

Available online at [www.sciencedirect.com](http://www.sciencedirect.com)**ScienceDirect**

Transportation Research Procedia 12 (2016) 239 – 251

---

---

**Transportation  
Research  
Procedia**

---

---

[www.elsevier.com/locate/procedia](http://www.elsevier.com/locate/procedia)

The 9th International Conference on City Logistics, Tenerife, Canary Islands (Spain), 17-19 June  
2015

## Interval travel times for more reliable routing in city logistics

Patrick-Oliver Groß <sup>a\*</sup>, Michael Geisinger <sup>a</sup>, Jan Fabian Ehmke <sup>b</sup>, Dirk Christian Mattfeld <sup>a</sup>

<sup>a</sup> Technische Universität Braunschweig, Decision Support Group, Mühlentorstraße 23, 38106 Braunschweig

<sup>b</sup> Freie Universität Berlin, Advanced Business Analytics Group, Garystraße 21, 14195 Berlin

---

### Abstract

Due to varying traffic volumes and limited traffic infrastructure in urban areas, travel times generally are uncertain and differ during the day. In this environment, city logistics service providers (CLSP) have to fulfill deliveries cost-efficiently and reliably. To ensure cost-efficient routing while satisfying promised delivery dates, information on expected travel times between customers needs to be exploited. If a sufficient amount of data is not available or expensive to acquire, deriving this information presents a major challenge for CLSP. Therefore, we propose the usage of interval travel times (ITT) to enable cost-efficient and reliable routing in urban areas. ITT define an expected range of travel times, which can be derived with relatively low effort by CLSP. We modify an existing approach from the domain of robust planning to the requirements of routing in urban areas. Further, we present and discuss the process of deriving ITT. An exemplary city logistics setting is developed and different routing solutions are examined. Computational experiments show that, in contrast to well-known deterministic approaches, routing considering ITT allows both cost-efficient and reliable routing.

© 2016 The Authors. Published by Elsevier B.V. This is an open access article under the CC BY-NC-ND license (<http://creativecommons.org/licenses/by-nc-nd/4.0/>).

Peer-review under responsibility of the organising committee of the 9th International Conference on City Logistics

**Keywords:** reliability, interval travel times, robust, routing;

---

---

\* Corresponding author. Tel.: +49 531-391-3216 ; fax: +49 531-391-8144.  
E-mail address: [p.gross@tu-braunschweig.de](mailto:p.gross@tu-braunschweig.de)

## 1. Introduction

Urban transportation mainly deals with last-mile deliveries. Last-mile deliveries are one of the most important parts of the supply chain, but also represent a very expensive and inefficient part of the entire supply chain (Gevaers, Van de Voorde and Vanelander, 2011). The need for making last-mile delivery operations more efficient and environmentally acceptable has led to the concept of city logistics (Crainic, 2008; Taniguchi et al., 2001). City logistics concepts focus on integrated solutions that allow for efficient and reliable urban transportation while reducing negative impacts. In this course, city logistics service providers (CLSP) face two major challenges.

On the one hand, e-commerce and online retailing has been growing continuously (ATKearny, 2013). Today's e-commerce business models require cost-efficient as well as customer-oriented last-mile deliveries in order to stay competitive (Agatz et al., 2011). This becomes especially challenging when customers are promised on-time delivery, e.g., in attended home delivery applications (Ehmke and Campbell, 2014). On the other hand, advancing urbanization causes increased traffic demand along the limited infrastructure of urban traffic systems. As a result, travel times vary heavily throughout the day, which counteracts the efficient and reliable planning of delivery tours.

City logistics concepts can correspond to these challenges by applying different optimization approaches and by integrating different levels of travel time information. Optimization approaches require information on the expected travel times of the urban traffic network to provide delivery tours with reasonable quality (Ehmke, Steinert and Mattfeld, 2012). The estimation of realistic travel times for the considered traffic network has a major impact on the quality of routing. Therefore, travel time models representing single travel time values per link, e.g., road distance and their corresponding speed limit, are not a sufficient input for reliable routing in urban areas (Eglese, Maden and Slater, 2006). To ensure cost-efficient routing while satisfying promised delivery dates, information on the expected range of travel times between customers needs to be exploited.

In this paper, the usage of interval travel times (ITT) is proposed to enable cost-efficient and reliable routing in urban areas. ITT define a best-case and a worst-case travel time. They can be derived with relatively low efforts by CLSP. The use of ITT allows for applying methods from the area of robust planning. To the best of our knowledge, ITT have not been studied within the scope of routing in city logistics. Thus, in this paper, we present and discuss the process of deriving ITT. Further, we extend an approach from the domain of robust planning and modify it to the requirements of routing in urban areas. In particular, we modify the approach of Montemanni et al. (2007) for city logistics and additionally consider customer time windows. We present a mathematical model and compare the results of routing with ITT to deterministic routing, especially with regard to efficiency and reliability of delivery tours.

The remainder of the paper is organized as follows: (1) A literature review on city logistics routing models, the role of travel time information and technology to determine travel times is given. (2) The concept of robust optimization is introduced by means of the Robust Traveling Salesman Problem and additionally extended by time windows. (3) A case study for robust routing in city logistics is presented. This includes the derivation of ITT and the evaluation of the robust routing approaches in the context of city logistics. (4) A conclusion is given and future work steps are illustrated.

## 2. Related Literature

In our literature review, we discuss related approaches to routing in city logistics. In particular, models and methods that incorporate different types of travel time information are considered. How travel times are modeled has a significant impact on the efficiency and reliability of routing. Thus, we finally discuss different approaches to model and consider travel times.

### 2.1. Routing in City Logistics

When dealing with optimization models to compute cost-efficient delivery tours, two basic modeling approaches are well known. Focusing on the order of customers within a delivery tour, the basic modeling approach is represented by the Traveling Salesman Problem (TSP). Lawler et al. (1985) and Laporte (1992) give an overview of the TSP. When additionally considering the assignment of customers to several vehicles, the basic modeling approach is the Vehicle Routing Problem (VRP). For a recent overview of the VRP see Laporte (2009). Both problems belong to the

class of NP-hard optimization problems. Therefore, these problems are commonly solved with heuristic methods that obtain good solutions in reasonable computation time.

In city logistics, travel times are of particular importance, as they have a major impact on the results of routing. Therefore, solution approaches that focus on the incorporation of travel times are relevant in this context. Fleischmann, Gietz and Gnutzmann (2004) and Van Woensel et al. (2008) consider deterministic time-dependent travel times and solve the corresponding Time-Dependent Vehicle Routing Problem (TDVRP). Their results show that the incorporation of time-dependent travel times leads to improved routing results. Ehmke (2012) and Cattaruzza et al. (2015) give an overview on solution methods for the TDVRP in the context of city logistics.

Stochastic routing approaches provide the opportunity to incorporate reliability aspects in city logistics routing. Laporte, Louveaux and Mercure (1992) were the first to consider stochastic travel times as a part of the VRP. They present a chance-constrained model that limits the probability that the duration of a delivery tour exceeds a given limit. The problem is solved with a branch-and-cut algorithm for instances up to 20 vehicles while travel times can take on a value from five discrete states. Lecluyse, Van Woensel and Peremans (2009) extend the VRP by incorporating the standard deviation of the travel time into the objective function. Travel times are assumed to follow a lognormal distribution. The problem is solved with an adapted tabu search. Computational experiments show that a larger weighting of travel time variance leads to longer, but more reliable routes.

Robust routing approaches allow to determine solutions that consider both efficiency aspects as well as reliability aspects. Many approaches from the domain of robust optimization deal with shortest path or network flow problems (Zielinski, 2004; Montemanni and Gambardella, 2004; Averbakh and Lebedev, 2004; Bertsimas and Sim, 2003). To the best of our knowledge, Montemanni et al. (2007) were the first to incorporate travel times represented by intervals in the context of routing. They solve the Robust Traveling Salesman Problem with interval data (RTSP) by applying different exact solution approaches such as Benders decomposition. Additionally, basic heuristics are proposed. Cho, Burer and Campbell (2010) also solve a TSP with ITT. They incorporate a parameter that allows controlling the conservatism towards expected travel times. Both routing approaches are mathematically motivated and do not aim at practical implications on city logistics.

## 2.2. Travel Time Information Models

Travel times have a significant impact on the performance of planned tours under real world conditions (Ehmke, Meisel and Mattfeld, 2012). Therefore, the efficiency and reliability of routing in city logistics is influenced by the considered amount and detail of travel time information. Recent advances in telematics technologies offer the opportunity to derive different types of travel time information empirically from real-world data, e.g., floating car data (Brockfeld et al., 2007). By facilitating different information models of travel time information, different levels of reliability in routing can be accomplished.

*Deterministic Travel Time Information.* The most common way to consider travel times in routing are deterministic mean travel times. Mean travel times are a rough estimation of expected travel times and therefore deliver little information on the evolution and variation of real-world travel times (Eglese, Maden and Slater, 2006). In recent years, time-dependent travel times have attracted increasing interest. Time-dependent travel times represent the expected evolution of travel times by a given number of mean or median travel time values (e.g., 7x24 travel time aggregates for a link, (Ehmke, 2012). Through this, a more accurate estimation of travel times is possible, leading to more realistic estimates of expected travel times. Deterministic models may be sufficient when reliability is not a major concern. However, as they do not explicitly provide any kind of information on the uncertainty of travel times, they are not suitable as input for more reliable routing.

*Stochastic Travel Time Information.* In contrast to deterministic travel time models, stochastic travel time models provide a continuous representation of travel times and their variation. Stochastic travel times are represented by distributions, which can provide required information such as the variation of travel times. Distributions such as the normal distribution may be mathematically convenient, but they may not truly represent urban travel times. More complex distributions such as the Burr III Type XII distribution may better reflect the nature of urban travel times (Susilawati, Taylor and Somenahalli, 2013), but processing them for routing applications, e.g., by combining them on

a link-to-link level is often difficult if a closed form is not available for the required mathematical operations (Ehmke, Campbell and Urban, 2015). Finally, it is still controversial if any appropriate distribution for urban travel times exists that truly represents the nature of urban travel times and that is manageable for practical applications.

*Interval Travel Times.* Representing travel times in terms of intervals allows for considering the effects of uncertainty without requiring additional or very detailed information about the underlying travel time behavior. Most importantly, no assumptions on the probability distribution are required (Karasan, Pinar and Yaman, 2001). First, ITT allow for the explicit consideration of uncertainty by means of the main range of possible travel times. Second, if data is sparse, e.g., only some travel time observations are given, reasonable results concerning the representation of travel times can still be achieved. In such a case, an empirically fitted distribution would probably yield poor results. The approximation of a distribution requires a certain amount of data to achieve a good fitting (Ehmke, Campbell and Urban, 2015). Often, CLSP are not able to gather enough data with their own fleet. Buying required data from commercial providers, e.g., TomTom (2015), may be expensive. Third, for routing in city logistics, travel time information on a customer-to-customer level is required. When determining travel times from real-world data, this data is provided on a detailed road network link level. Thus, link-level based information has to be combined to a customer-to-customer edge level. Ehmke (2012) presents such a data driven optimization process for deterministic, time-dependent travel times. Employing interval arithmetic, such a data driven approach could be realized with low effort when using ITT. Considering distributions of travel times, this task becomes much more complex, as the combination of distributions is not a trivial task.

### 3. Robust Routing in City Logistics

In this section, we introduce a recent optimization approach on interval based routing. First, we describe the problem and the solution approach in detail and discuss relevant aspects of robust routing. Second, we present how we extend the approach to city logistics.

#### 3.1. Interval Based Routing

The basic graph can be described as follows. Let  $G = (V, E)$  be a complete, undirected graph where  $V$  is a vertex set of locations  $\{v_0, \dots, v_n\}$ . Vertex  $v_0$  represents the depot while the vertices  $v_1, \dots, v_n$  represent the customers to be visited by means of a delivery tour.  $E$  is the set of edges  $\{(i, j) \mid i, j \in V, i \neq j\}$  connecting the customers. Each edge  $e_{i,j}$  is associated with an interval  $[l_{ij}, u_{ij}]$  where  $l_{ij} \leq u_{ij}$  applies. The parameter  $l_{ij}$  describes the expected best cost and the parameter  $u_{ij}$  represents the expected worst cost for traversal of the corresponding edge. A scenario  $r \in S$  represents the realization of edge costs. For every edge belonging to a scenario  $r$ , a cost value is chosen by means of  $c_{ij}^r \in [l_{ij}, u_{ij}]$ . The objective is to find a delivery tour that realizes the minimum cost, according to a criterion that determines a reliable routing solution. We choose the *minmax regret criterion* from the domain of robust optimization. This allows us to incorporate both efficiency and reliability measures in route planning. This corresponds to the RTSP as described by Montemanni et al. (2007).

*Minmax regret criterion.* The minmax regret criterion determines the decision alternative that minimizes the potential negative outcome over all possible (real-world) realizations. From the perspective of city logistics routing, a decision alternative can be seen as a set of routing decisions (tour), and the possible realization can be understood as a scenario of realized costs. For a better understanding of the minmax regret criterion, let us exemplify its effect as follows:

A scenario  $r \in S$  is defined as a possible combination of  $c_{ij}^r \in [l_{ij}, u_{ij}] \forall e \in E$ . We consider a particular scenario, e.g., scenario  $r = 1$ . Fig. 1 illustrates a small number of scenarios on an undirected graph. First, we have to determine all possible tours within this scenario (see Step 1, Fig. 1). Then, we solve the TSP for this particular scenario in order to find the cost-optimal tour. Then, the cost of any other tour is subtracted from the cost of the cost-optimal tour (see Step 2, Fig. 1). This yields the regret or robust deviation for a particular tour in this scenario. The robust deviation quantifies the possible cost gap between the current tour and the cost-optimal tour in the scenario. This gap increases if we choose a tour that differs more from its optimal counterpart than an alternative tour. Finally, we choose the tour

in the considered scenario that yields the maximum regret (see Step 3, Fig. 1). In essence, we have calculated the maximum robust deviation for one particular scenario now. This procedure is repeated for all scenarios in  $S$ . Then, we can choose the tour that yields the smallest maximum robust deviation (see Step 4, Fig. 1), which we indicate as the *optimal robust deviation* for the remainder of the paper. The idea is that the found tour should perform considerably well under any possible scenario, as the deviation between the cost of the tour and the cost of its best-case counterpart has been minimized over all possible realizations of edge costs. One can easily recognize that applying the minmax regret criterion to a routing problem with interval data leads to high computational complexity, as every possible scenario of cost realizations has to be considered.

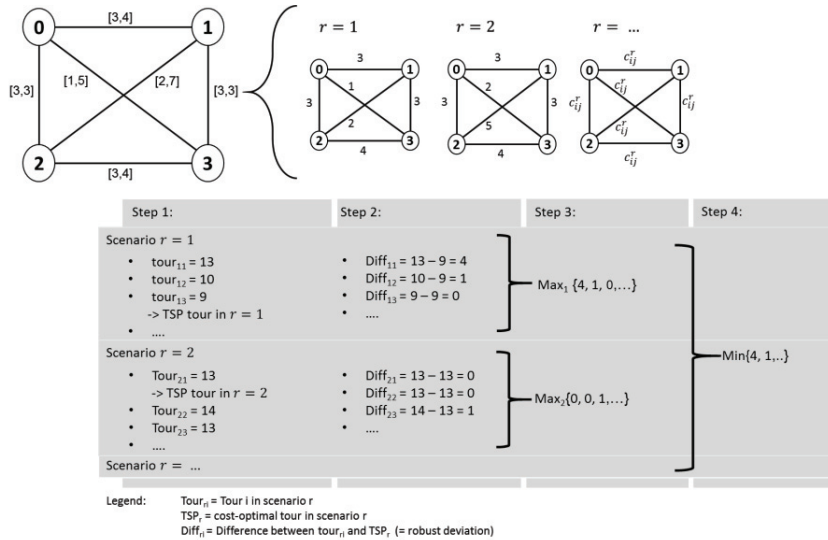

Fig. 1. Exemplary Computation of Robust Deviation

To reduce the complexity induced by the large number of scenarios, Montemanni et al. (2007) prove that it is sufficient to consider only a subset of scenarios. The size of the subset is equal to the number of possible tours in the graph. This reduced number of scenarios is represented by the set  $R$ . To form such a scenario  $r \in R$ , an arbitrary tour in the graph  $G$  is chosen. In the remainder of the paper, this tour is called the “candidate tour”  $cand^r$ . According to the edges used by the candidate tour, the costs of all edges in the particular scenario are determined as follows: All edges  $e \in cand^r$  are weighted with their maximum cost value ( $c_{ij} = u_{ij}$ ), and all edges  $e \notin cand^r$  are weighted with their minimum cost value ( $c_{ij} = l_{ij}$ ). Due to the basic principle of the minmax regret criterion, it is sufficient to only consider the reduced number of scenarios as the maximum robust deviation can only be achieved by choosing the maximum cost values. Choosing values lower than the maximum cost for the candidate tour would not maximize the robust deviation.

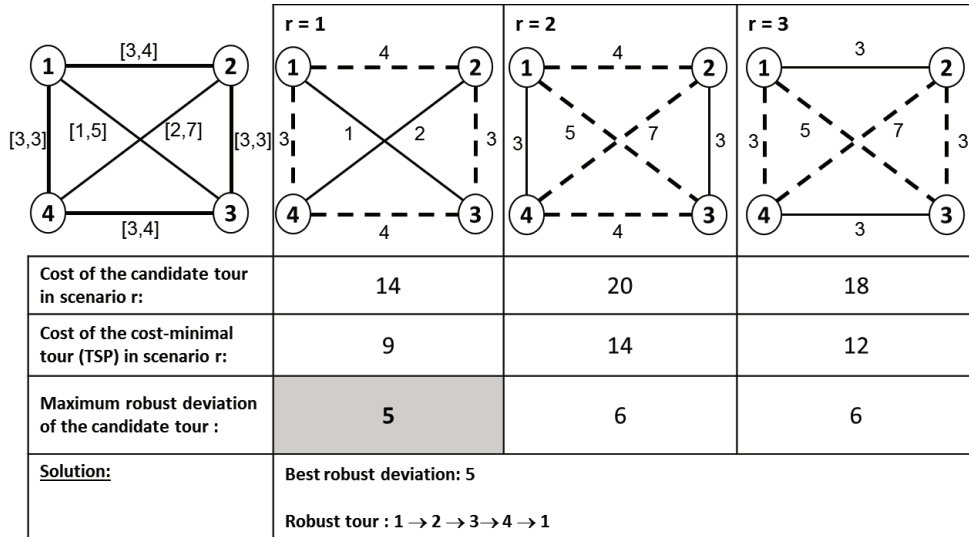

Fig. 2. Scenario Generation

Fig. 2 illustrates the forming of scenarios according to the described approach and the corresponding identification of the tour with the best robust deviation. The dashed lines correspond to the respective candidate tour of the scenario. The three scenario graphs show that the edges of the candidate tour realize the maximum travel time. For Scenario 1, the costs of the candidate tour are 14. Additionally, a TSP has to be solved to determine the cost-minimal tour  $short^r$  (and its cost) within this scenario. While the edges used in the candidate tour are fixed, the solution of the TSP can use both the dashed edges as well as the regular edges. For Scenario 1, the cost-minimal tour has total costs of 9. Now the robust deviation can be determined by calculating the difference between the cost of the candidate tour and the cost of the cost-optimal tour. For Scenario 1, we obtain a regret of  $14 - 9 = 5$ . Due to the chosen edge weights  $u_{ij}$  and  $l_{ij}$ , the robust deviation is also the maximum robust deviation for this scenario and no other tours have to be examined. After determining the regret for all scenarios, the candidate tour that realizes the smallest maximum regret is chosen as the robust tour. In this example, the candidate tour from Scenario 1 is the robust tour with a robust deviation of 5.

### 3.2. Interval Based Routing for City Logistics

We now consider the previously described RTSP model and extend it according to the requirements of routing in city logistics. Therefore, the graph from the previous section is extended as follows. The graph  $G = (V, E)$  is still a complete, but now *directed* graph. We interpret the cost of an edge as travel time  $tt_{ij}^r \in [l_{ij}, u_{ij}]$ . For each customer  $i$ , a soft customer time window  $[a_i, b_i]$  describes the time in which the customer should be served. The service at a customer should not start earlier than  $a_i$  and not later than  $b_i$ . If the customer time window is violated, waiting costs  $t_i^w \geq 1$  for being early and lateness costs  $t_i^m \geq 1$  for being late arise. The considered tours are assumed to satisfy all constraints of a standard TSP. The objective of the extended RTSP, the RTSP-TW, is to find the candidate tour  $cand^r$  that has the optimal robust deviation while considering customer time windows. The reduced objective function can be described as stated in equation (1).

$$best\ robust\ deviation = \min_R \{ TDCand^r - TDTSP^r \} \tag{1}$$

$TDCand^R$  represents the total duration of a candidate tour with soft time windows in scenario  $r$ , while  $TDTSP^R$  represents the total duration of the cost-optimal tour with soft time windows in scenario  $r$ . The difference of both tours total durations yields the robust deviation with time windows for the scenario  $r \in R$ , where  $R$  is the set of reduced

number of scenarios. By iterating over all scenarios  $S$ , the candidate tour is chosen that minimizes the robust deviation. The detailed calculation of the total duration is explained in the following.

$$TDcand^r = \underbrace{\sum_{(i,j) \in E} u_{ij} * x_{ij}}_{\text{total travel time}} + \underbrace{\sum_{i \in N, v_{n+1}} t_i^w * w_i^{cand}}_{\text{total waiting time}} + \underbrace{\sum_{i \in N, v_{n+1}} t_i^m * m_i^{cand}}_{\text{total lateness}} \quad (2)$$

The total duration of the candidate tour  $cand^r$  is calculated as stated in equation (2). It consists of the sum of all travel times between customers, the sum of occurred waiting times  $w_i^{cand}$  multiplied by a penalty factor  $t_i^w$ , and lateness  $m_i^{cand}$  multiplied by a penalty factor  $t_i^m$ . All travel times of the tour  $cand^r$  are weighted with their maximum travel time  $u_{ij}$ . The binary decision variable  $x_{ij} = \{0,1\}$  determines if an edge is part of the candidate tour or not.

$$TDTSP^r = \min \left\{ \underbrace{\sum_{(i,j) \in E} (l_{ij} + \overbrace{(u_{ij} - l_{ij}) * x_{ij}}^{\text{candidate tour edge used}}) * y_{ij}}_{\text{total travel time}} + \underbrace{\sum_{i \in N, v_{n+1}} c_i^w * w_i^{TSP}}_{\text{total waiting time}} + \underbrace{\sum_{i \in N, v_{n+1}} c_i^m * m_i^{TSP}}_{\text{total lateness}} \right\} \quad (3)$$

The total duration of the cost-optimal tour in scenario  $r$  is determined by a special TSP formulation as stated in equation (3). Total waiting time and total lateness are calculated analogously to the candidate tour. In contrast to the candidate tour, the cost-optimal tour can include edges that are weighted with  $u_{ij}$  or edges that are weighted with  $l_{ij}$ . This has to be considered in the calculation of the total travel time. Therefore, an additional binary decision variable  $y_{ij}$  is introduced. If an edge is part of the cost-optimal tour,  $y_{ij}$  is set to 1. If the particular edge is also part of the candidate tour,  $x_{ij}$  is set to 1. This adds the term described as “candidate tour edge used” to the regular travel time  $l_{ij}$ . Due to this, the travel time becomes equal to  $u_{ij}$ . If the edge is not part of the candidate tour,  $x_{ij}$  becomes 0 and hence the term “candidate tour edge used” becomes 0 resulting in a travel time of  $l_{ij}$ .

The extended objective function can be derived by applying equations (2) and (3) to equation (1). The impact of customer time windows on robust routing is exemplified in the following experiment.

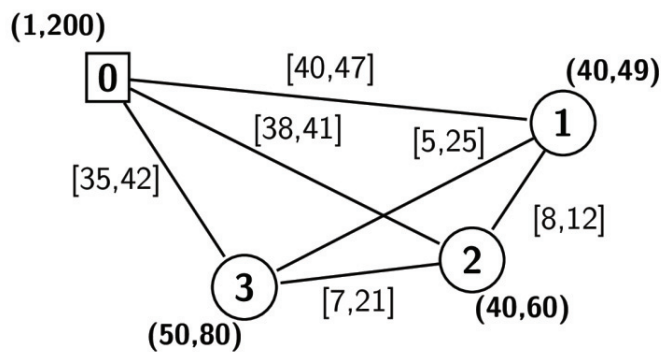

Fig. 3. Example Network for Routing with Time Windows

Table 1. Results from Standard TSP with Time Windows

tour	total travel time	total waiting time	total lateness	total duration
0-1-2-3-0	106	0	0	106
0-1-3-2-0	112	0	12.5	124.5
0-2-1-3-0	103	0.5	1	<b>104.5</b>
0-2-3-1-0	112	0.5	20	132.5
0-3-1-2-0	103	11.5	31	145.5
0-3-2-1-0	106	11.5	29	146.5

Table 2. Results from Robust Routing with Time Windows

#	candidate tour	RTSP			RTSP-TW								robust deviation
		candidate tour	cost optimal tour	robust deviation	candidate tour				cost optimal tour				
		cost	cost		total travel time	total waiting time	total lateness	total duration	total travel time	total waiting time	total lateness	total duration	
1	0-1-2-3-0	122	97	25	122	0	0	122	97	2	3	102	<b>20</b>
2	0-1-3-2-0	134	109	25	134	0	33	167	109	0	0	109	58
3	0-2-1-3-0	120	101	<b>19</b>	120	0	4	124	101	0	0	101	23
4	0-2-3-1-0	134	109	25	134	0	38	172	109	0	0	109	63
5	0-3-1-2-0	120	101	<b>19</b>	120	8	53	181	101	0	0	101	80
6	0-3-2-1-0	122	97	25	122	8	45	175	97	2	3	102	73

The experiment is conducted on a simple network with a depot (0) and three customers (1-3), illustrated in Fig. 3. ITT are represented by square brackets on the edges. Curved brackets indicate the time windows for each customer. Table 1 contains the calculations for a standard TSP with time windows and mean travel times. Table 2 contains calculations for the RTSP on the left side as well as for the RTSP-TW on the right side. Gray highlighting indicates the tour that is considered as optimal solution for the corresponding routing approach.

Comparing the standard TSP model and the RTSP-TW, it can be observed that different candidate tours are chosen as an optimal solution. In the standard TSP model, the candidate tours 3 or 5 are optimal. For the RTSP-TW, candidate tour 1 is considered as optimal. Comparing the results to a standard TSP with time windows shows that the candidate tour has no lateness or waiting time, while in the standard TSP waiting and lateness occur. Also, the tour chosen in the standard TSP with time windows includes the edge from customer 3 to customer 1 (see Fig. 3), which has the highest travel time variation in this example and should therefore be available.

How the different considerations of travel time variation affect the efficiency and reliability of routing is discussed in the following.

#### 4. City Logistics Case Study

In this chapter, we present a case study to exemplify the effects and potential benefits of robust routing with ITT in a more realistic city logistics setting. First, a fictitious, simplified network for routing in city logistics is presented. This includes a basic simulation approach to capture effects of uncertain travel times. Second, an approach to derive ITT from a data set of empirical travel times is described. Third, evaluation criteria for the comparison of deterministic routing and routing with ITT are described. These criteria are then evaluated by simulation.

##### 4.1. Example Network

In city logistics, customers are usually distributed over different areas of the city, e.g., several urban districts or downtown and suburb areas. Customers in one area are relatively close to each other while the distance between a group of customers can be relatively high, e.g., if customers are located in districts that are on opposite sides of the city. Connections near the city core usually feature low speed limits and the variation caused by varying traffic volumes



are assumed to not have a significant impact on the realized travel speed. Suburb connections are usually not working to capacity and feature relatively high travel speeds. As a result, these connections are less likely to realize significant variations in travel time. City areas or districts are interconnected by arterials. These urban arterial connections are heavily influenced by the traffic volume or uncertain events, e.g., accidents. Therefore, travel times on arterial roads vary significantly (Ehmke, 2012).

The example network, shown on the left side of Fig. 4, instantiates the described properties. The network is split into two regions, a suburb region outside the dashed line and an inner city region inside the dashed line. The network contains of 13 customer locations and one depot. Circles indicate customer locations while the depot is indicated by a square. Customers are divided into two different categories corresponding to the region they are located in: 1-5 are "suburb" customers, while 6-13 are "inner city" customers. Edges between customers correspond to their respective origin-destination customer categories.

Travel times between customers are derived by their Euclidean distance and a given speed value, which reflects different categories of travel speeds attached to the edge types (see right side of Fig. 4). Edges represent customer-to-customer paths that inherit link level correlation.

Following the above explanation, we assume that travel times do not vary for edges of inner city and suburb connections. Thus, these travel times are constants without any travel time variation. Edges that are arterial connections are affected by significant variations in travel times. For these edges, we assume the travel times to follow a shifted gamma distribution which is an established approximation of urban travel times (Ehmke, Campbell and Urban, 2015). This allows to explicitly control the variance of travel times and examine the resulting effects on routing in computational experiments.

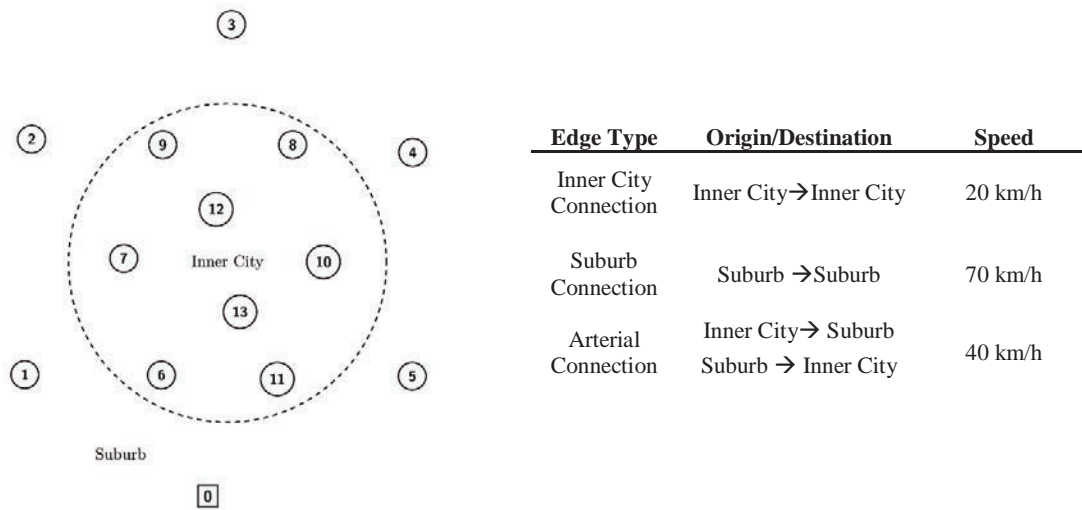

Fig. 4. Example Network and Edges between Customers

#### 4.2. Computation of Interval Travel Times

We derive an example data set of travel times for the above network by generating travel time observations from the shifted gamma distribution for each edge. An example for a set of resulting samples and ITT is illustrated in Fig. 5. The corresponding minimum and maximum travel times, or lower and upper bound of the interval, are determined by the 5% and 95% quantile. Those are shown in Fig. 5 as the upper and lower borders of the boxes. Focusing on the quantiles, we can exclude extreme cases of travel times which do not represent the typical bandwidth of travel times for a given link or edge. In a real-world setting, we would observe the travel times from delivery operations based on

GPS technology and set the quantiles according to the preferences of the route planner or we would use different quartiles for different types of edges.

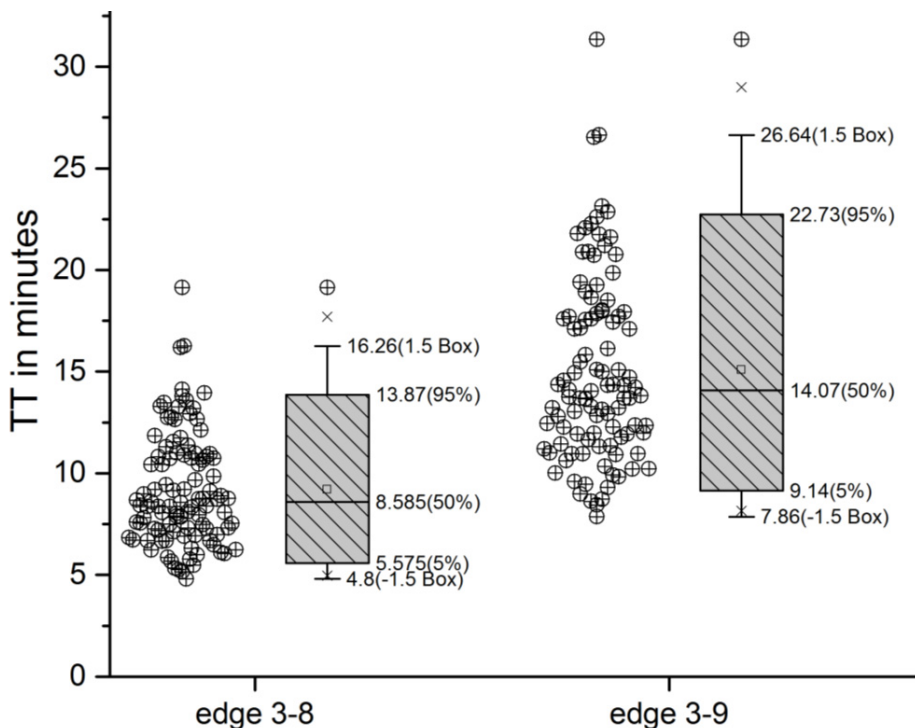

Fig. 5. Sample of Travel Times and Boxplots for 5% and 95% Quartile for Two Different Edges

#### 4.3. Evaluation of Robust Routing

To illustrate the general effects and benefits of routing with ITT, we implemented the RTSP model as well as a standard TSP model using JAVA and the commercial solver IBM ILOG CPLEX 12.5.1. Note that for these illustrations, we do not consider customer time windows, as it is our primary goal to highlight the potential of ITT compared to a TSP tour. Future work will assess the impact of customer time windows in a VRP setting.

The experiment consists of two phases. Within the first phase, the planning phase, tours are optimized. Three types of travel time information are considered. First, a mean travel time based tour is determined by calculating the mean travel times for each edge from the sample speed values. Then, a standard TSP is solved based on these travel times. Second, a worst case tour is determined by calculating a standard TSP incorporating the upper bound values of the intervals for each edge. Third, the RTSP tour is calculated considering ITT. To this end, we employ the construction heuristic “HMU” as described by Montemanni et al. (2007). Choosing different sample sizes did not impact the routing results significantly. Only extreme cases of very small sample size, e.g. 10 samples, had a significant impact but led to rather unrealistic results. Therefore, we choose to use a fixed amount of 500 travel time samples per edge.

Within the second phase, the evaluation phase, tours from the planning phase are evaluated. One realization of the network is produced by sampling each edge travel time once. Thus, one evaluation run represents a concrete realization of travel times. As only the edges between outer and inner city show significant variation of travel times, these can change with every run according to the shifted gamma distribution. Every tour is evaluated 100 times on different travel time realizations. The results are then compared over all runs.

Based on the results of the simulation, we first discuss the general routing implications in terms of customer order and the corresponding travel time model. Second, we consider the tour duration and the simulated lateness as criteria for the efficiency and reliability of the routing with different travel time models.

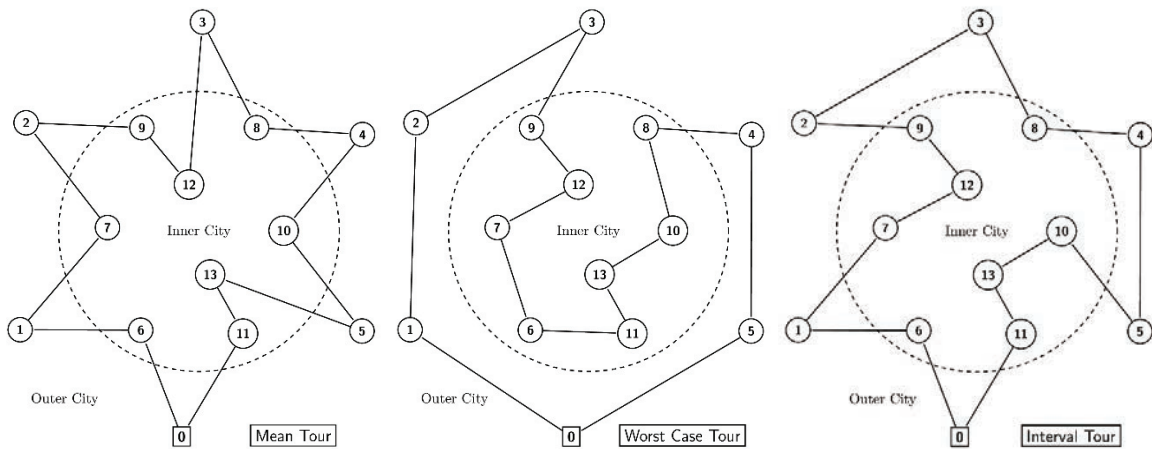

Fig. 6. Results for Different Travel Time Information Models

Fig. 6 illustrates the results of routing when considering different travel time information and the corresponding optimization approaches. The left graph shows the result of routing with mean travel times (standard TSP). Here, the variation of travel times is ignored, and multiple entering and leaving of the inner city area can be observed. This represents the favoring of a lower tour duration while not taking possible travel time variation on edges between inner and outer city areas into account. In contrast to that, the middle graph shows the result of optimizing the standard TSP with worst case travel times. Here, the result suggests to go around the inner city, enter the inner city once, visit all customers inside and then leave the inner city again to finish the rest of the tour. Finally, the right graph shows the routing with ITT. This solution can be seen as a middle ground between the other two results. Here, the border between inner city and outer city is not traversed as often as for the example of mean travel times, reducing the risk of edges connecting the two areas, but more often than for the worst case tour.

Table 3. Results for Different Variances of Travel Times

TT Variance	Tour	Total TT	Total TT Diff	Service Level	Service Level Gain
10%	Mean Value	133.82	/	72%	/
	Worst Case	135.23	1.05%	74%	4.78%
	Interval	134.27	0.33%	73%	2.98%
20%	Mean Value	132.81	/	67%	/
	Worst Case	152.71	14.98%	92%	1.92%
	Interval	134.56	1.31%	72%	3.84%
30%	Mean Value	133.20	/	62%	/
	Worst Case	153.40	15.16%	87%	1.90%
	Interval	134.53	0.99%	66%	4.06%

Table 3 illustrates the effects of using the different optimization approaches in the environment of different levels of travel time variation (10%, 20%, 30% of the mean). “Total TT” captures the average total travel time for each routing approach. “Total TT Difference” indicates the difference in average total travel time in comparison to the mean value tour. We determine the “service level gain” per percent tour duration. This is calculated based on the mean value tour and yields the trade-off between the duration of a tour and the possible service level gain.

With a travel time variance of 10%, the resulting tours are relatively similar in duration, lateness and service level gain. Due to the low variance, the mean value is a good approximation, and uncertainty seems to not have a big impact on the results of routing. With a travel time variance of 20%, differentiated result can be observed. In terms of the average travel time, the ITT based tour is 1.31% longer, but relatively close to the mean value tour, while the worst case tour is significantly longer. In terms of lateness, the worst case tour achieves the best service level, but at the cost of much longer average tour duration. The service level gain is higher with the interval tour. This trend continues with increased travel time variance. In sum, with increasing variance of travel times, the interval tour achieves a better trade-off between average tour duration and lateness than the worst case tour, esp. when the duration of a tour and lateness are considered as equally important.

## 5. Conclusion

The need for cost-efficient as well as reliable deliveries results in major challenges for CLSP due to heavily varying travel times in the urban traffic network. In this paper, we discussed different travel time models and their properties regarding the consideration of travel time uncertainty. We identified ITT as a suitable travel time model to support a data driven optimization approach. ITT were incorporated into a robust routing approach that considers the efficiency as well as the reliability of tours. We exemplified that considering time windows in the robust routing approach leads to different and more reliable routing in contrast to a deterministic approach. Further, a case study depicted the influence of travel time variation on city logistics routing. It could be shown that the incorporation of ITT leads to improved routing in terms of efficiency and reliability of tours.

A drawback of the presented approach manifests in the equal consideration of cost and reliability in terms of tour duration and travel time variation. As stated in Cho, Burer and Campbell (2010), for example, there is no possibility to adapt the “level of pessimism” in the model and to define the relative importance of reliability compared to efficiency. In further research, an adaption to control this factor could allow us to obtain solutions that are more reliable but also capture a suitable amount of efficiency in terms of tour duration.

Further research will deal with the parametrization of the RTSP and the RTSP-TW model to weight cost and reliability in a more sophisticated way and the implementation of time windows in a VRP setting. Additionally, an enhanced underlying test network will be developed to offer more possibilities in route choices and incorporate more realistic travel time variations. Further, improved heuristic methods will allow to identify higher quality solutions in reasonable time.

## References

- Agatz, N., Campbell, A., Fleischmann, M. and Savelsbergh, M. (2011). Time slot management in attended home delivery, *Transportation Science*. INFORMS, 45(3), 435–449.
- ATKearny (2013). Online Retail Is Front and Center in the Quest for Growth.
- Averbakh, I. and Lebedev, V. (2004). Interval data minmax regret network optimization problems, *Discrete Applied Mathematics*. Elsevier, 138(3), 289–301.
- Bertsimas, D. and Sim, M. (2003). Robust discrete optimization and network flows, *Mathematical Programming*. Springer, 98(1-3), 49–71.
- Brockfeld, E., Lorkowski, S., Mieth, P. and Wagner, P. (2007). Benefits and limits of recent floating car data technology-an evaluation study, in 11th WCTR Conference.
- Cattaruzza, D., Absi, N., Feillet, D. and González-Feliu, J. (2015). Vehicle routing problems for city logistics, *EURO Journal on Transportation and Logistics*. Springer, 1–29.
- Cho, N., Burer, S. and Campbell, A. M. (2010). Modifying Soyster’s model for the symmetric traveling salesman problem with interval travel times.
- Crainic, T. G. (2008). City Logistics, *Tutorials in Operations Research: State-of-the-Art Decision-Making Tools in the Information-Intensive Age*, 181–212.
- Eglese, R., Maden, W. and Slater, A. (2006). A Road TimetableTM to aid vehicle routing and scheduling, *Computers & Operations Research*. Elsevier, 33(12), 3508–3519.
- Ehmke, J. F. (2012). Integration of information and optimization models for routing in city logistics. Springer.
- Ehmke, J. F. and Campbell, A. M. (2014). Customer acceptance mechanisms for home deliveries in metropolitan areas, *European Journal of Operational Research*, 233(1), 193–207.
- Ehmke, J. F., Campbell, A. M. and Urban, T. L. (2015). Ensuring service levels in routing problems with time windows and stochastic travel times, *European Journal of Operational Research*. Elsevier, 240(2), 539–550.

- Ehmke, J. F., Meisel, S. and Mattfeld, D. C. (2012). Floating car based travel times for city logistics, *Transportation Research Part C: Emerging Technologies*. Elsevier, 21(1), 338–352.
- Ehmke, J. F., Steinert, A. and Mattfeld, D. C. (2012). Advanced routing for city logistics service providers based on time-dependent travel times, *Journal of Computational Science*. Elsevier, 3(4), 193–205.
- Fleischmann, B., Gietz, M. and Gnutzmann, S. (2004). Time-varying travel times in vehicle routing, *Transportation Science*. INFORMS, 38(2), 160–173.
- Gevaers, R., Van de Voorde, E. and Vanelslander, T. (2011). Characteristics and typology of last-mile logistics from an innovation perspective in an urban context, *City Distribution and Urban Freight Transport: Multiple Perspectives*, Edward Elgar Publishing, 56–71.
- Karasan, O., Pinar, M. and Yaman, H. (2001). The robust shortest path problem with interval data. 2001.
- Laporte, G. (2009). Fifty Years of Vehicle Routing, *Transportation Science*. INFORMS, 43(4), 408–416.
- Laporte, G. (1992). The traveling salesman problem: An overview of exact and approximate algorithms, *European Journal of Operational Research*. Elsevier, 59(2), 231–247.
- Laporte, G., Louveaux, F. and Mercure, H. (1992). The Vehicle Routing Problem with Stochastic Travel Times, *Transportation Science*. INFORMS, 26(3), 161–170.
- Lawler, E. L., Lenstra, J. K., Kan, A. R. and Shmoys, D. B. (1985). *The traveling salesman problem: a guided tour of combinatorial optimization*. Wiley New York.
- Lecluyse, C., Van Woensel, T. and Peremans, H. (2009). Vehicle routing with stochastic time-dependent travel times, *4OR*. Springer, 7(4), 363–377.
- Montemanni, R., Barta, J., Mastrolilli, M. and Gambardella, L. M. (2007). The robust traveling salesman problem with interval data, *Transportation Science*. INFORMS, 41(3), 366–381.
- Montemanni, R. and Gambardella, L. M. (2004). An exact algorithm for the robust shortest path problem with interval data, *Computers & Operations Research*. Elsevier, 31(10), 1667–1680.
- Susilawati, S., Taylor, M. A. and Somenahalli, S. V. (2013). Distributions of travel time variability on urban roads, *Journal of Advanced Transportation*. Wiley Online Library, 47(8), 720–736.
- Taniguchi, E., Thompson, R. G., Yamada, T. and Van Duin, R. (2001). *City Logistics. Network modelling and intelligent transport systems*.
- TomTom (2015). Real Time and Historical Traffic. <http://marketing.entgov.tomtom.com/acton/attachment/4701/f-0015/1/-/-/-/file.pdf> (Accessed: March 14, 2015).
- Van Woensel, T., Kerbache, L., Peremans, H. and Vandaele, N. (2008). Vehicle routing with dynamic travel times: A queueing approach, *European Journal of Operational Research*. Elsevier, 186(3), 990–1007.
- Zielinski, P. (2004). The computational complexity of the relative robust shortest path problem with interval data, *European Journal of Operational Research*. Elsevier, 158(3), 570–576.