

Available online at www.sciencedirect.com**ScienceDirect**

Energy Procedia 63 (2014) 2031 – 2036

Energy
Procedia

GHGT-12

Energy and cost evaluation of a low-temperature CO₂ capture unit for IGCC plants

David Berstad^{a,*}, Simon Roussanaly^a, Geir Skaugen^a, Rahul Anantharaman^a,
Petter Neksa^a, Kristin Jordal^a

^aSINTEF Energy Research, P.O. Box 4761 Sluppen, NO-7465 Trondheim, Norway

Abstract

The application of CO₂ capture by liquefaction has been investigated for an integrated gasification combined cycle (IGCC). Two configurations of the process are developed – one supplying CO₂ at conditions suitable for pipeline transport and the second one producing liquid CO₂ suitable for ship transport. The liquefaction process for CO₂ capture is more efficient and compact compared to Selexol process for providing CO₂ suitable for ship transport as the separation and liquefaction units are integrated in the process presented in this work. An economic analysis performed shows that CO₂ capture by liquefaction is more cost efficient than corresponding Selexol-based separation processes by 9–11% in terms of the levelized cost of electricity and 35–37% in terms of CO₂ avoidance costs.

© 2014 The Authors. Published by Elsevier Ltd. This is an open access article under the CC BY-NC-ND license (<http://creativecommons.org/licenses/by-nc-nd/3.0/>).

Peer-review under responsibility of the Organizing Committee of GHGT-12

Keywords: Pre-combustion; CCS; CO₂; Capture; IGCC; Energy; Cost; Liquefaction

1. Introduction

The major point sources of greenhouse gas emissions vary substantially in capture conditions for CO₂ [1]. Sources with high CO₂ concentration and/or CO₂ partial pressure are generally more attractive for CO₂ capture than those with more diluted CO₂. Integrated gasification combined cycles (IGCC) have rather high CO₂ concentration and partial pressure, in some cases as high as 20–30 bar, and such high CO₂ pressure can be utilised to achieve highly energy- and cost-efficient CO₂ separation and capture.

In the present work, a high-efficiency CO₂ capture unit for IGCC power plants based on CO₂ liquefaction is presented. The capture method is based on low-temperature phase separation (liquefaction), where condensed liquid

* Corresponding author. Tel.: +47-930-02-784; fax: +47-735-93-950.
E-mail address: david.berstad@sintef.no

CO₂ is separated from the uncondensed hydrogen-rich vapour phase. The shifted syngas under consideration consists of mainly hydrogen and CO₂, with a concentration of the latter close to 40%.

At GHGT-11, an energy benchmarking was presented [2] for the CO₂ capture by condensation, against Selexol as baseline technology. At 85% CO₂ capture ratio (CCR), the net electric efficiency of the IGCC plant was calculated to be 0.8–1.0 %-point higher using CO₂ condensation relative to the baseline cases with Selexol.

As a follow-up to the GHGT-11 paper [2] this work elaborates on a further techno-economic benchmarking, including the comparison of cost data. Moreover, energy and cost calculations also include a modified version of the CO₂ condensation process producing cold, liquid CO₂ for ship transport.

2. Methodology

2.1. CO₂ separation concept

Different process designs are possible for the low-temperature CO₂ capture and condensation unit. The proposed baseline process flow diagram for producing high-pressure CO₂ for pipeline transport is shown in Fig. 1. Cleaned and shifted syngas from a coal gasifier is first dehydrated and compressed to specified separation pressure and subsequently cooled to the specified separation temperature in a heat exchanger network consisting of process-to-process heat exchangers as well as utility heat exchangers. From the main separator, the liquid CO₂ product is further purified in a secondary flash separator, pumped and heated to transport state. The hydrogen-rich fuel product is heated and expanded sequentially until the gas turbine combustor feed state is reached. The process is not autothermal and requires auxiliary refrigeration, which can be provided by standard vapour-compression cascade refrigeration units. In this work propane (C3) and ethane (C2) are used as refrigerants although more sophisticated and efficient cycle designs are possible.

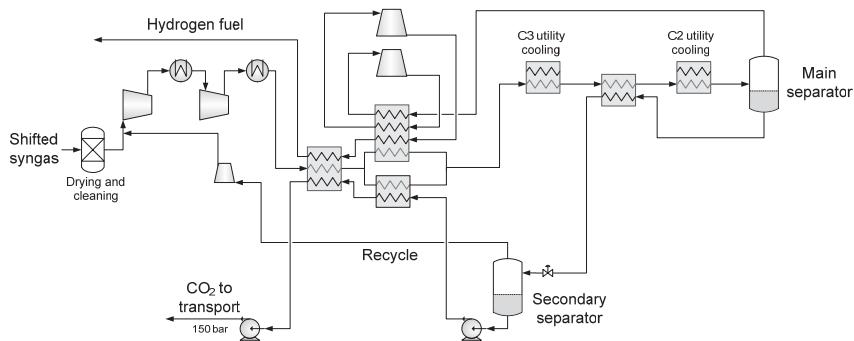

Fig. 1. Process flow diagram for the case of high-pressure pipe CO₂.

In addition to producing high-pressure CO₂ for pipeline transport, the process scheme can be modified to producing liquid CO₂ for ship transport by extracting the liquid product directly from the secondary flash separation unit. The process flow diagram for this option is shown in Fig. 2. In an early phase of CCS deployment where seaborne bulk transport of liquid CO₂ from source to sink may be required in the case of absent pipeline infrastructure, the low-temperature capture unit producing liquid CO₂ can provide a flexible solution, including a real option for a smooth future modification of the capture unit enabling production of high-pressure CO₂ for pipeline transport. The process scheme in Fig. 2 can in principle be retrofitted to the Fig. 1 scheme by adding the CO₂ pumps and reconfiguring a few heat exchangers.

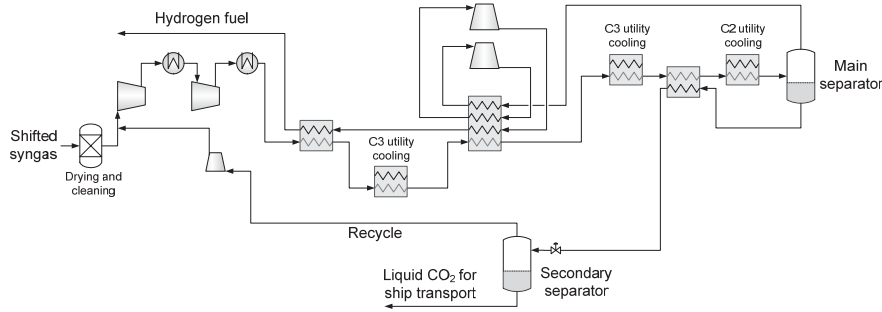

Fig. 2. Process flow diagram for the case of liquid CO₂ for ship transport.

2.2. Technical methodology

The syngas composition used in this work is given in Table 1. Details of the process as well as parameters and assumptions are given in Berstad et al. [2]. In order to obtain a high condensation ratio, and thus CCR, a sufficiently high pressure level is required. Additionally, the separation should be carried out at lowest practical temperature. Operation fully avoiding any solidification of CO₂ is assumed and consequently, the minimum separation temperature is governed by the CO₂ freezing point of the gas mixture at any given separation pressure – between 217 K (-56°C) and 220 K (-53°C) in this work, depending on desired temperature safety margin. Experimental vapour–liquid equilibrium (VLE) data for the H₂/CO₂ system in the temperature range 220–290 K is available from [3]. Based on the experimental VLE data, the obtainable CCR can be estimated, and the CCR for separation at 220 K is plotted as function of pressure in Fig. 3. As can be observed, approximately 85% CCR can be targeted at around 100 bar separation pressure. In this pressure range the discrepancy between results for experimental data and Peng–Robinson equation of state (EOS) is low, indicating that this EOS can be used for predicting CCR.

Steady-state simulations of the low-temperature CO₂ capture process were performed in Aspen HYSYS version 8.3 with Peng–Robinson equation of state.

Table 1. Syngas composition after H₂S removal and drying. Temperature and pressure is assumed to be 30°C and 35 bar, respectively.

Component	H ₂	CO ₂	CO	N ₂	Ar
Mol fraction	0.5375	0.3804	0.0160	0.0571	0.0090

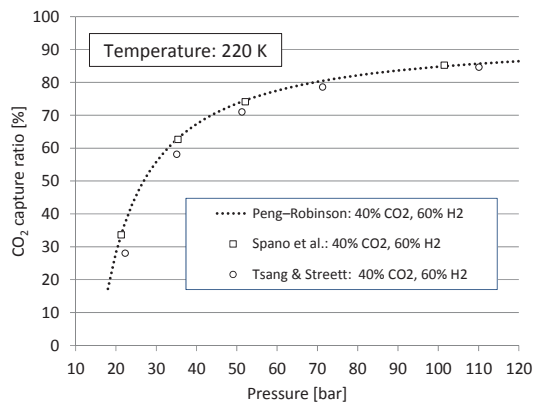

Fig. 3. Estimated CO₂ capture ratio for phase separation of syngas at 220 K (-53.15°C).

2.3. Cost assessment

In order to evaluate the potential of the low-temperature concept, the cost of an IGCC with CCS using low-temperature capture is compared to an IGCC without capture, as well as IGCC power plants with CCS using Selexol CO₂ capture for both pipeline and ship transport.

2.3.1. Cost evaluation methodology

The cost of an IGCC power plant equipped with low-temperature capture is evaluated for an 85% capture rate and compared to the cost of an IGCC power plant with and without Selexol CO₂ capture. This study assumes costs of a "NOAK" (Nth Of A Kind) plant to be built at some point in the future when the technology is mature. Investment and operating costs are given in 2008 prices which correspond to the reference costs year in the EBTF report [4] used as reference for costs of the IGCC power plant with Selexol capture.

The costs are based on the EBTF report [4] for the IGCC power plants and the Selexol capture facility while the low-temperature capture process is evaluated using Aspen Process Economic Analyzer for equipment costs and following the EBTF cost methodology in order to obtain consistent and comparable cost estimates. The EBTF average direct and indirect cost factors, the maintenance costs and utility costs of the IGCC plant with Selexol CO₂ capture are used to evaluate the investment cost of the IGCC with low-temperature CO₂ capture processes in this work.

The technical characteristics and costs associated with CO₂ conditioning are modelled using the BIGCCS transport modules previously presented and illustrated [5, 6].

2.3.2. Key Performance Indicators

The Levelized Cost Of Electricity (€/MWh) and the CO₂ avoidance cost (€/t_{CO2}) defined by Rubin et al. [7] are used as key performance indicators to measure the unitary cost of the electricity production and the unitary cost of CCS from an IGCC power plant, respectively, with and without CO₂ capture. The electricity production cost approximates the average discounted electricity price over the project duration that would be required as income to match the net present value of capital and operating costs for the project. The CO₂ avoided cost approximates the average discounted CO₂ tax or quota over the project duration that would be required as income to match the net present value of additional capital and operating costs due to the CCS infrastructure. The calculation of these KPIs considers a real discount rate of 8%[†], 7,500 operating hours per year and an economic lifetime of 25 years [4, 8].

To evaluate the chain cost per ton of CO₂ avoided in a consistent way, it is necessary to also include the carbon footprint of the full CCS chain. To be consistent with the EBTF methodology, only direct greenhouse gas emissions from burning fuels (coal [4] and shipping fuel [9]) are considered.

3. Results and discussion

In this section energy and cost results are summarised.

3.1. Energy results

The absolute power requirement as well as the specific power requirement (energy per unit of CO₂ captured) for the investigated pipeline CO₂ and liquid CO₂ cases, are summarised in Table 2. As can be observed, the specific power requirement is higher for producing liquid CO₂ for ship transport than for high-pressure CO₂ for pipe transport. This is mainly due to the higher requirement for auxiliary refrigeration due to lower degree of process-to-process heat recuperation in the liquid CO₂ case. By energy optimisation of the auxiliary refrigeration cycles, however, a 5–10% reduction in power requirement should be possible for the process generating liquid CO₂.

[†] This real discount rate of 8 % corresponds to a nominal discount rate around 10% if an inflation rate of 2% is considered.

Table 2. Energy results for the two investigated cases.

Design	Compressors	Expanders	Auxiliary refrigeration	Cooling water pumping	Recycle compression	CO ₂ pumping	Net specific power
	[kJ _e /kg _{CO2}]	[kJ _e /kg _{CO2}]	[kJ _e /kg _{CO2}]	[kJ _e /kg _{CO2}]	[kJ _e /kg _{CO2}]	[kJ _e /kg _{CO2}]	
Baseline ^a	279	119	67.6	2.55	14.0	18.2	275
Liquid CO ₂ ^b	276	110	125	3.6	13.9	—	321

^a Producing gaseous CO₂ at 150 bar for pipeline transport.

^b Producing liquid CO₂ at -56°C and 7.8 bar for ship transport.

3.2. Cost evaluation results

Based on the electricity output and the plant costs, the cost of electricity (LCOE) is used to compare the five power plant cases without or with capture, and for pipeline or ship transport as shown in Fig. 4. It is worth noting that at this stage neither transport nor storage costs are considered. The evaluation shows that the cost of electricity with low-temperature CO₂ capture is 23% more expensive than the plant without capture and is therefore 9% less expensive than the reference plant with Selexol CO₂ capture. When looking directly at the cost of capturing CO₂, the low-temperature concept for pipeline transport, with a cost of only 22 €/t_{CO₂ avoided}, is 35% more cost-efficient than the Selexol process.

For the capture process producing liquid CO₂ for ship transport, the cost of electricity with low-temperature CO₂ capture and internal CO₂ liquefaction is only 23% more expensive than the plant without capture. It is therefore 11% less expensive than the reference plant with Selexol CO₂ capture and liquefaction by ammonia cycles commonly used in the literature [10, 11]. When considering the CO₂ avoidance costs, the evaluation gives a capture cost, including liquefaction, of 23 €/2008/t_{CO₂ avoided}. This is 37% more cost-efficient than the Selexol process (38 €/2008/t_{CO₂ avoided}). This is primarily due to the already existing cost advantage of the process in the case of a pipeline export, and the extremely energy- and cost-efficient low-temperature internal liquefaction for ship transport compared to liquefaction by ammonia cycles.

The capture costs in the cases including liquefaction of CO₂ for ship transport are higher than for the pipeline CO₂ cases for both capture technologies. However, these results cannot be compared directly as the transport systems cost are not included in the numbers.

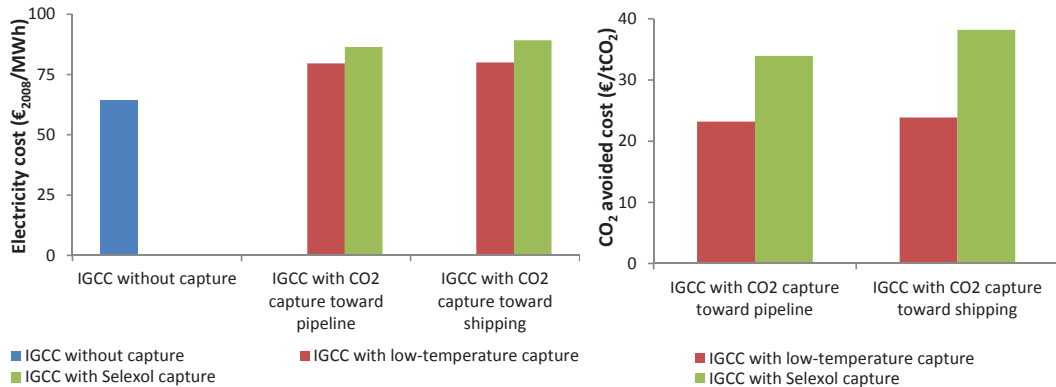

Fig. 4. Electricity cost (a) and CO₂ avoided cost (b) of the five IGCC power plant cases with and without CCS.

4. Conclusions and further work

Process designs for low-temperature CO₂ capture from IGCC using CO₂ liquefaction have been presented. Steady-state simulations and techno-economic analysis have been performed to identify the performance of the

system. The specific power requirement for the base case has been calculated to 275 kJ/kg_{CO₂} for a CO₂ capture rate of 85%. The CO₂ product from this configuration is high-pressure gas at 150 bar for pipeline transport. Another process configuration was designed and simulated for producing cold liquid CO₂ at around 8 bar for ship transport. The specific power requirement for this configuration is calculated to 321 kJ/kg_{CO₂}, which is roughly 17% higher than for the base case. However, this figure should be possible to improve by optimisation of the auxiliary refrigeration cycles.

An economic benchmarking of the two processes has been performed with Selexol process as the reference case. The levelized cost of electricity for the two CO₂ liquefaction processes are 9% and 11% lower than the corresponding Selexol cases while the CO₂ capture cost are 35% and 37% lower than the corresponding Selexol cases.

The results presented show that CO₂ capture by liquefaction in an IGCC process is both cost and energy efficient compared to the Selexol process. A systematic CCS chain approach, including capture, transport and storage, should therefore be performed in order to evaluate the full cost of this concept and if the low-temperature concept lead to additional synergy opportunities with the transport technologies.

Acknowledgements

This publication has been produced with support from the BIGCCS Centre, performed under the Norwegian research program Centres for Environment-friendly Energy Research (FME). The authors acknowledge the following partners for their contributions: ConocoPhillips, Gassco, Shell, Statoil, TOTAL, GDF SUEZ and the Research Council of Norway (193816/S60).

References

- [1] Berstad D, Anantharaman R, Nekså P. Low-temperature CO₂ capture technologies – Applications and potential. *International Journal of Refrigeration*. 2013;36:1403-16.
- [2] Berstad D, Anantharaman R, Nekså P. Low-temperature CCS from an IGCC Power Plant and Comparison with Physical Solvents. *Energy Procedia*. 2013;37:2204-11.
- [3] Tsang CY, Street WB. Phase equilibria in the H₂/CO₂ system at temperatures from 220 to 290 K and pressures to 172 MPa. *Chemical Engineering Science*. 1981;36:993-1000.
- [4] Anantharaman R, Bolland O, Booth N, Dorst EV, Ekstrom C, Franco F, et al. D1.4.3 European best practice guidelines for assessment of CO₂ capture technologies. DECARBit Project; 2011.
- [5] Roussanaly S, Jakobsen JP, Hognes EH, Brunsvold AL. Benchmarking of CO₂ transport technologies: Part I— Onshore pipeline and shipping between two onshore areas. *International Journal of Greenhouse Gas Control*. 2013;19C.
- [6] Roussanaly S, Brunsvold AL, Hognes ES. Benchmarking of CO₂ transport technologies: Part II – Offshore pipeline and shipping to an offshore site. *International Journal of Greenhouse Gas Control*. 2014;28:283-99.
- [7] Rubin E, Booras G, Davison J, Ekstrom C, Matuszewski M, McCoy ST, et al. Toward a common method of the cost estimation for CO₂ capture and storage at fossil fuel power plants. *Global CCS institute*; 2013.
- [8] Roussanaly S, Brunsvold AL, Hognes ES, Jakobsen JP, Zhang X. Integrated Techno-economic and Environmental Assessment of an Amine-based Capture. *Energy Procedia*. 2013;37:2453-61.
- [9] EcoInvent. Ecoinvent life cycle inventory database v2.2: The ecoinvent Centre. Swiss center for life cycle inventories. Available from: www.ecoinvent.org; 2012.
- [10] Alabdulkarem A, Hwang Y, Radermacher R. Development of CO₂ liquefaction cycles for CO₂ sequestration. *Applied Thermal Engineering*. 2012;33-34:144-56.
- [11] Roussanaly S, Bureau-Cauchois G, Husebye J. Costs benchmark of CO₂ transport technologies for a group of various size industries. *International Journal of Greenhouse Gas control*. 2013;12C:341–50.