

How do selectins mediate leukocyte rolling in venules?

Aydin Tözeren* and Klaus Ley†

*Department of Mechanical Engineering, The Catholic University of America, Washington, D.C. 20064 USA; and

†The Institut für Physiologie, Freie Universität Berlin, Berlin 33, Germany

ABSTRACT At the onset of inflammation, 20–80% of all leukocytes passing postcapillary venules roll along the endothelium. Recent blocking experiments with antibodies and soluble adhesion receptor molecules, as well as in vitro reconstitution experiments, suggest that leukocyte rolling is mediated by adhesion molecules that belong to the selectin family. What differentiates a selectin-counterreceptor interaction that leads to leukocyte rolling from others that mediate firm adhesion after static incubation but no adhesion when incubated under flow conditions? Here, we explore this question by introducing a quantitative biophysical model that is compatible with the laws of mechanics as applied to rolling leukocytes and the present biochemical and biophysical data on selectin mediated interactions. Our computational experiments point to an adhesion mechanism in which the rate of bond formation is high and the detachment rate low, except at the rear of the contact area where the stretched bonds detach at a high uniform rate. The bond length and bond flexibility play a critical role in enhancing leukocyte rolling at a wide range of fluid shear rates.

INTRODUCTION

Intravital microscopy studies established that some leukocytes roll along the endothelium in postcapillary venules (Cohnheim, 1877; Atherton and Born, 1973; Firrell and Lipowski, 1989). Leukocyte rolling may be a requisite first step for the migration of these cells into tissues during inflammatory response (Atherton and Born, 1973; Fiebig et al., 1991). On chemotactic stimulation by inflammatory mediators, their movement is halted at intervals until they stick to the endothelial cells. Leukocytes then deviate from their round shapes by flattening against the endothelial cells and by extending a pseudopod into an endothelial cell junction (Marchesi, 1961). This is followed by the transmigration of the leukocyte through a narrow gap between endothelial cells.

Recent blocking experiments with soluble recombinant receptor molecules (Ley et al., 1991) or monoclonal antibodies (von Andrian et al., 1991) in vivo show that leukocyte rolling on vascular endothelial cells is mediated by adhesion receptors that belong to the selectin family. Similar results were obtained in experiments in vitro using granulocytes on cytokine-activated endothelial cells (Abbassi et al., 1991) or on purified P-selectin incorporated into lipid bilayers (Lawrence and Springer, 1991). There are three known selectin molecules: L-selectin or LECAM-1, which is expressed on all leukocytes; E-selectin or ELAM-1, which is induced on cytokine stimulated endothelial cells; and P-selectin or CD62 (PADGEM, GMP140), which is expressed by endothelial cells and platelets on activation by mediators of inflammation and hemostasis (for review, see Springer, 1990; McEver, 1991; Bevilacqua et al., 1991). Amino acid sequence of known selectin molecules identify six structural domains, including a lectin-like binding domain, an epidermal growth factor domain, regulatory protein repeats (consensus repeat motifs), a transmembrane domain, and a cytoplasmic domain. Most of the protein is located on the extracellular side. Selectins vary in length as a result of the varying number of short con-

sensus repeat units in their structure. The longest is P-selectin with nine consensus repeat motifs. Its extracellular length is $\cong 40$ nm. The corresponding value for E-selectin is 30 nm, reflecting the fact that this molecule has six repeat motifs. L-selectin, the shortest known selectin (15 nm), has only two consensus repeat motifs.

At shear rates in the low venular range, neutrophils roll on glass supported lipid-bilayers containing purified P-selectin molecules (Lawrence and Springer, 1991). On the other hand, under similar situations, neutrophils do not roll on or stick to planar membranes reconstituted with the intercellular adhesion molecule ICAM-1 even when they are stimulated with a phorbol ester (Lawrence and Springer, 1991). If, however, these activated neutrophils are allowed to settle on the planar membrane in the absence of fluid shear force, resulting adhesion is stronger than adhesion to a planar membrane containing P-selectin molecules at a comparable surface density.

What differentiates selectin bonds that mediate leukocyte rolling from other leukocyte adhesion bonds that mediate stable adhesion after static incubation? To explore this question, we present here a model for the micromechanics of leukocyte rolling that is consistent with the present biochemical and biophysical data.

This model can be used to test (a) whether steady-state rolling is possible for a set of bond parameters that describe the molecular properties of the surface adhesion molecules and, if so, (b) whether the steady rolling velocity of the modeled leukocyte is comparable with the corresponding experimental observations.

MICROMECHANICS OF LEUKOCYTE ROLLING IN A SHEAR FLOW

The biophysical model of leukocyte rolling introduced here is based on the following assumptions.

(a) Leukocytes rolling at low shear rates are approxi-

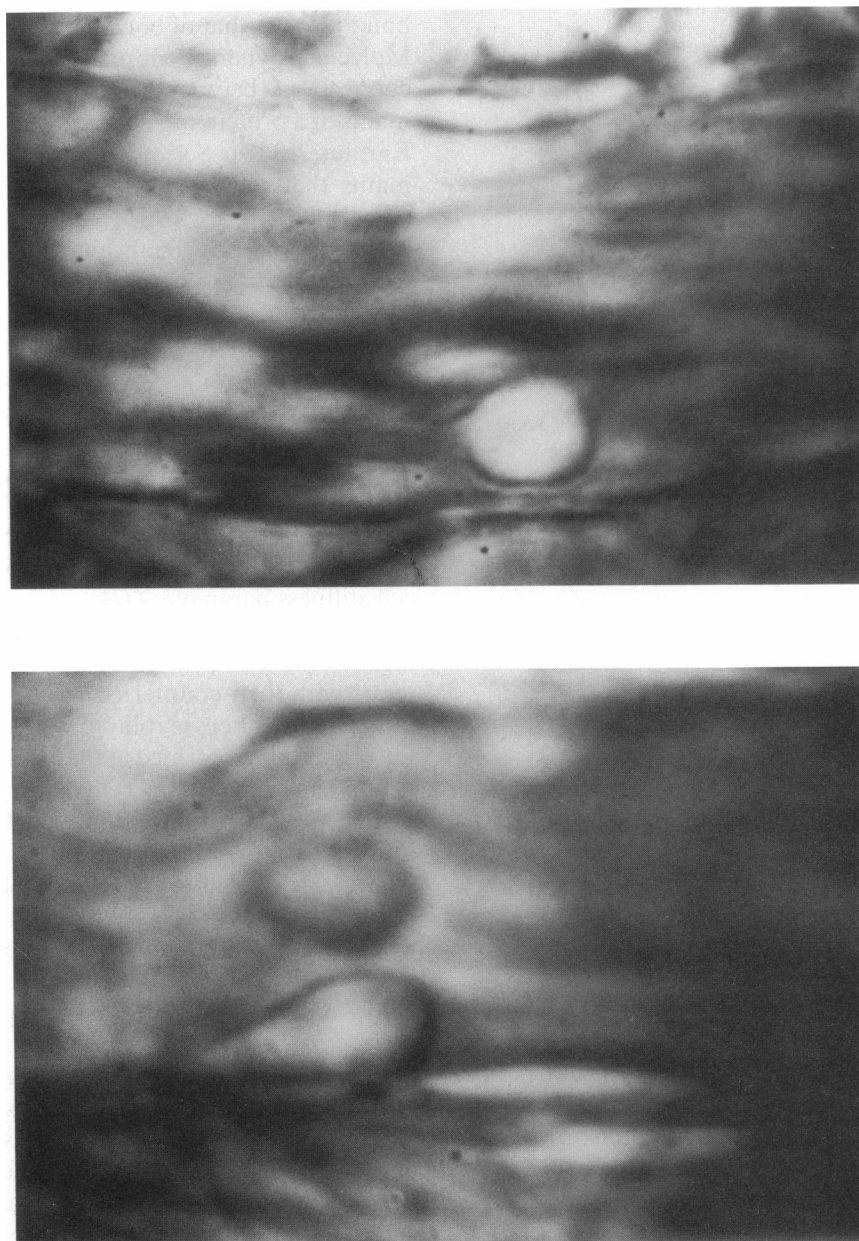

FIGURE 1 Leukocytes rolling in venules of rat mesentery. (Top) Micrograph of a rolling leukocyte at a wall shear stress τ of 2.2 dyn/cm². (Bottom) Micrograph of a leukocyte tanktreading in a venule at $\tau = 7.2$ dyn/cm².

mately spherical in shape as noted by Firrell and Lipowski (1989). The videomicrographs shown in Fig. 1 indicate that leukocytes rolling on the surface of a venule of rat mesentery tend to elongate in the direction of flow with increasing fluid shear stress. The ratio of cell length in the direction of flow to that in the direction perpendicular to flow is equal to 1.26 ± 0.13 (11 measurements) when the shear stress on vascular endothelium is equal to 2.2 dyn/cm². This elongation index increases to 1.52 ± 0.13 (11 measurements) due to an approximately three-fold increase in the wall shear stress.

In this study, the rolling leukocytes are assumed to be spherical in the computations of the fluid force and mo-

ment acting on the cell at small flow rates. For numerical simplicity, the spherical surface in the contact area is replaced with a finite cylinder of the same radius (see Appendix for details).

(b) The net force and moment on a leukocyte is equal to zero due to the fact the Reynolds number is low and the inertial forces are negligible (Fung, 1984). The force and the moment exerted by the surrounding fluid on the rolling cell can be computed by using the known solutions of slow viscous flow around a sphere that is in close vicinity of a planar wall (Goldman et al., 1967*a, b*) (Fig. 2). The nonspecific repulsive force between the rolling cell and the substrate acts in the direction perpendicular

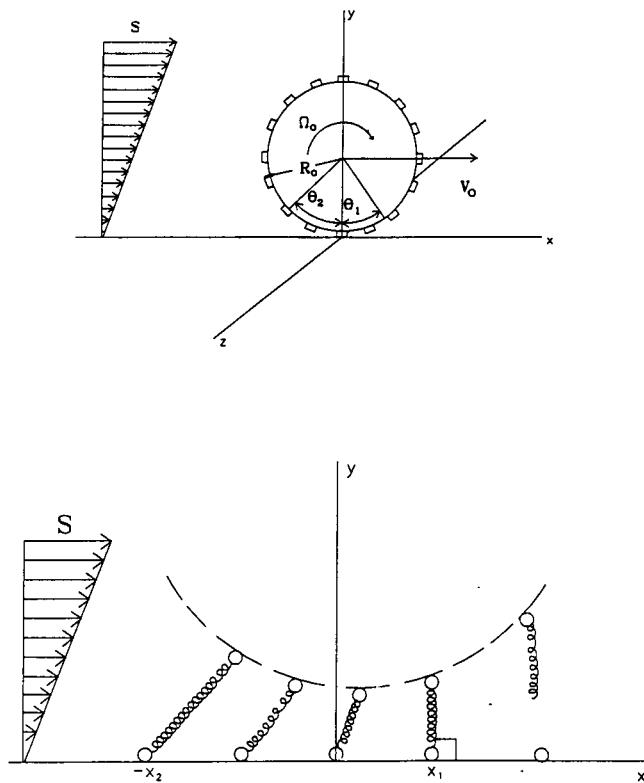

FIGURE 2 The schematic diagram of a leukocyte rolling on a vascular endothelium. (Top) Geometric parameters used in the analysis are shown. (Bottom) Configuration of adhesion bonds in the contact area is shown schematically.

to the substrate, and it can be evaluated by using the equation given by Bell et al. (1984).

(c) The surface of a typical white cell is not smooth when examined under electron microscopy but contains numerous membrane folds and microvillous processes (Schmid-Schönbein, 1990). A typical leukocyte forms contacts with the substrate through these cell surface projections (Picker et al., 1991). In accordance with these observations, it is assumed that there will be an effective fluid layer between the cell and the substrate, and the thickness of this fluid gap is equal to the typical length of the cell surface projections (H_0). This assumption enables us to compute the fluid force and moment acting on a rolling cell by using the Tables in Goldman et al. (1967). Note also that the velocity of a spherical cell approaches zero as the gap thickness between the cell and the substrate approach zero. Nonetheless, the fluid force and the fluid moment acting on the cell is insensitive to the value of H_0 when $0.03 \times R_0 < H_0 < 0.12 \times R_0$, where R_0 is the mean radius of the cell.

(d) The selectin-counterreceptor bonds formed between a rolling cell and its substrate cannot resist compression (like strings and ropes) but resist tensile force in proportion to their lengthwise extension when stretched beyond their equilibrium configuration. The bond stiffness in tension κ (dyn/cm) is defined as the ratio of the

bond force to that of bond extension (Bell et al., 1984). Molecular dynamic simulation studies indicate that the connections between various motifs (loops) and domains of a protein molecule are quite flexible (Elber and Karplus, 1987). Selectin molecules have multiple domains (Bevilacqua et al., 1991), suggesting that these molecules can undergo significant shortening through buckling, i.e., the rotation of the glycoprotein domains with respect to each other.

(e) The cell poker experiments performed on leukocytes show that the force resisted by a leukocyte increases approximately linearly with the cell deformation at a rate of $G \cong 1.5$ dyn/cm (Pasternak and Elson, 1985). It is possible that the surface projections connecting the adhesion bonds to the main body of the cell may also increase in length in proportion to the tensile bond force. This is accounted for in the model by introducing a local cell stiffness parameter (G).

(f) In the model, we assume that the adhesion receptors of only one type (i.e., P-selectins or E-selectins) interact with their counterreceptors on the leukocyte surface during leukocyte rolling. We assume further that an unstressed bond, formed at the leading edge of the conjugation between a rolling cell and its substrate, is perpendicular to the substrate. Bond length at any location in the contact area is then computed by using the known kinematics of rolling (Beer and Johnston, 1984). This assumption amounts to lumping all bond configurations with the same bond length into one bond state.

(g) The kinematics of rolling (Beer and Johnston, 1984) dictates that the adhesion bonds are first compressed and then stretched during rolling (Fig. 2). The fluid drag force acting on the rolling cell in the direction of flow tends to orient these bonds toward the leading edge of conjugation, resulting in a small amount of apparent slip velocity between the leukocyte and its substrate. Slip velocity is defined here as the velocity of that end of an adhesion bond that is embedded into the leukocyte cell membrane relative to the substrate.

(h) In the model, adhesion receptors are assumed to have local mobility, necessary for bond formation, but the possibility of redistribution of adhesion bonds in the contact region because of receptor diffusivity is considered unlikely. Previous computations on T cell target cell interaction indicate that the time needed for redistribution of adhesion receptors on the cell surface is significantly greater than the fraction of a second, the average life time of an adhesion bond in the contact area of a rolling leukocyte (Tözeren, 1990).

(i) The formation and the detachment of unstressed bonds between selectins (of a given type) and their counterreceptors are assumed to be governed by a bimolecular reaction, as suggested by the results of Moore et al. (1991). The stretched bonds (carrying tensile force) are assumed to break at a uniform rate as in Dembo et al. (1988). This detachment rate is determined not from

biochemical data but by curve fitting the model predictions to the experimental data on rolling velocity vs. fluid shear stress (Lawrence and Springer, 1991; Ley et al., 1991). Furthermore, this debonding process is modeled as irreversible. The condition of detailed balance requires that the rate of bond formation must be finite at least in the range when the bond length is slightly greater than the unstressed length. Our computations not shown here indicate, however, that the treatment of the detachment as a reversible process for stretched bonds have negligible effect on the computed relation between the rolling velocity and the wall shear rate.

(j) A stretched bond is assumed to fail (it can no longer exert force) if it debonds as discussed above or one of the glycoproteins forming the bond is uprooted from its membrane. Using the known free energy changes due to displacement of hydrophobic residues into aqueous environment and polar residues into lipid-bilayer, Bell (1978) estimated that the force to uproot glycoprotein molecules from the cell membrane to be $\sim 10^{-5}$ dyn. More recently, Evans et al. (1991) studied the detachment of agglutinin bonded red cells by using a micromanipulation method. These authors deduced from their data that the forces of $1-2 \times 10^{-6}$ dyn may be sufficient to rupture molecular-point attachments. Since the number of residues in the transmembrane and cytoplasmic components of P-selectin (Johnston et al., 1989) are similar to that for glycoproteins, the estimate by Bell (1978) may be reasonable for the maximum force a selectin bond can sustain before it fails (f_m). The yield bond length at which the bond fails (l_m) is then equal to f_m/κ , where κ (dyn/cm) is the bond stiffness.

(k) In the model described above, the component of the resultant bond force acting on the cell in the direction perpendicular to the substrate is balanced by the resultant nonspecific repulsive force between the rolling cell and the substrate. A small but finite velocity of one end of an adhesion bond relative to another results in the orientation of the adhesion bonds toward the leading edge of conjugation, allowing these bonds to resist the fluid force acting in the direction of flow. Finally, the fluid moment that tends to accelerate the rotation of the rolling cell is balanced by the moment generated by stretched bonds. The mathematical details of the model and the computational method used is described in the Appendix. The bond parameters that appear in the model are tabulated in Table 1.

We have used the biophysical model introduced here to compute the uniform velocity of a leukocyte rolling on a substrate in shear flow as a function of wall shear stress for prescribed values of bond parameters. Model equations for steady-state rolling do not necessarily have a solution when the bond parameters are assigned arbitrary values within biophysically reasonable range of parameter values. In cases where no solution exists, it is possible that leukocytes could interact intermittently with the vascular endothelium.

The biophysical mechanism introduced here for the selectin-mediated rolling is likely to be the simplest model compatible with experimental data. We considered a number of other bond models to see whether they would lead to leukocyte rolling. An adhesion mechanism, in which the rate of bond formation decreased toward zero with the extent of bond compression and the bond stiffness in compression was comparable with that in tension, did not lead to predictions compatible with the experimental data discussed below.

RESULTS AND DISCUSSION

Comparison of model predictions with experimental data on rolling velocity versus fluid shear stress

We compared, in the top panel of Fig. 3, the predictions of the biophysical model introduced here with the mean neutrophil velocity vs. fluid shear stress measurements obtained by Lawrence and Springer (1991) in an in vitro laminar flow assay. In these experiments, the planar lipid-bilayers, on which neutrophils rolled, contained P-selectin molecules at three different concentrations (50, 200, and 400 sites/ μm^2). The figure shows that the model predicts leukocyte velocities within the range of experimental data and reproduces the effect of the surface density of endothelial adhesion molecules on the rolling velocity of leukocytes. The parameter values for the model predictions shown in the top panel of Fig. 3 (50 P-selectin molecules/ μm^2) are tabulated in Table 1 as control values. These input parameter values are in good agreement with the corresponding estimates (also shown in Table 1) obtained by other groups through experimental methods or biophysical calculations.

The mean velocity of leukocytes rolling in venules of rat mesentery are shown in the bottom panel of Fig. 3. The discrete points in the figure are the average values of 8–20 independent measurements in a venule. The figure shows that in vivo leukocyte rolling velocity values are significantly greater than that obtained in a reconstitution experiment. Also shown in the bottom panel of Fig. 3 is the model prediction corresponding to parameter values identical to that given in Table 1 with one exception: the typical length of the nonspecific repulsion was increased twofold to mimic the replacement of the planar lipid-bilayer as the substrate with that of a glycocalyx coated endothelial layer. The comparison of the theoretical curves in the top and the bottom panels of Fig. 3 shows that an increase in nonspecific repulsion leads to a significant increase in leukocyte velocity. The model presented here predicts rolling velocities in the in vivo range by either increasing the nonspecific repulsion parameter or decreasing the surface concentrations of the interacting adhesion molecules. The other factors that effect the rolling velocity will be discussed in the next subsection.

TABLE 1 Parameters of selectin mediated leukocyte rolling

Parameter	Definition	Control values	Range/best estimate	Reference
l_o	Unstrained bond length	50 nm	30–50 nm	Springer, 1990
κ	Bond stiffness	2 dyn/cm	0.1–10 dyn-cm	Bell et al., 1984
k_m^+	Rate of formation of unstressed bonds	1 $\mu\text{m}^2/\text{s}$	0.06–0.6 $\mu\text{m}^2/\text{s}$	Moore et al., 1991*
k_m^-	Rate of detachment of unstressed bonds	$0.5 \times 10^{-4} \text{ s}^{-1}$	$0.5\text{--}5 \times 10^{-4} \text{ s}^{-1}$	Moore et al., 1991*
g	Rate of detachment of stressed bonds	30 s^{-1}	—	—
f_m	Yield bond force	$2 \times 10^{-5} \text{ dyn}$	10^{-5} dyn	Bell, 1978
m_1	Surface density of neutrophil receptors	250 sites/ μm^2	150–250 sites/ μm^2	Moore et al., 1991
m_2	Surface density of endothelial receptors	50 sites/ μm^2	50–400 sites/ μm^2	Lawrence and Springer, 1991
R_o	Typical radius of a neutrophil	3.5 μm	3–4 μm	Schmid-Schonbein, 1990
H_o	Typical thickness of neutrophil surface roughness	$0.12R_o$	$0.05\text{--}0.20R_o$	Schmid-Schonbein, 1990
γ	Nonspecific repulsion intensity constant	10^{-6} dyn	$10^{-5}\text{--}10^{-7} \text{ dyn}$	Bell et al., 1984
ω	Typical length of nonspecific repulsion	10 nm	10–30 nm	Bell et al., 1984 Springer, 1990
G	Local cell stiffness	1.5 dyn/cm	$\sim 1.5 \text{ dyn/cm}$	Pasternak and Elson, 1985

* These rate parameters were determined from Moore et al. (1991) by using the method of Bell (1978).

In the computational experiments shown in Fig. 3, the predicted slip velocity was <2% of the total cell velocity (see Table 2). This is consistent with our experimental findings. The velocity of a leukocyte rolling in a venule of a rat mesentery (V_o) is $\cong 16.7 \pm 10.5 \mu\text{m/s}$ (11 measurements) when the fluid shear stress on venule wall (τ) is $\sim 2.2 \text{ dyn/cm}^2$. The rolling velocity of the cell (V_r), evaluated by dividing the apparent circumference of the cell (as observed from the side view) to the time for one complete rotation, is equal to $16.2 \pm 9.7 \mu\text{m/s}$ at the same fluid shear stress level. Spherical cells roll without slip when $V_o = V_r$. The predicted leukocyte velocities shown in Fig. 3 are ≥ 10 -fold smaller than the corresponding neutrally buoyant spheres under similar flow conditions (Goldman et al., 1967b). When the fluid shear stress (τ) is taken to be $< 0.4 \text{ dyn/cm}^2$ in the computations, the predicted cell velocity approaches toward zero, but that the slip velocity is no longer much smaller than the mean leukocyte velocity. This is expected, since, as τ goes to zero, the bond force and the bond moment acting on the cell also diminish toward zero and the rolling cell behaves more like a neutrally buoyant particle.

We plotted in Fig. 4 the surface density of the adhesion bonds in the contact zone in the direction of flow for the numerical experiment shown in the bottom panel of Fig. 3 at two different levels of fluid shear stress ($\tau = 0.8, 2.0 \text{ dyn/cm}^2$). The figure shows that the surface density of bonds reach the same maximum in both cases but that the number of stretched bonds in the detachment zone increases with increasing fluid shear stress. Note also in Fig. 4 that the modeled length of the contact zone varies with the fluid shear stress. This is due to the predicted

reduction in the gap distance between the rolling cell and the substrate (y_o) with increasing wall shear stress (see Table 2).

Fig. 4 shows also that a small fraction of the adhesion bonds in the contact zone may be pulled out of the membranes at low shear rates (<8% for $\tau = 0.8 \text{ dyn/cm}^2$). Since the contact area is only a small fraction of the surface area of a leukocyte, no significant receptor depletion is predicted before these cells roll distances many times greater than the cell diameter.

Role of biophysical parameters of adhesion bonds on the speed of rolling leukocytes at a given fluid shear stress

L-selectin molecules may have an important role in mediating the rolling of polymorphonuclear neutrophils on inflamed venules by interacting with E-selectin and P-selectin molecules on the surface of vascular endothelium (Picker et al., 1991). Since the molecular strengths of E-selectins ($\sim 30 \text{ nm}$) and P-selectins ($\sim 40 \text{ nm}$) are different (Springer, 1990), the lengths of the adhesion bonds formed by these receptors may also be different. In a set of computational experiments, we varied the bond length assumed in the model systematically while keeping the other bond parameters constant. The predicted velocities of rolling cells at a fluid wall shear stress of 2 dyn/cm^2 are 24, 17, and $14 \mu\text{m/s}$ when the unstressed bond length is taken as 30, 40, or 50 nm, respectively. Furthermore, for the control parameter values shown in Table 1, it was not possible to obtain a solution of the model equations when the unstrained bond length

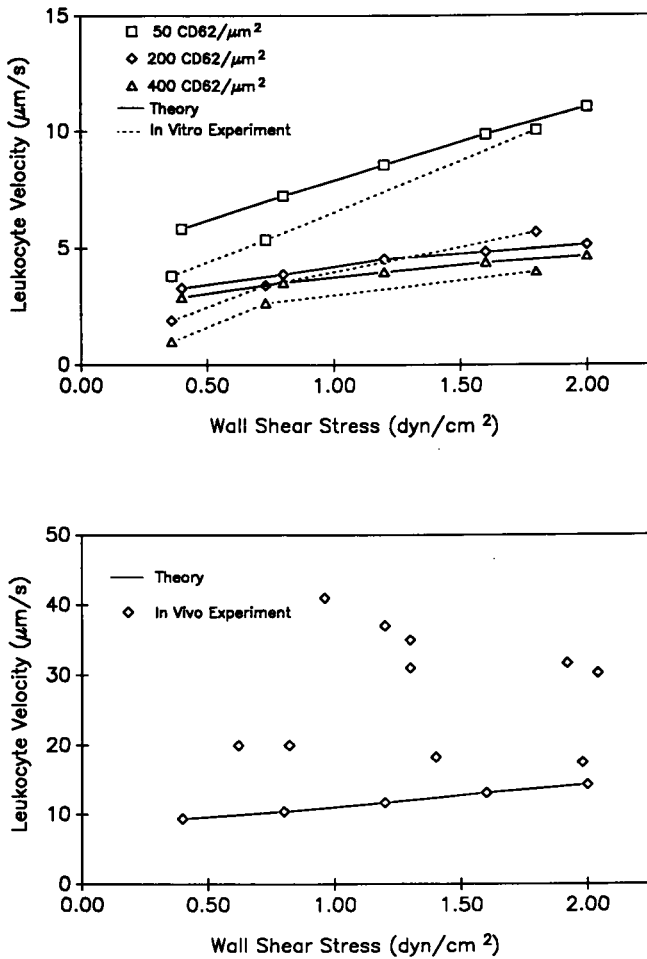

FIGURE 3 Neutrophils rolling on planar lipid-bilayers containing purified receptors (*top*). The data shown in the top of the figure was reproduced from Lawrence and Springer (1991). Leukocytes rolling on blood venules of rat mesentery (*bottom*). The discrete points show the experimental data obtained by Ley and Gaehgtgens (1991).

was reduced to 25 nm. The scale models of immunoglobulin receptors indicate that the optimum bond length for CD2-LFA-3 interaction is ~ 13 nm (Springer, 1990). This short bond length may be one of the factors why this adhesion pathway does not lead to lymphocyte rolling in a shear flow.

Our computations point to the following mechanism of action of the bond length on rolling velocity. The contact area between the rolling cell and the substrate decreases with decreasing bond length (see Eq. A3 in the Appendix), resulting in reductions of the number of bonds and the moment arms of the bond forces with respect to the cell center. To compensate for this, the modeled leukocyte rolls with higher angular velocity, retarding the decay of the adhesion bonds that are in tension.

Among other factors that increase the velocity of rolling cells are a reduction in bond stiffness (κ) and a reduction in the bond yield force (f_m) from their control values shown in Table 1. When the parameter κ was reduced twofold in the computations, predicted leukocyte velocity increased from 14 to 39 $\mu\text{m/s}$. Similarly, a reduction in f_m from 2 to 1.5×10^{-5} dyn led to 35% increase in the predicted leukocyte velocity.

Dembo et al. (1988) estimated that the local deformability of the leukocyte surface may not play a significant role in determining the rolling velocity for spherical cells. Consistent with this prediction, when the local cell stiffness (G) was increased in our computations, fivefold from its control value shown in Table 1, the resulting increase in leukocyte velocity was negligible ($\sim 2\%$) at a shear stress of 2 dyn/cm^2 . At shear stresses greater than the range considered here, leukocytes adapt in shape to the surrounding flow conditions as shown in the bottom panel of Fig. 1. Firrell and Lipowski (1989) attributed the relative insensitivity of the cell rolling velocity (to the shear rate) to the increase in the contact area with elevations in shear rate.

Effects of rates of attachment and detachment on the rolling velocity

Recent radioligand binding assay studies indicate that soluble P-selectin binding to neutrophils is Ca^{2+} dependent, reversible, and saturable at 3–6 nM free P-selectin (Moore et al., 1991). The estimates of the binding affinity and the rate constants of bond formation and bond breakage obtained in the Appendix from the data of Moore et al. (1991) may not be accurate, however, be-

TABLE 2 Kinematic parameters of rolling adhesion as a function of fluid shear stress

τ	CPV			I			II		
	y_0	V_s	V_o	y_0	V_s	V_o	y_0	V_s	V_o
<i>dyn/cm²</i>									
0.4	30.1	0.06	5.5	28.0	0.02	3.0	46.0	0.16	9.4
0.8	25.5	0.09	7.0	23.7	0.03	3.2	40.4	0.16	10.2
1.2	22.9	0.11	8.4	21.3	0.04	3.9	36.0	0.17	11.3
1.6	21.1	0.13	9.6	19.7	0.04	4.3	32.8	0.19	12.4
2.0	19.7	0.15	10.8	18.4	0.04	4.7	30.4	0.20	13.5

τ , fluid shear stress acting on the substrate; CPV, Parameter values shown in Table 1; I, CPV with one exception (400 CD62/μm²); II, CPV with one exception ($\omega = 20$ nm); y_0 (nm), minimum distance between the rolling cell and the substrate; V_s ($\mu\text{m/s}$), slip velocity; V_o ($\mu\text{m/s}$), leukocyte velocity.

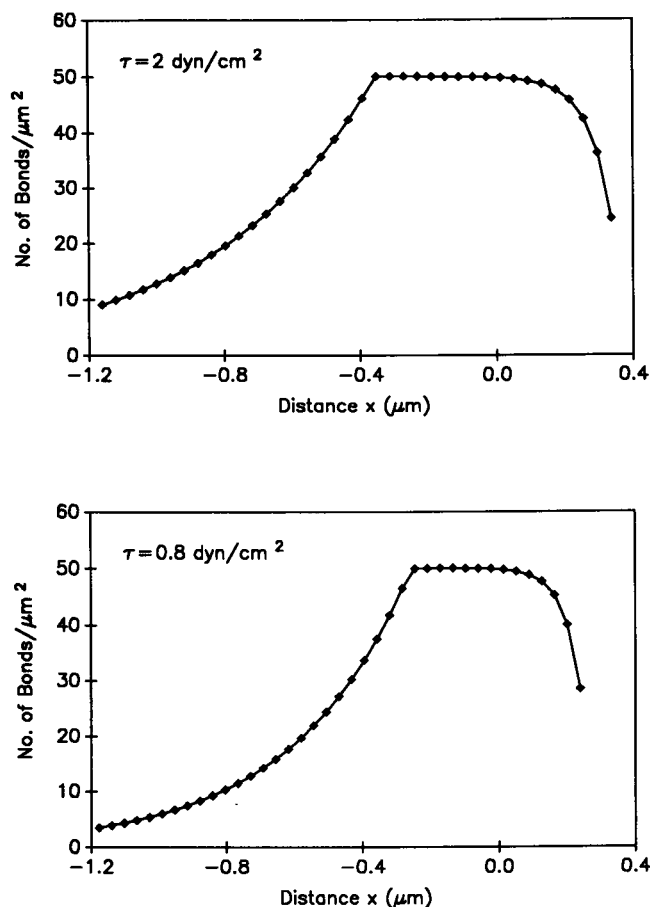

FIGURE 4 The surface density of adhesion bonds as a function of distance along the vascular endothelium (x) for the parameter values corresponding to the theoretical graph I in the bottom panel of Fig. 3.

cause soluble P-selectin molecules used in the experiments showed heterogeneous sedimentation, suggesting that a percentage of P-selectin molecules may have formed oligomers in the solution. Using a recombinant form of P-selectin in similar quantitative binding experiments, Aruffo et al. (1991) recorded 20-fold greater concentrations at half-maximal binding. Furthermore, not all leukocyte surface receptors that specifically bind to soluble P-selectins will be available for binding during cell-cell interaction due to the complex topology of the leukocyte surface and the differential distribution of the P-selectin counterreceptors on that surface (Picker et al., 1991).

For these reasons, we investigated the role of the rate parameters in determining leukocyte velocity at a given fluid shear stress. A hundredfold increase in the reverse rate constant for unstressed bonds (k_{mo}^-) (and therefore 100-fold decrease in binding affinity) from its value tabulated in Table 1 had a negligible effect on the results. Similarly, a 10-fold increase in the forward rate constant practically had no effect on the rolling velocity. It is evident from Fig. 4 that the surface density of bonds have saturated for the shear rates considered in this study.

This may be the reason why the further increase in the value of the forward rate constant had no effect on rolling velocity.

If the forward rate constant was decreased fourfold, the resulting increase in cell velocity was not significant (7%). An eightfold reduction in the value of the forward rate for bond formation resulted, on the other hand, in a 70% increase in the rolling velocity. We were not able to obtain a solution for the model equations of steady-state rolling when the forward rate was further reduced. These computational results suggest that steady-state rolling is possible when the forward rate is sufficiently large even if the dissociation constant for bimolecular bond formation is $\sim 10^{-6}$ M.

In conclusion, the bond parameter values that are compatible with the rolling adhesion data point to a bond mechanism in which (a) the rate of bond formation is large enough for bonds to form in the short duration when the adhesion receptors are in the vicinity of the contact area (~ 0.02 – 0.10 s); (b) bonds undergo significant extension before they fail to carry force; and (c) the rate of bond detachment is significantly higher for stretched bonds than suggested by biochemical experiments involving soluble adhesion molecules (Moore et al., 1991).

Recently, Dembo et al. (1988) proposed peel analysis for leukocytes rolling on vascular endothelium. This is a logical choice for high shear rates at which the cell shape adapts to the surrounding flow conditions (Fig. 1). Then, the fluid moment becomes no longer an important factor for rolling. Similarly, the rate of bond formation is not a critical parameter that effects rolling at high shear rates, since the time period, during which adhesion receptors embedded on the opposing cell membranes can interact to form bonds, increases with increasing contact area.

The presently available computational techniques do not yet facilitate an accurate evaluation of the correlation between the cell membrane tension at the edge of the conjugation (peel tension) and the flow conditions surrounding the cell. For this reason, Dembo et al. (1988) assumed that the peel tension at the detachment zone is proportional to the mean velocity of blood in a vessel. With this assumption, the model predictions could be compared with the data presented by Atherton and Born (1973) on rolling velocity for wide ranges of flow rates. This comparison led to the prediction that the bonds stretched at the edge of conjugation detach at a high rate and that this rate is insensitive to the bond strain. Our findings are consistent with this prediction.

APPENDIX

Measurements of leukocyte rolling velocity

The videomicrographs of leukocytes rolling in venules of the rat mesentery were obtained by using intravital microscopy at high magnifica-

tion (objective, 50/1.00 W, projection eyepiece, 2.0×; E. Leitz Inc., Rockleigh, NJ) as described in Ley and Gaehgtens (1991). The translational velocities of rolling leukocytes were obtained by measuring the distance travelled by the leading edge of the projection of a sharply focused cell during a period of several video frames. The velocities thus quantified were ~10-fold smaller than that of neutrally buoyant spheres under similar flow conditions (Lawrence and Springer, 1991). The rotational velocity was determined by dividing the apparent circumference of the projection of the cell by the time required for one complete rotation of the cell (as determined by following the trajectory of a granule in the vicinity of the cell membrane). The fluid shear stress on the venule wall was calculated from the measured center-line velocity by assuming Poiseuille flow in a circular tube and a fluid viscosity of 0.02 dyn-s/cm² (Lipowski et al., 1980).

Kinematics of rolling

Consider a rigid sphere of radius R_0 that rolls with angular velocity Ω_0 as it travels from left to right as shown in Fig. 2. Let (x, y, z) denote the cartesian coordinates moving with the center of the sphere at a uniform speed V_0 . The cell is closest to the substrate at $x = 0$.

Assume that the contact area between the rolling sphere and the planar substrate is restricted to a small domain bounded by angles $-\theta_2$ and θ_1 (Fig. 2, top) so that $\sin \theta$ and $\cos \theta$ can be approximated as θ and $1 - \theta^2/2$, respectively. Using the equations of kinematics (Beer and Johnston, 1984), one can then show that the displacement (Δ_x, Δ_y) of a material point (a surface receptor) on the surface of the sphere in the domain $(-\theta_2, \theta_1)$ can be written as:

$$\Delta_x = -(x - x_1)V_s/(V_0 - V_s) \quad (\text{A1})$$

$$\Delta_y = (x^2 - x_1^2)/2R_0, \quad (\text{A2})$$

where $V_s = V_0 - \Omega_0 R_0$ denotes the slip velocity and x_1 is the projection of the material point along the x axis at time t_1 .

The receptors on the surface of the rolling cell are appropriately positioned for bond formation when they reach position x_1 :

$$x_1 = [2R_0(l_0 - y_0)]^{1/2}, \quad (\text{A3})$$

where l_0 is the optimum bond length and y_0 is the minimum microscale distance between the cell surface and the substrate surface (Fig. 2).

Geometric considerations show that the length l of a bond will deviate from its optimum length l_0 during rolling in accordance with the following equation

$$l^2 = l_0^2 + 2\Delta_y l_0 + \Delta_y^2 + \Delta_x^2, \quad (\text{A4})$$

where Δ_x and Δ_y are given by Eqs. A1 and 2.

The bond length l is composed of (a) the length of the receptor-counterreceptor complex (l_c) and (b) the local extension of the cell surface ($l - l_c$) in response to bond force. The parameter l_c is expressed as a function of bond length l by expressing the bond force in terms of both the bond stiffness (κ) and local cell stiffness (G):

$$f = \kappa(l_c - l_0) = G(l - l_c). \quad (\text{A5})$$

The components of the bond force in the direction of flow (f_x) and in the direction perpendicular to flow (f_y) are then obtained by combining Eq. 5 with Eqs. 1, 2, and 4 and noting that the unstressed bonds at location x_1 is assumed perpendicular to the substrate.

Steady State Binding of CD62 Neutrophils

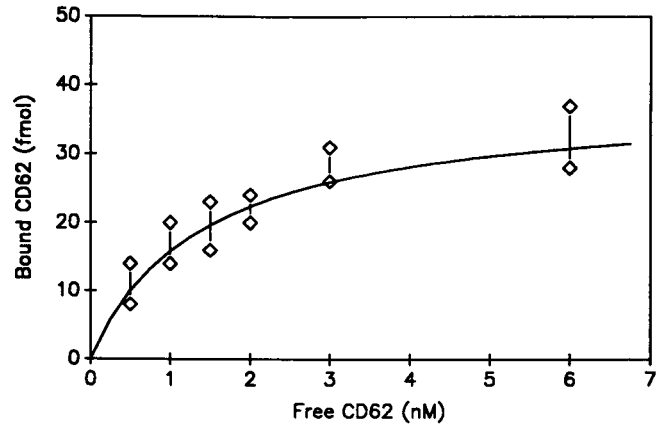

The Time Course of Labeled CD62 Binding to Neutrophils

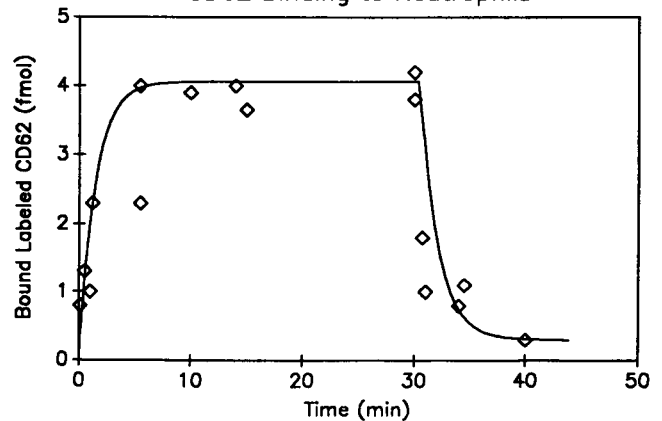

FIGURE 5 Steady-state binding of P-selectin to neutrophils (top) and the time course of [¹²⁵I]P-selectin binding and subsequent detachment to neutrophils (bottom). The experimental data by Moore et al. (1991) are shown with discrete points. The continuous lines in the graph depict the prediction of the bimolecular scheme. See Appendix for details.

Estimation of the biochemical constants of P-selectin-counterreceptor interaction

The data by Moore et al. (1991) on steady-state P-selectin binding (1 h incubation time) to neutrophils at 4°C is summarized in the top panel of Fig. 5 (discrete points). In these experiments, 10⁶ neutrophils were incubated with [¹²⁵I]P-selectin (0.1–0.2 nM) in the presence of increasing concentrations of unlabeled P-selectin for 1 h. The continuous lines in the same figure is the prediction of the bimolecular kinetic scheme with dissociation constant $K_d = 1.4$ nM.

Shown in the bottom panel of Fig. 5 are the experimental data (discrete points) obtained by Moore et al. (1991) on the time course of [¹²⁵I]CD62 binding (0.1–0.3 nM) to neutrophils (10⁶ cells) at 4°C and subsequent detachment due to the addition of hundredfold molar excess unlabeled P-selectin into the medium. Also shown in the same panel is the prediction of the bimolecular kinetics with $K_d = 1.4$ nM, [¹²⁵I]CD62 = 0.2 nM, the rate of bond detachment $k^- = 0.01$ s⁻¹, and the rate of bond formation $k^+ = 0.7 \times 10^7$ M⁻¹s⁻¹.

The rate constants of the membrane-bound interaction at optimum bond length (k_{mo}^+ , k_{mo}^-) were estimated from the values of k^+ and k^- by

using the method of Bell (1978). If one assumes that the minimum encounter distance for bond formation is 0.75 nm (Bell, 1978) and the self-diffusion coefficients of selectins or their counterreceptors (Abney et al., 1989) are $\sim 10^{-10}$ cm²/s, then $k_{\text{mo}}^- = 5 \times 10^{-4}$ s⁻¹, $k_{\text{mo}}^+ = 0.6 \mu\text{m}^2/\text{s}$.

Rate equation of bond formation

The bond formation during steady-state rolling is assumed to be governed by a bimolecular rate equation:

$$-V_o dn/dx = k_m^+(m_{10} - n)(m_{20} - n) - k_m^-, \quad (\text{A6})$$

where n ($1/\mu\text{m}^2$) denotes the surface density of bonds, dn/dx is the derivative of n with respect to x , and m_{10} and m_{20} are the site densities of surface receptors on the rolling cell and their counterreceptors on the vascular endothelium, respectively (Tözere et al., 1989). Note that the receptors that are positioned on the leukocyte in between surface projections cannot interact with their counterreceptors on the substrate and therefore do not contribute to m_{10} and m_{20} .

In the model, it was further assumed that (a) the attachment rate $k_m^+ = k_{\text{mo}}^+$ and the detachment rate $k_m^- = k_{\text{mo}}^-$ when bond length is less than or equal to the optimum bond length l_o and (b) $k_m^+ = 0$, $k_m^- = g$ when bond length is greater than the optimum bond length.

The differential Eq. A6 was solved by using the DIVPAG software package from IMSL Inc. Mathematics Library (Houston, TX). As the boundary condition, the surface bond density of bonds at the leading edge of conjugation ($x = x_1$) was set equal to zero.

The number of bonds between the cell and the substrate was computed by integrating n along the x axis, assuming that the effective width of the contact zone is equal to x_1 (see Eq. A3 for the definition of x_1). The resultant bond force on the rolling cell (F_{xb} , F_{yb}) and the bond moment with respect to the cell center (M_{zb}) were determined by integrating the surface density of bond force and bond moment along the x axis.

The predicted number of adhesion bonds in the contact area varies between 12 and 21 in the computational experiments shown in Fig. 3. Implicit in the model used here is the assumption that a large number of leukocyte surface receptors interact with their counterreceptors on the endothelium at any one instant. Recently, Chen and Hill (1988) used the deterministic approach, adopted here, and the Monte Carlo method to compute the average velocity of a vesicle moving along a microtubule and showed that the probability density distribution of adhesive interactions computed by the Monte Carlo method for 10 interacting molecules is not significantly different from that obtained by the deterministic approach.

Nonspecific repulsive force acting on the leukocyte

The resultant nonspecific repulsive force between the rolling cell and its substrate was evaluated by integrating the expression given by Bell et al. (1984) for the nonspecific repulsive force density along the spherical cell surface. In this expression, the repulsion intensity constant (γ) and the typical length of the nonspecific repulsion (ω) appear as input parameters.

Force balance on a cell near a planar wall in a shear flow

The fluid force (F_{xf} , F_{yf}) and the fluid moment (M_{zf}) acting on a spherical cell near a planar wall in simple shear flow can be computed from the tables in Goldman et al. (1967a, b) by assuming that (a) the cell rolls without slip, (b) cell radius (R_o) is equal to 3.5 μm , and (c) the gap thickness between the cell and the substrate ($\sim 0.12 \times R_o$) is approximately equal to the typical length of the leukocyte surface projections (H_o). When the angular speed is at least one order of magnitude smaller than the wall shear rate, as in the case of rolling adhesion of

leukocytes to vascular endothelium, the fluid force and the fluid moment acting on the cell are not sensitive to the value of the angular cell velocity. Under these conditions, following approximate equations can be derived for these parameters from the solution of Goldman et al. (1967b):

$$F_{xf} \cong 1.7(6\pi R_o^2 \tau) \quad (\text{A7a})$$

$$F_{yf} \cong 0 \quad (\text{A7b})$$

$$M_{zf} \cong -0.95(4\pi R_o^3 \tau), \quad (\text{A7c})$$

where $0.03 < H_o/R_o < 0.13$. For a shear stress of 1.6 dyn/cm², and $R_o = 3.5 \mu\text{m}$, $F_{xf} \cong 5 \times 10^{-6}$ dyn, and $M_{zf} = 7 \times 10^{-6}$ dyn- μm .

The method described above for determining the fluid force and the moment acting on a rolling leukocyte is valid for in vitro laminar flow assays where the substrate is a planar lipid-bilayer. In vivo, leukocytes do not roll on planar surfaces but on curved surfaces. The typical diameter of a blood vessel on which leukocytes roll is several times that of the cell diameter (Fig. 1), so that the consideration of the vascular endothelium as a planar substrate is a reasonable first approximation except, perhaps in postcapillary venules, where rolling is initiated (Schmid-Schönbein et al., 1980).

An optimization procedure for parameter evaluation

We used an optimization procedure (the subroutine DBCLSF from IMSL Inc. Mathematics Library) to compute y_o , V_s , and Ω_o such that the resultant force and moment on the rolling cell is equal to zero. The function to be minimized was chosen as:

$$W = (F_{yb} + F_{yr})^2/2 + (F_{xb} + F_{xf})^2/2 + (M_{zb} + M_{zf})^2/2. \quad (\text{A8})$$

In this optimization procedure, the output consists of the minimum value of W , the number of iterations required to achieve a solution, and the values of up to three parameters (y_o , V_s , Ω_o) that minimizes W for the prescribed values of the remaining parameters. A desired solution is assumed to be obtained when the minimum value of W becomes equal to zero (within 4 digits of accuracy). In the computations, bond parameters (k_{mo}^+ , k_{mo}^- , g , l_m , κ , and G), parameters of nonspecific repulsion (γ , ω), the fluid wall shear stress (τ), and the estimates of y_o , V_s , and V_o are supplied as input.

We are grateful to Professor Richard Skalak for useful discussions on the biophysics of leukocyte rolling.

This research was partially supported by National Institutes of Health grant GM-41460 and by Deutsche Forschungsgemeinschaft Le 573/3-1.

Received for publication 12 December 1991 and in final form 8 May 1992.

REFERENCES

- Abbassi, O., C. Lane, S. S. Krater, T. K. Kishimoto, D. C. Anderson, L. V. McIntire, and C. W. Smith. 1991. *J. Immunol.* 147:2107-2115.
- Abney, J. R., B. A. Scalettar, and J. C. Owicki. 1989. Self diffusion of interacting membrane proteins. *Biophys. J.* 55:817-833.
- Aruffo, A., W. Kolanus, G. Walz, P. Friedman, and B. Seed. 1991. CD62/P selectin recognition of myeloid and tumor cell sulfatides. *Cell* 35-44.
- Atherton, A., and G. V. R. Born. 1973. Relationship between the veloc-

- ity of rolling granulocytes and that of the blood flow in venules. *J. Physiol. (Lond.)*. 233:157-165.
- Beer, F. P., and E. R. Johnston. 1984. Dynamics, 4th ed. McGraw-Hill Inc., New York.
- Bell, G. I. 1978. Models for the specific adhesion of cells to cells. *Science (Wash. DC)*. 200:618-627.
- Bell, G. I., M. Dembo, and P. Bongrand. 1984. Competition between nonspecific repulsion and specific bonding. *Biophys. J.* 45:1051-1064.
- Bevilacqua, M. P., E. C. Butcher, B. Furie, et al. 1991. Selectins-a family of adhesion receptors. *Cell*. 67:223-233.
- Chen, Y. D., and T. L. Hill. 1988. Theoretical calculation methods for kinesin in fast axonal transport. *Proc. Natl. Acad. Sci. USA*. 85:431-435.
- Cohnheim, J. 1877. Vorlesungen über allgemeine Pathologie. August Hirschwald Verlag, Berlin.
- Dembo, M., D. C. Torney, K. Saxman, and D. Hammer. 1988. The reaction limited kinetics of membrane-to-surface adhesion and detachment. *Proc. R. Soc. Lond. B Biol. Sci.* 234:55-83.
- Elber, R., and M. Karplus. 1987. Multiple conformational states of proteins: a molecular dynamic analysis of myoglobin. *Science (Wash. DC)*. 235:318-322.
- Evans, E., D. Berk, and A. Leung. 1991. Detachment of agglutinin-bonded red blood cells: I. Forces to rupture molecular-point attachments. *Biophys. J.* 59:838-847.
- Fiebig, E., K. Ley, and K.-E. Arfors. 1991. Rapid leukocyte accumulation by spontaneous rolling and adhesion in the exteriorized rabbit mesentery. *Int. J. Microcirc. Clin. Exp.* 10:127-144.
- Firrell, J. C., and H. H. Lipowsky. 1989. Leukocyte margination and deformation in mesenteric venules of rat. *Am. J. Physiol.* 256:H1667-H1674.
- Fung, Y. C. 1984. Biomechanics. Springer-Verlag New York Inc., New York. 404 pp.
- Goldman, A. J., R. G. Cox, and H. Brenner. 1967a. Slow viscous motion of a sphere parallel to a plane wall. I motion through a quiescent fluid. *Chem. Eng. Sci.* 22:637-651.
- Goldman, A. J., R. G. Cox, and H. Brenner. 1967b. Slow viscous motion of a sphere parallel to a plane wall. II couette flow. *Chem. Eng. Sci.* 22:653-660.
- Johnston, G. I., R. G. Cook, and R. P. McEver. 1989. Cloning of GMP-140, a granule membrane protein of platelets and endothelium: sequence similarity to proteins involved in cell adhesion and inflammation. *Cell*. 56:1033-1044.
- Lawrence, M. B., and T. A. Springer. 1991. Leukocytes roll on selectin at physiologic flow rates: distinction from and prerequisite for adhesion through integrins. *Cell*. 65:859-873.
- Ley, K., and P. Gaetgens. 1991. Endothelial, not hemodynamic differences are responsible for preferential leukocyte rolling in venules. *Circ. Res.* 69:1034-1041.
- Ley, K., P. Gaetgens, C. Fennie, M. S. Singer, L. A. Lasky, and S. D. Rosen. 1991. Lectin-like cell adhesion molecule 1 mediates leukocyte rolling in mesenteric venules in vivo. *Blood*. 77:2553-2555.
- Lipowsky, H. H., S. Usami, and S. Chien. 1980. In vivo measurements of apparent viscosity and microvessel hematocrit in the mesentery of the cat. *Microvasc. Res.* 19:45-70.
- Marchesi, V. T. 1961. The site of leukocyte emigration during inflammation. *Q. J. Exp. Physiol.* 46:115-133.
- McEver, R. P. 1991. Leukocyte interactions mediated by selectins. *Thromb. Haemostasis*. 66:80-87.
- Moore, K. L., A. Varki, and R. P. McEver. 1991. GMP-140 binds to a glycoprotein receptor on human neutrophils: evidence for a lectin-like interaction. *J. Cell Biol.* 112:491-499.
- Pasternak, C., and E. Elson. 1985. Lymphocyte mechanical response triggered by crosslinking surface receptors. *J. Cell Biol.* 100:860-872.
- Picker, L. J., R. A. Warnock, A. R. Burns, C. M. Doerschuk, E. L. Berg, and E. C. Butcher. 1991. The neutrophil selectin LECAM-1 presents carbohydrate ligands to vascular selectins ELAM-1 and GMP-140. *Cell*. 66:921-933.
- Schmid-Schönbein, G. W. 1990. Leukocyte biophysics. *Cell Biophys.* 107-135.
- Schmid-Schönbein, G. W., S. Usami, R. Skalak, and S. Chien. 1980. The interaction of leukocytes and erythrocytes in capillary and post-capillary vessels. *Microvasc. Res.* 19:45-70.
- Springer, T. A. 1990. Adhesion receptors of the immune system. *Nature (Lond.)*. 346:425-434.
- Tözeren, A. 1990. Cell-cell conjugation: transient analysis and experimental implications. *Biophys. J.* 58:641-652.
- Tözeren, A., K. L. P. Sung, and S. Chien. 1989. Theoretical and experimental studies on cross bridge migration during cell diaggregation. *Biophys. J.* 55:479-487.
- von Andrian, U. H., J. D. Chambers, L. M. Mcenvey, R. F. Bargatze, K.-E. Arfors, and E. C. Butcher. 1991. Two step model of leukocyte-endothelial cell interaction in inflammation: distinct roles for LECAM-1 and leukocyte β_2 integrins in vivo. *Proc. Natl. Acad. Sci. USA*. 88:7538-7542.