

Haplogroup Effects and Recombination of Mitochondrial DNA: Novel Clues from the Analysis of Leber Hereditary Optic Neuropathy Pedigrees

Valerio Carelli,^{1,2} Alessandro Achilli,³ Maria Lucia Valentino,¹ Chiara Rengo,³ Ornella Semino,³ Maria Pala,³ Anna Olivieri,³ Marina Mattiazzi,¹ Francesco Pallotti,⁴ Franco Carrara,⁵ Massimo Zeviani,⁵ Vincenzo Leuzzi,⁶ Carla Carducci,⁷ Giorgio Valle,⁸ Barbara Simionati,⁸ Luana Mendieta,⁹ Solange Salomao,⁹ Rubens Belfort Jr.,⁹ Alfredo A. Sadun,² and Antonio Torroni³

¹Dipartimento di Scienze Neurologiche, Università di Bologna, Bologna; ²Doheny Eye Institute, Keck/University of Southern California School of Medicine, Los Angeles; ³Dipartimento di Genetica e Microbiologia, Università di Pavia, Pavia, Italy; ⁴Department of Neurology, College of Physicians and Surgeons, Columbia University, New York; ⁵Division of Molecular Neurogenetics, National Neurological Institute "Carlo Besta," Milan; Dipartimenti di ⁶Scienze Neurologiche e Psichiatriche dell' Età Evolutiva and ⁷Medicina Sperimentale, Università di Roma "La Sapienza," Rome; ⁸Centro Ricerca Interdipartimentale Biotecnologie Innovative, Università di Padova, Padua, Italy; and ⁹Departamento de Oftalmologia, Universidade Federal de São Paulo, São Paulo

The mitochondrial DNA (mtDNA) of 87 index cases with Leber hereditary optic neuropathy (LHON) sequentially diagnosed in Italy, including an extremely large Brazilian family of Italian maternal ancestry, was evaluated in detail. Only seven pairs and three triplets of identical haplotypes were observed, attesting that the large majority of the LHON mutations were due to independent mutational events. Assignment of the mutational events into haplogroups confirmed that J1 and J2 play a role in LHON expression but narrowed the association to the subclades J1c and J2b, thus suggesting that two specific combinations of amino acid changes in the cytochrome *b* are the cause of the mtDNA background effect and that this may occur at the level of the supercomplex formed by respiratory-chain complexes I and III. The families with identical haplotypes were genealogically reinvestigated, which led to the reconnection into extended pedigrees of three pairs of families, including the Brazilian family with its Italian counterpart. The sequencing of entire mtDNA samples from the reconnected families confirmed the genealogical reconstruction but showed that the Brazilian family was heteroplasmic at two control-region positions. The survey of the two sites in 12 of the Brazilian subjects revealed triplasmcy in most cases, but there was no evidence of the tetraplasmcy that would be expected in the case of mtDNA recombination.

In the past decade, haplogroups of the mitochondrial genome were extensively and successfully used as tools for investigating human origin and evolution (Macaulay et al. 2005). However, mtDNA is not only a string of DNA with peculiar features useful for evolutionary studies, but it also contains genes involved in the generation of cellular energy through the process of oxidative phosphorylation. Thus, the high mutation rate of the mitochondrial genome has resulted not only in the accumulation of the broad spectrum of sequence polymorphisms that distinguish haplogroups and subhaplogroups but also in a large number of disease-causing mutations. These diseases generally manifest in organs and tissues that rely heavily on mitochondrial energy production (Wallace 2005).

Leber hereditary optic neuropathy (LHON [MIM 535000]) was the first disease to be linked with an mtDNA point mutation (Wallace et al. 1988) and is characterized by a maternally inherited loss of central vision, which occurs most frequently in males. Three

mtDNA point mutations affecting the ND (NADH dehydrogenase) subunits of the respiratory enzyme complex I (11778/ND4, 3460/ND1, and 14484/ND6) are commonly found worldwide and are well established as pathogenic. However, other rare pathogenic mutations continue to be reported in a minority of families negative for the above-named common mutations, all involving complex I (for reviews, see Carelli et al. [2004] and Newman [2005]).

In addition to the search for disease-causing mutations, the sequence variation of the human mitochondrial genome has been the focus of numerous studies investigating its role as a contributing factor in the pathogenesis of neurodegenerative diseases (Howell et al. 2005; Wallace 2005). Indeed, it has been proposed that certain mtDNA polymorphisms, or combinations thereof, may confer a higher risk for certain complex diseases—in other words, that the supposedly “neutral” mutations that define haplogroups and subhaplogroups play a role in disease expression (Torroni and Wallace 1994). The

Received December 8, 2005; accepted for publication January 13, 2006; electronically published January 27, 2006.

Address for correspondence and reprints: Dr. Antonio Torroni, Dipartimento di Genetica e Microbiologia, Università di Pavia, Via Ferrara 1, 27100 Pavia, Italy. E-mail: torroni@ipvgen.unipv.it

Am. J. Hum. Genet. 2006;78:564–574. © 2006 by The American Society of Human Genetics. All rights reserved. 0002-9297/2006/7804-0005\$15.00

first strong evidence of such a haplogroup effect was reported in 1997, again the result of studying LHON. Four concomitant investigations performed on patients of diverse European origins revealed that the LHON mutations 11778/ND4 and 14484/ND6 were preferentially associated with the western Eurasian haplogroup J (Brown et al. 1997; Hofmann et al. 1997; Lamminen et al. 1997; Torroni et al. 1997). This observation led to the idea that the mutational motif in ND subunits that defines haplogroup J—4216C/ND1-10398G/ND3-13708A/ND5—might increase the penetrance of the 11778/ND4 and 14484/ND6 mutations and the risk of disease expression (Torroni et al. 1997).

After these findings about LHON, association studies with haplogroups became a common approach to unravel the role of mtDNA-sequence variation in various disorders and phenotypes, and the number of studies has grown exponentially. For example, haplogroup J has also been associated with successful aging (De Benedictis et al. 1999; Ross et al. 2001; Niemi et al. 2003), and associations have been reported between haplogroup U and occipital stroke in migraine (Majamaa et al. 1998), haplogroup J and optic neuritis (Reynier et al. 1999), haplogroup T and asthenozoospermia (Ruiz-Pesini et al. 2000), haplogroup H and both migraine without aura and cyclic vomiting syndrome (Wang et al. 2004), haplogroup D4h and bipolar disorder (Munakata et al. 2004), and haplogroups J2 and K and sprint athletic performances (Niemi and Majamaa 2005). However, except for LHON, virtually all reported associations between haplogroups and diseases have remained provisional. The findings of one study have rarely been replicated by studies of other populations, and conflicting associations have been often reported. One striking example of inconsistency is highlighted by the recent studies of Parkinson disease (PD). It has been proposed that a reduced risk of PD for Europeans is associated with haplogroups J and K (van der Walt et al. 2003), the supercluster UKJT (Pyle et al. 2005), or haplogroup K alone (Ghezzi et al. 2005), whereas other studies suggested an increased risk with either the superhaplogroup JT (Ross et al. 2003) or the supercluster JTIWX (Autere et al. 2004).

Association studies can be confounded if patients and controls are not well matched. However, mtDNA association studies are probably also affected by another major specific problem: the resolution of the mtDNA haplogroup structure is generally low. A recent study confirms that mtDNA association analyses performed so far have been too simplistic (Achilli et al. 2004). It showed that haplogroup H—by far the most common haplogroup in Europe, with a uniformly high frequency (30%–50%)—is divided into numerous subhaplogroups whose frequency is very different in European regions. Such differential frequency distributions alone could eas-

ily explain some of the inconsistent results obtained by association studies performed on different European populations.

In the past few years, some studies have raised doubts even about what was considered the strongest of the associations, that between LHON and haplogroup J. A survey of Iranian patients with LHON did not detect such an association (Houshmand et al. 2004), and a rather large number of Dutch, French, and French-Canadian LHON-affected families harboring the 14484/ND6 mutation were found to share a haplotype characterized by the rare motif 3394A-16213A (Macmillan et al. 2000; Howell et al. 2003; Laberge et al. 2005). This observation revealed a founder event that might have occurred 900–1,800 years ago (Howell et al. 2003). The discovery of this founder event in western Europe, although confirming that haplotype analysis is a powerful tool to reconnect apparently unrelated LHON-affected families into extended pedigrees, raises the possibility that at least part of the preferential association between haplogroup J and the mutations 14484/ND6 and 11778/ND4 observed in Europeans might be explained by founder events rather than by an effect of the mtDNA background.

Another controversial issue in human mitochondrial genomics, with major implications for molecular and evolutionary studies, is whether mtDNA undergoes recombination. Experimental evidence of mtDNA recombination in humans was recently obtained for the only subject reported with biparental inheritance of mtDNA (Kraytsberg et al. 2004), in an *in vitro* cell-culture system (D'Aurelio et al. 2004), and in the skeletal muscle of individuals with multiple mtDNA heteroplasmy (Zsurka et al. 2005). However, no studies have evaluated the possibility of mtDNA recombination by studying human pedigrees, which are probably the most informative biological context for investigation of this issue.

The present study, which was performed on mtDNAs from 86 Italian index subjects with LHON and one Brazilian family of maternal Italian ancestry, is aimed at clarifying the impact of founder effects on the association of the LHON mutations 11778/ND4 and 14484/ND6 with haplogroup J, as opposed to the previously hypothesized functional effect of the mtDNA background (Man et al. 2004). We also investigated, by dissecting haplogroup J into subclades, whether the association with LHON mutations was restricted to subsets of J characterized by differential ethnic/geographic distributions and peculiar arrays of nonsynonymous polymorphisms with the potential for a functional effect. Finally, we performed a genealogical reconnection into extended pedigrees of some LHON-affected families harboring haplotype identities. Two heteroplasmic nucleotide substitutions that occurred in one extended pedigree were evaluated to detect mtDNA recombination.

Subjects and Methods

LHON Samples

The study was performed on the mtDNA of 86 Italian index cases with LHON who harbored a known causative LHON mutation (66 subjects with 11778/ND4, 13 subjects with 3460/ND1, 6 subjects with 14484/ND6, and 1 subject with 14482A/ND6) and who were sequentially identified in three Italian diagnostic centers (Dipartimento di Scienze Neurologiche, Università di Bologna, Bologna; Istituto Neurologico Nazionale “Carlo Besta,” Milan; and Policlinico Università “La Sapienza,” Rome). An additional Brazilian family of Italian maternal ancestry with the LHON 11778/ND4 mutation (SOA-BR) (Sadun et al. 2003) was also included in the study. The control group consisted of 2,071 unrelated Italians. Appropriate informed consent was obtained from all subjects.

Analysis of mtDNA-Sequence Variation

Genomic DNA was extracted from blood by standard procedures. High-resolution RFLP analysis of mtDNA was then performed and was accompanied, as reported elsewhere (Torroni et al. 2003), by sequencing 740–820 nt of the mtDNA control region, beginning at nucleotide position (np) 16000. This allowed the construction of high-resolution haplotypes and the identification of diagnostic haplogroup markers. For haplogroup and subhaplogroup affiliation of both patient and control mtDNA samples, the most-recent phylogenetic data on western Eurasian haplogroups and subhaplogroups were taken into account (Achilli et al. 2004, 2005; Palanichamy et al. 2004; Kivisild et al. 2005), and, whenever necessary, both control and LHON mtDNA samples were screened for additional diagnostic markers. Sequencing of entire mtDNA samples and phylogeny construction were performed as described elsewhere (Torroni et al. 2001; Achilli et al. 2004).

Quantification of Heteroplasmy

The level of heteroplasmy at np 16092 and np 16129 in 17 mtDNA samples from the reconnected LB10 and BSL07 families was evaluated by using the forward primer 16060–16090 with the mismatch position 16088A, which introduces an *ScaI* restriction site in the presence of 16092C, and the reverse primer 16260–16280. The 16129A mutation introduces a *Bsp1407I* restriction site, and it can be recognized on the same amplicon as 16092C. The quantification of heteroplasmy was performed by densitometry on gel photographs by use of the Fluor-S MAX Multimager System (Biorad).

Statistics

Statistical analyses were performed using the SPSS statistical package, version 12.0, and statistical significance was established at $\alpha = 0.05$. Binary logistic-regression analysis was used to assess the association between haplogroups and LHON. Because haplogroup affiliation is a categorical independent variable with more than two categories, we performed a logistic regression of all haplogroup categories at one time (to look for any effect), using haplogroup H* as a reference level. Because the categories U* and “others” were absent among subjects with LHON, those categories were aggregated with L1b.

The distribution of LHON mutations on J1 and J2 and their subclades was evaluated using the Fisher’s exact test.

Results

Haplotype Analysis of mtDNA from Probands with LHON

High-resolution RFLP analysis and control-region sequencing revealed that, among the 67 mtDNA samples with the 11778/ND4 mutation, there were 55 different haplotypes (6 double- and 3 triple-haplotype identities, including the Brazilian proband); among the 13 mtDNA samples carrying the 3460/ND1 mutation, there were 12 different haplotypes (only 1 pair with an identical haplotype), and the 6 mtDNA samples carrying the 14484/ND6 mutation fell into 6 different haplotypes (table 1). Note that none of the Italian 14484/ND6 haplotypes harbored the distinguishing 3394A-16213A motif associated with the 14484/ND6 Dutch/French founder event described above.

This haplotype distribution strongly suggests 74 independent mutational events among the 87 LHON-affected families: 55 occurrences of the 11778/ND4 mutation, 12 occurrences of the 3460/ND1 mutation, 6 occurrences of the 14484/ND6 mutation, and 1 occurrence of the 14482A/ND6 mutation (Valentino et al. 2002). Indeed, even those mtDNAs with the same LHON mutation that were members of the same haplogroup/subhaplogroup—and thus could theoretically harbor the LHON mutation by descent—generally differed by several mutations in both the coding and the control regions (table 1). Moreover, many of their different control-region motifs have been observed in a random sample of 2,071 mtDNA samples from the general Italian population, which is further support of the independence of the LHON mutational events. On the other hand, with the same rationale, pairs and triplets of identical haplotypes most likely represent pedigrees that are only apparently unrelated but that, in reality, acquired the LHON mutation by descent from a common female ancestor. However, we cannot completely exclude the possibility that the same LHON mutation might have occurred twice on mtDNA samples with the same haplotypes, even though the probability would, in general, be very low.

Table 1

RFLP and Control-Region mtDNA Haplotypes from 1 Brazilian and 86 Italian Probands with LHON

The table is available in its entirety in the online edition of *The American Journal of Human Genetics*.

Distribution of LHON Mutational Events into Haplogroups

The next step in the study was to evaluate the distribution of the 74 plausible LHON mutational events into haplogroups and subhaplogroups. This distribution is illustrated in table 2. The frequency values were compared with the haplogroup frequencies observed in a sample of 2,071 unrelated Italian controls.

A binary logistic regression was performed on the data shown in table 2, to first assess the risk of mtDNA haplogroups with LHON (all mutations pooled). In the logistic regression, we evaluated the likelihood of the entire model by the *P* value associated with the likelihood-ratio test (the null hypothesis is that all slopes are equal to zero) and found a significant *P* value of .019, which indicates that at least one predictor (haplogroup) is significantly associated with the response. Among the predictors, only haplogroups J1 and J2 were found to significantly affect the risk of LHON, with odds ratios (ORs) indicating an increased risk (for J1, OR = 3.36, 95%

CI 1.60–7.08, *P* = .001; for J2, OR = 3.94, 95% CI 1.24–12.54, *P* = .020). To confirm that these haplogroups were the only ones affecting LHON expression, we repeated the logistic-regression model excluding haplogroups J1 and J2. In that case, the likelihood-ratio test showed a *P* value of .558, which confirms the absence of significant associations with other haplogroups.

We then evaluated whether either haplogroup J1 or haplogroup J2 was differentially associated with the three most-common primary LHON mutations by using a two-tailed Fisher's exact test (table 3). A significant association was observed between the 11778/ND4 mutation and both haplogroups J1 and J2 and between the 14484/ND6 mutation and haplogroup J1. However, haplogroups J1 and J2 are made up of well-defined subclades: J1b, J1c, and J1d for J1 (the last is newly defined in this study; see below) and J2a and J2b for J2. Thus, we determined the distribution of these clades in both patients and controls (table 4). In the case of the 14484/ND6 mutation, the J1 subclades were represented, at

Table 2

Haplogroup Distribution of LHON Mutational Events in Italian Patients with LHON Relative to Italian Control Individuals

HAPLOGROUP	NO. (%) OF LHON MUTATIONAL EVENTS					
	Patients					Control Individuals (<i>n</i> = 2,071)
	11778 (<i>n</i> = 55)	3460 (<i>n</i> = 12)	14484 (<i>n</i> = 6)	14482A (<i>n</i> = 1)	Total (<i>n</i> = 74)	
H*	12 (21.8)	4 (33.3)	16 (21.6)	454 (21.9)
H1	2 (3.6)	1 (8.3)	3 (4.1)	216 (10.4)
H3	2 (3.6)	2 (2.7)	57 (2.8)
H5	1 (1.8)	1 (1.4)	109 (5.3)
V	...	1 (8.3)	1 (1.4)	66 (3.2)
pre*V	2 (3.6)	2 (2.7)	25 (1.2)
HV	3 (5.5)	3 (4.1)	71 (3.4)
pre-HV	1 (1.8)	1 (1.4)	15 (.7)
J1	9 (16.4)	...	4 (66.7)	1 (100.0)	14 (18.9)	119 (5.7)
J2	4 (7.3)	4 (5.4)	29 (1.4)
T1	2 (3.6)	1 (8.3)	4 (5.4)	50 (2.4)
T2	2 (3.6)	...	1 (16.7)	...	2 (2.7)	181 (8.7)
U*	34 (1.6)
U1	...	1 (8.3)	1 (1.4)	23 (1.1)
U2e	1 (1.8)	1 (1.4)	18 (.9)
U3	...	1 (8.3)	1 (1.4)	54 (2.6)
U4	...	1 (8.3)	1 (1.4)	41 (2.0)
U5a	1 (1.8)	1 (1.4)	72 (3.5)
U5b	2 (3.6)	2 (2.7)	47 (2.3)
U6	2 (3.6)	2 (2.7)	12 (.6)
K	5 (9.1)	5 (6.8)	154 (7.4)
I	1 (1.8)	1 (1.4)	40 (1.9)
N1b	1 (1.8)	1 (1.4)	20 (1.0)
W	1 (1.8)	1 (8.3)	2 (2.7)	38 (1.8)
X	...	1 (8.3)	1 (16.7)	...	2 (2.7)	68 (3.3)
L1b	1 (1.8)	1 (1.4)	2 (.1)
Others	56 (2.7)

^a H* includes H mtDNAs except those that belong to the subhaplogroups H1, H3, and H5.

^b U* includes mtDNAs that belong to the subhaplogroups U7, U8, and U9.

Table 3**Probability of Association between Haplogroups J1 and J2 and Primary LHON Mutations**

HAPLOGROUP	PROBABILITY (P) OF ASSOCIATION WITH LHON MUTATION		
	11778	3460	14484
J1	.003	.638	<.001
J2	.006	1.000	1.000

NOTE.—P values were obtained using Fisher's exact test (two-tailed). The frequencies of haplogroups J1 and J2 for subjects with LHON (subdivided according to LHON mutation) were compared with those of haplogroups J1 and J2 of Italian controls. In the comparisons, all non-J haplogroups were pooled together.

most, by two subjects, thus too few to evaluate a possible accumulation on a specific J1 subset. In contrast, the distribution of the 11778/ND4 mutation provides some new interesting clues. The excess of this mutation in J1 and J2 appears to be caused exclusively by an excess of J1c and J2b (Fisher's $P = .012$ and $P = .016$, respectively).

Reconnection of Nuclear LHON-Affected Families into Extended Pedigrees

Once it was determined that the association between haplogroup J and the 11778/ND4 and 14484/ND6 mutations in the Italian population with LHON is not even partially due to a founder event but is due to an effect of the mtDNA background, we focused on the seven double and three triple-haplotype identities found among the probands (table 1), in an effort to reconstruct their maternal relationships. On the basis of the genealogical reinvestigation of these families, two double haplotype identities (LB79/LB80 and LB02/LB76) (table 1) were immediately discarded because the index cases were indeed members of the same family but had received independent diagnoses in different centers. In the remaining eight cases of haplotype identities, by searching city-council and church records of birth certificates, we were able to formally reconnect six pedigrees into three pairs: BL04

and LB68 (fig. 1A), LB105 and BL02 (fig. 1B), and LB10 and the Brazilian BSL07 (fig. 2). Interestingly, the pair BL04 and LB68 is reconnected into a pedigree in which the 3460/ND1 mutation is still heteroplasmic in both family branches (fig. 1A). For the remaining haplotype identities, we could not formally certify that they belonged to the same maternal lineage. However, in all cases, the close geographical origin of the families strongly suggests a shared female ancestry.

Complete Sequencing of mtDNA Samples from Reconnected Pedigrees

To further evaluate the molecular identity of the three reconnected pairs, the six mtDNA samples were completely sequenced with some control samples. The phylogenetic tree in figure 3 illustrates the mutations relative to the revised Cambridge reference sequence (rCRS) (Andrews et al. 1999) and their haplogroup affiliations. The BL04 and LB68 mtDNA samples were identical and were found to harbor the mutations 3936/ND1 and 14552/ND6, which are typical of subhaplogroup H12 (Achilli et al. 2004). Also, the LB105 and BL02 mtDNA samples were identical and belong to subhaplogroup J1c (Palanichamy et al. 2004). In contrast, the mtDNA of Italian proband LB10 and Brazilian proband BSL07 were members of the same subset of J1, newly defined here as "J1d," but they were not identical. Relative to the rCRS, BSL07 harbored the two control-region transitions 16092C and 16129A, both in the heteroplasmic state, whereas, in LB10, 16092C was homoplasmic and 16129A was absent. This indicates that the most recent common female ancestor of the extended Italian/Brazilian pedigree (I-1 in fig. 2) harbored 16092C in either the homoplasmic or heteroplasmic state, whereas the 16129A mutation might have occurred later in the Brazilian branch. To further investigate the status at these two positions, we sequenced the mtDNA control region in 12 maternal relatives from the SOA-BR family (4 from generation III and 8 from generations V and VI, all belonging to distant branches of the genealogy) and in 5

Table 4**Frequencies of the J Subclades in Italian Patients with LHON and Control Individuals**

J SUBCLADES	NO. (%) OF PATIENTS WITH LHON WITH MUTATION					NO. (%) OF CONTROL INDIVIDUALS (n = 2,071)
	11778 (n = 55)	3460 (n = 12)	14484 (n = 6)	14482A (n = 1)	Total (n = 74)	
J1:						
J1b	1 (1.8)	...	1 (16.7)	...	2 (2.7)	24 (1.2)
J1c	7 (12.7)	...	2 (33.3)	1 (100.0)	10 (13.5)	92 (4.4)
J1d	1 (1.8)	...	1 (16.7)	...	2 (2.7)	3 (.1)
J2:						
J2a	1 (1.8)	1 (1.4)	11 (.5)
J2b	3 (5.5)	3 (4.1)	18 (.9)

available maternal relatives of the Italian branch (table 5). All other control-region positions were found to be invariant, but the differences at np 16092 and np 16129 were confirmed. All individuals from the Italian branch were homoplasmic for 16092C and lacked the mutation 16129A, as was already seen in proband LB10. In contrast, the investigation of the 12 maternal relatives from SOA-BR, including the proband BSL07, revealed, as indicated by the RFLP quantification, a wide variability in the degree of heteroplasmy at both positions in all subjects except one (V-132), who lacked 16129A.

Discussion

The Role of mtDNA Backgrounds in LHON Expression

Our survey of a very large number of independent LHON mutational events in Italian index cases confirms that the 11778/ND4 and 14484/ND6 mutations are preferentially associated with haplogroup J, whereas the 3460 mutation is distributed randomly among all mtDNA haplogroups. Is this new? The answer is no. This has been known for several years. However, what is new is that now we know that association studies of haplogroups, such as J, that are ancient and deeply rooted in the world mtDNA phylogeny, might easily miss significant differences between patients and controls because of the presence of multiple subclades, with different geographical and ethnical distributions, of which perhaps only one or a few play a role in disease expression. In the present study, we addressed this issue. We first performed the analysis at the level of subhaplogroups J1 and J2, observing a significant association between the 11778/ND4 mutation and both haplogroups J1 and J2 and between the 14484/ND6 mutation and haplogroup J1. Then, we tried to determine whether the haplogroup association could be narrowed further at the subclade level. We defined a novel subclade of J, which we named “J1d”; thus, all J mtDNA now falls into known subclades: J1b, J1c, and J1d for J1 and J2a and J2b for J2. Unfortunately, when subclades are analyzed, the problem of sufficient sample sizes becomes increasingly acute, even for analysis of a relatively large number of patients. In the case of the 14484/ND6 mutation, the J1 subclades encompassed too few subjects to evaluate a possible accumulation on a specific J1 subset. However, the distribution of the much more common 11778/ND4 mutation revealed that the excess of this mutation in J1 mtDNA and J2 mtDNA is due exclusively to an excess of J1c and J2b, respectively.

What is peculiar at the level of the mtDNA sequence in J1c and J2b? To answer this question, we evaluated the complete mtDNA sequences of the different J subclades. In addition to the nonsynonymous ND mutations at np 4216, np 10398, and np 13708, all J mtDNAs are

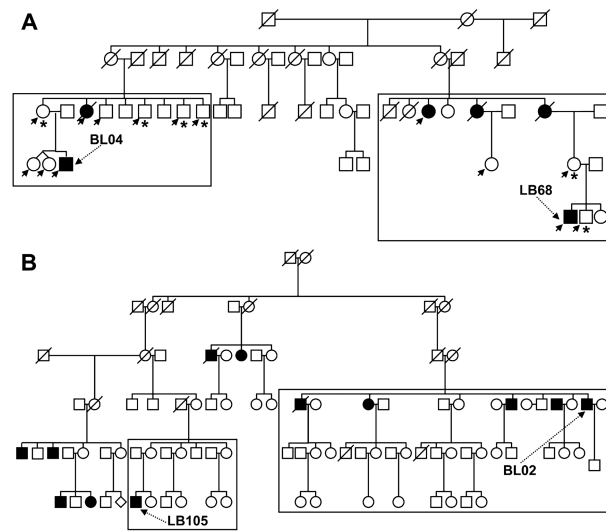

Figure 1 Two of the extended pedigrees, after the reconnection of apparently unrelated familial groups. *A*, The relationship between the BL04 (Carelli et al. 1997; Lodi et al. 2002) and LB68 pedigrees. These pedigrees are from the same Italian region (Emilia). Both probands, indicated by the dotted arrows, suffered typical LHON, with severe visual loss in their twenties; their mtDNAs were homoplasmic for the 3460/ND1 mutation on an identical H haplotype (table 1). An excess of affected females (4:2) is apparent, and all available affected subjects (4 of 6) harbored only homoplasmic mutant mtDNA. In contrast, the survey of available unaffected maternally related individuals showed that the 3460 mutation was heteroplasmic in multiple subjects from both families. Arrows indicate the subjects available for DNA testing of the 3460 mutation; an asterisk (*) indicates heteroplasmy, whereas the absence of the asterisk indicates homoplasmy. The results of the DNA testing suggest that the risk of developing LHON increases consistently only when the mutant mtDNA shifts to homoplasmy and partially explains the unusual prevalence of affected females in the BL04/LB68 extended family. *B*, The reconstructed 6-generation pedigree generated from the families LB105 (Vergani et al. 1995; Carelli et al. 1997; Lodi et al. 2000) and BL02, both also originating from the same geographical area (Abruzzo). All available subjects along the maternal line in both families were homoplasmic for the 11778/ND4 mutation. The male:female ratio (9:3) in the extended family matches the reported values for the 11778/ND4 mutation (Carelli et al. 2004).

characterized by a C→A transversion at np 15452 (fig. 3) that changes a nonconserved leucine to an isoleucine at position 236 of cytochrome b (*cyt b*)—the only mitochondrial subunit of complex III. Furthermore, J1c mtDNA harbors a second change in *cyt b*: a T→C transition at np 14798 that causes the substitution of a nonconserved phenylalanine with a leucine at position 19. J1b and J1d lack additional amino acid changes in *cyt b*. J2 also carries a second amino acid change in *cyt b*—a highly conserved aspartic acid to an asparagine at position 171—that is due to the G→A transition at np 15257. However, only J2b is additionally characterized by a third change in *cyt b*—a valine-to-methionine change at position 356—that is due to the G→A tran-

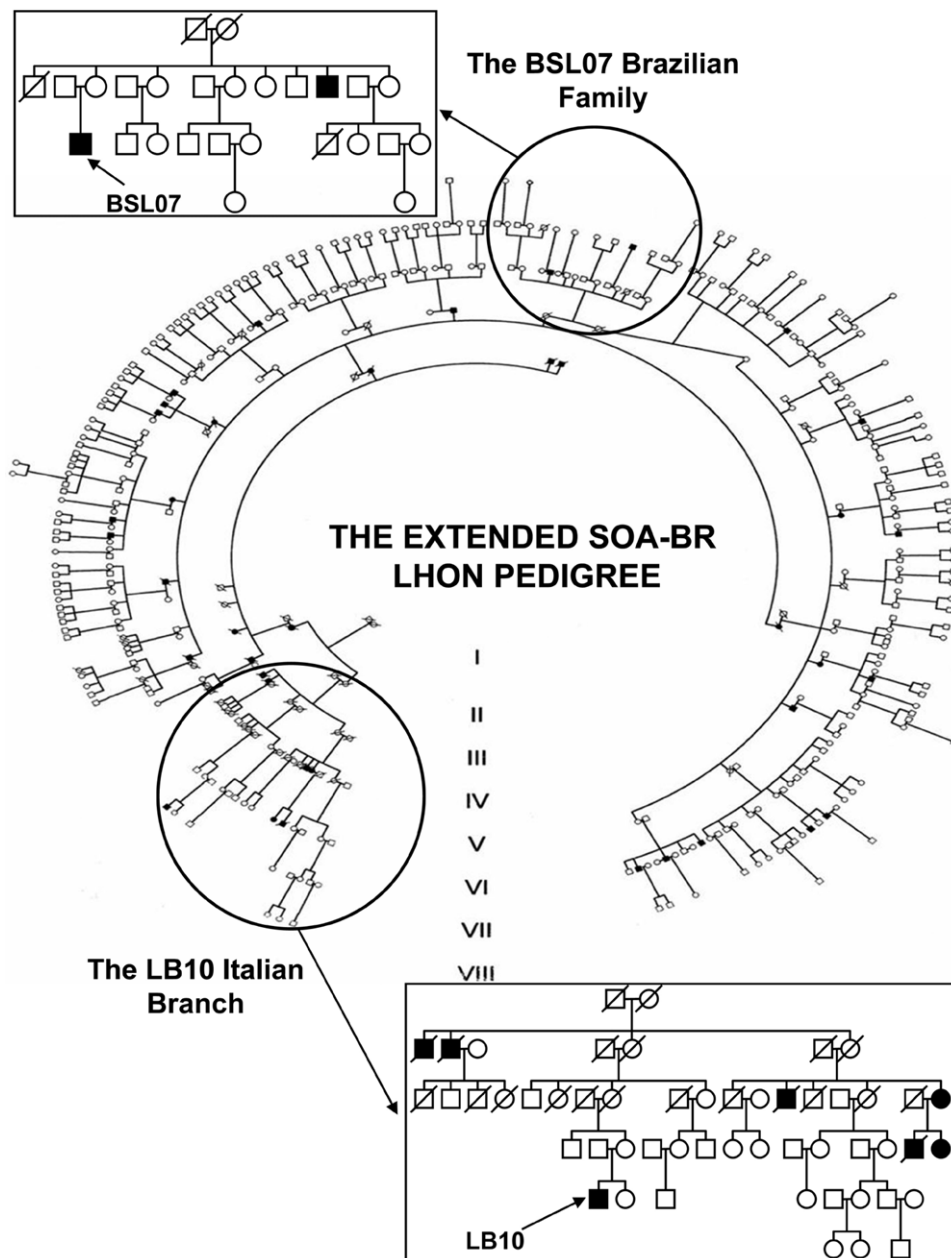

Figure 2 The reconstructed pedigree generated from families BSL07 and LB10. The BSL07 family originates from the state of Espírito Santo in Brazil and is a nuclear subset of the large Brazilian SOA-BR pedigree, which has been completely reconstructed and investigated from a genetic, epidemiological, and clinical point of view (Sadun et al. 2003, 2004; Salomao et al. 2004). Briefly, the SOA-BR family numbers ~360 family members, 128 of whom are maternally related. Of the latter, 35 are affected (23 are alive, 2 of whom are recent cases and became affected in the past 2 years). All 122 individuals investigated are homoplasmic for the 11778/ND4 mutation. The woman—daughter of the most recent common female ancestor of the entire pedigree, who migrated to Brazil and gave rise to the Brazilian branch—was born in 1861 in the Veneto region of northern Italy, the same geographical area from which the LB10 family originates.

sition at np 15812. In brief, J1c, the subclade preferentially associated with the 11778/ND4 mutation and the most common of the J1 subclades in Italy (~77% of J1 mtDNA), is characterized by two amino acid changes (L236I-F19L) in *cyt b*. J2b, the other subclade of J for which there is an excess of patients with the 11778/ND4

mutation, harbors three amino acid changes (L236I-D171N-V356M) in *cyt b*. Could this accumulation of *cyt b* amino acid changes be due to chance? Obviously, we cannot exclude the possibility. However, those nucleotide positions are very stable, with only a single recurrence (in haplogroup K) reported for the T→C transition at np

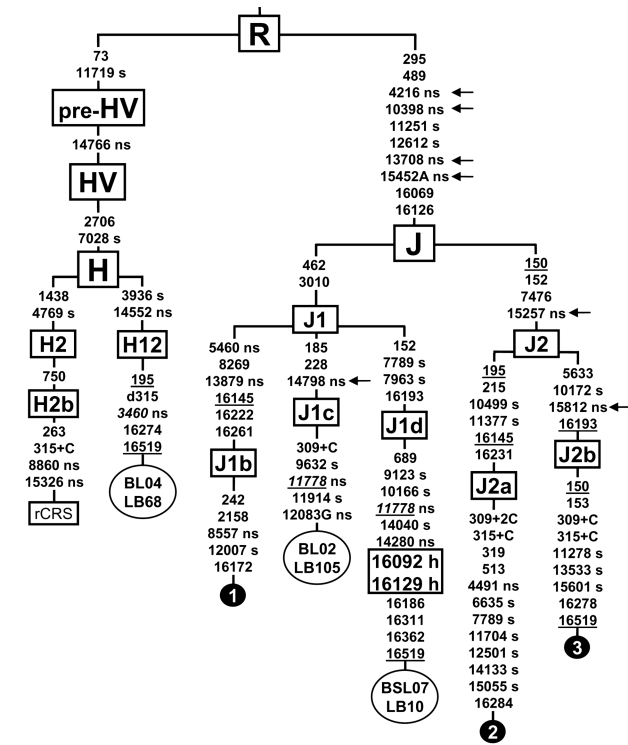

Figure 3 Tree encompassing the complete mtDNA sequences (GenBank) observed in the three pairs of reconnected LHON-affected families—BL04 and LB68 (haplogroup H12), LB105 and BL02 (haplogroup J1c), BSL07 and LB10 (haplogroup J1d)—together with those of mtDNAs that are representative of all other subclades of J. Sequences 2 (J2a) and 3 (J2b) are new and from Italian control individuals, whereas sequence 1 (J1b) corresponds to B30 (Palanichamy et al. 2004). The tree is rooted using the reference sequence rCRS (Andrews et al. 1999)—a member of haplogroup H2b—as an outgroup. Mutations are shown on the branches; they are transitions unless the base change is explicitly indicated. Insertions are suffixed with a plus sign (+) and the inserted nucleotide, and deletions have a “d” prefix. Heteroplasmic positions (*boxed*) in BSL07 are indicated by an “h” following the nucleotide position. In LB10, 16092C was homoplasmic and 16129A was absent. Underlining indicates recurrent mutations; “s” indicates synonymous mutations, whereas “ns” indicates nonsynonymous mutations. The arrows indicate the nonsynonymous J polymorphisms that might have a role in modulation of LHON expression. LHON mutations are shown in italics and were added to the tree after phylogeny construction.

14798 (Kivisild et al. 2005). Furthermore, the recent finding of a stable mitochondrial supercomplex that consists of complex I and dimeric complex III (Acin-Perez et al. 2004; Dudkina et al. 2005) raises the possibility that amino acid changes in the two complexes might directly interact with each other and influence the functional effect of the 11778/ND4 mutation and possibly also that of the 14484/ND6 mutation.

Finally, the observation that the excess of haplogroup J in patients with the 11778/ND4 mutation in Italy, and most likely in western Europe, might be largely attrib-

uted to J1c also explains the lack of association of LHON with haplogroup J in Iran (Houshmand et al. 2004), despite the fact that the frequency of J in that region is similar to that reported for European populations. The study by Quintana-Murci et al. (2004) reports a J frequency of ~8% in western Asia (48 J1 and 8 J2 mtDNAs in 702 subjects), but the control-region motifs of these mtDNAs reveal that the Asian J1 mtDNAs belong mainly to J1b (37 of 48; 77.0%), a result in sharp contrast to the frequency of the J1 subclades in Italy (and Europe), where J1b is much less common (24 of 119; 20.2%) and J1c is, by far, the most represented. Thus, the Iranian data can be easily explained, since the J subclades are differently distributed in western Eurasia, and represent a paradigmatic example of the need to improve the level of resolution of mtDNA haplogroups used in association studies.

Heteroplasmy at Two Nucleotide Positions in the Extended Italian/Brazilian Pedigree

The finding that all individuals from the Italian LB10 family were homoplasmic for 16092C and lacked the mutation 16129A but that their 12 maternal relatives from the Brazilian branch harbored a wide variability in the degree of heteroplasmy at both positions implies that 16092C was already present, in either the homoplasmic or heteroplasmic state, in the most recent female ancestor of the Italian and Brazilian branches. In the first scenario, this site mutated to a T in one of her very early Brazilian descendants (her daughter or granddaughter) and remained heteroplasmic in the SOA-BR pedigree. Alternatively, 16092 was already heteroplasmic in subject I-1 (fig. 2) and was fixed as a C in the Italian branch only. Nucleotide position 16129 could also have been heteroplasmic in I-1 and lost the 16129A form only in the Italian branch. However, this mutation also might have occurred more recently in one of her very early Brazilian descendants. Note that neither 16092C nor 16129A has been observed in any of the 119 mtDNAs belonging to the J1 haplogroup present in the 2,071 Italian controls. In any case, all but one of the Brazilian subjects harbor both 16092 and 16129 in the heteroplasmic state, which suggests that such a condition is generalized to the entire extended SOA-BR family. The presence of two alternative forms at two nucleotide positions raises the question of the numbers of different mtDNA molecules coexisting in the Brazilian subjects. The heteroplasmy quantification reported in table 5 pro-

Table 5

Control-Region Variation of mtDNAs from the Extended Italian/Brazilian Pedigree

The table is available in its entirety in the online edition of *The American Journal of Human Genetics*.

vides some clues on this issue. We noted that the amount of heteroplasmy is very different in the family members, without any constant ratio (a constant ratio would be suggestive of an association in *cis* between 16092C and 16129A), and that the sum of the percentages of 16092C and 16129A sometimes reaches almost 100%, although it is generally much less than that. Overall, this indicates that there is a condition of triplasmcy with a population of rCRS-like mtDNAs (16092T-16129G) that do not harbor either 16092C or 16129A and two *trans* populations, one with only 16092C (16092C-16129G) and the other with only 16129A (16092T-16129A), in most of the Brazilian subjects. Most importantly, there is no evidence of a fourth mtDNA species (tetraplasmy) in which 16092C and 16129A are in *cis* on the same molecule. The existence of such a species will become evident by detection of at least one subject in whom the sum of the percentages of 16092C and 16129A is >100%. Obviously, such a species is expected only if there is recombination between mtDNA molecules (D'Aurelio et al. 2004; Kraysberg et al. 2004; Zsurka et al. 2005), in particular between the *trans* species 16092C-16129G and 16092T-16129A. Our survey did not detect such a subject in the SOA-BR pedigree and thus does not support, at least for the moment, the existence of in vivo mtDNA recombination. Obviously, we cannot rule out the possibility either, especially taking into account that 16092 and 16129 are only 37 nps apart (Zsurka et al. 2005); thus, they are not very likely to be involved in a recombination event, even if recombination could occur. In any case, the SOA-BR extended pedigree is an ideal candidate for in-depth investigation of not only the issue of mtDNA recombination but also its potential role in generating mtDNA-sequence variation that might be transmissible in the germline through the generations.

In conclusion, this study reveals that the large majority of the LHON mutations in affected Italian families are due to independent mutational events, thus confirming that the preferential association of the LHON mutations 11778/ND4 with haplogroups J1 and J2 and 14484/ND6 with haplogroup J1 is attributable not to founder events but to a true mtDNA background effect. In the case of the 11778/ND4 mutation, such a role of the mtDNA background was narrowed to the subclades J1c and J2b, which both, intriguingly, harbor unique combinations of amino acid changes in *cyt b*. This finding raises the possibility that the LHON 11778/ND4 mutation, when occurring on either a J1c or J2b mtDNA, increases the risk of disease expression because it more easily affects some functional parameter of the mitochondrial supercomplex formed by respiratory-chain complexes I and III. Finally, we also identified eight haplotype identities that were suggestive of founder events. The combined use of haplotype data, city-council and church birth-certificate records, and the sequencing of

entire mtDNAs allowed the reconnection into extended pedigrees of families that were not known to be related, the extended Italian/Brazilian SOA-BR family being the most remarkable example. Studies of these large pedigrees offer multiple and powerful opportunities for investigation, including the possibility of detecting in vivo mtDNA recombination, if this indeed occurs.

Acknowledgments

This research received support from the Italian Ministry of the University (Progetti Ricerca Interesse Nazionale 2005) (to A.T.); Fondo Investimenti Ricerca di Base 2001 (to A.T. and G.V.); Fondazione Cariplo (to A.T.); European Union grants EUMITOCOMBAT, MitEURO, and MITOCIRCLE Projects (to M.Z.); Fondazione Telethon-Italy grants GGP030039 (to M.Z.) and E.0890 (to A.T.); Fondazione Pierfranco e Luisa Mariani (to M.Z.); and Fondazione Gino Galletti (to V.C.). We also thank Maria Odete Moschen, for her invaluable efforts in assembling the SOA-BR family pedigree, and International Foundation for Optic Nerve Disease, for the generous support to its investigation. Finally, we acknowledge all the ophthalmologists who referred the Italian patients to the diagnostic centers.

Web Resources

Accession numbers and URLs for data presented herein are as follows:

GenBank, <http://www.ncbi.nlm.nih.gov/Genbank/> (for the complete mtDNA sequences [accession numbers DQ341083–DQ341090])
Online Mendelian Inheritance in Man (OMIM), <http://www.ncbi.nlm.nih.gov/Omim/> (for LHON)

References

- Achilli A, Rengo C, Battaglia V, Pala M, Olivieri A, Fornarino S, Magri C, Scozzari R, Babudri N, Santachiara-Benerecetti AS, Bandelt HJ, Semino O, Torroni A (2005) Saami and Berbers—an unexpected mitochondrial DNA link. *Am J Hum Genet* 76:883–886
- Achilli A, Rengo C, Magri C, Battaglia V, Olivieri A, Scozzari R, Cruciani F, Zeviani M, Briem E, Carelli V, Moral P, Dugoujon J-M, Roostalu U, Loogväli E-L, Kivisild T, Bandelt H-J, Richards M, Villems R, Santachiara-Benerecetti AS, Semino O, Torroni A (2004) The molecular dissection of mtDNA haplogroup H confirms that the Franco-Cantabrian glacial refuge was a major source for the European gene pool. *Am J Hum Genet* 75:910–918
- Acin-Perez R, Bayona-Bafaluy MP, Fernandez-Silva P, Moreno-Lo-shuertos R, Perez-Martos A, Bruno C, Moraes CT, Enriquez JA (2004) Respiratory complex III is required to maintain complex I in mammalian mitochondria. *Mol Cell* 13:805–815
- Andrews RM, Kubacka I, Chinnery PF, Lightowlers RN, Turnbull DM, Howell N (1999) Reanalysis and revision of the Cambridge reference sequence for human mitochondrial DNA. *Nat Genet* 23:147
- Autere J, Moilanen JS, Finnila S, Soininen H, Mannermaa A, Hartikainen P, Hallikainen M, Majamaa K (2004) Mitochondrial DNA polymorphisms as risk factors for Parkinson's disease and Parkinson's disease dementia. *Hum Genet* 115:29–35
- Brown MD, Sun F, Wallace DC (1997) Clustering of Caucasian Leber hereditary optic neuropathy patients containing the 11778 or 14484 mutations on an mtDNA lineage. *Am J Hum Genet* 60:381–387

- Carelli V, Ghelli A, Ratta M, Bacchilega E, Sangiorgi S, Mancini R, Leuzzi V, Cortelli P, Montagna P, Lugaresi E, Degli Esposti M (1997) Leber's hereditary optic neuropathy: biochemical effect of the 11778/ND4 and 3460/ND1 mutations and correlation with the mitochondrial genotype. *Neurology* 48:1623-1632
- Carelli V, Ross-Cisneros FN, Sadun AA (2004) Mitochondrial dysfunction as a cause of optic neuropathies. *Prog Retin Eye Res* 23:53-89
- D'Aurelio M, Gajewski CD, Lin MT, Mauck WM, Shao LZ, Lenaz G, Moraes CT, Manfredi G (2004) Heterologous mitochondrial DNA recombination in human cells. *Hum Mol Genet* 13:3171-3179
- De Benedictis G, Rose G, Carrieri G, De Luca M, Falcone E, Passarino G, Bonafe M, Monti D, Baggio G, Bertolini S, Mari D, Mattace R, Franceschi C (1999) Mitochondrial DNA inherited variants are associated with successful aging and longevity in humans. *FASEB J* 13:1532-1536
- Dudkina NV, Eubel H, Keegstra W, Boekema EJ, Braun HP (2005) Structure of a mitochondrial supercomplex formed by respiratory-chain complexes I and III. *Proc Natl Acad Sci USA* 102:3225-3229
- Ghezzi D, Marelli C, Achilli A, Goldwurm S, Pezzoli G, Barone P, Pellecchia MT, Stanzione P, Brusa L, Bentivoglio AR, Bonuccelli U, Petrozzi L, Abbruzzese G, Marchese R, Cortelli P, Grimaldi D, Martinelli P, Ferrarese C, Garavaglia B, Sangiorgi S, Carelli V, Torroni A, Albanese A, Zeviani M (2005) Mitochondrial DNA haplogroup K is associated with a lower risk of Parkinson's disease in Italians. *Eur J Hum Genet* 13:748-752
- Hofmann S, Jaksch M, Bezold R, Mertens S, Aholt S, Paprotta A, Gerbitz KD (1997) Population genetics and disease susceptibility: characterization of central European haplogroups by mtDNA gene mutations, correlation with D loop variants and association with disease. *Hum Mol Genet* 6:1835-1846
- Houshmand M, Sharifpanah F, Tabasi A, Sanati MH, Vakilian M, Lavasani SH, Joughheidoust S (2004) Leber's hereditary optic neuropathy: the spectrum of mitochondrial DNA mutations in Iranian patients. *Ann N Y Acad Sci* 1011:345-349
- Howell N, Elson JL, Chinnery, PF, Turnbull, DM (2005) mtDNA mutations and common neurodegenerative disorders. *Trends Genet* 21:583-586
- Howell N, Oostra R-J, Bolhuis PA, Spruijt L, Clarke LA, Mackey DA, Preston G, Herrnstadt C (2003) Sequence analysis of the mitochondrial genomes from Dutch pedigrees with Leber hereditary optic neuropathy. *Am J Hum Genet* 72:1460-1469
- Kivisild T, Shen P, Wall DP, Do B, Sung R, Davis KK, Passarino G, Underhill PA, Scharfe C, Torroni A, Scozzari R, Modiano D, Coppa A, de Knijff P, Feldman MW, Cavalli-Sforza LL, Oefner PJ (2005) The role of selection in the evolution of human mitochondrial genomes. *Genetics* (<http://www.genetics.org/cgi/rapidpdf/genetics.105.043901v1>) (electronically published September 19, 2005; accessed January 20, 2006)
- Kraytsberg Y, Schwartz M, Brown TA, Ebralidse K, Kunz WS, Clayton DA, Vissing J, Khrapko K (2004) Recombination of human mitochondrial DNA. *Science* 304:981
- Laberge A-M, Jomphe M, Houde L, Vézina H, Tremblay M, Desjardins B, Labuda D, St-Hilaire M, Macmillan C, Shoubridge EA, Brais B (2005) A "fille du roy" introduced the T14484C Leber hereditary optic neuropathy mutation in French Canadians. *Am J Hum Genet* 77:313-317
- Lamminen T, Huoponen K, Sistonen P, Juvonen V, Lahermo P, Aula P, Nikoskelainen E, Savontaus ML (1997) mtDNA haplotype analysis in Finnish families with Leber hereditary optic neuropathy. *Eur J Hum Genet* 5:271-279
- Lodi R, Carelli V, Cortelli P, Iotti S, Valentino ML, Barboni P, Pallotti F, Montagna P, Barbiroli B (2002) Phosphorus MR spectroscopy shows a tissue specific in vivo distribution of biochemical expression of the G3460A mutation in Leber's hereditary optic neuropathy. *J Neurol Neurosurg Psychiatry* 72:805-807
- Lodi R, Montagna P, Cortelli P, Iotti S, Cevoli S, Carelli V, Barbiroli B (2000) Secondary 4216/ND1 and 13708/ND5 Leber's hereditary optic neuropathy mitochondrial DNA mutations do not further impair in vivo mitochondrial oxidative metabolism when associated with the 11778/ND4 mitochondrial DNA mutation. *Brain* 123:1896-1902
- Macaulay V, Hill C, Achilli A, Rengo C, Clarke D, Meehan W, Blackburn J, Semino O, Scozzari R, Cruciani F, Taha A, Shaari NK, Raja JM, Ismail P, Zainuddin Z, Goodwin W, Bulbeck D, Bandelt HJ, Oppenheimer S, Torroni A, Richards M (2005) Single, rapid coastal settlement of Asia revealed by analysis of complete mitochondrial genomes. *Science* 308:1034-1036
- Macmillan C, Johns TA, Fu K, Shoubridge EA (2000) Predominance of the T14484C mutation in French-Canadian families with Leber hereditary optic neuropathy is due to a founder effect. *Am J Hum Genet* 66:332-335
- Majamaa K, Finnila S, Turkka J, Hassinen IE (1998) Mitochondrial DNA haplogroup U as a risk factor for occipital stroke in migraine. *Lancet* 352:455-456
- Man PY, Howell N, Mackey DA, Norby S, Rosenberg T, Turnbull DM, Chinnery PF (2004) Mitochondrial DNA haplogroup distribution within Leber hereditary optic neuropathy pedigrees. *J Med Genet* 41:e41
- Munakata K, Tanaka M, Mori K, Washizuka S, Yoneda M, Tajima O, Akiyama T, Nanko S, Kunugi H, Tadokoro K, Ozaki N, Inada T, Sakamoto K, Fukunaga T, Iijima Y, Iwata N, Tatsumi M, Yamada K, Yoshikawa T, Kato T (2004) Mitochondrial DNA 3644T→C mutation associated with bipolar disorder. *Genomics* 84:1041-1050
- Newman NJ (2005) Leber's optic neuropathy. In: Miller NR, Newman NJ, Biouesse V, Kerrison JB (eds) Walsh and Hoyt's clinical neurophthalmology. Williams & Wilkins, Baltimore, pp 466-476
- Niemi AK, Hervonen A, Hurme M, Karhunen PJ, Jylha M, Majamaa K (2003) Mitochondrial DNA polymorphisms associated with longevity in a Finnish population. *Hum Genet* 112:29-33
- Niemi AK, Majamaa K (2005) Mitochondrial DNA and ACTN3 genotypes in Finnish elite endurance and sprint athletes. *Eur J Hum Genet* 13:965-969
- Palanichamy Mg, Sun C, Agrawal S, Bandelt H-J, Kong Q-P, Khan F, Wang C-Y, Chaudhuri TK, Palla V, Zhang Y-P (2004) Phylogeny of mitochondrial DNA macrohaplogroup N in India, based on complete sequencing: implications for the peopling of South Asia. *Am J Hum Genet* 75:966-978
- Pyle A, Foltynie T, Tiangyou W, Lambert C, Keers SM, Allcock LM, Davison J, Lewis SJ, Perry RH, Barker R, Burn DJ, Chinnery PF (2005) Mitochondrial DNA haplogroup cluster UKJT reduces the risk of PD. *Ann Neurol* 57:564-567
- Quintana-Murci L, Chaix R, Wells RS, Behar DM, Sayar H, Scozzari R, Rengo C, Al-Zahery N, Semino O, Santachiara-Benerecetti AS, Coppa A, Ayub Q, Mohyuddin A, Tyler-Smith C, Qasim Mehdi S, Torroni A, McElreavey K (2004) Where West meets East: the complex mtDNA landscape of the southwest and central Asian corridor. *Am J Hum Genet* 74:827-845
- Reynier P, Penisson-Besnier I, Moreau C, Savagner F, Vielle B, Emile J, Dubas F, Malthiery Y (1999) mtDNA haplogroup J: a contributing factor of optic neuritis. *Eur J Hum Genet* 7:404-406
- Ross OA, McCormack R, Curran MD, Duguid RA, Barnett YA, Rea IM, Middleton D (2001) Mitochondrial DNA polymorphism: its role in longevity of the Irish population. *Exp Gerontol* 36:1161-1178
- Ross OA, McCormack R, Maxwell LD, Duguid RA, Quinn DJ, Barnett YA, Rea IM, El-Agnaf OM, Gibson JM, Wallace A, Middleton D, Curran MD (2003) mt4216C variant in linkage with the mtDNA TJ cluster may confer a susceptibility to mitochondrial dysfunction resulting in an increased risk of Parkinson's disease in the Irish. *Exp Gerontol* 38:397-405
- Ruiz-Pesini E, Lapeña AC, Diez-Sánchez C, Pérez-Martos A, Montoya J, Alvarez E, Diaz M, Urries A, Montoro L, López-Pérez MJ, Enriquez JA (2000) Human mtDNA haplogroups associated with high or reduced spermatozoa motility. *Am J Hum Genet* 67:682-696

- Sadun AA, Carelli V, Salomao SR, Berezovsky A, Quiros PA, Sadun F, DeNegri AM, Andrade R, Moraes M, Passos A, Kjaer P, Pereira J, Valentino ML, Schein S, Belfort R (2003) Extensive investigation of a large Brazilian pedigree of 11778/haplogroup J Leber hereditary optic neuropathy. *Am J Ophthalmol* 136:231–238
- Sadun F, De Negri AM, Carelli V, Salomao SR, Berezovsky A, Andrade R, Moraes M, Passos A, Belfort R, Bastos Da Rosa A, Quiros P, Sadun AA (2004) Ophthalmologic findings in a large pedigree of 11778/haplogroup J Leber hereditary optic neuropathy. *Am J Ophthalmol* 137:271–277
- Salomao SR, Berezovsky A, Andrade RE, Belfort R, Carelli V, Sadun AA (2004) Visual electrophysiologic findings in patients from an extensive Brazilian family with Leber's hereditary optic neuropathy. *Doc Ophthalmol* 108:147–155
- Torrioni A, Campos Y, Rengo C, Sellitto D, Achilli A, Magri C, Semino O, Garcia A, Jara P, Arenas J, Scozzari R (2003) Mitochondrial DNA haplogroups do not play a role in the variable phenotypic presentation of the A3243G mutation. *Am J Hum Genet* 72:1005–1012
- Torrioni A, Petrozzi M, D'Urbano L, Sellitto D, Zeviani M, Carrara F, Carducci C, Leuzzi V, Carelli V, Barboni P, De Negri A, Scozzari R (1997) Haplotype and phylogenetic analyses suggest that one European-specific mtDNA background plays a role in the expression of Leber hereditary optic neuropathy by increasing the penetrance of the primary mutations 11778 and 14484. *Am J Hum Genet* 60:1107–1121
- Torrioni A, Rengo C, Guida V, Cruciani F, Sellitto D, Coppa A, Calderon FL, Simionati B, Valle G, Richards M, Macaulay V, Scozzari R (2001) Do the four clades of the mtDNA haplogroup L2 evolve at different rates? *Am J Hum Genet* 69:1348–1356
- Torrioni A, Wallace DC (1994) Mitochondrial DNA variation in human populations and implications for detection of mitochondrial DNA mutations of pathological significance. *J Bioenerg Biomembr* 26:261–271
- Valentino ML, Avoni P, Barboni P, Pallotti F, Rengo C, Torrioni A, Bellan M, Baruzzi A, Carelli V (2002) Mitochondrial DNA nucleotide changes C14482G and C14482A in the ND6 gene are pathogenic for Leber's hereditary optic neuropathy. *Ann Neurol* 51:774–778
- van der Walt JM, Nicodemus KK, Martin ER, Scott WK, Nance MA, Watts RL, Hubble JP, et al (2003) Mitochondrial polymorphisms significantly reduce the risk of Parkinson disease. *Am J Hum Genet* 72:804–811
- Vergani L, Martinuzzi A, Carelli V, Cortelli P, Montagna P, Schievano G, Carozzo R, Angelini C, Lugaesi E (1995) MtDNA mutations associated with Leber's hereditary optic neuropathy: studies on cytoplasmic hybrid (cybrid) cells. *Biochem Biophys Res Commun* 210:880–888
- Wallace DC (2005) A mitochondrial paradigm of metabolic and degenerative diseases, aging, and cancer: a dawn for evolutionary medicine. *Annu Rev Genet* 39:359–407
- Wallace DC, Singh G, Lott MT, Hodge JA, Schurr TG, Lezza AM, Elsas LJ, Nikoskelainen EK (1988) Mitochondrial DNA mutation associated with Leber's hereditary optic neuropathy. *Science* 242:1427–1430
- Wang Q, Ito M, Adams K, Li BU, Klopstock T, Maslim A, Higashimoto T, Herzog J, Boles RG (2004) Mitochondrial DNA control region sequence variation in migraine headache and cyclic vomiting syndrome. *Am J Med Genet A* 131:50–58
- Zsurka G, Kraytsberg Y, Kudina T, Kornblum C, Elger CE, Khrapko K, Kunz WS (2005) Recombination of mitochondrial DNA in skeletal muscle of individuals with multiple mitochondrial DNA heteroplasmy. *Nat Genet* 37:873–877