



FULL-LENGTH ARTICLE

Design, comparative study and analysis of CDMA for different modulation techniques



Arun Kumar^{a,*}, Manisha Gupta^b

^a Dept of ECE, JECRC University, Jaipur 303905, India

^b Dept of Physics, JECRC University, Jaipur 303905, India

Received 8 June 2015; accepted 27 July 2015

Available online 6 September 2015

KEYWORDS

MIMO;
 MMSE;
 BER;
 QAM-64;
 QAM-256

Abstract In this work, we have design a MIMO–CDMA using 4 * 8 antennas with the combination of MMSE (Minimum Mean square Error Equalizer) for BPSK (Binary Phase shift Keying), QPSK (Quadrature Phase Shift Keying), 16-QAM, 64-QAM and 256-QAM (Quadrature Amplitude Modulation) modulation schemes. The analysis is built on the basis of transmit–received signal, constellation and MMSE plot simulated on a MatLab/Simulink. On the basis of BER (Bit-Error-Rate), it is also concluded that this work is mostly suitable for high order modulation schemes as the BER of 16-qam, 64-QAM and 256-QAM is zero. The proposed study has increased the quality of the wireless link and Inter-Symbol-Interference (ISI) is likewise cut by applying a combination of MMSE and MIMO (Multiple In and Multiple Out) with OSTBC (Orthogonal space Time Block Code) encoder and combiner.

© 2015 Production and hosting by Elsevier B.V. on behalf of Faculty of Computers and Information, Cairo University. This is an open access article under the CC BY-NC-ND license (<http://creativecommons.org/licenses/by-nc-nd/4.0/>).

1. Introduction

CDMA is multiple access technology where a multiple user uses a same channel and communicates with each other. Each user has given a unique code due to which CDMA becomes one of the most secured communication systems. In CDMA,

the transmission bandwidth is more as compared to the bandwidth of the original signal. Here, the signal at the transmitter is spread, modulate through a channel and at the receiver the signal is de-spread and demodulate to the received original signal from modulated wave. Mathematically it is shown below:

Let $X(t)$ be the original message to be send (1)

Spreading the signal $X(t)$ is given as follows:

$$Y(t) = X(t) \text{ XOR } B(t) \quad (2)$$

where $B(t)$ is a pseudo sequence generator and $Y(t)$ transmits a signal.

Once more on the channel there is an addition OF noise (n) so Eq. (2) becomes

$$Y(t) = X(t) \text{ XOR } B(t) + n \quad (3)$$

* Corresponding author.

E-mail addresses: arun.kumar1986@live.com, arun.sikkim@hotmail.com (A. Kumar), manisha.gupta@jecrcu.edu.in (M. Gupta).

Peer review under responsibility of Faculty of Computers and Information, Cairo University.



Production and hosting by Elsevier

At the receiver the signal is de-spread with $B(t)$ and demodulated, Hence

$$Z(t) = Y(t)XOR B(t) \quad (4)$$

where $Z(t)$ is receiving signal.

CDMA can efficiently use the spectrum, can also increase the capacity and data-rate in communication organization, but the disadvantage of CDMA is that it needs a high power in a circuit and sometime due to the interference the call can be ended. In gain to it, Inter-Symbol-Interference (ISI) is a biggest problem in CDMA. When two or more signals are so tight to each other than it results in ISI. In that respect are different equalizers that can melt off the ISI but it cannot be totally eliminated and one of the disadvantages of using equalizer is that it's hardware implementation is so complex [1]. The performance of CDMA has drastically reduced in multipath environment due to the fading of the signal which in-turn reduces the quality of the radio link. In this paper, we have used four antennas at transmitters and 8 antennas at receivers so that the receiver will receive eight signals; so out of eight one best signals can be selected and can be processed further. The data rate and capacity can also be drastically increased if we can send four different signals at a same frequency by using an efficient DSP algorithm. In the proposed employment, the analyses of MIMO-CDMA are clearly shown so that one can select the best modulation scheme and can likewise know the behavior of MIMO-CDMA system under the different modulation scheme. The BER is also computed for different modulation schemes. BER may be defined as the error in transmitting signal to the ratio of total transmit bits. BER occurs due to noise, interference, and distortion in the signal.

2. Related work

8 * 8 MIMO system is designed by using a BPSK modulation technique where the focus was to amend the design of CDMA Mobile in a fading environment and also amended the design frequency of the system using an efficient matrix inversion technique [2,3]. MIMO-MC-DS-CDMA is designed at low SNR two stage and MMSE out-execute the single stage, whereas at high SNR single stage provides a better performance [4]. 2 * 3 MIMO-MC-CDMA is designed by using a convolution code and found that with this approach the BER is greatly reduced, which in-turn has increased throughput of the system [5]. MIMO-MC-DS-CDMA is analyzed using a chaotic spreading sequence and significant increased the performance is achieved as compared to the Walsh Hadamard spreading code [6]. Combination of Space-Time-Block-Coding and MIMO-CDMA was implemented by using 2, 3, 4 transmitter to provide the best signal diversity in the system 2 Bps Hz spectral efficiency is achieved [7]. The performance of multiple antenna MC-CDMA system was evaluated and performance of BPSK, QPSK, DPSK and QAM with different equalizers are analyzed and concluded that BPSK is a best modulation scheme as compared to other modulation techniques [8]. The author has designed a CDMA with different modulation techniques and concluded that QPSK gives better performance as compared to BPSK, ASK and FSK [9]. The author has projected and compared CDMA for BPSK, QPSK and QAM, and found that BPSK is the best modulation scheme in CDMA because it gives less BER as compared to QPSK

and QAM [10]. The author has designed and analyzed the performance of CDMA QAM-16 under AWGN and RAYLEIGH Channel and concluded that the performance of CDMA is better in AWGN channel as compared to Rayleigh Chanel [11]. An improvement in MIMO-CDMA is achieved without increasing the complexity in the receiver [12]. A Joint Transceiver was designed by combining equalizer with antenna, multiuser interference and multiantenna interference reduction is achieved [13]. 2 * 4 MIMO CDMA for 8-PSK, QPSK, QAM-16, 32, 64 is designed and work reveals that, QPSK is the best modulation scheme with high gain as compared to other modulation schemes [14]. 256-Qam CDMA modulator with zero error was simulated result reveals that the BER performance of the proposed system was equivalent to theoretical QAM BER [15]. The performance of the CDMA MMSE receiver was analyzed and predicted user capacity can be increased with a high order modulation scheme to cause the MMSE receiver to operate away from the interference limited region [16]. The peak rate of WC-CDMA was increase for high order modulation scheme by using a powerful control with combination of rate allocation scheme [17].

3. Modulation technique

In General, modulation system may be defined as the process of sending a message with the help of carrier, but now the efficiency and performance of communication system depend upon the choice of modulation system. In this section we discuss about BPSK, QPSK and QAM modulation techniques.

3.1. BPSK

BPSK stands for a Binary phase shift keying. When one is received there is a phase shift of 180° and when zero is received there is phase shift of 360°. The modulating signal of BPSK is given by the following equation:

$$g(t) = \sqrt{2Eb/Tb} \cos 2\pi fct \quad (a)$$

From Eq. (a) we can say that BPSK is described as one dimensional digital carrier modulation scheme. And the demodulated signal is given by

$$s = \sqrt{EB}dt + \sqrt{\frac{2}{Tb}} \int_0^{Tb} \omega t \cdot \cos(\omega ct + \theta)dt \quad (b)$$

In Eq. (b) the first term represents desired BPSK signal and second term represents the effect of noise.

3.2. QPSK

QPSK stands for a quadrature phase shift keying. The QPSK modulating signal is given by

Table 1 QAM states and data-rate.

S. No	Modulation technique	States	Data rate (Mbps)
1	QAM-16	16	24
2	QAM-64	64	30
3	QAM-256	256	40

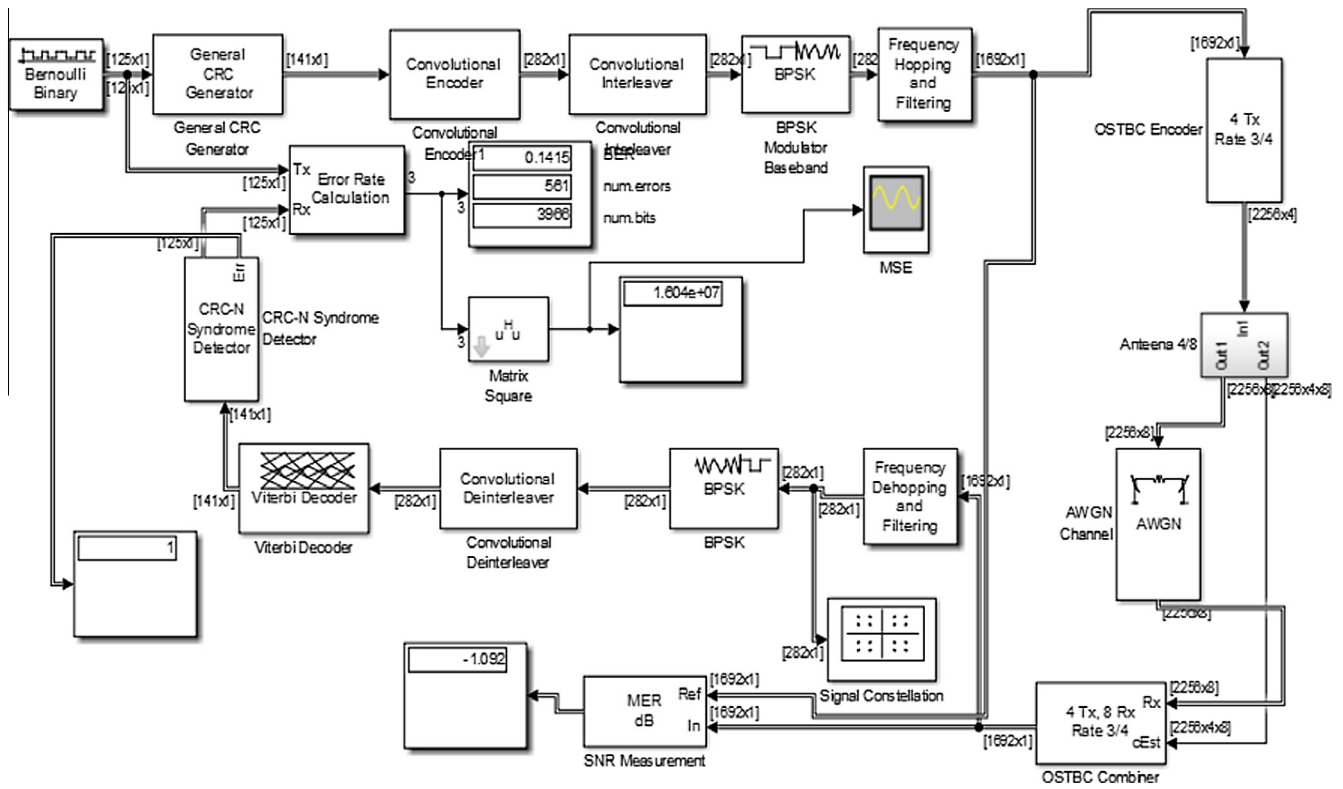

Figure 1 Proposed simulation for BPSK using 4 * 8 antennas with STBC codes.

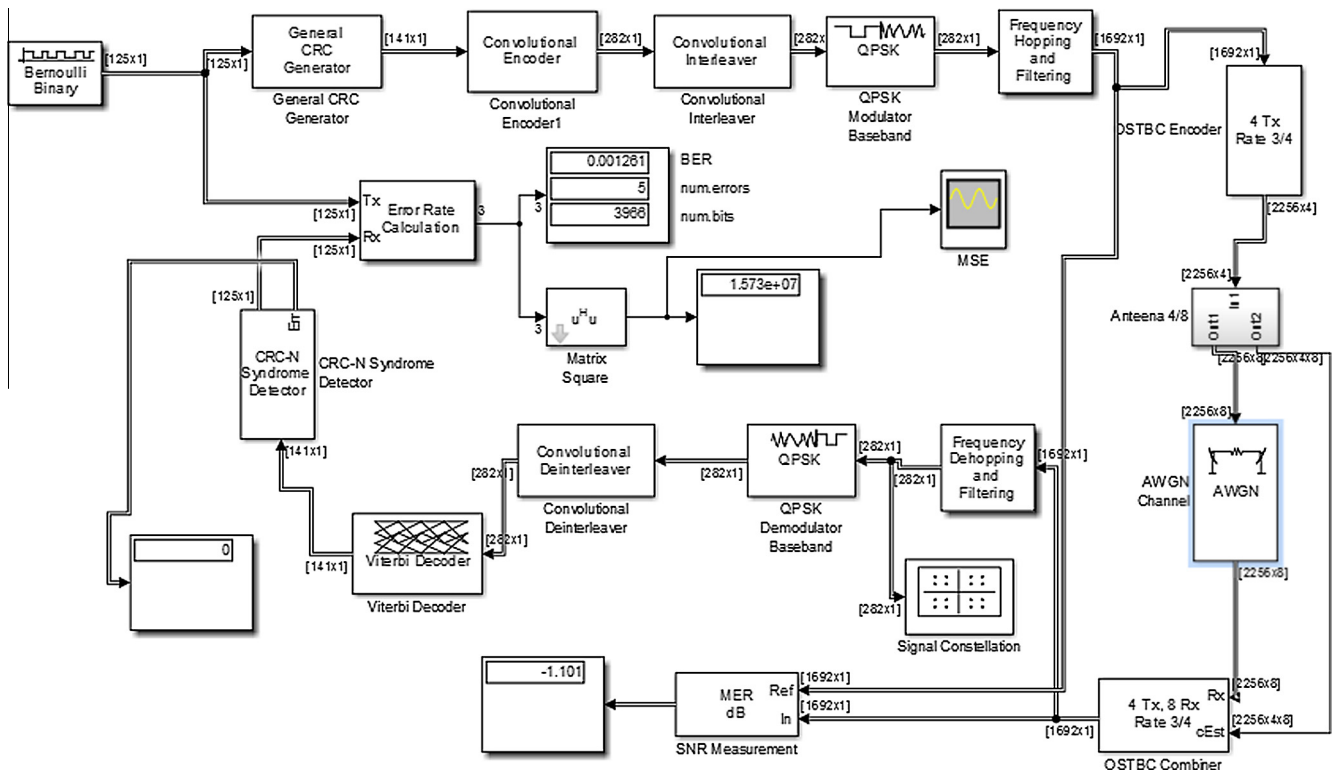

Figure 2 Proposed simulation for QPSK using 4 * 8 antennas with STBC codes.

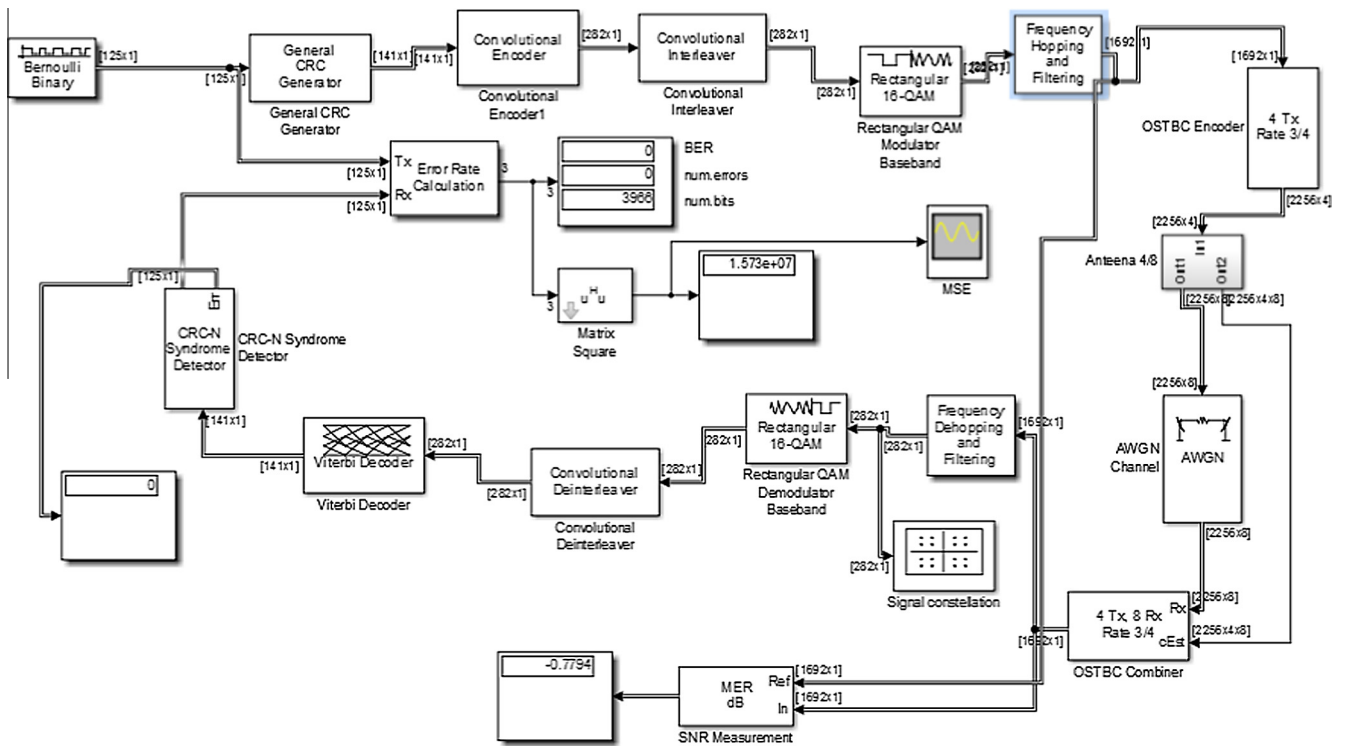

Figure 3 Proposed simulation for Qam-16 using 4 * 8 antennas with STBC codes.

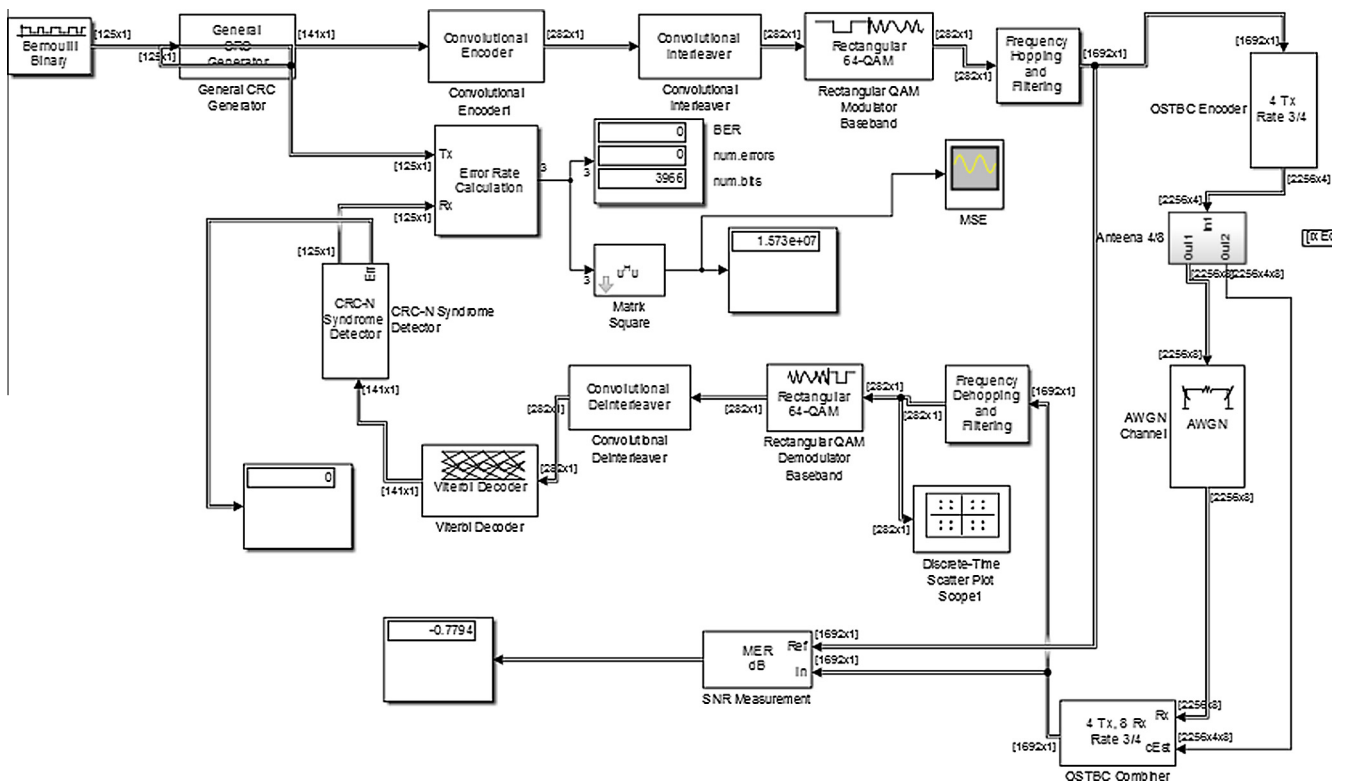

Figure 4 Proposed simulation for Qam-64 using 4 * 8 antennas with STBC codes.

which allows the low frequency to pass and blocking the high order frequency signal. The different modulation schemes with states and data-rate are shown in Table 1.

4. Proposed methodology

The proposed simulated block diagram for MIMO CDMA using 4×8 antennas for BPSK, QPSK, 16-QAM, 64-QAM and 256-QAM is shown in Figs. 1–5. A Bernoulli Binary generator is used as an input which generates random numbers whose output is given to a CRC generator which generates

the CRC bit according to the generator polynomial used (here 16 bit polynomial is used) and CRC bit appends them to an input data frame. The convolution encoder encodes the CRC generated data whose output is given to a convolution encoder which consists of an N shift register which shifts the bit from one shift register to another and its output I modulated by using a modulator (BPSK, QPSK and QAM). A combination of frequency hopping and digital filter is used to avoid the interference with another device, to transmit the modulated data by switching a carrier among many frequencies and to filter out the signal whose output is encoded at the rate of $\frac{3}{4}$ by using an OSTBC encoder. The encoded output is transmitted

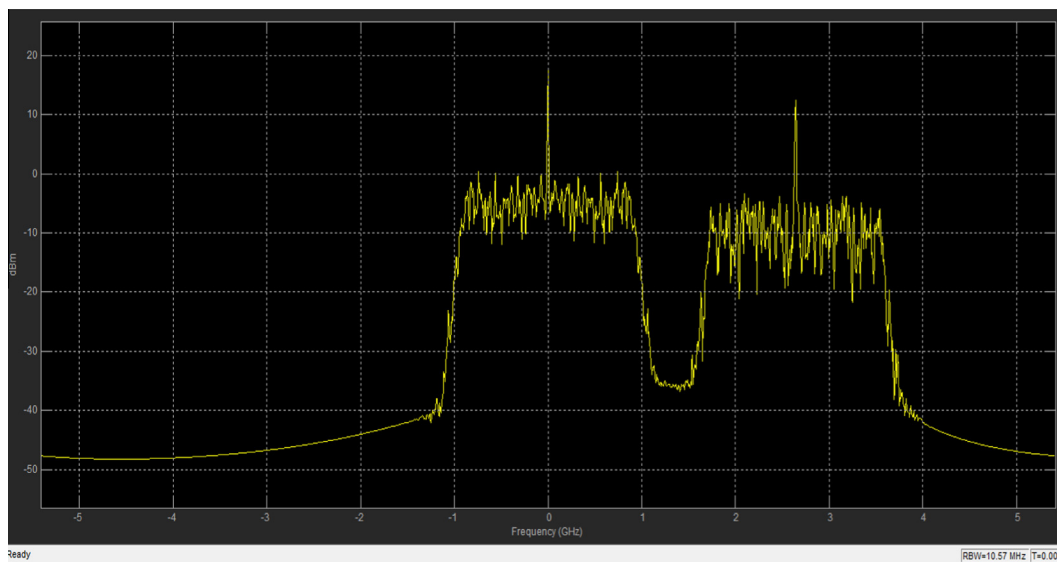

Figure 7 Transmitted signal for QPSK.

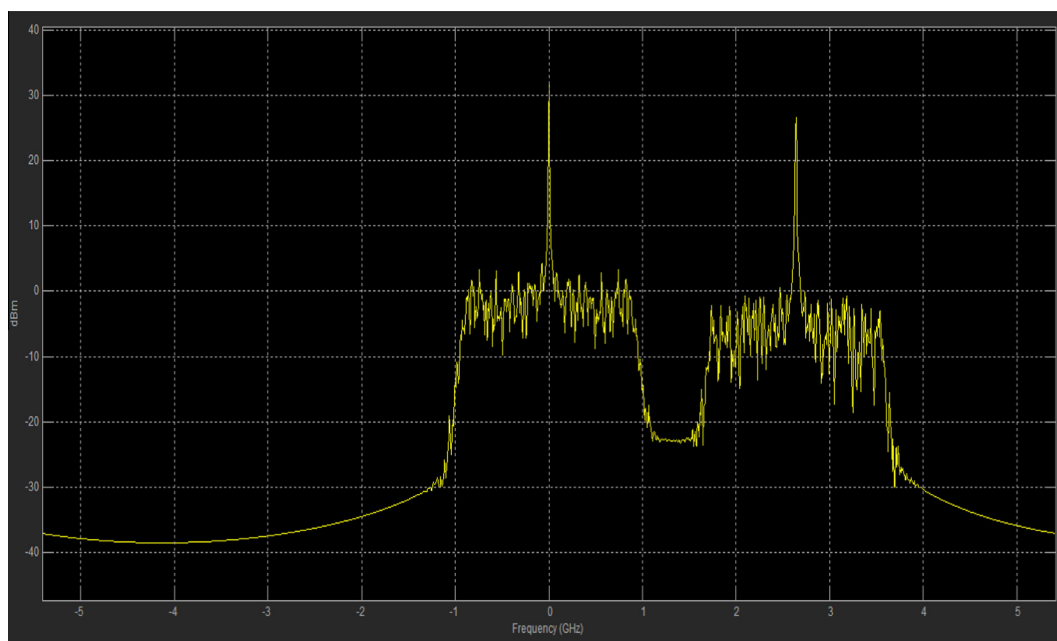

Figure 8 Transmitted signal for 16-QAM.

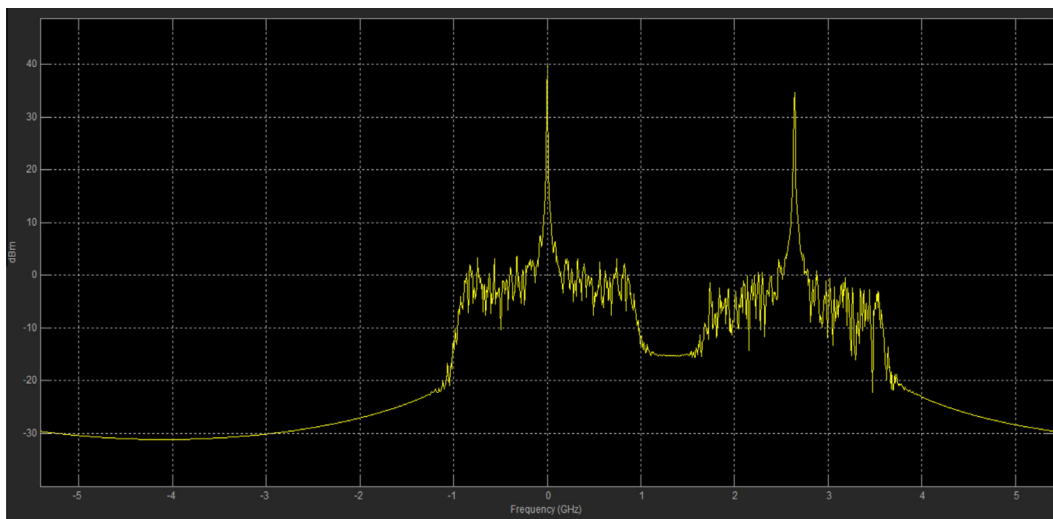

Figure 9 Transmitted signal for 64-QAM.

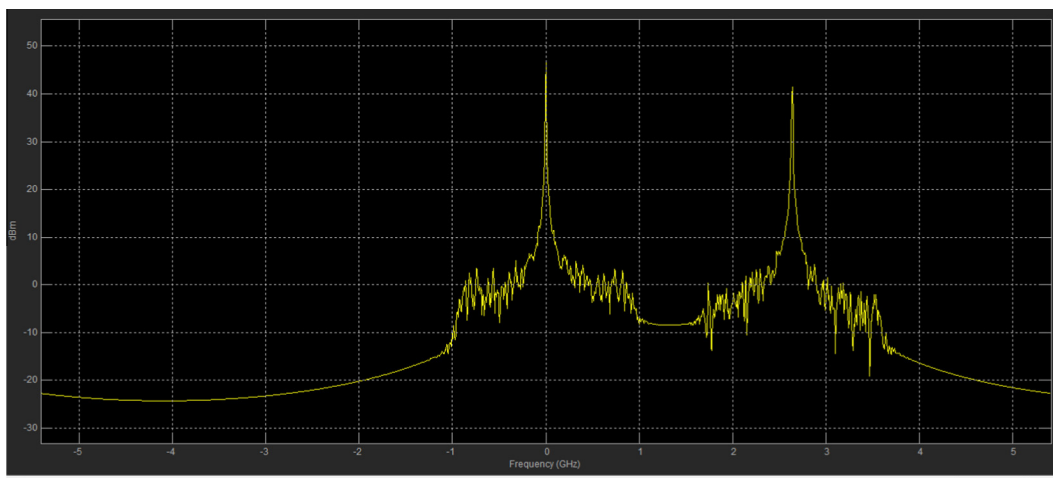

Figure 10 Transmitted signal for 256-QAM.

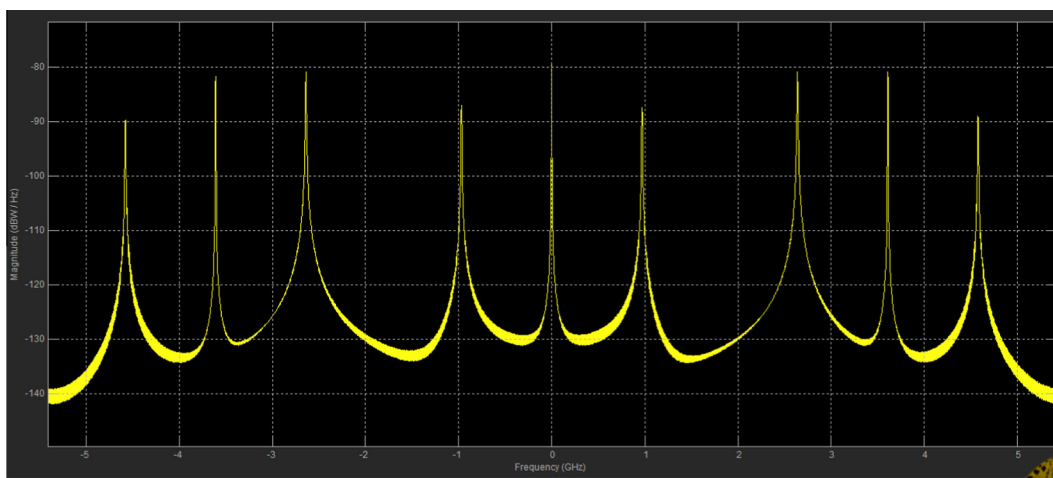

Figure 11 Received signal for BPSK.

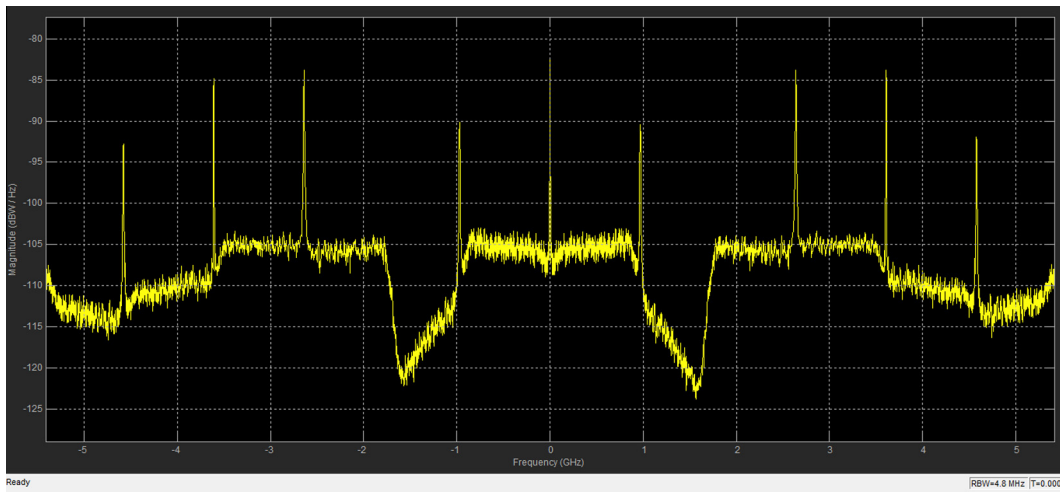

Figure 12 Received signal for QPSK.

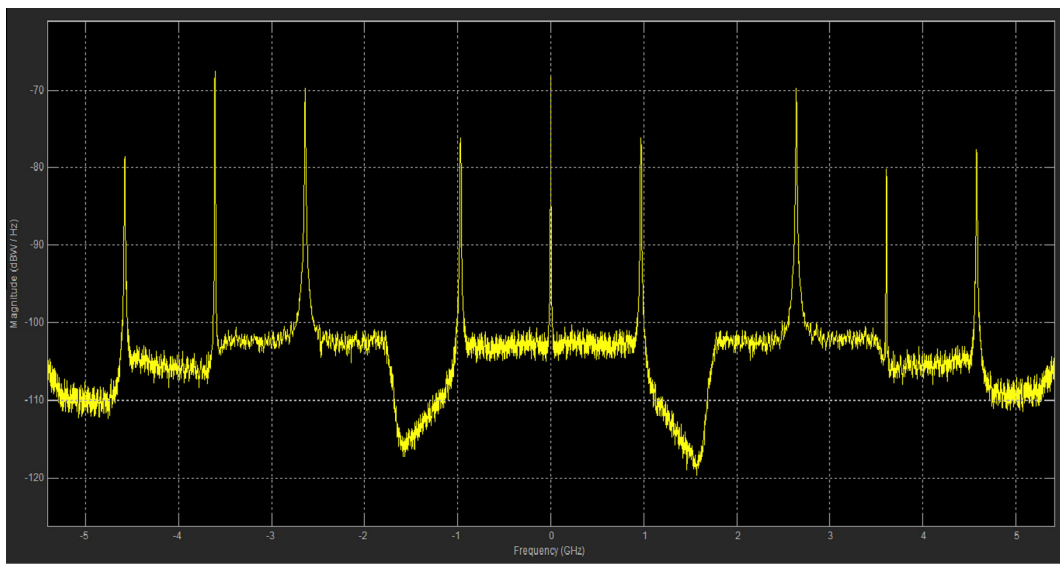

Figure 13 Received signal for 16-QAM.

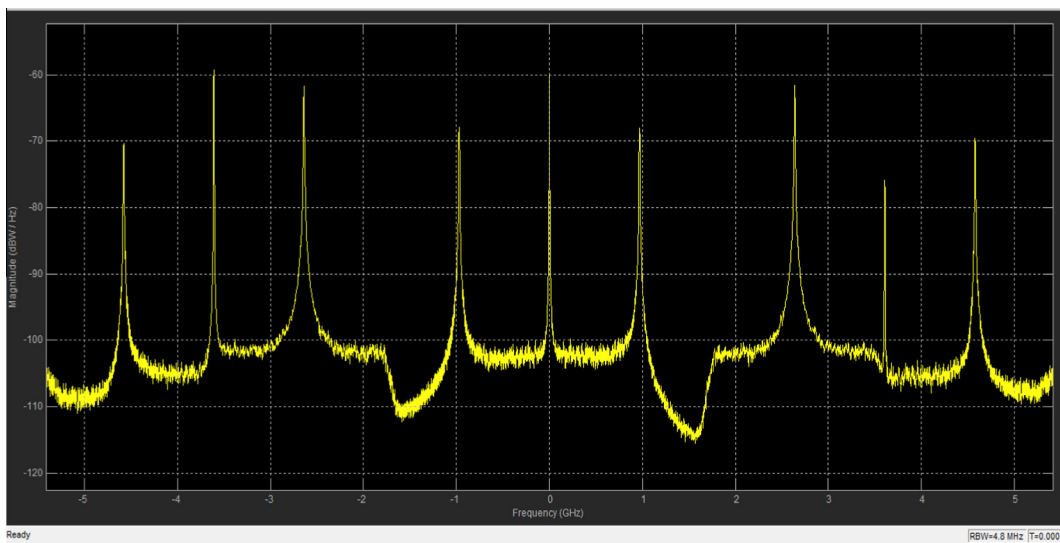

Figure 14 Received signal for 64-QAM.

by using a four transmitter antennas and received by using an eight receiver antennas over an AWGN channel. The output of AWGN channel and 8 receiver antennas is combined by using an OSTBC combiner and given to frequency de-hopping and digital filter which de-hops the signal and filters out the unwanted signal. The output of digital filters is demodulated and de-interleaved by using a convolution de-interleaver whose output is decoded by using a Viterbi decoder and decoded signal is given to a CRCN syndrome detector which detects the error in input data frame. Finally, the CRC detector output is given to an error detector and MMSE Equalizer where the former calculates the BER, transmitted signal and error in the signal and the MMSE Equalizer further reduces the error in the symbol by computing the efficient outer and the inner products.

5. MIMO antenna

MIMO stands for multiple inputs and multiple outputs which mean a multiple antenna at transmitter and receiver in a communication system. The performance of communication system has been greatly affected by co-channel interference and multi path fading, MIMO plays a very important role to eradicate the effect of fading and co-channel interference. Thus increasing the capacity, data-rate, radio link and also efficiently utilizing the spectrum. The MIMO system used a large number of antenna arrays and by using an efficient DSP algorithm it is also possible to makes them smart which study's the environment and takes the decision on the basis of environment condition. In this paper, four transmitting antennas and eight receiving antennas is used and the MIMO is implemented

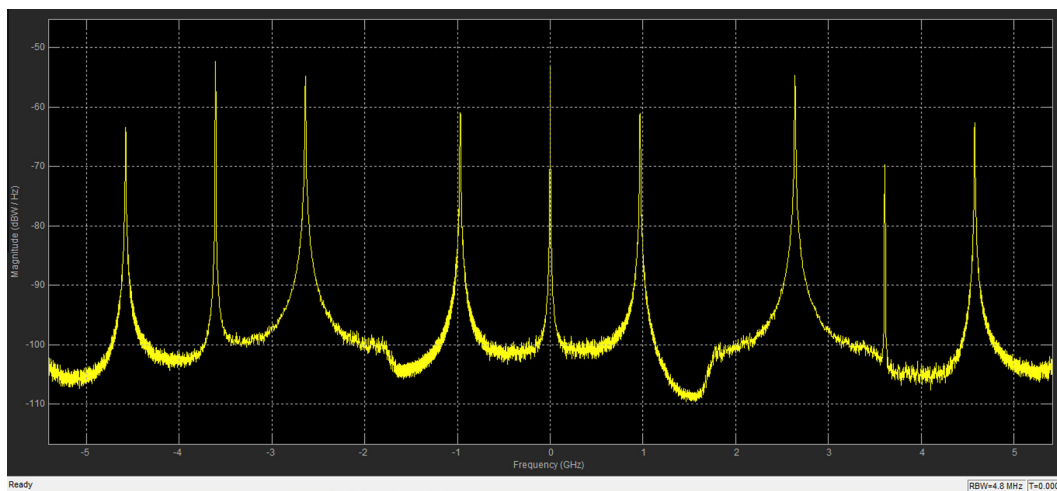

Figure 15 Received signal for 256-QAM.

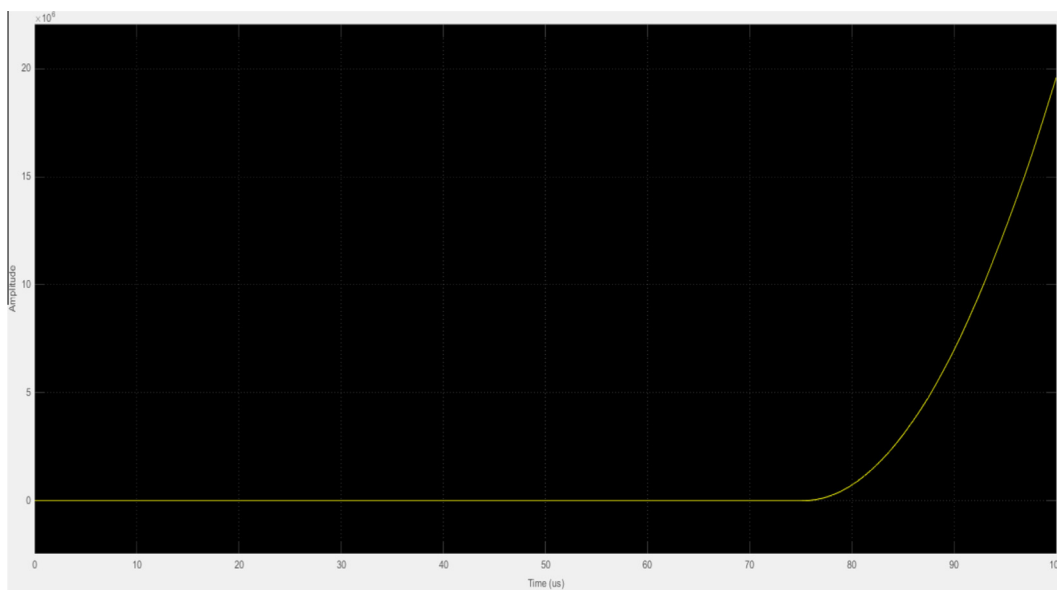

Figure 16 MMSE plot for BPSK.

by using OSTBC Code. The transmitted and received signals are described in [14].

6. OSTBC codes

Let us consider a signal $X_k = \{x_1, x_2, x_3, x_4, \dots, \dots, x_n\}$ to be transmitted. As compared to traditional approach x_1 signal will transmit at first time slot and x_2 at second time slot but in this paper x_1-x_4 signals will transmit at first time slot and $-x_1^*$ to $-x_2^*$ at second time slot. Each transmitting antenna is independent from the channel condition experience by other antennas. By increasing the number of antennas, power efficiency is also achieved and also increases the capacity and data

rate of a communication system [18]. As the number of antenna is increased in transmitter and receiver, the capacity is also increased and also the capacity of MIMO is more as compared than SISO, MISO, and SIMO which were studied in [19,20,21].

7. Simulation results

7.1. Transmitted signal

The spectrum of BPSK, QPSK, QAM-16, QAM-64 and QAM-256 transmitted signals is shown in Figs. 6–10, which is generated by using a Bernoulli binary generator. The

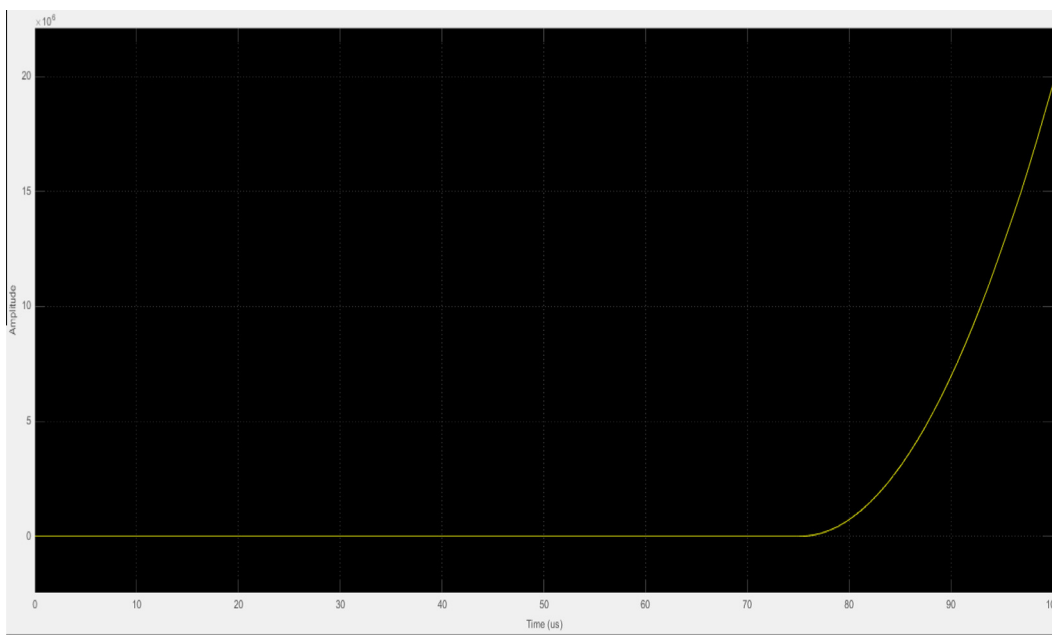

Figure 17 MMSE plot for QPSK.

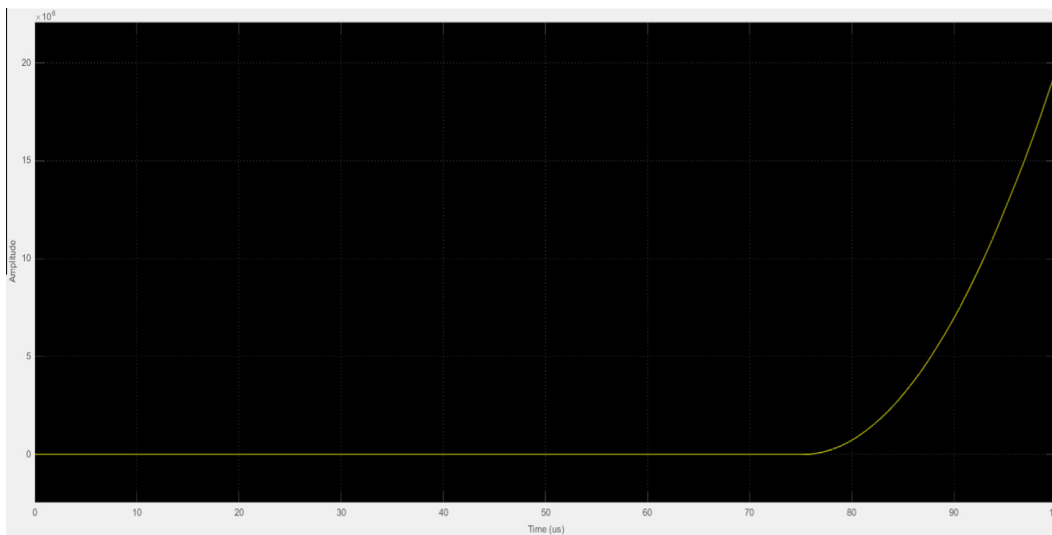

Figure 18 MMSE plot for 16-QAM.

RWB is used at 3.90 MHz, and the span between the signals is 3.17 GHz. For BPSK as shown in Fig. 6, the maximum peaks are 3.098 m at -0.564 GHz, 3.331 m at 0.740 GHz and 3.334 at -0.74011 GHz. The channel power is 20.851 dBm with an occupied bandwidth of 1.8733 GHz and the frequency error is -58.3493 KHz. For QPSK as shown in Fig. 7, the maximum peaks are 12.435 m at 2.642 GHz, 17.540 m at -0 GHz and 326.484 m at -0.740 GHz. The channel power is 20.851 dBm with occupied bandwidth of 1.824 GHz and the frequency error is -147.1921 KHz. For 16-QAM as shown in Fig. 8, the maximum peaks are 31.736 m at 0 GHz, 26.610 m at 2.642 GHz and 4.296 m at 0.070 GHz. The channel power is 33.366 dBm with an occupied bandwidth of 1.6097 GHz and the frequency error is 101.5707 KHz. For 64-QAM as shown

in Fig. 9, the maximum peaks are 39.586 m at 0 GHz, 34.636 at 2.642 GHz and 7.463 at -0.070 GHz. The channel power is 40.223 dBm with an occupied bandwidth of 413.2104 MHz and the frequency error is 15.1533 MHz. For 256-QAM as shown in Fig. 10, the maximum peaks are 46.790 m at 0 GHz, 41.530 m at 2.642 GHz and 12.353 m at -0.070 GHz. The channel power is 47.117 dBm with an occupied bandwidth of 64.0060 MHz and the frequency error is 1.6499 MHz.

7.2. Received signal

The spectrum of BPSK, QPSK, 16-QAM, 64-QAM and QAM-256 received signals is shown in Figs. 11–15, which is obtained

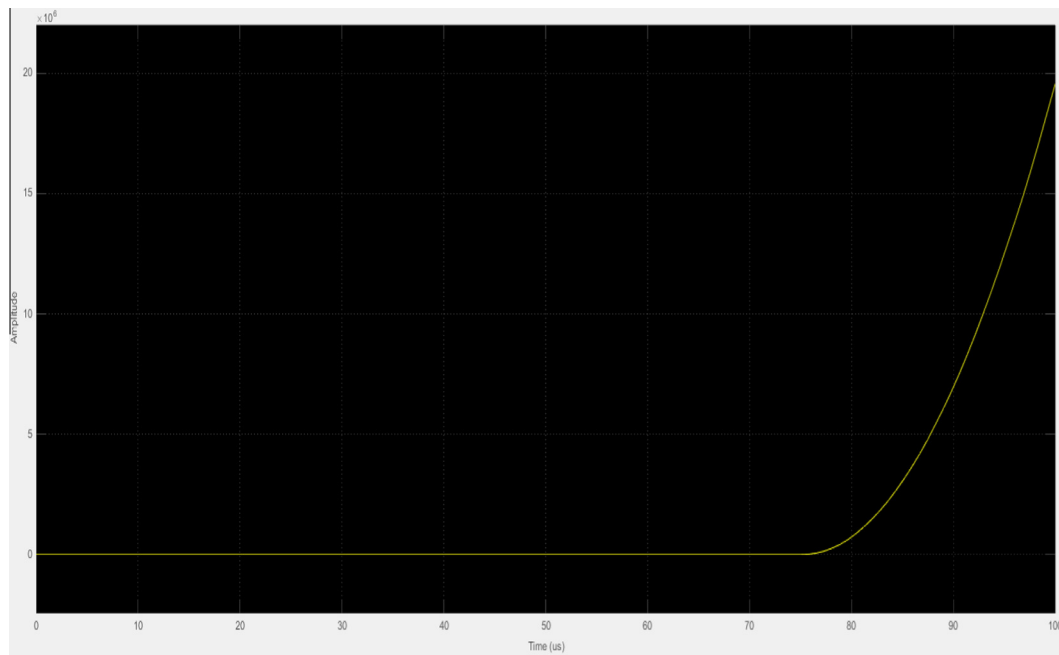

Figure 19 MMSE plot for QAM-64.

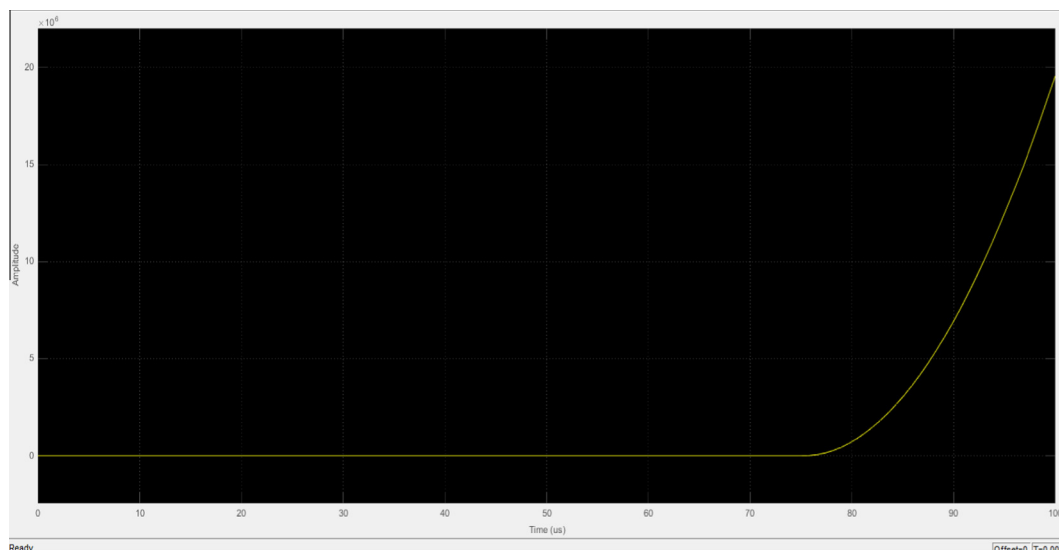

Figure 20 MMSE plot of QAM-256.

by demodulating the modulated wave. Here RWB and the span are 4.8 MHz and 3.90 MHz. The figure shows three peaks i.e. maximum peak when there is an excellent coverage, medium peak when there is a good coverage and zero peak corresponds to poor coverage. For BPSK as shown in Fig. 11, the maximum peaks are -100.558 m at 3.461 GHz, -100.550 at 0.147 GHz and -100.515 m at 0.224 GHz. The channel power is -10.214 dBW with occupied bandwidth of 2.0599 GHz and the frequency error is -1.722 MHz. For QPSK as shown in Fig. 12, the maximum peaks are -83.835 at -2.638 GHz, -83.768 m at -2.642 GHz and -52.629 at 0 GHz. The channel power is -9.889 dB with occupied bandwidth of 1.988 GHz and the frequency error is -2.4997 MHz. For 16-QAM as

shown in Fig. 13, the maximum peaks are -69.694 m at -2.638 GHz, -68.470 V at 0 GHz and -67.683 m at -3.609 GHz. The channel power is 1.264 dBW with occupied bandwidth of 1.9726 GHz and the frequency error is -1.1350 MHz. For 64-QAM as shown in Fig. 14, the maximum peaks are -59.303 m at -3.609 GHz, -60.199 m at 0 GHz and -61.632 m at 2.630 GHz. The channel power is 9.193 dB with occupied bandwidth of 1.9075 Hz and the frequency error is -1.251 MHz. For 256-QAM as shown in Fig. 15, the maximum peaks are -52.481 m at -3.609 GHz, -53.387 m at 0 GHz and -54.598 at 2.638 GHz. The channel power is 16.054 dBm with occupied bandwidth of 1.9707 GHz and the frequency error is -1.3197 MHz.

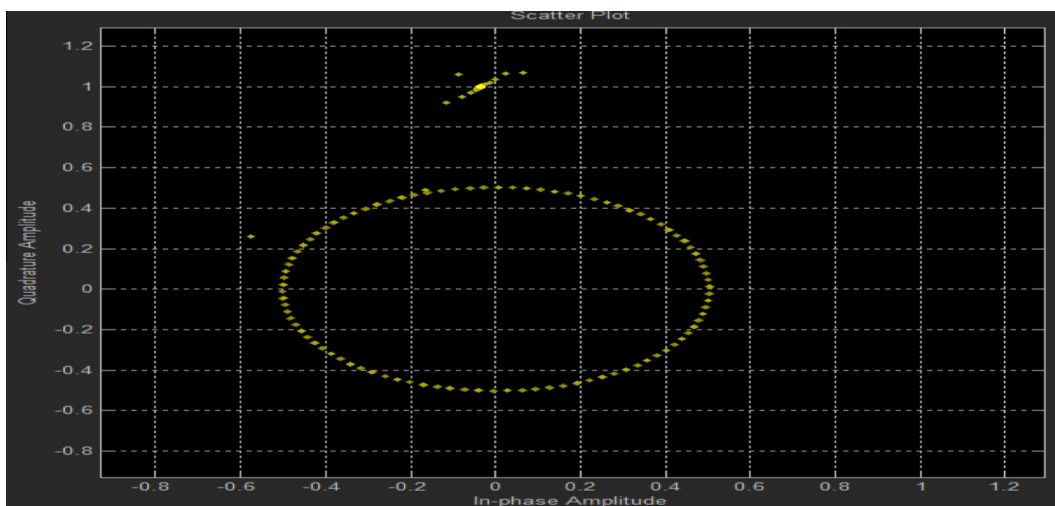

Figure 21 Scatter plot of BPSK.

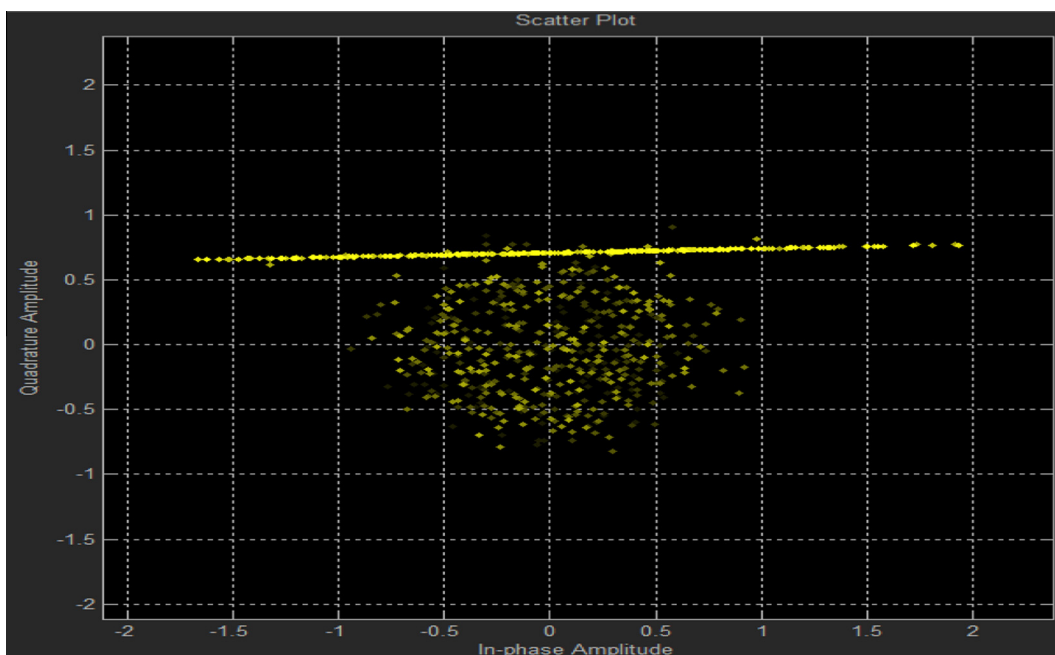

Figure 22 Scatter plot of QPSK.

7.3. MMSE plot

The plot of Amplitude vs. time denotes an MMSE plot which is the output of the mean square equalizer. It squares the input signal and produces a reduced error which is useful to minimize the Inter-symbol-interference. The MMSE value of BPSK is given by $1.959e^{+07}$, maximum peak is 19.586 m at $T = 100 \mu\text{s}$ with peak to peak given by 19.586 m and Root Mean square value is 4.527 mm. As shown in Fig. 16, the amplitude is exponentially increasing with increase in rise time of 10.997 μs . The MMSE value of QPSK is given by $1.678e^{+07}$, maximum peak is 19.630 m at $T = 100 \mu\text{s}$ with peak to peak given by 19.630 m and Root Mean square value is 4.521 m. As shown in Fig. 17, the amplitude is exponentially increasing with increase in rise time of 11.022 μs . The MMSE value of 16-QAM is given by $1.961e^{+07}$, maximum peak is 19.610 at $T = 1 \mu\text{s}$ with peak to peak given by 19.610 m and Root Mean square value is 4.521 m. As shown in Fig. 18, the amplitude is

exponentially increasing with increase in rise time of 11.024 μs . The MMSE value of 64-QAM is given by $1.955e^{+07}$, maximum peak is 19.551 m at $T = 1 \mu\text{s}$ with peak to peak given by 19.551 m and Root Mean square value is 4.510 m. As shown in Fig. 19, the amplitude is exponentially increasing with increase in rise time of 11.023 μs . The MMSE value of 256-QAM is given by $1.961e^{+07}$, maximum peak is 19.571 m at $T = 1 \mu\text{s}$ with peak to peak given by 19.571 m and Root Mean square value is 4.514 m. As shown in Fig. 20, the amplitude is exponentially increasing with increase in rise time of 11.028 μs .

7.4. Constellation diagram

The constellation diagram of BPSK, QPSK, 16-QAM, 64-QAM and 256-QAM is shown in Figs. 21–25. The input constellation diagram is also known as a physical diagram which demonstrates all the probable symbols used by the communi-

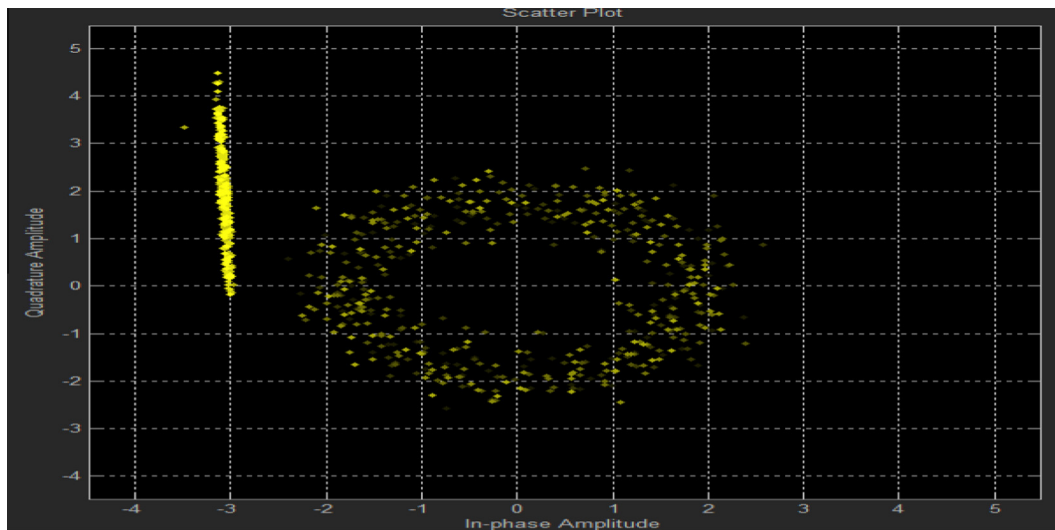

Figure 23 Scatter plot of 16-QAM.

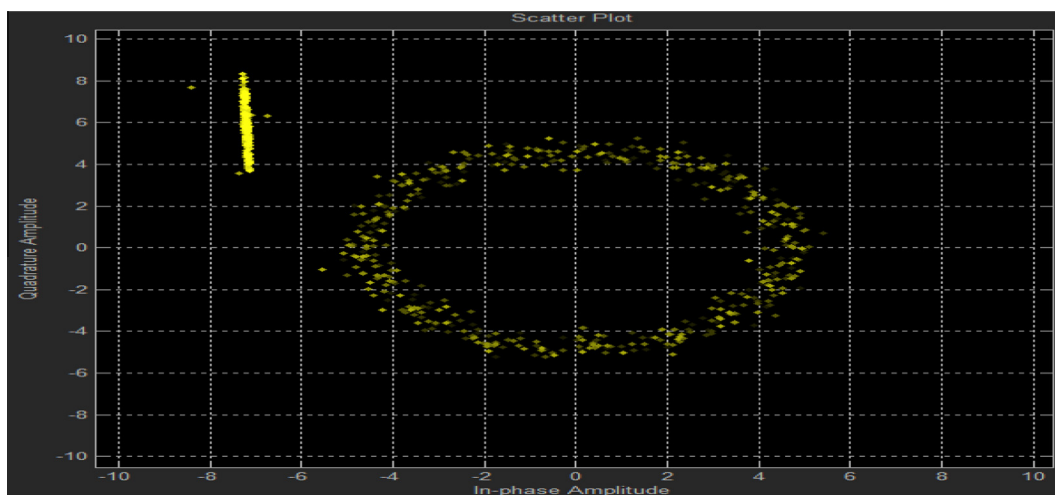

Figure 24 Scatter plot of 64-QAM.

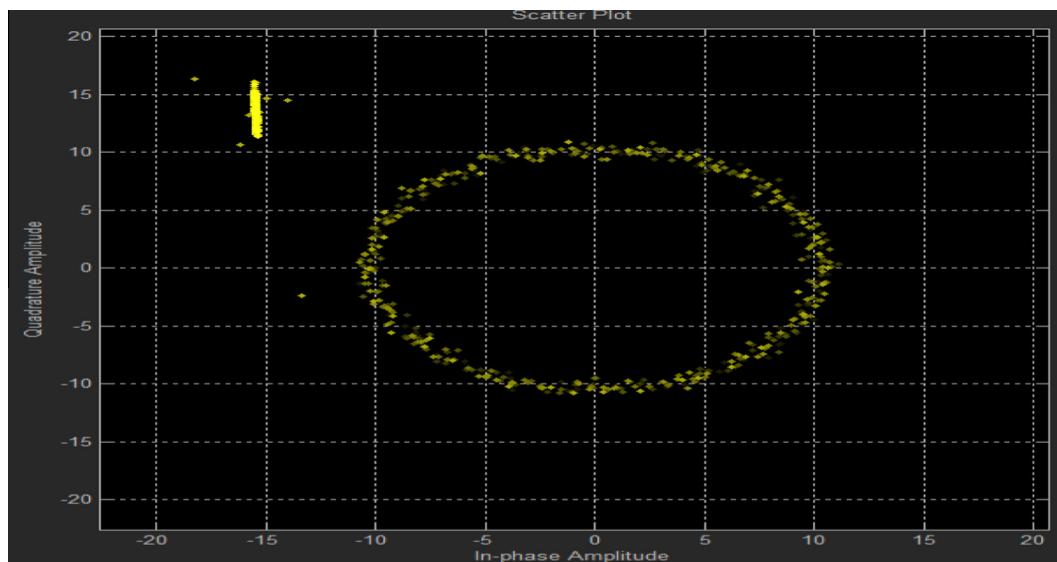

Figure 25 Scatter plot of QAM-256.

Table 2 CDMA parameters and BER.

Eb/No in dB	1	5	10	20	30	40
BPSK BER	0.1415	0.1314	0.1072	0.09884	0.1026	0.1024
QPSK BER	0.00126	0.0022	0.00075	0.000504	0.0005043	0.0002521
16-QAM BER	0	0	0	0	0	0
64-QAM BER	0	0	0	0	0	0
256-QAM BER	0	0	0	0	0	0

cation system to transmit the data. For BPSK as shown in Fig. 21, EVM gives -1.294 dB with a peak value of -1.08 dB and MER is 1.294 dB. For QPSK as shown in Fig. 22, EVM gives -12.051 dB with a peak value of -10.26 dBm and MER is 12.052 dB. For 16-QAM as shown in Fig. 23, EVM gives 9.657 dB with a peak value of 10.764 dBm and MER is -9.657 dB. For 64-QAM as shown in Fig. 24, EVM gives 18.711 dB with a peak value of 19.191 dBm and MER is -18.711 dB. For 256-QAM as shown in Fig. 25, EVM gives 25.985 dB with a peak value of 24.206 dBm and MER is -25.985 dB.

8. Conclusion

It is concluded that with higher order modulation scheme, there is an efficient utilization of spectrum and data rate is also enhanced at the cost of high inter-symbol interference and complex transmitter and receiver. The 4×8 MIMO CDMA with a combination of OSTBC and MSE Equalizer is simulated for the BPSK, QPSK, QAM-16, 64 and 256 modulation schemes. From the analysis of Transmitted and received signal spectrum, MSE and Scatter plot, it is concluded that QPSK performance is better as compared to BPSK but overall QAM-16, 64 and 256 is most suitable for massive MIMO system. It is also found that the proposed work efficiently reduces the ISI and also has increased the performance as compared to the conventional CDMA system since the achieve BER is low for QPSK, BPSK and zero for QAMs. The work also gives a

motivation to implement a large number of MIMO for next generation network because implementation of large MIMO can only meet the demands and expectation of telecommunication for future generation. The BER performance of this modulation schemes is given in Table 2.

References

- [1] Suman, Rishipal E, Kumar A, Gupta M. A review on optimization of inter symbol interference for transmitter and receiver of CDMA, UWB and OFDM for high order modulation technique. *Int J Sci Eng Res* 2014;5(3):724–9.
- [2] Yasodha T. Decoding for 8×8 MIMO system using convolution coding implemented in VLSI. *Int J Eng Res Appl* 2013;3():278–82.
- [3] Jalal J Hamad Ameen. 8×8 MIMO system transmission characteristic with MC-CDMA multiplexing for next generation mobile system. *Pensee J* 2014;76(6):295–307.
- [4] Nagaradjane P, Vasana A, Krishnan L, Swamy A. Adaptive co-channel interference suppression technique for multi user MIMO MC-DS/CDMA system. *Int J Commun Network Syst Sci* 2009;2():822–9.
- [5] Kushwah A, Manglasheril S. Performance estimation of 2×3 MIMO-MC-CDMA using convolution codes. *Int J Comput Trend Technol* 2014;9(1):21–5.
- [6] Nagarajuna V, Dananjagan N. Performance analysis of MIMO MC-DS-CDMA system using chaotic spreading sequence. *Int J Comput Electr Eng* 2010;2(2):329–33.
- [7] Le Nir V, Auffray JM, Helard M, Helard JF, Le Gooabe R. Combination of space time block coding with MC-CDMA

- technique for MIMO system with two, three and four transmitter. <ftp://itp.estal.kuleuvenbe>.
- [8] Faisal M, Hossain M, Enaget S, Ullah H. Performance evaluation of multiple antenna MC-CDMA system on color transmission image under implementation of various signal detection techniques. *Int J Adv Sci Technol* 2012;41(1):71–82.
- [9] Kumar A, Naznin R. Simulation of different modulation technique in CDMA system using AWGN channel. *Int J Comput Technol* 2013;11(3):2277–3061.
- [10] Kumar A, Gupta M. Comparative study and analysis of BER of CDMA for different modulation scheme. *Int J Comput Technol* 2014;12(8):3839–43.
- [11] Kumar A, Gupta M. Analysis and simulation of CDMA QAM-16 for AWGN and Rayleigh channel. *Int J Electron Commun Comput Eng* 2014;5(4):2278–4209.
- [12] Min Shi D, Amours C, Yoagacogh A. Design of spreading permutation for MIMO-CDMA based on space time block code. *IEEE Commun Lett* 2010;14(1):36–8.
- [13] Zamiri Jafarian H, Rajabzadeh M. Joint transceiver design for uplink MIMO-MC = CDMA system. In: 19th Iranian conference on electrical engineering, 2011. p. 1–5.
- [14] Bliss Daniel W, Forsythe Keith W, Amanda M. MIMO wireless communication. *Lincoln Lab* 2005;15(1):97–126.
- [15] Joon Woo Shin, Hyeong Jun Park, Dae Soon Cho, Chang Wan Yoo, Yoon Ok Park, Deuk Soo Lyu. The implementation of 256 QAM CDMA modulator. In: 6th IEEE international conference, HSNMC 2003, Estoril, Portugal, July 23–25, 2003, proceedings, vol. 2720; 2003. p. 326–32.
- [16] Almutairi Ali F, Latchman Haniph A, Wang T, Lee Minkyui, Miller Scott L. Performance of MMSE receiver based CDMA system with high order modulation format in a fading channel. *Wireless Personal Commun* 2003;25(2):117–36.
- [17] Sofiene Affes, Karim Cheikh Rouhoo, Faker Moatemri, khaled Lajnef, Paul Mernelstein. A high order modulation space time receiver with increased peak rate and throughput for wide band CDMA. In: Proceeding Eurasia, University of Quebec Cannada [18] www.dsplog.com.
- [19] Sengar K, Rani N, Singhal A, Sharma D, Verma S, Singh T. Study and capacity evaluation of SISO, MISO and MIMO RF wireless communication systems. *Int J Eng Trends Technol (IJETT)* 2014;9(9):437–40.
- [20] Giri N, Sahoo A, Swain JR, Kumar P, Nayak A, Debogswami P. Capacity & performance comparison of SISO and MIMO system for next generation network (NGN). *Int J Adv Res Comput Eng Technol (IJARCET)* 2014;3(9):3031–6.
- [21] Dey S, Vandana R, Patikrit U. Capacity calculation and performance analysis of different transmission structures in wireless communication. *Int J Latest Trends Eng Technol (IJLTET)* 2014;4(4):134–6.