



ELSEVIER



# Integrating Refinement into Software Development Tools

Lu Yang<sup>1</sup>

*State Key Laboratory of Novel Software Technology  
Department of Computer Science and Technology, Nanjing University  
Nanjing, Jiangsu, P.R. China 210092*

Volker Stolz<sup>2</sup>

*International Institute for Software Technology  
United Nations University, Macao SAR*

---

## Abstract

It is a challenge for automatic tool support to formal design by refinement transformations. In this paper, we bring this matter to the attention of the research community and discuss a component-based model transformational approach for integrating refinement into software development tools. Models, their consistency and correctness, in an object-oriented and component-based development process are defined in rCOS, that is a refinement calculus recently developed at UNU-IIST. Correctness preserving transformations between models are formalized and proved as refinement rules in rCOS. In this paper, we will discuss on how these transformations can be implemented in the relations language of Query/View/Transformation (QVT) standardized by OMG.

*Keywords:* Model transformations, MDA, QVT, rCOS.

---

## 1 Introduction

In model based development, transformations are used in the development of an application from the earliest models of requirements to the final deployed code. It is a challenge to develop automatic transformations that preserves correctness with respect to specified properties. All application of these tools is based on the construction of a *correct model* of the system to be verified or validated. Building such a model requires high technical skills and theoretical wisdom, and there is little satisfactory tool support to it.

---

<sup>1</sup> Email:[yanglu@seg.nju.edu.cn](mailto:yanglu@seg.nju.edu.cn)

<sup>2</sup> Email:[vs@iist.unu.edu](mailto:vs@iist.unu.edu)

In our approach, we take a view that the process of developing a software system is a process of working out a proof of the final software product, with a sequence of step of constructing models with annotated properties that are verified. For this, we use the relational calculus, called rCOS [16,4], to define the models that are to be produced in a development process.

Like UML but with a formal definition, rCOS provides a method of two dimensional multi-view modelling. It also combines component-based and object-oriented modelling and design. In the horizontal dimension, rCOS allows to define a component in terms of its provided interface for syntactic type checking, the specification of the static functionality of the interface methods by the notation of *design* in UTP [17], the interaction protocol for the order of the methods in which the clients (environment) can interact with the component, and the dynamic execution behavior. Further features, such as constraints on timing and memory can also be included in the model. The nice feature of this modelling techniques is that models of different views can be introduced incrementally. In the vertical dimension, models of different views can be refined by correctness preserving transformations. The model of a whole system consists of its structural view defined by the set of components, their relations modelled by the provided and required interfaces, the interactions among components and dynamic execution of the components.

The UML graphic modelling language can be used to illustrate the models of the different views: the data structure of an interface is given by a class diagram, the protocol is shown by a sequence diagram, and the dynamic execution model is given by a state diagram.

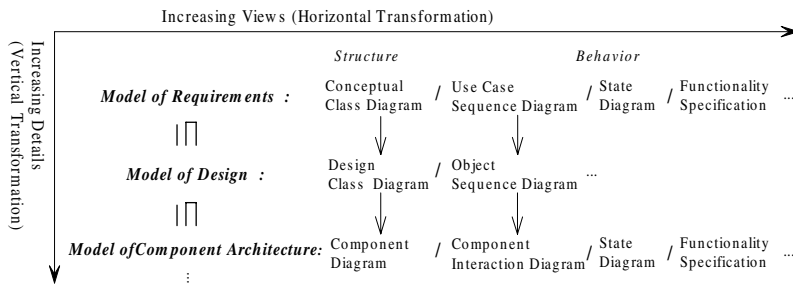

Fig. 1. Models with views and refinements

The feature of multi-view supports separation of concerns and incremental modeling, the multi-level of abstraction supports stepwise development processes by correctness preserving transformations [5].

The development process of a system is a stepwise, incremental, and iterative process and can follow the V-Model, which is a generalized version of the Waterfall Model, as shown in Fig. 1. Each subsequent model should be produced from its preceding version by applying a transformation that preserves specified properties. The theoretical frameworks supporting such a development process are usually referred to as *correctness by design*. In rCOS, correctness preserving transformations are characterized by refinement rules.

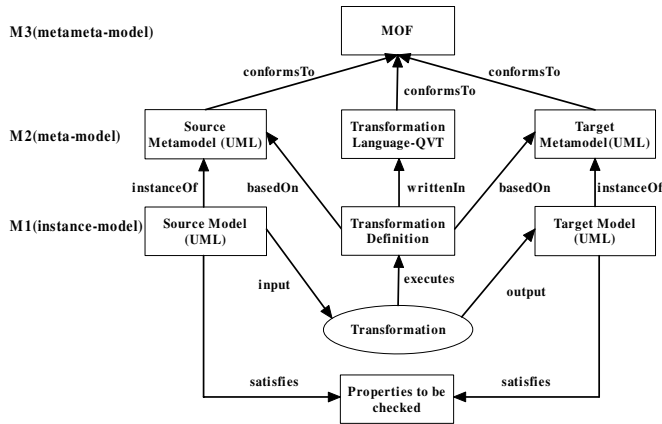

Fig. 2. Model transformation

Fig. 2 is a sketch for a model-to-model transformation. Such a transformation definition is given and realized by a transformation language such as QVT [12] which is compatible with MDA [10] standard suite: UML [13], MOF [14], OCL [15], etc., and it is used to generate a target model from a source model.

In parallel with QVT, many research groups and companies have been working on their own model transformation approaches and tools, e.g. GreAT [2], UMLX [28], AToM<sup>3</sup> [8], VIATRA [27], BOTL [20], ATL [3] and YATL [21]. These model transformation languages all have a similar operational context. They provide their own metamodels to define concrete syntaxes. Most of them are based on MOF. In [7], these model transformation approaches are classified as four categories.

- *Declarative approaches* focus on what is to be transformed into what instead of how the transformation is done.
- *Imperative approaches* focus on how the transformation are performed.
- *Hybrid approaches* are combination of the imperative and declarative approaches. These approaches allow the user to mix and match different concepts and paradigms depending on the application. Examples of the hybrid approaches include ATL [3] and QVT [12].
- *Graph-Transformation approaches* are inspired by theoretical work in graph transformations and specifically designed to represent UML-like models. These approaches are visual notations and formally founded. Examples of graph-transformation approaches include VIATRA [27], AToM3 [8], GreAT [2], UMLX [28], and BOTL [20].

Several tools and development approaches of these transformation languages are used to help the software development [26,1,9]. Also an attempt of studying the correctness and completeness of transformations in VIATRA was made in [27]. This shows a direction to introduce formal methods into model transformation languages and to help software development.

In [27], some requirements for model transformation approaches are identified, and we hope to develop tool that satisfy these requirements:

- formal, complete and minimum metamodels.
- mathematically precise description of transformation rules.
- automatic model generation from the transformation rules.
- tool for proving semantic correctness and completeness of the transformations.

We plan to use the relations language of QVT to implement the transformation, since the refinement rules in rCOS are relations between models and these refinement rules can be implemented as a relation of the transformation directly using the declarative approach, instead of being implemented as steps to be executed using the imperative approach. The transformations that implement the refinement rules are already correctness preserving transformations. As requirement of the transformation language, we need to define the metamodels and instances models that we want to transform.

### Overview

We will start with an introduction to the rCOS development process in Section 2. In Section 3 we will define the metamodels that we are going to manipulate. After that, we will discuss the implementation in QVT of our ongoing research in Section 4. Finally Section 5 concludes and discusses the further work.

## 2 rCOS Development Process

To support the correctness preserving transformation, we introduce the *normal models* of object-oriented and component-based design that can be formalized and refined in rCOS.

### 2.1 Model of requirements

The development starts from the construction and analysis of a model of requirements for a number of use cases (business processes). In such a *model of requirements*, each use case is specified as an rCOS *contract of the interface* [4]:

- The *methods of the interface* in the contract are the operations that the actors call for execution in the use case.
- The *fields of the interface* in the contract represent the data and objects needed in realizing the use case, and form a *conceptual class diagram*.
- The *functionality of the methods* is specified by pre- and post-conditions.
- The *protocol of the contract* describes the pattern in which the *actors* and the system interact in the use case and can be illustrated by a *use case sequence diagram*.

**Example 2.1** We used the example of *Point-Of-Sale (POS)* system originally proposed by Larman [18] for the implementation of the transformation. For the use case *Process Sale (Cash Desk)*, we quote the problem description used in [6]:

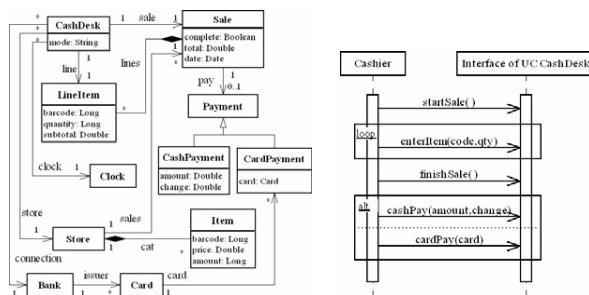

Fig. 3. Conceptual Class Diagram and Use Case Sequence Diagram

A Customer arrives at a checkout with items to purchase. The Cashier records the purchase items and handle either a cash or a card payment. On completion, the sale is logged and the inventory is updated, and the Customer leaves with the items.

Fig. 3 shows the conceptual class diagram and the use case sequence diagram of the use case *Process Sale*. The pre- and post-conditions of the methods are specified in [6].

## 2.2 Model of logical design

From the model of requirements, a model of the *logical design* is produced by first applying *object-oriented refinement* to the methods of the use cases. This is mainly to decompose the classes in the conceptual class diagrams and to decompose the functionality of the methods by delegating responsibilities to the auxiliary classes by using the *expert pattern*. This step designs the interactions among the objects and thus produces a *model of logical design* that consists of:

- A *design class diagram*, that *refines* the conceptual class diagram in the model of requirements.
- A *refinement* of each use case sequence diagram, that decompose the use case methods and delegates the partial functionalities to appropriate objects (called *expert objects*).

**Example 2.2** The designer applies the refinement rules of rCOS to the methods that we specified for the use cases. Fig. 4 show the design class diagram and the object sequence diagram that are refined from the precious diagrams in the model of requirements.

## 2.3 Model of component architecture

A further step of design is *component architectural design* in which some components are combined into larger components, and some components are decomposed into interconnected subcomponents. This produces a *model of component architecture* that includes:

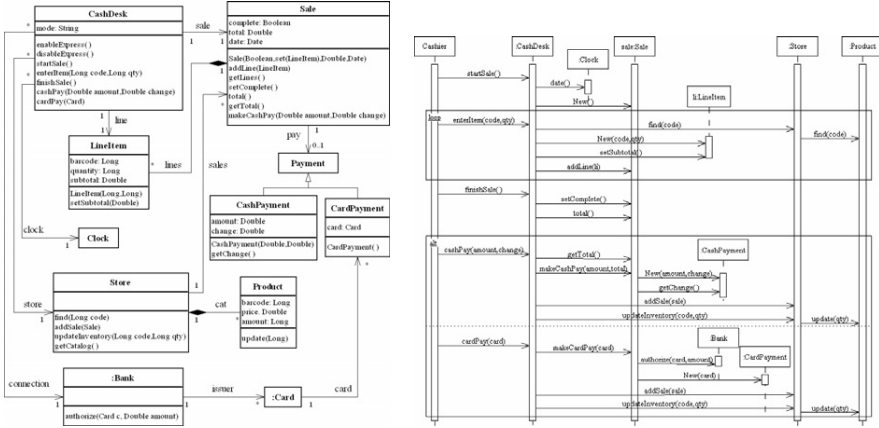

Fig. 4. Design Class Diagram and Object Sequence Diagram

- A family of components, specified with their provided and required interfaces, and this can be described as a *component diagram*.
- A set of *component interaction diagrams* that is an *abstraction and composition of the object sequence diagrams*.

Detailed design can be carried out on the component architecture so that each method in each component is designed. The components can be verified, tested and checked by various tools such as a model checker or a runtime checking tool (e.g. JML [19]).

The final step of the development is to integrate the components implementing the interfaces among components with appropriate interaction mechanisms and middlewares, such as RMI and CORBA.

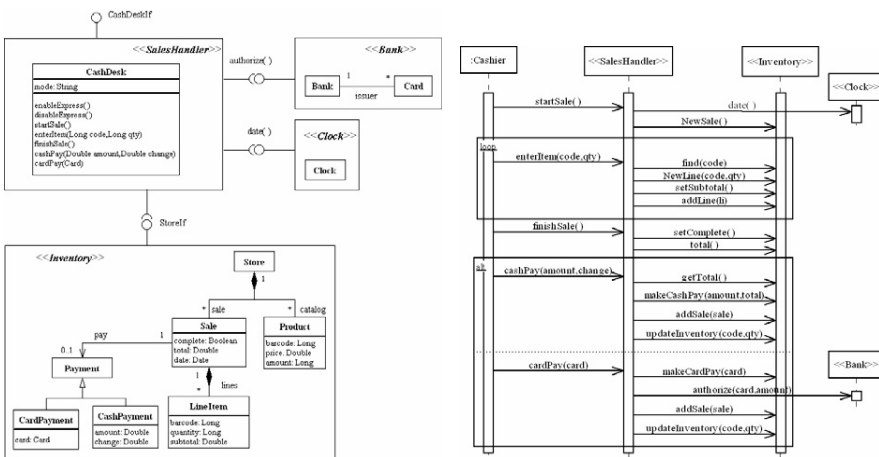

Fig. 5. Component Diagram and Component Interaction Diagram

**Example 2.3** The designer decided to partition the functions that are handled by the *CashDesk*, the *Inventory*, the *Clock* and the *Bank* considering deployment of these four parts. So the use case is partitioned to four components: *SalesHandler*,

Inventory, Clock and Bank. Fig. 5 shows the component diagram and the component interaction diagram. Then the interface of the components are specified easily in [6].

### 2.4 Tool support of the development process

These models can be used in different stages of the software development process by different roles. For example, in the MDA tool MasterCraft [24] by Tata Research Development & Design Center (TRDDC), the *Analysis Modeler* produces the model of requirements that implements the use case. Then the *Design Modeler* takes the model of requirements as input, and increases design details to produce the model of logical design that is ready for code generation. Finally, the *Architecture Modeler* may produce the model of component architecture based on the model of logical design and consider the deployment.

## 3 QVT Metamodels

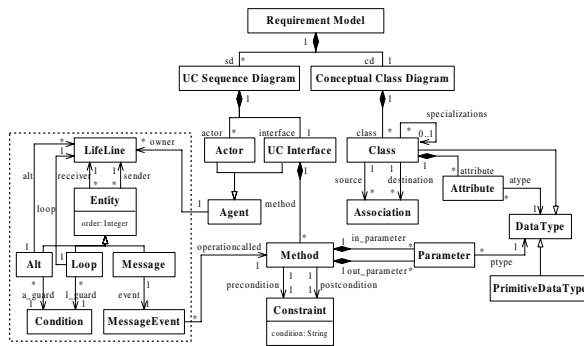

Fig. 6. Metamodel for the model of requirements

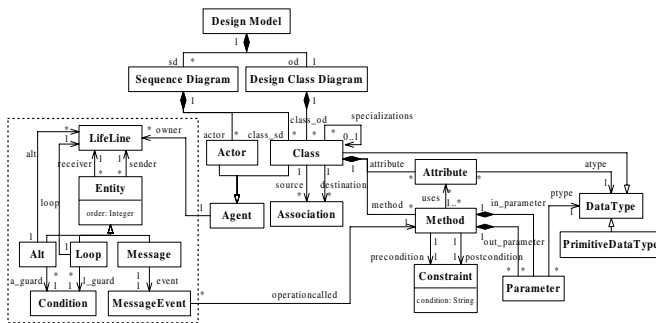

Fig. 7. Metamodel for the model of logical design

As required for the transformation language QVT, we define the QVT meta-models for the model of requirements, the model of logical design and the model of component architecture, as show in Fig. 6 - Fig. 8. In this section we will focus on the relationship among these diagrams.

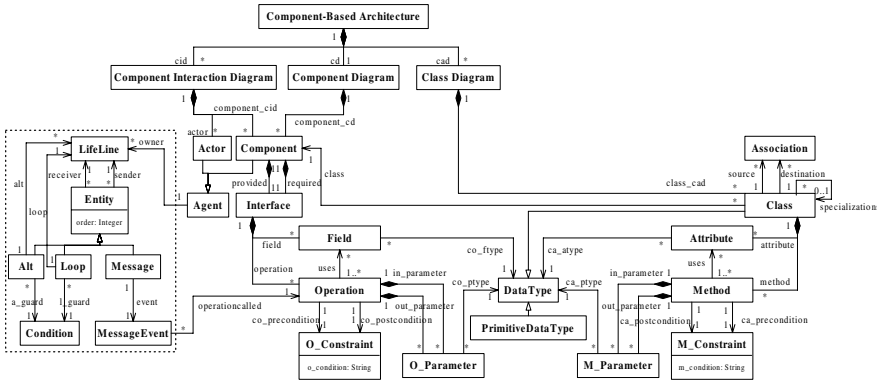

Fig. 8. Metamodel for the model of component architecture

### 3.1 QVT metamodel for the model of requirements

A conceptual class diagram contains class declarations:

- A *class* is declared with its *attributes*.
- An *association* is declared as class with roles of the association with the attributes and the role classes as their types.
- A *generalization-specialization relation* between two classes  $C_i$  and  $C_j$  is specified by  $C_j$  extends  $C_i$ .
- A *constraint* is recorded as an uninterpreted text string. It is future work to select an expression syntax that can be used in checking refinement of operations.

Most of the model elements are the same as those in the UML model, except the usage of a set of *output parameters* which is replaced by a *return type* in UML.

A use case sequence diagram represents the interactions among the actors and the use case, which consists of:

- A sequence of *entities* with the *lifelines* that send or receive the entities. The entity may be a *message*, *loop* or *alternative*.
- A *source* and a *target* of the entity. The source of the entity should be an *actor* and the target of the entity should be the *use case interface* with *methods*.
- An *order number* of the entity. The order number is given according to its position in a structure tree. The root node of the tree is corresponding to the starting actor of the sequence diagram. Then the first layer branches with order number is 1, 2, 3,  $\dots$ ,  $n$ . From the  $u$ -th node of first layer, there may be  $m$  nodes, and the corresponding order numbers of branches are  $u.1, u.2, \dots, u.m$ .  $u.v$  is the  $v$ -th branch from that node.
- A *message event* which is either a method call or a command without method calls (an internal action). For simplicity, we only consider the *call event* (method call), not the *signal event*.



### 3.2 QVT metamodel for the model of logical design

The metamodel for the design class diagram is quite like the metamodel for the conceptual class diagram except adding the declaration of the *methods* of the class.

An object sequence diagram represents the pattern of interactions among the objects. The differences between the metamodel of the use case sequence diagram and the metamodel of the object sequence diagram are:

- The *source* and the *target* of the entity should be *classes*. Of course the source of the entity can also be an *actor*.
- The *message events* are not invocations of the *methods* of the use case interface, but the *methods* of the classes.

### 3.3 QVT metamodel for the model of component architecture

In a component architecture, an interface declares a set of *fields* and a set of *operation signatures* without providing any semantic information of their designs and implementations. A component diagram is specified as follows:

- A *field* is a variable with its type.
- An *operation* declares a name for the operation and its *input parameters* and *output parameters* with their types.
- A *static functionality specification* assigned to each operation as constraints in terms of pre- and post-conditions.

The metamodel for the class diagram is also a part of the component-based architecture.

The semantics of the component interaction diagram is the protocol of the operation invocations of the component interfaces. The metamodel for the component interaction diagram is quite like the metamodel for the sequence diagram except the agent of the *lifelines* should be *components*.

Some parts of the metamodels are shared, but have to be replicated in the metamodels, e.g. the Lifeline business, as shown in the boxes in Fig. 6 - Fig. 8

## 4 Implementation of the Transformations

### 4.1 QVT relations language

To implement the transformations from model of requirements to model of component architecture based on the POS case study, we choose the relations language of MOF 2.0 QVT [12] which is a standard by OMG. QVT supports *queries*, *views* and *transformations* of models, and MOF [14] allows the development of interoperable tools for manipulating both data and metadata in a platform independent manner.

Within the QVT specification, there exist provisions for a declarative and an imperative transformation language. The relations language, which borrows from logic programming, allows structural matching on classes and navigating associations.

In the relations language, a transformation between models is specified as a set of relations that must hold. A relation is defined by two or more domains and a pair of when and where predicates.

- A domain is a distinguished typed variable that can be matched in a model of a given type. A domain pattern can be viewed as a set of variables, and a set of constraints.
- A relation can also be constrained by two sets of predicates: the when clause specifies the condition under which the relation needs to hold, and the where clause specifies the condition that must be satisfied by all model elements in the relation.

A transformation can be invoked to check two models for consistency (no side effect), or to modify one model to enforce consistency. Whether or not the relation maybe enforced is determined by the target domain, which may be marked as checkonly or enforce. When a transformation executes in the direction of the model of a checkonly domain, it is simply checked to see if there exists a valid match that satisfies the relation. When a transformation executes in the direction of the model of an enforce domain, if the checking fails, the target model is modified so as to satisfy the relation, it is a check-before-enforce semantics. The more detailed semantics of the checking and enforcement can be found in [12].

For the tool support of automatic transformation, ModelMorf [25], a QVT engine developed by TRDDC, supports the QVT relations language. The metamodels and instance models are constructed by the MetaModeler, which is also developed by TRDDC, and exported in the interchange format XMI [11]. The left of the Fig. 9 shows how to produce an instance model based on the source metamodel in the POS example using the MetaModeler. The source and target metamodels and the instance model will be exported as XMI files and taken as input of the QVT engine ModelMorf. The transformation execution of the POS example in enforce mode is shown on the right of the Fig. 9.

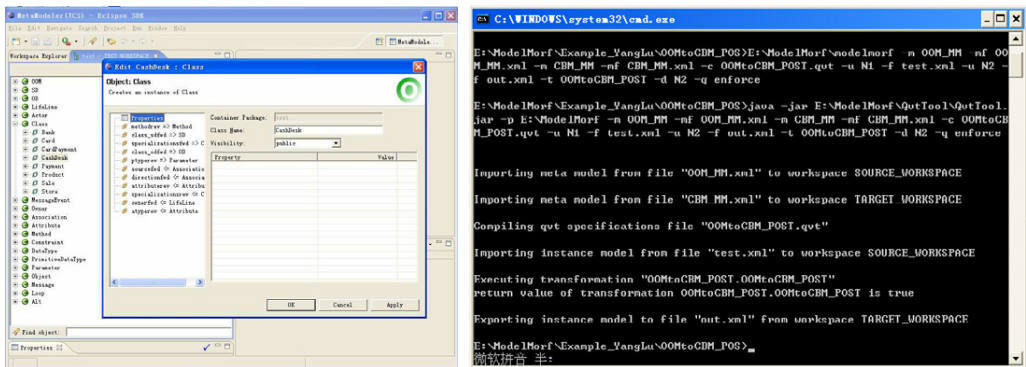

Fig. 9. (a) Model Construction and (b) Transformation Execution

#### 4.2 Implementation of the transformation for refinement rules

After the requirement capture and analysis, the logical design is needed by applying object-oriented refinement to the requirement model, e.g. decomposing the classes in the conceptual class diagrams. We have carried out the implementation of the refinement rule *class decomposition pattern* in QVT [29] and improve it in this paper, and we will implement other important refinement rules, especially the *expert pattern* that are used to decompose the functionality of the methods by delegating responsibilities to the inner classes. The design decisions are needed for the *class decomposition pattern* and the *expert pattern*, and this kind of patterns can be implemented as semi-automatic QVT transformations. These design decisions are made by the designer. More simple transformations, e.g. the *attribute encapsulation pattern*, can be executed automatically without too many design decisions.

**Example 4.1** During an object-oriented design, we often need to decompose a class into a number of classes. For example, consider classes  $C_1 :: D\ a_1$ ,  $C_2 :: D\ a_2$ , and  $D :: T_1\ x, T_2\ y$ . If methods of  $C_1$  only call a method  $D :: m()\{...\}$  that only involves  $x$ , and methods of  $C_2$  only call a method  $D :: n()\{...\}$  that only involves  $y$ , we can decompose  $D$  into two  $D_1 :: T_1\ x; m()\{...\}$  and  $D_2 :: T_2\ y; n()\{...\}$ , and change the type of  $a_1$  in  $C_1$  to  $D_1$  and the type of  $a_2$  in  $C_2$  to  $D_2$ . There are other rules for class decomposition in [16].

We first introduce some notations in rCOS. We use  $N[*supclass, pri, prot, pub, op*]$  to denote a well-formed class declaration that declares the class  $N$  that has *supclass* as its direct superclass; *pri*, *prot* and *pub* as its sets of private, protected and public attributes; and *op* as its set of methods.

**Theorem 4.2 (Class decomposition Pattern)** Assume  $M[*pri, op*]$  is a well-formed class declaration,  $*pri* = \{x, y\}$  are (or are lists of) attributes of  $M$ ,  $m_1()\{c_1(x)\} \in op$  only accesses attribute  $x$ , method  $m_2()\{c_2[m_1]\} \in op$  can only change  $x$  by calling  $m_1$  (or it does not have to change it at all). Then

$$\begin{array}{ll}
 M[*pri_0, op_0*]; Cdecls \sqsubseteq M[*pri_{new}, op_{new}*]; M_1[*pri_1, op_1*]; M_2[*pri_2, op_2*]; Cdecls \\
 *pri_0* = \{x, y\} & *pri_{new}* = \{M_2\ o_2\} \\
 *op_0* = \{m_1()\{c_1(x)\}, & *op_{new}* = \{m_1()\{o_2.m_1()\}, \\
 \quad m_2()\{c_2[m_1()\}\} & \quad m_2()\{o_2.m_2()\}\} \\
 & *pri_1* = \{x\} \\
 & *op_1* = \{m_1()\{c_1(x)\}\} \\
 & *pri_2* = \{y, M_1\ o_1\} \\
 & *op_2* = \{m_1()\{o_1.m_1()\}, \\
 & \quad m_2()\{c_2[o_1.m_1()\}\}
 \end{array}$$

This class decomposition pattern is illustrated in Fig. 10. The class  $M$  in the target model is a part of a more complex model, where  $M$  is connected via interfaces to some class  $C$ . The QVT implementation of this pattern is shown in A.

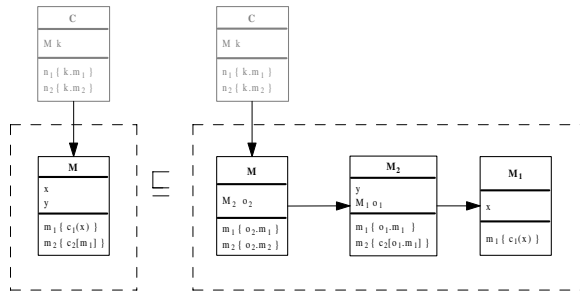

Fig. 10. Class Decomposition Pattern

### 4.3 Implementation of the transformation for component architecture

We have carried out the transformations from the model of logical design to the model of component architecture. For correct construction of the software, such a transformation has to be proved to be a refinement.

In the transformation from the object-oriented model to the component-based architecture, the functionality of the use case will be handled by several components. The decision of functionality decomposition of the use case should be made by the designer. The strategy is mapping **Classes** into **Components** and assigning **Methods** to **Component** or hide them based on the above mapping. The detailed transformation rules are defined in the following.

For the model elements in the *sequence diagram*, we need to consider the transformation of different kinds of entities (messages, loops, alternatives) in different situations:

- (i) The message event is a method invocation between classes that belong to the same component:

This kind of messages in the source domain will not be shown in the component interaction diagram in the target domain.

- (ii) The message event is a method invocation between classes that belong to different components: (cf. the four relations **Message\_to\_Message**)

- (a) While transforming the **Message** in the source domain to the target domain, the **Order Number** of the **Message** is kept. The **agents** of the **lifelines** that send and receive the message will be transformed from the **classes** to the corresponding **components**. If class  $C_{a_1}$  is in component  $C_{o_1}$  and class  $C_{a_2}$  is in component  $C_{o_2}$ ,  $C_{o_1}$  calls  $C_{o_2}$  only when  $C_{a_1}$  calls  $C_{a_2}$ . The **interface** of the component which is the agent of the lifeline will be created.

- (b) The **method** invoked in the source domain will be transformed to the **operation** of the **interface** (in rule a) in the target domain.

- (c) The **attributes** which are used by the **method** (in rule b) should be known by the external environment of the component and will be transformed to the **fields** of the **interface** (in rule a). There **fields** should be attached to the corresponding **operation** (in rule b).

- (d) The (input and output) **parameters** and the **constraints** of the **method** (in rule b) will also be transformed to the **parameters** and the **constraints** of the **operation** (in rule b).

In the situation we separate this step into four QVT relations to satisfy different conditions: the method with input parameters, the method with output parameters, the method with attributes or the method with none of them, to support more complex situations which are combined by the four.

- (iii) The message event is a method invocation from actor to class: (cf. the four relations `Message_to_Message2`)

The transformation rules are similar to these in rule 2 (b - d).

- (a) The sender of the **lifelines** will be transformed from **actors** in the source domain to the target domain, and the receiver of the **lifelines** will be transformed from the **classes** to the corresponding **components**. The **interface** of the **component** will be created.

Quite like the messages in situation i-iii, the **loop** and **alternative** in these different situations have similar transformation rules: the sender and receiver of the loop (or alternative) are transformed, together with a lifeline (or a set of lifelines) that the loop (or alternative) contains (cf. the two relations `Loop_to_Loop` and the two relations `Alternative_to_Alternative`).

For the model elements in the *class diagram* in the source domain, they will be transformed to the corresponding elements in the target domain:

- The **classes** and their **attributes** and **methods** (with the **parameters** and **constraints**) are transformed to the corresponding elements in the target domain directly (cf. the relations `Class_to_Class_and_Component`, `Attribute_to_Attribute`, `InputParameter_to_InputParameter`, `Method_to_Method` and `OutputParameter_to_OutPutParameter`).
- The **specializations** associations between classes will be kept in the target domain (cf. the relation `SuperClass_to_SuperClass`).
- The **associations** between classes in the same component will be transformed to the corresponding elements in the target domain, and the **associations** between classes in different components will not be shown in the target domain. (cf. the relation `Association_to_Association`)

Two relations of the transformation from model of logical design to Model of component architecture are shown in [B](#).

#### 4.3.1 Discussion

For the tool support of this correctness preserving transformations, at first we choose one of the transformations which is proved to be correct using rCOS and implemented using QVT. Then we import a source model which will be transformed and parameterize the transformation based on the design decisions. Finally this transformation will be executed.

- (i) While creating model elements, we want to ensure that duplicate instances are

not created when the required elements already exist. In such case we just want to update the existing ones. The concept of *Key* in QVT, that defines a set of properties of a class that uniquely identify an instance of the class in a model, is used in the transformation. A class may have multiple keys. For example, the key of `method` should be the `name` of the method, the `class` that it belongs to and the `input parameters`. But the multiple keys are not supported by the QVT engine we use now, we only use `name` of the method as the key, so do other model elements.

- (ii) Transformations may be *unidirectional* or *bidirectional*. In a unidirectional transformation, changes must be propagated from the source model to the target model. In a bidirectional transformation, changes must be propagated in either direction. In some cases, changes may be made to both models. Our implementation is a unidirectional transformation which does not work backwards.
- (iii) For some transformations, such as class decomposition pattern, the design decisions are needed and the transformation will not be a fully automatic process. If the interaction between the designer and the QVT tool is possible, the designer can provide design decisions for the transformation. There are two parts of the QVT transformation, one containing the transformation rules executed automatically, another introducing the design decisions made by the designer (cf. the query `QClassToComponent`).
- (iv) Quite often, the functionality of a use case is handled by a number of components. The component decomposition task is needed in this situation, e.g. the use case *Process Sale* is partitioned to four components. But there are also situations that we need to combine the functionality of several use cases for a component. The component composition task is needed here, e.g. some of the functions of the use cases *Process Sale*, *Order Products*, *Change Price* and *Show Report* are used to complete the interfaces of the component *Inventory*. These different situations make the transformation more complex.
- (v) The proof of the correctness of the transformation is missing now. For example, the semantics of the sequence diagram and the component interaction diagram are protocol in terms of a set of traces. We can use verification tools such as FDR [22] to check the consistency of the traces before and after the transformation, or we can prove the consistency (correctness property of the transformation) directly.

## 5 Conclusion and Future Work

This article discusses the practical aspects of transformation from the object-oriented design to the component-based design. By using MOF/QVT framework for implementing model transformations, we hope to be able to tie the knot between formal methods and tool support in the long term. We plan to use formal reasoning to prove the correctness of transformations that are implemented in QVT, that

is, investigate how sequences of atomic transformations modify or preserve already proved properties on a more abstract level.

We have done the experiment using QVT/MOF framework to develop a semi-automatic correctness preserving transformation tool in the whole software development process. We believe this correctness preserving transformation approach would be applicable to a wide range of models. Therefore, we would like to embed them in an existing successful transformation tool, such as MasterCraft [24], to have extensive coverage of the whole software development life-cycle following the idea of Rushby’s toolbus [23].

There is indeed room for further work. We have found the following main areas:

- (i) We propose to implement the OVT transformation for all the rCOS refinement rules, especially the *expert pattern* which is quite often used in the object-oriented design. If we implement a group of automatic transformations, the work will be more useful. This makes it possible to reuse the transformation with only proving its correctness once.

**Theorem 5.1 (Expert Pattern)** *Given a list of class declarations  $Classes$  and its navigation paths  $r_1 \dots r_f.x$  (denoted by  $le$ ),  $\{a_{11} \dots a_{1k_1}.x_1, \dots, a_{\ell 1} \dots a_{\ell k_\ell}.x_\ell\}$ , and  $\{b_{11} \dots b_{1j_1}.y_1, \dots, b_{t1} \dots b_{tj_t}.y_t\}$  starting from class  $C$ , let  $m()$  be a method of  $C$  specified as*

$$C :: m() \{ \quad c(a_{11} \dots a_{1k_1}.x_1, \dots, a_{\ell 1} \dots a_{\ell k_\ell}.x_\ell) \\ \wedge le' = e(b_{11} \dots b_{1s_1}.y_1, \dots, b_{ts_1} \dots b_{ts_t}.y_t) \}$$

*Then  $Classes$  can be refined by redefining  $m()$  in  $C$  and defining the following fresh methods in the corresponding classes:*

$$\begin{aligned} C :: & \quad check() \{ return' = c(a_{11}.get_{\pi_{a_{11}}} x_1(), \dots, a_{\ell 1}.get_{\pi_{a_{\ell 1}}} x_\ell()) \} \\ & \quad m() \{ \text{if } check() \text{ then } r_1.do\text{-}m_{\pi_{r_1}}(b_{11}.get_{\pi_{b_{11}}} y_1(), \dots, b_{s_1}.get_{\pi_{b_{s_1}}} y_s()) \} \\ T(a_{ij}) :: & \quad get_{\pi_{a_{ij}}} x_i() \{ return' = a_{ij+1}.get_{\pi_{a_{ij+1}}} x_i() \} \quad (i : 1..l, j : 1..k_i - 1) \\ T(a_{ik_i}) :: & \quad get_{\pi_{a_{ik_i}}} x_i() \{ return' = x_i \} \quad (i : 1..l) \\ T(r_i) :: & \quad do\text{-}m_{\pi_{r_i}}(d_{11}, \dots, d_{s_1}) \{ r_{i+1}.do\text{-}m_{\pi_{r_{i+1}}}(d_{11}, \dots, d_{s_1}) \} \quad i : 1..f - 1 \\ T(r_f) :: & \quad do\text{-}m_{\pi_{r_f}}(d_{11}, \dots, d_{s_1}) \{ x' = e(d_{11}, \dots, d_{s_1}) \} \\ T(b_{ij}) :: & \quad get_{\pi_{b_{ij}}} y_i() \{ return' = b_{ij+1}.get_{\pi_{b_{ij+1}}} y_i() \} \quad (i : 1..t, j : 1..s_i - 1) \\ T(b_{is_i}) :: & \quad get_{\pi_{b_{is_i}}} y_i() \{ return' = y_i \} \quad (i : 1..t) \end{aligned}$$

*where  $T(a)$  is the type name of attribute  $a$  and  $\pi_{v_i}$  denotes the remainder of the corresponding navigation path  $v$  starting at position  $j$ .*

If the paths  $\{a_{11} \dots a_{1k_1}.x_1, \dots, a_{\ell 1} \dots a_{\ell k_\ell}.x_\ell\}$  have a common prefix, say up to  $a_{1j}$ , then class  $C$  can directly delegate the responsibility of getting the  $x$ -attributes and checking the condition to  $T(a_{ij})$  via the path  $a_{11} \dots, a_{ij}$  and then follow the above rule from  $T(a_{ij})$ . The same rule can be applied to the  $b$ -navigation paths.

- (ii) We propose to model the expressions in command, pre- and post-conditions in metamodel based on the syntax of rCOS:
- (iii) State diagram is also an important view of the system and we will model the metamodel of the state diagram, as shown in Fig. 11.

$T$	::= $M \mid \mathbf{int} \mid \mathbf{bool} \mid \mathbf{double} \mid \dots$	<i>type</i>
$V$	::= $x \mid V' \mid \mathbf{this} \mid \mathbf{null} \mid n \mid \mathbf{true} \mid \mathbf{false} \mid \dots$	<i>variable</i>
$E$	::= $V \mid E.m \mid E.f(\overline{E}) \mid ((M)E) \mid M.\mathbf{new}(\overline{E}) \mid B$ $\mid (E_1 + E_2) \mid (E_1 - E_2) \mid (E_1 * E_2) \mid (E_1/E_2) \mid \dots$	<i>expression</i>
$B$	::= $(E_1 == E_2) \mid (E_1 < E_2) \mid \neg B \mid (B_1 \wedge B_2)$ $\mid (\forall V \bullet B) \mid (E \text{ is } M)$	<i>boolean expression</i>
$C$	::= $\mathbf{var } T \ x \ [= E] \mid \mathbf{end } x \mid \mathbf{skip} \mid \mathbf{chaos}$ $\mid (V := E) \mid (E_1.m := E_2) \mid E.f(\overline{E}; \overline{V})$ $\mid (C_1; C_2) \mid C_1 \triangleleft B \triangleright C_2 \mid B * C$ $\mid (C_1 \sqcap C_2) \mid (C_1 \wedge C_2)$	<i>command</i>
...		

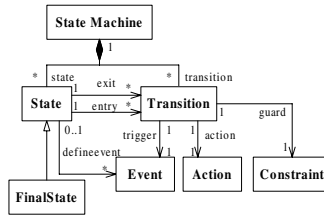

Fig. 11. Metamodel for the state diagram

A state diagram specifies the behavioral patterns of the classes and the functionalities of method invocations. A state diagram consists of *states* and *transitions*. A transition from a state is either one of the methods of classes or triggered by external invocations. A transition may have a trigger event and an action with the guard:

- A *trigger event* is a method signature.
- An *action* is a rCOS command.
- A *guard* is a predicate about the attributes of the class and local variables in action.

## Acknowledgement

I would like to thank Zhiming Liu and Volker Stolz from UNU-IIST for their discussions and useful comments for the paper. This work is partially supported by the project HighQSoftD funded by Macao Science and Technology Development Fund and the National Grand Fundamental Research 973 Program of China (No. 2002CB312001).

## References

- [1] Kent Modelling Framework. <http://www.cs.kent.ac.uk/projects/kmf/>, 2004.
- [2] A. Agrawal. Graph Rewriting And Transformation (GReAT): A Solution For The Model Integrated Computing (MIC) Bottleneck. In *ASE*, pages 364–368, 2003.
- [3] J. Bézivin, G. Dupé, F. Jouault, and J. E. Rougui. First experiments with the ATL model transformation language: Transforming XSLT into XQuery. In *Online Proceedings of the OOPSLA'03 Workshop on Generative Techniques in the Context of the MDA*, 2003.



- [4] X. Chen, J. He, Z. Liu, and N. Zhan. A Model of Component-Based Programing. In *International Symposium on Fundamentals of Software Engineering, to appear in LNCS*. Springer, 2007.
- [5] X. Chen, Z. Liu, and V. Mencl. Separation of Concerns and Consistent Integration in Requirements Modelling. In *Proceedings of 33rd International Conference on Current Trends in Theory and Practice of Computer Science (SOFSEM 07)*, LNCS 4362. Springer, 2007.
- [6] Z. Chen, A.H. Hannousse, D. Van Hung, I. Knoll, X. Li, Y. Liu, Z. Liu, Q. Nan, J. Okika, A.P. Ravn, V. Stolz, L. Yang, and N. Zhan. The Common Component Modelling Example in rCOS. In *The Common Component Modeling Example: Comparing Software Component Models*. Springer, 2007. To be published as LCNS.
- [7] K. Czarnecki and S. Helsen. Classification of Model Transformation Approaches. In *Proceedings of OOPSLA 2003 Workshop: Generative techniques in the context of MDA*, 2003.
- [8] J. de Lara and H. Vangheluwe. AToM<sup>3</sup>: A Tool for Multi-formalism and Meta-modelling. In *Proceedings of FASE 2002*, pages 174–188, 2002.
- [9] J. de Lara and H. Vangheluwe. Using AToM<sup>3</sup> as a Meta-Case Tool. In *Proceedings of ICEIS 2002*, pages 642–649, 2002.
- [10] Object Management Group. Technical Guide to Model Driven Architecture: The MDA Guide, version 1.0.1. <http://www.omg.org/cgi-bin/doc?omg/03-06-01>, OMG Document: omg/2003-06-01, 2003.
- [11] Object Management Group. Meta Object Facility (MOF) 2.0 XMI Mapping Specification, version 2.1. <http://www.omg.org/uml/>, OMG document: formal/05-09-01, 2005.
- [12] Object Management Group. MOF QVT final adopted specification. <http://www.omg.org/docs/ptc/05-11-01.pdf>, OMG Document:ptc/05-11-01, 2005.
- [13] Object Management Group. Unified Modeling Language: Superstructure, version 2.0, final adopted specification. <http://www.omg.org/uml/>, OMG Document: formal/05-07-04, 2005.
- [14] Object Management Group. Meta Object Facility, version 2.0. <http://www.omg.org/cgi-bin/doc?formal/2006-01-01>, OMG document: formal/2006-01-01, 2006.
- [15] Object Management Group. Object Constraint Language Specification, version 2.0. OMG document: formal/06-05-01, 2006.
- [16] J. He, X. Li, and Z. Liu. rCOS: A refinement calculus for object systems. *Theoretical Computer Science*, 365(1-2):109–142, 2006.
- [17] C.A.R. Hoare and J. He. *Unifying Theories of Programming*. Prentice-Hall, 1998.
- [18] C. Larman. *Applying UML and Patterns*. Prentice-Hall Intl., 3rd edition, 2005.
- [19] G.T. Leavens, A.L. Baker, and C. Ruby. Preliminary Design of JML: A Behavioral Interface Specification Language for Java. Technical Report 98-06-rev29, Department of Computer Science, Iowa State University, USA., January 2006.
- [20] F. Marschall and P. Braun. Model Transformations for the MDA with BOTL. In A. Rensink, editor, *Proceedings of the Workshop on Model Driven Architecture: Foundations and Applications*, pages 25–36, 2003.
- [21] O. Patrascoiu. YATL: Yet Another Transformation Language. In *Proceedings of First European Workshop MDA-IA*, 2004.
- [22] A.W. Roscoe. *The Theory and Practice of Concurrency*. Prentice Hall, 1997.
- [23] J.M. Rushby. An Evidential Tool Bus. In *Proceedings of ICFEM 2005*, pages 36–36, 2005.
- [24] Tata Consultancy Services. MasterCraft. <http://www.tata-mastercraft.com/>.
- [25] Tata Consultancy Services. ModelMorf. <http://www.tcs-trddc.com/modelmorf/>.
- [26] INRIA Atlas team. ATL engine. <http://modelware.inria.fr/rubrique12.html>, 2003.
- [27] D. Varro, G. Varro, and A. Pataricza. Designing the Automatic Transformation of Visual Languages. *Science of Computer Programming*, 44(2):205–227, 2002.
- [28] E. D. Willink. UMLX: A graphical transformation language for MDA. In A. Rensink, editor, *Proceedings of the Workshop on Model Driven Architecture: Foundations and Applications*, pages 13–24, 2003.
- [29] L. Yang, V. Mencl, V. Stolz, and Z. Liu. Automating Correctness Preserving Model-to-Model Transformation in MDA. In *Draft Proceedings of the 1st Asian Working Conference on Verified Software, AWCVS'06*, UNU-IIST Report No. 348, 2006. <http://www.iist.unu.edu>.

## A Appendix: The QVT Implementation of the Class Decomposition Pattern

In the following we give the working source code of the Class Decomposition Pattern we used to implement the transformation in the ModelMorf QVT tool.

**transformation** ClassDecomposition(N1:ObjectUML;N2:ObjectUML)

```
{
  key ObjectUML::Class{name};
  key ObjectUML::Attribute{name};
  key ObjectUML::Operation{name};
  key ObjectUML::DataType{name};
  key ObjectUML::PrimitiveDataType{name};

  top relation ClassDecomp{
    x,c1:String;

    checkonly domain N1
    c:Class{
      name = 'M',
      attributerev = att:Attribute{
        name = x,
        isPrimitive = true
      },
      operationrev = o_1:Operation{
        name = 'm1',
        commandrev = cmd_1:Command{
          cmd = c1,
          parameterrev = att
        }
      },
      operationrev = o_2:Operation{
        name = 'm2',
        commandrev = cmd_2:Command{ cmd = 'm1' }
      }
    }
  };

  enforce domain N2
  c_0:Class{
    name = 'M',

    sourcefwd = asso_2:Association{
      directionrev = c_2:Class{
        name = 'M2',

        sourcefwd = asso_1:Association{
          directionrev = c_1:Class {
            name = 'M1',
            attributerev = att_1:Attribute{
              name = x,
              isPrimitive = true
            },
          },
          operationrev = oper_1:Operation{
            name = 'm1_1',
            ovisibility = 'public',
            commandrev = cmd_1_1:Command{
              cmd = c1,
              parameterrev = att_1
            }
          }
        }
      }
    }
  },
  attributerev = attr_2:Attribute{
    name = 'o1',
    isPrimitive = false,
    atypefwd = c_1
  },
  operationrev = o_2_1:Operation{
    name = 'm1_2',
```

```

        commandrev = cmd_2_1:Command{ cmd = 'o1.m1_1' }
    },
    operationrev = o_2_2:Operation {
        name = 'm2_2',
        commandrev = cmd_2_2:Command{ cmd = 'o1.m1_1' }
    }},
    attributerev = attr_0:Attribute{
        name = 'o2',
        isPrimitive = false,
        atypefwd = c_2
    },
    operationrev = o_0_1:Operation{
        name = 'm1',
        commandrev = cmd_0_1:Command{ cmd = 'o2.m1_1' }
    },
    operationrev = o_0_2:Operation {
        name = 'm2',
        commandrev = cmd_0_2:Command{ cmd = 'o2.m2_2' }
    }
};
}
}

```

## B Appendix: The QVT Implementation of the Relations in OOtCB

In the following we give part of the working source code of the OOtCB transformation: relations `Message_to_Message` and `Association_to_Association`.

```

top relation Message_to_Message_with_Input_Parameter {
    mname,inname,outname,ename,oname,linname,loutname,prname,
    prename,postname,pname,tname,prec,postc:String;
    o:Integer;

```

**checkonly domain** N1

```

message_1:Message{
    order = o,
    senderfwd = l_in_1:LifeLine{
        ownerrev = ca_in_1:Class{}
    },
    receiverfwd = l_out_1:LifeLine{
        ownerrev = ca_out_1:Class{}
    },
    eventfwd = msgevent_1:MessageEvent{
        name = ename,
        operationcalledfwd = m_1:Method{
            name = oname,
            in_parameterrev = in_parameter_1:Parameter{
                name = pname,
                ptypefwd = type_in_1:DataType
                {name = tname}
            },
            preconditionfwd = pre_1:Constraint{
                name = prename,
                condition = prec
            },
            postconditionfwd = post_1:Constraint{
                name = postname,
                condition = postc
            }
        }
    }
}
}}}{QClassToComponent(ca_in_1) <> QClassToComponent(ca_out_1)};

```

**enforce domain** N2

```

message_2:Message {
    name = mname,

```

```

order = o,
senderfwd = l_in_2:LifeLine{
  name = linname,
  ownerrev = co_in_2:Component
  {name = inname}
},
receiverfwd = l_out_2:LifeLine{
  name = loutname,
  ownerrev = co_out_2:Component{
  name = outname,
  providedrev = pro_interface:Interface
  {name = proname}
}},
eventfwd = msgevent_2:MessageEvent{
  name = ename,
  operationcalledfwd = m_2:Operation{
  name = oname,
  operationfwd = pro_interface,
  in_parameterrev = in_parameter_2:O_Parameter{
  name = pname,
  co_ptypefwd = type_in2:DataType
  {name = tname}
  },
  co_preconditionfwd = pre_2:O_Constraint{
  name = prename,
  o_condition = prec
  },
  co_postconditionfwd = post_2:O_Constraint{
  name = postname,
  o_condition = postc
  }}}};

where {
  inname = QClassToComponent(ca_in_1);
  outname = QClassToComponent(ca_out_1);
  mname = message_1.name.substring(1,message_1.name.size()-ename.size()-1).concat('.')+ename;
  linname = l_in_1.name.substring(1,l_in_1.name.size()-ca_in_1.name.size()).concat(inname);
  loutname = l_out_1.name.substring(1,l_out_1.name.size()-ca_out_1.name.size()).concat(outname);
  proname = outname + '_provided_interface';
}}

top relation Association_to_Association {
  aname,sname,tname:String;

checkonly domain N1
association_1:Association{
  name = aname,
  sourcev = class_1:Class{name = sname},
  directionrev = dclass_1:Class{name = tname}
}{QClassToComponent(association_1.sourcev) = QClassToComponent(association_1.directionrev)};

enforce domain N2
association_2:Association {
  name = aname,
  sourcev = class_2:Class{name = sname},
  directionrev = dclass_2:Class{name = tname}
};
}

```