

Galois Theory for Braided Tensor Categories and the Modular Closure

Michael Müger^{1,2}

*Dipartimento di Matematica, Università di Roma “Tor Vergata”,
Via della Ricerca Scientifica, 00133 Rome, Italy*
E-mail: mueger@axp.mat.uniroma2.it

Received March 1, 1999; accepted March 1, 1999

Given a braided tensor $*$ -category \mathcal{C} with conjugate (dual) objects and irreducible unit together with a full symmetric subcategory \mathcal{S} we define a crossed product $\mathcal{C} \rtimes \mathcal{S}$. This construction yields a tensor $*$ -category with conjugates and an

[View metadata, citation and similar papers at core.ac.uk](#)

categories sitting between \mathcal{C} and $\mathcal{C} \rtimes \mathcal{S}$ and closed subgroups of the Galois group $\text{Gal}(\mathcal{C} \rtimes \mathcal{S} / \mathcal{C}) = \text{Aut}_{\mathcal{C}}(\mathcal{C} \rtimes \mathcal{S})$ of \mathcal{C} , the latter being isomorphic to the compact group associated with \mathcal{S} by the duality theorem of Doplicher and Roberts. Denoting by $\mathcal{D} \subset \mathcal{C}$ the full subcategory of degenerate objects, i.e., objects which have trivial monodromy with all objects of \mathcal{C} , the braiding of \mathcal{C} extends to a braiding of $\mathcal{C} \rtimes \mathcal{S}$ iff $\mathcal{S} \subset \mathcal{D}$. Under this condition, $\mathcal{C} \rtimes \mathcal{S}$ has no non-trivial degenerate objects iff $\mathcal{S} = \mathcal{D}$. If the original category \mathcal{C} is rational (i.e., has only finitely many isomorphism classes of irreducible objects) then the same holds for the new one. The category $\overline{\mathcal{C}} \equiv \mathcal{C} \rtimes \mathcal{D}$ is called the *modular closure* of \mathcal{C} since in the rational case it is modular, i.e., gives rise to a unitary representation of the modular group $SL(2, \mathbb{Z})$. If all simple objects of \mathcal{S} have dimension one the structure of the category $\mathcal{C} \rtimes \mathcal{S}$ can be clarified quite explicitly in terms of group cohomology.

© 2000 Academic Press

1. INTRODUCTION

Since in this paper we are concerned with symmetric and braided tensor (or monoidal) categories [20] it may be useful to sketch the origin of some of the pertinent ideas. Symmetric tensor categories were formalized in the early sixties, but they are implicit in the earlier Tannaka–Krein duality theory for compact groups. Further motivation for their analysis came from Grothendieck’s theory of motives and led to Saavedra Rivano’s work [28], which was corrected and extended in [4]. These formalisms reconstruct a group (compact topological in the first, algebraic in the

¹ Supported by EU TMR Network “Noncommutative Geometry.”

² Present address: Institut de Recherche Mathématique Avancée, Université Louis Pasteur, Strasbourg, France.

second case) from the category of its representations, the latter being *concrete*, i.e., consisting of vector (Hilbert) spaces and linear maps between these.

In the operator algebraic approach to quantum field theory it was realized around 1970 that the category of localized superselection sectors (\cong physically relevant representations of the C^* -algebra \mathcal{A} of observables) is symmetric monoidal, cf. [26]. This category being a category of endomorphisms of \mathcal{A} —not of vector spaces—the existing duality theorems did not apply. This led Doplicher and Roberts to develop their characterization [6] of representation categories of compact groups as *abstract* symmetric tensor categories satisfying certain additional axioms. This result allowed the solution [7] of the longstanding problem of (re-)constructing a net of charged field algebras \mathcal{F} which intertwine the inequivalent representations of \mathcal{A} and have nice properties like Bose–Fermi commutation relations. (In fact, *assuming* the duality theorem for abstract symmetric categories such a reconstruction result existed much earlier [25].) At the same time and independently Deligne extended [5] the earlier works [28, 4] by identifying a necessary and sufficient condition for an abstract symmetric tensor category to be the representation category of an algebraic group. The crucial property is that all objects in the given category have integer dimension. (For symmetric C^* -tensor categories this is automatic [6, Corollary 2.15] as a consequence of Hilbert space positivity.)

Braided tensor categories without the symmetry requirement entered the scene only in the eighties. From a theoretical point of view braided tensor categories are most naturally “explained” by identifying [14] them as 2-categories with tensor product and only one object, which in turn are just 3-categories with only one object and one 1-morphism. (All these notions are easiest to deal with in the strict case, which for (symmetric, braided) tensor categories does not imply a loss of generality in view of the coherence theorems [20, 14].) But the main reason for their recent prominence is their relation to certain algebraic structures arising in physics (Yang–Baxter equation, quantum groups) and to topological invariants of knots, links, and 3-manifolds. The latter subject was boosted by V. Jones’ construction of a new knot invariant which was soon discovered to be related to the quantum group $SU_q(2)$ where q is a root of unity, and subsequently invariants of 3-manifolds were constructed for all quantum groups at roots of unity. The theory reached a certain state of maturity when it was understood that the crucial ingredient underlying these invariants of 3-manifolds is a certain class of braided tensor categories which are called modular [29]. A modular category is a braided tensor category which (i) has a twist [29] or balancing [14], (ii) is rational—i.e., has only finitely many isomorphism classes of irreducible objects—and (iii) is non-degenerate. Here non-degeneracy means that an

irreducible object ρ for which $\varepsilon(\rho, \sigma) \circ \varepsilon(\sigma, \rho) = \text{id}_{\sigma\rho} \forall \sigma$ is equivalent to the unit object ι . (The designation of such categories as modular is owed to the fact that they give rise to a finite dimensional representation of the modular group $SL(2, \mathbb{Z})$ [29]; see also [23].) The role of the quantum groups then reduces just to providing several infinite families of modular categories (roughly, one for every pair (root of unity, classical Lie algebra)). Another construction of modular categories starts from link invariants, cf. [29, Chap. XII; 30]. Finally, braided tensor categories appear naturally also in the superselection theory of quantum field theories in low dimensional spacetimes, cf., e.g., [17]. In many cases, as for the WZW and orbifold models, these categories actually turn out to be modular. Let \mathcal{A} be a quantum field theory in $1 + 1$ dimensions and let \mathcal{C} be the braided category of superselection sectors with finite statistics. Since the full subcategory $\mathcal{D} \subset \mathcal{C}$ of degenerate sectors is symmetric, the Doplicher–Roberts construction can be applied to \mathcal{A} and \mathcal{D} and yields new theory \mathcal{F} . In [23] Rehren conjectured that the representation category of \mathcal{F} is nondegenerate. Under the assumption that \mathcal{A} has only finitely many irreducible degenerate sectors this was proved by the author in [21]. The aim of the present paper is to give a purely categorical analogue of this construction (without the finiteness restriction).

More precisely, given a braided tensor category \mathcal{C} which is enriched over $\text{Vect}_{\mathbb{C}}$, has a positive $*$ -operation, conjugate (dual) objects, direct sums and subobjects, and an irreducible unit object together with a symmetric subcategory \mathcal{S} satisfying the same properties, we define a crossed product $\mathcal{C} \rtimes \mathcal{S}$. (The existence of direct sums and subobjects (in the sense of [10]) is no serious restriction since it can always be achieved by embedding the category in a bigger one [19, Appendix].) This construction proceeds in two steps. First we define a tensor category $\mathcal{C} \rtimes_0 \mathcal{S}$ which has the same objects and tensor product as \mathcal{C} but bigger spaces of arrows, i.e.,

$$\text{Hom}_{\mathcal{C} \rtimes_0 \mathcal{S}}(\rho, \sigma) \supset \text{Hom}_{\mathcal{C}}(\rho, \sigma) \quad \forall \rho, \sigma \in \mathcal{C}. \quad (1.1)$$

Of course, we have to prove that $\mathcal{C} \rtimes_0 \mathcal{S}$ satisfies all axioms of a tensor $*$ -category. The new category inherits the braiding ε from \mathcal{C} iff \mathcal{S} contains only degenerate objects, thus iff $\mathcal{S} \subset \mathcal{D}$ where $\mathcal{D} \subset \mathcal{C}$ is the full subcategory of degenerate objects as above. (If this condition is not fulfilled naturality of ε fails for some of the new morphisms of $\mathcal{C} \rtimes_0 \mathcal{S}$.) Now, $\mathcal{C} \rtimes_0 \mathcal{S}$ will be closed under direct sums, but usually not under subobjects. Thus we apply the abovementioned procedure of [19] in order to obtain a category $\mathcal{C} \rtimes \mathcal{S}$ which is closed under direct sums and subobjects. Then the braiding of $\mathcal{C} \rtimes_0 \mathcal{S}$ —if it exists—extends to $\mathcal{C} \rtimes \mathcal{S}$. The result of this construction is again a tensor category with positive $*$ -operation and conjugates, direct sums, subobjects, and irreducible unit. $\mathcal{C} \rtimes \mathcal{S}$ is braided if $\mathcal{S} \subset \mathcal{D}$. Under

this condition we prove that $\mathcal{C} \rtimes \mathcal{S}$ has no degenerate objects iff $\mathcal{S} = \mathcal{D}$. The category $\overline{\mathcal{C}} = \mathcal{C} \rtimes \mathcal{S}$ is called the *modular closure* of \mathcal{C} since in the rational case (where there are only finitely many isomorphism classes of irreducible objects) it is modular. (In particular, $\overline{\mathcal{C}}$ is rational if \mathcal{C} is.) The modular closure $\overline{\mathcal{C}}$ is non-trivial, i.e., has irreducible objects which are not equivalent to the unit, iff \mathcal{C} is not symmetric, thus not completely degenerate. Define the absolute Galois group $\text{Gal}(\mathcal{C})$ of a braided tensor category \mathcal{C} to be the compact group associated to the symmetric tensor category $\mathcal{D}(\mathcal{C})$ by the duality theorem of Doplicher and Roberts. For every symmetric category $\mathcal{S} \subset \mathcal{C}$ we establish a Galois correspondence between subcategories \mathcal{E} of $\mathcal{C} \rtimes \mathcal{S}$ containing \mathcal{C} and closed subgroups H of the relative Galois group $G = \text{Aut}_{\mathcal{C}}(\mathcal{C} \rtimes \mathcal{S}) \cong \text{Gal}(\mathcal{S})$, given by $\mathcal{E} = (\mathcal{C} \rtimes \mathcal{S})^H$ and $H = \text{Aut}_{\mathcal{E}}(\mathcal{C} \rtimes \mathcal{S})$. The normal subgroups H correspond to the subextensions $\mathcal{C} \rtimes \mathcal{T}$ where $\mathcal{T} \subset \mathcal{S}$ and $\text{Gal}(\mathcal{T}) \cong G/H$. If $\mathcal{S} \subset \mathcal{D}$ then $\mathcal{C} \rtimes \mathcal{S}$ is a braided subextension of $\overline{\mathcal{C}} = \mathcal{C} \rtimes \mathcal{D}$, the absolute Galois group $\text{Gal}(\mathcal{C} \rtimes \mathcal{S})$ being isomorphic to $H = \text{Aut}_{\mathcal{C} \rtimes \mathcal{S}}(\overline{\mathcal{C}})$. Giving an explicit description of the (isomorphism classes of) irreducible objects of $\mathcal{C} \rtimes \mathcal{S}$ is difficult in general, but if all irreducible objects of \mathcal{S} have dimension one, corresponding to abelian $\text{Gal}(\mathcal{S})$, the structure of the category $\mathcal{C} \rtimes \mathcal{S}$ can be clarified quite explicitly in terms of group cohomology.

We briefly describe the organization of the paper. In Section 2 we give precise definitions and several preparatory results on braided C^* -tensor categories. In particular we prove that they are automatically ribbon categories, i.e., have a twist. In Section 3 the crossed product $\mathcal{C} \rtimes \mathcal{S}$ is defined and proved to be a C^* -tensor category. Then, in Section 4 we prove that $\mathcal{C} \rtimes \mathcal{D}$ is non-degenerate and establish the Galois correspondence. In Section 5 we enlarge on abelian extensions, the case of supergroups, and make some further remarks on the case $\mathcal{S} \not\subset \mathcal{D}$.

2. DEFINITIONS AND PREPARATIONS

2.1. Some Results on C^* -Tensor Categories

We begin by establishing our notation concerning tensor categories. Objects will be denoted by small Greek letters ρ, σ , etc. The set of arrows (morphisms) between ρ and σ in the category \mathcal{C} is $\text{Hom}_{\mathcal{C}}(\rho, \sigma)$, where the subscript \mathcal{C} is omitted when there is no danger of confusion. The identity arrow of ρ is id_{ρ} , and composition of arrows is denoted by \circ . The tensor product $\rho \otimes \sigma$ of objects will be abbreviated by $\rho\sigma$. All tensor categories in this paper are supposed small and strict, thus when we mention these conditions it is only for emphasis. (A tensor category is strict if the tensor product satisfies associativity $\rho(\sigma\eta) = (\rho\sigma)\eta$ “on the nose” and

there is a unit object ι satisfying $\rho\iota = \iota\rho = \rho \forall \rho$.) Given two arrows $R \in \text{Hom}(\rho, \sigma)$, $R' \in \text{Hom}(\rho', \sigma')$ there is an arrow $R \times R' \in \text{Hom}(\rho\rho', \sigma\sigma')$. The mapping $(R, R') \mapsto R \times R'$ is associative, satisfies $\text{id}_\iota \times R = R \times \text{id}_\iota = R$, and the interchange law

$$(S \circ R) \times (S' \circ R') = S \times S' \circ R \times R' \quad (2.1)$$

if $S \in \text{Hom}(\sigma, \tau)$, $S' \in \text{Hom}(\sigma', \tau')$. A tensor category \mathcal{C} is braided if there is a family of invertible arrows $\{\varepsilon(\rho, \sigma) \in \text{Hom}(\rho\sigma, \sigma\rho), \rho, \sigma \in \mathcal{C}\}$, natural in both variables and satisfying

$$\varepsilon(\rho, \sigma_1\sigma_2) = \text{id}_{\sigma_1} \times \varepsilon(\rho, \sigma_2) \circ \varepsilon(\rho, \sigma_1) \times \text{id}_{\sigma_2}, \quad (2.2)$$

$$\varepsilon(\rho_1\rho_2, \sigma) = \varepsilon(\rho_1, \sigma) \times \text{id}_{\rho_2} \circ \text{id}_{\rho_1} \times \varepsilon(\rho_2, \sigma) \quad (2.3)$$

for all ρ_i, σ_i . A braided tensor category is symmetric if the braiding satisfies $\varepsilon(\rho, \sigma) \circ \varepsilon(\sigma, \rho) = \text{id}_{\sigma\rho} \forall \rho, \sigma$.

All categories in this paper will be enriched over $\text{Vect}_{\mathbb{C}}$, but we do not presuppose familiarity with this notion. A *complex tensor category* is a tensor category, for which the sets $\text{Hom}(\rho, \sigma)$ of arrows are complex vector spaces and the composition \circ and tensor product \times of arrows are bilinear. A $*$ -operation on a complex tensor category is a map which assigns to an arrow $X \in \text{Hom}(\rho, \sigma)$ another arrow $X^* \in \text{Hom}(\sigma, \rho)$. This map has to be antilinear, involutive ($X^{**} = X$), contravariant ($((S \circ T)^* = T^* \circ S^*)$), and monoidal ($((S \times T)^* = S^* \times T^*)$). A $*$ -operation is *positive* iff $X^* \circ X = 0$ implies $X = 0$. A *tensor $*$ -category* is a complex tensor category with a positive $*$ -operation. For such categories we admit only unitary braidings.

An object ρ is called irreducible or simple if $\text{Hom}(\rho, \rho) = \mathbb{C} \text{id}_\rho$. As usual, two objects ρ, σ are equivalent (or isomorphic) iff $\text{Hom}(\sigma, \rho)$ contains an invertible arrow. In W^* -categories $\text{Hom}(\sigma, \rho)$ then contains a unitary by polar decomposition of morphisms [10, Corollary 2.7]. An object σ is a *subobject* of ρ , denoted $\sigma < \rho$, iff $\text{Hom}(\sigma, \rho)$ contains an isometry. Note that this notion of subobjects differs from the standard one of category theory [20], cf. also the remarks in [10, p. 98]. A tensor $*$ -category is closed under subobjects (or, has subobjects) if for every orthogonal projection $E \in \text{Hom}(\rho, \rho)$ there is an object σ and an isometry $V \in \text{Hom}(\sigma, \rho)$ such that $V \circ V^* = E$. A tensor $*$ -category has (finite) *direct sums* iff for every pair ρ_1, ρ_2 there are τ and isometries $V_i \in \text{Hom}(\rho_i, \tau)$ such that $V_1 \circ V_1^* + V_2 \circ V_2^* = \text{id}_\tau$. Then we write $\tau \cong \rho_1 \oplus \rho_2$. Note that every $\tau' \cong \tau$ is a direct sum of ρ_1, ρ_2 , too. A tensor $*$ -category can always canonically be extended to a tensor $*$ -category with direct sums and subobjects [19, Appendix].

From now on all categories are tensor $*$ -categories. In the present setting it is convenient to define conjugate (dual) objects in a way which differs

slightly from the one for rigid (autonomous) tensor categories [14, 29]. We give only the main definitions and facts and refer to [19] for the details. An object $\bar{\rho}$ is said to be conjugate to ρ if there are $R \in \text{Hom}(\iota, \bar{\rho}\rho)$, $\bar{R} \in \text{Hom}(\iota, \rho\bar{\rho})$ satisfying the *conjugate equations*

$$\bar{R}^* \times \text{id}_\rho \circ \text{id}_\rho \times R = \text{id}_\rho, \quad R^* \times \text{id}_{\bar{\rho}} \circ \text{id}_{\bar{\rho}} \times \bar{R} = \text{id}_{\bar{\rho}}. \quad (2.4)$$

A category \mathcal{C} has conjugates if every object $\rho \in \mathcal{C}$ has a conjugate $\bar{\rho} \in \mathcal{C}$. If ρ is irreducible, then an irreducible conjugate $\bar{\rho}$ is unique up to isomorphism and (upon proper normalization of R, \bar{R}) $R^* \circ R = \bar{R}^* \circ \bar{R} \in \text{Hom}(\iota, \iota)$ is independent of the choice of R, \bar{R} . Then the dimension defined via $d(\rho) \text{id}_\iota = R^* \circ R$ is in $[1, \infty)$ and satisfies $d(\rho) = d(\bar{\rho})$. For reducible ρ we admit only *standard solutions* [19] of (2.4). This means that $R_\rho = \sum_i \bar{W}_i \times W_i \circ R_i$ where $\rho \cong \bigoplus_i \rho_i$ is a decomposition into irreducibles effected by the isometries W_i and R_i is (part of) a normalized solution of (2.4) for ρ_i . Then the definition $d(\rho) = R_\rho^* \circ R_\rho$ extends to reducible objects and yields a multiplicative dimension function. (This dimension is subject to the same restriction as the square root of the Jones index of an inclusion of factors, cf. [19]. Note that the braiding does not play a role here, yet the categorical dimension coincides with the q -dimension for representation categories of quantum groups [27].)

The more specific notion of C^* -tensor categories will not be needed explicitly in this paper. But since we wish to make use of results of [10, 6, 19] we will prove that many tensor $*$ -categories are automatically C^* -tensor categories. Now, a C^* -tensor category is a complex tensor category with a $*$ -operation. Furthermore, the spaces $\text{Hom}(\rho, \sigma)$, $\rho, \sigma \in \mathcal{C}$ are Banach spaces and the norms satisfy

$$\|Y \circ X\| \leq \|X\| \|Y\|, \quad (2.5)$$

$$\|X^* \circ X\| = \|X\|^2 \quad (2.6)$$

for $X \in \text{Hom}(\rho, \sigma)$, $Y \in \text{Hom}(\sigma, \eta)$. (Then the algebras $\text{Hom}(\rho, \rho)$, $\rho \in \mathcal{C}$ are C^* -algebras.) See the cited references for examples.

It is known [19] that in a C^* -tensor category with conjugates and an irreducible unit, i.e., $\text{Hom}(\iota, \iota) = \mathbb{C} \text{id}_\iota$, all spaces of arrows are finite dimensional. The following result is a converse, which generalizes a well-known fact on finite dimensional \mathbb{C} -algebras.

PROPOSITION 2.1. *Let \mathcal{C} be a $\text{Vect}_{\mathbb{C}}^{\text{fin}}$ -category, i.e., a category where $\text{Hom}(\rho, \sigma)$ is a finite dimensional \mathbb{C} -vector space for every pair $\rho, \sigma \in \mathcal{C}$, the composition \circ being bilinear. Then \mathcal{C} is a C^* -category iff there is a positive $*$ -operation.*

Proof. If \mathcal{C} is a C^* -category there is a $*$ -operation by definition. Positivity follows from (2.6). Assume conversely the existence of a positive $*$ -operation. In particular, $*$ gives rise to a positive involution on the algebras $\text{Hom}(\rho, \rho)$, $\rho \in \mathcal{C}$. The latter being finite dimensional \mathbb{C} -algebras, this implies semisimplicity and the existence of unique C^* -norms. Now we consider the $*$ -algebras $M(\rho_1, \dots, \rho_n)$ [10, p. 86] associated with n objects (which, roughly speaking, are the algebras generated by the arrows between the objects ρ_1, \dots, ρ_n). For an element $\hat{X} = (X_{ij})$ of $M(\rho_1, \dots, \rho_n)$, $\hat{X}^* \hat{X} = 0$ is equivalent to $X_{ij}^* \circ X_{ij} = 0 \forall i, j = 1, \dots, n$. Since by assumption this holds only if all X_{ij} vanish, the $*$ -involution of $M(\rho_1, \dots, \rho_n)$ is positive and also $M(\rho_1, \dots, \rho_n)$ is a C^* -algebra. Now we define the norm on $\text{Hom}(\rho, \sigma)$ by

$$\|X\| = \sqrt{\|X^* \circ X\|}, \quad X \in \text{Hom}(\rho, \sigma), \quad (2.7)$$

where the norm on the right hand side is the one of $M(\rho, \sigma)$. Since the algebras M form a directed system the norm of $X^* \circ X$ is the same in, say, $M(\rho, \sigma, \eta)$ and thus well defined. As an immediate consequence we have $\|X\| = \|X^*\|$, and the submultiplicativity of the norms

$$\|Y \circ X\| \leq \|X\| \|Y\| \quad (2.8)$$

for $X \in \text{Hom}(\rho, \sigma)$, $Y \in \text{Hom}(\sigma, \eta)$ required of a C^* -category follows from submultiplicativity in $M(\rho, \sigma, \eta)$. The C^* -condition (2.6) follows from the C^* -property of $M(\rho, \sigma)$. ■

Remark. This result is probably well known among experts, but to the best of the author's knowledge it never appeared in print. Yet it is used implicitly in [32] where certain categories are proved to have a positive $*$ -operation and concluded to be C^* -categories.

In the above result we did not assume irreducibility of the unit ι , viz. $\text{Hom}(\iota, \iota) = \mathbb{C} \text{id}_\iota$. From now on all categories in this paper will be assumed to have this property, which has been called connectedness [2]. We will remark on the disconnected case in the outlook.

We summarize the properties of the categories we will study.

DEFINITION 2.2. A TC^* is a small strict tensor $*$ -category with conjugates, direct sums, subobjects, finite dimensional spaces of arrows, and an irreducible unit object. A BTC^* is a TC^* with a unitary braiding. A STC^* is a symmetric BTC^* .

Remark. All concepts in this definition which are not standard category theory are from [10, 6, 19]. That they were arrived at independently under the name "unitary categories" [29, Sect. II.5] underlines their naturality.

In the literature on braided tensor categories additional pieces of structure have been considered, mostly motivated by the study of topological invariants of 3-manifolds.

DEFINITION 2.3. A twist [29] or balancing [14] for a braided tensor category \mathcal{C} is a family $\{\kappa(\rho) \in \text{Hom}(\rho, \rho), \rho \in \mathcal{C}\}$ of invertible arrows satisfying naturality

$$T \circ \kappa(\rho) = \kappa(\sigma) \circ T \quad \forall T \in \text{Hom}(\rho, \sigma) \quad (2.9)$$

and the conditions

$$\kappa(\rho_1 \rho_2) = \kappa(\rho_1) \times \kappa(\rho_1) \circ \varepsilon(\rho_2, \rho_1) \circ \varepsilon(\rho_1, \rho_2) \quad \forall \rho_1, \rho_2 \quad (2.10)$$

$$\kappa(\bar{\rho}) \times \text{id}_\rho \circ R = \text{id}_{\bar{\rho}} \times \kappa(\rho) \circ R \quad (2.11)$$

for every standard solution $(\rho, \bar{\rho}, R, \bar{R})$ of the conjugate equations. In a tensor $*$ -category $\kappa(\rho)$ is required to be unitary.

Remarks. (1) The condition (2.9) is equivalent to saying the κ is a natural transformation of the identity functor to itself. (The set of these was called the center of \mathcal{C} in [10].)

(2) In [14] the definition of a twist does not include (2.11). There a category with conjugates and a twist satisfying (2.11) is called *tortile*.

(3) If ρ is irreducible then we define $\omega(\rho) \in \mathbb{C}$ via $\kappa(\rho) = \omega(\rho) \text{id}_\rho$.

A remarkable feature of the BTC*'s is that they automatically possess a canonically defined twist. It is defined and studied in [19, Theorem 4.2], where, however, the property (2.11) was not proved.

PROPOSITION 2.4. *BTC* are ribbon categories, i.e., have a twist.*

Proof. In [19, Sect. 4] for every BTC* \mathcal{C} a family $\{\kappa(\rho) \in \text{Hom}(\rho, \rho), \rho \in \mathcal{C}\}$ satisfying (2.9), (2.10) was defined, the κ 's being unitary whenever the braiding ε is unitary. (Recall that we assume this throughout.) Thus it only remains to prove (2.11) and in view of the naturality of the twist it is sufficient to consider only irreducible ρ , where (2.11) reduces to $\omega(\rho) = \omega(\bar{\rho})$. This is done in Fig. 1. In the first and last equalities we have used that for ρ irreducible and $\text{Hom}(\rho, \rho) \ni T = C \text{id}_\rho$ we have

$$R^* \circ \text{id}_{\bar{\rho}} \times T \circ R = \bar{R}^* \circ T \times \text{id}_\rho \circ \bar{R} = C d(\rho). \quad (2.12)$$

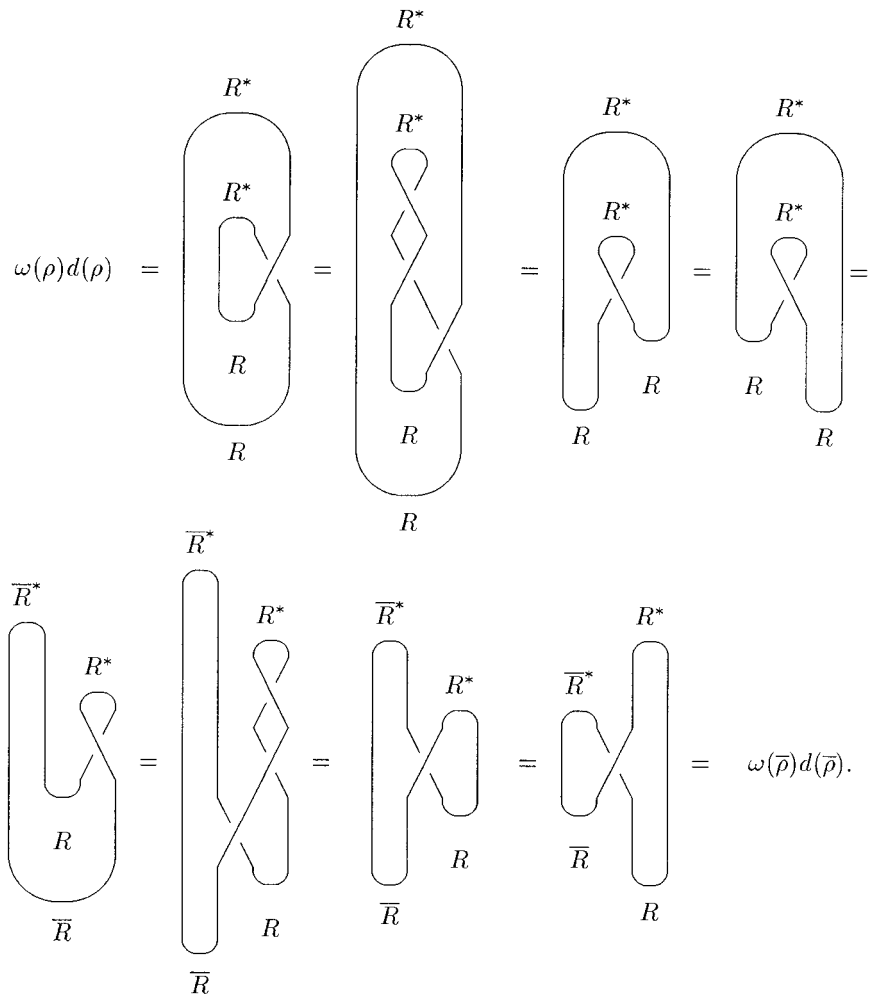

FIG. 1. Proof of $\omega(\rho) = \omega(\bar{\rho})$.

(Here we use $d(\rho) = R^* \circ R = \bar{R}^* \circ \bar{R} = d(\bar{\rho})$, cf. [19].) That the two ways of closing the loop in (2.12) yield the same result is used in the fifth equality of the above calculation. The other steps use nothing more than the interchange law. ■

Remark. This argument has been adapted from algebraic quantum field theory, cf. [17, Lemma II.5.14]. L. Tuset independently arrived at essentially the same proof. The proposition appears already in J. Fröhlich and T. Kerler, “Quantum groups, quantum categories and quantum field theory,” though without proof. In a slightly different setting it is proven in [2].

2.2. The Galois Group of a Braided Tensor Category

DEFINITION 2.5. The monodromy of two objects of a braided tensor category \mathcal{C} is

$$\varepsilon_M(\rho, \sigma) \equiv \varepsilon(\sigma, \rho) \circ \varepsilon(\rho, \sigma) \in \text{Hom}(\rho\sigma, \rho\sigma). \quad (2.13)$$

An object $\sigma \in \mathcal{C}$ is degenerate iff

$$\varepsilon_M(\rho, \eta) = \text{id}_{\rho\eta} \quad \forall \eta \in \mathcal{C}. \quad (2.14)$$

A braided tensor category is degenerate if there is an irreducible degenerate object which is not isomorphic to the unit object ι .

Remark. Clearly, a braided tensor category is symmetric iff all objects are degenerate.

DEFINITION 2.6. Let \mathcal{C} be a BTC*. Then $\mathcal{D}(\mathcal{C})$ is the full subcategory whose objects are the degenerate objects of \mathcal{C} .

PROPOSITION 2.7. $\mathcal{D}(\mathcal{C})$ is a symmetric tensor category with $*$ -operation, conjugates, direct sums, subobjects, and finite dimensional spaces of morphisms.

Proof. For $\rho, \sigma, \eta \in \mathcal{C}$ we have

$$\begin{aligned} \varepsilon_M(\rho\sigma, \eta) &= \varepsilon(\eta, \rho\sigma) \circ \varepsilon(\rho\sigma, \eta) \\ &= \text{id}_{\rho} \times \varepsilon(\eta, \sigma) \circ \varepsilon(\eta, \rho) \times \text{id}_{\sigma} \circ \varepsilon(\rho, \eta) \times \text{id}_{\sigma} \circ \text{id}_{\rho} \times \varepsilon(\sigma, \eta). \end{aligned} \quad (2.15)$$

It is easily seen that this reduces to $\text{id}_{\rho\sigma\eta}$ if ρ and σ have trivial monodromy with η . Thus the set of degenerate objects is closed under multiplication. Now let $\rho \cong \bigoplus_{i \in I} \rho_i$, i.e., there are morphisms $V_i \in \text{Hom}(\rho_i, \rho)$ such that $V_i^* \circ V_j = \delta_{i,j} \text{id}_{\rho_i}$ and $\sum_i V_i \circ V_i^* = \text{id}_{\rho}$. Then by naturality of the braiding we have

$$\varepsilon_M(\rho, \eta) = \sum_i V_i \times \text{id}_{\eta} \circ \varepsilon_M(\sigma_i, \eta) \circ V_i^* \times \text{id}_{\eta}, \quad (2.16)$$

which implies that ρ is degenerate iff all $\rho_i \prec \rho$ are degenerate. Thus the set of degenerate objects is closed under direct sums and subobjects. In order to show that the conjugate of a degenerate object is degenerate, it is sufficient to consider irreducible objects. The following equality is proved by the same argument as already employed in the proof of Proposition 2.4:

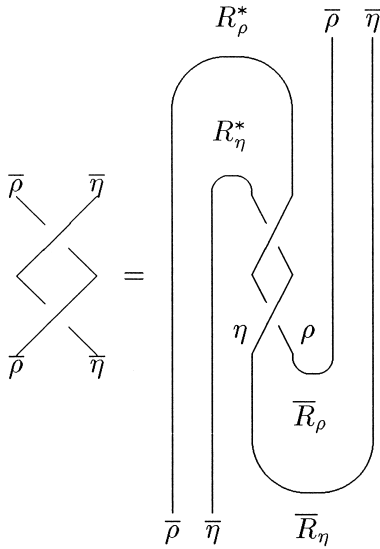

Using this we see that $\varepsilon_M(\rho, \sigma) = \text{id}_{\rho\sigma}$ for all σ implies $\varepsilon_M(\bar{\rho}, \sigma) = \text{id}_{\bar{\rho}\sigma} \forall \sigma$. $\mathcal{D}(\mathcal{C})$ is a STC*, since the braiding of \mathcal{C} is symmetric in restriction to the degenerate objects. ■

Remark. From the above it is clear that $\mathcal{D}(\mathcal{C})$ is the correct object to be denoted as the *center* of \mathcal{C} . This is the analogue for braided tensor categories of the usual center of a monoid (= tensor 0-category), but it must not be confused with yet another definition of a “center,” namely the quantum double $\mathcal{Z}(\mathcal{C})$ (which is a braided tensor category) of a tensor category \mathcal{C} (not necessarily braided).

By the above result and Proposition 2.1, $\mathcal{D}(\mathcal{C})$ satisfies the assumptions of the duality theorem of [6]. We briefly summarize the principal results of [6]. Since every object of a symmetric tensor category \mathcal{S} satisfies $\varepsilon(\rho, \rho)^2 = \text{id}_{\rho^2}$, the twist in a STC* takes only the values ± 1 . (In physics, objects with twist $+1$ and -1 are called bosons and fermions, respectively.) For irreducible ρ_1, ρ_2 , (2.10) reduces to $\kappa(\rho_1\rho_2) = \omega(\rho_1)\omega(\rho_2)\text{id}_{\rho_1\rho_2}$, thus all subobjects of $\rho_1\rho_2$ have the same twist. Therefore the objects with twist $+1$ generate a full subcategory \mathcal{S}_+ which is again a BTC*. We assume for a moment that \mathcal{S} is even, thus $\mathcal{S} = \mathcal{S}_+$. By [6, Theorem 6.1] there is a compact group G unique up to isomorphism such that $\mathcal{S} \cong U(G)$ where $U(G)$ is a category of finite dimensional unitary representations of G containing representers for all isomorphism (unitary equivalence) classes of irreducible representations of G . (Conceptually, the proof of this may be considered to be composed of two steps. First one shows that for a

category with the above properties there is a symmetric C^* -tensor functor F , the embedding functor, into the category \mathcal{H} of Hilbert spaces. F is unique up to a natural transformation. In the second step the Tannaka–Krein reconstruction theorem is applied to the category $F(\mathcal{S})$ and shows that $F(\mathcal{S})$ is isomorphic to a category of representations of a uniquely defined compact group G . But observe that the proof in [6] is independent of the Tannaka–Krein theory in that the group G is constructed simultaneously with the embedding.)

Since all objects in a category $U(G)$ have twist $+1$ the above result cannot hold if \mathcal{S} contains fermionic objects. Yet in this case the braiding in \mathcal{S} can be modified (“bosonized”) such as to obtain an even BTC* \mathcal{S}' and a compact supergroup (G, k) . Here G is the compact group associated to \mathcal{S}' and k is an element of order two in the center of G such that the twist of an irreducible object in \mathcal{S} is the value of k in the associated representation of G . The group G_+ corresponding to \mathcal{S}_+ is just the quotient $G_+ = G/\{e, k\}$.

DEFINITION 2.8. Let \mathcal{C} be a BTC*. Then the absolute Galois group $\text{Gal}(\mathcal{C})$ is the compact group associated by Doplicher and Roberts to the center $\mathcal{D}(\mathcal{C})$ of \mathcal{C} .

Remark. Strictly speaking, $\text{Gal}(\mathcal{C})$ is not a group but an isomorphism class of groups. As soon as a representation functor $F: \mathcal{D}(\mathcal{C}) \rightarrow \mathcal{H}$ has been chosen we have a concrete group $\text{Gal}_F(\mathcal{C})$, the group of natural transformations from F to itself as first considered in [28].

The following discussion serves only to motivate the terminology “modular closure” of Section 4 and may be ignored.

Given two irreducible objects ρ, σ the number $Y_{\rho, \sigma}$ defined by

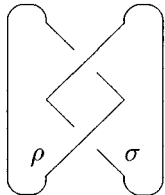
$$Y_{\rho, \sigma} \text{id}_\iota = R_\rho^* \times \overline{R}_\sigma^* \circ \text{id}_{\overline{\rho}} \times \varepsilon_M(\rho, \sigma) \times \text{id}_{\overline{\sigma}} \circ R_\rho \times \overline{R}_\sigma =$$

depends only on the isomorphism classes of ρ, σ .

DEFINITION 2.9. A category is rational if the number of isomorphism classes of irreducible objects is finite.

In a rational category Y gives rise to a (finite) matrix indexed by the isomorphism classes of irreducible objects.

DEFINITION 2.10. A rational BTC^* is modular if the matrix Y is invertible.

Remark. Recall that the existence of a twist which is usually required from a modular category [29] is automatic in BTC^* 's.

PROPOSITION 2.11. *A rational BTC^* is modular iff it is non-degenerate. In the non-degenerate case Y is proportional to a unitary matrix S which together with a certain matrix $T \propto \text{diag}(\omega_i)$ gives rises to a unitary representation of $SL(2, \mathbb{Z})$.*

Proof. The statement is the categorical version of a result from [23] and can be proved by straightforward adaption of the arguments of [23, Sect. 5] to the framework of BTC^* 's. (The factor $d_i d_j$ in [23, (5.11)] is accounted for by the different normalizations of the R 's in [23] and the present paper.) We refrain from giving details since that would use too much space and will not be used in this paper. The claimed fact will be contained as a special case in a more general result, proved in [22]. ■

3. CROSSED PRODUCT OF BRAIDED TENSOR *-CATEGORIES BY SYMMETRIC SUBCATEGORIES

3.1. Definition of the Crossed Product

We assume that \mathcal{C} has direct sums and subobjects, which can be interpreted by saying that reducible objects are always completely reducible, or \mathcal{C} is semisimple. This does not constitute a loss of generality since it can always be achieved by the canonical construction given in [19, Appendix]. We assume $\text{Hom}(\iota, \iota) = \mathbb{C} \text{id}_\iota$, i.e., the unit object ι is irreducible.

In this work we will frequently deal with subcategories $\mathcal{S} \subset \mathcal{C}$. All such subcategories will be assumed replete full. (A subcategory $\mathcal{S} \subset \mathcal{C}$ is full iff $\text{Hom}_{\mathcal{S}}(\rho, \sigma) = \text{Hom}_{\mathcal{C}}(\rho, \sigma) \forall \rho, \sigma \in \mathcal{S}$, thus it is determined by $\text{Obj } \mathcal{S}$. A subcategory is replete iff $\rho \in \mathcal{S}$ implies $\sigma \in \mathcal{S}$ for all $\sigma \in \mathcal{C}$ isomorphic to ρ .) The replete full subcategories of \mathcal{C} form a lattice under inclusion, where $\mathcal{S}_1 \subset \mathcal{S}_2$ means $\text{Obj } \mathcal{S}_1 \subset \text{Obj } \mathcal{S}_2$.

Let now $\mathcal{S} \subset \mathcal{C}$ be a (replete full) symmetric subcategory closed under conjugates, direct sums, and subobjects, the standard example being $\mathcal{D}(\mathcal{C})$ by Proposition 2.7. We do not assume $\mathcal{S} \subset \mathcal{D}(\mathcal{C})$ but we require that \mathcal{S} is even and refer to Subsection 5.3 for the supergroup case. By the duality theorem of Doplicher, and Roberts we have a unique compact group G and an invertible functor $F: \mathcal{S} \rightarrow U(G)$. Here $U(G)$ is a category of finite dimensional continuous unitary representations of G , which is closed under subrepresentations and direct sums and which contains members of each

isomorphism class of irreducible representations. (Note that we did not specify the cardinalities of isomorphism classes in $U(G)$, since they depend on the cardinalities in the given category \mathcal{S} !) The identity object of the category $U(G)$, viz. the space $\mathcal{H}_0 \cong \mathbb{C}$ on which the trivial representation of G “acts,” contains a unit vector Ω such that the following identifications hold:

$$\Omega \boxtimes \psi = \psi \boxtimes \Omega = \psi \quad \forall \mathcal{H} \in \text{Obj } U(G), \quad \psi \in \mathcal{H}. \quad (3.1)$$

In order to avoid confusion with a later use of \otimes , the tensor product of objects in $F(\mathcal{S}) = U(G)$, which are Hilbert spaces, will be denoted by \boxtimes (as already done above) and the product of objects ρ, σ in \mathcal{C} by simple juxtaposition $\rho\sigma$. The composition and tensor product of arrows will be denoted by \circ and \times , respectively, in both categories. Let \hat{G} be the set of all isomorphism classes of irreducible objects in \mathcal{S} or, equivalently by the duality theorem, of irreducible representations of G . Let $\{\gamma_k, k \in \hat{G}\}$ be a section of objects in \mathcal{S} such that $\gamma_0 = \iota$ and let $\mathcal{H}_k = F(\gamma_k)$ be the images under the functor F . For every triple $k, l, m \in \hat{G}$ we choose an orthonormal basis

$$\{V_{k,l}^{m,\alpha}, \alpha = 1, \dots, N_{k,l}^m\} \quad (3.2)$$

in the space $\text{Hom}(\gamma_m, \gamma_k \gamma_l)$. (The latter space of arrows is in fact a Hilbert space, but it should not be confused with the spaces $\mathcal{H}_k, k \in \hat{G}$.)

The set \hat{G} has an involution $k \mapsto \bar{k}$ which associates to every isomorphism class of representations of G the conjugate class. By the isomorphism between $\mathcal{S} \cong U(G)$ this implies for our chosen section that $\gamma_{\bar{k}}$ is conjugate to γ_k . Thus there are intertwiners $R_k \in \text{Hom}(\iota, \gamma_{\bar{k}} \gamma_k)$, $\bar{R}_k \in \text{Hom}(\iota, \gamma_k \gamma_{\bar{k}})$ such that

$$\bar{R}_k^* \times \text{id}_{\gamma_k} \circ \text{id}_{\gamma_k} \times R_k = \text{id}_{\gamma_k}, \quad R_k^* \times \text{id}_{\gamma_{\bar{k}}} \circ \text{id}_{\gamma_{\bar{k}}} \times \bar{R}_k = \text{id}_{\gamma_{\bar{k}}}. \quad (3.3)$$

Since this is symmetric under $k \leftrightarrow \bar{k}, R \leftrightarrow \bar{R}$ one can choose $R_{\bar{k}} = \bar{R}_k, \bar{R}_{\bar{k}} = R_k$ for conjugate pairs of non-selfconjugate objects. For selfconjugate objects it is known that one can achieve either $\bar{R}_k = R_k$ or $\bar{R}_k = -R_k$ depending on whether γ_k is real or pseudo-real. The above choices will be assumed in the sequel.

Now we define a new category $\mathcal{C} \rtimes_0 \mathcal{S}$ in terms of the data $\mathcal{C}, \mathcal{S}, F, \hat{G}$.

DEFINITION 3.1. The category $\mathcal{C} \rtimes_0 \mathcal{S}$ has the same objects as \mathcal{C} with the same tensor product. The arrows in $\mathcal{C} \rtimes_0 \mathcal{S}$ are defined by

$$\text{Hom}_{\mathcal{C} \rtimes_0 \mathcal{S}}(\rho, \sigma) = \bigoplus_{k \in \hat{G}} \text{Hom}_{\mathcal{C}}(\gamma_k \rho, \sigma) \otimes \mathcal{H}_k \quad (3.4)$$

with the obvious complex vector space structure. In order to economize on brackets we declare the precedence of products to be $\otimes > \times > \circ > \otimes$, where \otimes, \boxtimes are different symbols for the tensor product in (3.4).

Let $k, l \in \hat{G}, T \in \text{Hom}(\gamma_l \rho, \sigma), S \in \text{Hom}(\gamma_k \sigma, \delta)$, and $\psi_k \in \mathcal{H}_k, \psi_l \in \mathcal{H}_l$. Then the composition of arrows in $\mathcal{C} \rtimes_0 \mathcal{S}$ is defined by

$$\begin{aligned} \text{Hom}_{\mathcal{C} \rtimes_0 \mathcal{S}}(\rho, \delta) &\ni S \otimes \psi_k \circ T \otimes \psi_l \\ &= \bigoplus_{m \in \hat{G}} \sum_{\alpha=1}^{N_{k,l}^m} S \circ \text{id}_{\gamma_k} \times T \circ V_{k,l}^{m,\alpha} \times \text{id}_\rho \otimes F(V_{k,l}^{m,\alpha})^* (\psi_k \boxtimes \psi_l) \end{aligned} \quad (3.5)$$

and linear extension. Here F is the embedding functor, thus $F(V_{k,l}^{m,\alpha})^*$ is a partial isometry from $\mathcal{H}_k \boxtimes \mathcal{H}_l$ onto \mathcal{H}_m .

Let $k, l \in \hat{G}, S \in \text{Hom}(\gamma_k \rho_1, \sigma_1), T \in \text{Hom}(\gamma_l \rho_2, \sigma_2)$, and $\psi_k \in \mathcal{H}_k, \psi_l \in \mathcal{H}_l$. Then the tensor product of arrows in $\mathcal{C} \rtimes_0 \mathcal{S}$ is defined by

$$\begin{aligned} \text{Hom}_{\mathcal{C} \rtimes_0 \mathcal{S}}(\rho_1 \rho_2, \sigma_1 \sigma_2) &\ni S \otimes \psi_k \times T \otimes \psi_l \\ &= \bigoplus_{m \in \hat{G}} \sum_{\alpha=1}^{N_{k,l}^m} S \times T \circ \text{id}_{\gamma_k} \times \varepsilon(\gamma_l, \rho_1) \times \text{id}_{\rho_2} \circ V_{k,l}^{m,\alpha} \times \text{id}_{\rho_1 \rho_2} \\ &\quad \otimes F(V_{k,l}^{m,\alpha})^* (\psi_k \boxtimes \psi_l). \end{aligned} \quad (3.6)$$

Finally, the $*$ -operation of $\mathcal{C} \rtimes_0 \mathcal{S}$ on the arrows $S \otimes \psi_k \in \text{Hom}_{\mathcal{C} \rtimes_0 \mathcal{S}}(\rho, \sigma)$ with $S \in \text{Hom}(\gamma_k \rho, \sigma), \psi \in \mathcal{H}_k$ is defined by

$$(S \otimes \psi_k)^* = R_k^* \times \text{id}_\rho \circ \text{id}_{\gamma_k} \times S^* \otimes \langle \psi_k \boxtimes \cdot, F(\bar{R}_k) \Omega \rangle. \quad (3.7)$$

Remarks. (1) Tangle diagrams corresponding to the first tensor factor (which lives in the category \mathcal{C}) in the definitions of \circ, \times , and $*$ are given in Figs. 2 and 3.

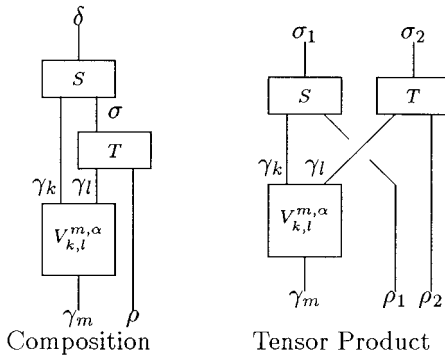

FIG. 2. Composition (left) and tensor product (right) of arrows in $\mathcal{C} \rtimes_0 \mathcal{S}$.

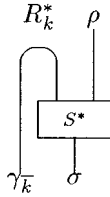

FIG. 3. The $*$ -operation on arrows.

(2) A different choice for the orthonormal bases $\{V_{k,l}^{m,\alpha}, \alpha = 1, \dots, N_{k,l}^m\}$ in $\text{Hom}(\gamma_m, \gamma_k \gamma_l)$ does not affect the definition of \circ, \times , since the unitary matrices effecting the base change drop out.

(3) The left tensor factor of (3.7) is in $\text{Hom}(\gamma_{\bar{k}} \sigma, \rho)$, and $F(\bar{R}_{\gamma_k}) \Omega$ is in $\mathcal{H}_k \boxtimes \mathcal{H}_{\bar{k}}$ such that contraction with ψ_k yields a vector in $\mathcal{H}_{\bar{k}}$. Thus the entire expression is in $\text{Hom}_{\mathcal{C} \rtimes_0 \mathcal{S}}(\sigma, \rho)$ as it must be.

(4) For every pair ρ, σ there is an embedding of $\text{Hom}_{\mathcal{C}}(\rho, \sigma)$ into $\text{Hom}_{\mathcal{C} \rtimes_0 \mathcal{S}}(\rho, \sigma)$ via $S \mapsto S \otimes \Omega$. Looking at the definitions of \circ, \times in $\mathcal{C} \rtimes_0 \mathcal{S}$ it is obvious that this gives rise to a faithful functor from \mathcal{C} to $\mathcal{C} \rtimes_0 \mathcal{S}$, thus \mathcal{C} can and will be considered as a subcategory of $\mathcal{C} \rtimes_0 \mathcal{S}$. Arrows in $\mathcal{C} \rtimes_0 \mathcal{S}$ will be denoted $\tilde{S}, \tilde{T}, \dots$, but often we do not distinguish between $S \in \text{Hom}_{\mathcal{C}}(\rho, \sigma)$ and $S \otimes \Omega \in \text{Hom}_{\mathcal{C} \rtimes_0 \mathcal{S}}(\rho, \sigma)$.

(5) By Frobenius reciprocity we have $\dim \text{Hom}(\gamma_k \rho, \sigma) = \dim \text{Hom}(\gamma_k, \sigma \bar{\rho}) < \infty$ and only finitely many $k \in \hat{G}$ contribute, thus $\text{Hom}_{\mathcal{C} \rtimes_0 \mathcal{S}}(\rho, \sigma)$ is finite dimensional. As a consequence of $\text{Hom}(\gamma_k, \iota) = \{0\}$ for $k \neq e$ we obtain

$$\text{Hom}_{\mathcal{C} \rtimes_0 \mathcal{S}}(\iota, \iota) = \text{Hom}(\iota, \iota) = \mathbb{C} \text{id}_{\iota}. \tag{3.8}$$

(6) A special case of (3.4) is

$$\text{Hom}_{\mathcal{C} \rtimes_0 \mathcal{S}}(\iota, \gamma_k) = \text{Hom}(\gamma_k, \gamma_k) \otimes \mathcal{H}_k \tag{3.9}$$

for $\gamma_k \in \mathcal{S}$. Since the dimension $d_k \in \mathbb{N}$ of γ_k equals the dimension of $\mathcal{H}_k = F(\gamma_k)$, this implies $\gamma_k \cong d_k \iota$ in $\mathcal{C} \rtimes_0 \mathcal{S}$. Thus γ_k “disappears without a trace” in $\mathcal{C} \rtimes_0 \mathcal{S}$ as far as the irreducible objects are concerned. Furthermore, the spaces \mathcal{H}_k and $\text{Hom}_{\mathcal{C} \rtimes_0 \mathcal{S}}(\iota, \gamma_k)$ can be identified via $\psi \mapsto \text{id}_{\gamma_k} \otimes \psi$. This allows us to consider $\psi_k \in \mathcal{H}_k$ also as a morphism in $\text{Hom}_{\mathcal{C} \rtimes_0 \mathcal{S}}(\iota, \gamma_k)$, which leads to notational simplification. With $S \in \text{Hom}(\gamma_k \rho, \sigma), \psi_k \in \mathcal{H}_k$ it is an easy consequence of (3.5, 3.6) that $\text{Hom}_{\mathcal{C} \rtimes_0 \mathcal{S}}(\rho, \sigma) \ni S \otimes \psi_k = S \otimes \Omega \circ \text{id}_{\gamma_k} \otimes \psi_k \times \text{id}_{\rho} \otimes \Omega$. With the above identifications this can also be written as $S \circ \psi_k \times \text{id}_{\rho}$. In a sense, the new morphisms $\psi_k \in \text{Hom}_{\mathcal{C} \rtimes_0 \mathcal{S}}(\iota, \gamma_k)$ are the crucial point of Definition 3.1 and (3.4) simply

reflects the fact that arrows can be composed. It must of course still be proved that Definition 3.1 yields a BTC*.

(7) If $\mathcal{S} \not\subset \mathcal{D}$ then $\varepsilon(\gamma, \rho) \circ \varepsilon(\rho, \gamma) \neq \text{id}_{\rho\gamma}$ for some $\gamma \in \mathcal{S}$, $\rho \in \mathcal{C}$. Thus there is another possible definition of \times in $\mathcal{C} \rtimes_0 \mathcal{S}$, replacing $\varepsilon(\gamma_l, \rho_1)$ by $\varepsilon(\rho_1, \gamma_l)^{-1}$ in (3.6). For $\mathcal{S} \subset \mathcal{D}$ these definitions coincide.

(8) Finally, we remark that there are similarities between our definition of $\mathcal{C} \rtimes_0 \mathcal{S}$ and a construction [25] of a field algebra in algebraic quantum field theory which preceded [7] but where the main result of [6] was assumed.

3.2. $\mathcal{C} \rtimes_0 \mathcal{S}$ Is a Tensor Category

LEMMA 3.2. *The operations \circ , \times are bilinear and associative.*

Proof. Bilinearity is obvious. In order to prove associativity of \circ consider S, T as in the definition (3.5) and $U \in \text{Hom}(\gamma_n \eta, \rho)$. Then,

$$\begin{aligned} & (S \otimes \psi_k \circ T \otimes \psi_l) \circ U \otimes \psi_n \\ &= \bigoplus_{r \in \hat{G}} \sum_{m \in \hat{G}} \sum_{\alpha=1}^{N_{k,l}^m} \sum_{\beta=1}^{N_{m,n}^r} S \circ \text{id}_{\gamma_k} \times T \circ \text{id}_{\gamma_k \gamma_l} \times U \circ V_{k,l}^{m,\alpha} \times \text{id}_{\gamma_n \eta} \circ V_{m,n}^{r,\beta} \times \text{id}_{\eta} \\ & \quad \otimes (F(V_{m,n}^{r,\beta})^* \circ F(V_{k,l}^{m,\alpha})^* \times \text{id}_{\mathcal{H}_n})(\psi_k \boxtimes \psi_l \boxtimes \psi_n). \end{aligned} \quad (3.10)$$

On the other hand

$$\begin{aligned} & S \otimes \psi_k \circ (T \otimes \psi_l \circ U \otimes \psi_n) \\ &= \bigoplus_{r \in \hat{G}} \sum_{m \in \hat{G}} \sum_{\alpha=1}^{N_{l,n}^m} \sum_{\beta=1}^{N_{k,m}^r} S \circ \text{id}_{\gamma_k} \times T \circ \text{id}_{\gamma_k \gamma_l} \times U \circ \text{id}_{\gamma_k} \times V_{k,l}^{m,\alpha} \times \text{id}_{\eta} \circ V_{k,m}^{r,\beta} \times \text{id}_{\eta} \\ & \quad \otimes (F(V_{k,m}^{r,\beta})^* \circ \text{id}_{\mathcal{H}_k} \times F(V_{l,n}^{m,\alpha})^*)(\psi_k \boxtimes \psi_l \boxtimes \psi_n). \end{aligned} \quad (3.11)$$

Since F is a functor of $*$ -categories we have

$$F(V_{m,n}^{r,\beta})^* \circ F(V_{k,l}^{m,\alpha})^* \times \text{id}_{\mathcal{H}_n} = F(V_{k,l}^{m,\alpha} \times \text{id}_{\gamma_n} \circ V_{m,n}^{r,\beta})^*, \quad (3.12)$$

$$F(V_{k,m}^{r,\beta})^* \circ \text{id}_{\mathcal{H}_k} \times F(V_{l,n}^{m,\alpha})^* = F(\text{id}_{\gamma_k} \times V_{l,n}^{m,\alpha} \circ V_{k,m}^{r,\beta})^*. \quad (3.13)$$

Since both

$$\{ V_{k,l}^{m,\alpha} \times \text{id}_{\gamma_n} \circ V_{m,n}^{r,\beta}, \quad m \in \hat{G}, \alpha = 1, \dots, N_{k,l}^m, \beta = 1, \dots, N_{m,n}^r \} \quad (3.14)$$

and

$$\{ \text{id}_{\gamma_k} \times V_{l,n}^{m,\alpha} \circ V_{k,m}^{r,\beta}, \quad m \in \hat{G}, \alpha = 1, \dots, N_{l,n}^m, \beta = 1, \dots, N_{k,m}^r \} \quad (3.15)$$

are orthogonal bases of $\text{Hom}(\gamma_r, \gamma_k \gamma_l \gamma_n)$, the two expressions coincide.

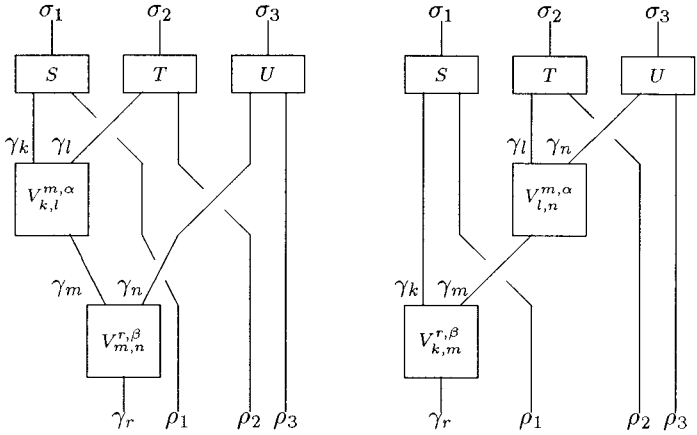

$$(S \otimes \psi_k \times T \otimes \psi_l) \times U \otimes \psi_n \quad S \otimes \psi_k \times (T \otimes \psi_l \times U \otimes \psi_n)$$

FIG. 4. Associativity of \times .

The proof of associativity of \times is similar. Let S, T be as in (3.6) and let $U \in \text{Hom}(\gamma_n \rho_3, \sigma_3)$. Since writing down (and reading!) the formulae would be rather tedious we express the parts of the summands which live in \mathcal{C} graphically, cf. Fig. 4. Thus

$$\begin{aligned} & (S \otimes \psi_k \times T \otimes \psi_l) \times U \otimes \psi_n \\ &= \bigoplus_{r \in \hat{G}} \sum_{m \in \hat{G}} \sum_{\alpha=1}^{N_{k,l}^m} \sum_{\beta=1}^{N_{m,n}^r} (\text{Fig. 4, l.h.s.}) \otimes F(V_{k,l}^{m,\alpha} \times \text{id}_{\gamma_n} \circ V_{m,n}^{r,\beta})^* \\ & (\psi_k \boxtimes \psi_l \boxtimes \psi_n). \end{aligned} \quad (3.16)$$

On the other hand

$$\begin{aligned} & S \otimes \psi_k \times (T \otimes \psi_l \times U \otimes \psi_n) \\ &= \bigoplus_{r \in \hat{G}} \sum_{m \in \hat{G}} \sum_{\alpha=1}^{N_{l,n}^m} \sum_{\beta=1}^{N_{k,m}^r} (\text{Fig. 4, r.h.s.}) \otimes F(\text{id}_{\gamma_k} \times V_{l,n}^{m,\alpha} \circ V_{k,m}^{r,\beta})^* \\ & (\psi_k \boxtimes \psi_l \boxtimes \psi_n). \end{aligned} \quad (3.17)$$

By naturality the arrow $V_{l,n}^{m,\alpha}$ in the r.h.s. of Fig. 4 can be pulled through the braiding, and the identity of the two expressions follows by the same argument as for \circ . ■

LEMMA 3.3. *The operations \circ, \times satisfy the interchange law*

$$(\tilde{S}_1 \circ \tilde{T}_1) \times (\tilde{S}_2 \circ \tilde{T}_2) = \tilde{S}_1 \times \tilde{S}_2 \circ \tilde{T}_1 \times \tilde{T}_2, \tag{3.18}$$

whenever the left hand side is defined.

Proof. We compute

$$\begin{aligned} & (S_1 \otimes \psi_k \circ T_1 \otimes \psi_l) \times (S_2 \otimes \psi_m \circ T_2 \otimes \psi_n) \\ &= \bigoplus_{r \in \hat{G}} \sum_{p, q \in \hat{G}} \sum_{\alpha=1}^{N_{k,l}^p} \sum_{\beta=1}^{N_{m,n}^q} \sum_{\delta=1}^{N_{p,q}^r} (\text{Fig. 5, l.h.s.}) \otimes F(V_{k,l}^{p,\alpha} \times V_{m,n}^{q,\beta} \circ V_{p,q}^{r,\delta})^* \\ & (\psi_k \boxtimes \psi_l \boxtimes \psi_m \boxtimes \psi_n) \end{aligned} \tag{3.19}$$

and

$$\begin{aligned} & S_1 \otimes \psi_k \times S_2 \otimes \psi_m \circ T_1 \otimes \psi_l \times T_2 \otimes \psi_n \\ &= \bigoplus_{r \in \hat{G}} \sum_{p, q \in \hat{G}} \sum_{\alpha=1}^{N_{k,m}^p} \sum_{\beta=1}^{N_{l,n}^q} \sum_{\delta=1}^{N_{p,q}^r} (\text{Fig. 6, l.h.s.}) \otimes F(V_{k,m}^{p,\alpha} \times V_{l,n}^{q,\beta} \circ V_{p,q}^{r,\delta})^* \\ & (\psi_k \boxtimes \psi_l \boxtimes \psi_m \boxtimes \psi_n) \end{aligned} \tag{3.20}$$

(Since \mathcal{S} is a symmetric category we have used the symmetric braiding symbol for $\varepsilon(\gamma_m, \gamma_l)$ in Fig. 6. We do not do this for braidings of γ 's with objects not in \mathcal{S} since we do not assume \mathcal{S} to be degenerate.) By standard

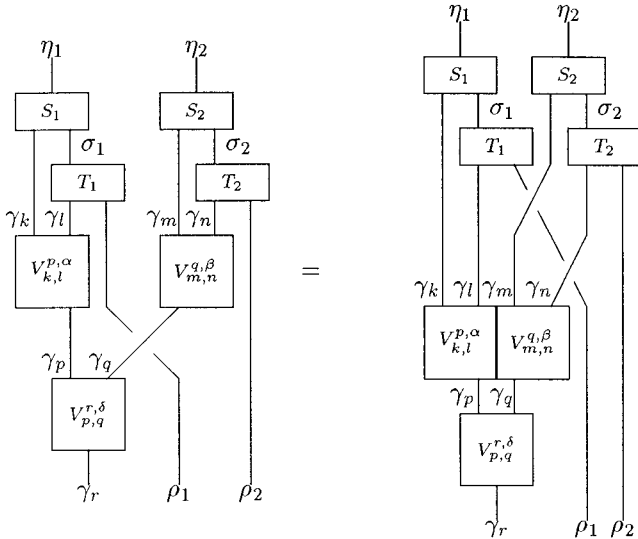

FIG. 5. $(S_1 \otimes \psi_k \circ T_1 \otimes \psi_l) \times (S_2 \otimes \psi_m \circ T_2 \otimes \psi_n)$.

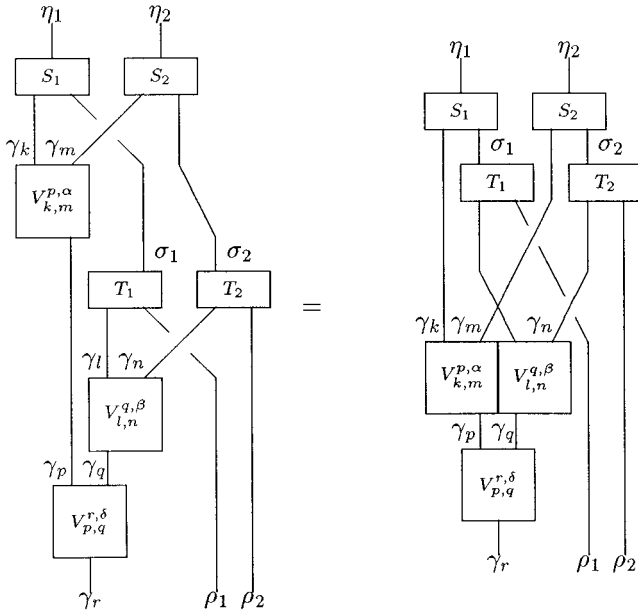

FIG. 6. $S_1 \otimes \psi_k \times S_2 \otimes \psi_m \circ T_1 \otimes \psi_l \times T_2 \otimes \psi_n$.

manipulations the left hand sides of Figs. 5, 6 can be seen to equal the respective right hand sides. Next we transform (3.20) using

$$\begin{aligned}
 & F(V_{k,m}^{p,\alpha} \times V_{l,n}^{q,\beta} \circ V_{p,q}^{r,\delta})^* (\psi_k \boxtimes \psi_m \boxtimes \psi_l \boxtimes \psi_n) \\
 &= F(\text{id}_{\gamma_k} \times \varepsilon(\gamma_m, \gamma_l) \times \text{id}_{\gamma_n} \circ V_{k,m}^{p,\alpha} \times V_{l,n}^{q,\beta} \circ V_{p,q}^{r,\delta})^* \\
 & \quad (\psi_k \boxtimes \psi_l \boxtimes \psi_m \boxtimes \psi_n), \tag{3.21}
 \end{aligned}$$

and observing that $\{V_{k,l}^{p,\alpha} \times V_{m,n}^{q,\beta} \circ V_{p,q}^{r,\delta}\}$ and $\{\text{id}_{\gamma_k} \times \varepsilon(\gamma_m, \gamma_l) \times \text{id}_{\gamma_n} \circ V_{k,m}^{p,\alpha} \times V_{l,n}^{q,\beta} \circ V_{p,q}^{r,\delta}\}$ are orthonormal bases of $\text{Hom}(\gamma_r, \gamma_k \gamma_l \gamma_m \gamma_n)$ (with $p, q \in \hat{G}$ and α, β, δ in the obvious ranges) we are done. ■

LEMMA 3.4. $\mathcal{C} \rtimes_0 \mathcal{S}$ has conjugates and direct sums.

Proof. Since the objects of $\mathcal{C} \rtimes_0 \mathcal{S}$ are just those of \mathcal{C} the existence of conjugates in $\mathcal{C} \rtimes_0 \mathcal{S}$ follows from

$$R_k \in \text{Hom}(l, \gamma_k \gamma_k) \subset \text{Hom}_{\mathcal{C} \rtimes_0 \mathcal{S}}(l, \gamma_k \gamma_k) \tag{3.22}$$

and the fact that the conjugate equations clearly hold in $\mathcal{C} \rtimes_0 \mathcal{S}$, too. In the same way one shows that $\mathcal{C} \rtimes_0 \mathcal{S}$ has direct sums. ■

3.3. The $*$ -Operation

LEMMA 3.5. *The $*$ -operation is antilinear and involutive.*

Proof. Antilinearity is obvious by definition. As to involutivity consider $\tilde{S} = S \otimes \psi_k$ with $S \in \text{Hom}(\gamma_k \rho, \sigma)$, $\psi \in \mathcal{H}_k$. Twofold application of the $*$ -operation (3.7) yields

$$(S \otimes \psi_k)^{**} = R_k^* \times \text{id}_\sigma \circ \text{id}_{\gamma_k \gamma_{\bar{k}}} \times S \circ \text{id}_{\gamma_k} \times R_k \times \text{id}_\rho \otimes \langle \bar{\psi}_{\bar{k}} \boxtimes \cdot, F(\bar{R}_{\bar{k}}) \Omega \rangle, \tag{3.23}$$

where

$$\bar{\psi}_{\bar{k}} = \langle \psi_k \boxtimes \cdot, F(\bar{R}_k) \Omega \rangle. \tag{3.24}$$

The first tensor factor of (3.23) (which lives in \mathcal{C}) can be transformed as follows:

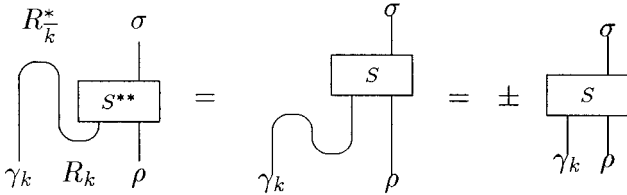

In the first step we have used the interchange law and in the second step the first conjugate Eq. (3.3). The possible appearance of the minus sign is due the fact that R_k^* appears in (3.23) instead of \bar{R}_k^* . In view of our choice of $R_{\bar{k}} = \pm \bar{R}_k$ the minus sign appears iff k is selfconjugate and pseudo-real. Abbreviating the second factor in (3.23) (which lives in $U(G)$) by $\bar{\psi}_{\bar{k}}$ we have

$$\langle a, \bar{\bar{\psi}}_k \rangle = \langle \bar{\psi}_{\bar{k}} \boxtimes a, F(\bar{R}_{\bar{k}}) \Omega \rangle \quad \forall a \in \mathcal{H}_k. \tag{3.26}$$

Inserting

$$\langle \bar{\psi}_{\bar{k}}, b \rangle = \langle F(\bar{R}_k) \Omega, \psi_k \boxtimes b \rangle \quad \forall b \in \mathcal{H}_{\bar{k}} \tag{3.27}$$

we have

$$\begin{aligned} \langle a, \bar{\bar{\psi}}_k \rangle &= \langle F(\bar{R}_k) \Omega \boxtimes a, \psi_k \boxtimes F(\bar{R}_{\bar{k}}) \Omega \rangle \\ &= \langle \Omega \boxtimes a, F(\bar{R}_k^* \times \text{id}_{\gamma_k} \circ \text{id}_{\gamma_k} \times \bar{R}_{\bar{k}}) \psi_k \boxtimes \Omega \rangle. \end{aligned} \tag{3.28}$$

Now $\bar{R}_k^* \times \text{id}_{\gamma_k} \circ \text{id}_{\gamma_k} \times \bar{R}_{\bar{k}} = \pm \text{id}_{\gamma_k}$, thus $F(\dots) = \pm \text{id}_{\mathcal{H}_k}$. With $\Omega \boxtimes a = a$ and $\psi_k \boxtimes \Omega = \psi_k$ we have $\langle a, \bar{\bar{\psi}}_k \rangle = \pm \langle a, \psi_k \rangle$ and therefore $\bar{\bar{\psi}}_k = \pm \psi_k$. Also

here the minus sign appears iff k is selfconjugate and pseudoreal. In any case the two minus signs cancel and we obtain $(S \otimes \psi_k)^{**} = (S \otimes \psi_k)$. ■

LEMMA 3.6. *The $*$ -operation is contravariant, i.e., $(\tilde{S} \circ \tilde{T})^* = \tilde{T}^* \circ \tilde{S}^*$ whenever the left hand side is defined.*

Proof. Let $S \in \text{Hom}(\gamma_k \sigma, \delta)$, $T \in \text{Hom}(\gamma_l \rho, \sigma)$, and $\psi_k \in \mathcal{H}_k$, $\psi_l \in \mathcal{H}_l$ and apply the $*$ -operation (3.7) to $\tilde{S} \circ \tilde{T} = S \otimes \psi_k \circ T \otimes \psi_l$ as defined by (3.6). We obtain

$$\begin{aligned}
 (\tilde{S} \circ \tilde{T})^* &= \bigoplus_{m \in \hat{G}} \sum_{\alpha=1}^{N_{k,l}^m} R_m^* \times \text{id}_\rho \circ \text{id}_{\gamma_m} \times V_{k,l}^{m,\alpha*} \times \text{id}_\rho \circ \text{id}_{\gamma_m \gamma_k} \times T^* \circ \text{id}_{\gamma_m} \times S^* \\
 &\quad \otimes \langle F(V_{k,l}^{m,\alpha})^* (\psi_k \boxtimes \psi_l) \boxtimes \cdot, F(\bar{R}_m) \Omega \rangle.
 \end{aligned}
 \tag{3.29}$$

On the other hand,

$$\begin{aligned}
 \tilde{T}^* \circ \tilde{S}^* &= \bigoplus_{m \in \hat{G}} \sum_{\alpha=1}^{N_{\bar{k},\bar{l}}^m} R_l^* \times \text{id}_\rho \circ \text{id}_{\gamma_l} \times T^* \circ \text{id}_{\gamma_l} \times R_k^* \times \text{id}_\sigma \circ V_{\bar{l},\bar{k}}^{m,\alpha} \times S^* \\
 &\quad \otimes F(V_{\bar{l},\bar{k}}^{m,\alpha})^* (\bar{\psi}_{\bar{l}} \boxtimes \bar{\psi}_{\bar{k}}),
 \end{aligned}
 \tag{3.30}$$

where

$$\bar{\psi}_{\bar{l}} = \langle \psi_l \boxtimes \cdot, F(\bar{R}_l) \Omega \rangle
 \tag{3.31}$$

and similarly for $\bar{\psi}_{\bar{k}}$. The left tensor factors of (3.29) and (3.30) are represented in Fig. 7.

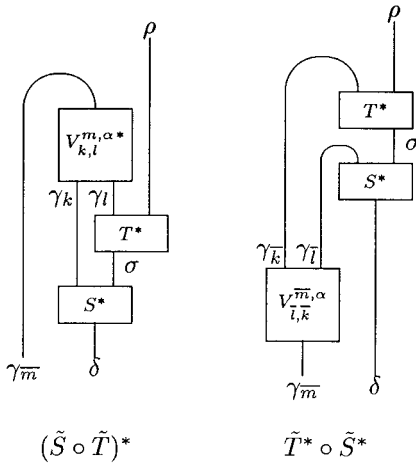

FIG. 7. Compatibility of $*$ and \circ .

As to the right hand factors of (3.29) and (3.30) which live in $\mathcal{H}_{\bar{m}}$ and which we abbreviate ψ_1, ψ_2 , respectively, we have for all $a \in \mathcal{H}_{\bar{m}}$,

$$\begin{aligned} \langle a, \psi_1 \rangle &= \langle F(V_{k,l}^{m,\alpha})^* (\psi_k \boxtimes \psi_l) \boxtimes a, F(\bar{R}_m) \Omega \rangle \\ &= \langle \psi_k \boxtimes \psi_l \boxtimes a, F(V_{k,l}^{m,\alpha} \times \text{id}_{\gamma_{\bar{m}}} \circ \bar{R}_m) \Omega \rangle \end{aligned} \quad (3.33)$$

and

$$\begin{aligned} \langle a, \psi_2 \rangle &= \langle a, F(V_{\bar{l},\bar{k}}^{\bar{m},\alpha})^* (\bar{\psi}_{\bar{l}} \boxtimes \bar{\psi}_{\bar{k}}) \rangle = \langle F(V_{\bar{l},\bar{k}}^{\bar{m},\alpha}) a, \bar{\psi}_{\bar{l}} \boxtimes \bar{\psi}_{\bar{k}} \rangle \\ &= \langle \psi_k \boxtimes \psi_l \boxtimes F(V_{\bar{l},\bar{k}}^{\bar{m},\alpha}) a, [F(\bar{R}_l) \Omega]_{23} [F(\bar{R}_k) \Omega]_{14} \rangle \\ &= \langle \psi_k \boxtimes \psi_l \boxtimes F(V_{\bar{l},\bar{k}}^{\bar{m},\alpha}) a, F(\text{id}_{\gamma_k} \times \bar{R}_l \times \text{id}_{\gamma_{\bar{k}}} \circ \bar{R}_k) \Omega \rangle \\ &= \langle \psi_k \boxtimes \psi_l \boxtimes a, F(\text{id}_{\gamma_k \gamma_l} \times V_{\bar{l},\bar{k}}^{\bar{m},\alpha*} \circ \text{id}_{\gamma_{\bar{k}}} \times \bar{R}_l \times \text{id}_{\gamma_{\bar{k}}} \circ \bar{R}_k) \Omega \rangle. \end{aligned} \quad (3.34)$$

The fourth equality in (3.34) follows from the following computation in $\mathcal{H}_{\bar{k}} \boxtimes \mathcal{H}_{\bar{l}} \boxtimes \mathcal{H}_{\bar{l}} \boxtimes \mathcal{H}_{\bar{k}}$,

$$\begin{aligned} [F(\bar{R}_l) \Omega]_{23} [F(\bar{R}_k) \Omega]_{14} &= \sigma_{12} \circ \sigma_{23} (F(\bar{R}_l) \Omega \boxtimes F(\bar{R}_k) \Omega) \\ &= F(\varepsilon(\gamma_l \gamma_{\bar{l}}, \gamma_k) \times \text{id}_{\gamma_{\bar{k}}} \circ \bar{R}_l \times \bar{R}_k) \Omega \\ &= F(\text{id}_{\gamma_k} \times \bar{R}_l \times \text{id}_{\gamma_{\bar{k}}} \circ \bar{R}_k) \Omega, \end{aligned} \quad (3.35)$$

where in the last step we have used the interchange law.

Now we observe that $\{W_{k,l}^{m,\beta}, \beta = 1, \dots, N_{k,l}^m\}$ with

$$W_{k,l}^{m,\beta} = \bar{R}_m^* \circ \text{id}_{\gamma_m} \times V_{\bar{l},\bar{k}}^{\bar{m},\beta*} \circ \text{id}_{\gamma_m \gamma_{\bar{l}}} \times R_k \times \text{id}_{\gamma_l} \circ \text{id}_{\gamma_m} \times R_l \quad (3.36)$$

is an orthonormal basis in $\text{Hom}(\gamma_m, \gamma_k \gamma_l)$. Since the choice of such a basis is irrelevant we can replace $V_{k,l}^{m,\alpha}$ in (3.29) by $W_{k,l}^{m,\alpha}$. Using the conjugate equations (3.3) one then easily verifies that (3.29) and (3.30) coincide. ■

LEMMA 3.7. *The *-operation is monoidal, i.e., $(S \times T)^* = S^* \times T^*$.*

Proof. Let $S \in \text{Hom}(\gamma_k \rho_1, \sigma_1)$, $T \in \text{Hom}(\gamma_l \rho_2, \sigma_2)$, $\psi_k \in \mathcal{H}_k$, $\psi_l \in \mathcal{H}_l$. Then

$$(\tilde{S} \times \tilde{T})^* = \bigoplus_{m \in \hat{G}} \sum_{\alpha=1}^{N_{k,l}^m} (\text{Fig. 8, l.h.s.}) \otimes \langle F(V_{k,l}^{m,\alpha})^* (\psi_k \boxtimes \psi_l) \boxtimes \cdot, F(\bar{R}_m) \Omega \rangle. \quad (3.37)$$

On the other hand,

$$\tilde{S}^* \times \tilde{T}^* = \bigoplus_{m \in \hat{G}} \sum_{\alpha=1}^{N_{k,l}^m} (\text{Fig. 8, r.h.s.}) \otimes F(V_{k,l}^{m,\alpha})^* (\bar{\psi}_{\bar{k}} \boxtimes \bar{\psi}_{\bar{l}}). \quad (3.38)$$

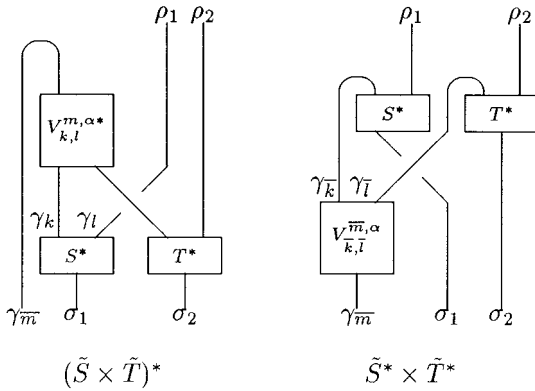
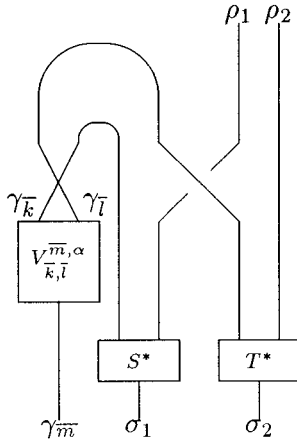

FIG. 8. Compatibility of $*$ and \times .

Using the interchange law several times, the right hand side of Fig. 8 is shown to equal



which differs from the left hand side of Fig. 8 only by a replacement of the basis

$$\{R_m^* \circ \text{id}_{\gamma_{\bar{m}}} \times V_{k,l}^{m,\alpha^*}, \alpha = 1, \dots, N_{k,l}^m\} \tag{3.40}$$

of $\text{Hom}(\gamma_{\bar{m}}\gamma_k\gamma_l, \iota)$ by

$$\{R_l^* \circ \text{id}_{\gamma_l} \times R_k^* \times \text{id}_{\gamma_l} \circ (\varepsilon(\gamma_{\bar{k}}, \gamma_{\bar{l}}) \circ V_{\bar{k},\bar{l}}^{\bar{m},\alpha}) \times \text{id}_{\gamma_k\gamma_l}, \alpha = 1, \dots, N_{k,l}^m\}. \tag{3.41}$$

Concerning the right hand sides the calculation proceeds as in the preceding lemma. The only difference is that in (3.38), $F(V_{\bar{k},\bar{l}}^{\bar{m},\alpha})^* (\bar{\psi}_{\bar{k}} \boxtimes \bar{\psi}_{\bar{l}})$ appears in contrast to $F(V_{\bar{l},\bar{k}}^{\bar{m},\alpha})^* (\bar{\psi}_{\bar{l}} \boxtimes \bar{\psi}_{\bar{k}})$ in (3.30). But this is compensated for by the $\varepsilon(\gamma_{\bar{k}}, \gamma_{\bar{l}})$ in (3.41). ■

LEMMA 3.8. *The $*$ -operation of $\mathcal{C} \rtimes_0 \mathcal{S}$ is positive. Thus $\mathcal{C} \rtimes_0 \mathcal{S}$ is a C^* -tensor category.*

Proof. Let $\tilde{S} \in \text{Hom}_{\mathcal{C} \rtimes_0 \mathcal{S}}(\rho, \sigma)$. It is sufficient to prove that the vanishing of $(\tilde{S}^* \tilde{S})_e$, i.e., the component in (3.4) with $k = e$ (the G -invariant part, see below), implies $\tilde{S} = 0$. Let thus

$$S = \bigoplus_{k \in \hat{G}} \sum_i S_k^i \otimes \psi_k^i, \quad S_k^i \in \text{Hom}(\gamma_k \rho, \sigma), \psi_k \in \mathcal{H}_k. \quad (3.42)$$

(We must sum over an index i in order to allow for elements of $\text{Hom}_{\mathcal{C} \rtimes_0 \mathcal{S}}(\rho, \sigma)$ which are not simple tensors.) Then

$$\begin{aligned} (\tilde{S}^* \tilde{S})_e &= \sum_{k, l \in \hat{G}} \sum_{i, j} R_k^* \times \text{id}_\rho \circ \text{id}_{\gamma_{\bar{k}}} \times S_k^{i*} \circ \text{id}_{\gamma_{\bar{k}}} \times S_l^j \circ V_{k, l}^e \times \text{id}_\rho \\ &\quad \otimes F(V_{k, l}^e)^* (\langle \psi_k^i \boxtimes \cdot, F(\bar{R}_k) \Omega \rangle \boxtimes \psi_l^j). \end{aligned} \quad (3.43)$$

Now, the space $\text{Hom}(\gamma_e, \gamma_{\bar{k}} \gamma_l) = \text{Hom}(l, \gamma_{\bar{k}} \gamma_l)$ is one dimensional for $l = k$ and trivial otherwise. Since the choice of an orthonormal basis in this space does not matter we can choose $V_{k, k}^e = d(k)^{-1/2} R_k$. Here the numerical factor involving the dimension $d(k) = d(\gamma_k) > 0$ [19] is necessary in order for V to be isometric. Then

$$\begin{aligned} (\tilde{S}^* \tilde{S})_e &= \sum_{k \in \hat{G}} \frac{1}{d(k)} \sum_{i, j} R_k^* \times \text{id}_\rho \circ \text{id}_{\gamma_{\bar{k}}} \times (S_k^{i*} \circ S_k^j) \circ R_k \times \text{id}_\rho \\ &\quad \otimes F(R_k)^* (\langle \psi_k^i \boxtimes \cdot, F(\bar{R}_k) \Omega \rangle \boxtimes \psi_k^j). \end{aligned} \quad (3.44)$$

Considering the $\text{Hom}(\rho, \rho)$ -valued bilinear form on $\text{Hom}(\gamma_k \rho, \rho)$

$$(S, T) \mapsto \langle S, T \rangle_k = R_k^* \times \text{id}_\rho \circ \text{id}_{\gamma_{\bar{k}}} \times (S^* \circ T) \circ R_k \times \text{id}_\rho, \quad (3.45)$$

positivity of the $*$ -operation of \mathcal{C} implies that $\langle S, S \rangle_k = 0$ iff $\text{id}_{\gamma_{\bar{k}}} \times S \circ R_k \times \text{id}_\rho = 0$. By Frobenius reciprocity this is the case iff $S = 0$, thus $\langle \cdot, \cdot \rangle_k$ is positive definite. Furthermore,

$$\begin{aligned} &F(R_k)^* (\langle \psi_k^i \boxtimes \cdot, F(\bar{R}_k) \Omega \rangle \boxtimes \psi_k^j) \\ &= \langle \Omega, F(R_k)^* (\langle \psi_k^i \boxtimes \cdot, F(\bar{R}_k) \Omega \rangle \boxtimes \psi_k^j) \rangle \Omega \\ &= \langle F(R_k) \Omega, \langle \psi_k^i \boxtimes \cdot, F(\bar{R}_k) \Omega \rangle \boxtimes \psi_k^j \rangle \Omega \\ &= \langle \psi_k^i \boxtimes F(R_k) \Omega, F(\bar{R}_k) \Omega \boxtimes \psi_k^j \rangle \Omega \\ &= \langle \psi_k^i \boxtimes \Omega, F(\text{id}_{\gamma_k} \times R_k^* \circ \bar{R}_k \times \text{id}_{\gamma_k}) \Omega \boxtimes \psi_k^j \rangle \Omega \\ &= \langle \psi_k^i, \psi_k^j \rangle_{\mathcal{H}_k} \Omega, \end{aligned} \quad (3.46)$$

where we have used the conjugate equations. Thus also

$$(\tilde{S}^* \tilde{S})_e = \sum_{k \in \hat{G}} \frac{1}{d(k)} \sum_{i,j} \langle \psi_k^i, \psi_k^j \rangle_{\mathcal{H}_k} \langle S_k^i, S_k^j \rangle_k \otimes \Omega \quad (3.47)$$

is positive definite since it is the sum of the tensor product of such maps, and $\tilde{S}^* \tilde{S}$ vanishes iff $\tilde{S} = 0$. The second claim follows by Proposition 2.1. ■

Summing up we have proved

PROPOSITION 3.9. *$\mathcal{C} \rtimes_0 \mathcal{S}$ is a C^* -tensor category with conjugates and direct sums.*

Remark. If $\mathcal{S} \subset \mathcal{D}$ we can consider the crossed product $\mathcal{D} \rtimes_0 \mathcal{S}$, which is a full subcategory of $\mathcal{C} \rtimes_0 \mathcal{S}$. It is interesting to note that $\mathcal{D} \rtimes_0 \mathcal{S}$ can be defined also if $\mathcal{S} \not\subset \mathcal{D}$, namely as the full subcategory of $\mathcal{C} \rtimes_0 \mathcal{S}$ whose objects are those in \mathcal{D} . It is obvious that for $\mathcal{S} \subset \mathcal{D}$ this notation is consistent with the crossed product in the sense of Definition 2.1. Thus also for $\mathcal{S} \not\subset \mathcal{D}$ we obtain a C^* -tensor category $\mathcal{D} \rtimes_0 \mathcal{S}$ with conjugates and direct sums. It turns out, however, that we obtain nothing new in this way. For, by Frobenius reciprocity in C^* -tensor categories [19] we have $\dim \text{Hom}_{\mathcal{C}}(\gamma_k \rho, \sigma) = \dim \text{Hom}_{\mathcal{C}}(\gamma_k, \sigma \bar{\rho})$. In view of $\sigma \bar{\rho} \in \mathcal{S}$ we have $\text{Hom}_{\mathcal{C}}(\gamma_k \rho, \sigma) = \{0\}$ whenever $\gamma_k \notin \mathcal{S}$. Thus the direct sum in (3.4) effectively runs only over the k such that $\gamma_k \in \mathcal{D}$, which implies $\mathcal{D} \rtimes_0 \mathcal{S} = \mathcal{D} \rtimes_0 (\mathcal{D} \cap \mathcal{S})$. Therefore we are left with the crossed product of a symmetric tensor category by a full subcategory.

3.4. Braiding, Subobjects, and Uniqueness

LEMMA 3.10. *The braiding ε of \mathcal{C} lifts to a braiding for $\mathcal{C} \rtimes_0 \mathcal{S}$ iff $\mathcal{S} \subset \mathcal{D}$.*

Proof. Define $\tilde{\varepsilon}(\rho, \sigma) = \varepsilon(\rho, \sigma) \otimes \Omega \in \text{Hom}_{\mathcal{C} \rtimes_0 \mathcal{S}}(\rho \sigma, \sigma \rho)$. That $\tilde{\varepsilon}$ satisfies the relations

$$\tilde{\varepsilon}(\rho, \sigma_1 \sigma_2) = \text{id}_{\sigma_1} \times \tilde{\varepsilon}(\rho, \sigma_2) \circ \tilde{\varepsilon}(\rho, \sigma_1) \times \text{id}_{\sigma_2}, \quad (3.48)$$

$$\tilde{\varepsilon}(\rho_1 \rho_2, \sigma) = \tilde{\varepsilon}(\rho_1, \sigma) \times \text{id}_{\rho_2} \circ \text{id}_{\rho_1} \times \tilde{\varepsilon}(\rho_2, \sigma) \quad (3.49)$$

is obvious since these relations hold in \mathcal{C} . It remains to show that $\tilde{\varepsilon}$ is natural w.r.t. both variables also in the extended category. Assuming $\mathcal{S} \subset \mathcal{D}$ we will prove

$$\tilde{S} \times \text{id}_{\rho} \circ \tilde{\varepsilon}(\rho, \sigma) = \tilde{\varepsilon}(\rho, \eta) \circ \text{id}_{\rho} \times \tilde{S} \quad (3.50)$$

in $\mathcal{C} \rtimes_0 \mathcal{S}$ with $\tilde{S} \in \text{Hom}_{\mathcal{C} \rtimes_0 \mathcal{S}}(\sigma, \eta)$. The proof of naturality w.r.t. the other variable is similar, and the general result follows by the interchange law (3.18). Now, in more explicit terms the left hand side of (3.50) amounts to (with $S \in \text{Hom}(\gamma_k \sigma, \eta)$)

$$\begin{aligned} S \otimes \psi_k \times \text{id}_\rho \otimes \Omega \circ \varepsilon(\rho, \sigma) \otimes \Omega &= (S \times \text{id}_\rho) \otimes \psi_k \circ \varepsilon(\rho, \sigma) \otimes \Omega \\ &= S \times \text{id}_\rho \circ \text{id}_{\gamma_k} \times \varepsilon(\rho, \sigma) \otimes \psi_k \end{aligned} \quad (3.51)$$

and the right hand side to

$$\begin{aligned} \varepsilon(\rho, \eta) \otimes \Omega \circ \text{id}_\rho \otimes \Omega \times S \otimes \psi_k \\ = \varepsilon(\rho, \eta) \otimes \Omega \circ [\text{id}_\rho \times S \circ \varepsilon(\gamma_k, \rho) \times \text{id}_\sigma] \otimes \psi_k \\ = \varepsilon(\rho, \eta) \circ \text{id}_\rho \times S \circ \varepsilon(\gamma_k, \rho) \times \text{id}_\sigma \otimes \psi_k. \end{aligned} \quad (3.52)$$

That these expressions coincide is seen by the following calculation for the \mathcal{C} -parts.

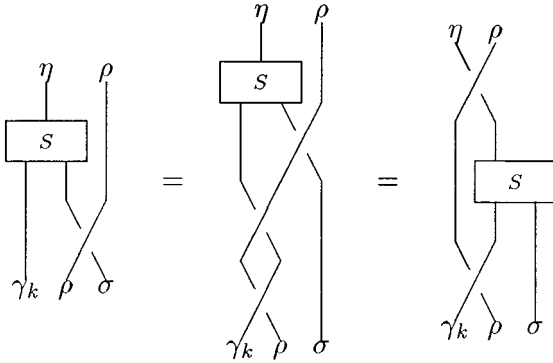

In the second step of this computation we have used the naturality of the braiding in \mathcal{C} , and the first step is legitimate if $\varepsilon_M(\gamma_k, \rho) = \text{id}_{\gamma_k \rho}$. This holds for all $\rho \in \mathcal{C}$ if $\mathcal{S} \subset \mathcal{D}$ since then all γ_k are degenerate. Now assume $\mathcal{S} \not\subset \mathcal{D}$, i.e., there is a $\gamma_k \in \mathcal{S}$ which has non-trivial monodromy with some $\rho \in \mathcal{C}$. Let now $\eta \prec \gamma_k \sigma$ and $S \in \text{Hom}(\gamma_k \sigma, \eta)$. Reversing the above argument we see that naturality of the braiding $\tilde{\varepsilon}(\rho, \sigma)$ in $\mathcal{C} \rtimes_0 \mathcal{S}$ fails for $\tilde{S} = S \otimes \psi_k \in \text{Hom}_{\mathcal{C} \rtimes_0 \mathcal{S}}(\sigma, \eta)$. ■

Remark. It is instructive to relate this result to what happens in the quantum field framework [24, 21]. There the observables \mathcal{A} are extended by fields implementing the sectors in a symmetric semigroup Δ of DHR endomorphisms and the localized sectors of \mathcal{A} are extended to the fields \mathcal{F} . If Δ contains non-degenerate sectors then the extension $\tilde{\rho}$ of at least one sector ρ is solitonic, i.e., localized only in a half-space. But it is well known that for solitons there is no braiding.

As observed in Remark 6 after Definition 3.1, the objects $\gamma_k \in \mathcal{S}$ decompose into multiples of ι in $\mathcal{C} \rtimes_0 \mathcal{S}$. But in $\mathcal{C} \rtimes_0 \mathcal{S}$ also other irreducible objects $\rho \in \mathcal{C}$ may become reducible in the sense that $\text{Hom}_{\mathcal{C} \rtimes_0 \mathcal{S}}(\rho, \rho) \supsetneq \mathbb{C} \text{id}_\rho$. In this case the subobjects are not already present in \mathcal{C} . Thus $\mathcal{C} \rtimes_0 \mathcal{S}$ will in general not be closed under subobjects. There is a canonical procedure [19, Appendix], yielding for every 2-category \mathcal{C} a 2-category $\bar{\mathcal{C}}$ which is closed under subobjects and contains \mathcal{C} as a full subcategory. Since we are concerned only with the special (and more familiar) case of tensor categories, we give a fairly explicit description below.

DEFINITION 3.11. The closure $\bar{\mathcal{C}}$ of a tensor category \mathcal{C} w.r.t. subobjects has as objects pairs (ρ, E) where $\rho \in \text{Obj } \mathcal{C}$ and $E = E^2 = E^* \in \text{Hom}_{\mathcal{C}}(\rho, \rho)$. The morphisms in $\bar{\mathcal{C}}$ are given by

$$\begin{aligned} \text{Hom}_{\bar{\mathcal{C}}}((\rho, E), (\sigma, F)) &= \{ T \in \text{Hom}_{\mathcal{C}}(\rho, \sigma) \mid T = T \circ E = F \circ T \} \\ &= F \circ \text{Hom}_{\mathcal{C}}(\rho, \sigma) \circ E, \end{aligned} \quad (3.54)$$

and the composition of morphisms, where defined, is the one of \mathcal{C} . The identity morphisms are given by $\text{id}_{(\rho, E)} = E$. The tensor product is $(\rho, E)(\sigma, F) = (\rho\sigma, E \times F)$ for the objects and the one of \mathcal{C} for the morphisms. The embedding of \mathcal{C} in $\bar{\mathcal{C}}$ is given by $\rho \mapsto (\rho, \text{id}_\rho)$ and the identity map on the arrows.

Remark. With this definition (ρ, E) is a subobject of $\rho = (\rho, \text{id}_\rho)$ in view of $E \in \text{Hom}((\rho, E), (\rho, \text{id}_\rho))$ and $E \circ E^* = E, E^* \circ E = E = \text{id}_{(\rho, E)}$. Assume a subobject $\rho_1 \prec \rho$ exists in \mathcal{C} with $V \in \text{Hom}_{\mathcal{C}}(\rho_1, \rho)$ isometric. Then ρ_1 is isomorphic in $\bar{\mathcal{C}}$ to (ρ, E) , where $E = V \circ V^*$. Indeed, on one hand $V \in \text{Hom}((\rho_1, \text{id}_{\rho_1}), (\rho, E))$ since $V = V \circ \text{id}_{\rho_1} = \text{id}_{(\rho, E)} \circ V = E \circ V = V \circ V^* \circ V = V$. On the other hand, V is unitary (in $\bar{\mathcal{C}}$!) since $V^* \circ V = \text{id}_{\rho_1}$ and $V \circ V^* = E = \text{id}_{(\rho, E)}$. If \mathcal{C} has conjugates then also $\bar{\mathcal{C}}$ has conjugates. For, if $\rho, \bar{\rho}, R, \bar{R}$ satisfy the conjugate equations, then $(\bar{\rho}, \bar{E})$ is a conjugate for (ρ, E) . Here

$$\bar{E} = R^* \times \text{id}_{\bar{\rho}} \circ \text{id}_{\bar{\rho}} \times E \times \text{id}_{\bar{\rho}} \circ \text{id}_{\bar{\rho}} \times \bar{R} \quad (3.55)$$

is easily verified to be an orthogonal projection in $(\bar{\rho}, \bar{\rho})$, and $R_{(\rho, E)} = \bar{E} \times E \circ R, \bar{R}_{(\rho, E)} = E \times \bar{E} \circ \bar{R}$ satisfy the conjugate equations. If \mathcal{C} is obtained from a subcategory \mathcal{C}_0 by adding morphisms, ρ is irreducible in \mathcal{C}_0 and $\bar{\rho}, R, \bar{R}$ is a solution of the conjugate equations in \mathcal{C}_0 then with the above it is easy to see that $\rho, \bar{\rho}, R, \bar{R}$ is a standard solution in $\bar{\mathcal{C}}$. Finally, given $V \in \text{Hom}(\rho, \tau), W \in \text{Hom}(\sigma, \tau)$ with $V \circ V^* + W \circ W^* = \text{id}_\tau$ (thus $\tau \cong \rho \oplus \sigma$) and given projections $E \in \text{Hom}(\rho, \rho), F \in \text{Hom}(\sigma, \sigma)$ it is easy to verify that $(\tau, V \circ E \circ V^* + W \circ F \circ W^*)$ is a direct sum of (ρ, E) and (σ, F) . Thus, if \mathcal{C} is closed w.r.t. subobjects then the obvious embedding functor $\mathcal{C} \rightarrow \bar{\mathcal{C}}$ is

essentially surjective. Since it is also full and faithful, \mathcal{C} and $\overline{\mathcal{C}}$ are equivalent as categories, cf. [20, Sect. IV.4]. That this is in fact an equivalence of tensor categories requires an additional argument for which we refer, e.g., to [34].

DEFINITION 3.12. $\mathcal{C} \rtimes \mathcal{S} = \overline{\mathcal{C} \rtimes_0 \mathcal{S}}$. \mathcal{C} is identified with a subcategory of $\mathcal{C} \rtimes \mathcal{S}$ via the embedding $\rho \mapsto (\rho, \text{id}_\rho)$, $\text{Hom}(\rho, \sigma) \ni S \mapsto S \otimes \Omega \in \text{Hom}((\rho, \text{id}_\rho), (\sigma, \text{id}_\sigma))$.

THEOREM 3.13. $\mathcal{C} \rtimes \mathcal{S}$ is a C^* -tensor category with conjugates, direct sums, and subobjects. If $\mathcal{S} \subset \mathcal{D}$ then $\mathcal{C} \rtimes \mathcal{S}$ is braided. If \mathcal{C} is rational then so is $\mathcal{C} \rtimes \mathcal{S}$.

Proof. As shown above, closing under subobjects does not affect the property of being closed under direct sums. Since an object ρ has the same finite dimension in $\mathcal{C} \rtimes \mathcal{S}$ as in \mathcal{C} , it decomposes into finitely many subobjects in $\mathcal{C} \rtimes \mathcal{S}$. Thus $\mathcal{C} \rtimes \mathcal{S}$ is rational if \mathcal{C} is. It only remains to prove that the braiding of $\mathcal{C} \rtimes_0 \mathcal{S}$ given by Lemma 3.10 if $\mathcal{S} \subset \mathcal{D}$ extends uniquely to the closure under subobjects. This was shown for symmetric tensor categories in [6] and works also in the braided case. We sketch the argument. Consider $\rho, \sigma \in \text{Obj } \mathcal{C} = \text{Obj } \mathcal{C} \rtimes_0 \mathcal{S}$ and $E \in \text{Hom}(\rho, \rho)$, $F \in \text{Hom}(\sigma, \sigma)$. Defining

$$\varepsilon((\rho, E), (\sigma, F)) = F \times E \circ \varepsilon(\rho, \sigma) \circ E \times F, \tag{3.56}$$

it is easily verified that we obtain a braiding for $\mathcal{C} \rtimes \mathcal{S}$ which satisfies naturality w.r.t. both variables. ■

PROPOSITION 3.14. Up to isomorphism of tensor categories, the category $\mathcal{C} \rtimes \mathcal{S}$ does not depend on the choice of the section $\{\gamma_l, l \in \hat{G}\}$ and of the functor F . If $\mathcal{S} \subset \mathcal{D}$ then this isomorphism respects the braiding.

Proof. Let $\{\gamma_k, k \in \hat{G}\}, \{\gamma'_k, k \in \hat{G}\}$ be two sections of \hat{G} in \mathcal{S} and let F, F' be functors embedding \mathcal{S} into the category of Hilbert spaces. Denote the corresponding categories by $\mathcal{C} \rtimes_0^{(\gamma, F)} \mathcal{S}, \mathcal{C} \rtimes_0^{(\gamma', F')} \mathcal{S}$. We know that there are unitaries $W_k \in \text{Hom}(\gamma_k, \gamma'_k)$ as well as a natural transformation $\{U_\rho: F(\rho) \rightarrow F'(\rho), \rho \in \hat{G}\}$ from F to F' with the U_ρ 's being unitaries. Then the linear maps $\text{Hom}_{\mathcal{C} \rtimes_0^{(\gamma, F)} \mathcal{S}}(\rho, \sigma) \rightarrow \text{Hom}_{\mathcal{C} \rtimes_0^{(\gamma', F')} \mathcal{S}}(\rho, \sigma)$ defined by

$$S \otimes \psi_k \mapsto S \circ W_k \times \text{id}_\rho \otimes U_k \psi_k, \quad S \in \text{Hom}(\gamma_k \rho, \sigma), \psi_k \in \mathcal{H}_k = F(\gamma_k) \tag{3.57}$$

are isomorphisms. The easy proof that these maps define a (braided) tensor $*$ -functor (obviously invertible) from $\mathcal{C} \rtimes_0^{(\gamma, F)} \mathcal{S}$ to $\mathcal{C} \rtimes_0^{(\gamma', F')} \mathcal{S}$ which is the

identity on the objects is left to the reader. Finally, isomorphic categories have isomorphic closures under subobjects. ■

Remark. The functor F is unique up to a natural transformation, the latter being in one-to-one correspondence to the elements of G . The role of the compact group G for the category $\mathcal{C} \rtimes \mathcal{S}$ we will thoroughly clarify in the next section.

3.5. G -Symmetry

By the DR duality theorem (or the Tannaka–Krein duality, taking the existence of a representation functor F for granted) the Hilbert spaces \mathcal{H}_k , $k \in \hat{G}$ carry unitary representations $\pi_k(\cdot)$ of G . We define an action of $G = \text{Gal}(\mathcal{S})$ on the morphisms of $\mathcal{C} \rtimes_0 \mathcal{S}$ and thus of $\mathcal{C} \rtimes \mathcal{S}$ by

$$\alpha_g(S \otimes \psi_k) = S \otimes \pi_k(g) \psi_k, \quad S \in \text{Hom}(\gamma_k \rho, \sigma). \quad (3.58)$$

For the objects (ρ, E) of $\mathcal{C} \rtimes \mathcal{S} = \overline{\mathcal{C} \rtimes_0 \mathcal{S}}$ we define

$$\alpha_g((\rho, E)) = (\rho, \alpha_g(E)), \quad (3.59)$$

where $\alpha_g(E)$ is defined in (3.58).

DEFINITION 3.15. Let $\mathcal{T} \subset \mathcal{S}$ be [B/S] TC*s. Then $\text{Aut}_{\mathcal{T}}(\mathcal{S})$ is the group of automorphisms (invertible [braided/symmetric] tensor *-endo-functors) of \mathcal{S} which leave \mathcal{T} stable.

LEMMA 3.16. *The map $g \mapsto \alpha_g$ is a homomorphism of G into $\text{Aut}_{\mathcal{T}}(\mathcal{C} \rtimes \mathcal{S})$.*

Proof. Using the definitions (3.5), (3.6) and the functoriality of F one easily verifies that

$$\alpha_g(\tilde{S} \bullet \tilde{T}) = \alpha_g(\tilde{S}) \bullet \alpha_g(\tilde{T}), \quad \text{where } \bullet \in \{ \circ, \times \}. \quad (3.60)$$

In order to show that α_g is a functor it remains to show that $T \in \text{Hom}_{\mathcal{C} \rtimes \mathcal{S}}((\rho, E), (\sigma, F))$ implies

$$\alpha_g(T) \in \text{Hom}_{\mathcal{C} \rtimes \mathcal{S}}(\alpha_g((\rho, E)), \alpha_g((\sigma, F))). \quad (3.61)$$

This is true due to $\alpha_g(T) \in \text{Hom}_{\mathcal{C} \rtimes_0 \mathcal{S}}(\rho, \sigma)$ and

$$\alpha_g(T) = \alpha_g(T) \circ \alpha_g(E) = \alpha_g(F) \circ \alpha_g(T), \quad (3.62)$$

where we have used (3.60). α_g is a tensor functor since (3.60) for $\bullet = \times$ implies

$$\alpha_g((\rho, E)(\sigma, F)) = (\rho\sigma, \alpha_g(E \times F)) = \alpha_g((\rho, E)) \alpha_g((\sigma, F)). \quad (3.63)$$

Finally, saying that α_g is a braided tensor functor is equivalent to the equation

$$\alpha_g(\varepsilon((\rho, E), (\sigma, F))) = \varepsilon(\alpha_g((\rho, E)), \alpha_g((\sigma, F))), \quad (3.64)$$

which follows immediately from (3.56) and the G -invariance of $\varepsilon(\rho, \sigma)$. The homomorphism property of $g \mapsto \alpha_g$ is obvious and thus also the invertibility of α_g . Clearly, α_g acts trivially on \mathcal{C} . ■

PROPOSITION 3.17. *For every $\alpha \in \text{Aut}_{\mathcal{C}}(\mathcal{C} \rtimes \mathcal{S})$ there is $g \in G = \text{Gal}(\mathcal{S})$ such that $\alpha = \alpha_g$. Thus $\text{Aut}_{\mathcal{C}}(\mathcal{C} \rtimes \mathcal{S}) \cong \text{Gal}(\mathcal{S})$.*

Proof. Let $\alpha \in \text{Aut}_{\mathcal{C}}(\mathcal{C} \rtimes \mathcal{S})$. Then $\alpha(\rho) = \rho$ for $\rho \in \mathcal{C}$ implies $\alpha(T) \in \text{Hom}_{\mathcal{C} \rtimes \mathcal{S}}(\rho, \sigma)$ if $T \in \text{Hom}_{\mathcal{C} \rtimes \mathcal{S}}(\rho, \sigma)$. As before, we write $\tilde{T} = T \otimes \psi_k$ with $T \in \text{Hom}_{\mathcal{C}}(\gamma_k \rho, \sigma)$, $\psi_k \in \mathcal{H}_k$ also as $T \circ \psi_k \times \text{id}_{\rho}$, where ψ_k is interpreted as an element of $\text{Hom}_{\mathcal{C} \rtimes \mathcal{S}}(i, \gamma_k)$. Then $\alpha(\tilde{T}) = T \circ \alpha(\psi_k) \times \text{id}_{\rho}$ since α acts trivially on the morphisms in \mathcal{C} . Thus α is determined by the actions on the Hilbert spaces \mathcal{H}_k , which are clearly linear. Due to $\alpha(\psi^* \psi') = \psi^* \psi' \circ \text{id}_i \in \mathcal{C}$ for $\psi, \psi' \in \mathcal{H}_k$ these actions are unitary, which then is true for all spaces $\text{Hom}_{\mathcal{C} \rtimes \mathcal{S}}(i, \gamma)$. If $\gamma, \gamma' \in \mathcal{S}$, $V \in \text{Hom}_{\mathcal{C}}(\gamma, \gamma')$ and $\psi \in F(\gamma)$ then $\psi' = F(V) \psi \in F(\gamma')$ and $\alpha(\psi') = F(V) \alpha(\psi)$. Thus α acts on the spaces $\text{Hom}(i, \gamma)$, $\gamma \in \mathcal{S}$ like a natural transformation of the functor $F: \mathcal{S} \rightarrow \mathcal{H}$ to itself. But the latter are in one-to-one correspondence to the elements of $G = \text{Gal}(\mathcal{S})$ [6]. ■

From now on we identify $G = \text{Aut}_{\mathcal{C}}(\mathcal{C} \rtimes \mathcal{S})$.

DEFINITION 3.18. Let $H \subset G$ be a subgroup. Then $(\mathcal{C} \rtimes \mathcal{S})^H$ is the sub-tensor category of $\mathcal{C} \rtimes \mathcal{S}$ consisting of H -invariant objects and morphisms. (That this really is a tensor category follows from the functoriality of α_g .)

LEMMA 3.19. $(\mathcal{C} \rtimes \mathcal{S})^G$ is equivalent to \mathcal{C} .

Proof. A morphism $T \in \text{Hom}_{\mathcal{C} \rtimes \mathcal{S}}((\rho, E), (\sigma, F)) \subset \text{Hom}_{\mathcal{C} \rtimes \mathcal{S}}(\rho, \sigma)$ is G -invariant iff it is in $\text{Hom}_{\mathcal{C}}(\rho, \sigma)$. An object (ρ, E) of $\mathcal{C} \rtimes \mathcal{S}$ is in $(\mathcal{C} \rtimes \mathcal{S})^G$ iff E is G -invariant iff $E \in \text{Hom}_{\mathcal{C}}(\rho, \rho)$. Thus $(\mathcal{C} \rtimes \mathcal{S})^G$ is isomorphic to the closure $\overline{\mathcal{C}}$ of \mathcal{C} under subobjects. The latter is equivalent to \mathcal{C} since \mathcal{C} is by assumption closed w.r.t. subobjects. (Recall the remark following Definition 3.11.) ■

Remarks. (1) The fact that $(\mathcal{C} \rtimes \mathcal{S})^{\text{Aut}_{\mathcal{C}}(\mathcal{C} \rtimes \mathcal{S})} \simeq \mathcal{C}$ justifies calling $\mathcal{C} \subset \mathcal{C} \rtimes \mathcal{S}$ a Galois extension of BTC*'s. This line of thought will be continued in Subsection 4.2.

(2) If $\rho \in \mathcal{C}$ is irreducible then $\text{Hom}_{\mathcal{C} \rtimes \mathcal{S}}(\rho, \rho)^G = \text{Hom}_{\mathcal{C}}(\rho, \rho) = \mathbb{C} \text{id}_\rho$, thus G acts ergodically on $\text{Hom}_{\mathcal{C} \rtimes \mathcal{S}}(\rho, \rho)$. Now for irreducible $\rho \in \mathcal{C}$ the obvious dimension consideration

$$\dim \text{Hom}_{\mathcal{C}}(\gamma_k \rho, \rho) \leq d_k \quad \forall k \in \hat{G} \quad (3.65)$$

together with (3.4) implies that the irreducible representation π_k of $G = \text{Gal}(\mathcal{S})$ occurs in $\text{Hom}_{\mathcal{C} \rtimes \mathcal{S}}(\rho, \rho)$ with multiplicity at most d_k (equivalently, the corresponding spectral subspace has dimension at most d_k^2). This is an instance of a well-known general result in the theory of ergodic compact group actions on von Neumann algebras, cf. [12, Proposition 2.1; 31, I].

4. GALOIS CORRESPONDENCE AND THE MODULAR CLOSURE

Throughout the section \mathcal{C} is BTC*, $\mathcal{S} \subset \mathcal{C}$ is a STC*, and $G = \text{Aut}_{\mathcal{C}}(\mathcal{C} \rtimes \mathcal{S}) \cong \text{Gal}(\mathcal{S})$. Having defined the semidirect product $\mathcal{C} \rtimes \mathcal{S}$ and established its uniqueness, we will now prove some non-trivial properties. We continue to assume \mathcal{S} to be even and will make clear which results require $\mathcal{S} \subset \mathcal{D}$.

4.1. The Modular Closure $\mathcal{C} \rtimes \mathcal{D}$

The following technical lemma can be distilled from [31, I, Sect. 11], but we give the easy direct proof.

LEMMA 4.1. *Let N be a finite dimensional semisimple \mathbb{C} -algebra and let $g \mapsto \alpha_g \in \text{Aut } N$ be an ergodic action of a group G . Then N is isomorphic to the tensor product of its center $Z(N)$ with a full matrix algebra,*

$$N \cong M_n \otimes Z(N) \cong \underbrace{M_n \oplus M_n \oplus \cdots \oplus M_n}_{d \text{ terms}}, \quad (4.1)$$

where $d = \dim Z(N)$ and M_n denotes the simple algebra of complex $n \times n$ matrices. Let E, F be minimal (i.e., one dimensional) projections in N . Then there is $g \in G$ such that $\alpha_g(E) \cong_N F$, i.e., there is $V \in N$ such that $VV^* = F$, $V^*V = \alpha_g(E)$.

Proof. Let E be a projection in N . Since N is a von Neumann algebra it contains the projection $\bar{E} = \bigvee_{g \in G} \alpha_g(E)$, which clearly is non-trivial and G -invariant. Therefore $\bar{E} \in N^G = \mathbb{C}\mathbf{1}$ and thus $\bar{E} = \mathbf{1}$. Applying this to the (finite) set of minimal projections in $Z(N)$ we see that G acts transitively on the set of minimal central projections of N . Since the dimension of such

a projection is invariant under an automorphism of N , all simple blocks of N have the same rank.

Let E, F be minimal projections in N and let \tilde{E}, \tilde{F} be the (unique) minimal projections in $Z(N)$ such that $E \leq \tilde{E}, F \leq \tilde{F}$. Then there is $g \in G$ such that $\alpha_g(\tilde{E}) = \tilde{F}$, thus $\alpha_g(E) \leq \tilde{F}$. This implies $\alpha_g(E) \cong_N F$ since all one dimensional projections in the factor $\tilde{F}N$ are equivalent. ■

PROPOSITION 4.2. *Let $\rho \in \mathcal{C}$ be irreducible. Then all irreducible subobjects ρ_i of ρ in $\mathcal{C} \rtimes \mathcal{S}$ occur with the same multiplicity and have the same dimension. If $\mathcal{S} \subset \mathcal{D}$, thus $\mathcal{C} \rtimes \mathcal{S}$ is braided, then all ρ_i have the same twist as ρ , and they are either all degenerate or all non-degenerate according to whether ρ is degenerate or non-degenerate.*

Proof. $\text{Hom}_{\mathcal{C} \rtimes \mathcal{S}}(\rho, \rho)$ is a finite dimensional von Neumann algebra and $\text{Hom}_{\mathcal{C} \rtimes \mathcal{S}}(\rho, \rho)^G = \text{Hom}_{\mathcal{C}}(\rho, \rho) = \mathbb{C} \text{id}_\rho$. Thus the lemma applies and the first claim of the proposition follows from the result that all simple blocks of $\text{Hom}_{\mathcal{C} \rtimes \mathcal{S}}(\rho, \rho)$ have the same rank. Let $E, F \in \text{Hom}_{\mathcal{C} \rtimes \mathcal{S}}(\rho, \rho)$ be minimal projections corresponding to the irreducible subobjects $(\rho, E), (\rho, F)$ of ρ and let g, V be as in the lemma. Then $(\rho, \alpha_g(E))$ is equivalent to (ρ, F) since V is a unitary in $\text{Hom}_{\mathcal{C} \rtimes \mathcal{S}}((\rho, \alpha_g(E)), (\rho, F))$. The dimension of ρ being defined [19] via $d_\rho \text{id}_i = R_\rho^* \circ R_\rho$ and $R_{(\rho, E)}$ being given as in the remark after Definition 3.11, the independence of $d_{(\rho, E)}$ on E follows from the transitivity of the G -action on the set of minimal central projections.

Assuming now $\mathcal{S} \subset \mathcal{D}$ it follows similarly that the twist is the same for all subobjects. If $\{V_i \in \text{Hom}(\rho_i, \rho)\}$ is a family of isometries such that $V_i^* \circ V_j = \delta_{i,j} \text{id}_{\rho_i}$ and $\sum_i V_i \circ V_i^* = \text{id}_\rho$ where the ρ_i are irreducible in $\mathcal{C} \rtimes \mathcal{S}$, then $\kappa(\rho) = \sum_i V_i \circ \kappa(\rho_i) \circ V_i^*$. Since $\kappa(\rho_i) = \omega \text{id}_{\rho_i}$ for some $\omega \in \mathbb{C}$, this implies $\kappa(\rho) = \omega \text{id}_\rho$ and thus $\omega(\rho) = \omega(\rho_i) \forall i$. Since α_g is a braided tensor functor (3.64), (ρ, E) is degenerated iff $(\rho, \alpha_g(E)) \cong (\rho, F)$ is degenerate. Thus the subobjects ρ_i are either all degenerate or all non-degenerate. Since an object is degenerate iff all subobjects are degenerate, cf. Proposition 2.7, we conclude that the subobjects are degenerate iff ρ is degenerate. ■

Remark. That the decomposition of a degenerate object yields only degenerate objects was known before, cf. Proposition 2.7, and for degenerate ρ the result on the multiplicities and dimensions of the irreducible subobjects reduces to a well known result on group representations, as will be shown in the next subsection. But for the non-degenerate objects, which have no group theoretic interpretation, the above result is new and crucial for the rest of the paper. A detailed analysis of how an irreducible non-degenerate object of \mathcal{C} decomposes in $\mathcal{C} \rtimes \mathcal{S}$ will be given in Subsection 5.1 for the case where $\text{Gal}(\mathcal{S})$ is an abelian group.

COROLLARY 4.3. *If $\mathcal{S} \subset \mathcal{D}$ then $\mathcal{D}(\mathcal{C} \rtimes \mathcal{S}) \cong \mathcal{D} \rtimes \mathcal{S}$.*

Proof. We have to show that starting from \mathcal{C} the operations of taking the crossed product with \mathcal{S} and of picking the full subcategory of degenerate objects commute. Now we observe

$$\mathcal{D}(\mathcal{C} \rtimes \mathcal{S}) = \mathcal{D}(\overline{\mathcal{C} \rtimes_0 \mathcal{S}}) \cong \overline{\mathcal{D}(\mathcal{C} \rtimes_0 \mathcal{S})} \cong \overline{\mathcal{D} \rtimes_0 \mathcal{S}} = \mathcal{D} \rtimes \mathcal{S}, \quad (4.2)$$

where the equalities hold by definition. The first isomorphism follows since an irreducible subobject (ρ, E) of ρ is degenerate iff ρ is degenerate, and the second isomorphism is true since $\mathcal{D}(\mathcal{C} \rtimes_0 \mathcal{S}) = \mathcal{D} \rtimes_0 \mathcal{S}$. ■

Even though further machinery will be developed below, we are already in a position to state one of our main results, which in fact provided the motivation for the entire paper.

THEOREM 4.4. *$\mathcal{C} \rtimes \mathcal{D}$ is non-degenerate. Thus every irreducible degenerate object is equivalent to ι . If $\mathcal{C} \rtimes \mathcal{D}$ is rational (which follows if \mathcal{C} is rational) then $\mathcal{C} \rtimes \mathcal{D}$ is modular.*

Proof. By the proposition we have $\mathcal{D}(\mathcal{C} \rtimes \mathcal{D}) \cong \mathcal{D} \rtimes \mathcal{D}$. Now, all objects of $\mathcal{D} \rtimes_0 \mathcal{D}$ are multiples of the identity, cf. Remark 6 after Definition 3.1. Thus there are no irreducible degenerate objects in $\mathcal{C} \rtimes \mathcal{D}$ which are inequivalent to ι . The rest follows from the discussion in Section 2. ■

This result motivates the following

DEFINITION 4.5. The modular closure of a braided tensor $*$ -category with conjugates, direct sums, and subobjects is $\overline{\mathcal{C}} = \mathcal{C} \rtimes \mathcal{D}$.

The terminology *closure* is justified by the fact that $\mathcal{D}(\overline{\mathcal{C}})$ is trivial, which implies that the modular closure $\overline{\mathcal{C}}$ does not admit further crossed products (with braiding).

4.2. Galois Correspondence

Turning now to the study of categories \mathcal{E} sitting between \mathcal{C} and $\mathcal{C} \rtimes \mathcal{S}$ we begin with those of the form $(\mathcal{C} \rtimes \mathcal{S})^H$ where $H \subset G$.

LEMMA 4.6. *Let $H \subset G$ be a subgroup and let \overline{H} be its closure in G . Then $(\mathcal{C} \rtimes \mathcal{S})^H = (\mathcal{C} \rtimes \mathcal{S})^{\overline{H}}$ is a $[B]TC^*$.*

Proof. That the fixpoint categories under H and \overline{H} are the same follows from continuity of π_k in (3.58). If $E \in \text{Hom}_{\mathcal{C} \rtimes \mathcal{S}}(\rho, \rho)$ is H -invariant then also \overline{E} defined in (3.55) is H -invariant, thus $(\mathcal{C} \rtimes \mathcal{S})^H$ has conjugates. That $(\mathcal{C} \rtimes \mathcal{S})^H$ has direct sums and subobjects is seen similarly. In order to

prove closedness of $(\mathcal{C} \rtimes \mathcal{S})^H$ under the $*$ -operation we have to show that T^* is H -invariant if T is. In view of (3.7) we have

$$\alpha_g((S \otimes \psi_k)^*) = R_k^* \times \text{id}_\rho \circ \text{id}_{\gamma_k} \times S^* \otimes \pi_{\bar{k}}(g) \langle \psi_k \boxtimes \cdot, F(\bar{R}_k) \Omega \rangle. \quad (4.3)$$

That $(S \otimes \psi_k)^*$ is H -invariant follows from the following calculation with $g \in H$ and $\psi_k \in \mathcal{H}_k^H$,

$$\begin{aligned} \pi_{\bar{k}}(g) \langle \psi_k \boxtimes \cdot, F(\bar{R}_k) \Omega \rangle &= \langle \psi_k \boxtimes \cdot, \pi_k(g) \times \pi_{\bar{k}}(g) F(\bar{R}_k) \Omega \rangle \\ &= \langle \psi_k \boxtimes \cdot, F(\bar{R}_k) \pi_0(g) \Omega \rangle \\ &= \langle \psi_k \boxtimes \cdot, F(\bar{R}_k) \Omega \rangle. \end{aligned} \quad (4.4)$$

We have used that $\{\pi_k(g), k \in \hat{G}\}$ is a natural transformation of F and that π_0 is the trivial representation. The restriction of the braiding of $\mathcal{C} \rtimes \mathcal{S}$ to $(\mathcal{C} \rtimes \mathcal{S})^H$ is, of course, a braiding. ■

In order to prove that all TC*’s between \mathcal{C} and $\mathcal{C} \rtimes \mathcal{S}$ are of the form $(\mathcal{C} \rtimes \mathcal{S})^H$ we need the following

LEMMA 4.7. *Let \mathcal{E} be a TC* such that $\mathcal{C} \subset \mathcal{E} \subset \mathcal{C} \rtimes \mathcal{S}$. With the identification of the Hilbert spaces $\mathcal{H}_k = F(\gamma_k)$ and $\text{Hom}_{\mathcal{C} \rtimes \mathcal{S}}(l, \gamma_k) = \text{Hom}(\gamma_k, \gamma_k) \otimes \mathcal{H}_k$ via $\psi_k \mapsto \text{id}_{\gamma_k} \otimes \psi_k$ we have*

$$\text{Hom}_{\mathcal{E}}(\rho, \sigma) = \bigoplus_{k \in \hat{G}} \text{Hom}_{\mathcal{E}}(\gamma_k \rho, \sigma) \otimes \text{Hom}_{\mathcal{E}}(l, \gamma_k). \quad (4.5)$$

Thus the subspaces $\text{Hom}_{\mathcal{E}}(\rho, \sigma) \subset \text{Hom}_{\mathcal{C} \rtimes \mathcal{S}}(\rho, \sigma)$ for all $\rho, \sigma \in \mathcal{C}$ are determined by the subspaces $\text{Hom}_{\mathcal{E}}(l, \gamma_k) \subset \text{Hom}_{\mathcal{C} \rtimes \mathcal{S}}(l, \gamma_k)$.

Proof. In the entire proof let $\rho, \sigma \in \mathcal{C}$ be fixed. With the above identification of \mathcal{H}_k and $\text{Hom}_{\mathcal{C} \rtimes \mathcal{S}}(l, \gamma_k)$ we can rewrite (3.4) as

$$\text{Hom}_{\mathcal{C} \rtimes \mathcal{S}}(\rho, \sigma) = \bigoplus_{k \in \hat{G}} \text{Hom}_{\mathcal{E}}(\gamma_k \rho, \sigma) \otimes \text{Hom}_{\mathcal{C} \rtimes \mathcal{S}}(l, \gamma_k). \quad (4.6)$$

If $\text{id}_{\gamma_k} \otimes \psi \in \text{Hom}_{\mathcal{C} \rtimes \mathcal{S}}(l, \gamma_k)$ is contained in $\text{Hom}_{\mathcal{E}}(l, \gamma_k)$ and $S \in \text{Hom}(\gamma_k \rho, \sigma)$ then $S \otimes \psi = S \otimes \Omega \circ \text{id}_{\gamma_k} \otimes \psi \in \text{Hom}_{\mathcal{E}}(\rho, \sigma)$, since $S \in \text{Hom } \mathcal{C} \subset \text{Hom } \mathcal{E}$. Thus in (4.5) we have the inclusion \supset . Now we define positive definite scalar products $\langle \cdot, \cdot \rangle_k$ on $\text{Hom}_{\mathcal{E}}(\gamma_k \rho, \sigma)$ for all $k \in \hat{G}$ as

$$S, T \mapsto \langle S, T \rangle_k \text{id}_{\gamma_k} = \text{id}_{\gamma_k} \times \bar{R}_\rho^* \circ (S^* \circ T) \times \text{id}_{\bar{\rho}} \circ \text{id}_{\gamma_k} \times \bar{R}_\rho. \quad (4.7)$$

We have used that γ_k is irreducible, thus $\text{Hom}(\gamma_k, \gamma_k) \cong \mathbb{C} \text{id}_{\gamma_k}$. (Positive definiteness is seen as follows: $\langle S, S \rangle = 0$ implies $\text{id}_{\gamma_k} \times \bar{R}_\rho^* \circ (S^* \circ S) \times \text{id}_{\bar{\rho}} \circ \text{id}_{\gamma_k} \times \bar{R}_\rho = 0$. By positivity of the $*$ -operation this implies $S \times \text{id}_{\bar{\rho}} \circ \text{id}_{\gamma_k} \times \bar{R}_\rho = 0$ and using the conjugate equation this entails $S = 0$.) For every $k \in \hat{G}$ pick an orthonormal basis $\{W_i^k, i = 1, \dots, \dim \text{Hom}(\gamma_k \rho, \sigma)\}$ in the Hilbert

spaces $\text{Hom}(\gamma_k \rho, \sigma)$. Every $\tilde{S} \in \text{Hom}_{\mathcal{C} \rtimes \mathcal{S}}(\rho, \sigma)$ is of the form $\tilde{S} = \bigoplus_{l \in \hat{G}} \sum_j S_j^l \otimes \psi_j^l$, where $S_j^l \in \text{Hom}(\gamma_l \rho, \sigma)$ and $\psi_j^l \in \mathcal{H}_l$. Using the above discussion this can be expressed as

$$\begin{aligned}
 \tilde{S} &= \bigoplus_{l \in \hat{G}} \sum_j \left(\sum_i \langle W_i^l, S_j^l \rangle W_i^l \right) \otimes \psi_j^l \\
 &= \sum_{l \in \hat{G}} \sum_j \sum_i \langle W_i^l, S_j^l \rangle W_i^l \circ \text{id}_{\gamma_l} \otimes \psi_j^l \times \text{id}_\rho \\
 &= \sum_{l \in \hat{G}} \sum_j \sum_i W_i^l \circ (\text{id}_{\gamma_l} \times \bar{R}_\rho^* \circ (W_i^{l*} \circ S_j^l) \times \text{id}_{\bar{\rho}} \circ \text{id}_{\gamma_l} \times \bar{R}_\rho) \circ \text{id}_{\gamma_l} \otimes \psi_j^l \times \text{id}_\rho \\
 &= \sum_{k, l \in \hat{G}} \sum_j \sum_i W_i^l \circ (\text{id}_{\gamma_l} \times \bar{R}_\rho^* \circ (W_i^{l*} \circ S_j^k) \times \text{id}_{\bar{\rho}} \circ \text{id}_{\gamma_k} \times \bar{R}_\rho) \\
 &\quad \circ \text{id}_{\gamma_k} \otimes \psi_j^k \times \text{id}_\rho \\
 &= \sum_{l \in \hat{G}} \sum_i W_i^l \circ (\text{id}_{\gamma_l} \times \bar{R}_\rho^* \circ (W_i^{l*} \circ \tilde{S}) \times \text{id}_\rho) \\
 &= \bigoplus_{l \in \hat{G}} \sum_i W_i^l \otimes \Psi_i^l,
 \end{aligned} \tag{4.8}$$

where

$$\Psi_i^l = \text{id}_{\gamma_l} \times \bar{R}_\rho^* \circ (W_i^{l*} \circ \tilde{S}) \times \text{id}_\rho \circ \bar{R}_\rho \in \text{Hom}_{\mathcal{C} \rtimes \mathcal{S}}(l, \gamma_k). \tag{4.9}$$

In the second step we have used $S \otimes \psi^l = S \circ \psi^l \times \text{id}_\rho$. The fourth equality is true since the big bracket is in $\text{Hom}_{\mathcal{C}}(\gamma_k, \gamma_l)$, which vanishes for $k \neq l$. In the fifth step we used the interchange law (in $\mathcal{C} \rtimes \mathcal{S}$) as in the following diagram and performed the summations over k and j . Now we have

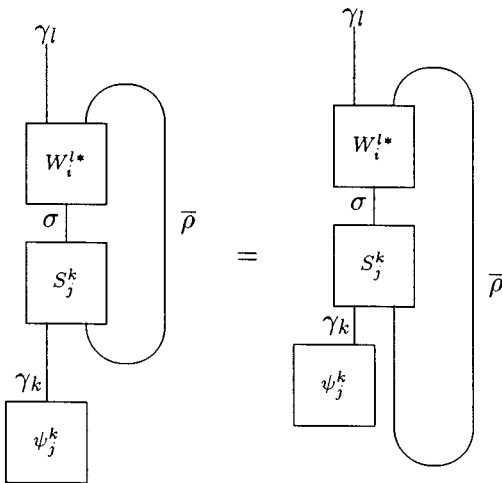

and if $\tilde{S} \in \text{Hom}_{\mathcal{E}}(l, \gamma_l)$ then also $\Psi_i^l \in \text{Hom}_{\mathcal{E}}(l, \gamma_l)$ since W_i^l and \bar{R}_ρ are morphisms in \mathcal{C} , thus in \mathcal{E} . This proves the inclusion \subset in (4.5). ■

PROPOSITION 4.8. *Let \mathcal{E} be a TC* such that $\mathcal{C} \subset \mathcal{E} \subset \mathcal{C} \rtimes \mathcal{S}$. Then $\mathcal{E} = (\mathcal{C} \rtimes \mathcal{S})^H$ where $H = \text{Aut}_{\mathcal{E}}(\mathcal{C} \rtimes \mathcal{S})$ is a closed subgroup of $G = \text{Aut}_{\mathcal{C}}(\mathcal{C} \rtimes \mathcal{S})$.*

Proof. Let \mathcal{F} be the full subcategory of \mathcal{E} defined by $\text{Obj } \mathcal{F} = \text{Obj } \mathcal{E} \cap \text{Obj } \mathcal{S} \rtimes \mathcal{S}$, i.e. $(\rho, E) \in \mathcal{E}$ is in \mathcal{F} iff $\rho \in \mathcal{S}$. Then we have the diagram

$$\begin{array}{ccc} \mathcal{C} & \subset & \mathcal{E} & \subset & \mathcal{C} \rtimes \mathcal{S} \\ \cup & & \cup & & \cup \\ \mathcal{S} & \subset & \mathcal{F} & \subset & \mathcal{S} \rtimes \mathcal{S} \end{array} \tag{4.10}$$

Here all vertical inclusions are full and all categories in the lower row are symmetric. ($\mathcal{S} \rtimes \mathcal{S}$ is symmetric since it is the closure under subobjects of $\mathcal{S} \times_0 \mathcal{S}$. The latter is a symmetric tensor category since \mathcal{S} —though not necessarily contained in $\mathcal{D}(\mathcal{C})$ —is trivially contained in $\mathcal{D}(\mathcal{S}) = \mathcal{S}$, entailing that the symmetric braiding of \mathcal{S} lifts to $\mathcal{S} \times_0 \mathcal{S}$.) Fixing a DR representation functor $F: \mathcal{S} \rightarrow \mathcal{H}$, where \mathcal{H} is the symmetric tensor category of finite dimensional Hilbert spaces, we define G to be the group of natural automorphisms of F and have $\text{Aut}_{\mathcal{S}}(\mathcal{S} \rtimes \mathcal{S}) \cong \text{Aut}_{\mathcal{C}}(\mathcal{C} \rtimes \mathcal{S}) \cong G$. Defining $H = \text{Aut}_{\mathcal{F}}(\mathcal{S} \rtimes \mathcal{S}) \subset G$, the proposition follows easily as soon as we prove

$$\mathcal{F} = (\mathcal{S} \rtimes \mathcal{S})^H \tag{4.11}$$

since this implies $\text{Hom}_{\mathcal{F}}(l, \gamma) = \text{Hom}_{\mathcal{S} \rtimes \mathcal{S}}(l, \gamma)^H$, $\gamma \in \mathcal{S}$ and by Lemma 4.7 we have $\text{Hom}_{\mathcal{E}}(\rho, \sigma) = \text{Hom}_{\mathcal{C} \rtimes \mathcal{S}}(\rho, \sigma)^H$ for all $\rho, \sigma \in \mathcal{C}$. Since \mathcal{E} is supposed closed under subobjects this implies $(\rho, E) \in \text{Obj } \mathcal{E}$ if the projection $E \in \text{Hom}_{\mathcal{C} \rtimes \mathcal{S}}(\rho, \rho)$ is H -invariant. On the other hand, $(\rho, E) \in \text{Obj } \mathcal{E}$ implies $E \in \text{Hom } \mathcal{E}$ since $E = \text{id}_{(\rho, E)}$ and \mathcal{E} is a category. Thus $(\rho, E) \in \text{Obj } \mathcal{E}$ iff $E \in \text{Hom}_{\mathcal{C} \rtimes \mathcal{S}}(\rho, \rho)^H$ and therefore $\mathcal{E} = (\mathcal{C} \rtimes \mathcal{S})^H$. Thus we are left with the proof of (4.11).

Choose a section $\{\gamma_k, k \in \hat{G}\}$ of irreducibles in $\mathcal{S} \cong U(G)$. We begin by showing that F extends to a functor $\hat{F}: \mathcal{S} \times_0 \mathcal{S} \rightarrow \mathcal{H}$. For $S \in \text{Hom}(\gamma_k \rho, \sigma)$, $\psi \in \mathcal{H}_k$ we recall that $S \otimes \psi \in \text{Hom}_{\mathcal{S} \times_0 \mathcal{S}}(\rho, \sigma)$ and define $\hat{F}(S \otimes \psi): F(\rho) \rightarrow F(\sigma)$ by

$$\hat{F}(S \otimes \psi)(\phi) = F(S)(\psi \boxtimes \phi), \quad \phi \in F(\rho). \tag{4.12}$$

This makes sense since $\psi \boxtimes \phi \in F(\gamma_k) \boxtimes F(\rho)$ and the latter Hilbert space is canonically isomorphic to $F(\gamma_k \rho)$. By definition \hat{F} coincides with F on the objects, and it is easy to see that the same is true on the morphisms $\text{Hom}_{\mathcal{S}}(\rho, \sigma)$ of \mathcal{S} . We have to show that \hat{F} is a symmetric tensor

-functor, i.e., compatible with the operations \circ , \times , $$. We do this only for \circ and leave the other arguments to the reader. Let $S \in \text{Hom}(\gamma_k \sigma, \eta)$, $T \in \text{Hom}(\gamma_l \rho, \sigma)$, $\psi_k \in \mathcal{H}_k$, $\psi_l \in \mathcal{H}_l$ and $\phi \in \mathcal{H}_\rho = F(\rho)$. We have to show that

$$\hat{F}(S \otimes \psi_k \circ T \otimes \psi_l) \phi = \hat{F}(S \otimes \psi_k) \circ \hat{F}(T \otimes \psi_l) \phi \quad \forall \phi \in \mathcal{H}_\rho. \quad (4.13)$$

The right hand side equals

$$\begin{aligned} \hat{F}(S \otimes \psi_k) F(T)(\psi_l \boxtimes \phi) &= F(S)(\psi_k \boxtimes F(T)(\psi_l \boxtimes \phi)) \\ &= F(S \circ \text{id}_{\gamma_k} \times T)(\psi_k \boxtimes \psi_l \boxtimes \phi), \end{aligned} \quad (4.14)$$

and is seen to coincide with the left hand side

$$\begin{aligned} \hat{F} \left(\bigoplus_{m \in \hat{G}} \sum_{\alpha=1}^{N_{k,l}^m} S \circ \text{id}_{\gamma_k} \times T \circ V_{k,l}^{m,\alpha} \times \text{id}_\rho \otimes F(V_{k,l}^{m,\alpha})^* (\psi_k \boxtimes \psi_l) \right) \phi \\ = \bigoplus_{m \in \hat{G}} \sum_{\alpha=1}^{N_{k,l}^m} F(S \circ \text{id}_{\gamma_k} \times T \circ V_{k,l}^{m,\alpha} \times \text{id}_\rho) (F(V_{k,l}^{m,\alpha})^* (\psi_k \boxtimes \psi_l) \boxtimes \phi) \end{aligned} \quad (4.15)$$

appealing to the completeness relation for the bases $\{V_{k,l}^{m,\alpha}\}$. The extension of \hat{F} to the new objects (ρ, E) , $E \not\leq \text{id}_\rho$ of $\mathcal{S} \rtimes \mathcal{S} = \mathcal{S} \rtimes_0 \mathcal{S}$ is obvious: $\hat{F}((\rho, E)) = \hat{F}(E) \hat{F}(\rho)$, the right hand side being a subspace of the Hilbert space $\hat{F}(\rho) = F(\rho)$. The functor $\hat{F}: \mathcal{S} \rtimes \mathcal{S} \rightarrow \mathcal{H}$ thus obtained is a symmetric tensor *-functor and thus a DR representation functor. Furthermore, $\hat{F} \upharpoonright \mathcal{F}$ is a representation functor for \mathcal{F} , and $\text{Gal}(\mathcal{F})$ is the set of natural transformations of $\hat{F} \upharpoonright \mathcal{F}$, i.e., the set of families of unitary maps $\{U_{(\rho, E)} \in F \text{Hom}((\rho, E), (\rho, E)), (\rho, E) \in \mathcal{F}\}$ such that

$$U_{(\sigma, F)} \circ F(\tilde{S}) = F(\tilde{S}) \circ U_{(\rho, E)} \quad (4.16)$$

for all $(\rho, E), (\sigma, F) \in \mathcal{F}$, $\tilde{S} \in \text{Hom}_{\mathcal{F}}((\rho, E), (\sigma, F))$. Since \mathcal{F} contains \mathcal{S} , a natural transformation of $\hat{F} \upharpoonright \mathcal{F}$ restricts to one of $F: \{U_{(\rho, \text{id}_\rho)}, \rho \in \mathcal{S}\}$. Now, the group of natural automorphisms of F is just the Galois group $G = \text{Gal}(\mathcal{C})$. Let $g \in G$ and let $\{U_{(\rho, \text{id}_\rho)} = \pi_\rho(g), \rho \in \mathcal{S}\}$ be the corresponding natural transformation. A necessary condition for the latter to arise from a natural transformation of $\hat{F} \upharpoonright \mathcal{F}$ is that (4.16) holds for all ρ, σ , $\tilde{S} \in \text{Hom}_{\mathcal{F}}(\rho, \sigma)$. The corresponding $g \in G$ clearly constitute a subgroup $H \subset G$. In order to study this subgroup let $\tilde{S} \in \text{Hom}_{\mathcal{F}}(\rho, \sigma) \subset \text{Hom}_{\mathcal{S} \rtimes \mathcal{S}}(\rho, \sigma)$. With

$$\tilde{S} = \bigoplus_{i \in \hat{G}} \sum_i S_k^i \otimes \psi_k^i, \quad S_k^i \in \text{Hom}(\gamma_k \rho, \sigma), \psi_k \in \mathcal{H}_k \quad (4.17)$$

and the definition of \hat{F} we have

$$\hat{F}\left(\bigoplus_{k \in \hat{G}} \sum_i S_k^i \otimes \psi_k^i\right) \phi = \sum_{k \in \hat{G}} \sum_i F(S_k^i)(\psi_k^i \boxtimes \phi). \tag{4.18}$$

Then (4.16) takes the form

$$\begin{aligned} \sum_{k \in \hat{G}} \sum_i F(S_k^i)(\psi_k^i \boxtimes \pi_\rho(g) \phi) &= \pi_\sigma(g) \sum_{k \in \hat{G}} \sum_i F(S_k^i)(\psi_k^i \boxtimes \phi) \\ &= \sum_{k \in \hat{G}} \sum_i F(S_k^i)(\pi_k(g) \psi_k^i \boxtimes \pi_\rho(g) \phi). \end{aligned} \tag{4.19}$$

Since the subspaces $\text{Hom}(\gamma_k \rho, \sigma) \otimes \mathcal{H}_k$ for different k are linearly independent, this is true iff $\alpha_g(\tilde{\mathcal{S}}) = \tilde{\mathcal{S}}$. Since this must hold for all arrows $\tilde{\mathcal{S}}$ in \mathcal{F} we define

$$H = \{g \in G \mid \alpha_g(\tilde{\mathcal{S}}) = \tilde{\mathcal{S}} \quad \forall \tilde{\mathcal{S}} \in \mathcal{F}\}, \tag{4.20}$$

which is a closed subgroup of G . For $g \in H$, $U_{(\rho, \text{id}_\rho)} = \pi_\rho(g)$ commutes with the projections $E \in \text{Hom}_{\mathcal{F}}(\rho, \rho)$, and $U_{(\rho, E)} = U_{(\rho, \text{id}_\rho)} \upharpoonright E\mathcal{H}_\rho$ is a natural transformation of $\hat{F} \upharpoonright \mathcal{F}$. Thus $\text{Gal}(\mathcal{F}) \cong H$, and by the duality theorem we know that \mathcal{F} is a category of representations of H . Thus for $T \in \text{Hom}_{\mathcal{S} \rtimes \mathcal{S}}(\rho, \sigma)$ the linear operator $\hat{F}(T): F(\rho) \rightarrow F(\sigma)$ is contained in $\hat{F}(\text{Hom}_{\mathcal{F}}(\rho, \sigma))$ iff it intertwines the representations π_ρ and π_σ . By the above this is equivalent to T being H -invariant and therefore we have $\text{Hom}_{\mathcal{F}}(\rho, \sigma) = \text{Hom}_{\mathcal{S} \rtimes \mathcal{S}}(\rho, \sigma)^H$ for $\rho, \sigma \in \mathcal{S}$. For the subobjects (ρ, E) the argument at the beginning of the proof applies and we obtain $\mathcal{F} = (\mathcal{S} \rtimes \mathcal{S})^H$. ■

Now we consider the question for which subgroups $H \subset G$ there is a subcategory $\mathcal{T} \subset \mathcal{S}$ such that $(\mathcal{C} \rtimes \mathcal{S})^H \cong \mathcal{C} \rtimes \mathcal{T}$. We begin with three lemmas.

LEMMA 4.9. *Let G be a compact group and let π be an irreducible unitary representation on the Hilbert space \mathcal{H} . Let H be a closed normal subgroup of G . Then the subspace $\mathcal{H}^H \subset \mathcal{H}$ of H -invariant vectors is either $\{0\}$ or \mathcal{H} .*

Proof. Let $\psi \in \mathcal{H}$ be H -invariant. The normality of H implies that the vectors $\pi(g)\psi$, $g \in G$ are H -invariant, too. But the span of the latter is \mathcal{H} , since otherwise it would be a non-trivial G -invariant subspace, which does not exist by irreducibility of π . ■

LEMMA 4.10. *Let G be compact and H be a closed normal subgroup. Then there is a one-to-one correspondence between the (i) continuous unitary*

representations π of G/H and (ii) continuous unitary representations $\hat{\pi}$ of G such that $H \subset \ker \hat{\pi}$. This correspondence restricts to irreducible representations. An intertwiner between representations π, π' lifts to $\hat{\pi}, \hat{\pi}'$ and vice versa.

Proof. Let $\phi: G \rightarrow G/H$ be the quotient homomorphism. Then the correspondences are given by $\pi \mapsto \hat{\pi} = \pi \circ \phi$ and $\hat{\pi} \mapsto \pi = \hat{\pi} \circ \phi^{-1}$, where the latter is well-defined since $\hat{\pi}$ is constant on cosets. These constructions respect continuity since ϕ is continuous and open. The statement on intertwiners is obvious. ■

The following is not explicitly contained in [6], but a part of the results is contained in the more general [6, Theorem 6.10].

LEMMA 4.11. *Let \mathcal{S} be a STC* with $\text{Gal}(\mathcal{S}) \cong G$. Pick a representation functor F of Doplicher and Roberts which identifies \mathcal{S} with a category $U(G)$ of representations of G and let π_ρ be the action of G on the Hilbert space $F(\rho)$. For a closed normal subgroup H of G the full subcategory of \mathcal{S} defined by $\text{Obj } \mathcal{T}_H = \{\rho \in \mathcal{S} \mid H \subset \ker \pi_\rho\}$ is a replete full symmetric subcategory with conjugates, etc., and $\text{Gal}(\mathcal{T}_H) \cong G/H$. The map $H \mapsto \mathcal{T}_H$ is bijective, the inverse being given by $\mathcal{T} \mapsto H_\mathcal{T} = \{h \in G \mid h \in \ker \pi_\rho, \forall \rho \in \mathcal{T}\}$. (In these considerations the non-uniqueness of the functor F is unimportant since the kernel of the representation π_ρ does not depend on the choice of F .)*

Proof. Given a closed normal subgroup H , define $\mathcal{T}_H \subset \mathcal{S}$ as given. The braiding and the $*$ -operation restrict to \mathcal{T}_H , which is also closed under conjugates, direct sums, and subobjects. For $\rho \in \mathcal{T}_H$, Lemma 4.10 gives rise to a representation of G/H on $F(\rho)$, and $F(T)$ where $\rho, \sigma \in \mathcal{T}_H, T \in \text{Hom}(\rho, \sigma)$ intertwines the representations of G/H on $F(\rho), F(\sigma)$. Since $U(G) = F(\mathcal{S})$ is complete in the sense that for every $g \in G$ there is a $\rho \in \mathcal{S}$ such that $F(\rho)(g) \neq \mathbf{1}$, the same holds for \mathcal{T}_H and G/H , which implies $\text{Gal}(\mathcal{T}_H) \cong G/H$. On the other hand, given $\mathcal{T}, H_\mathcal{T}$ clearly is a closed normal subgroup of G , and we have to show that this map is inverse to $H \mapsto \mathcal{T}_H$. Obviously, $H \subset H_{\mathcal{T}_H}$ and $\mathcal{T} \subset \mathcal{T}_{H_\mathcal{T}}$. By the above, $F(\mathcal{T}_H)$ can be looked at as a complete category of representations of G/H . Thus $g \in G$ is in $H_{\mathcal{T}_H}$ iff $\bar{g} = \bar{e}$ (where $\bar{g} = \phi(g)$ is the image of g in G/H) iff $g \in H$, whence $H_{\mathcal{T}_H} = H$. For given $\mathcal{T} \subset \mathcal{S}$, F restricts to an embedding functor for \mathcal{T} , and $\text{Gal}(\mathcal{T})$ is (isomorphic to) the group of natural transformations of $F \upharpoonright \mathcal{T}$ to itself. Since $g \in \text{Gal}(\mathcal{S})$ is trivial as a natural transformation of $F \upharpoonright \mathcal{T}$ iff $g \in H_\mathcal{T}$ we have a homomorphism of $G/H_\mathcal{T}$ into $\text{Gal}(\mathcal{T})$. Since the map $\phi: G \rightarrow G/H_\mathcal{T}$ is surjective we have in fact an isomorphism $\text{Gal}(\mathcal{T}) \cong G/H_\mathcal{T}$. Comparing this with $\text{Gal}(\mathcal{T}_{H_\mathcal{T}}) \cong G/H_{\mathcal{T}_{H_\mathcal{T}}} = G/H_\mathcal{T}$, where we have used $H_{\mathcal{T}_{H_\mathcal{T}}} = H$, this implies $\mathcal{T} \simeq \mathcal{T}_{H_\mathcal{T}}$. Since $\mathcal{T}, \mathcal{T}_{H_\mathcal{T}}$ are replete full subcategories of \mathcal{S} we have $\mathcal{T} = \mathcal{T}_{H_\mathcal{T}}$. ■

PROPOSITION 4.12. *Given $\mathcal{C} \subset \mathcal{E} \subset \mathcal{C} \rtimes \mathcal{S}$ where $\mathcal{E} \simeq (\mathcal{C} \rtimes \mathcal{S})^H$, the subgroup $H \subset G$ is normal iff there is a STC* $\mathcal{T} \subset \mathcal{S}$ such that $\mathcal{E} \cong \mathcal{C} \rtimes \mathcal{T}$. In this case $\text{Aut}_{\mathcal{E}}(\mathcal{C} \rtimes \mathcal{S}) = H$ and $\text{Aut}_{\mathcal{E}}(\mathcal{E}) \cong G/H$.*

Proof. Let H be a normal subgroup of G . Pick a functor $F_{\mathcal{S}}$ identifying \mathcal{S} with a category $U(G)$ of representations of G . Let $\mathcal{T}_H \subset \mathcal{S}$ be the full subcategory corresponding to H . $F_{\mathcal{S}}$ restricts to \mathcal{T}_H , and when comparing $\mathcal{C} \rtimes \mathcal{S}$, $\mathcal{C} \rtimes \mathcal{T}_H$ we will choose the functors $F_{\mathcal{S}}$, $F_{\mathcal{S}} \upharpoonright \mathcal{T}_H$ in the construction of the crossed products.

By definition $(\mathcal{C} \rtimes \mathcal{S})^H \cong \mathcal{C} \rtimes \mathcal{T}_H$ is the subcategory of $\mathcal{C} \rtimes \mathcal{S}$ whose objects and arrows are H -invariant. In view of (3.4) and (3.58) this means for $\rho, \sigma \in \mathcal{C}$ that

$$\begin{aligned} \text{Hom}_{(\mathcal{C} \rtimes \mathcal{S})^H}(\rho, \sigma) &= \bigoplus_{k \in \hat{G}} \text{Hom}(\gamma_k \rho, \sigma) \otimes \mathcal{H}_k^H \\ &= \bigoplus_{\substack{k \in \hat{G} \\ H \subset \ker \pi_k}} \text{Hom}(\gamma_k \rho, \sigma) \otimes \mathcal{H}_k, \end{aligned} \tag{4.21}$$

where in the second step we have applied Lemma 4.9. On the other hand

$$\text{Hom}_{\mathcal{C} \rtimes \mathcal{T}_H}(\rho, \sigma) = \bigoplus_{k \in \widehat{G/H}} \text{Hom}(\gamma_k \rho, \sigma) \otimes \mathcal{H}_k, \tag{4.22}$$

where \mathcal{H}_k now carries an irreducible representation of G/H . By Lemma 4.10 there is a canonical one-to-one correspondence between $k \in \widehat{G/H}$ and $k \in \hat{G}$, $H \subset \ker \pi_k$. Choosing the same γ_k 's in (4.22) as in (4.21) we can identify the right hand sides of (4.21) and (4.22), and the products \circ, \times on the arrows of $(\mathcal{C} \rtimes \mathcal{S})^H$ and $\mathcal{C} \rtimes \mathcal{T}_H$ are the same since $F_{\mathcal{T}_H}$ is the restriction of $F_{\mathcal{S}}$ to \mathcal{T}_H . In view of $\text{Hom}_{(\mathcal{C} \rtimes \mathcal{S})^H}(\rho, \rho) = \text{Hom}_{\mathcal{C} \rtimes \mathcal{T}_H}(\rho, \rho)$ also the objects of $(\mathcal{C} \rtimes \mathcal{S})^H$ can be identified with those of $\mathcal{C} \rtimes \mathcal{T}_H$. Thus $(\mathcal{C} \rtimes \mathcal{S})^H \cong \mathcal{C} \rtimes \mathcal{T}_H$. The preceding argument depended on choosing $F_{\mathcal{S}} \upharpoonright \mathcal{T}_H$ for the definition of $\mathcal{D} \rtimes \mathcal{T}_H$. But by Proposition 3.14 another choice of $F_{\mathcal{T}_H}$ yields an isomorphic crossed product category. Conversely, consider $\mathcal{T} \subset \mathcal{S}$ where $\text{Gal}(\mathcal{S}) \cong G = \text{Aut}_{\mathcal{E}}(\mathcal{C} \rtimes \mathcal{S})$. Then there is a normal subgroup $H_{\mathcal{T}}$ of G such that $\text{Gal}(\mathcal{T}) \cong G/H$, and it is easy to verify that $\mathcal{C} \rtimes \mathcal{T} \cong (\mathcal{C} \rtimes \mathcal{S})^{H_{\mathcal{T}}}$. ■

The preceding results were of a relative nature, classifying intermediate extensions \mathcal{E} such that $\mathcal{C} \subset \mathcal{E} \subset \mathcal{C} \rtimes \mathcal{S}$, where $\mathcal{S} \subset \mathcal{D}$ was not assumed. The following result clarifies the role of the absolute Galois groups for extensions $\mathcal{C} \rtimes \mathcal{S}$ where $\mathcal{S} \subset \mathcal{D}$.

PROPOSITION 4.13. For $\mathcal{S} \subset \mathcal{D}$ we have $\text{Gal}(\mathcal{C} \rtimes \mathcal{S}) \cong \text{Aut}_{\mathcal{C} \rtimes \mathcal{S}}(\mathcal{C} \rtimes \mathcal{D}) \cong H_{\mathcal{S}}$.

Proof. By Corollary 4.3 we have $\mathcal{D}(\mathcal{C} \rtimes \mathcal{S}) \cong \mathcal{D} \rtimes \mathcal{S}$. That the compact group associated to the STC* $\mathcal{D} \rtimes \mathcal{S}$ is $H_{\mathcal{S}}$ follows from the proof of Proposition 4.8. ■

Remarks. (1) In particular, for $\mathcal{S} = \mathcal{D}$ we have $\text{Gal}(\mathcal{S}) = \text{Gal}(\mathcal{C}) = \text{Gal}(\mathcal{D})$ and thus $\text{Gal}(\mathcal{C} \rtimes \mathcal{D}) = \mathbf{1}$, which was the statement of Theorem 4.4.

(2) Let \mathcal{C} be symmetric, i.e., $\mathcal{D} = \mathcal{C}$ with $\text{Gal}(\mathcal{C}) \cong G$. Then taking the crossed product $\mathcal{C} \rtimes \mathcal{S}$ with $\mathcal{S} \subset \mathcal{D}$ and $\text{Gal}(\mathcal{S}) \cong G/H$ amounts to restricting the representations in $U(G) \cong \mathcal{C}$ to the normal subgroup H . Then the statement of Proposition 4.2 on the equality of multiplicities and dimensions is nothing but the well known result [3, Section 49]. Namely given an irreducible representation π of G all irreducible representations of H in $\pi \upharpoonright H$ occur with the same multiplicity and have the same dimensions.

The preceding results make the analogy with algebraic field extensions $K \supset F$ obvious. Also these can be iterated until one arrives at the algebraic closure \bar{F} . The latter is the unique (up to F -isomorphism) algebraic extension in which all polynomials split into linear factors with the consequence that further algebraic extensions do not exist. Furthermore, there is a one-to-one relation between intermediate Galois extensions $K, \bar{F} \supset K \supset F$ and closed normal subgroups H of the absolute Galois group of F , given by $H \mapsto \bar{F}^H, K \mapsto \text{Aut}_K \bar{F}$.

Observe that the analogy with the algebraic closure—of course—not quite perfect since $\bar{\mathcal{C}}$ may have less irreducible objects than \mathcal{C} or be even trivial:

PROPOSITION 4.14. $\mathcal{C} \rtimes \mathcal{S}$ is trivial—in the sense that all irreducible objects are equivalent to the identity object ι —iff $\mathcal{S} = \mathcal{D} = \mathcal{C}$. Equivalently, \mathcal{C} is completely degenerate, i.e., symmetric, and $\mathcal{S} = \mathcal{C}$.

Proof. If \mathcal{S} is strictly smaller than \mathcal{D} then $\mathcal{C} \rtimes \mathcal{S}$ by the above contains degenerate objects which are inequivalent to ι . Thus assume $\mathcal{S} = \mathcal{D}$. The irreducible objects of $\mathcal{C} \rtimes \mathcal{D}$ are obtained by decomposing those of \mathcal{C} . We have seen that the degenerate objects of \mathcal{C} become multiples of the identity in $\mathcal{C} \rtimes \mathcal{D}$. But the decomposition in $\mathcal{C} \rtimes \mathcal{D}$ of a non-degenerate object of \mathcal{C} yields non-degenerate objects, which are inequivalent to ι . ■

COROLLARY 4.15. $\bar{\mathcal{C}} = \mathcal{C} \rtimes \mathcal{D}$ is non-trivial iff \mathcal{C} contains at least one non-degenerate object.

5. FURTHER DIRECTIONS

5.1. Abelian Groups G

In this subsection we consider the special case where all irreducible objects in \mathcal{S} have dimension one, which is equivalent to $\text{Gal}(\mathcal{S})$ being abelian. Our aim will be to give an explicit description of the sector structure of $\mathcal{C} \rtimes \mathcal{S}$, where a *sector* is a unitary isomorphism class of objects. (Abusing notation we write γ, ρ , etc., for objects and for the corresponding sectors.)

Denoting by Δ the set of irreducible sectors of \mathcal{C} , the tensor product and braiding in \mathcal{C} render Δ an abelian semigroup. Δ decomposes into the set $\Delta_{\mathcal{S}}$ of sectors in \mathcal{S} and the complement Δ' . Under the above assumption of one-dimensionality $K \equiv \Delta_{\mathcal{S}}$ is a discrete abelian group and the compact DR group is just the Pontrjagin dual $G = \hat{K}$. Given an irreducible $\gamma \in K$ and an irreducible $\rho \in \Delta'$, $\gamma\rho$ is irreducible (in \mathcal{C}) due to $d_{\gamma} = 1$ and Frobenius reciprocity $\text{Hom}(\gamma\rho, \gamma\rho) \cong \text{Hom}(\rho, \rho) \cong \mathbb{C}$. Another use of Frobenius reciprocity [21, Lemma 3.9] shows that $\gamma\rho$ is in Δ' . Thus the sectors in K act on those in Δ' by permutation, which implies that Δ' decomposes into K -orbits $\underline{\rho} := \{\gamma\rho, \gamma \in K\}$. Given irreducible $\rho_1, \rho_2 \in \Delta$, (3.4) implies that ρ_1, ρ_2 are unitarily equivalent in $\mathcal{C} \rtimes \mathcal{S}$ iff ρ_1, ρ_2 are in the same orbit (i.e., $\underline{\rho_1} = \underline{\rho_2}$) and disjoint otherwise. Thus in order to find all sectors in $\mathcal{C} \rtimes \mathcal{S}$ it suffices to consider one element ρ of each orbit $\underline{\rho}$ and to decompose it into irreducibles. Since $\mathcal{C} \rtimes \mathcal{S}$ is closed under direct sums and subobjects the decomposition of ρ is governed by the semisimple algebra $\text{Hom}_{\mathcal{C} \rtimes \mathcal{S}}(\rho, \rho)$. It is well known that

$$\text{Hom}_{\mathcal{C} \rtimes \mathcal{S}}(\rho, \rho) \cong \bigoplus_{i \in I} M_{N_i} \quad \Rightarrow \quad \rho = \bigoplus_{i \in I} N_i \rho_i. \tag{5.1}$$

Here M_d is the full matrix algebra of rank d , thus dimension d^2 , and the ρ_i are pairwise inequivalent irreducible sectors, occurring with multiplicity N_i .

Now we work out explicitly the structure of $\text{Hom}_{\mathcal{C} \rtimes \mathcal{S}}(\rho, \rho)$. Motivated by (3.4) and the fact that the spaces $\text{Hom}(\gamma_k \rho, \rho)$ are either zero or one dimensional we define

$$K_{\rho} = \{k \in K, \gamma_k \rho \cong \rho\}, \tag{5.2}$$

which clearly is a subgroup of K . By Remark 1 after Definition 3.1, K is finite. Choosing unitary intertwiners $T_k \in \text{Hom}(\gamma_k \rho, \rho)$, $k \in K_{\rho}$ and normalized vectors $\psi_k \in \mathcal{H}_k$, $\text{Hom}_{\mathcal{C} \rtimes \mathcal{S}}(\rho, \rho)$ is spanned by $\{T_k \otimes \psi_k, k \in K_{\rho}\}$ and we have

$$T_k \otimes \psi_k \circ T_l \otimes \psi_l = T_k \circ \text{id}_{\gamma_k} \times T_l \circ V_{k,l}^{kl} \times \text{id}_{\rho} \otimes F(V_{k,l}^{kl})^* (\psi_k \boxtimes \psi_l). \tag{5.3}$$

Now

$$T_k \circ \text{id}_{\gamma_k} \times T_l \circ V_{k,l}^{kl} \times \text{id}_\rho \in \text{Hom}(\gamma_{kl}\rho, \rho), \tag{5.4}$$

and since $\text{Hom}(\gamma_{kl}\rho, \rho)$ is one dimensional we have $T_k \circ \text{id}_{\gamma_k} \times T_l \circ V_{k,l}^{kl} \times \text{id}_\rho \propto T_{kl}$. Similarly, $F(V_{k,l}^{kl})^*(\psi_k \boxtimes \psi_l)$ is a unit vector in \mathcal{H}_{kl} , thus proportional to ψ_{kl} . Therefore

$$T_k \otimes \psi_k \circ T_l \otimes \psi_l = c(k, l) T_{kl} \otimes \psi_{kl}, \tag{5.5}$$

where associativity implies c to be a 2-cocycle in $Z^2(K_\rho, \mathbb{T})$, and $\text{Hom}_{\mathcal{G} \times \mathcal{S}}(\rho, \rho)$ is the twisted group algebra $\mathbb{C}^c K_\rho$. (This result could also have been derived from the general theory of ergodic actions of compact abelian groups on von Neumann algebras, cf., e.g., [1].) Due to $T_e \in \text{Hom}(\rho, \rho) \in \mathbb{C} \text{id}_\rho$ we can choose $T_e = \text{id}_\rho$, which will always be assumed in the sequel. Now we need some group theoretical results.

LEMMA 5.1. *Let A be a finite abelian group and $c \in Z^2(A, \mathbb{T})$. Then the center of the twisted group algebra $\mathbb{C}^c A = \text{span}\{U_k, k \in A\}$ with $U_k U_l = c(k, l) U_{kl}$ is spanned by $\{U_k, k \in B\}$, where*

$$B = \{k \in A \mid c(k, l) = c(l, k) \forall l \in B\} \tag{5.6}$$

is a subgroup of A . In fact, $Z(\mathbb{C}^c A) \cong \mathbb{C}B \cong \mathbb{C}(\hat{B})$. The twisted group algebra $\mathbb{C}^c A$ is isomorphic to the tensor product of its center with a full matrix algebra,

$$\mathbb{C}^c A \cong M_N \otimes \mathbb{C}(\hat{B}) \cong \underbrace{M_N \oplus M_N \oplus \cdots \oplus M_N}_{|B| \text{ terms}}$$

where $N = \sqrt{|A|/|B|}$. The minimal projections of the center are labeled by the elements of the dual group \hat{B} and under the canonical action of the dual group \hat{A} they are permuted according to

$$\alpha_g(P_\chi) = P_{\bar{g}\chi}, \tag{5.8}$$

where $\bar{g} \in \hat{B}$ is the restriction of the character $g \in \hat{A}$ to the subgroup $B \subset A$.

Proof. The twisted group algebra $\mathbb{C}^c A$ is a von Neumann algebra. This can be shown by explicitly exhibiting a positive $*$ -operation or by considering $\mathbb{C}^c A$ as a twisted product of the von Neumann algebra \mathbb{C} with A . Since the canonical action of the dual group \hat{A} on $\mathbb{C}^c A$ given by $\alpha_g(U_k) = \langle g, k \rangle U_k$ is ergodic, Lemma 4.1 applies and gives the result on the tensor

product structure of the twisted group algebra. The claim on the center follows by specialization to an abelian group A of well-known results on the center of twisted group algebras, cf. [15], or by an easy direct proof. That B is a subgroup of A is then obvious in view of (5.5) and the fact that the center is a subalgebra. Now, in restriction to B the cocycle c is symmetric, which is equivalent to $c \upharpoonright B$ being a coboundary,

$$c(k, l) = \frac{f(kl)}{f(k)f(l)} \quad \forall k, l \in B. \tag{5.9}$$

With the replacement $U_k \rightarrow f(k) U_k, k \in B$ the cocycle disappears on B and we have $Z(\mathbb{C}^c A) \cong B$. By Pontrjagin duality this is isomorphic to $\mathbb{C}(\hat{B})$ and the minimal projections in the center are given by

$$P_\chi = \frac{1}{|B|} \sum_{k \in B} \chi(k) U_k, \tag{5.10}$$

where $\chi \in \hat{B}$ is a character of B . From this formula it is obvious that the action of \hat{A} permutes these projections as stated. ■

Applying Lemma 5.1 to ρ with $A = K_\rho$ and $U_k = T_k \otimes \psi_k$, we define L_ρ to be the group B of the lemma and obtain

PROPOSITION 5.2. *In $\mathcal{C} \rtimes \mathcal{S}$ the object $\rho \in \mathcal{C}$ decomposes according to*

$$\rho \cong N_\rho \bigoplus_{\chi \in \widehat{L}_\rho} \rho^\chi, \tag{5.11}$$

where the $\rho^\chi, \chi \in \widehat{L}_\rho$ are irreducible, mutually inequivalent and all occur with the same multiplicity $N_\rho = \sqrt{|K_\rho|/|L_\rho|}$. The automorphism group G of $\mathcal{C} \rtimes \mathcal{S}$ permutes the subsectors according to $\alpha_g(\rho^\chi) \cong \rho^{\bar{g}\chi}$. Here $\bar{g} \in L_\rho$ is the restriction of $g \in G = \hat{K}$, considered as a character on K , to the subgroup $L_\rho \subset K_\rho \subset K$.

Remark. The result that all irreducible components of ρ appear with the same multiplicity N_ρ appears as the (unproved) assumption of “fixpoint homogeneity” in conformal field theory, cf. [9].

COROLLARY 5.3. *The irreducible sectors (isomorphism classes of irreducible objects) of $\mathcal{C} \rtimes \mathcal{S}$ are labeled by pairs $(\underline{\rho}, \chi)$. Here $\underline{\rho} \in \Delta/\Delta_\mathcal{S}$ is an orbit of irreducibles in Δ under the action of the group $\Delta_\mathcal{S}$ of degenerate sectors by multiplication and χ is a character of the subgroup $L_{\underline{\rho}} \subset K_{\underline{\rho}}$.*

5.2. Remarks on the Case $\mathcal{S} \not\subset \mathcal{D}$

Whereas the definition of $\mathcal{C} \rtimes \mathcal{D}$ does not require $\mathcal{S} \subset \mathcal{D}$, we have seen that only under this condition the braiding ε of \mathcal{C} gives rise to a braiding for $\mathcal{C} \rtimes \mathcal{S}$. Even though this was without importance for the larger part of Section 4 we remark that also in the case $\mathcal{S} \not\subset \mathcal{D}$ one can obtain braided tensor categories, which is of relevance for the applications to conformal quantum field theory, in particular the theory of modular invariants, as well as to subfactor theory.

If $\mathcal{S} \not\subset \mathcal{D}$ we can still obtain a *braided* semidirect product if we replace \mathcal{C} by the replete full subcategory $\mathcal{C}_{\mathcal{S}}$ which is defined by

$$\text{Obj } \mathcal{C}_{\mathcal{S}} = \{ \rho \in \mathcal{C} \mid \varepsilon_M(\rho, \gamma) = \text{id}_{\rho\gamma} \forall \gamma \in \mathcal{S} \}. \quad (5.12)$$

This set is easily seen to be closed under isomorphism, tensor products, conjugates, direct sums, and subobjects. Since \mathcal{S} is symmetric we clearly have $\mathcal{C}_{\mathcal{S}} \supset \mathcal{S}$, and by definition $\mathcal{S} \subset \mathcal{D}(\mathcal{C}_{\mathcal{S}})$. Thus $\mathcal{C}_{\mathcal{S}}$ satisfies all assumptions and we can construct $\mathcal{C}_{\mathcal{S}} \rtimes \mathcal{S}$, which is a non-trivial braided tensor category unless $\mathcal{C}_{\mathcal{S}} = \mathcal{S}$. (It may be instructive to compare $\mathcal{D}(\mathcal{C})$ with the center $Z(M)$ of a von Neumann algebra M , \mathcal{S} with an abelian subalgebra $A \subset M$ and $\mathcal{C}_{\mathcal{S}}$ with the relative commutant $M \cap A'$. Then $\mathcal{C}_{\mathcal{S}} = \mathcal{S}$ corresponds to $M \cap A' = A$, i.e., A maximal abelian in M .) By the preceding discussion $\mathcal{C}_{\mathcal{S}} \rtimes \mathcal{S}$ will be non-degenerate iff $\mathcal{S} = \mathcal{D}(\mathcal{C}_{\mathcal{S}})$, which can of course be enforced by replacing \mathcal{S} by $\mathcal{D}(\mathcal{C}_{\mathcal{S}})$. This makes clear that given a pair $(\mathcal{C}, \mathcal{S})$ where \mathcal{C} is a BTC* with \mathcal{S} a symmetric subcategory and setting

$$\mathcal{C}' = \mathcal{C}_{\mathcal{S}}, \quad \mathcal{S}' = \mathcal{D}(\mathcal{C}_{\mathcal{S}}) \quad (5.13)$$

we obtain a non-degenerate BTC* $\mathcal{C}' \rtimes \mathcal{S}'$. It would be interesting to understand the structure of the set of all such crossed products obtainable from a given \mathcal{C} .

5.3. The Case of Supergroups

Up to now we have assumed that all objects in \mathcal{S} are bosons, i.e., have twist equal to $+1$. Now we consider the general case, assuming that there is at least one fermionic degenerate sector. Clearly we may apply the construction as expounded so far to replace \mathcal{C} by $\mathcal{C}' = \mathcal{C} \rtimes \mathcal{D}_+$, where $\mathcal{D}_+ \subset \mathcal{D}$ is the category of bosonic degenerate objects. By the above it is clear that $\text{Gal}(\mathcal{C}' \rtimes \mathcal{D}_+) \cong \mathbb{Z}_2$, i.e., this BTC* has only one degenerate sector γ , which satisfies $\gamma^2 \cong 1$ and $\varepsilon(\gamma, \gamma) = -\text{id}_{\gamma^2}$.

LEMMA 5.4. *A fermionic degenerate object γ of dimension one does not have fixpoints, i.e., there is no irreducible $\rho \in \mathcal{C}$ such that $\gamma\rho \cong \rho$.*

Proof. Assume ρ is irreducible such that $\gamma\rho \cong \rho$. Then $\omega(\rho) = \omega(\gamma\rho)$. On the other hand, in view of $\varepsilon_M(\gamma, \rho) = \text{id}_{\gamma\rho}$, (2.10) implies $\omega(\rho) = \omega(\gamma\rho) \omega(\gamma)$. Since $|\omega(\rho)| = 1$ this is possible only if $\omega(\gamma) = 1$. ■

Thus $\text{Obj } \mathcal{C}'$ decomposes into orbits of length two under the action of γ by multiplication. Assuming naively that as in the bosonic case there is a similar cross product construction, which we call $\mathcal{C}' \rtimes \gamma$, we expect that the irreducible objects in \mathcal{C}' remain irreducible in $\mathcal{C}' \rtimes \gamma$. The only effect of the cross product construction should be pairwise identifying the objects ρ and $\gamma\rho$ for all ρ . The question is whether $\mathcal{C}' \rtimes \gamma$ exists as a BTC*. Unfortunately, this is impossible, since ρ and $\gamma\rho$ are equivalent in the would-be BTC* $\mathcal{C}' \rtimes \gamma$, but they have different twist.

This does, of course, not exclude the possibility that there is a full subcategory which contains precisely one object from each orbit $\{\rho, \gamma\rho\}$. But we do not have a criterion which would guarantee this.

6. CONCLUSIONS AND OUTLOOK

If symmetric tensor categories are considered as an extreme species of braided tensor categories then non-degenerate categories are the opposite extreme and the construction of the modular closure $\overline{\mathcal{C}}$ amounts to dividing out the symmetric part. Thus $\overline{\mathcal{C}}$ should be considered as the 1-dimensional analogue (in the sense of higher category theory) of the quotient group $G/Z(G)$, which for nice G (e.g., semisimple) has trivial center. The significance of our results lies in showing that every braided TC* (braided tensor category plus some additional structure) can be faithfully embedded into a braided tensor category which is non-degenerate. In this way we obtain a non-trivial category whenever the original one is not symmetric. In particular we obtain a unitary (in the sense of [29]) modular category whenever $\overline{\mathcal{C}} = \mathcal{C} \rtimes \mathcal{D}$ is rational. Since modular categories are instrumental in the construction of 3-manifold invariants [29] our construction has obvious applications to topology.

Our strategy for removing the degeneracy was to add morphisms to the category \mathcal{C} and to close the category $\mathcal{C} \rtimes_0 \mathcal{S}$ thus obtained w.r.t. subobjects. This is precisely the approach conjectured to work in [30, p. 460],

... it seems likely that one could get more modular categories by adding additional morphisms to the categories which are constructed in this paper...

These authors did not, however, indicate a general procedure. Comparison of our construction in Section 3 with [21] reveals that we have done little more than to translate the formulae *derived* in the QFT

framework [24, 21] into a more abstract setting and re-prove facts like associativity which are obvious in the QFT case. The considerations of Section 4, however, have little in common with those [21] in the QFT setting.

Concerning the special case of Subsection 5.1 where all irreducible degenerate objects have dimension one we cite [18, p. 359],

... In case \mathcal{J}_0 is a subgroup of invertibles $\{\sigma\}$ we have for the natural action of its elements on $k^{\mathcal{J}}$ that $\mathcal{S}\sigma = \mathcal{S}$. Hence \mathcal{S} and \mathcal{T} can be defined on the orbit space $\text{im}(\sum_{\sigma \in \mathcal{J}_0} \sigma)$, where we can hope for the modularity condition to hold.

Also this conjecture has been proved above, but as we have seen the decomposition into irreducibles of the objects in $\mathcal{C} \rtimes \mathcal{S}$ is not quite trivial, since it may be complicated by (i) the existence of the stabilizers K_ρ and by (ii) non-trivial 2-cocycles which lead to multiplicities $N_\rho > 1$, cf. also [9].

We have formulated our results in terms of C^* -tensor categories since they are the natural language for investigations on operator algebras and quantum field theories. But it should be clear—as already pointed out—that the C^* -structure does not play a crucial role. Replacing the DR duality theorem by the one of Deligne [5] one can formulate versions of our construction for braided tensor categories which are enriched over Vect_k for an arbitrary field k of characteristic zero. Also the strictness of the tensor categories assumed in this paper is not crucial. But note that Deligne has to assume integrality of dimensions in the symmetric category, whereas in the framework of C^* -categories this is automatic [6, Corollary 2.15] as a consequence of positivity.

We close by listing some questions which were not treated in this work and directions for further investigations:

1. Find a universal property which characterizes the modular closure $\overline{\overline{\mathcal{C}}}$ up to equivalence.

2. Let \mathcal{C} be a BTC^* , acted upon by a compact group G . Under which condition is there a subcategory $\mathcal{S} \subset \mathcal{D}(C^G)$ with $\text{Gal}(\mathcal{S}) \cong G$ such that $\mathcal{C} \simeq \mathcal{C}^G \rtimes \mathcal{S}$?

3. Clarify the decomposition of an irreducible $\rho \in \mathcal{C}$ into subobjects in $\mathcal{C} \rtimes \mathcal{S}$, extending the considerations in Subsection 5.1 to the non-abelian case. This looks difficult since not even the results of Subsection 5.1 for the abelian case are very explicit. We indicate a generalization of the considerations given above which, however, is not quite sufficient. Assume $\rho \in \mathcal{C}$ irreducible is such that $\gamma\rho \cong d_\gamma\rho$ whenever $\gamma \in \mathcal{S}$ is irreducible and $\text{Hom}(\gamma\rho, \rho) \neq \{0\}$. (This clearly includes the case of G being abelian.) Then the set $\{\gamma \in \mathcal{S} \mid \gamma\rho \cong d_\gamma\rho\}$ is closed under multiplication and gives rise to a full subcategory \mathcal{S}_ρ of the $\text{STC}^*\mathcal{S}$, which is the representation category of

a quotient G_ρ of G . Clearly, the action of G on $\text{Hom}_{\mathcal{C} \rtimes \mathcal{S}}(\rho, \rho)$ factors through G_ρ . This action of G_ρ has full multiplicity in the sense that the spectral subspace corresponding to any irreducible representation π_k has dimension d_k^2 . Then the considerations of [31, II] apply and we know that $\text{Hom}_{\mathcal{C} \rtimes \mathcal{S}}(\rho, \rho) \cong \pi_\omega(\widehat{G}_\rho)$ where ω is a 2-cocycle on \widehat{G}_ρ and the isomorphism intertwines the actions of G_ρ . See [31, II] for the terminology. This case seems, however, too special to deserve further analysis.

4. Given a rational BTC* \mathcal{C} find a direct construction of the 3-manifold invariant arising from the modular closure $\overline{\mathcal{C}}$, bypassing the construction of the latter.

5. There is an obvious connection between the crossed product $\mathcal{C} \rtimes \mathcal{S}$ and the “orbifold constructions in subfactors” [8, 33] which deserves to be worked out.

6. Generalize everything in this paper to the non-connected case where $\text{Hom}(\iota, \iota) \neq \mathbb{C} \text{id}_\iota$ and the compact (super)groups are replaced by compact (super)groupoids [2]. The resulting Galois theory should resemble the Galois theory for commutative rings instead of the one for fields.

7. Since Janelidze’s general Galois theory for categories [13] was modeled on the Galois theory for commutative rings as expounded by Magid, it should be possible to show that with the proper identifications our Galois correspondence fits into Janelidze’s formalism, also after extension to the non-connected case.

ACKNOWLEDGMENTS

This paper would not have been written without K.-H. Rehren’s works [23, 24] and his proposal to pursue the line of research which led to [21]. I am grateful to J. E. Roberts and R. Longo for many useful discussions and to L. Tuset for a discussion on Proposition 2.4. I thank D. E. Evans for the opportunity to present this work in the Wales Video Seminar at an early stage and R. Brown and T. Porter for interest and suggestions provided on this occasion. The tangle diagrams were generated using the macro package `tangle-s.sty` written by Yu. Bernalov and V. Lyubashenko.

Note added in proof. After this paper was completed I received the preprint *Catégories prémodulaires, modularisations et invariants de variétés de dimension 3* by A. Bruguières, which was finished several months earlier. In this paper a construction is given which is equivalent to our definition of $\mathcal{C} \rtimes \mathcal{S}$ if \mathcal{S} is rational, i.e., $\text{Gal}(\mathcal{S})$ is finite, and $\mathcal{S} \subset \mathcal{D}$. Bruguières does not consider the cases where $\mathcal{S} \not\subset \mathcal{D}$ or $|\text{Gal}(\mathcal{S})| = \infty$, nor does he obtain the results of Proposition 4.2. and the Galois correspondence. On the other hand his construction is more elegant and canonical—yet less elementary—in that it neither uses a section $\{\gamma_k, k \in \widehat{G}\}$ nor bases in the intertwiner spaces, and he solves the problems 1 and 4 listed above. Bruguières’ work relies on Deligne’s characterization [5] of representation categories, which confirms our claim that the latter can be used instead of the one by Doplicher and Roberts. Of course, this entails that the integrality assumption on the dimension appears in all statements. I thank Dr. Bruguières for correspondence on our—otherwise independent—works.

REFERENCES

1. S. Albeverio and R. Høegh-Krohn, Ergodic actions by compact groups on C^* -algebras, *Math. Z.* **174** (1980), 1–17.
2. J. C. Baez, Higher dimensional algebra. II. 2-Hilbert spaces, *Adv. Math.* **127** (1997), 125–189.
3. C. W. Curtis and I. Reiner, “Representation Theory of Finite Groups and Associative Algebras,” Wiley, New York, 1962.
4. P. Deligne and J. S. Milne, Tannakian categories, in “Hodge Cycles, Motives, and Shimura Varieties,” Lecture Notes in Math., Vol. 900, pp. 101–228, Springer-Verlag, New York/Berlin, 1982.
5. P. Deligne, Catégories Tannakiennes, in “Grothendieck Festschrift,” Vol. 2, pp. 111–193, Birkhäuser, Basel, 1991.
6. S. Doplicher and J. E. Roberts, A new duality theory for compact groups, *Invent. Math.* **98** (1989), 157–218.
7. S. Doplicher and J. E. Roberts, Why there is a field algebra with a compact gauge group describing the superselection structure in particle physics, *Comm. Math. Phys.* **131** (1990), 51–107.
8. D. E. Evans and Y. Kawahigashi, Orbifold subfactors from Hecke algebras, I, *Comm. Math. Phys.* **165** (1994), 445–484; II, **196** (1998), 331–361.
9. J. Fuchs, A. N. Schellekens, and C. Schweigert, A matrix S for all simple current extensions, *Nucl. Phys. B* **473** (1996), 323–366.
10. P. Ghez, R. Lima, and J. E. Roberts, W^* -Categories, *Pacific J. Math.* **120** (1985), 79–109.
11. A. Grothendieck, “Revêtements étales et groupe fondamental (SGA 1),” Lecture Notes in Math., Vol. 224, Springer-Verlag, New York/Berlin, 1972.
12. R. Høegh-Krohn, M. B. Landstad, and E. Størmer, Compact ergodic groups of automorphisms, *Ann. Math.* **114** (1981), 75–86.
13. G. Janelidze, The fundamental theorem of Galois theory, *Math. USSR Sb.* **64** (1989), 359–374; Pure Galois theory in categories, *J. Algebra* **132** (1990), 210–286.
14. A. Joyal and R. Street, Braided tensor categories, *Adv. Math.* **102** (1993), 20–78.
15. G. Karpilovsky, “Projective Representations of Finite Groups,” Dekker, New York, 1985.
16. D. Kastler (Ed.), “The Algebraic Theory of Superselection Sectors: Introduction and Recent Results,” World Scientific, Singapore, 1990.
17. D. Kastler, M. Mebkhout, and K.-H. Rehren, Introduction to the algebraic theory of superselection sectors (space-time dimension = 2—strictly localized morphisms), in “The Algebraic Theory of Superselection Sectors: Introductions and Recent Results,” World Scientific, Singapore, 1990.
18. T. Kerler and J. E. Roberts, Mapping class group actions on quantum doubles, *Comm. Math. Phys.* **168** (1995), 353–388.
19. R. Longo and J. E. Roberts, A theory of dimension, *K-Theory* **11** (1997), 103–159.
20. S. Mac Lane, “Categories for the Working Mathematician,” 2nd ed., Springer-Verlag, New York/Berlin, 1998.
21. M. Müger, On charged fields with group symmetry and degeneracies of Verlinde’s matrix S , *Ann. Inst. H. Poincaré Phys. Théor.* **71** (1999), 359–394.
22. M. Müger, On Galois extension of braided tensor categories, mapping class group representations and quantum field theory, in preparation.
23. K.-H. Rehren, Braid group statistics and their superselection rules, in “The Algebraic Theory of Superselection Sectors: Introduction and Recent Results,” World Scientific, Singapore, 1990.
24. K.-H. Rehren, Markov traes as characters for local algebras, *Nucl. Phys. B(Proc. Suppl.)* **18** (1990), 259–268.
25. J. E. Roberts, The reconstruction problem, unpublished manuscript, 1971.

26. J. E. Roberts, Lectures on algebraic quantum field theory, in "The Algebraic Theory of Superselection Sectors: Introduction and Recent Results," World Scientific, Singapore, 1990.
27. J. E. Roberts and L. Tuset, On the equality of q -dimension and intrinsic dimension, *J. Pure Appl. Alg.*, in press.
28. N. Saaveda Rivano, "Catégories Tannakiennes," Lecture Notes in Math., Vol. 265, Springer-Verlag, New York/Berlin, 1972.
29. V. G. Turaev, "Quantum Invariants of Knots and 3-Manifolds," de Gruyter, Berlin/New York, 1994.
30. V. G. Turaev and H. Wenzl, Semisimple and modular categories from link invariants, *Math. Ann.* **309** (1997), 411–461.
31. A. Wassermann, Ergodic actions of compact groups on operator algebras, I, *Ann. Math.* **130** (1989), 411–319; II, *Canad. J. Math.* **40** (1988), 1482–1527.
32. H. Wenzl, C^* -Tensor categories from quantum groups, *J. Amer. Math. Soc.* **11** (1998), 261–282.
33. F. Xu, Orbifold construction in subfactors, *Comm. Math. Phys.* **166** (1994), 237–253.
34. S. Yamagami, Tensor categories for operator algebraists, unpublished notes, 1998.