

Differences in specificity for the interactions of stefins A, B and D with cysteine proteinases

Brigita Lenarčič*, Igor Križaj, Petra Žunec, Vito Turk

Department of Biochemistry and Molecular Biology, J. Stefan Institute, Jamova 39, 1000 Ljubljana, Slovenia

Received 10 July 1996; revised version received 29 August 1996

Abstract Four different stefin-type cysteine proteinase inhibitors have been isolated from porcine thymus and skin. Amino acid sequence determination revealed the presence of stefin A and stefin B type inhibitors and two new inhibitors, designated as porcine stefin D1 and stefin D2. Stefin D1 was identified as PLCPI, an inhibitor recently characterized from porcine polymorphonuclear leukocytes [Lenarčič et al. (1993) FEBS Lett. 336, 289–292]. Stefin A is composed of 101 amino acids and has an M_r of 11 391 while stefin B contains 98 amino acids, has an M_r of 11 174 and is N-terminally blocked. All inhibitors were found to be fast-acting inhibitors of papain, cathepsin L and cathepsin S ($K_i = 0.009–0.161$ nM). Stefins A and B also bind tightly and rapidly to cathepsin H ($K_i = 0.027$ and 0.069 nM, respectively), while stefins D1 and D2 have been shown to be very poor inhibitors of cathepsin H ($K_i = 102–150$ nM). The decreased affinity of these inhibitors toward cathepsin B ($K_i = 2–1700$ nM) was shown to be mainly due to the low second order association rate constants. The presence of a highly negatively charged N-terminus on stefin D1 constitutes a likely structural determinant of inhibitor specificity.

Key words: Cysteine proteinase inhibitor; Papain; Cathepsin; Amino acid sequence; Kinetics

1. Introduction

Stefins comprise one of the protein families of cysteine proteinase inhibitors which belong to the cystatin superfamily [1,2]. They are low molecular weight (M_r about 11 000), single-chain, acidic proteins with no disulphide bonds or carbohydrates [1,3]. Stefins A and B have been identified in human tissues [4–8] and their analogues have been found in rat [9,10], bovine [11–13] and porcine tissues [14]. The stefin B inhibitor may play a role in the regulation of proteolysis in the cytosol of different tissues, while stefin A probably controls the activities of cysteine proteinases predominantly in the skin [1]. The inhibition of mammalian cysteine proteinases, cathepsin B, H, L and S, and some plant enzymes, such as papain and actinidin, occurs via the formation of tight and reversible equimolar complexes between inhibitors and their target enzymes [1]. Fundamental information about the nature of the binding has been provided from the crystal structure of chicken cys-

tin [15,16] and of a complex of stefin B with carboxymethyl-papain [17]. The reactive site of the inhibitor comprises of two hairpin loops and the N-terminal part of the inhibitor forms a hydrophobic wedge-shaped edge, which is highly complementary to the active site of the papain. The crystal structure of cathepsin B differs from that of papain in having an extra loop of about 20 residues that partially occludes the active site cleft, thus lowering the affinity of binding the cystatin-like protein inhibitors to cathepsin B [18] and explaining its dipeptidyl carboxypeptidase activity.

In this paper we present the purification and characterization from porcine tissue of stefins A and B and two new stefin-type inhibitors, designated stefins D1 and D2. The complete amino acid sequences of stefins A, B and D1 were determined and compared with other known stefin-type sequences. In addition, their kinetics of interaction with papain-like cysteine proteinases were determined.

2. Materials and methods

2.1. Enzymes

Papain (EC 3.4.22.2; 2× crystallized) was from Sigma; human cathepsins B (EC 3.4.22.1) and L (EC 3.4.22.15) [19,20] and bovine cathepsins H (EC 3.4.22.16) and S (EC 3.4.22.27) [21,22] were purified as described. Glycyl endopeptidase (EC 3.4.22.25) was a gift from Dr. Alan J. Barrett (Strangeways Research Laboratories, Cambridge). *Staphylococcus aureus* strain V-8 proteinase (EC 3.4.21.19) was obtained from Miles; α -chymotrypsin (EC 3.4.21.1; 3× crystallized) and clostripain (EC 3.4.22.8) were from Sigma. β -Trypsin (EC 3.4.21.1) was prepared according to [23].

2.2. Purification procedure

Inhibitors were purified from porcine thymus using a procedure slightly modified from that previously described for the isolation of human stefins A and B [8]. Affinity chromatography on Cm-papain Sepharose was used as the first purification step, followed by gel chromatography on Sephadex G-50 where two inhibitory peaks with M_r of about 25 000 and 12 000 were obtained. Both peaks were concentrated by ultrafiltration, dialysed against 0.01 M Tris buffer, pH 7.4, and further purified on a DEAE-Sephacel column (2×26 cm) equilibrated with the same buffer. Bound proteins were eluted with a linear gradient of NaCl (0–0.25 M) in the starting buffer. Stefin B was eluted in the dimer form with an M_r of about 25 000 while the proteins with lower M_r were eluted in two major inhibitory peaks identified by sequence as stefins D1 and D2.

The same purification scheme was used for the isolation of the inhibitors from porcine skin. Only one inhibitory peak with an M_r of about 12 000, identified by sequence as stefin A, was obtained after gel chromatography and ion-exchange chromatography on DEAE-Sephacel using a gradient of NaCl (0–0.3 M) in 0.01 M Tris buffer, pH 7.4.

Analytical isoelectric focusing of the inhibitors was performed on a Phastsystem apparatus (Pharmacia, Sweden).

2.3. Sequence determination and amino acid analysis

Stefin B was reduced with β -mercaptoethanol at 37°C, overnight. The molecule was *S*-pyridylethylated as described [24]. Pyridylethylated stefin B (PE-stefin B) was dissolved in 80% (v/v) HCOOH and a

*Corresponding author. Fax: +386 61 27 35 94.
E-mail: brigita.lenaric@ijs.si

Abbreviations: -AMC, 4-methyl-7-coumarylamide; Bz-, benzoyl; Cm-, carboxymethyl-; CNBr, cyanogen bromide; Ep-475, L-3-carboxy-trans-2,3-epoxypropylleucylamido(3-guanidino)butane; HPLC, high-performance liquid chromatography; PAGE, polyacrylamide gel electrophoresis; PITC, phenylisothiocyanate; PLCPI, pig leukocyte cysteine proteinase inhibitor; PTH, phenylthiohydantoin; Z-, benzyloxycarbonyl-

50-fold molar excess of CNBr over methionine residues was added. After 61 h incubation at room temperature in the dark the reaction was quenched with the addition of 5 vols. of twice-distilled water and the protein freeze-dried. Native stefins D1 and D2 were cleaved with CNBr in a similar manner.

Native stefin B was hydrolysed by glycyl endopeptidase as described [25]. The G2-peptide and stefins A and B were maleylated and demaleylated according to [26]. G2-peptide was also subjected to mild acid hydrolysis in 80% (v/v) HCOOH at 37°C for 68 h. The reaction was stopped by dilution of the reaction mixture with twice-distilled water and freeze-drying.

Native stefins A and B were incubated with β -trypsin in 0.1 M *N*-methylmorpholine/acetate buffer, pH 8.11, at 37°C for 3 h. The enzyme was added in two portions to a final concentration of 4% (w/w).

Maleylated stefin A and maleylated G2-peptide were fragmented using 2–4% (w/w) *S. aureus* V-8 proteinase in 0.1 M Na phosphate, pH 7.8, at 37°C for 18–24 h. Reactions were stopped by acidification with trifluoroacetic acid. E8-peptide, from *S. aureus* V-8 proteinase fragmentation of stefin A, was further fragmented by α -chymotrypsin. The same buffer as for tryptic digestion was used. The incubation time was 2 h and the concentration of proteinase 4% (w/w).

Peptide mixtures were separated by HPLC (Milton Roy, USA) using a reverse-phase, ChromSep C8, Vydac C18 or Aquapore RP-300 column equilibrated with 0.1% (v/v) trifluoroacetic acid in water. Elution was performed with various linear gradients of 80% (v/v) acetonitrile containing 0.1% (v/v) trifluoroacetic acid. Absorbance was monitored at 215 nm.

Protein samples were hydrolysed in 6.0 M HCl at 110°C for 24 h. Peptide hydrolysates were analysed using an amino acid analyser Applied Biosystems 421A (USA) with pre-column PITC derivatization.

An Applied Biosystems (USA) liquid-pulse sequencer 475A, connected on-line to a PTH analyser 120A from the same manufacturer, was used for automated amino acid sequence analyses.

Molecular mass analysis of N-terminally blocked G1-peptide was accomplished on an Autospec Q mass spectrometer (VG-Analytical, UK), using the fast atom bombardment ionization method. Glycerol was used as a matrix.

2.4. Kinetics of inhibition of cysteine proteinases

For routine assays, the papain inhibitory activity of the samples was determined using Bz-DL-Arg-2 naphthylamide as substrate [27]. Active site titrations of papain, cathepsins B, L and S were performed using cysteine proteinase inhibitor Ep-475, while cathepsin H was active site titrated with stefin B, whose molarity was previously determined with active site titrated papain [12].

In all kinetic experiments, papain, cathepsins B, and S were assayed using 0.1 M phosphate buffer, pH 6.0, containing 2 mM dithiothreitol and 1.5 mM EDTA. For cathepsin H, 0.1 M phosphate buffer, pH 7.0, containing 2 mM dithiothreitol and 1.5 mM EDTA was used, while cathepsin L was assayed in 0.1 M acetate buffer, pH 5.5, containing 1.5 mM EDTA and 2 mM dithiothreitol. Continuous rate assays were used for kinetic analysis of the interactions of papain, cathepsins B, H, L and S with stefins A, B and D2. Variable concentrations of inhibitors and substrates (5 μ M Z-Phe-Arg-AMC for papain, 10 μ M Z-Phe-Arg-AMC for cathepsins B and L, 20 μ M Z-Phe-Arg-AMC for cathepsin S and 10 μ M Arg-AMC for cathepsin H) were dissolved in 1.97 ml of the appropriate buffer. The reaction was started by the addition of 20 μ l of activated papain (380 pM final concentration), cathepsin B (130 pM final concentration), cathepsin H (300 pM final concentration) or cathepsin S (200 pM final concentration), respectively. All experiments were performed under pseudo-first order conditions, i.e. at a molar ratio of the inhibitors to enzymes of 10:1. The progress curves were monitored at excitation and emission wavelengths of 370 and 460 nm, respectively, using a Perkin Elmer LS-3 spectrofluorimeter. Data were analysed by non-linear regression analysis according to [28].

The equilibrium dissociation constants for the interaction between stefin D2 with cathepsins B and H were determined using a stopped assay. Activated cathepsin B (130 nM final concentration) and cathepsin H (25 nM final concentration) were incubated for 20 min at 25°C with inhibitors at various concentrations (50–750 nM final concentrations) in appropriate buffer. Residual activities of cathepsins B and H were determined under the same conditions as described previously [27] using Bz-DL-Arg-2 naphthylamide and Arg-2 naphthylamide, respectively, as substrates.

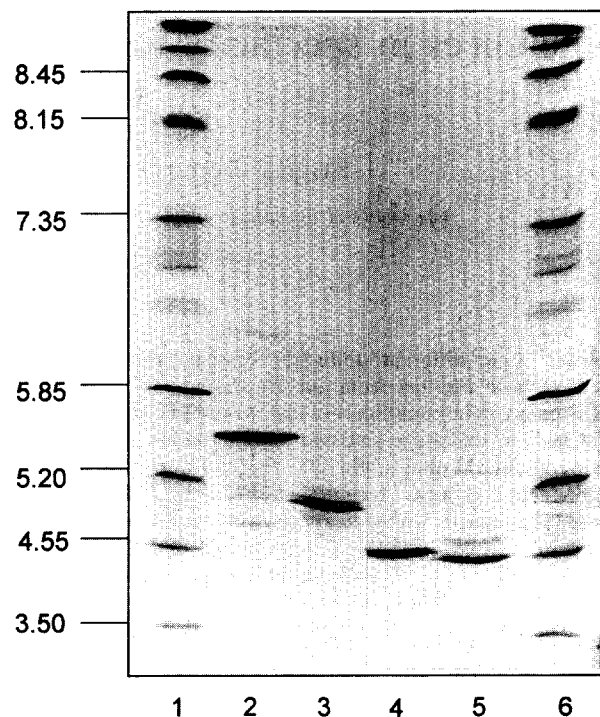

Fig. 1. Isoelectric focusing of the purified inhibitors. Lanes: 1,6, standards; 2, stefin A; 3, stefin B; 4, stefin D1; 5, stefin D2.

3. Results

3.1. Purification of the inhibitors

We isolated from porcine thymus and skin four different cysteine proteinase inhibitors. This purification resulted in final yields of 1.9 mg of stefin D1, 2.1 mg of stefin D2 and 2.5 mg of stefin B from 2 kg of porcine thymus and 1.8 mg of stefin A from 1.5 kg of porcine skin.

Analytical isoelectric focusing showed that all the inhibitors are acidic proteins, each exhibiting a single band (Fig. 1) (the second band in stefin B appears on storage). The following pI values were determined: 4.6 for stefin D1, 4.5 for stefin D2, 5.5 for stefin A and 5.0 for stefin B.

3.2. Sequence determination of stefin A

Native stefin A was cleaved with trypsin, and T-peptides were isolated and sequenced (Fig. 2a). The T12–13 peptide represented the C-terminus of the molecule, as Phe is not a cleavage point for β -trypsin. The second set of peptides was prepared using *S. aureus* V-8 proteinase which cleaves after Glu. Before digestion, stefin A was maleylated in order to destroy the strong tertiary structure of the inhibitor and expose the cleavage sites. V-peptides resulted and their sequence analysis provided most of the overlaps (Fig. 2a). V7–8 peptide was very hydrophobic and only scarcely soluble. It was purified by washing the precipitate. The C-terminal sequence was confirmed by V10-peptide which ended with Phe and not with Glu. The last uncertainties in the structure were resolved by subfragmentation of V7–8 peptide with α -chymotrypsin and analysis of the resulting CT-peptides. Porcine stefin A consists of 101 amino acid residues. Its M_r is 11391.

3.3. Sequence determination of stefin B

The N-terminal sequence analysis of the native molecule of

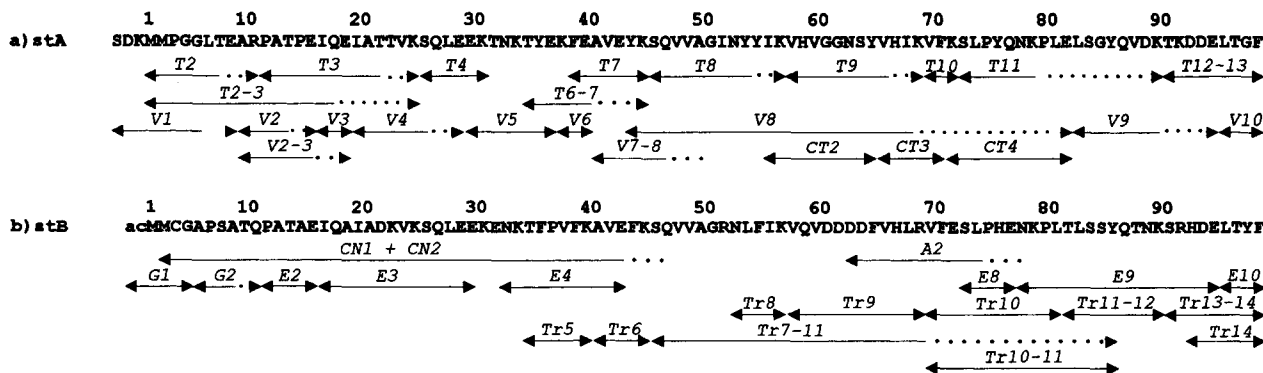

Fig. 2. Amino acid sequences and strategies of the sequence determination of porcine stefin A (a) and stefin B (b). T- and Tr-peptides were obtained from trypsin cleavage, V- and E-peptides from *S. aureus* V-8 proteinase hydrolysis, CT-peptides from chymotrypsin digestion, CN-peptides were derived from CNBr cleavage, G-peptides from glycol endopeptidase hydrolysis, and A-peptides after acid hydrolysis.

stefin B failed, suggesting that the molecule is N-terminally blocked. However, after the reaction of PE-stefin B with CNBr the sequence analysis was no longer prevented although the M_r of the protein remained virtually unchanged. In the first sequencing cycle, in addition to PE-Cys, traces of Met were also identified, indicating the existence of two consecutive Met residues at the N-terminus of the peptide (peptide CN1+CN2 in Fig. 2b). As Gly was found near the N-terminus of stefin B, Gly-C endoproteinase was used for the fragmentation of native stefin B in order to generate the N-terminal peptide (G1). Besides G1-peptide only one more peptide (G2) resulted from this reaction, representing the rest of the molecule. Mass spectrometry as well as amino acid analysis of G1-peptide revealed that its N-terminal amino acid residue was N-acetylated. G2-peptide was exposed to mild acid hydrolysis and a low-yield cleavage of Asp⁶²-Thr⁶³ was detected (A2-peptide in Fig. 2b). The rest of G2-peptide was maleylated to achieve maximal unfolding and subcleaved with *S. aureus* V-8 proteinase. The peptide mixture was demaleylated and separated by HPLC. The peptides which were sequenced (E-peptides) are shown in Fig. 2. Peptide E10 represented the C-terminus of the molecule as it ended with Phe which is not a cleavage site of *S. aureus* V-8 proteinase. Tryptic cleavage of native stefin B provided peptides which were necessary to solve the rest of the inhibitor structure (Tr-peptides in Fig. 2b). Additional confirmation of the C-terminus was given by peptides Tr14 and Tr13-14. Porcine stefin B consists of 98 amino acid residues. Its M_r is 11 174.

3.4. Sequencing of stefins D1 and D2

By sequencing of peptides obtained after CNBr cleavage and by amino acid analysis, we have shown that stefin D1 is identical to PLCPI from porcine polymorphonuclear leukocytes [14]. When N-terminal sequence analysis of native stefin D2 was attempted no signal was obtained, indicating that its N-terminus is blocked. Following CNBr cleavage, however, the sequence of 36 amino acids, shown in Fig. 3, was established.

3.5. Amino acid sequence comparison

In Fig. 3 the amino acid sequences of stefins D1, D2, A and B are aligned with those of other mammalian stefin-type inhibitors. Pairwise comparisons for sequence identity between the members of the stefin family (Fig. 4) show 54-74% identity between members of the stefin A group and 71-85% between members of the stefin B group. Sequence comparison of the N-terminal fragment of stefin D2 with other inhibitors showed an extremely high proportion of identical residues with porcine stefin D1 (90% in 36 residues, Fig. 3). The sequence identity of stefin D1 with members of the stefin A and B type inhibitors is 51-79 and 54-57%, respectively.

3.6. Kinetics of inhibition of the cysteine proteinases

The rate constants of complex formation of papain, cathepsin B, cathepsin H, cathepsins L and cathepsin S with stefin A, stefin B and stefin D2 were determined in pre-steady state experiments where the enzyme was added to a mixture of

	1	10	20	30	40	50	60	70	80	90
pD1	MESEEMLAGGLTEPRPATPEIQEIAITTVKSQLLEEKTNKTYEKFEAVEYKSQLVAGINYYIKVHVGNSYVHIKVFQSLPHQEDPLKLIQYQVDRKDDDELDTGF									
pD2DT.....K.D									
pA	SDKMPGGLTEARPATPEIQEIAITTVKSQLLEEKTNKTYEKFEAVEYKSQLVAGINYYIKVHVGNSYVHIKVFKSLPYQNKPLELSGYQVDRKDDDELDTGF									
hA	.I...S.K.....VDR.P.....G.L...Q..T...T.....RA.D.K.M.L.....G..ED.V.T.....N.....									
ra	MDPGTTGIV..VS..K.....V.DK..R.....K...KV.....QILFM..D..NGRFL.M..LRG.SGDD-D.K.LD..TN...N...D..									
ba	.I.....K...I.....NM.P.....E.T.I.....IQT.D.R.I.....Q.SHS.I.T.....A..									
pB	MMCGAPSATQPATAEIQAIADKVKSQLLEEKNTFFVFKAVEFKSQLVAGRNLFIKVQVDDDDFVHLRVFESLPHENKPLTLSSYQTNKSRHDELTYF									
hBT.H...Q.R.....K.....S.....T.Y...H.G.E.....Q.....N.....AK.....									
rβM..T.T.E.....A.QK.D...IS.RR...T.F...D.GEEKC.....EP.....D.EK.....									
bBT.....K.....L...L...K.Y.....E...I...E.....VA.T.....G.....									
bC	MWGNLGGFSDTQDATAEIQAIADKVKSQLLEEKNTFFVFKAVEFKSQLVAGRNLYIKVQVDEDDFVHLRVFESLPHENKPVALTSYQTNKVRHDELTYF									

Fig. 3. Alignment of the amino acid sequences of porcine stefins with those of other stefins. pD, porcine stefin D (pD1 is identical to PLCPI [14]); pA, porcine stefin A; hA, human stefin A; ra, rat cystatin α; ba, bovine stefin A [13]; pB, porcine stefin B; hB, human stefin B; rβ, rat cystatin β; bB, bovine stefin B [11]; bC, bovine stefin C [12]. Other references have been listed by Turk and Bode [3]. Dots denote the residues identical to those above (porcine stefins D1, A and B, respectively).

	porc stD1	porc stA	hum stA	rat cys α	bov stA	porc stB	hum stB	rat cy β	bov stB	bov stC
porc stD1	-	79	70	51	71	55	57	57	54	52
porc stA	-	-	74	56	57	60	60	56	57	53
hum stA	-	-	-	57	73	53	53	53	48	47
rat cys α	-	-	-	-	54	51	48	47	47	44
bov stA	-	-	-	-	-	50	47	46	48	46
porc stB	-	-	-	-	-	-	84	75	85	79
hum stB	-	-	-	-	-	-	-	78	78	72
rat cy β	-	-	-	-	-	-	-	-	71	65
bov stB	-	-	-	-	-	-	-	-	-	84
bov stC	-	-	-	-	-	-	-	-	-	-

Fig. 4. Matrix of pair-wise sequence comparisons for amino acid sequences of the members of the stefin family. The percent of identity was calculated for all pairs of mammalian stefins from the number of matched amino acids. porc stD1, porcine stefin which is identical to PLCPI [14]; porc stA, porcine stefin A; hum stA, human stefin A; rat cys α , rat cystatin α ; bov stA, bovine stefin A; porc stB, porcine stefin B; hum stB, human stefin B; rat cy β , rat cystatin β ; bov stB, bovine stefin B.

the inhibitor and substrate. Release of the product was continuously recorded and typical biphasic progress curves were observed. Measurements were analysed by fitting the product release data to the integrated rate equation [28]. Linear dependence of the pseudo first-order rate constant on inhibitor concentration was observed for all enzyme-inhibitor pairs investigated. k_{ass} values were calculated from the slope of the dependence of the pseudo-first-order rate constant on inhibition concentration, using K_m values of 2 μM for cathepsin L [29], 11 μM for cathepsin S [30], 65 μM for papain [31] and 250 μM for cathepsin B [32] (Z-Phe-Arg-AMC) and 150 μM for cathepsin H [27] (Arg-AMC). k_{diss} values were calculated for each inhibitor concentration. K_i values were calculated from k_{ass} and k_{diss} .

The higher K_i values for the interaction of cathepsins B and H with stefin D2 had to be determined by measuring the residual enzyme activities. From the plot of residual enzyme activity versus concentration of the inhibitor, the K_i values were calculated using the modified Ackermann-Potter equation [33].

The kinetic constants, k_{ass} , k_{diss} and K_i are listed in Table 1. It is evident that all inhibitors are fast-acting and tight-binding inhibitors of papain, cathepsin L and cathepsin S. The markedly decreased affinities of stefin A and stefin B for cathepsin B are primarily due to decreased values of k_{ass} . The values of K_i for stefins D1 and D2 are so high that values of k_{ass} could not be determined. The k_{ass} is 40-fold lower for stefin B than k_{ass} for stefin A, whose k_{ass} is still more than 10-fold lower than the values for other cathepsins or for papain. Decreased affinity for cathepsin H was observed only with stefins D1 and D2, whereas stefins A and B bind rapidly and tightly to cathepsin H with K_i values more than 3 orders of magnitude lower.

4. Discussion

Eight members of the stefin family [2] of mammalian cysteine proteinase inhibitors have been characterized on the protein level: human stefin A [6], human stefin B [8], rat cystatin α [34], rat cystatin β [35], bovine stefin A [13], bovine stefin B [11], bovine stefin C [12] and PLCPI, a stefin-type inhibitor isolated from porcine polymorphonuclear leukocytes [14]. All the inhibitors, except PLCPI, are members of stefin A, B or C types. In this work we have isolated from porcine thymus stefin B and two new, very closely related stefins, designated as stefins D1 and D2. Stefin D1 has been identified as the previously characterized PLCPI [14], while stefin A or C type inhibitors were not detected in thymus. We isolated stefin A from porcine skin consistent with previous findings

Table 1
Kinetic and equilibrium data for the interaction between porcine cysteine proteinase inhibitors and papain and cathepsins B, H, L and S

Enzyme	Inhibitor	k_{ass} ($\text{M}^{-1} \text{s}^{-1}$) ($\times 10^{-6}$)	k_{diss} (s^{-1}) ($\times 10^4$)	K_i (nM)
Papain	stefin D1	1.00 \pm 0.31	1.90 \pm 0.39	0.190 \pm 0.097 ^a
	stefin D2	8.60 \pm 1.21	3.62 \pm 0.26	0.042 \pm 0.009
	stefin A	4.31 \pm 1.32	7.49 \pm 0.63	0.174 \pm 0.066
	stefin B	21.68 \pm 2.82	26.84 \pm 2.50	0.124 \pm 0.027
Cathepsin B	stefin D1	N.D.	N.D.	335 \pm 50 ^a
	stefin D2	N.D.	N.D.	195 \pm 80
	stefin A	0.159 \pm 0.018	3.17 \pm 0.32	2 \pm 0.42
	stefin B	0.004 \pm 0.0004	3.35 \pm 0.29	84 \pm 15
Cathepsin H	stefin D1	N.D.	N.D.	125 \pm 7 ^a
	stefin D2	N.D.	N.D.	102 \pm 4
	stefin A	5.04 \pm 0.80	3.50 \pm 0.05	0.069 \pm 0.012
	stefin B	0.70 \pm 0.05	0.19 \pm 0.01	0.027 \pm 0.003
Cathepsin L	stefin D1	5.50 \pm 0.65	3.70 \pm 1.64	0.067 \pm 0.036 ^a
	stefin D2	1.79 \pm 0.42	2.90 \pm 0.27	0.161 \pm 0.051
	stefin A	38.42 \pm 7.09	7.74 \pm 0.75	0.020 \pm 0.005
	stefin B	21.90 \pm 1.75	2.12 \pm 0.02	0.009 \pm 0.001
Cathepsin S	stefin D1	13.50 \pm 1.06	6.29 \pm 1.25	0.046 \pm 0.013 ^a
	stefin D2	11.15 \pm 1.04	4.16 \pm 0.56	0.037 \pm 0.008
	stefin A	6.83 \pm 0.38	3.61 \pm 0.13	0.053 \pm 0.004
	stefin B	8.28 \pm 1.90	7.45 \pm 0.80	0.090 \pm 0.029

The experimental conditions are described in Sections 2 and 3. N.D., not determined.

^a K_i values are from [14].

that human stefin A and rat cystatin α are present in high concentrations in various types of epithelial cells and polymorphonuclear granulocytes [1,4,6,10].

The acidic *pI* value is a characteristic feature of stefins [5–8,10–12]. Stefins B and D2 have blocked N-termini, while stefin D1 was found to have a partially open and stefin A a completely free N-terminus. A blocked N-terminus is another characteristic feature of most inhibitors from the stefin family [8,12,25,34–36].

Pairwise comparison of sequence identity between inhibitors (Fig. 3) shows that porcine stefin A fits into the stefin A group as well as stefin B does into the stefin B group. Additionally, porcine stefin B appeared in both dimeric and monomeric forms (data not shown), similar to rat [36], human [8] and bovine stefin B [11]. The sequence identity between stefin D1 and the stefin A or B types of inhibitors is around 68 and 56%, respectively. The sequence identity with bovine stefin C is lower (52%).

Several studies have been performed on the importance of certain individual amino acids present in the binding segments, especially of those in the first β -hairpin loop (central QVVAG region) and the N-terminal part. Various mutations in the QVVAG region did not alter dramatically the inhibitory capacity of stefins or cystatins [37–40]. In contrast, the length and structure of the N-terminal region, which binds with at least two residues to the S2 and S3 subsites of the enzyme [16], were found to be critical for the inhibitory activity of cystatins [41–45], whereas for the stefins the effect of truncation of the N-terminus was less important [46,47]. All mentioned studies were performed either on N-terminal truncated cystatins/stefins or on mutant forms of human cystatin C [44].

A more detailed sequence comparison of the interacting regions of all stefins showed that both hairpin loops are highly similar with minor, homologous substitutions in the second loop. However, the N-terminal region of stefin D1 differs markedly from those of stefins A and B in being slightly longer and especially in its highly negative potential with three out of the first five residues being Glu (Fig. 3). This could explain the differences observed in the kinetics of inhibition of cathepsins B and H by different stefins. Since stefins D1 and D2 exhibited similar kinetics of inhibition of all the enzymes and shared a high degree of sequence homology in the D2 fragment sequenced, it could be suggested that both stefins are highly homologous, including the N-terminus.

The presence of the 20 amino acid residue occluding loop which covers the active site of cathepsin B [18] explains why the interaction with inhibitors is much reduced in rate as compared with other cathepsins. The markedly decreased affinities of porcine stefins A and B for cathepsin B were almost exclusively due to a decreased association rate constant, as also shown for bovine stefin A [13] and truncated [42,45] or N-terminally mutated cystatins [44]. The affinities of porcine stefins D1 and D2 for cathepsin B were even much lower, which could be explained by the repulsion between the negatively charged N-terminus of the inhibitor and Glu-78 and Glu-245 of the enzyme in the putative binding site of the latter.

A similar explanation is probably valid for cathepsin H. Unfortunately, no crystal structure of cathepsin H is available, which makes such a conclusion speculative. Nevertheless, it was shown that the active site cleft of cathepsin H is

partially occupied by an octapeptide [48] that also interferes with the inhibitor binding. However, there are significant differences in the structure of cathepsin B and that of cathepsin H [18,48].

By contrast, similar kinetics of interaction between all stefins and cathepsins L and S and papain indicates that the negatively charged N-terminal extension of stefin D1 does not interfere with enzyme binding. In addition, these results indicate that these enzymes have similar structures of the interacting regions.

These results suggest that beside the structural differences in the active site regions of the enzymes there are specific structural determinants on the inhibitors that determine the specificity of inhibition.

Acknowledgements: We kindly thank Dr. Iztok Dolenc and M.Sc. Veronika Stoka for providing us with enzymes for kinetic studies, Dr. Boris Turk for helpful discussion and Dr. Roger Pain for critical reading of the manuscript. This work was supported by the Ministry of Science and Technology of the Republic of Slovenia.

References

- [1] Barrett, A.J., Rawlings, N.D., Davies, M.E., Machleidt, W., Salvesen, G. and Turk, V. (1986) in: *Proteinase Inhibitors*, pp. 515–569, Elsevier, Amsterdam.
- [2] Barrett, A.J., Fritz, H., Grubb, A., Isemura, S., Järvinen, M., Katunuma, N., Machleidt, W., Müller-Esterl, W., Sasaki, M. and Turk, V. (1986) *Biochem. J.* 236, 312.
- [3] Turk, V. and Bode, W. (1991) *FEBS Lett.* 285, 213–219.
- [4] Järvinen, M. (1978) *J. Invest. Dermatol.* 71, 114–118.
- [5] Järvinen, M. and Rinne, A. (1982) *Biochim. Biophys. Acta* 780, 210–217.
- [6] Brzin, J., Kopitar, M., Turk, V. and Machleidt, W. (1983) *Hoppe-Seyler's Z. Physiol. Chem.* 364, 1475–1480.
- [7] Green, G.D.J., Kembhavi, A.A., Davies, M.E. and Barrett, A.J. (1984) *Biochem. J.* 218, 939–946.
- [8] Lenarčič, B., Ritonja, A., Šali, A., Kotnik, M., Turk, V. and Machleidt, W. (1986) in: *Cysteine Proteinases and Their Inhibitors*, pp. 473–487, De Gruyter, Berlin.
- [9] Hirado, M., Iwata, D., Niiobe, M. and Fuji, S. (1981) *Biochim. Biophys. Acta* 669, 21–27.
- [10] Takeda, A., Kobayashi, S. and Samejima, T. (1983) *J. Biochem.* 94, 811–820.
- [11] Turk, B., Križaj, I. and Turk, V. (1992) *Biol. Chem. Hoppe-Seyler* 373, 441–446.
- [12] Turk, B., Križaj, I., Kralj, B., Dolenc, I., Popovič, T., Bieth, J.G. and Turk, V. (1993) *J. Biol. Chem.* 268, 7232–7329.
- [13] Turk, B., Ritonja, A., Björk, I., Stoka, V., Dolenc, I. and Turk, V. (1995) *FEBS Lett.* 360, 101–105.
- [14] Lenarčič, B., Ritonja, A., Dolenc, I., Stoka, V., Berbič, S., Pungerčar, J., Štrukelj, B. and Turk, V. (1993) *FEBS Lett.* 336, 289–292.
- [15] Bode, W., Engh, R., Musil, D., Thiele, U., Huber, R., Karshikov, A., Brzin, J., Kos, J. and Turk, V. (1988) *EMBO J.* 7, 2593–2599.
- [16] Bode, W., Engh, R., Musil, D., Huber, R., Brzin, J., Kos, J. and Turk, V. (1988) in: *Intracellular Proteolysis: Mechanisms and Regulations*, pp. 297–304, Japan Scientific Press, Tokyo.
- [17] Stubbs, M., Laber, B., Bode, W., Huber, R., Jerala, R., Lenarčič, B. and Turk, V. (1990) *EMBO J.* 9, 1939–1947.
- [18] Musil, D., Zučić, D., Turk, D., Engh, R.A., Mayr, I., Huber, R., Popovič, T., Turk, V., Towatari, T., Katunuma, N. and Bode, W. (1991) *EMBO J.* 10, 2321–2333.
- [19] Popovič, T., Brzin, J., Lenarčič, B., Machleidt, W., Ritonja, A., Hanada, K. and Turk, V. (1988) *Hoppe-Seyler's Z. Physiol. Chem.* 369, 175–183.
- [20] Turk, B., Dolenc, I., Turk, V. and Bieth, J.G. (1993) *Biochemistry* 32, 375–380.
- [21] Zvonar, T., Kregar, I. and Turk, V. (1979) *Croat. Chem. Acta* 52, 411–416.

- [22] Dolenc, I., Ritonja, A., Čolić, A., Podobnik, M., Ogrinc, T. and Turk, V. (1992) *Biol. Chem. Hoppe-Seyler* 373 (Suppl.), 407–410.
- [23] Štrop, P. and Čechova, D. (1981) *J. Chromatogr.* 207, 55–62.
- [24] Henschen, A. (1986) *Advanced Methods in Protein Microsequence Analysis*, pp. 244–255, Springer, Berlin.
- [25] Križaj, I., Turk, B. and Turk, V. (1992) *FEBS Lett.* 298, 237–239.
- [26] Butler, P.J.G. and Hartley, B.S. (1972) *Methods Enzymol.* 25, 191–199.
- [27] Barrett, A.J. and Kirschke, H. (1981) *Methods Enzymol.* 80, 535–562.
- [28] Morrison, J.F. (1982) *Trends Biochem. Sci.* 7, 102–105.
- [29] Mason, R.W. (1986) *Biochem. J.* 240, 285–288.
- [30] Leonardi, A., Turk, B. and Turk, V. (1996) *Biol. Chem. Hoppe-Seyler* 377, 319–321.
- [31] Zucker, S., Buttle, D.J., Nicklin, J.H. and Barrett, A.J. (1985) *Biochim. Biophys. Acta* 828, 196–204.
- [32] Baricos, W.H., Zhou, Y., Mason, R.W. and Barrett, A.J. (1988) *Biochem. J.* 252, 301–304.
- [33] Greco, W.R. and Hakala, M.T. (1979) *J. Biol. Chem.* 254, 12104–12109.
- [34] Takio, K., Kominami, E., Bando, Y., Katunuma, N. and Titani, K. (1984) *Biochem. Biophys. Res. Commun.* 121, 149–154.
- [35] Takio, K., Kominami, E., Wakamatsu, N., Katunuma, N. and Titani, K. (1983) *Biochem. Biophys. Res. Commun.* 115, 902–908.
- [36] Wakamatsu, N., Kominami, E., Takio, K. and Katunuma, N. (1984) *J. Biol. Chem.* 259, 13832–13838.
- [37] Nikawa, T., Towatari, T., Ike, Y. and Katunuma, N. (1989) *FEBS Lett.* 255, 309–314.
- [38] Jerala, R., Trstenjak-Prebanda, M., Kroon-Žitko, L., Lenarčič, B. and Turk, V. (1990) *Biol. Chem. Hoppe-Seyler* 371 (Suppl.), 157–160.
- [39] Auerswald, E.A., Genenger, G., Assfalg-Machleidt, I., Machleidt, W., Engh, R.A. and Fritz, H. (1992) *Eur. J. Biochem.* 209, 837–845.
- [40] Auerswald, E.A., Nägler, D.K., Assfalg-Machleidt, I., Stubbs, M.T., Machleidt, W. and Fritz, H. (1995) *FEBS Lett.* 361, 179–184.
- [41] Machleidt, W., Thiele, U., Laber, B., Assfalg-Machleidt, I., Esterl, A., Wiegand, G., Kos, J., Turk, V. and Bode, W. (1989) *FEBS Lett.* 243, 234–238.
- [42] Abrahamson, M., Mason, R.W., Hansson, H., Buttle, D.J., Grubb, A. and Ohlsson, K. (1991) *Biochem. J.* 273, 621–626.
- [43] Lindahl, P., Nycander, M., Ylinejärvi, K., Pol, E. and Björk, I. (1992) *Biochem. J.* 286, 165–171.
- [44] Lindahl, P., Ripoll, D., Abrahamson, M., Mort, J.S. and Storer, A.C. (1994) *Biochemistry* 33, 4384–4392.
- [45] Björk, I., Pol, E., Raub-Segal, E., Abrahamson, M., Rowan, A.D. and Mort, J.S. (1994) *Biochem. J.* 299, 219–225.
- [46] Abe, K., Emori, Y., Kondo, H., Arai, S. and Suzuki, K. (1988) *J. Biol. Chem.* 263, 7655–7659.
- [47] Thiele, U., Assfalg-Machleidt, I., Machleidt, W. and Auerswald, E.A. (1990) *Biol. Chem. Hoppe-Seyler* 371 (Suppl.), 125–136.
- [48] Baudyš, M., Meloun, B., Gan-Erdene, T., Fusek, M., Marek, M., Kostka, V., Pohl, J. and Blake, C.C.F. (1991) *Biomed. Biochim. Acta* 50, 569–577.