

# Cross Product Bialgebras

## Part II

Yuri Bespalov

*Bogolyubov Institute for Theoretical Physics, Metrologichna Str. 14-B,  
Kiev 252143, Ukraine*

E-mail: [mmtpitp@gluk.apc.org](mailto:mmtpitp@gluk.apc.org)

and

Bernhard Drabant

*Faculty of Mathematics, DAMTP, University of Cambridge, Silver Street,  
Cambridge CB3 9EW, United Kingdom*

E-mail: [b.drabant@damtp.cam.ac.uk](mailto:b.drabant@damtp.cam.ac.uk)

*Communicated by Susan Montgomery*

Received July 2, 1999

This is the central article of a series of three papers on cross product bialgebras. We present a universal theory of bialgebra factorizations (or cross product bialgebras) with cocycles and dual cocycles. We also provide an equivalent (co-)modular (co-)cyclic formulation. All known examples as for instance bi- or smash, double-cross and bicross product bialgebras as well as double biproduct bialgebras and bicrossed or cocycle bicross product bialgebras are now united within a single theory. Furthermore our construction yields various novel types of cross product bialgebras. © 2001 Academic Press

## 1. INTRODUCTION

By definition cross product bialgebras are isomorphic to factorizations  $B = B_1 \otimes B_2$ , in a braided category say, such that the given isomorphisms can be characterized universally in terms of certain projections and



injections from the bialgebra into the particular tensor factors. In this context tensor product bialgebras, bi- or bismash product bialgebras [24, 30], doublecross product bialgebras, bicross product bialgebras, and double biproduct bialgebras [18, 21] are cross product bialgebras. But also the bicrossed or cocycle bicross product bialgebras [22, 20] are cross product bialgebras in our terminology; their universal characterization is given in terms of cleft extensions and coextensions (see [7, 12, 23, 27] for a comprehensive study of cleft or normal basis Hopf–Galois extensions on the algebra level). The notion of cross product bialgebras therefore as well includes constructions involving cocycles and dual cocycles (or simply “cycles”). Well known examples of cross product bialgebras are Drinfel’d’s quantum double, the quantum Poincaré group, Radford’s 4-parameter Hopf algebra, Lusztig’s construction of the quantum enveloping algebra, the quantum Weyl group, the affine quantum groups  $U_q(\hat{\mathfrak{g}})$ , the Connes–Moscovici Hopf algebra in transverse differential geometry [10], etc. The universal constructions of cross product bialgebras in [18, 20, 22, 24, 30] additionally admit an equivalent characterization in terms of mutual weak (co-)modular, co-cyclic relations of the tensor factors  $B_1$  and  $B_2$ . This means that there exist certain weak (co-)multiplications, (co-)cycles, and (co-)actions which are morphisms with tensor rank  $(2, 1)$  or  $(1, 2)$  defined on  $B_1$  and  $B_2$  and their twofold tensor products, such that the multiplication  $m_B$  and the comultiplication  $\Delta_B$  of the bialgebra  $B$  can be composed monoidally by these structure morphisms. For example, we encounter a weak left coaction  $\nu_l : B_1 \rightarrow B_2 \otimes B_1$  which has tensor rank  $(1, 2)$ , a weak cocycle  $\sigma : B_2 \otimes B_2 \rightarrow B_1$  with rank  $(2, 1)$ , etc. All these structure morphisms are subject to certain relations with rank  $(2, 2)$ ,  $(3, 1)$ , and  $(1, 3)$  which on the one hand follow from the bialgebra structure of  $B = B_1 \otimes B_2$  and on the other hand determine the bialgebra structure of  $B_1 \otimes B_2$  uniquely.

Despite those common properties of the cross product bialgebra constructions in [18, 20, 22, 24, 30] no theory exists which characterizes all of them as special versions of a single universal construction which in turn is uniquely determined by its (co-)modular cocyclic structure. A first step towards this objective has been achieved in [5] where we discovered a method to describe cross product bialgebras without cocycles, generalizing and uniting [18, 21, 24].

The present article considerably extends the results of [5]. The main outcome is a universal and (co-)modular, cocyclic theory of cross product bialgebras with cocycles and cycles which unites all known constructions within a single setting and provides several new families of cross product bialgebras. This is the most comprehensive framework for cross product bialgebras so far, which equivalently takes into account both universal and (co-)modular cocyclic aspects.

Furthermore our construction is designed to work in arbitrary braided categories.<sup>1</sup>

To derive these results we will proceed in two steps. We begin with the general definition of cross product bialgebras and find a universal characterization for them. We show that so-called cocycle cross product bialgebras possess a certain (co-)modular cocyclic structure. Then we restrict our consideration to strong cross product bialgebras. They also admit a universal characterization and will turn out to be the central objects in our theory of cross product bialgebras.

In a second step we present a (co-)modular cocyclic construction method by so-called Hopf data.<sup>2</sup> A Hopf datum consists of a pair of objects  $(B_1, B_2)$  and weak (co-)actions, (co-)multiplications, and cocycles defined on  $B_1$  and  $B_2$  which obey certain interrelated identities with rank  $(2, 2)$ ,  $(3, 1)$ , and  $(1, 3)$ . Then we introduce strong Hopf data for which additional “strong” relations hold. We show that strong Hopf data induce the structure of a strong cross product bialgebra on the tensor product  $B_1 \otimes B_2$ . Strong Hopf data and strong cross product bialgebras are different depictions of the same object.

Then we combine the universal characterization and the (co-)modular cocyclic description in terms of strong Hopf data to obtain the theory of strong cross product bialgebras. This is the central result of the article. Eventually we apply our construction and investigate strong cross product bialgebras according to their (co-)modular cocyclic structure. In particular we recover all known constructions [5, 18, 20, 22, 24] and find various new types of cross product bialgebras. All of them are special versions of the most general strong cross product bialgebra construction.

After introducing preliminary notations and definitions we study cross product algebras and cross product coalgebras from a universal point of view in Section 2. These results will be used in Section 3 to define cross product bialgebras. From this general definition we extract cocycle cross product bialgebras and strong cross product bialgebras. The structure of cocycle cross product bialgebras gives useful hints for the design of Hopf data. This will be done in Section 4 where we investigate the connection of Hopf data and cocycle cross product bialgebras. A Hopf datum is canonically assigned to every cocycle cross product bialgebra. The converse is not

<sup>1</sup>Therefore we have been able to apply the results of [5] to categories of Hopf bimodules and Yetter–Drinfel’d modules [6]; we characterized two-sided bi- or bismash product bialgebras as certain cross product Hopf bimodule bialgebras. In particular we showed that the double biproduct is a twisted Hopf bimodule tensor product bialgebra.

<sup>2</sup>Observe that Hopf data without cocycles have been introduced in [5] already. There should be no confusion with the more general notation of the same name which will be defined in the present article. In a very similar context the term “Hopf datum” has been used in [1] for special cases of bicrossed product bialgebras [20].

true in general. But Theorem 4.4 states that strong Hopf data yield strong cross product bialgebras. More precisely strong Hopf data and strong cross product bialgebras are equivalent constructions which are in one-to-one correspondence. The universal (co-)modular cocyclic theory of strong cross product bialgebras culminates in the central Theorems 4.4 and 4.5. Finally we present a table of special strong cross product bialgebras which contains all known and several new types of cross product bialgebras embedded in our most general framework.

The rather intricate proof of Theorem 4.4 has been postponed to Section 5.

In the recent articles [9, 11, 26] cross product bialgebras have been studied as well. In [9] the universal properties of cocycle free cross product bialgebras have been considered. The article [11] investigates certain cross product bialgebras without co-cycles in universal and (co-)modular cocyclic terms. In [26] a special type of our cocycle cross product bialgebras with one cocycle has been studied in the special case where all objects are vector spaces over a field.

### *Preliminaries*

We are working throughout in (strict) braided monoidal categories [15]. In our article we denote categories by calligraphic letters  $\mathcal{C}$ ,  $\mathcal{D}$ , etc. For a braided monoidal category  $\mathcal{C}$  the tensor product is denoted by  $\otimes_{\mathcal{C}}$ , the unit object by  $\mathbb{1}_{\mathcal{C}}$ , and the braiding by  ${}^{\mathcal{C}}\Psi$ . If it is clear from the context we omit the index  $\mathcal{C}$  at the various symbols. We confine ourselves to braided categories which admit split idempotents [3, 17]; for each idempotent  $\Pi = \Pi^2 : M \rightarrow M$  of any object  $M$  in  $\mathcal{C}$  there exists an object  $M_{\Pi}$  and a pair of morphisms  $(i_{\Pi}, p_{\Pi})$  such that  $p_{\Pi} \circ i_{\Pi} = \text{id}_{M_{\Pi}}$  and  $i_{\Pi} \circ p_{\Pi} = \Pi$ . This is not a severe restriction of the categories since every braided category can be canonically embedded into a braided category which admits split idempotents [3, 17].

We use generalized algebraic structures like algebra, bialgebra, module, comodule, etc., in such categories. We assume the reader is familiar with these generalizations. A thorough introduction to braided algebraic structures and the graphical calculus coming along with it can be found in [13, 15–17, 19, 25, 31]. We denote by  $m : A \otimes A \rightarrow A$  the multiplication and by  $\eta : \mathbb{1} \rightarrow A$  the unit of an algebra  $A$  in  $\mathcal{C}$ .  $\Delta : C \rightarrow C \otimes C$  is meant for the comultiplication and  $\varepsilon : C \rightarrow \mathbb{1}$  for the counit of a coalgebra  $C$  in  $\mathcal{C}$ ,  $\mu_l : A \otimes M \rightarrow M$  is the left action of an algebra  $A$  on a module  $M$ , and  $\nu_l : N \rightarrow C \otimes N$  denotes the left coaction of a coalgebra  $C$  on a comodule  $N$ . Right actions are denoted by  $\mu_r$  and right coactions by  $\nu_r$ . In the course of our work we often encounter weak versions of (co-)multiplication and (co-)action which do not necessarily obey

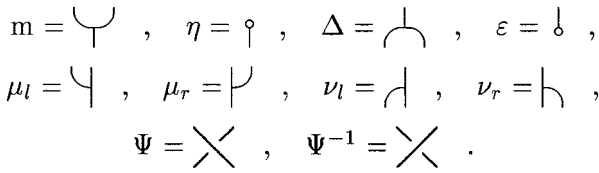

FIG. 1. Graphical presentation of (weak) multiplication  $m$ , unit  $\eta$ , (weak) comultiplication  $\Delta$ , counit  $\varepsilon$ , (weak) left action  $\mu_l$ , (weak) right action  $\mu_r$ , (weak) left coaction  $\nu_l$ , (weak) right coaction  $\nu_r$ , braiding  $\Psi$ , and inverse braiding  $\Psi^{-1}$ .

the relations of “true” (co-)algebras and (co-)modules. We will nevertheless use the same symbols as for proper (co-)multiplications and (co-)actions—it should become clear from the context whether these structure morphisms are weak or not.

In our article we make use of graphical calculus for (strict) braided monoidal categories which simplifies intricate categorical equations of morphisms and helps to uncover their intrinsic structure. Morphisms will be composed from up to down; i.e., the domains of the morphisms are at the top and the codomains are at the bottom of the graphics. Tensor products are represented by horizontal concatenation in the corresponding order. We present our own conventions [3–5] in Fig. 1. If there is no fear of confusion we omit the assignment of a specific object to the ends of the particular strings in the graphics. Below we elucidate the graphical calculus to readers unfamiliar with this technique. The first example is the associativity of the action of an algebra  $A$  on a right  $A$ -module  $M$ . The second is the naturality of the braiding in a braided category.

$$\begin{aligned}
 \mu_r \circ (\mu_r \otimes \text{id}_A) = \mu_r \circ (\text{id}_M \otimes m_A) & \quad \text{corresponds to} \quad \text{Y-shape with right line} = \text{Y-shape} , \\
 \Psi \circ (f \otimes g) = (g \otimes f) \circ \Psi & \quad \text{corresponds to} \quad \text{cross with labels} = \text{cross with labels} .
 \end{aligned}$$

Note that throughout the article there is (almost) no need to require invertibility of the braiding. Therefore most of the results can be derived if we assume that the underlying category  $\mathcal{C}$  is pre-braided. We do not discuss these generalizations further and confine our focus to braided categories in what follows.

## 2. CROSS PRODUCT ALGEBRAS AND COALGEBRAS

In the first part of Section 2 we study cross product algebras. They have been considered also in [8]. It turns out that cross product algebras are universal constructions. They generalize crossed product algebras [12, 23, 27].

Cross product coalgebras will be studied in the second part of Section 2. Since the results for cross product coalgebras can be obtained easily by certain categorical dualization, we omit all the proofs in this case and refer to the analogous proofs for cross product algebras. Both structures, cross product algebras and cross product coalgebras, will be needed later in the definition of cross product bialgebras.

### Cross Product Algebras

**DEFINITION 2.1.** Let  $(B_1, m_1, \eta_1)$  be an algebra and  $B_2$  be an object in  $\mathcal{C}$ . Suppose there are morphisms  $\eta_2 : \mathbb{1} \rightarrow B_2$ ,  $\varphi_{2,1} : B_2 \otimes B_1 \rightarrow B_1 \otimes B_2$ , and  $\hat{\sigma} : B_2 \otimes B_2 \rightarrow B_1 \otimes B_2$  such that the relation

$$\varphi_{2,1} = (m_1 \otimes \text{id}_{B_2}) \circ (\text{id}_{B_1} \otimes \hat{\sigma}) \circ (\varphi_{2,1} \otimes \eta_2) \quad (2.1)$$

holds. Suppose further that  $B = B_1 \otimes B_2$  is an algebra through

$$\begin{aligned} m_B &= (m_1 \otimes \text{id}_{B_2}) \circ (m_1 \otimes \hat{\sigma}) \circ (\text{id}_{B_1} \otimes \varphi_{2,1} \otimes \text{id}_{B_2}), \\ \eta_B &= \eta_1 \otimes \eta_2. \end{aligned} \quad (2.2)$$

Then  $B$  is called a cross product algebra and will be denoted by  $B_1 \bowtie_{\varphi_{2,1}}^{\hat{\sigma}} B_2$ .

In the subsequent proposition we find equivalent constructive conditions for cross product algebras. Similar results have been obtained in [8].

**PROPOSITION 2.2.** *The following statements are equivalent.*

- (1)  $B_1 \bowtie_{\varphi_{2,1}}^{\hat{\sigma}} B_2$  is a cross product algebra.
- (2)  $(B_1, m_1, \eta_1)$  is an algebra and  $B_2$  is an object in  $\mathcal{C}$ . There exist morphisms  $\eta_2 : \mathbb{1} \rightarrow B_2$ ,  $\varphi_{2,1} : B_2 \otimes B_1 \rightarrow B_1 \otimes B_2$  and  $\hat{\sigma} : B_2 \otimes B_2 \rightarrow B_1 \otimes B_2$  for which the subsequent identities hold,

$$\begin{aligned} \varphi_{2,1} \circ (\eta_2 \otimes \text{id}_{B_1}) &= \text{id}_{B_1} \otimes \eta_2, & \hat{\sigma} \circ (\eta_2 \otimes \text{id}_{B_2}) &= \eta_1 \otimes \text{id}_{B_2}, \\ \varphi_{2,1} \circ (\text{id}_{B_2} \otimes \eta_1) &= \eta_1 \otimes \text{id}_{B_2}, & \hat{\sigma} \circ (\text{id}_{B_2} \otimes \eta_2) &= \eta_1 \otimes \text{id}_{B_2}, \\ \varphi_{2,1} \circ (\text{id}_{B_2} \otimes m_1) &= (m_1 \otimes \text{id}_{B_2}) \circ (\text{id}_{B_1} \otimes \varphi_{2,1}) \circ (\varphi_{2,1} \otimes \text{id}_{B_1}), \\ (m_1 \otimes \text{id}_{B_2}) \circ (\text{id}_{B_1} \otimes \hat{\sigma}) \circ (\varphi_{2,1} \otimes \text{id}_{B_2}) \circ (\text{id}_{B_2} \otimes \hat{\sigma}) & & (2.3) \\ &= (m_1 \otimes \text{id}_{B_2}) \circ (\text{id}_{B_1} \otimes \hat{\sigma}) \circ (\hat{\sigma} \otimes \text{id}_{B_2}), \\ (m_1 \otimes \text{id}_{B_2}) \circ (\text{id}_{B_1} \otimes \hat{\sigma}) \circ (\varphi_{2,1} \otimes \text{id}_{B_2}) \circ (\text{id}_{B_2} \otimes \varphi_{2,1}) & & \\ &= (m_1 \otimes \text{id}_{B_2}) \circ (\text{id}_{B_1} \otimes \varphi_{2,1}) \circ (\hat{\sigma} \otimes \text{id}_{B_1}). \end{aligned}$$

*Proof.* Suppose that  $B_1 \bowtie_{\varphi_{2,1}}^{\hat{\sigma}} B_2$  is a cross product algebra. Since by assumption  $(B_1, m_1, \eta_1)$  is itself an algebra one obtains the first and second identity of (2.3) by unitality of  $m_B$  and  $m_1$ . Using these relations yields the

fourth identity of (2.3) by application of  $\text{id}_{B_2} \otimes \eta_1$  to (2.1). Again using the left unitality of  $\mathfrak{m}_B$  one concludes that  $(\mathfrak{m}_1 \otimes \text{id}_{B_2}) \circ (\text{id}_{B_1} \otimes \hat{\sigma} \circ (\eta_2 \otimes \text{id}_{B_2})) = \text{id}_{B_1} \otimes \text{id}_{B_2}$  from which one immediately derives the third identity of (2.3). Now the associativity  $\mathfrak{m}_B \circ (\mathfrak{m}_B \otimes \text{id}_B) = \mathfrak{m}_B \circ (\text{id}_B \otimes \mathfrak{m}_B)$  yields the fifth identity of (2.3) by application of  $\eta_1 \otimes \text{id} \otimes \text{id} \otimes \eta_1 \otimes \text{id} \otimes \eta_2$ . The sixth relation is obtained by applying  $\eta_1 \otimes \text{id} \otimes \eta_1 \otimes \text{id} \otimes \eta_1 \otimes \text{id}$ . To derive the seventh identity one has to apply  $\eta_1 \otimes \text{id} \otimes \eta_1 \otimes \text{id} \otimes \text{id} \otimes \eta_2$ . Conversely suppose the conditions of the second item of the proposition are fulfilled. Define  $\mathfrak{m}_B$  according to (2.2). Then  $\mathfrak{m}_B \circ (\mathfrak{m}_B \otimes \text{id}_B) = (\mathfrak{m}_1^{(5)} \otimes \text{id}) \circ (\text{id}^{(4)} \otimes \hat{\sigma}) \circ (\text{id}^{(3)} \otimes \varphi_{2,1} \otimes \text{id}) \circ (\text{id}^{(2)} \otimes \hat{\sigma} \otimes \text{id}^{(2)}) \circ (\text{id} \otimes \varphi_{2,1} \otimes \text{id}^{(3)})$  where  $\mathfrak{m}_1^{(n)} : B_1^{\otimes n} \rightarrow B_1$  is the canonical  $n$ -fold multiplication, and  $\text{id}^{(n)}$  is the abbreviation of the identity of an  $n$ -fold tensor product of (combined)  $B_1$ 's and  $B_2$ 's. On the other hand

$$\begin{aligned} \mathfrak{m}_B \circ (\text{id}_B \otimes \mathfrak{m}_B) &= (\mathfrak{m}_1^{(4)} \otimes \text{id}) \circ (\text{id}^{(4)} \otimes \hat{\sigma}) \circ (\text{id}^{(3)} \otimes \varphi_{2,1} \otimes \text{id}) \\ &\quad \circ (\text{id}^{(2)} \otimes \varphi_{2,1} \otimes \hat{\sigma}) \circ (\text{id} \otimes \varphi_{2,1} \otimes \varphi_{2,1} \otimes \text{id}) \\ &= (\mathfrak{m}_1^{(5)} \otimes \text{id}) \circ (\text{id}^{(4)} \otimes \hat{\sigma}) \circ (\text{id}^{(3)} \otimes \hat{\sigma} \otimes \text{id}) \\ &\quad \circ (\text{id}^{(2)} \otimes \varphi_{2,1} \otimes \text{id}^{(2)}) \circ (\text{id} \otimes \varphi_{2,1} \otimes \varphi_{2,1} \otimes \text{id}) \\ &= (\mathfrak{m}_1^{(5)} \otimes \text{id}) \circ (\text{id}^{(4)} \otimes \hat{\sigma}) \circ (\text{id}^{(3)} \otimes \varphi_{2,1} \otimes \text{id}) \\ &\quad \circ (\text{id}^{(2)} \otimes \hat{\sigma} \otimes \text{id}^{(2)}) \circ (\text{id} \otimes \varphi_{2,1} \otimes \text{id}^{(3)}), \end{aligned}$$

where the fourth condition of (2.3) has been used twice to obtain the first equation, the sixth relation of (2.3) has been applied in the second equation, and with the help of the seventh relation of (2.3) we obtained the third equation. Hence associativity of  $\mathfrak{m}_B$  has been proven. Using the first four identities of (2.3) one easily proves (2.1) and unitality  $\mathfrak{m}_B \circ (\eta_B \otimes \text{id}_B) = \text{id}_B = \mathfrak{m}_B \circ (\text{id}_B \otimes \eta_B)$ . ■

*Remark 1.* Condition (2.1) in Definition 2.1 can be replaced equivalently by the identity  $(\text{id}_{B_1} \otimes \hat{\sigma}) = (\mathfrak{m}_1 \otimes \text{id}_{B_2}) \circ (\text{id}_{B_1} \otimes \hat{\sigma}) \circ (\varphi_{2,1} \circ (\text{id}_{B_2} \otimes \eta_1) \otimes \text{id}_{B_2})$ .

*Remark 2.* There is another equivalent definition of cross product algebras which has been kindly reported to us by Gigel Militaru. Observe that the morphism  $\Gamma$  below is our morphism  $\mathfrak{m}_{0,20}$  in (5.22). Then the following statements are equivalent.

(1)  $B_1 \bowtie_{\varphi_{2,1}}^{\hat{\sigma}} B_2$  is a cross product algebra.

(2)  $(B_1, \mathfrak{m}_1, \eta_1)$  is an algebra and  $B_2$  is an object in  $\mathcal{C}$ . There are morphisms  $\eta_2 : \mathbb{1} \rightarrow B_2$  and  $\Gamma : B_2 \otimes B_1 \otimes B_2 \rightarrow B_1 \otimes B_2$  such that  $B = B_1 \otimes B_2$  is an algebra through

$$\mathfrak{m}_B = (\mathfrak{m}_1 \otimes \text{id}_{B_2}) \circ (\text{id}_{B_1} \otimes \Gamma) \quad \text{and} \quad \eta_B = \eta_1 \otimes \eta_2. \tag{2.4}$$

(3)  $(B_1, m_1, \eta_1)$  is an algebra and  $B_2$  is an object in  $\mathcal{C}$ . There exist morphisms  $\eta_2 : \mathbb{1} \rightarrow B_2$  and  $\Gamma : B_2 \otimes B_1 \otimes B_2 \rightarrow B_1 \otimes B_2$  such that

$$\begin{aligned} \Gamma \circ (\eta_2 \otimes \text{id}_{B_1 \otimes B_2}) &= \text{id}_{B_1 \otimes B_2}, & \Gamma \circ (\text{id}_{B_2} \otimes \eta_1 \otimes \eta_2) &= \eta_1 \otimes \text{id}_{B_2}, \\ (m_1 \otimes \text{id}_{B_2}) \circ (\text{id}_{B_1} \otimes \Gamma) \circ (\Gamma \otimes \text{id}_{B_1 \otimes B_2}) & & & \\ &= \Gamma \circ (\text{id}_{B_2} \otimes (m_1 \otimes \text{id}_{B_2}) \circ (\text{id}_{B_1} \otimes \Gamma)). \end{aligned} \quad (2.5)$$

The one-to-one correspondence is given by  $\Gamma = (m_1 \otimes \text{id}_{B_2}) \circ (\text{id}_{B_1} \otimes \hat{\sigma}) \circ (\varphi_{2,1} \otimes \text{id}_{B_2})$  and its inverse  $\varphi_{2,1} = \Gamma \circ (\text{id}_{B_2 \otimes B_1} \otimes \eta_2)$  and  $\hat{\sigma} = \Gamma \circ (\text{id}_{B_2} \otimes \eta_1 \otimes \text{id}_{B_2})$ .

We will show that cross product algebras are universal constructions. The first proposition describes equivalent projection and injection conditions for algebras isomorphic to cross product algebras (see also [5] for the cocycle-free case). The second proposition is closely related to the first one and characterizes the universal construction explicitly.

**PROPOSITION 2.3.** *Let  $A$  be an algebra in  $\mathcal{C}$ . Then it holds equivalently*

- (1)  $A$  is an algebra isomorphic to a cross product algebra  $B_1 \bowtie_{\varphi_{2,1}}^{\hat{\sigma}} B_2$ .
- (2) There is an algebra  $(B_1, m_1, \eta_1)$ , an object  $B_2$ , morphisms  $B_1 \xrightarrow{i_1} A \xleftarrow{i_2} B_2$ , and  $\eta_2 : \mathbb{1} \rightarrow B_2$  where  $i_1$  is an algebra morphism and  $i_2 \circ \eta_2 = \eta_A$  such that  $m_A \circ (i_1 \otimes i_2) : B_1 \otimes B_2 \rightarrow A$  is an isomorphism in  $\mathcal{C}$ .

*Proof.* If  $\Lambda : B_1 \bowtie_{\varphi_{2,1}}^{\hat{\sigma}} B_2 \rightarrow A$  is an algebra isomorphism then define  $i_1 := \Lambda \circ (\text{id}_{B_1} \otimes \eta_2)$  and  $i_2 := \Lambda \circ (\eta_1 \otimes \text{id}_{B_2})$ . Using the particular definition of  $m_{B_1 \bowtie_{\varphi_{2,1}}^{\hat{\sigma}} B_2}$  in (2.2) and the identities (2.1), it is verified immediately that  $i_1$  is an algebra morphism since  $\Lambda$  is an algebra morphism. Similarly one proves that  $i_2 \circ \eta_2 = \eta_A$  and  $m_A \circ (i_1 \otimes i_2) = \Lambda$  which is therefore an isomorphism. If on the other hand the conditions of the second statement of Proposition 2.3 is fulfilled, then  $\Lambda := m_A \circ (i_1 \otimes i_2)$  is an isomorphism by assumption. Therefore  $B = B_1 \otimes B_2$  is canonically an algebra through  $m_B := \Lambda^{-1} \circ m_A \circ (\Lambda \otimes \Lambda)$  and  $\eta_B := \Lambda^{-1} \circ \eta_A$ . We will show that this defines a cross product algebra structure on  $B$  by  $\varphi_{2,1} := \Lambda^{-1} \circ m_A \circ (i_2 \otimes i_1)$  and  $\hat{\sigma} := \Lambda^{-1} \circ m_A \circ (i_2 \otimes i_2)$ . Using the explicit expression for  $\Lambda$ , inserting several times  $\Lambda \circ \Lambda^{-1}$ , and using the above definitions, as well as the fact that  $i_1$  is algebra morphism, one obtains the identities

$$\begin{aligned} m_B &= \Lambda^{-1} \circ m_A^{(3)} \circ (\text{id} \otimes \Lambda \circ \Lambda^{-1} \otimes \text{id}) \circ (i_1 \otimes m_A \circ (i_2 \otimes i_1) \otimes i_2) \\ &= \Lambda^{-1} \circ m_A^{(4)} \circ (i_1 \otimes (i_1 \otimes i_2) \circ \varphi_{2,1} \otimes i_2) \\ &= \Lambda^{-1} \circ m_A^{(3)} \circ (i_1 \otimes i_1 \otimes i_2) \circ (m_1 \otimes \hat{\sigma}) \circ (\text{id} \otimes \varphi_{2,1} \otimes \text{id}) \\ &= (m_1 \otimes \text{id}) \circ (m_1 \otimes \hat{\sigma}) \circ (\text{id} \otimes \varphi_{2,1} \otimes \text{id}). \end{aligned}$$



Similarly one derives  $\Lambda \circ (\eta_1 \otimes \eta_2) = \eta_A$ , hence  $\eta_B = \eta_1 \otimes \eta_2$ . Therefore  $(B, m_B, \eta_B) = B_1 \bowtie_{\varphi_{2,1}}^{\hat{\sigma}} B_2$ . ■

PROPOSITION 2.4. *Let  $B_1 \bowtie_{\varphi_{2,1}}^{\hat{\sigma}} B_2$  be a cross product algebra, and  $A$  be an algebra. Suppose there are morphisms  $\alpha : B_1 \rightarrow A$  and  $\beta : B_2 \rightarrow A$  such that*

- (1)  $\alpha$  is an algebra morphism.
- (2)  $\beta \circ \eta_2 = \eta_A$ .
- (3)  $m_A \circ (\alpha \otimes \beta) \circ \varphi_{2,1} = m_A \circ (\beta \otimes \alpha)$ .
- (4)  $m_A \circ (\alpha \otimes \beta) \circ \hat{\sigma} = m_A \circ (\beta \otimes \beta)$ .

Then there exists a unique algebra morphism  $\gamma : B_1 \bowtie_{\varphi_{2,1}}^{\hat{\sigma}} B_2 \rightarrow A$  obeying the identities  $\gamma \circ (\text{id}_{B_1} \otimes \eta_2) = \alpha$  and  $\gamma \circ (\eta_1 \otimes \text{id}_{B_2}) = \beta$ .

*Proof.* Define  $\gamma := m_A \circ (\alpha \otimes \beta)$ . Then by assumptions (1) and (2) of Proposition 2.4 it follows  $\gamma \circ (\text{id}_{B_1} \otimes \eta_2) = \alpha$ ,  $\gamma \circ (\eta_1 \otimes \text{id}_{B_2}) = \beta$ , and  $\gamma \circ (\eta_1 \otimes \eta_2) = \eta_A$ . Using consecutively that  $\alpha$  is an algebra morphism, assumption (4), and assumption (3) of Proposition 2.4 then yields  $\gamma \circ m_{B_1 \bowtie_{\varphi_{2,1}}^{\hat{\sigma}} B_2} = m_A^{(4)} \circ (\alpha \otimes \alpha \otimes (\alpha \otimes \beta) \circ \hat{\sigma}) \circ (\text{id} \otimes \varphi_{2,1} \otimes \text{id}) = m_A^{(4)} \circ (\alpha \otimes (\alpha \otimes \beta) \circ \varphi_{2,1} \otimes \beta) = m_A \circ (m_A \circ (\alpha \otimes \beta) \otimes m_A \circ (\alpha \otimes \beta)) = m_A \circ (\gamma \otimes \gamma)$ . Therefore  $\gamma$  is an algebra morphism obeying the conditions of Proposition 2.4. Suppose that there is another  $\gamma'$  meeting the same stipulations as  $\gamma$ . Then  $\gamma = m_A \circ (\alpha \otimes \beta) = m_A \circ (\gamma' \circ (\text{id} \otimes \eta_2) \otimes \gamma' \circ (\eta_1 \otimes \text{id})) = \gamma' \circ m_{B_1 \bowtie_{\varphi_{2,1}}^{\hat{\sigma}} B_2} \circ (\text{id} \otimes \eta_2 \otimes \eta_1 \otimes \text{id}) = \gamma'$ . In the last equation unital properties of cross product algebra have been used. This proves uniqueness of  $\gamma$ . ■

Remark 3. The conditions of Proposition 2.4 can be realized on  $A = B_1 \bowtie_{\varphi_{2,1}}^{\hat{\sigma}} B_2$  with  $\alpha = \text{id}_{B_1} \otimes \eta_2$  and  $\beta = \eta_1 \otimes \text{id}_{B_2}$ . Then of course  $\gamma = \text{id}$ .

In the following we consider generalized smash product algebras [5] and demonstrate that they are special cases of cross product algebras.<sup>3</sup> A (generalized) *smash product algebra*  $B_1 \times_{\phi_{2,1}} B_2$  consists of algebras  $B_1$  and  $B_2$ , and a morphism  $\phi_{2,1} : B_2 \otimes B_1 \rightarrow B_1 \otimes B_2$ , such that  $B = B_1 \otimes B_2$  is an algebra through  $m_B = (m_1 \otimes m_2) \circ (\text{id}_{B_1} \otimes \phi_{2,1} \otimes \text{id}_{B_2})$  and  $\eta_B = \eta_1 \otimes \eta_2$ . The next proposition shows that smash product algebras are indeed special cases of cross product algebras under certain natural conditions.

<sup>3</sup>We adopt the name “smash product algebras” from [9].

PROPOSITION 2.5. *Suppose there is a morphism  $\varepsilon_1 : B_1 \rightarrow \mathbb{1}$  with  $\varepsilon_1 \circ \eta_1 = \text{id}_{\mathbb{1}}$ . Then*

*$B_1 \bowtie_{\varphi_{2,1}}^{\hat{\sigma}} B_2$  is a cross product algebra with  $\hat{\sigma} = \eta_1 \otimes m_2$  for some morphism  $m_2 : B_2 \otimes B_2 \rightarrow B_2 \Leftrightarrow B_1 \times_{\varphi_{2,1}} B_2$  is a smash product algebra*

*Proof.* The proposition can be proven easily by (2.3) and triviality of  $\hat{\sigma}$ . ■

*Remark 4.* Crossed product algebras  $A \#_{\sigma} H$  [12, 23] are special examples of cross product algebras through  $\varphi_{2,1} := (\mu_l \otimes \text{id}_H) \circ (\Delta_H \otimes \text{id}_A)$  and  $\hat{\sigma} := (\sigma \otimes m_H) \circ (\text{id}_H \otimes \Psi_{H,H} \otimes \text{id}_H) \circ (\Delta_H \otimes \Delta_H)$  where  $A$  is an algebra,  $\mu_l : H \otimes A \rightarrow A$  is a left  $H$ -measure on  $A$ , and  $\sigma : H \otimes H \rightarrow A$  is a (convolution invertible) cocycle.

The next proposition yields criteria under which a morphism  $f : B_1 \bowtie_{\varphi_{2,1}}^{\hat{\sigma}} B_2 \rightarrow A$  is multiplicative.

PROPOSITION 2.6. *Let  $A$  be an algebra and  $B = B_1 \bowtie_{\varphi_{2,1}}^{\hat{\sigma}} B_2$  be a cross product algebra. Then the subsequent statements are equivalent.*

(1) *The morphism  $f : B \rightarrow A$  is multiplicative, i.e.,  $f \circ m_B = m_A \circ (f \otimes f)$ .*

(2) *The identities*

$$m_A \circ (f \otimes f) \circ (\text{id}_{B_1} \otimes \eta_2 \otimes \text{id}_{B_1} \otimes \text{id}_{B_2}) = f \circ m_B \circ (\text{id}_{B_1} \otimes \eta_2 \otimes \text{id}_{B_1} \otimes \text{id}_{B_2}),$$

$$m_A \circ (f \otimes f) \circ (\eta_1 \otimes \text{id}_{B_2} \otimes \text{id}_{B_1} \otimes \text{id}_{B_2}) = f \circ m_B \circ (\eta_1 \otimes \text{id}_{B_2} \otimes \text{id}_{B_1} \otimes \text{id}_{B_2})$$

*are satisfied.*

(3) *The identities*

$$m_A \circ (f \otimes f) \circ (\text{id}_{B_1} \otimes \text{id}_{B_2} \otimes \text{id}_{B_1} \otimes \eta_2) = f \circ m_B \circ (\text{id}_{B_1} \otimes \text{id}_{B_2} \otimes \text{id}_{B_1} \otimes \eta_2),$$

$$m_A \circ (f \otimes f) \circ (\text{id}_{B_1} \otimes \text{id}_{B_2} \otimes \eta_1 \otimes \text{id}_{B_2}) = f \circ m_B \circ (\text{id}_{B_1} \otimes \text{id}_{B_2} \otimes \eta_1 \otimes \text{id}_{B_2})$$

*are satisfied.*

(4) *The identities*

$$m_A \circ (f \otimes f) \circ (\text{id}_{B_1} \otimes \eta_2 \otimes \text{id}_{B_1} \otimes \text{id}_{B_2}) = f \circ m_B \circ (\text{id}_{B_1} \otimes \eta_2 \otimes \text{id}_{B_1} \otimes \text{id}_{B_2}),$$

$$m_A \circ (f \otimes f) \circ (\text{id}_{B_1} \otimes \text{id}_{B_2} \otimes \eta_1 \otimes \text{id}_{B_2}) = f \circ m_B \circ (\text{id}_{B_1} \otimes \text{id}_{B_2} \otimes \eta_1 \otimes \text{id}_{B_2}),$$

$$m_A \circ (f \otimes f) \circ (\eta_1 \otimes \text{id}_{B_2} \otimes \text{id}_{B_1} \otimes \eta_2) = f \circ m_B \circ (\eta_1 \otimes \text{id}_{B_2} \otimes \text{id}_{B_1} \otimes \eta_2)$$

*are satisfied.*

*Proof.* The non-trivial part of the proposition can be verified easily with the help of the identity  $m_B \circ (\text{id} \otimes \eta_2 \otimes \eta_1 \otimes \text{id}) = \text{id} \otimes \text{id}$ , the associativity of  $A$  and  $B$ , and the assumptions 2.6.2, 2.6.3, or 2.6.4, respectively. ■

*Cross Product Coalgebras*

Cross product coalgebras are somehow dual constructions to cross product algebras. We will omit proofs since they can be obtained from the corresponding proofs for cross product algebras by an obvious kind of dualization.

**DEFINITION 2.7.** Let  $(C_2, \Delta_2, \varepsilon_2)$  be a coalgebra and  $C_1$  be an object in  $\mathcal{C}$ . Suppose there exist morphisms  $\varepsilon_1 : B_1 \rightarrow \mathbb{1}$ ,  $\varphi_{1,2} : C_1 \otimes C_2 \rightarrow C_2 \otimes C_1$ ,  $\hat{\rho} : C_1 \otimes C_2 \rightarrow C_1 \otimes C_1$  such that the relation  $\varphi_{1,2} = (\varepsilon_1 \otimes \varphi_{1,2}) \circ (\hat{\rho} \otimes \text{id}_{C_2}) \circ (\text{id}_{C_1} \otimes \Delta_2)$  holds. Then  $C = C_1 \otimes C_2$  is called a cross product coalgebra if it is a coalgebra through  $\Delta_C = (\text{id}_{B_1} \otimes \varphi_{1,2} \otimes \text{id}_{B_2}) \circ (\hat{\rho} \otimes \Delta_2) \circ (\text{id}_{B_1} \otimes \Delta_2)$  and  $\varepsilon_C = \varepsilon_1 \otimes \varepsilon_2$ . We denote  $C$  by  $C_1 \overset{\hat{\rho}}{\varphi_{1,2}} \bowtie C_2$ .

**PROPOSITION 2.8.** *The following statements are equivalent.*

(1)  $C_1 \overset{\hat{\rho}}{\varphi_{1,2}} \bowtie C_2$  is a cross product coalgebra.

(2)  $(C_2, \Delta_2, \varepsilon_2)$  is a coalgebra and  $C_1$  is an object in  $\mathcal{C}$ . There are morphisms  $\varepsilon_1 : B_1 \rightarrow \mathbb{1}$  and  $\varphi_{1,2} : C_1 \otimes C_2 \rightarrow C_2 \otimes C_1$  such that

$$\begin{aligned} (\text{id}_{C_2} \otimes \varepsilon_1) \circ \varphi_{1,2} &= \varepsilon_1 \otimes \text{id}_{C_2}, & (\text{id}_{C_1} \otimes \varepsilon_1) \circ \hat{\rho} &= \text{id}_{C_1} \otimes \varepsilon_2, \\ (\varepsilon_1 \otimes \text{id}_{C_2}) \circ \varphi_{1,2} &= \text{id}_{C_2} \otimes \varepsilon_1, & (\varepsilon_1 \otimes \text{id}_{C_1}) \circ \hat{\rho} &= \text{id}_{C_1} \otimes \varepsilon_2, \\ (\Delta_2 \otimes \text{id}_{C_1}) \circ \varphi_{1,2} &= (\text{id}_{C_2} \otimes \varphi_{1,2}) \circ (\varphi_{1,2} \otimes \text{id}_{C_2}) \circ (\text{id}_{C_1} \otimes \Delta_2), \\ (\hat{\rho} \otimes \text{id}_{C_1}) \circ (\text{id}_{C_1} \otimes \varphi_{1,2}) \circ (\hat{\rho} \otimes \text{id}_{C_2}) \circ (\text{id}_{C_1} \otimes \Delta_2) \\ &= (\text{id}_{C_1} \otimes \hat{\rho}) \circ (\hat{\rho} \otimes \text{id}_{C_2}) \circ (\text{id}_{C_1} \otimes \Delta_2), \\ (\varphi_{1,2} \otimes \text{id}_{C_1}) \circ (\text{id}_{C_1} \otimes \varphi_{1,2}) \circ (\hat{\rho} \otimes \text{id}_{C_2}) \circ (\text{id}_{C_1} \otimes \Delta_2) \\ &= (\text{id}_{C_2} \otimes \hat{\rho}) \circ (\varphi_{1,2} \otimes \text{id}_{C_2}) \circ (\text{id}_{C_1} \otimes \Delta_2). \end{aligned}$$

Like cross product algebras the cross product coalgebras are universal constructions, too.

**PROPOSITION 2.9.** *Let  $C$  be a coalgebra. Then*

$C$  is coalgebra isomorphic to a cross product coalgebra  $C_1 \overset{\hat{\rho}}{\varphi_{1,2}} \bowtie C_2$   
 $\Leftrightarrow$  there is a coalgebra  $(C_2, \Delta_2, \varepsilon_2)$  and an object  $C_1$  in  $\mathcal{C}$ , morphisms  $C_1 \xleftarrow{p_1} C \xrightarrow{p_2} C_2$ , and  $\varepsilon_1 : C_1 \rightarrow \mathbb{1}$  where  $p_2$  is a coalgebra morphism and  $\varepsilon_1 \circ p_1 = \varepsilon_C$  such that  $(p_1 \otimes p_2) \circ \Delta_C : C \rightarrow C_1 \otimes C_2$  is an isomorphism in  $\mathcal{C}$ .

**PROPOSITION 2.10.** *Let  $C_1 \overset{\hat{\rho}}{\varphi_{1,2}} \bowtie C_2$  be a cross product coalgebra and  $C$  be a coalgebra. Suppose that there exist morphisms  $a$  and  $b$  such that*

(1)  $a : C \rightarrow C_1$  and  $\varepsilon_1 \circ a = \varepsilon_C$ .

- (2)  $b : C \rightarrow C_2$  is a coalgebra morphism.  
 (3)  $\varphi_{1,2} \circ (a \otimes b) \circ \Delta_C = (b \otimes a) \circ \Delta_C$ .  
 (4)  $\hat{\rho} \circ (a \otimes b) \circ \Delta_C = (a \otimes a) \circ \Delta_C$ .

Then there exists a unique coalgebra morphism  $c : C \rightarrow C_1 \times_{\varphi_{1,2}}^{\hat{\rho}} C_2$  obeying the identities  $a = (\text{id}_{C_1} \otimes \varepsilon_2) \circ c$  and  $b = (\varepsilon_1 \otimes \text{id}_{C_2}) \circ c$ .

Co-smash product coalgebras are special cases of cross product coalgebras. More precisely, a *co-smash product coalgebra*  $C = C_1 \times^{\phi_{1,2}} C_2$  is given by coalgebras  $C_1$  and  $C_2$ , and a morphism  $\phi_{1,2} : C_1 \otimes C_2 \rightarrow C_2 \otimes C_1$ , such that  $C = C_1 \otimes C_2$  is a coalgebra through  $\Delta_C = (\text{id}_{C_1} \otimes \phi_{1,2} \otimes \text{id}_{C_2}) \circ (\Delta_1 \otimes \Delta_2)$  and  $\varepsilon_C = \varepsilon_{C_1} \otimes \varepsilon_{C_2}$ . Then the corresponding result of Proposition 2.5 holds for co-smash product coalgebras.

**PROPOSITION 2.11.** *Suppose  $C_2$  is a coalgebra and there is a morphism  $\eta_2 : \mathbb{1} \rightarrow C_2$  with  $\varepsilon_2 \circ \eta_2 = \text{id}_{\mathbb{1}}$ . Then*

*$(C_1, C_2, \varphi_{1,2}, \hat{\rho})$  is a cross product coalgebra with  $\hat{\rho} = \Delta_1 \otimes \varepsilon_2$  for some morphism  $\Delta_2 : C_2 \rightarrow C_2 \otimes C_2 \Leftrightarrow C_1 \times^{\varphi_{1,2}} C_2$  is a co-smash product coalgebra.*

*Remark 5 ( $\pi$ -Symmetry).* We would like to point out the following important observation to the reader. Definition 2.1 is not dual to Definition 2.7. Rather, both definitions can be obtained from each other by a combination of duality (followed by the usual exchanges of multiplication and comultiplication, unit and counit, cocycle and cycle, etc.) and use of the opposite tensor product (followed by exchange of indices “ $1 \leftrightarrow 2$ ,” and later also by exchange of “left/right (coaction)  $\leftrightarrow$  right/left (action)” ). This is not an accidental fact but has to do with the subsequent definition of cross product bialgebras where we use precisely these algebra and coalgebra structures. Only then are we able to get all the known cross product bialgebras [5, 18, 20, 22, 24]. This kind of symmetry between a cross product algebra and cross product coalgebra will be called  $\pi$ -symmetry henceforth. In terms of graphical calculus  $\pi$ -symmetry can be interpreted easily as rotation of the graphic by the angle  $\pi$  along an axis normal to the planar graphic followed by the above mentioned exchanges of indices and morphism types. We will often apply this principle to obtain  $\pi$ -symmetric results simply by  $\pi$ -rotation. Hence cross product bialgebras—as defined below—are therefore  $\pi$ -symmetric invariant rather than dual symmetric invariant. Dualization of our definition would lead to another kind of cross product bialgebras. The corresponding results for these dual versions follow from our results straightforwardly by dualization.

### 3. CROSS PRODUCT BIALGEBRAS

In Section 3 we investigate cross product bialgebras from a universal point of view. They are simultaneously cross product algebras and cross product coalgebras with compatible bialgebra structure. We find a universal description for the isomorphism classes of cross product bialgebras. Then we will consider special cases called cocycle and strong cross product bialgebras which are universal constructions as well. But in addition the given isomorphism class of a cocycle/strong cross product bialgebra can be characterized by certain interrelated (co-)modular cocyclic structures on the tensor factors. Strong cross product bialgebras are the pivotal objects for the studies in Section 4.

#### Cross Product Bialgebras—General Definition

DEFINITION 3.1. A bialgebra  $B$  is called a cross product bialgebra if its underlying algebra is a cross product algebra  $B_1 \bowtie_{\varphi_{2,1}}^{\hat{\sigma}} B_2$ , and its underlying coalgebra is a cross product coalgebra  $B_1 \hat{\bowtie}_{\varphi_{1,2}} B_2$  on the same objects. The cross product bialgebra  $B$  will be denoted by  $B_1 \hat{\bowtie}_{\varphi_{1,2}}^{\hat{\sigma}} B_2$ . A cross product bialgebra is called normalized if  $\varepsilon_1 \circ \eta_1 = \text{id}_{\mathbb{1}}$  (and then equivalently  $\varepsilon_2 \circ \eta_2 = \text{id}_{\mathbb{1}}$ ).

Cross product bialgebras are universal in the following sense.

THEOREM 3.2. Let  $B$  be a bialgebra in  $\mathcal{C}$ . Then the subsequent equivalent conditions hold.

(1)  $B$  is a bialgebra isomorphic to a normalized cross product bialgebra  $B_1 \hat{\bowtie}_{\varphi_{1,2}}^{\hat{\sigma}} B_2$ .

(2) There are idempotents  $\Pi_1, \Pi_2 \in \text{End}(B)$  such that

$$\begin{aligned} m_B \circ (\Pi_1 \otimes \Pi_1) &= \Pi_1 \circ m_B \circ (\Pi_1 \otimes \Pi_1), & \Pi_1 \circ \eta_B &= \eta_B, \\ (\Pi_2 \otimes \Pi_2) \circ \Delta_B &= (\Pi_2 \otimes \Pi_2) \circ \Delta_B \circ \Pi_2, & \varepsilon_B \circ \Pi_2 &= \varepsilon_B, \end{aligned} \tag{3.1}$$

and the sequence  $B \otimes B \xrightarrow{m_B \circ (\Pi_1 \otimes \Pi_2)} B \xrightarrow{(\Pi_1 \otimes \Pi_2) \circ \Delta_B} B \otimes B$  is a splitting of the idempotent  $\Pi_1 \otimes \Pi_2$  of  $B \otimes B$ .

(3) There are objects  $B_1$  and  $B_2$  and morphisms  $B_1 \xrightarrow{i_1} B \xrightarrow{p_1} B_1$  and  $B_2 \xrightarrow{i_2} B \xrightarrow{p_2} B_2$  where  $i_1$  is an algebra morphism,  $p_2$  is a coalgebra morphism, and  $p_j \circ i_j = \text{id}_{B_j}$  for  $j \in \{1, 2\}$  such that  $m_B \circ (i_1 \otimes i_2) : B_1 \otimes B_2 \rightarrow B$  and  $(p_1 \otimes p_2) \circ \Delta_B : B \rightarrow B_1 \otimes B_2$  are mutually inverse isomorphisms.

Proof. (2)  $\Rightarrow$  (3). For  $j \in \{1, 2\}$  we define  $i_j, p_j$  to be the morphisms splitting the idempotent  $\Pi_j$  as  $\Pi_j = i_j \circ p_j$  and  $p_j \circ i_j = \text{id}_{B_j}$  for some objects  $B_j$ . Then with the help of Theorem 3.2.2 it follows

$m_B \circ (i_1 \otimes i_2) \circ (p_1 \otimes p_2) \circ \Delta_B = m_B \circ (\Pi_1 \otimes \Pi_2) \circ \Delta_B = \text{id}_B$  and  $(p_1 \otimes p_2) \circ \Delta_B \circ m_B \circ (i_1 \otimes i_2) = (p_1 \otimes p_2) \circ (\Pi_1 \otimes \Pi_2) \circ \Delta_B \circ m_B \circ (\Pi_1 \otimes \Pi_2) \circ (i_1 \otimes i_2) = (p_1 \circ i_1 \otimes p_2 \circ i_2) = \text{id}_{B_1 \otimes B_2}$ . Hence  $(m_B \circ (i_1 \otimes i_2))^{-1} = (p_1 \otimes p_2) \circ \Delta_B$ . Now we define  $m_1 := p_1 \circ m_B \circ (i_1 \otimes i_1)$ ,  $\eta_1 := p_1 \circ \eta_B$ ,  $\Delta_2 := (p_2 \otimes p_2) \circ \Delta_B \circ i_2$ , and  $\varepsilon_2 := \varepsilon_B \circ i_2$ . Then using (3.1) and the (co-)algebra property of  $B$  one verifies easily that  $(B_1, m_1, \eta_1)$  is an algebra and  $(B_2, \Delta_2, \varepsilon_2)$  is a coalgebra. Furthermore  $i_1$  is an algebra morphism because  $i_1 \circ m_1 = \Pi_1 \circ m_B \circ (i_1 \otimes i_1) = m_B \circ (i_1 \otimes i_1)$ , and  $i_1 \circ \eta_1 = \Pi_1 \circ \eta_B = \eta_B$ . In a  $\pi$ -symmetric manner one proves that  $p_2$  is a coalgebra morphism.

(3)  $\Rightarrow$  (2). Conversely we define  $\Pi_j := i_j \circ p_j$  for  $j \in \{1, 2\}$ . Since by assumption  $i_1$  is an algebra morphism it follows  $\Pi_1 \circ \eta_B = \Pi_1 \circ i_1 \circ \eta_1 = i_1 \circ \eta_1 = \eta_B$  and using  $p_1 \circ i_1 = \text{id}_{B_1}$  it holds  $\Pi_1 \circ m_B \circ (\Pi_1 \otimes \Pi_1) = i_1 \circ p_1 \circ i_1 \circ m_1 \circ (p_1 \otimes p_1) = m_B \circ (\Pi_1 \otimes \Pi_1)$ . In  $\pi$ -symmetrical analogy it will be proven that  $(\Pi_2 \otimes \Pi_2) \circ \Delta_B = (\Pi_2 \otimes \Pi_2) \circ \Delta_B \circ \Pi_2$  and  $\varepsilon_B \circ \Pi_2 = \varepsilon_B$ . From Theorem 3.2.3 we conclude  $(\Pi_1 \otimes \Pi_2) \circ \Delta_B \circ m_B \circ (\Pi_1 \otimes \Pi_2) = (i_1 \otimes i_2) \circ \text{id}_{B_1 \otimes B_2} \circ (p_1 \otimes p_2) = \Pi_1 \otimes \Pi_2$  and  $\text{id}_B = m_B \circ (\Pi_1 \otimes \Pi_2) \circ \Delta_B = m_B \circ (\Pi_1 \otimes \Pi_2) \circ (\Pi_1 \otimes \Pi_2) \circ \Delta_B$ . Thus  $m_B \circ (\Pi_1 \otimes \Pi_2)$  and  $(\Pi_1 \otimes \Pi_2) \circ \Delta_B$  split the idempotent  $(\Pi_1 \otimes \Pi_2)$ .

(3)  $\Rightarrow$  (1). By assumption  $(B_1, m_1, \eta_1)$  is an algebra and  $i_1$  is an algebra morphism,  $i_2$  is a morphism in  $\mathcal{C}$ , and  $m_B \circ (i_1 \otimes i_2)$  is an isomorphism. Define  $\eta_2 := p_2 \circ \eta_B : \mathbb{1} \rightarrow B_2$ . Then  $i_2 \circ \eta_2 = \Pi_2 \circ \eta_B = m_B \circ (\Pi_1 \circ \eta_B \otimes \Pi_2 \circ \eta_B) = m_B \circ (i_1 \otimes i_2) \circ (p_1 \otimes p_2) \circ \Delta_B \circ \eta_B = \eta_B$ . Therefore all conditions of Proposition 2.3.2 are fulfilled implying that  $B$  is algebra isomorphic to a cross product algebra  $B_1 \bowtie_{\varphi_{2,1}}^{\hat{\sigma}} B_2$ . From the proof of Proposition 2.3 one reads off that the isomorphism is given by  $\Lambda = m_B \circ (i_1 \otimes i_2)$ . In a  $\pi$ -symmetric way one shows that  $B$  is coalgebra isomorphic to a cross product coalgebra  $B_1 \bowtie_{\varphi_{1,2}}^{\hat{\rho}} B_2$  on the same tensor product with isomorphism  $\tilde{\Lambda} = (p_1 \otimes p_2) \circ \Delta_B$ . Thus by assumption  $\tilde{\Lambda} = \Lambda^{-1}$ . Since  $B$  is a bialgebra it follows then from Definition 3.1 that  $B_1 \otimes B_2$  is cross product bialgebra  $B_1 \bowtie_{\varphi_{2,1}}^{\hat{\sigma}} B_2$  and  $\Lambda : B_1 \bowtie_{\varphi_{2,1}}^{\hat{\sigma}} B_2 \rightarrow B$  is bialgebra isomorphism. Furthermore the identities  $\text{id}_{\mathbb{1}} = \varepsilon_B \circ \eta_B = \varepsilon_B \circ i_2 \circ \eta_2 = \varepsilon_2 \circ p_2 \circ i_2 \circ \eta_2 = \varepsilon_2 \circ \eta_2$  show that  $B_1 \bowtie_{\varphi_{1,2}}^{\hat{\rho}} B_2$  is normalized.

(1)  $\Rightarrow$  (3). Given a bialgebra isomorphism  $\Lambda : B_1 \bowtie_{\varphi_{2,1}}^{\hat{\rho}} B_2 \rightarrow B$ , then in particular  $\Lambda : B_1 \bowtie_{\varphi_{2,1}}^{\hat{\sigma}} B_2 \rightarrow B$  is an algebra isomorphism and  $\Lambda : B_1 \bowtie_{\varphi_{1,2}}^{\hat{\rho}} B_2 \rightarrow B$  is a coalgebra isomorphism. We define  $i_1 := \Lambda \circ (\text{id}_{B_1} \otimes \eta_2)$ ,  $i_2 := \Lambda \circ (\eta_1 \otimes \text{id}_{B_2})$ ,  $p_1 := (\text{id}_{B_1} \otimes \varepsilon_2) \circ \Lambda^{-1}$ , and  $p_2 := (\varepsilon_1 \otimes \text{id}_{B_2}) \circ \Lambda^{-1}$ . From Propositions 2.3 and 2.9 one derives that  $i_1$  is an algebra morphism,  $p_2$  is a coalgebra morphism, and  $\Lambda = m_B \circ (i_1 \otimes i_2) = ((p_1 \otimes p_2) \circ \Delta_B)^{-1}$ . By assumption  $B_1 \bowtie_{\varphi_{1,2}}^{\hat{\rho}} B_2$  is normalized from which

follows  $p_1 \circ i_1 = (\text{id}_{B_1} \otimes \varepsilon_2) \circ \Lambda^{-1} \circ \Lambda \circ (\text{id}_{B_1} \otimes \eta_2) = \text{id}_{B_1}$  and similarly  $p_2 \circ i_2 = \text{id}_{B_2}$ . ■

The next corollary of Theorem 3.2 will be used frequently in the following.

**COROLLARY 3.3.** *Under the conditions of Theorem 3.2 it holds*

$$\begin{aligned}
 \Pi_2 \circ \eta_B &= \eta_B, & \Pi_1 \circ \Pi_2 &= \eta_B \circ \varepsilon_B, \\
 \Pi_2 \circ m_B &= \Pi_2 \circ m_B \circ (\Pi_2 \otimes \text{id}_B), \\
 \varepsilon_B \circ \Pi_1 &= \varepsilon_B, & \Pi_2 \circ \Pi_1 &= \eta_B \circ \varepsilon_B, \\
 \Delta_B \circ \Pi_1 &= (\text{id}_B \otimes \Pi_1) \circ \Delta_B \circ \Pi_1, \\
 \Pi_1 \circ m_B \circ (\Pi_1 \otimes \text{id}_B) &= \Pi_1 \circ m_B \circ (\Pi_1 \otimes \Pi_1), \\
 (\text{id}_B \otimes \Pi_2) \circ \Delta_B \circ \Pi_2 &= (\Pi_2 \otimes \Pi_2) \circ \Delta_B \circ \Pi_2.
 \end{aligned} \tag{3.2}$$

The structure morphisms  $\varphi_{1,2}$ ,  $\varphi_{2,1}$ ,  $\hat{\rho}$ , and  $\hat{\sigma}$  of the cross product bialgebra  $B_1 \overset{\hat{\rho}}{\bowtie}_{\varphi_{1,2}} \overset{\hat{\sigma}}{\bowtie}_{\varphi_{2,1}} B_2$  can be expressed through the projections and injections on  $B$  as

$$\begin{aligned}
 i_1 \circ \eta_1 &= \eta_B, & \varepsilon_1 \circ p_1 &= \varepsilon_B, \\
 i_2 \circ \eta_2 &= \eta_B, & \varepsilon_2 \circ p_2 &= \varepsilon_B, \\
 m_1 &= p_1 \circ m_B \circ (i_1 \otimes i_1), \\
 \Delta_2 &= (p_2 \otimes p_2) \circ \Delta_B \circ i_2, \\
 \varphi_{1,2} &= (p_2 \otimes p_1) \circ \Delta_B \circ m_B \circ (i_1 \otimes i_2), \\
 \hat{\rho} &= (p_1 \otimes p_1) \circ \Delta_B \circ m_B \circ (i_1 \otimes i_2), \\
 \varphi_{2,1} &= (p_1 \otimes p_2) \circ \Delta_B \circ m_B \circ (i_2 \otimes i_1), \\
 \hat{\sigma} &= (p_1 \otimes p_2) \circ \Delta_B \circ m_B \circ (i_2 \otimes i_2).
 \end{aligned} \tag{3.3}$$

*Proof.* The identities  $i_1 \circ \eta_1 = \eta_B$  and  $\varepsilon_2 \circ p_2 = \varepsilon_B$  hold since  $i_1$  is an algebra morphism and  $p_2$  is a coalgebra morphism, whereas the identities  $i_2 \circ \eta_2 = \eta_B$  and  $\varepsilon_1 \circ p_1 = \varepsilon_B$ , as well as the equations  $\Pi_2 \circ \eta_B = \eta_B$  and  $\varepsilon_B \circ \Pi_1 = \varepsilon_B$ , have been shown in the proof of Theorem 3.2. From the proofs of Propositions 2.3 and 2.9 one can directly read off the structure of the morphisms  $\varphi_{1,2}$ ,  $\varphi_{2,1}$ ,  $\hat{\rho}$ , and  $\hat{\sigma}$  given in (3.3) using  $\Lambda = m_B \circ (i_1 \otimes i_2)$  and  $\Lambda^{-1} = (p_1 \otimes p_2) \circ \Delta_B$ . Since  $i_1$  is an algebra morphism,  $p_2$  is a coalgebra morphism, and  $p_j \circ i_j = \text{id}_{B_j}$  for  $j \in \{1, 2\}$  it follows  $m_1 = p_1 \circ m_B \circ (i_1 \otimes i_1)$  and  $\Delta_2 = (p_2 \otimes p_2) \circ \Delta_B \circ i_2$ . Because of (3.1) and Theorem 3.2.2 it follows  $\Pi_1 \circ \Pi_2 = (\text{id}_B \otimes \varepsilon_B) \circ (\Pi_1 \otimes \Pi_2) \circ \Delta_B \circ m_B \circ (\Pi_1 \otimes \Pi_2) \circ (\eta_B \otimes \text{id}_B) = (\Pi_1 \circ \eta_B \otimes \varepsilon_B \circ \Pi_2) = \eta_B \circ \varepsilon_B$ . Using  $\Pi_2 \circ \eta_B = \eta_B$  and  $\varepsilon_B \circ \Pi_1 = \varepsilon_B$  from above we obtain in a similar way  $\Pi_2 \circ \Pi_1 = \eta_B \circ \varepsilon_B$ . Using consecutively

Theorem 3.2.2 two times, (3.1), the identity  $\Pi_2 = (\varepsilon_B \circ \Pi_1 \otimes \Pi_2) \circ \Delta_B$ , again Theorem 3.2.2, and the identity  $\varepsilon_B \circ \Pi_1 = \varepsilon_B$  one obtains the following series of equations,

$$\begin{aligned} \Pi_2 \circ m_B &= \Pi_2 \circ m_B \circ (m_B \circ (\Pi_1 \otimes \Pi_2) \circ \Delta_B \otimes \text{id}_B) \\ &= \Pi_2 \circ m_B^{(3)} \circ (\Pi_1 \otimes \Pi_1 \otimes \Pi_2) \circ (\text{id}_B \otimes \Delta_B \circ m_B) \\ &\quad \circ (\Pi_1 \otimes \Pi_2 \otimes \text{id}_B) \circ (\Delta_B \otimes \text{id}_B) \\ &= \Pi_2 \circ m_B \circ (\Pi_1 \otimes \Pi_2) \circ (m_B \circ (\Pi_1 \otimes \Pi_1) \otimes \text{id}_B) \\ &\quad \circ (\text{id}_B \otimes \Delta_B \circ m_B) \circ (\text{id}_B \otimes \Pi_2 \otimes \text{id}_B) \circ (\Delta_B \otimes \text{id}_B) \\ &= \Pi_2 \circ m_B \circ (\Pi_2 \otimes \text{id}_B) \end{aligned}$$

and  $\pi$ -symmetrically  $\Delta_B \circ \Pi_1 = (\text{id}_B \otimes \Pi_1) \circ \Delta_B \circ \Pi_1$ . Finally one obtains in a similar manner

$$\begin{aligned} \Pi_1 \circ m_B \circ (\Pi_1 \otimes \text{id}_B) &= \Pi_1 \circ m_B \circ (\Pi_1 \otimes m_B \circ (\Pi_1 \otimes \Pi_2) \circ \Delta_B) \\ &= \Pi_1 \circ m_B^{(3)} \circ (\Pi_1 \otimes \Pi_1 \otimes \Pi_2) \circ (\text{id}_B \otimes \Delta_B) \\ &= \Pi_1 \circ m_B \circ (\Pi_1 \otimes \Pi_2) \circ (m_B \circ (\Pi_1 \otimes \Pi_1) \otimes \Pi_2) \\ &\quad \circ (\text{id}_B \otimes \Delta_B) \\ &= (\Pi_1 \otimes \varepsilon_B \circ \Pi_2) \circ \Delta_B \circ m_B \circ (\Pi_1 \otimes \Pi_2) \\ &\quad \circ (m_B \circ (\Pi_1 \otimes \Pi_1) \otimes \Pi_2) \circ (\text{id}_B \otimes \Delta_B) \\ &= \Pi_1 \circ m_B \circ (\Pi_1 \otimes \Pi_1) \end{aligned}$$

and  $(\text{id}_B \otimes \Pi_2) \circ \Delta_B \circ \Pi_2 = (\Pi_2 \otimes \Pi_2) \circ \Delta_B \circ \Pi_2$  by  $\pi$ -symmetry. ■

*Remark 6.* The statement of Theorem 3.2 can be refined in the following sense. For a given bialgebra  $B$  the tuples  $(B, \Lambda, B_1 \xrightarrow{\hat{\rho}} \hat{\Delta}_{\varphi_{2,1}}^{\hat{\sigma}} B_2)$  and  $(B, i_1, i_2, p_1, p_2)$  obeying the conditions of Theorems 3.2.1 and 3.2.3, respectively, are in one-to-one correspondence. This correspondence has been constructed in the proof of Theorem 3.2.

Theorem 3.2 and the previous remark imply a useful corollary. Given a normalized cross product bialgebra  $B_1 \xrightarrow{\hat{\rho}} \hat{\Delta}_{\varphi_{2,1}}^{\hat{\sigma}} B_2$ , we set  $i_{\alpha 1} := \text{id}_{B_1} \otimes \eta_2$ ,  $i_{\alpha 2} := \eta_1 \otimes \text{id}_{B_2}$ ,  $p_{\alpha 1} := \text{id}_{B_1} \otimes \varepsilon_2$ , and  $p_{\alpha 2} := \varepsilon_1 \otimes \text{id}_{B_2}$ . Then we define

$$\begin{aligned} m_{\triangleright i, jk} &:= p_{\alpha i} \circ m_{B_1 \xrightarrow{\hat{\rho}} \hat{\Delta}_{\varphi_{2,1}}^{\hat{\sigma}} B_2} \circ (i_{\alpha j} \otimes i_{\alpha k}), \\ \Delta_{\triangleright ij, k} &:= (p_{\alpha i} \otimes p_{\alpha j}) \circ \Delta_{B_1 \xrightarrow{\hat{\rho}} \hat{\Delta}_{\varphi_{2,1}}^{\hat{\sigma}} B_2} \circ i_{\alpha k} \end{aligned} \tag{3.4}$$

for  $i, j, k \in \{1, 2\}$ . On the other hand suppose that  $B$  is a bialgebra which obeys the conditions of Theorem 3.2.3. Then we define

$$m_{B i, jk} := p_i \circ m_B \circ (i_j \otimes i_k), \quad \Delta_{B ij, k} := (p_i \otimes p_j) \circ \Delta_B \circ i_k \tag{3.5}$$

for  $i, j, k \in \{1, 2\}$ .



COROLLARY 3.4. *Let  $B$  be bialgebra and suppose that the tuples  $(B, \Lambda, B_1 \xrightarrow{\hat{\rho}}_{\varphi_{1,2}} \xrightarrow{\hat{\sigma}}_{\varphi_{2,1}} B_2)$  and  $(B, i_1, i_2, p_1, p_2)$  are related according to Theorem 3.2. Then  $m_{\triangleright i, jk} = m_{B i, jk}$  and  $\Delta_{\triangleright ij, k} = \Delta_{B ij, k}$ .*

*Proof.* If the conditions of Theorem 3.6 hold, then by construction (see the proof of the theorem) the injections and projections of  $B$  and the morphisms  $i_{\alpha 1}$ ,  $i_{\alpha 2}$ ,  $p_{\alpha 1}$ , and  $p_{\alpha 2}$  are related by  $i_1 := \Lambda \circ i_{\alpha 1}$ ,  $i_2 := \Lambda \circ i_{\alpha 2}$ ,  $p_1 := p_{\alpha 1} \circ \Lambda^{-1}$ , and  $p_2 := p_{\alpha 2} \circ \Lambda^{-1}$ , where  $\Lambda : B_1 \otimes B_2 \rightarrow B$  is the given bialgebra isomorphism. Thus  $m_{\triangleright i, jk} = m_{B i, jk}$  and  $\Delta_{\triangleright ij, k} = \Delta_{B ij, k}$  follow directly. ■

Hence we will use the notation  $m_{i, jk}$  and  $\Delta_{ij, k}$  for the corresponding morphisms henceforth.

### Cocycle Cross Product Bialgebras

Up to now a (co-)modular cocyclic structure of cross product bialgebras and their tensor factors  $B_1$  and  $B_2$  did not emerge. In Definition 3.5 below we will restrict our considerations to cocycle cross product bialgebras for which (co-)modular cocyclic structures appear in a very natural way. The universal property of cocycle cross product bialgebras will be discussed subsequently. We define strong cross product bialgebras in Definition 3.8. They are the basic objects which eventually constitute the universal, (co-)modular cocyclic theory of cross product bialgebras.

In Definition 3.1 the morphisms  $m_1, \eta_1, \varepsilon_1, \Delta_2, \eta_2, \varepsilon_2$ , etc., occur. Definition 3.5 below requires additional morphisms  $\Delta_1, m_2, \mu_l, \mu_r, \nu_l, \nu_r, \sigma$ , and  $\rho$ . This is the stage where we find it convenient to start working with graphical calculus. All  $m, \Delta, \eta, \varepsilon, \mu$ , and  $\nu$  will be presented by the graphics displayed in Fig. 1 respectively.<sup>4</sup> The cocycle and cycle morphisms  $\sigma$  and  $\rho$  will be presented henceforth graphically by  $\sigma = \text{⌣}$ :  $B_2 \otimes B_2 \rightarrow B_1$  and  $\rho = \text{⌢}$ :  $B_2 \rightarrow B_1 \otimes B_1$ .

DEFINITION 3.5. A normalized cross product bialgebra  $B_1 \xrightarrow{\hat{\rho}}_{\varphi_{1,2}} \xrightarrow{\hat{\sigma}}_{\varphi_{2,1}} B_2$  is called a cocycle cross product bialgebra if there exist additional morphisms

$$\begin{aligned} \Delta_1 : B_1 &\rightarrow B_1 \otimes B_1, & m_2 : B_2 \otimes B_2 &\rightarrow B_2, \\ \mu_l : B_2 \otimes B_1 &\rightarrow B_1, & \mu_r : B_2 \otimes B_1 &\rightarrow B_2, \\ \nu_l : B_1 &\rightarrow B_2 \otimes B_1, & \nu_r : B_2 &\rightarrow B_2 \otimes B_1, \\ \sigma : B_2 \otimes B_2 &\rightarrow B_1, & \rho : B_2 &\rightarrow B_1 \otimes B_1 \end{aligned}$$

<sup>4</sup>Note that some of these morphisms might be weak. That is, weak (co-)multiplications, weak (co-)actions, etc.

such that  $\varphi_{1,2}$ ,  $\varphi_{2,1}$ ,  $\hat{\sigma}$ , and  $\hat{\rho}$  are of the form

$$\begin{aligned}\varphi_{1,2} &= (\mathfrak{m}_2 \otimes \mathfrak{m}_1) \circ (\text{id}_{B_1} \otimes \Psi_{B_1, B_2} \otimes \text{id}_{B_2}) \circ (\nu_l \otimes \nu_r), \\ \varphi_{2,1} &= (\mu_l \otimes \mu_r) \circ (\text{id}_{B_2} \otimes \Psi_{B_2, B_1} \otimes \text{id}_{B_1}) \circ (\Delta_2 \otimes \Delta_1), \\ \hat{\sigma} &= (\sigma \otimes \mathfrak{m}_2 \circ (\mu_r \otimes \text{id}_{B_2})) \circ (\text{id}_{B_2} \otimes \Psi_{B_2, B_2} \otimes \text{id}_{B_1 \otimes B_2}) \\ &\quad \circ (\Delta_2 \otimes (\nu_r \otimes \text{id}_{B_2}) \circ \Delta_2), \\ \hat{\rho} &= (\mathfrak{m}_1 \circ (\text{id}_{B_1} \otimes \mu_l) \otimes \mathfrak{m}_1) \circ (\text{id}_{B_1 \otimes B_2} \otimes \Psi_{B_1, B_1} \otimes \text{id}_{B_1}) \\ &\quad \circ ((\text{id}_{B_1} \otimes \nu_l) \circ \Delta_1 \otimes \rho).\end{aligned}$$

Furthermore we require the following (co-)unital identities

$$\begin{aligned}\Delta_1 \circ \eta_1 &= \eta_1 \otimes \eta_2, & (\text{id}_{B_1} \otimes \varepsilon_1) \circ \Delta_1 &= (\varepsilon_1 \otimes \text{id}_{B_1}) \circ \Delta_1 = \text{id}_{B_1}, \\ \varepsilon_2 \circ \mathfrak{m}_2 &= \varepsilon_2 \otimes \varepsilon_2, & \mathfrak{m}_2 \circ (\text{id}_{B_2} \otimes \eta_2) &= \mathfrak{m}_2 \circ (\eta_2 \otimes \text{id}_{B_2}) = \text{id}_{B_2}, \\ \mu_l \circ (\eta_2 \otimes \text{id}_{B_1}) &= \text{id}_{B_1}, & \mu_l \circ (\text{id}_{B_2} \otimes \eta_1) &= \eta_1 \circ \varepsilon_2, \\ \varepsilon_1 \circ \mu_l &= \varepsilon_2 \otimes \varepsilon_1, & \mu_r \circ (\text{id}_{B_2} \otimes \eta_1) &= \text{id}_{B_2}, \\ \mu_r \circ (\eta_2 \otimes \text{id}_{B_1}) &= \eta_2 \circ \varepsilon_1, & \varepsilon_2 \circ \mu_r &= \varepsilon_2 \otimes \varepsilon_1, \\ (\varepsilon_2 \otimes \text{id}_{B_1}) \circ \nu_l &= \text{id}_{B_1}, & (\text{id}_{B_2} \otimes \varepsilon_1) \circ \nu_l &= \eta_2 \circ \varepsilon_1, \\ \nu_l \circ \eta_1 &= \eta_2 \otimes \eta_1, & (\text{id}_{B_2} \otimes \varepsilon_1) \circ \nu_r &= \text{id}_{B_2}, \\ (\varepsilon_2 \otimes \text{id}_{B_1}) \circ \nu_r &= \eta_1 \circ \varepsilon_2, & \nu_r \circ \eta_2 &= \eta_2 \otimes \eta_1\end{aligned}\tag{3.6}$$

and the “projection” relations

$$\begin{aligned}(\mathfrak{m}_2 \otimes \text{id}_{B_1}) \circ (\text{id}_{B_2} \otimes \nu_r) &= (\mathfrak{m}_2 \otimes \text{id}_{B_1}) \circ (\mu_r \otimes \varphi_{1,2}) \\ &\quad \circ (\text{id}_{B_2} \otimes (\rho \otimes \text{id}_{B_2}) \circ \Delta_2), \\ (\mu_l \otimes \text{id}_{B_1}) \circ (\text{id}_{B_2} \otimes \Delta_1) &= (\mathfrak{m}_1 \circ (\text{id}_{B_1} \otimes \sigma) \otimes \text{id}_{B_1}) \\ &\quad \circ (\varphi_{2,1} \otimes \nu_l) \circ (\text{id}_{B_2} \otimes \Delta_1).\end{aligned}\tag{3.7}$$

Cocycle cross product bialgebras will be denoted subsequently by  $B_1 \overset{\hat{\rho}}{\underset{\hat{\sigma}}{\varphi_{1,2} \bowtie \varphi_{2,1}}} B_2$ .

*Remark 7.* For a cocycle cross product bialgebra the following (co-)unital identities can be derived easily,

$$\begin{aligned}\Delta_2 \circ \eta_2 &= \eta_2 \otimes \eta_2, & \varepsilon_1 \circ \mathfrak{m}_1 &= \varepsilon_1 \otimes \varepsilon_1, \\ \varepsilon_1 \circ \sigma &= \varepsilon_2 \otimes \varepsilon_2, & \rho \circ \eta_2 &= \eta_1 \otimes \eta_1, \\ \sigma \circ (\eta_2 \otimes \text{id}_{B_2}) &= \sigma \circ (\text{id}_{B_2} \otimes \eta_2) = \eta_1 \circ \varepsilon_2, \\ (\text{id}_{B_1} \otimes \varepsilon_1) \circ \rho &= (\varepsilon_1 \otimes \text{id}_{B_1}) \circ \rho = \eta_1 \circ \varepsilon_2.\end{aligned}$$

*Remark 8.* By definition, cocycle cross product bialgebras always come with certain structure morphisms  $m_1, m_2, \Delta_1, \Delta_2$ , etc. There might be two different cocycle cross product bialgebras with the same underlying bialgebra structure. It is understood henceforth, that the notation  $B_1 \overset{\hat{\rho}}{\varphi_{1,2}} \overset{\hat{c}}{\bowtie} \overset{\hat{\sigma}}{\varphi_{2,1}} B_2$  always refers to the complete structure of cocycle cross product bialgebras.

The graphics of the morphisms  $\varphi_{1,2}, \varphi_{2,1}, \hat{\rho}$ , and  $\hat{\sigma}$  of a cocycle cross product bialgebra  $B_1 \overset{\hat{\rho}}{\varphi_{1,2}} \overset{\hat{c}}{\bowtie} \overset{\hat{\sigma}}{\varphi_{2,1}} B_1$  are given by

$$\varphi_{1,2} := \text{[diagram]}, \quad \varphi_{2,1} := \text{[diagram]}, \quad \hat{\rho} := \text{[diagram]}, \quad \hat{\sigma} := \text{[diagram]} \quad (3.8)$$

Then the graphical shapes of the multiplication and the comultiplication look like

$$m_{B_1 \overset{\hat{\rho}}{\varphi_{1,2}} \overset{\hat{c}}{\bowtie} \overset{\hat{\sigma}}{\varphi_{2,1}} B_1} = \text{[diagram]} \quad \text{and} \quad \Delta_{B_1 \overset{\hat{\rho}}{\varphi_{1,2}} \overset{\hat{c}}{\bowtie} \overset{\hat{\sigma}}{\varphi_{2,1}} B_1} = \text{[diagram]} \quad (3.9)$$

It is an easy exercise to prove that Definition 3.5 is compatible with trivial (co-)actions  $\mu_l, \mu_r, \nu_l, \nu_r$  and trivial (co-)cycles  $\sigma$  and  $\rho$ , respectively, in the sense that no additional identities involving (co-)units have to be required for the remaining morphisms which define this special cocycle cross product bialgebra.

The following theorem is the central basic statement in Section 3. It describes universality of cocycle cross product bialgebras.

**THEOREM 3.6.** *Let  $B$  be a bialgebra in  $\mathcal{C}$ . Then the following statements are equivalent.*

(1)  *$B$  is a bialgebra isomorphic to a cocycle cross product bialgebra  $B_1 \overset{\hat{\rho}}{\varphi_{1,2}} \overset{\hat{c}}{\bowtie} \overset{\hat{\sigma}}{\varphi_{2,1}} B_2$ .*

(2) *There are idempotents  $\Pi_1, \Pi_2 \in \text{End}(B)$  such that the conditions of Theorem 3.2.2 and the following “projection” relations hold,*

$$\begin{aligned} (\gamma_1) \quad & (\text{id} \otimes \Pi_1) \circ \Delta_B = \delta_{(1,2,1)} \circ \gamma_1 \circ (\Pi_1 \otimes \Pi_2) \circ \Delta_B, \\ (\gamma_2) \quad & m_B \circ (\Pi_2 \otimes \text{id}) = m_B \circ (\Pi_1 \otimes \Pi_2) \circ \gamma_2 \circ \delta_{(2,1,2)}, \\ (\delta_j) \quad & (\Pi_j \otimes \text{id}) \circ \delta_{(0,0,0)} \circ (\text{id} \otimes \Pi_j) = (\Pi_j \otimes \text{id}) \circ \delta_{(0,j,0)} \circ (\text{id} \otimes \Pi_j) \end{aligned} \quad (3.10)$$

for  $j \in \{1, 2\}$ . In (3.10) we used the abbreviations

$$\gamma_j := (m_B \otimes m_B) \circ (\text{id} \otimes \Pi_j \otimes \text{id} \otimes \text{id}) \circ (\text{id} \otimes \Psi_{B,B} \otimes \text{id}) \circ (\Delta_B \otimes \Delta_B),$$

$$\delta_{(i,j,k)} := (m_B \otimes \text{id}) \circ (\Pi_i \otimes \Pi_j \otimes \Pi_k) \circ (\text{id} \otimes \Delta_B),$$

for  $i, j, k \in \{0, 1, 2\}$ , and we set  $\Pi_0 := \text{id}_A$ .

(3) There are objects  $B_1$  and  $B_2$  and morphisms  $B_1 \xrightarrow{i_1} B \xrightarrow{p_1} B_1$  and  $B_2 \xrightarrow{i_2} B \xrightarrow{p_2} B_2$  for which the conditions of Theorem 3.2.3 and the “projection” relations (3.10) hold, with  $\Pi_j := i_j \circ p_j$ ,  $j \in \{1, 2\}$ .

*Proof.* Obviously statements (2) and (3) are equivalent due to Theorem 3.2. Hence suppose statements (2) and (3) hold. Then by Theorem 3.2 there exists a normalized cross product bialgebra  $B_1 \hat{\rho}_{\varphi_{1,2}} \hat{\sigma}_{\varphi_{2,1}} B_2$  which is isomorphic to  $B$  via the isomorphism  $\Lambda = m_B \circ (i_1 \otimes i_2)$ . We define

$$\begin{aligned} m_2 &:= p_2 \circ m_B \circ (i_2 \otimes i_2), \\ \Delta_1 &:= (p_1 \otimes p_1) \circ \Delta_B \circ i_1, \\ \sigma &:= p_1 \circ m_B \circ (i_2 \otimes i_2), \\ \rho &:= (p_1 \otimes p_1) \circ \Delta_B \circ i_2, \\ \mu_l &:= p_1 \circ m_B \circ (i_2 \otimes i_1), \\ \nu_l &:= (p_2 \otimes p_1) \circ \Delta_B \circ i_1, \\ \mu_r &:= p_2 \circ m_B \circ (i_2 \otimes i_1), \\ \nu_r &:= (p_2 \otimes p_1) \circ \Delta_B \circ i_2. \end{aligned} \tag{3.11}$$

The morphisms  $m_1$ ,  $\Delta_2$ ,  $\eta_1$ ,  $\eta_2$ ,  $\varepsilon_1$ , and  $\varepsilon_2$  are given in terms of the projections and injections by the corresponding relations in (3.3) in Corollary 3.3. With the help of these data we define structure morphisms  $\tilde{\varphi}_{1,2}$ ,  $\tilde{\varphi}_{2,1}$ ,  $\hat{\sigma}$ , and  $\hat{\rho}$  analogous to (3.8). We will show that the morphisms  $m_{B_1 \otimes B_2}$  and  $\Delta_{B_1 \otimes B_2}$  defined with these structure morphisms according to (3.9) precisely coincide with  $m_{B_1 \hat{\rho}_{\varphi_{1,2}} \hat{\sigma}_{\varphi_{2,1}} B_2}$  and  $\Delta_{B_1 \hat{\rho}_{\varphi_{1,2}} \hat{\sigma}_{\varphi_{2,1}} B_2}$ , respectively, if the assumptions of statements (2) (or (3)) are satisfied. Before we prove this we will provide several auxiliary identities. From (3.1) and Corollary (3.3) we obtain

$$\begin{aligned} &(\Pi_2 \otimes \Pi_2) \circ \Delta_B \circ m_B \circ (\Pi_2 \otimes \text{id}_B) \\ &= (\Pi_2 \otimes \Pi_2) \circ \Delta_B \circ \Pi_2 \circ m_B \circ (\Pi_2 \otimes \text{id}_B) \\ &= (\Pi_2 \otimes \Pi_2) \circ \Delta_B \circ m_B, \end{aligned} \tag{3.12}$$

$$\begin{aligned} &\Pi_1 \circ m_B^{(3)} \circ (\Pi_1 \otimes \Pi_1 \otimes \Pi_1) \\ &= \Pi_1 \circ m_B \circ (\text{id}_B \otimes \Pi_1 \circ m_B) \circ (\Pi_1 \otimes \Pi_1 \otimes \Pi_1) \\ &= \Pi_1 \circ m_B \circ (\text{id}_B \otimes \Pi_1 \circ m_B) \circ (\Pi_1 \otimes \Pi_1 \otimes \text{id}_B) \\ &= \Pi_1 \circ m_B^{(3)} \circ (\Pi_1 \otimes \Pi_1 \otimes \text{id}_B). \end{aligned} \tag{3.13}$$

Furthermore it holds

$$(\Pi_1 \otimes \text{id}_B) \circ \delta_{(1,0,2)} = (\Pi_1 \otimes \Pi_2) \circ \Delta_B \circ m_B \circ (\Pi_1 \otimes \text{id}_B) \tag{3.14}$$

since the following equations are satisfied,

$$\begin{aligned}
 & m_B \circ (\Pi_1 \otimes \Pi_2) \circ (m_B \otimes \text{id}_B) \circ (\Pi_1 \otimes \Delta_B) \\
 &= m_B \circ (\Pi_1 \otimes \text{id}_B) \circ (m_B \circ (\Pi_1 \otimes \Pi_1) \otimes \Pi_2) \circ (\text{id}_B \otimes \Delta_B) \\
 &= m_B \circ (\Pi_1 \otimes m_B \circ (\Pi_1 \otimes \Pi_2) \circ \Delta_B) \\
 &= m_B \circ (\Pi_1 \otimes \text{id}_B).
 \end{aligned}$$

Then (3.14) follows from Theorem 3.2.3. Observe that Corollary 3.3 implies the additional conditions (3.10) have not been used to derive (3.14). Subsequently we will prove  $m_{B_1 \otimes B_2} = m_{B_1 \varphi_{1,2} \hat{\rho} \hat{\sigma} \varphi_{2,1} B_2}$  graphically. Henceforth we use the notation  $\Pi_j = \begin{array}{c} | \\ \circlearrowleft \\ | \end{array}$  for  $j \in \{1, 2\}$ .

$$\begin{aligned}
 m_{B_1 \otimes B_2} &= \text{Diagram 1} = \text{Diagram 2} = \text{Diagram 3} \\
 &= \text{Diagram 4} = \text{Diagram 5} = (p_1 \otimes p_2) \circ \Delta_B \circ m_B^{(4)} \circ (i_1 \otimes i_2 \otimes i_1 \otimes i_2) \\
 &= \Lambda^{-1} \circ m_B \circ (\Lambda \otimes \Lambda) = m_{B_1 \varphi_{1,2} \hat{\rho} \hat{\sigma} \varphi_{2,1} B_2}.
 \end{aligned}
 \tag{3.15}$$

To derive the first identity of (3.15) we used the specific form of the structure morphisms  $\tilde{\varphi}_{1,2}$ ,  $\tilde{\varphi}_{2,1}$ ,  $\hat{\sigma}$ , and  $\hat{\rho}$ . Then (3.1), (3.2), and the third identity of (3.10) for  $j = 1$  yield the second equality of (3.15). With Theorem 3.2.2, (3.2), and (3.12) we derive the third equation, whereas (3.13) and again use of Theorem 3.2.2 yield the fourth identity of (3.15). The fifth equality comes from application of the second “projection” relation of (3.10), and for the derivation of the sixth identity we use (3.14). Finally the definition of  $\Lambda$ , given in the proof of Theorem 3.2, yields the result. In a  $\pi$ -symmetric way the identity  $\Delta_{B_1 \otimes B_2} = \Delta_{B_1 \varphi_{1,2} \hat{\rho} \hat{\sigma} \varphi_{2,1} B_2}$  will be shown. The (co-)unital identities (3.6) can be verified straightforwardly from the definitions, the assumptions, and Corollary 3.3. It remains to prove the “projection” relations (3.7).

Observe that

$$\begin{aligned}\Pi_1 &= \Lambda \circ (\text{id}_{B_1} \otimes \eta_2 \circ \varepsilon_2) \circ \Lambda^{-1}, \\ \Pi_2 &= \Lambda \circ (\eta_1 \circ \varepsilon_1 \otimes \text{id}_{B_2}) \circ \Lambda^{-1}.\end{aligned}\tag{3.16}$$

Taking into account the relation  $\Delta_B = (\Lambda \otimes \Lambda) \circ \Delta_{B_1 \varphi_{1,2} \hat{\rho} \hat{\rho} \hat{\sigma} \hat{\sigma} \varphi_{2,1} B_2} \circ \Lambda^{-1}$  and the relation  $\mathfrak{m}_B = \Lambda \circ \mathfrak{m}_{B_1 \varphi_{1,2} \hat{\rho} \hat{\rho} \hat{\sigma} \hat{\sigma} \varphi_{2,1} B_2} \circ (\Lambda^{-1} \otimes \Lambda^{-1})$  one obtains with the help of (3.16) and (3.6)

$$\Delta_B \circ \Pi_1 = (\Lambda \otimes \Lambda \circ (\text{id}_{B_1} \otimes \eta_2)) \circ (\text{id}_{B_1} \otimes \nu_l) \circ \Delta_1 \circ (\text{id}_{B_1} \otimes \varepsilon_2) \circ \Lambda,\tag{3.17}$$

$$\Pi_1 \circ \mathfrak{m}_B = \Lambda \circ (\text{id} \otimes \eta_2) \circ \mathfrak{m}_1 \circ (\mathfrak{m}_1 \otimes \sigma) \circ (\text{id} \otimes \varphi_{2,1} \otimes \text{id}) \circ (\Lambda^{-1} \otimes \Lambda^{-1}).$$

Gluing the identities of (3.17) and  $\Pi_1$  according to the left and right hand side of the third equation of (3.10) (for  $j = 1$ ), using (3.16) again, and eventually multiplying both resulting sides with  $|\circ (\Lambda \otimes \Lambda) \circ (\eta_1 \otimes \text{id} \otimes \text{id} \otimes \eta_2)$  and  $(\text{id} \otimes \varepsilon_2 \otimes \text{id} \otimes \varepsilon_2) \circ (\Lambda^{-1} \otimes \Lambda^{-1}) \circ |$  yields  $(\mu_l \otimes \text{id}_{B_1}) \circ (\text{id}_{B_2} \otimes \Delta_1) = (\mathfrak{m}_1 \circ (\text{id}_{B_1} \otimes \sigma) \otimes \text{id}_{B_1}) \circ (\varphi_{2,1} \otimes \nu_l) \circ (\text{id}_{B_2} \otimes \Delta_1)$  which is the second identity of (3.7). Analogously the first equation of (3.7) can be derived. This proves that  $B_1 \varphi_{1,2} \hat{\rho} \hat{\rho} \hat{\sigma} \hat{\sigma} \varphi_{2,1} B_2$  is a cocycle cross product bialgebra.

Conversely suppose that  $\Lambda : B_1 \varphi_{1,2} \hat{\rho} \hat{\rho} \hat{\sigma} \hat{\sigma} \varphi_{2,1} B_2 \rightarrow B$  is an isomorphism of bialgebras. To prove statement (2) it suffices to verify relations (3.10). Like in the proof (1)  $\Rightarrow$  (3) of Theorem 3.2 we define  $i_1 := \Lambda \circ (\text{id}_{B_1} \otimes \eta_2)$ ,  $i_2 := \Lambda \circ (\eta_1 \otimes \text{id}_{B_2})$ ,  $p_1 := (\text{id}_{B_1} \otimes \varepsilon_2) \circ \Lambda^{-1}$ , and  $p_2 := (\varepsilon_1 \otimes \text{id}_{B_2}) \circ \Lambda^{-1}$ . Then the identities (3.17) will be proven for  $\Pi_j := i_j \circ p_j$  in the way described above. The previously performed gluing of the identities (3.17) yields

$$\begin{aligned}(\Pi_1 \otimes \text{id}) \circ \delta_{(0,0,0)} \circ (\text{id} \otimes \Pi_1) \\ = (\Lambda \circ (\text{id} \otimes \eta_2) \otimes \Lambda \circ (\text{id} \otimes \eta_2)) \circ (\mathfrak{m}_1 \circ (\mathfrak{m}_1 \otimes \sigma) \otimes \text{id}) \\ \circ (\text{id} \otimes \varphi_{2,1} \otimes \nu_l) \circ (\Lambda^{-1} \otimes \Delta_1 \circ (\text{id} \otimes \varepsilon_2) \circ \Lambda^{-1}),\end{aligned}$$

$$\begin{aligned}(\Pi_1 \otimes \text{id}) \circ \delta_{(0,1,0)} \circ (\text{id} \otimes \Pi_1) \\ = (\Lambda \circ (\text{id} \otimes \eta_2) \otimes \Lambda \circ (\text{id} \otimes \eta_2)) \circ (\mathfrak{m}_1 \circ (\text{id} \otimes \mu_l) \otimes \text{id}) \\ \circ (\Lambda^{-1} \otimes \Delta_1 \circ (\text{id} \otimes \varepsilon_2) \circ \Lambda^{-1}).\end{aligned}$$

Therefore by assumption (3.7) the third identity of (3.10) for  $j = 1$  follows. Applying  $\pi$ -symmetry the third equation of (3.10) for  $j = 2$  will be derived. Then all conditions are satisfied which have been needed to derive the first four identities in (3.15). Hence

$$\begin{aligned}\mathfrak{m}_{B_1 \varphi_{1,2} \hat{\rho} \hat{\rho} \hat{\sigma} \hat{\sigma} \varphi_{2,1} B_2} = (p_1 \circ \mathfrak{m}_B^{(3)} \otimes p_1 \circ \mathfrak{m}_B) \circ (\text{id}^{(2)} \otimes \Psi_{B,B} \circ (\text{id} \otimes \Pi_2) \otimes \text{id}) \\ \circ (i_1 \otimes \Delta_B \circ \mathfrak{m}_B \circ (i_2 \otimes i_1) \otimes \Delta_B \circ i_2).\end{aligned}$$

On the other hand it holds by assumption  $m_{B_1 \varphi_{1,2} \hat{\rho} \hat{c} \hat{\sigma} \varphi_{2,1} B_2} = \Lambda^{-1} \circ m_B \circ (\Lambda \otimes \Lambda) = (p_1 \otimes p_2) \circ \Delta_B \circ m_B^{(4)} \circ (i_1 \otimes i_2 \otimes i_1 \otimes i_2) = (p_1 \otimes p_2) \circ \delta_{(0,0,0)} \circ (i_1 \otimes m_B^{(3)} \circ (i_2 \otimes i_1 \otimes i_2))$ , where we used (3.14) which has been derived under the more general assumption of Theorem 3.2. Multiplying both expressions of  $m_{B_1 \varphi_{1,2} \hat{\rho} \hat{c} \hat{\sigma} \varphi_{2,1} B_2}$  with  $|\circ (\eta_1 \otimes p_2 \otimes p_1 \otimes p_2)$  and  $(i_1 \otimes i_2) \circ |$ , and using that  $i_1$  is an algebra morphism yields

$$\begin{aligned} & (\Pi_1 \circ m_B \otimes \Pi_1 \circ m_B) \circ (\text{id} \otimes \Psi_{B,B} \circ (\text{id} \otimes \Pi_2) \otimes \text{id}) \\ & \circ (\Delta_B \circ m_B \circ (\Pi_2 \otimes \Pi_1) \otimes \Delta_B \circ \Pi_2) \\ & = (\Pi_1 \otimes \Pi_1) \circ \Delta_B \circ m_B^{(3)} \circ (\Pi_2 \otimes \Pi_1 \otimes \Pi_2) \end{aligned}$$

from which the second identity of (3.10) can be derived easily with the help of Theorem 3.2.2. Similarly by  $\pi$ -symmetry the first equation of (3.10) will be proven. ■

*Remark 9.* The “projection” relations  $(\gamma_1)$  and  $(\gamma_2)$  in (3.10) can be derived from the identities

$$(\beta_1): \beta_1 = \beta_1 \circ (\text{id} \otimes \Pi_1) \quad \text{and} \quad (\beta_2): \beta_2 = (\Pi_2 \otimes \text{id}) \circ \beta_2, \quad (3.18)$$

where  $\beta_1 := (\Pi_1 \circ m_B \otimes \text{id}) \circ (\text{id} \otimes \Psi_{B,B}) \circ (\Delta_B \circ \Pi_1 \otimes \text{id})$  and  $\beta_2 := (\text{id} \otimes \Pi_2 \circ m_B) \circ (\Psi_{B,B} \otimes \text{id}) \circ (\text{id} \otimes \Delta_B \circ \Pi_2)$ . However, in general the conditions  $(\beta_1)$  and  $(\beta_2)$  are not equivalent to the conditions  $(\gamma_1)$  and  $(\gamma_2)$  in Theorem 3.6.

**PROPOSITION 3.7.** *Under the equivalent conditions of Theorem 3.6 the following statements hold.*

- (1)  $\mu_l = \varepsilon_2 \otimes \text{id}_{B_1}$  is trivial  $\Leftrightarrow \Pi_1 \circ m_B \circ (\text{id}_B \otimes \Pi_1) = \Pi_1 \circ m_B \circ (\Pi_1 \otimes \Pi_1)$ .
- (2)  $\mu_r = \text{id}_{B_2} \otimes \varepsilon_1$  is trivial  $\Leftrightarrow \Pi_2 \circ m_B = \Pi_2 \circ m_B \circ (\Pi_2 \otimes \Pi_2) \Leftrightarrow p_2$  is algebra morphism.
- (3)  $\nu_l = \eta_2 \otimes \text{id}_{B_1}$  is trivial  $\Leftrightarrow \Delta_B \circ \Pi_1 = (\Pi_1 \otimes \Pi_1) \circ \Delta_B \circ \Pi_1 \Leftrightarrow i_1$  is coalgebra morphism.
- (4)  $\nu_r = \text{id}_{B_2} \otimes \eta_1$  is trivial  $\Leftrightarrow (\Pi_2 \otimes \text{id}_B) \circ \Delta_B \circ \Pi_2 = (\Pi_2 \otimes \Pi_2) \circ \Delta_B \circ \Pi_2$ .
- (5)  $\sigma = \eta_1 \circ (\varepsilon_2 \otimes \varepsilon_2)$  is trivial  $\Leftrightarrow \hat{\sigma} = \eta_1 \otimes m_2 \Leftrightarrow m_B \circ (\Pi_2 \otimes \Pi_2) = \Pi_2 \circ m_B \circ (\Pi_2 \otimes \Pi_2) \Leftrightarrow i_2$  is algebra morphism.
- (6)  $\rho = (\eta_1 \otimes \eta_1) \circ \varepsilon_2$  is trivial  $\Leftrightarrow \hat{\rho} = \Delta_1 \otimes \varepsilon_2 \Leftrightarrow (\Pi_1 \otimes \Pi_1) \circ \Delta_B = (\Pi_1 \otimes \Pi_1) \circ \Delta_B \circ \Pi_1 \Leftrightarrow p_1$  is coalgebra morphism.

(7)  $\mu_l$  and  $\sigma$  are trivial  $\Leftrightarrow \Pi_1 \circ m_B = \Pi_1 \circ m_B \circ (\Pi_1 \otimes \Pi_1) \Leftrightarrow p_1$  is algebra morphism.

(8)  $\nu_r$  and  $\rho$  are trivial  $\Leftrightarrow \Delta_B \circ \Pi_2 = (\Pi_2 \otimes \Pi_2) \circ \Delta_B \circ \Pi_2 \Leftrightarrow i_2$  is coalgebra morphism.

*Proof.* We prove Propositions 3.7.1 and 3.7.5. The remaining statements can be derived in a similar manner or follow directly by  $\pi$ -symmetric reasoning. Without loss of generality we may assume  $\Pi_1 = \text{id}_{B_1} \otimes \eta_2 \circ \varepsilon_2$  and  $\Pi_2 = \eta_1 \circ \varepsilon_1 \otimes \text{id}_{B_2}$ .

Ad (1). Suppose that  $\mu_l$  is trivial. This means that  $(\text{id}_{B_1} \otimes \varepsilon_2) \circ \varphi_{2,1} = \varepsilon_2 \otimes \text{id}_{B_1}$ . Using (2.2) and the unital identities of (2.3) then yields  $\Pi_1 \circ m_B \circ (\text{id}_B \otimes \Pi_1) = (m_{B_1} \otimes \eta_2 \circ \varepsilon_2) \circ (\text{id}_{B_1} \otimes \varphi_{2,1} \otimes \varepsilon_2) = (m_{B_1} \otimes \eta_2) \circ (\text{id}_{B_1} \otimes \mu_l \otimes \varepsilon_2) = (m_{B_1} \otimes \eta_2) \circ (\text{id}_{B_1} \otimes \varepsilon_2 \otimes \text{id}_{B_1} \otimes \varepsilon_2)$ . On the other hand from the unital identities of (2.3) immediately follows  $\Pi_1 \circ m_B \circ (\Pi_1 \otimes \Pi_1) = (m_{B_1} \otimes \eta_2) \circ (\text{id}_{B_1} \otimes \varepsilon_2 \otimes \text{id}_{B_1} \otimes \varepsilon_2)$ . Conversely if  $\Pi_1 \circ m_B \circ (\text{id}_B \otimes \Pi_1) = \Pi_1 \circ m_B \circ (\Pi_1 \otimes \Pi_1)$  holds then analogous calculations as before yield  $(m_{B_1} \otimes \eta_2 \circ \varepsilon_2) \circ (\text{id}_{B_1} \otimes \varphi_{2,1} \otimes \varepsilon_2) = (m_{B_1} \otimes \eta_2) \circ (\text{id}_{B_1} \otimes \varepsilon_2 \otimes \text{id}_{B_1} \otimes \varepsilon_2)$ . Then the triviality of  $\mu_l = (\text{id}_{B_1} \otimes \varepsilon_2) \circ \varphi_{2,1}$  follows straightforwardly.

Ad (5). Suppose that  $m_B \circ (\Pi_2 \otimes \Pi_2) = \Pi_2 \circ m_B \circ (\Pi_2 \otimes \Pi_2)$ . Then  $m_2 = p_2 \circ m_B \circ (i_2 \otimes i_2)$  is associative as  $m_2 \circ (\text{id} \otimes m_2) = p_2 \circ m_B \circ (i_2 \otimes \Pi_2 \circ m_B \circ (i_2 \otimes i_2)) = p_2 \circ m_B \circ (\text{id}_B \otimes m_B) \circ (i_2 \otimes i_2 \otimes i_2) = p_2 \circ m_B \circ (m_B \otimes \text{id}_B) \circ (i_2 \otimes i_2 \otimes i_2) = m_2 \circ (m_2 \otimes \text{id}_{B_2})$ . Hence  $B_2$  is an algebra, and  $i_2 \circ m_2 = \Pi_2 \circ m_B \circ (i_2 \otimes i_2) = m_B \circ (i_2 \otimes i_2)$ . Therefore  $i_2$  is algebra morphism. Conversely, if  $i_2$  is algebra morphism then  $m_B \circ (\Pi_2 \otimes \Pi_2) = i_2 \circ m_2 \circ (p_2 \otimes p_2) = i_2 \circ p_2 \circ i_2 \circ m_2 \circ (p_2 \otimes p_2) = \Pi_2 \circ m_B \circ (\Pi_2 \otimes \Pi_2)$ .

Let  $i_2$  be algebra morphism. Then from the last identity of (3.3) and the second identity of (3.2) we derive  $\hat{\sigma} = (p_1 \otimes p_2) \circ \Delta_B \circ m_B \circ (i_2 \otimes i_2) = (p_1 \otimes p_2) \circ \Delta_B \circ i_2 \circ m_2 = \eta_1 \otimes m_2$ . If on the other hand  $\hat{\sigma} = \eta_1 \otimes m_2$  then we use (2.2) and (2.3) to obtain  $m_B \circ (i_2 \otimes i_2) = m_B \circ (\eta_1 \otimes \text{id}_{B_2} \otimes \eta_1 \otimes \text{id}_{B_2}) = (\eta_1 \otimes \text{id}_{B_2}) \circ m_2 = i_2 \circ m_2$  which shows that  $i_2$  is algebra morphism.

It is an easy exercise to prove that triviality of  $\hat{\sigma}$  and triviality of  $\sigma$  are equivalent. ■

*Remark 10.* Under the equivalent conditions of Theorem 3.2 similar results like in Proposition 3.7 can be shown for general cross product bialgebras if  $m_2$ ,  $\Delta_1$ ,  $\mu_l$ ,  $\mu_r$ ,  $\nu_l$ , and  $\nu_r$  will be defined formally as in (3.11).

### Strong Cross Product Bialgebras

In the following we define strong cross product bialgebras. They will be studied in more detail in Theorems 4.4 and 4.5 in connection with so-called strong Hopf data. It turns out that strong cross product bialgebras



are the central objects in our universal, (co-)modular cocyclic theory of cross product bialgebras.<sup>5</sup>

DEFINITION 3.8. A cocycle cross product bialgebra  $B_1 \overset{\hat{\rho}}{\underset{\varphi_{1,2}}{\bowtie}} \overset{\hat{\sigma}}{\underset{\varphi_{2,1}}{\bowtie}} B_2$  is called a strong cross product bialgebra if in addition the identities

$$\text{Diagram 1} = \text{Diagram 2}, \quad \text{Diagram 3} = \text{Diagram 4} \tag{3.19}$$

$$\text{Diagram 5} = \text{Diagram 6}, \quad \text{Diagram 7} = \text{Diagram 8}, \quad \text{Diagram 9} = \text{Diagram 10}, \quad \text{Diagram 11} = \text{Diagram 12} \tag{3.20}$$

$$\text{Diagram 13} = \text{Diagram 14}, \quad \text{Diagram 15} = \text{Diagram 16} \tag{3.21}$$

are fulfilled. We denote strong cross product bialgebras by<sup>6</sup>  $B_1 \overset{\hat{\rho}}{\underset{\varphi_{1,2}}{\bowtie}} \overset{\hat{\sigma}}{\underset{\varphi_{2,1}}{\bowtie}} B_2$ .

Remark 11 (!). A tedious calculation shows that the “projection” relations  $(\gamma_1)$ ,  $(\gamma_2)$ ,  $(\delta_1)$ , and  $(\delta_2)$  in (3.10) as well as (3.7) are redundant for strong cross product bialgebras. Therefore, if we use the morphisms  $m_{i,jk}$  and  $\Delta_{ij,k}$  from Corollary 3.4 an alternative definition of strong cross product bialgebras can be given as follows.

A strong cross product bialgebra is a cross product bialgebra for which the identities (3.19), (3.20), and (3.21) formally hold for the corresponding morphisms  $m_{i,jk}$  and  $\Delta_{ij,k}$ .

We call a strong cross product bialgebra regular if all defining identities have rank (2, 2), (1, 3), or (3, 1). We call it pure if (3.19), (3.20), and (3.21) are redundant.

Any bialgebra  $B$  which is isomorphic to a certain cocycle cross product bialgebra has injections and projections  $i_1, i_2, p_1,$  and  $p_2$  which are uniquely determined by the cocycle cross product bialgebra and the given isomorphism (see Theorem 3.6 and Remark 6). In the special case of strong cross product bialgebras the structure morphisms obey the additional identities (3.19)–(3.21). Using (3.3) and (3.11) these relations can be translated easily

<sup>5</sup>Strong cross product bialgebras and strong Hopf data provide a unifying universal and (co-)modular cocyclic theory of cross product bialgebras. But they are probably not the most general setting to meet the same demands. Therefore our notation “strong” should be specified further. However, in order to avoid terminological blow-up we will henceforth use our notation, always having in mind that there might be a weaker definition of “strong.” This is certainly an interesting direction for further study.

<sup>6</sup>The deeper meaning of this notation will become clear in Section 4.

into equations of the idempotents  $\Pi_1$  and  $\Pi_2$  of the bialgebra  $B$  as

$$\begin{aligned}
& (\Pi_2 \otimes \text{id}_B) \circ \Phi_{\text{id}_B} \circ (\Pi_1 \otimes \Pi_1) = (\Pi_2 \otimes \text{id}_B) \circ \Delta_B \circ \Pi_1 \otimes \varepsilon_B, \\
& ((\Pi_1 \otimes \Pi_1) \circ \Phi_{\Pi_2} \otimes \text{id}_B) \circ (\Pi_2 \otimes \Psi_{B,B}) \circ (\Delta_B \circ \Pi_1 \otimes \Pi_2) \\
& \quad = \eta_B \otimes \eta_B \otimes \Pi_1 \otimes \varepsilon_B, \\
& (\Pi_1 \otimes \text{id}_B) \circ \delta_{(2,2,0)} \circ (\text{id}_B \otimes \Pi_1) = \eta_B \circ \varepsilon_B \otimes \Pi_1, \\
& (\Pi_1 \otimes \Pi_2 \circ m_B \circ (\text{id}_B \otimes \Pi_2) \otimes \text{id}_B \otimes \Pi_1) \\
& \quad \circ (\Psi_{B,B} \otimes \Phi_{\Pi_2} \otimes \text{id}_B) \circ (\text{id}_B \otimes (\Psi_{B,B} \otimes \text{id}_B \otimes \text{id}_B)) \\
& \quad \circ (\Pi_1 \otimes (\Delta_B \circ \Pi_1 \otimes \text{id}_B) \circ \Delta_B \circ \Pi_2)) \\
& \quad = ((\Pi_1 \otimes \Pi_2 \circ m_B) \circ (\Psi_{B,B} \otimes \text{id}_B) \circ (\text{id}_B \otimes \Delta_B) \otimes \Pi_1 \otimes \Pi_1) \\
& \quad \circ (\text{id}_B \otimes (\Psi_{B,B} \otimes \text{id}_B) \circ (\text{id}_B \otimes (\Pi_1 \otimes \text{id}_B) \circ \Delta_B \circ \Pi_2))
\end{aligned} \tag{3.22}$$

and the corresponding  $\pi$ -symmetric counterparts.

We used  $\Phi_f := (m_B \otimes \text{id}_B) \circ (f \otimes \Psi_{B,B}) \circ (\Delta_B \otimes \text{id}_B)$  for  $f : B \rightarrow B$ , and  $\delta_{(i,j,k)}$  of Theorem 3.6.

Recall Remark 5 and observe that our construction of (strong/cocycle) cross product bialgebras is invariant under  $\pi$ -symmetry. However, cross product bialgebras in general fail to be invariant if duality or rotational symmetry along a vertical axis (in the plane of the paper) will be transformed separately. Without problems the dual versions of cross product bialgebras can be defined using our original definition. The corresponding results follow immediately. If the category  $\mathcal{C}$  has (right) duality then the following proposition shows how dual cross product bialgebras can be constructed explicitly.

**PROPOSITION 3.9.** *Suppose that  $\mathcal{C}$  is a braided category with duality functor  $(-)^{\vee} : \mathcal{C} \rightarrow \mathcal{C}_{\text{op}}^{\text{op}}$  where  $\mathcal{C}_{\text{op}}^{\text{op}}$  is the opposite category with opposite tensor product. If  $(B; B_1, B_2, i_1, i_2, p_1, p_2)$  is a (strong/cocycle) cross product bialgebra in  $\mathcal{C}$  then the dual tuple  $(B^{\vee}; B_1^{\vee}, B_2^{\vee}, i_1^{\vee}, i_2^{\vee}, p_1^{\vee}, p_2^{\vee})$  is a dual (strong/cocycle) cross product bialgebra in  $\mathcal{C}_{\text{op}}^{\text{op}}$ .*

#### 4. HOPF DATA

In Section 3 we studied cross product bialgebras from a universal point of view. We answered the question under which conditions a bialgebra is isomorphic to a cross product bialgebra. Now we present an explicit (co-)modular cocyclic construction method in terms of Hopf data. A Hopf datum consists of two objects with certain interrelated (co-)modular cocyclic identities. In Theorem 4.4 we will show that so-called strong Hopf

data and strong cross product bialgebras are different descriptions of the same objects. Universality of our “strong” construction will be demonstrated in Theorem 4.5. We postpone the lengthy proof of Theorem 4.4 to Section 5. In the subsequent definition of Hopf data occur two objects  $B_1$  and  $B_2$ , and morphisms

$$\begin{aligned}
 m_1 &: B_1 \otimes B_1 \rightarrow B_1, & m_2 &: B_2 \otimes B_2 \rightarrow B_2, \\
 \Delta_1 &: B_1 \rightarrow B_1 \otimes B_1, & \Delta_2 &: B_2 \rightarrow B_2 \otimes B_2, \\
 \eta_1 &: \mathbb{1} \rightarrow B_1, & \eta_2 &: \mathbb{1} \rightarrow B_2, \\
 \varepsilon_1 &: B_1 \rightarrow \mathbb{1}, & \varepsilon_2 &: B_2 \rightarrow \mathbb{1}, \\
 \mu_l &: B_2 \otimes B_1 \rightarrow B_1, & \nu_l &: B_1 \rightarrow B_2 \otimes B_1, \\
 \mu_r &: B_2 \otimes B_1 \rightarrow B_2, & \nu_r &: B_2 \rightarrow B_2 \otimes B_1, \\
 \sigma &: B_2 \otimes B_2 \rightarrow B_1, & \rho &: B_2 \rightarrow B_1 \otimes B_1.
 \end{aligned} \tag{4.1}$$

Again we use the graphical presentation of Fig. 1 for these morphisms, and we represent  $\sigma$  and  $\rho$  by  $\sigma = \text{⌣}$ :  $B_2 \otimes B_2 \rightarrow B_1$  and  $\rho = \text{⌠}$ :  $B_2 \rightarrow B_1 \otimes B_1$ . Similarly as in (3.8) we define morphisms  $\varphi_{1,2}$ ,  $\varphi_{2,1}$ ,  $\hat{\sigma}$ , and  $\hat{\rho}$  by

$$\begin{aligned}
 \varphi_{1,2} &:= (m_2 \otimes m_1) \circ (\text{id}_{B_1} \otimes \Psi_{B_1, B_2} \otimes \text{id}_{B_2}) \circ (\nu_l \otimes \nu_r), \\
 \varphi_{2,1} &:= (\mu_l \otimes \mu_r) \circ (\text{id}_{B_2} \otimes \Psi_{B_2, B_1} \otimes \text{id}_{B_1}) \circ (\Delta_2 \otimes \Delta_1), \\
 \hat{\sigma} &:= (\sigma \otimes m_2 \circ (\mu_r \otimes \text{id}_{B_2})) \circ (\text{id}_{B_2} \otimes \Psi_{B_2, B_2} \otimes \text{id}_{B_1 \otimes B_2}) \\
 &\quad \circ (\Delta_2 \otimes (\nu_r \otimes \text{id}_{B_2}) \circ \Delta_2), \\
 \hat{\rho} &:= (m_1 \circ (\text{id}_{B_1} \otimes \mu_l) \otimes m_1) \circ (\text{id}_{B_1 \otimes B_2} \otimes \Psi_{B_1, B_1} \otimes \text{id}_{B_1}) \\
 &\quad \circ ((\text{id}_{B_1} \otimes \nu_l) \circ \Delta_1 \otimes \rho)
 \end{aligned}$$

or graphically

$$\varphi_{1,2} := \text{⌣} \quad , \quad \varphi_{2,1} := \text{⌠} \quad , \quad \hat{\rho} := \text{⌠} \quad , \quad \hat{\sigma} := \text{⌣} \tag{4.2}$$

Occasionally we also use the graphical abbreviations

$$\varphi_{1,2} = \text{⌣} \quad , \quad \varphi_{2,1} = \text{⌠} \quad , \quad \hat{\rho} = \text{⌠} \quad , \quad \hat{\sigma} = \text{⌣} \tag{4.3}$$

**DEFINITION 4.1.** The tuple  $\mathfrak{h} = ((B_1, m_1, \eta_1, \Delta_1, \varepsilon_1), (B_2, m_2, \eta_2, \Delta_2, \varepsilon_2); \mu_l, \mu_r, \nu_l, \nu_r, \rho, \sigma)$  is called a Hopf datum if

(1)  $(B_1, m_1, \eta_1)$  is an algebra and  $\varepsilon_1 : B_1 \rightarrow \mathbb{1}$  is an algebra morphism.

(2)  $(B_2, \Delta_2, \varepsilon_2)$  is a coalgebra and  $\eta_2 : \mathbb{1} \rightarrow B_2$  is a coalgebra morphism.

(3)  $(B_1, \nu_l)$  is a left  $B_2$ -comodule.

(4)  $(B_2, \mu_r)$  is a right  $B_1$ -module.

(5) The identities

$$\begin{aligned}
 \Delta_1 \circ \eta_1 &= \eta_1 \otimes \eta_2, & (\text{id}_{B_1} \otimes \varepsilon_1) \circ \Delta_1 &= (\varepsilon_1 \otimes \text{id}_{B_1}) \circ \Delta_1 = \text{id}_{B_1}, \\
 \varepsilon_2 \circ m_2 &= \varepsilon_2 \otimes \varepsilon_2, & m_2 \circ (\text{id}_{B_2} \otimes \eta_2) &= m_2 \circ (\eta_2 \otimes \text{id}_{B_2}) = \text{id}_{B_2}, \\
 \mu_r \circ (\eta_2 \otimes \text{id}_{B_1}) &= \eta_2 \circ \varepsilon_1, & \varepsilon_2 \circ \mu_r &= \varepsilon_2 \otimes \varepsilon_1, \\
 (\text{id}_{B_2} \otimes \varepsilon_1) \circ \nu_l &= \eta_2 \circ \varepsilon_1, & \nu_l \circ \eta_1 &= \eta_2 \otimes \eta_1, \\
 \mu_l \circ (\eta_2 \otimes \text{id}_{B_1}) &= \text{id}_{B_1}, & \mu_l \circ (\text{id}_{B_2} \otimes \eta_1) &= \eta_1 \circ \varepsilon_2, \\
 \varepsilon_1 \circ \mu_l &= \varepsilon_2 \otimes \varepsilon_1, & (\text{id}_{B_2} \otimes \varepsilon_1) \circ \nu_r &= \text{id}_{B_2}, \\
 (\varepsilon_2 \otimes \text{id}_{B_1}) \circ \nu_r &= \eta_1 \circ \varepsilon_2, & \nu_r \circ \eta_2 &= \eta_2 \otimes \eta_1, \\
 \sigma \circ (\eta_2 \otimes \text{id}_{B_2}) &= \sigma \circ (\text{id}_{B_2} \otimes \eta_2) = \eta_1 \circ \varepsilon_2, & \varepsilon_1 \circ \sigma &= \varepsilon_2 \otimes \varepsilon_2, \\
 (\text{id}_{B_1} \otimes \varepsilon_1) \circ \rho &= (\varepsilon_1 \otimes \text{id}_{B_1}) \circ \rho = \eta_1 \circ \varepsilon_2, & \rho \circ \eta_2 &= \eta_1 \otimes \eta_1
 \end{aligned} \tag{4.4}$$

are satisfied.

(6) The subsequent compatibility relations hold.

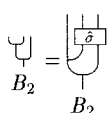

Weak associativity of  $m_2$ ,

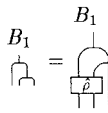

Weak coassociativity of  $\Delta_1$ ,

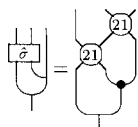

Weak associativity of  $\mu_l$ ,

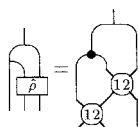

Weak coassociativity of  $\nu_r$ ,



Module-algebra compatibility,

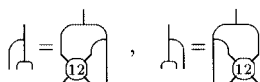

Comodule-coalgebra compatibility,

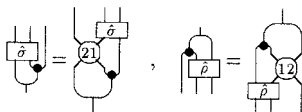

Cocycle and cycle compatibilities,

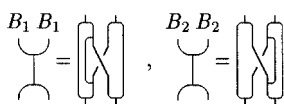

Algebra-coalgebra compatibility,

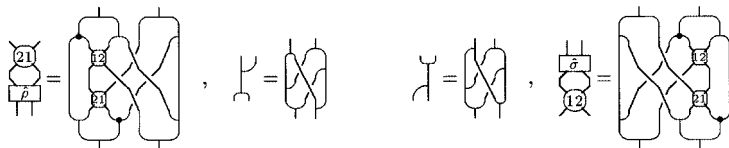

Module-coalgebra compatibility,

Comodule-algebra compatibility,

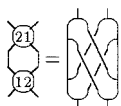

Module-comodule compatibility,

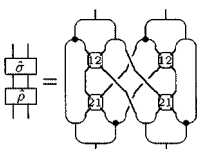

Cycle-cocycle compatibility.

Observe that Definition 4.1 is  $\pi$ -symmetric invariant. It will be verified in the next proposition that every cocycle cross product bialgebra canonically induces a Hopf datum.

PROPOSITION 4.2. Let  $B_1 \overset{\hat{\rho}}{\varphi_{1,2}} \bowtie \overset{\hat{\sigma}}{\varphi_{2,1}} B_2$  be a cocycle cross product bialgebra with corresponding structure morphisms  $m_1, \eta_1, \Delta_1, \varepsilon_1, m_2, \eta_2, \Delta_2, \varepsilon_2, \mu_l, \mu_r, \nu_l, \nu_r, \rho,$  and  $\sigma$ . Then  $((B_1, m_1, \eta_1, \Delta_1, \varepsilon_1), (B_2, m_2, \eta_2, \Delta_2, \varepsilon_2); \mu_l, \mu_r, \nu_l, \nu_r, \rho, \sigma)$  is a Hopf datum.

Proof. By definition cocycle cross product bialgebras are cocycle cross product algebras and cycle cross product coalgebras in particular. Hence  $(B_1, m_1, \eta_1)$  is an algebra and  $(B_2, \Delta_2, \varepsilon_2)$  is a coalgebra. Since cocycle cross product bialgebras are normalized one deduces with (3.6) that  $\eta_2 : \mathbb{1} \rightarrow B_2$  is an algebra morphism and  $\varepsilon_1 : B_1 \rightarrow \mathbb{1}$  is a coalgebra morphism. Then the conditions of Definition 4.1.1 and 4.1.2 hold. The first (co-)unital identities of (4.4) hold by assumption (see (3.6)). Then from (3.8) one easily derives

$$\begin{aligned}
 \varphi_{1,2} \circ (\eta_1 \otimes \text{id}_{B_2}) &= \nu_r, & (\varepsilon_1 \otimes \text{id}_{B_2}) \circ \varphi_{2,1} &= \mu_r, & \hat{\rho} \circ (\eta_1 \otimes \text{id}_{B_1}) &= \rho \\
 \varphi_{1,2} \circ (\text{id}_{B_1} \otimes \eta_2) &= \nu_l, & (\text{id}_{B_1} \otimes \varepsilon_2) \circ \varphi_{2,1} &= \mu_l, & (\text{id}_{B_2} \otimes \varepsilon_2) \circ \hat{\sigma} &= \sigma.
 \end{aligned}
 \tag{4.5}$$

Since  $B_1 \hat{\varphi}_{1,2} \hat{\bowtie} \hat{\varphi}_{2,1} B_2$  is especially a cocycle cross product algebra, the identities (2.3) are satisfied. Composing the fifth equation of (2.3) with  $(\varepsilon_1 \otimes \text{id}_{B_2}) \circ |$  and using (4.5) proves that  $(B_2, \mu_r)$  is a right  $B_1$ -module. Similarly the weak associativity of  $\mu_l$  is shown by composing with  $(\text{id}_{B_1} \otimes \varepsilon_2) \circ |$ . From (4.5) and (2.3) it will be concluded straightforwardly that  $\sigma \circ (\eta_2 \otimes \text{id}_{B_2}) = (\text{id}_{B_1} \otimes \varepsilon_2) \circ \hat{\sigma} \circ (\eta_2 \otimes \text{id}_{B_2}) = (\text{id}_{B_1} \otimes \varepsilon_2) \circ (\eta_1 \otimes \text{id}_{B_2}) = \eta_1 \circ \varepsilon_2$  and similarly  $\sigma \circ (\eta_2 \otimes \text{id}_{B_2}) = \eta_1 \circ \varepsilon_2$ . Since  $B_1 \hat{\varphi}_{1,2} \hat{\bowtie} \hat{\varphi}_{2,1} B_2$  is a cross product bialgebra,  $\varepsilon_1 \otimes \varepsilon_2$  is an algebra morphism, and therefore one easily shows that  $\varepsilon_1 \circ \sigma = \varepsilon_2 \otimes \varepsilon_2$ . Eventually all other (co-)unital identities of (4.4) follow then by  $\pi$ -symmetry. The weak associativity for  $m_2$  follows now from the sixth equation of (2.3) by adjoining  $(\varepsilon_1 \otimes \text{id}_{B_2}) \circ |$  on both sides. The module-algebra compatibility will be derived from the fifth equation of (2.3) through composition with  $(\text{id}_{B_1} \otimes \varepsilon_2) \circ |$ . Making use of the bialgebra identity  $\Delta_B \circ m_B = (m_B \otimes m_B) \circ (\text{id}_B \otimes \Psi_{B,B} \otimes \text{id}_B) \circ (\Delta_B \otimes \Delta_B)$  for  $B = B_1 \hat{\varphi}_{1,2} \hat{\bowtie} \hat{\varphi}_{2,1} B_2$  we prove the algebra-coalgebra compatibility by application of  $| \circ (\text{id}_{B_1} \otimes \eta_2 \otimes \text{id}_{B_1} \otimes \eta_2)$  and  $(\text{id}_{B_1} \otimes \text{id}_{\varepsilon_2} \otimes \text{id}_{B_1} \otimes \varepsilon_2) \circ |$  on both sides of the bialgebra identity. The first equation of the module-coalgebra compatibility will be shown similarly by composing with  $| \circ (\eta_1 \otimes \text{id}_{B_2} \otimes \text{id}_{B_1} \otimes \eta_2)$  and  $(\varepsilon_1 \otimes \text{id}_{B_2} \otimes \varepsilon_1 \otimes \text{id}_{B_2}) \circ |$ . Application of  $| \circ (\eta_1 \otimes \text{id}_{B_2} \otimes \text{id}_{B_1} \otimes \eta_2)$  and  $(\text{id}_{B_1} \otimes \varepsilon_2 \otimes \text{id}_{B_1} \otimes \varepsilon_2) \circ |$  yields the second equation of the module-coalgebra compatibility. The module-comodule compatibility is derived from the bialgebra identity by composing with  $| \circ (\eta_1 \otimes \text{id}_{B_2} \otimes \text{id}_{B_1} \otimes \eta_2)$  and  $(\varepsilon_1 \otimes \text{id}_{B_2} \otimes \text{id}_{B_1} \otimes \varepsilon_2) \circ |$ , whereas the cycle-cocycle compatibility comes from composition with  $| \circ (\eta_1 \otimes \text{id}_{B_2} \otimes \eta_1 \otimes \text{id}_{B_2})$  and  $(\text{id}_{B_1} \otimes \varepsilon_2 \otimes \text{id}_{B_1} \otimes \varepsilon_2) \circ |$ . Application of  $(\text{id}_{B_1} \otimes \varepsilon_2) \circ |$  to the sixth equation of (2.3) and use of the sixth identity of (4.5) yield the cocycle compatibility. All remaining compatibility relations of Definition 4.1 will be proven by application of  $\pi$ -symmetry to the former results. ■

*Strong Hopf Data*

The converse of Proposition 4.2 is not true in general. However, in the following we show that so-called strong Hopf data yield cross product bialgebras. The definition of strong Hopf data is closely related to the definition of strong cross product bialgebras.

DEFINITION 4.3. A Hopf datum  $\mathfrak{h}$  is called strong if in addition the following identities hold.

$$\begin{array}{c} \diagup \diagdown \\ \diagdown \diagup \end{array} = \begin{array}{c} \diagup \\ \diagdown \end{array} \circ \begin{array}{c} \diagdown \\ \diagup \end{array}, \quad \begin{array}{c} \diagdown \diagup \\ \diagup \diagdown \end{array} = \begin{array}{c} \diagdown \\ \diagup \end{array} \circ \begin{array}{c} \diagup \\ \diagdown \end{array} \quad (4.6)$$

$$\begin{array}{c} \diagup \diagdown \\ \diagdown \diagup \end{array} = \begin{array}{c} \diagup \\ \diagdown \end{array} \circ \begin{array}{c} \diagdown \\ \diagup \end{array} \circ \begin{array}{c} \diagdown \\ \diagup \end{array}, \quad \begin{array}{c} \diagdown \diagup \\ \diagup \diagdown \end{array} = \begin{array}{c} \diagdown \\ \diagup \end{array} \circ \begin{array}{c} \diagup \\ \diagdown \end{array} \circ \begin{array}{c} \diagdown \\ \diagup \end{array}, \quad \begin{array}{c} \diagdown \\ \diagup \end{array} \circ \begin{array}{c} \diagdown \\ \diagup \end{array} = \begin{array}{c} \diagdown \\ \diagup \end{array} \circ \begin{array}{c} \diagdown \\ \diagup \end{array}, \quad \begin{array}{c} \diagup \\ \diagdown \end{array} \circ \begin{array}{c} \diagup \\ \diagdown \end{array} = \begin{array}{c} \diagup \\ \diagdown \end{array} \circ \begin{array}{c} \diagup \\ \diagdown \end{array} \quad (4.7)$$

(4.8)

Strong Hopf data are invariant under  $\pi$ -symmetry. This fact will be used extensively in Section 5 where we prove Theorem 4.4.

*Remark 12.* Observe that except for (4.8) and the first and the second identities of (4.7) the defining identities of a strong Hopf datum are either of rank (2, 2), (1, 3), or (3, 1). Therefore in the same way as in Remark 11 we call a strong Hopf datum *regular* if the defining identities are of either rank (2, 2), (1, 3), or (3, 1). We call the strong Hopf datum *pure* if (4.6), (4.7), and (4.8) are redundant.

*Main Results*

This is the central part of the article. In the subsequent Theorems 4.4 and 4.5 we present the universal (co-)modular cocyclic theory of (strong) cross product bialgebras. In Theorem 4.4 we describe the (co-)modular cocyclic construction of strong cross product bialgebras. Theorem 4.5 exhibits its universality.

**THEOREM 4.4.** *Let  $\mathfrak{h} = ((B_1, m_1, \eta_1, \Delta_1, \varepsilon_1), (B_2, m_2, \eta_2, \Delta_2, \varepsilon_2); \mu_l, \mu_r, \nu_l, \nu_r, \rho, \sigma)$  be a strong Hopf datum. Then  $B_1 \otimes B_2$  with  $\varphi_{1,2}, \varphi_{2,1}, \hat{\sigma}$ , and  $\hat{\rho}$  defined according to (4.2) is a strong cross product bialgebra  $B_1 \overset{\mathfrak{h}}{\bowtie} B_2$ . Strong Hopf data and strong cross product bialgebras are in one-to-one correspondence.*

Every strong Hopf datum  $\mathfrak{h}$  therefore induces a strong cross product bialgebra  $B_1 \overset{\mathfrak{h}}{\bowtie} B_2$ . For any bialgebra  $B$  which is isomorphic to  $B_1 \overset{\mathfrak{h}}{\bowtie} B_2$  the additional relations (4.6)–(4.8) (or by one-to-one correspondence Eqs. (3.19)–(3.21)) imply the additional relations (3.22) for the idempotents  $\Pi_1$  and  $\Pi_2$  of  $B$ .

**THEOREM 4.5.** *Let  $B$  be a bialgebra in  $\mathcal{C}$ . Then the following statements are equivalent.*

- (1) *There is a strong Hopf datum  $\mathfrak{h}$  such that the corresponding strong cross product bialgebra  $B_1 \overset{\mathfrak{h}}{\bowtie} B_2$  is bialgebra isomorphic to  $B$ .*
- (2) *There are idempotents  $\Pi_1, \Pi_2 \in \text{End}(B)$  such that the conditions of Theorem 3.2.2 and the “strong projection” relations (3.22) hold.*
- (3) *There are objects  $B_1$  and  $B_2$  and morphisms  $B_1 \xrightarrow{i_1} B \xrightarrow{p_1} B_1$  and  $B_2 \xrightarrow{i_2} B \xrightarrow{p_2} B_2$  such that the conditions of Theorem 3.2.3 and the “strong projection” relations (3.22) hold with  $\Pi_j := i_j \circ p_j$ .*

*Proof.* Theorem 4.5 can be derived straightforwardly from Theorem 4.4, Theorem 3.2, (Theorem 3.6), Remark 6, Remark 11, and the relations (3.22). ■

In the sequel we will consider special versions of strong cross product bialgebras. They admit equivalent universal and (co-)modular co-cyclic descriptions and can be derived from the most general construction given in Theorem 4.4. In particular all known constructions of cocycle cross product bialgebras will be recovered, and additionally we find several new types of cocycle cross product bialgebras. In Proposition 4.6 we describe comprehensively the universal and (co-)modular cocyclic properties of one of these special types.

Theorem 4.4 and Proposition 3.7 provide the necessary tools to describe the various subclasses. We distinguish the different special versions of strong cross product bialgebras with the help of the boxes

$\mu_l$	$\mu_r$
$\sigma$	$\rho$
$\nu_l$	$\nu_r$

where the particular entries will be left blank “ ” or take the values  $\bullet$  for the (weak) (co-)actions,  $\blacktriangledown$  for  $\sigma$ , and  $\blacktriangle$  for  $\rho$  dependent on whether the respective morphisms are trivial or not. For example, a strong cross product bialgebra with trivial cocycle  $\sigma = \eta_1 \circ (\varepsilon_2 \otimes \varepsilon_2)$  and trivial right coaction  $\nu_r = \text{id}_{B_2} \otimes \eta_1$  will be represented by the classification box

$\bullet$	$\bullet$
	$\blacktriangle$
$\bullet$	

Thereby  $2^6 = 64$  types of special strong cross products can be obtained;  $2^4 = 16$  of them are cocycle free. In a similar (dual) way the dual strong cross product bialgebras will be denoted by a classification box

$\mu_l$	$\mu_r$
$\sigma$	$\rho$
$\nu_l$	$\nu_r$

with entries  $\bullet$  for the (co)actions,  $\blacktriangle$  for the cocycle  $\sigma$ , and  $\blacktriangledown$  for the cycle  $\rho$ . Then analogously 64 special types of dual strong cross product bialgebras can be obtained from which  $2^4 = 16$  (cocycle free) types coincide with the corresponding 16 types of strong cross product bialgebras. Therefore the total number of different types of strong and dual strong cross product bialgebras which is classified by our scheme is  $2^6 + (2^6 - 2^4) = 7 \cdot 2^4 = 112$ . However, henceforth we do not distinguish between a certain type and its dual or  $\pi$ -symmetric counterparts—it is an easy exercise to obtain one from



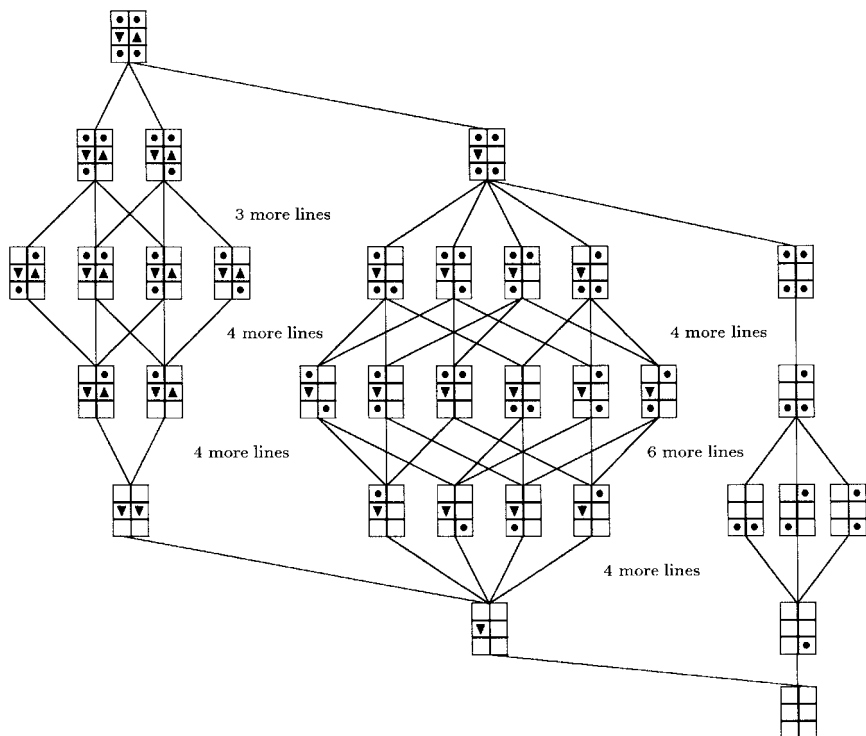
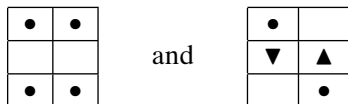

FIG. 2. Graph representing the various special versions of strong cross product bialgebras.

the other.<sup>7</sup> Up to this  $\mathbb{Z}_2 \times \mathbb{Z}_2$ -symmetry we obtain 33 different classification boxes. In Fig. 2 we present a graph where the boxes (modulo  $\mathbb{Z}_2 \times \mathbb{Z}_2$ -symmetry) are the vertices, and each box is linked with its descending “next neighbour” special versions. We stratify the whole graph into three layers. The layers consist of boxes with 2, 1, or 0 cocycles, respectively. The most general type of strong cross product bialgebra (Theorem 4.4) is at the top of the graph in the first row. In the second row all descendants with one trivial morphism  $\mu_l, \mu_r, \sigma, \rho, \nu_l$ , or  $\nu_r$  are listed; in the third row all special types with two trivial morphisms are listed, etc. The cross product bialgebra constructions from [5, 18, 20, 22, 24] are descendants of the special cases



<sup>7</sup>Observe that a  $\pi$ -rotation of the classification box in the plane of the graphic yields the corresponding  $\pi$ -symmetric counterpart of a certain type of cross product bialgebra. Analogously a reflection of the classification box along a horizontal line yields the dual counterpart.

which are the cocycle free cross product bialgebras of [5] and the braided versions of bicrossed product bialgebras [20, 22], respectively.<sup>8</sup> In Tables I–III we describe the different types of cocycle cross product bialgebras in more detail; we omit the description of the various cross product bialgebras studied in [5, 18, 20, 22, 24]. In the second column of the tables the structure of the multiplication  $m_B$  and the comultiplication  $\Delta_B$  is given. In the third column we recall the corresponding equivalent properties of Proposition 3.7; and in the last column the status of the strong cross product bialgebra is listed.

Exemplarily we will describe the explicit structure of the cross product bialgebras of type

•	•
▼	
	•

They consist of two objects  $B_1$  and  $B_2$  such that

- (1)  $(B_1, m_1, \eta_1, \Delta_1, \varepsilon_1)$  is a bialgebra.
- (2)  $(B_2, \Delta_2, \varepsilon_2, \mu_r, \nu_r)$  is  $B_1$ -module coalgebra and  $B_1$ -comodule coalgebra and  $\eta_2 : \mathbb{1} \rightarrow B_2$  is coalgebra morphism.

(3) Let

$$\begin{aligned}
 \varepsilon_2 \circ m_2 &= \varepsilon_2 \otimes \varepsilon_2, & m_2 \circ (\text{id}_{B_2} \otimes \eta_2) &= m_2 \circ (\eta_2 \otimes \text{id}_{B_2}) = \text{id}_{B_2}, \\
 \mu_r \circ (\eta_2 \otimes \text{id}_{B_1}) &= (\text{id}_{B_2} \otimes \varepsilon_1) \circ \nu_l = \eta_2 \circ \varepsilon_1, & \nu_l \circ \eta_1 &= \eta_2 \otimes \eta_1, \\
 \mu_l \circ (\eta_2 \otimes \text{id}_{B_1}) &= \text{id}_{B_1}, & \mu_l \circ (\text{id}_{B_2} \otimes \eta_1) &= \eta_1 \circ \varepsilon_2, \\
 \varepsilon_1 \circ \mu_l &= \varepsilon_2 \otimes \varepsilon_1, & \nu_r \circ \eta_2 &= \eta_2 \otimes \eta_1, \\
 \sigma \circ (\eta_2 \otimes \text{id}_{B_2}) &= \sigma \circ (\text{id}_{B_2} \otimes \eta_2) = \eta_1 \circ \varepsilon_2, & \varepsilon_1 \circ \sigma &= \varepsilon_2 \otimes \varepsilon_2, \\
 (\text{id}_{B_1} \otimes \varepsilon_1) \circ \rho &= (\varepsilon_1 \otimes \text{id}_{B_1}) \circ \rho = \eta_1 \circ \varepsilon_2, & \rho \circ \eta_2 &= \eta_1 \otimes \eta_1.
 \end{aligned} \tag{4.9}$$

- (4) The weak associativity of  $m_2$  and of  $\mu_l$  in Definition 4.1 holds.
- (5) The module-algebra compatibility of Definition 4.1 is satisfied.
- (6) The cocycle compatibility of  $\hat{\sigma}$  holds.
- (7) The algebra-coalgebra compatibility of  $B_2$  holds.

<sup>8</sup>A special symmetric version of

•	•
▼	
	•

has been studied recently in [26].

TABLE 1

Type	Structure morphisms $m_B, \Delta_B$	Proposition 3.7	Status
		3.7.4	
		3.7.3	
		3.7.6	
		3.7.1, 3.7.4	regular
		3.7.3, 3.7.4	











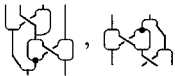

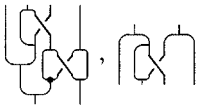

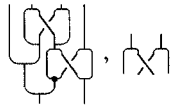
(8) The module-coalgebra compatibility of  $\mu_l$ , the comodule-algebra compatibility of  $\nu_r$ , the module-comodule compatibility, and the cycle-cocycle compatibility are respectively given by

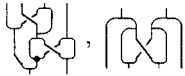
$$\begin{aligned} \Delta_1 \circ \mu_l = & (\mu_l \otimes m_1 \circ (\text{id}_{B_1} \otimes \mu_l)) \circ (\text{id}_{B_2} \otimes \Psi_{B_1 \otimes B_2, B_1} \otimes \text{id}_{B_1}) \\ & \circ ((\nu_r \otimes \text{id}_{B_2}) \circ \Delta_2 \otimes \Delta_1), \\ & (\text{id}_{B_2} \otimes m_1) \circ (\Psi_{B_1, B_2} \otimes \text{id}_{B_1}) \circ (\text{id}_{B_1} \otimes \nu_r) \circ \hat{\sigma} \end{aligned}$$

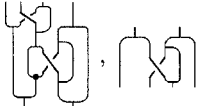
TABLE 2

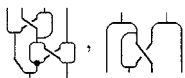
Type	Structure morphisms $m_B, \Delta_B$	Proposition 3.7	Status
		3.7.2, 3.7.4	regular
		3.7.2, 3.7.3	pure
		3.7.2, 3.7.6	
		3.7.3, 3.7.6	pure
		3.7.8	regular
		3.7.1, 3.7.5	
		3.7.5, 3.7.6	regular
		3.7.6, 3.7.7	pure

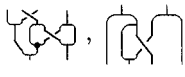
TABLE 3

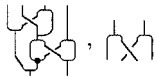
Type	Structure morphisms $m_B, \Delta_B$	Proposition 3.7	Status
		3.7.1, 3.7.3, 3.7.4	regular
		3.7.2, 3.7.8	regular
		3.7.3, 3.7.8	pure
		3.7.1, 3.7.2, 3.7.6	
		3.7.1, 3.7.3, 3.7.6	pure
		3.7.1, 3.7.8	regular
		3.7.1, 3.7.2, 3.7.8	regular
		3.7.1, 3.7.3, 3.7.8	pure

*Note.* There are various redundant and special relations among the defining identities of the particular cases listed above. They can be derived from Theorem 4.4.

$$\begin{aligned}
&= (\mathfrak{m}_2 \otimes \mathfrak{m}_1 \circ (\mathfrak{m}_1 \otimes \sigma) \circ (\text{id}_{B_1} \otimes \varphi_{2,1} \otimes \text{id}_{B_2})) \\
&\quad \circ (\text{id}_{B_2} \otimes \Psi_{B_1 \otimes B_2, B_2} \otimes \text{id}_{B_1 \otimes B_2}) \\
&\quad \circ ((\nu_r \otimes \text{id}_{B_2}) \circ \Delta_2 \otimes (\nu_r \otimes \text{id}_{B_2}) \circ \Delta_2), \\
&\quad (\text{id}_{B_2} \otimes \mathfrak{m}_1) \circ (\Psi_{B_1, B_2} \otimes \text{id}_{B_1}) \circ (\text{id}_{B_1} \otimes \nu_r) \circ \varphi_{2,1} \\
&= (\mu_r \otimes \mathfrak{m}_1 \circ (\text{id}_{B_1} \otimes \mu_l)) \circ (\text{id}_{B_2} \otimes \Psi_{B_1 \otimes B_2, B_1} \otimes \text{id}_{B_1}) \\
&\quad \circ ((\nu_r \otimes \text{id}_{B_2}) \circ \Delta_2 \otimes \Delta_1), \\
\Delta_1 \circ \sigma &= (\sigma \otimes \mathfrak{m}_1 \circ (\mathfrak{m}_1 \otimes \sigma) \circ (\text{id}_{B_1} \otimes \varphi_{2,1} \otimes \text{id}_{B_2})) \\
&\quad \circ (\text{id}_{B_2} \otimes \Psi_{B_1 \otimes B_2, B_2} \otimes \text{id}_{B_1 \otimes B_2}) \\
&\quad \circ ((\nu_r \otimes \text{id}_{B_2}) \circ \Delta_2 \otimes (\nu_r \otimes \text{id}_{B_2}) \circ \Delta_2).
\end{aligned}$$

The set of defining identities of the idempotents  $\Pi_1$  and  $\Pi_2$  and of the projections and injections  $p_1, p_2, i_1, i_2$  can be determined similarly. Eventually the universal properties of the cross product bialgebras of type

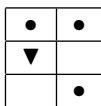

will be described by the following proposition. We will use the notations of Corollary 3.4 and Remark 11.

**PROPOSITION 4.6.** *Let  $B$  be a bialgebra in  $\mathcal{C}$ . Then the following equivalent conditions are satisfied.*

- (1)  *$B$  is isomorphic to a cross product bialgebra  $B_1 \bowtie B_2$  where  $\Delta_{21,1} = \eta_2 \otimes \text{id}_{B_1}$  and  $\Delta_{11,2} = (\eta_1 \otimes \eta_1) \circ \varepsilon_2$  are trivial.*
- (2) *There are idempotents  $\Pi_1, \Pi_2 \in \text{End}(B)$  such that*
  - (a)  $\mathfrak{m}_B \circ (\Pi_1 \otimes \Pi_1) = \Pi_1 \circ \mathfrak{m}_B \circ (\Pi_1 \otimes \Pi_1)$ ,
  - (b)  $\Pi_1$  is a coalgebra morphism,
  - (c)  $(\Pi_2 \otimes \Pi_2) \circ \Delta_B = (\Pi_2 \otimes \Pi_2) \circ \Delta_B \circ \Pi_2$ ,
  - (d)  $\Pi_1 \circ \eta_B = \eta_B$  and  $\varepsilon_B \circ \Pi_2 = \varepsilon_B$ ,
  - (e)  $\mathfrak{m}_B \circ (\Pi_1 \otimes \Pi_2)$  and  $(\Pi_1 \otimes \Pi_2) \circ \Delta_B$  split the idempotent  $\Pi_1 \otimes \Pi_2$ .
- (3) *There are objects  $B_1$  and  $B_2$  and morphisms  $B_1 \xrightarrow{i_1} A \xrightarrow{p_1} B_1$  and  $B_2 \xrightarrow{i_2} A \xrightarrow{p_2} B_2$  such that*
  - (a)  $i_1$  is an algebra and coalgebra morphism,
  - (b)  $p_1$  is a coalgebra morphism,
  - (c)  $p_2$  is a coalgebra morphism,

(d)  $p_j \circ i_j = \text{id}_{B_j}$  for  $j \in \{1, 2\}$ ,

(e)  $m_A \circ (i_1 \otimes i_2) : B_1 \otimes B_2 \rightarrow A$  is an isomorphism with inverse  $(p_1 \otimes p_2) \circ \Delta_A$ .

### Concluding Remarks

We found a universal theory of strong cross product bialgebras with an equivalent (co-)modular cocyclic characterization in terms of strong Hopf data. The theory unites all known cross product bialgebras [5, 18, 20–22, 24] in a single construction. Furthermore various new types of cross product bialgebras arise out of the most general construction. The (co-)modular cocyclic structure of strong cross product bialgebras corresponds canonically to a strong Hopf datum which in turn completely determines the bialgebra structure.

Thus Hopf data basically provide a pattern for the realization of cross product bialgebras in terms of explicit examples—a task to be done in future investigations.

There is no conceptual explanation yet for the understanding of the strong conditions in Definition 4.3. A canonical origin of these conditions may be found in higher dimensional categorical constructions of cross product bialgebras where the two tensor factors of the strong cross product bialgebras will be considered as an object of two different monoidal categories.

Since we are working throughout in braided categories, the results of the article may now be used to investigate cross product bialgebras in various types of braided categories (see [5, 6] for applications in Hopf bimodule categories).

Our directions of study of cross product bialgebras are particularly concerned with these questions as well as with extension theory and cohomological considerations (see [14, 28, 29]).

## 5. PROOF OF THEOREM 4.4

This section is exclusively devoted to the proof of Theorem 4.4. In what follows we denote by  $\mathfrak{h} = ((B_1, m_1, \eta_1, \Delta_1, \varepsilon_1), (B_2, m_2, \eta_2, \Delta_2, \varepsilon_2); \mu_l, \mu_r, \nu_l, \nu_r, \rho, \sigma)$  a strong Hopf datum. Although many of the subsequent results hold for more general Hopf data, we do not explicitly point out this fact in the particular lemmas and propositions. The reader will easily verify which of the following results hold under more general assumptions. Before we start proving the theorem we would like to explain some useful notations and results on Hopf data which will be used subsequently.

*Basic Properties of Strong Hopf Data*

For a finite set  $I = \{i_1, \dots, i_r\}$  of indices  $i_k \in \{1, 2\}$ ,  $k \in \{1, \dots, r\}$  we denote  $B_I := B_{i_1} \otimes \dots \otimes B_{i_r}$ . Suppose now  $r = |I|$  is the length of the sequence  $I$ . Given morphisms  $f : B_I \otimes B_2 \otimes B_J \rightarrow B_K$  and  $g : B_K \rightarrow B_I \otimes B_2 \otimes B_J$  we define their *relativization*  $f^{[r+1]}$  and  $g_{[r+1]}$  in the  $(r + 1)$ st domain index and codomain index, respectively, by

$$f^{[r+1]} := \begin{array}{c} B_I \quad B_1 B_J \\ \text{---} \text{---} \text{---} \\ \text{---} \text{---} \text{---} \\ \text{---} \text{---} \text{---} \\ B_K \quad B_1 \end{array} \quad \text{and} \quad g_{[r+1]} := \begin{array}{c} B_2 \quad B_K \\ \text{---} \text{---} \\ \text{---} \text{---} \\ \text{---} \text{---} \\ B_1 B_2 B_J \end{array} \quad (5.1)$$

We say that two morphisms  $f$  and  $f'$  coincide relatively if  $f^{[r+1]} = f'^{[r+1]}$ . Similarly  $g_{[r+1]} = g'_{[r+1]}$  means that  $g$  and  $g'$  coincide relatively. Instead of (5.1) we will often use the obvious shorthand notation

$$\begin{array}{c} \text{---} \text{---} \\ \text{---} \text{---} \\ \text{---} \text{---} \\ \text{---} \text{---} \end{array} = \begin{array}{c} \text{---} \text{---} \\ \text{---} \text{---} \\ \text{---} \text{---} \\ \text{---} \text{---} \end{array} \quad \text{and} \quad \begin{array}{c} \text{---} \\ \text{---} \\ \text{---} \\ \text{---} \end{array} = \begin{array}{c} \text{---} \\ \text{---} \\ \text{---} \\ \text{---} \end{array} \quad (5.2)$$

for  $f^{[r+1]} = f'^{[r+1]}$  and  $g_{[r+1]} = g'_{[r+1]}$ , respectively. This means that the identities (5.1) result from (5.2) by braiding the threads with endpoints in the middle of the graphics with all neighbouring strings on the right, respectively on the left, and then completing vertically these threads to the bottom, respectively to the top, of the graphics.

Besides (4.2) and (4.3) we will use the definitions

$$\varphi_{1,1} := \text{---} \text{---} := \text{---} \text{---} \quad , \quad \varphi_{2,2} := \text{---} \text{---} := \text{---} \text{---} \quad (5.3)$$

All subsequent lemmas can be proven straightforwardly with the help of the definition of (strong) Hopf data. We will therefore only sketch the main steps of the derivation of the proofs.

LEMMA 5.1. *Let  $\mathfrak{h}$  be a strong Hopf datum. Then the identities*

$$\begin{array}{c} \text{---} \\ \text{---} \\ \text{---} \end{array} = \text{---} \text{---} \quad , \quad \begin{array}{c} \text{---} \\ \text{---} \\ \text{---} \end{array} = \text{---} \text{---} \quad , \quad \begin{array}{c} \text{---} \\ \text{---} \\ \text{---} \end{array} = \text{---} \text{---} \quad , \quad \begin{array}{c} \text{---} \\ \text{---} \\ \text{---} \end{array} = \text{---} \text{---} \quad (5.4)$$

are satisfied.

*Proof.* The first identity in 5.4 has been obtained from (4.7) and (4.6). With the help of (4.7) and (4.8) the second identity will be derived. Application of  $\pi$ -symmetry completes the proof. ■

The relative associativity of  $m_2$  and  $\mu_l$ , and by  $\pi$ -symmetry the relative coassociativity of  $\Delta_2$  and  $\nu_r$ , will be shown in the following lemma.



LEMMA 5.2. For a strong Hopf datum  $\mathfrak{h}$  the identities

$$\begin{aligned} \begin{array}{c} \cup \\ \cup \end{array} &= \begin{array}{c} \cup \\ \cup \end{array}, & \begin{array}{c} \cup \\ \cup \end{array} &= \begin{array}{c} \cup \\ \cup \end{array}, & \begin{array}{c} \cup \\ \cup \end{array} &= \begin{array}{c} \cup \\ \cup \end{array} \\ \begin{array}{c} \cup \\ \cup \end{array} &= \begin{array}{c} \cup \\ \cup \end{array}, & \begin{array}{c} \cup \\ \cup \end{array} &= \begin{array}{c} \cup \\ \cup \end{array} \end{aligned}$$

and the corresponding  $\pi$ -symmetric versions of the relative coassociativity of  $\Delta_1$  and  $\nu_r$  hold.

*Proof.* The relative associativity of  $m_2$  and  $\mu_l$  will be derived from the respective weak associativity of Definition 4.1 taking into account (4.7) and (5.4) of Lemma 5.1. ■

*Remark 13.* For a Hopf data satisfying  $\begin{array}{c} \cup \\ \cup \end{array} = \begin{array}{c} \cup \\ \cup \end{array}$  and  $\begin{array}{c} \cup \\ \cup \end{array} = \begin{array}{c} \cup \\ \cup \end{array}$  the multiplication  $m_2$  and the comultiplication  $\Delta_1$  are (co-)associative.

LEMMA 5.3. The relative versions of the morphisms  $\varphi_{1,2}$  and  $\varphi_{2,1}$  are given by

$$\begin{array}{c} \cup \\ \cup \end{array} = \begin{array}{c} \cup \\ \cup \end{array} \quad \text{and} \quad \begin{array}{c} \cup \\ \cup \end{array} = \begin{array}{c} \cup \\ \cup \end{array} \tag{5.5}$$

*Proof.* Using that  $(B_2, \mu_r)$  is a right module and applying Lemma 5.1 yields the first identity of (5.5). ■

Then the next lemma follows from the module-algebra and comodule-coalgebra compatibilities of Definition 4.1.

LEMMA 5.4. The identities

$$\begin{array}{c} \cup \\ \cup \end{array} = \begin{array}{c} \cup \\ \cup \end{array}, \quad \begin{array}{c} \cup \\ \cup \end{array} = \begin{array}{c} \cup \\ \cup \end{array} \tag{5.6}$$

$$\begin{array}{c} \cup \\ \cup \end{array} = \begin{array}{c} \cup \\ \cup \end{array}, \quad \begin{array}{c} \cup \\ \cup \end{array} = \begin{array}{c} \cup \\ \cup \end{array} \tag{5.7}$$

are satisfied for a strong Hopf datum  $\mathfrak{h}$ .

LEMMA 5.5. Let  $\mathfrak{h}$  be strong Hopf datum. Then  $(B_1, m_1, \eta_l, \nu_l)$  is a left  $B_2$ -comodule algebra and  $(B_2, \Delta_2, \varepsilon_2, \mu_r)$  is a right  $B_1$ -module coalgebra.

*Proof.* We use Lemma 5.1 and the second identity of the comodule-algebra compatibility of Definition 4.1 to show that  $(B_1, m_1, \eta_l, \nu_l)$  is a left  $B_2$ -comodule algebra. In a  $\pi$ -symmetric manner it will be proven that  $(B_2, \Delta_2, \varepsilon_2, \mu_r)$  is a right  $B_1$ -module coalgebra. ■

LEMMA 5.6. For a strong Hopf datum  $\mathfrak{h}$  the relativizations of the algebra-coalgebra compatibilities, the (left) module-coalgebra compatibility, and the (right) comodule-algebra compatibility are respectively given by

$$\begin{array}{c} \text{Cup} \\ \text{P} \end{array} = \begin{array}{c} \text{Cup} \\ \text{X} \\ \text{P} \end{array}, \quad \begin{array}{c} \text{Cup} \\ \text{P} \end{array} = \begin{array}{c} \text{Cup} \\ \text{X} \\ \text{P} \end{array} \quad (5.8)$$

$$\begin{array}{c} \text{Cup} \\ \text{P} \end{array} = \begin{array}{c} \text{Cup} \\ \text{X} \\ \text{P} \end{array}, \quad \begin{array}{c} \text{Cup} \\ \text{P} \end{array} = \begin{array}{c} \text{Cup} \\ \text{X} \\ \text{P} \end{array} \quad (5.9)$$

$$\begin{array}{c} \text{Cup} \\ \text{P} \end{array} = \begin{array}{c} \text{Cup} \\ \text{X} \\ \text{P} \end{array}, \quad \begin{array}{c} \text{Cup} \\ \text{P} \end{array} = \begin{array}{c} \text{Cup} \\ \text{X} \\ \text{P} \end{array} \quad (5.10)$$

*Proof.* Since  $(B_1, m_1, \eta_1, \nu_1)$  is a left comodule algebra by Lemma 5.5 the first identity in (5.12) follows from the relative associativity of  $m_2$  according to Lemma 5.2.

The verification of (5.9) needs a little more calculation. We prove the first identity of (5.9). The second one can be derived with similar techniques. We start with the second module-coalgebra compatibility in Definition 4.1. We apply the relativization (with  $\mu_r$ ) to the second tensor factor on both sides of the graphic. The left hand side of this relative module-coalgebra compatibility yields the left hand side of the first identity in (5.9) if we consecutively apply modularity of  $(B_2, \mu_r)$ , the second relation of (4.7), and the second relation of (4.6). To obtain the right hand side of the first identity of (5.9) we transform the right hand side of the relative module-coalgebra compatibility using successively the third relation of (4.7), modularity of  $(B_2, \mu_r)$ , the first equation of (5.5), the modularity of  $B_2$ , the second identity of (4.7), and eventually again modularity of  $B_2$ .

All other identities can be derived similarly, in particular because of  $\pi$ -symmetric reasons. ■

In the subsequent Lemmas 5.7 and 5.8 the entwining properties of the morphisms  $\varphi_{1,1}$ ,  $\varphi_{2,2}$ ,  $\varphi_{1,2}$ , and  $\varphi_{2,1}$  will be investigated.

LEMMA 5.7. *The morphism  $\varphi_{1,1}$  entwines with the multiplication  $m_1$ , and  $\varphi_{2,2}$  entwines with the comultiplication  $\Delta_2$  according to*

(5.11)

*Proof.* For the proof of the first identity of Lemma 5.7 we use Lemma 5.5 and the fourth equation of Lemma 5.2. To verify the second identity of (5.11), the module-algebra compatibility for Hopf data, Lemma 5.3, and the comodularity of  $(B_1, \nu_l)$  have to be applied successively. Using the module-algebra compatibility and the  $\pi$ -symmetric version of the fourth identity of Lemma 5.2 yields the fifth identity of (5.11). Simple calculations yield the sixth identity of (5.11). The remaining relations of the lemma follow by  $\pi$ -symmetric reasoning. ■

LEMMA 5.8. *The (relative) entwining identities for  $\varphi_{1,2}$  and  $\varphi_{2,1}$  are given by*

(5.12)

(5.13)

(5.14)

(5.15)

*Proof.* We use Lemma 5.5 for  $B_1$  and the relative associativity of  $m_2$  (Lemma 5.2) to obtain the first identity of (5.12).

The first identity of (5.13) will be used explicitly in the proof of Proposition 5.19. Below we will give its detailed derivation,

$$\varphi_{2,1} \circ (B_2 \otimes m_1) = \text{[Diagram 1]} = \text{[Diagram 2]} = \text{[Diagram 3]} = (m_1 \otimes B_2) \circ \varphi_{2,1,1}$$

where the first equation comes from the relative bialgebra property of  $B_1$  according to (5.8). The second equation can be verified with the help of the module-algebra compatibility of Definition 4.1, and using that  $(B_2, \mu_r)$  is a right module. In the third identity we use the relative associativity of  $\Delta_1$  proven in Lemma 5.2. Finally the result follows because  $(B_2, \Delta_2, \varepsilon_2, \mu_r)$  is a module coalgebra by Lemma 5.5.

The left hand side of the first identity of (5.14) will be transformed to the right hand side of the identity by using successively the algebra-coalgebra compatibility for  $\Delta_2$  and  $m_2$ , the comodularity of  $(B_1, \nu_l)$ , the first relation of (4.6), the first identity of (5.6), the relative associativity of  $\mu_l$  according to Lemma 5.2, and finally the second relation of (5.5).

The first identity of (5.15) immediately follows from the relative module coalgebra properties (5.9).

All other relations of the lemma can be derived easily by applying  $\pi$ -symmetry. ■

LEMMA 5.9. *For the strong Hopf datum  $\mathfrak{h}$  the following identities are satisfied.*

$$\text{[Diagram 1]} = \text{[Diagram 2]}, \quad \text{[Diagram 3]} = \text{[Diagram 4]} \tag{5.16}$$

$$\text{[Diagram 5]} = \text{[Diagram 6]}, \quad \text{[Diagram 7]} = \text{[Diagram 8]} \tag{5.17}$$

$$\text{[Diagram 9]} = \text{[Diagram 10]}, \quad \text{[Diagram 11]} = \text{[Diagram 12]} \tag{5.18}$$

*Proof.* The proof follows straightforwardly from the cocycle and cycle compatibilities of Definition 4.1 and the identities (4.6) and (4.7). ■

LEMMA 5.10. *The subsequent relations involving  $\hat{\rho}$  and  $\hat{\sigma}$  hold in  $\mathfrak{h}$ .*

$$\text{[Diagram 13]} = \text{[Diagram 14]}, \quad \text{[Diagram 15]} = \text{[Diagram 16]} \tag{5.19}$$

$$\text{[Diagram 17]} = \text{[Diagram 18]}, \quad \text{[Diagram 19]} = \text{[Diagram 20]} \tag{5.20}$$

*Proof.* Because of  $\pi$ -symmetry we will only demonstrate the first identities of (5.19) and (5.20). Applying to the left hand side of (5.19) the algebra-coalgebra compatibility (for  $\Delta_2$  and  $m_2$ ) and the entwining property of  $\varphi_{2,2}$  (Lemma 5.7) yields the result.

To obtain the first identity of (5.20) we transform its left hand side consecutively using the relative bialgebra property (5.8) of  $\Delta_2$  and  $m_2$ , the comodularity of  $(B_1, \nu_l)$ , the first relation of (5.6), the first identity of (5.16), the relative associativity of  $m_2$ , and again the fact that  $(B_1, \nu_l)$  is a left comodule. ■

*Remark 14.* Note that (5.4) and (5.16) are special cases of (5.20). Furthermore (5.18) implies (4.7).

*Special Properties of Strong Hopf Data*

Before we prove Theorem 4.4 we have to provide several auxiliary definitions and specific properties of strong Hopf Data. Similarly as in Remark 6 we define  $p_1 = \text{id}_{B_1} \otimes \varepsilon_2$ ,  $p_2 = \varepsilon_1 \otimes \text{id}_{B_2}$ ,  $p_0 = \text{id}_B$ ,  $i_1 = \text{id}_{B_1} \otimes \eta_2$ ,  $i_2 = \eta_1 \otimes \text{id}_{B_2}$ , and  $i_0 = \text{id}_B$ . In this context we occasionally use the notation  $B_0 := B := B_0 \otimes B_1$ . Given a strong Hopf datum  $\mathfrak{h}$  we can build the morphisms  $m_B : B \otimes B \rightarrow B$  and  $\Delta_B : B \rightarrow B \otimes B$  like in (3.9) as

$$m_B := \text{[diagram]} \quad \text{and} \quad \Delta_B := \text{[diagram]} \tag{5.21}$$

Similarly as in (3.4) and (3.5) we define

$$m_{i,j,k} := p_i \circ m_B \circ (i_j \otimes i_k) = \text{[diagram]} \quad \text{for all } i, j, k \in \{0, 1, 2\},$$

$$\Delta_{i,j,k} := (p_i \otimes p_j) \circ \Delta_B \circ i_k = \text{[diagram]} \quad \text{for all } i, j, k \in \{0, 1, 2\},$$
(5.22)

and

$$m_{0,20}^* := \hat{\sigma} \circ (\mu_r \otimes \text{id}_{B_2}), \quad m_{l,2m}^* := p_l \circ m_{0,20}^* \circ (\text{id}_{B_2} \otimes i_m)$$

$$\Delta_{01,0}^* := (\text{id}_{B_1} \otimes \nu_l) \circ \hat{\rho}, \quad \Delta_{l1,m}^* := (p_l \otimes \text{id}_{B_1}) \circ \Delta_{01,0}^* \circ i_m$$
(5.23)

for  $l, m \in \{0, 1, 2\}$ . In particular (5.22) implies

$$m_1 = m_{1,11}, \quad \Delta_1 = \Delta_{11,1}, \quad \mu_l = m_{1,21}, \quad \nu_l = \Delta_{21,1},$$

$$m_2 = m_{2,22}, \quad \Delta_2 = \Delta_{22,2}, \quad \mu_r = m_{2,21}, \quad \nu_r = \Delta_{21,2},$$

$$m_B = m_{0,00}, \quad \Delta_B = \Delta_{00,0}, \quad \sigma = m_{1,22}, \quad \rho = \Delta_{11,2}.$$

The following morphisms

$$\left\langle \begin{matrix} kl \\ ijmn \\ rs \end{matrix} \right\rangle, \left\langle \begin{matrix} i^{kl} \\ rs \mid, \mid^{kl} j \end{matrix} \right\rangle, \left\langle \begin{matrix} 2^{kl} \\ rs \mid^*, \mid^{kl} 1 \end{matrix} \right\rangle^* : B_k \otimes B_l \rightarrow B_r \otimes B_s$$

turn out to be useful in the sequel. Let  $i, j, m, n, r, s, k, l \in \{0, 1, 2\}$ . Then

$$\begin{aligned} \left\langle \begin{matrix} kl \\ ijmn \\ rs \end{matrix} \right\rangle &:= (m_{r,im} \otimes m_{s,jn}) \circ (\text{id}_{B_i} \otimes \Psi_{B_j, B_m} \otimes \text{id}_{B_n}) \circ (\Delta_{ij, k} \otimes \Delta_{mn, l}), \\ \left\langle \begin{matrix} i^{kl} \\ rs \mid \end{matrix} \right\rangle &:= (m_{r,il} \otimes \text{id}_{B_s}) \circ (\text{id}_{B_i} \otimes \Psi_{B_s, B_l}) \circ (\Delta_{is, k} \otimes \text{id}_{B_l}), \\ \left\langle \begin{matrix} \mid^{kl} \\ rs j \end{matrix} \right\rangle &:= (\text{id}_{B_r} \otimes m_{s,kj}) \circ (\Psi_{B_k, B_r} \otimes \text{id}_{B_j}) \circ (\text{id}_{B_k} \otimes \Delta_{rj, l}), \\ \left\langle \begin{matrix} 2^{kl} \\ rs \mid^* \end{matrix} \right\rangle &:= (m_{r,2l}^* \otimes \text{id}_{B_s}) \circ (\text{id}_{B_2} \otimes \Psi_{B_s, B_l}) \circ (\Delta_{2s, k} \otimes \text{id}_{B_l}), \\ \left\langle \begin{matrix} \mid^{kl} \\ rs 1 \end{matrix} \right\rangle^* &:= (\text{id}_{B_r} \otimes m_{s,k1}) \circ (\Psi_{B_k, B_r} \otimes \text{id}_{B_1}) \circ (\text{id}_{B_k} \otimes \Delta_{r1, l}^*). \end{aligned} \tag{5.24}$$

For a strong Hopf datum  $\mathfrak{h}$  we obtain the following bra-ket decomposition of morphisms (5.24).

LEMMA 5.11.

$$\left\langle \begin{matrix} kl \\ i0mn \\ rs \end{matrix} \right\rangle = (\text{id}_{B_r} \otimes m_{s,1s}) \circ (\left\langle \begin{matrix} i^{km} \\ r1 \mid \otimes \text{id}_{B_s} \end{matrix} \right\rangle \circ (\text{id}_{B_k} \otimes \left\langle \begin{matrix} 2l \\ ms n \end{matrix} \right\rangle)) \circ (\Delta_{k2, k} \otimes \text{id}_{B_l}) \tag{5.25}$$

for any  $i, k, l, m, n, r, s \in \{0, 1, 2\}$ .

*Proof.* The lemma follows straightforwardly from the (co-)associativity of  $m_B$  and  $\Delta_B$  and the identities  $m_{0,12} = \text{id}_{B_0} = \Delta_{12,0}$ . ■

Below we define another set of auxiliary morphisms which will be used in the course of the proof of Theorem 4.4.

$$\tau_t^0 := \text{diagram 1}, \tau_t^1 := \text{diagram 2}, \tau_t^2 := \text{diagram 3}, \tau_t^3 := \text{diagram 4} \tag{5.26}$$

$$\tau_b^0 := \text{diagram 5}, \tau_b^1 := \text{diagram 6}, \tau_b^2 := \text{diagram 7}, \tau_b^3 := \text{diagram 8} \tag{5.27}$$

In addition we use the following definitions.

$$\begin{aligned}
 \sigma^{\text{tr}} &:= \text{diagram with box 22}, & \rho^{\text{tr}} &:= \text{diagram with box 11}, & (\tau_t^3)^{\text{red}_1} &:= \text{diagram with box 22}, & (\tau_b^3)^{\text{red}_1} &:= \text{diagram with box 11} \\
 (\tau_t^3)^{\text{red}_2} &:= \text{diagram with box 22}, & (\tau_b^3)^{\text{red}_2} &:= \text{diagram with box 11}, & (\tau_t^3)^{\text{red}_3} &:= \text{diagram with box 22}, & (\tau_b^3)^{\text{red}_3} &:= \text{diagram with box 11}
 \end{aligned}
 \tag{5.28}$$

Observe that the morphisms  $(\tau_t)^{\text{red}}$  and  $(\tau_b)^{\text{red}}$  in (5.28) can be expressed with the help of  $\tau_t^3$  and  $\tau_b^3$ , respectively. For instance,  $(\tau_t^3)^{\text{red}_1} = (\text{id}_{B_2} \otimes \text{id}_{B_1} \otimes \text{id}_{B_2} \otimes \varepsilon_2 \otimes \text{id}_{B_2} \otimes \text{id}_{B_1}) \circ \tau_t^3$ .

LEMMA 5.12. *For a strong Hopf datum  $\mathfrak{h}$  the following reduction identities are satisfied,*

$$\left| \begin{smallmatrix} 20 \\ i0 \end{smallmatrix} 1 \right\rangle = \left( \left| \begin{smallmatrix} 20 \\ i1 \end{smallmatrix} 1 \right\rangle \otimes \text{id}_{B_2} \right) \circ \tau_t^0, \quad \langle 1_{01}^{0i} | = \tau_b^0 \circ (\text{id}_{B_1} \otimes \langle 1_{01}^{2i} |), \tag{5.29}$$

$$\left| \begin{smallmatrix} 20 \\ i0 \end{smallmatrix} 0 \right\rangle = \left( \left| \begin{smallmatrix} 20 \\ i1 \end{smallmatrix} 0 \right\rangle \otimes \text{id}_{B_2} \right) \circ \tau_t^1, \quad \langle 0_{01}^{0i} | = \tau_b^1 \circ (\text{id}_{B_1} \otimes \langle 0_{01}^{2i} |), \tag{5.30}$$

$$\begin{aligned}
 \left| \begin{smallmatrix} 20 \\ i1 \end{smallmatrix} 0 \right\rangle &= (\text{id}_B \otimes \mathfrak{m}_1) \circ \left( \left| \begin{smallmatrix} 20 \\ i1 \end{smallmatrix} 1 \right\rangle \otimes \text{id}_{B_1} \right) \circ \tau_t^2, \\
 \langle 0_{01}^{2i} | &= \tau_b^2 \circ (\text{id}_{B_2} \otimes \langle 2_{01}^{2i} |) \circ (\Delta_2 \otimes \text{id}_B),
 \end{aligned}
 \tag{5.31}$$

$$\begin{aligned}
 \left| \begin{smallmatrix} 22 \\ i1 \end{smallmatrix} 0 \right\rangle &= (\text{id}_B \otimes \mathfrak{m}_1) \circ \left( \left| \begin{smallmatrix} 22 \\ i1 \end{smallmatrix} 1 \right\rangle \otimes \text{id}_{B_1} \right) \circ \sigma^{\text{tr}}, \\
 \langle 0_{11}^{2i} | &= \rho^{\text{tr}} \circ (\text{id}_{B_2} \otimes \langle 2_{11}^{2i} |) \circ (\Delta_2 \otimes \text{id}_B).
 \end{aligned}
 \tag{5.32}$$

*Proof.* We only consider the first identities of (5.29) and (5.30). The second identities in each row are  $\pi$ -symmetric analogues. The identities (5.31) follow from (5.29) by application of the mapping  $f \mapsto (\text{id} \otimes \mathfrak{m}_{1,02}) \circ (f \otimes \text{id}_{B_2}) \circ (\text{id} \otimes \Delta_2)$ . Relations (5.32) are special cases of (5.31) through composition with  $i_2$ . In a first step we derive (5.29) and (5.30) for the case  $i=2$ . For (5.29) we obtain

$$\left| \begin{smallmatrix} 20_1 \\ 20_1 \end{smallmatrix} \right\rangle = \text{diagram with boxes 12, 21} = \text{diagram with boxes 12, 12, 12} = \text{diagram with boxes 22, 12}
 \tag{5.33}$$

where the second equation is an immediate consequence of the relative entwining property (5.14) of  $\varphi_{1,2}$  and the third equation follows from (5.5) of Lemma 5.3 and the right module property of  $(B_2, \mu_r)$ .

To derive the first identity of (5.30) for  $i=2$  we use (5.12), the relative entwining property (5.14) of  $\varphi_{1,2}$ , (4.6) of Definition 4.3, the coassociativity of  $\Delta_2$ , and the entwining property (5.11) of  $\varphi_{2,2}$ .

Using (5.20), coassociativity of  $\Delta_2$ , and the entwining property (5.11) of  $\varphi_{2,2}$  we obtain the relations  $(\text{id}_{B_1} \otimes \tau_t^j) \circ f = (f \otimes \text{id}_{B_2}) \circ \tau_t^j$  for  $j \in \{0, 1\}$ . We set  $f := ((\Psi_{B_2, B_1} \otimes \text{id}_{B_1}) \circ (\text{id}_{B_2} \otimes \hat{\rho}) \otimes \text{id}_{B_2}) \circ (\text{id}_{B_2 \otimes B_1} \otimes \Delta_2)$ . These relations allow us to perform easily the step from  $i= 2$  to  $i= 0$ . Finally, the case  $i= 1$  will be obtained from the corresponding identities for  $i= 0$  by composition with  $\varepsilon_2$ . ■

LEMMA 5.13. *For a strong Hopf datum  $\mathfrak{h}$  the second module-coalgebra compatibility, the first comodule-algebra compatibility, and the cycle-cocycle compatibility of Definition 4.1 can be respectively converted to*

$$\begin{aligned} \hat{\rho} \circ \varphi_{2,1} &= \rho^{\text{tr}} \circ \left( \text{id}_{B_2} \otimes \left\langle \begin{array}{c} 21 \\ 2011 \\ 11 \end{array} \right\rangle \right) \circ (\Delta_2 \otimes \text{id}_{B_1}), \\ \varphi_{1,2} \circ \hat{\sigma} &= (\text{id}_{B_2} \otimes m_1) \circ \left( \left\langle \begin{array}{c} 22 \\ 2021 \\ 21 \end{array} \right\rangle \otimes \text{id}_{B_1} \right) \circ \sigma^{\text{tr}}, \\ \hat{\rho} \circ \hat{\sigma} &= (\text{id}_{B_1} \otimes m_1) \circ (\rho^{\text{tr}} \otimes \text{id}_{B_1}) \circ \left( \text{id}_{B_2} \otimes \left\langle \begin{array}{c} 22 \\ 2001 \\ 11 \end{array} \right\rangle \otimes \text{id}_{B_1} \right) \\ &\quad \circ (\text{id}_{B_2} \otimes \sigma^{\text{tr}}) \circ (\Delta_2 \otimes \text{id}_{B_2}). \end{aligned} \tag{5.34}$$

*Proof.* The morphisms on the right hand side of the corresponding compatibility relations can be decomposed with the help of (5.25). Then the reduction formulas (5.32) will be applied to the particular tensor factors. Finally we use again (5.25) to obtain the result. ■

The previous lemma leads to

LEMMA 5.14.

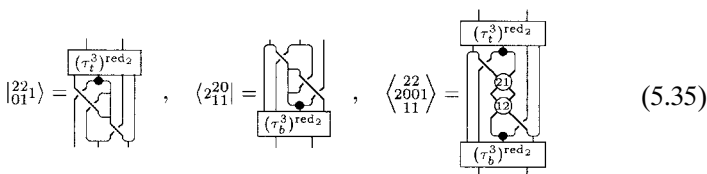

$$\left\langle \begin{array}{c} 22 \\ 011 \end{array} \right\rangle = \text{diagram}, \quad \left\langle \begin{array}{c} 20 \\ 11 \end{array} \right\rangle = \text{diagram}, \quad \left\langle \begin{array}{c} 22 \\ 2001 \\ 11 \end{array} \right\rangle = \text{diagram} \tag{5.35}$$



$$\begin{matrix} \langle 20 \\ 21 \rangle^1 = \text{diagram} \\ \langle 22 \\ 10 \rangle^1 = \text{diagram} \end{matrix}, \quad \begin{matrix} \langle 22 \\ 10 \rangle^1 = \text{diagram} \\ \langle 20 \\ 21 \rangle^1 = \text{diagram} \end{matrix} \tag{5.36}$$

$$\begin{matrix} \langle 20 \\ 01 \rangle^1 = \text{diagram} \\ \langle 22 \\ 01 \rangle^1 = \text{diagram} \end{matrix}, \quad \begin{matrix} \langle 22 \\ 01 \rangle^1 = \text{diagram} \\ \langle 20 \\ 21 \rangle^1 = \text{diagram} \end{matrix} \tag{5.37}$$

*Proof.* The first identity of (5.35) has been derived by successive application of the left module-algebra compatibility of Definition 4.1 and the relations (5.6) and (5.16). The second identity is its  $\pi$ -symmetric counterpart. To get the third identity we use (5.25), the first and the second equations of (5.35), the relations (5.17), and the module-comodule compatibility.

The first identity in (5.36) is obtained from the left module-algebra compatibility and (5.6). The identities in (5.37) are derived from (5.36) with the help of (5.20). ■

The next lemma is a straightforward implication of the previous result.

LEMMA 5.15.

$$\begin{matrix} \langle 22 \\ 2001 \rangle^1 = \text{diagram} \\ \langle 22 \\ 2221 \rangle^1 = \text{diagram} \end{matrix}, \quad \begin{matrix} \langle 22 \\ 2001 \rangle^1 = \text{diagram} \\ \langle 22 \\ 2111 \rangle^1 = \text{diagram} \end{matrix} \tag{5.38}$$

*Proof.* Both identities follow from the third identity of (5.35) using (4.6), (5.16), and (4.7). ■

LEMMA 5.16. *Given a strong Hopf datum  $\mathfrak{h}$ , then it holds*

$$\begin{matrix} \text{diagram} = \langle 22 \\ 2020 \rangle^1 \\ \text{diagram} = \langle 22 \\ 0011 \rangle^1 \end{matrix} \tag{5.39}$$

$$\begin{matrix} \hat{\sigma} = \langle 22 \\ 2020 \rangle^1 \\ \hat{\rho} = \langle 22 \\ 0011 \rangle^1 \end{matrix} \tag{5.40}$$

*Proof.* We prove the first identity of (5.39) graphically.

$$\begin{matrix} \text{diagram} = \langle 22 \\ 2000 \rangle^1 \\ \text{diagram} = \langle 22 \\ 2001 \rangle^1 \\ \text{diagram} = \langle 22 \\ 2221 \rangle^1 \\ \text{diagram} = \langle 22 \\ 2020 \rangle^1 \end{matrix} \tag{5.41}$$

The first equation in the graphic has been obtained with the help of the cycle-cocycle compatibility (Definition 4.1), (4.6), and (4.7). In the second



*Proof.* According to Proposition 2.2 the identities (2.3) have to be verified in order to prove that  $B$  is a cross product algebra. Similar  $\pi$ -symmetric procedures are needed to demonstrate that  $B$  is a cross product coalgebra.

Without difficulties the unital identities of (2.3) can be verified. The fifth relation of (2.3) has been proven in Lemma 5.8 in the first identity of (5.13). The seventh identity of (2.3) will be proven subsequently,

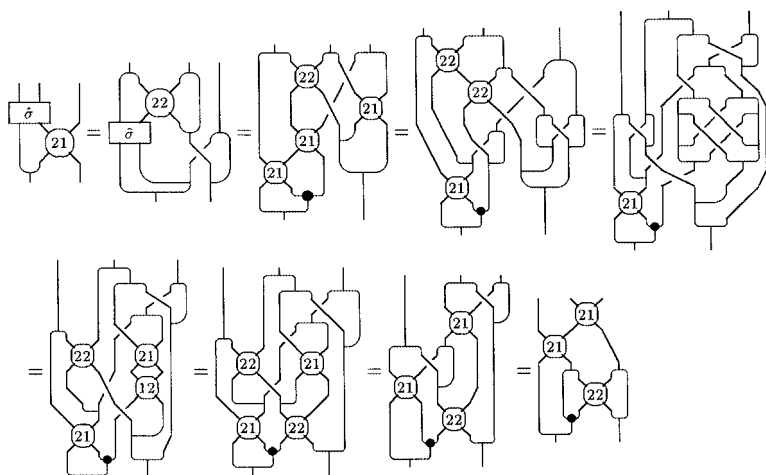

where the first identity has been obtained from (5.19). We use the weak associativity of  $\mu_l$  and the module-algebra compatibility of  $\mu_r$  according to Definition 4.1 to get the second equation in the graphic. Then the entwining property of  $\varphi_{2,2}$  (see Lemma 5.7) yields the third relation. In the fourth identity we use (5.18) and the relative coassociativity of  $\Delta_1$  corresponding to Lemma 5.2. To derive the fifth identity the module-comodule compatibility of Definition 4.1 has been used. In the sixth equation we apply (5.15), and in the seventh equation we use (5.12). Hence the seventh identity of (2.3) has been verified. Finally we will prove the sixth identity of (2.3). Its left

hand side will be transformed according to

(5.45)

where we used (5.12) and (5.19) in the first equation, and (5.40) and the right modularity of  $(B_2, \mu_r)$  in the second equation. To get the third identity in the graphic one has to apply (5.42) and again the fact that  $(B_2, \mu_r)$  is a right module. In the fourth relation we use (5.12) and the relative comodule property of  $\nu_r$  according to Lemma 5.2. The fifth identity can be verified with the help of (5.5). The module-comodule compatibility, the associativity of  $\Delta_2$ , and the entwining property (5.11) of  $\varphi_{2,2}$  yield the final equation in the graphic.

For the right hand side of the sixth identity of (2.3) we get

(5.46)

In the first equation of (5.46) we used (5.19). Then we applied (5.11) to get the second equation. To derive the third identity we make use of the cocycle

compatibility and the weak associativity of  $m_2$  according to Definition 4.1. In the fourth equation we apply the right comodule-coalgebra compatibility, and the fifth identity follows from (5.33). The sixth equation in the graphical calculation (5.46) has been obtained from the entwining property of  $\varphi_{2,2}$  and the left module-algebra compatibility.

Eventually, the seventh graphic in (5.45) and in (5.46) coincides. This can be verified by applying Lemma 5.2 for  $m_2$  and  $\nu_r$ , coassociativity of  $\Delta_2$ , the right modularity of  $(B_2, \mu_r)$ , and (5.6) of Lemma 5.4. ■

*Remark 15.* To finish the proof of Theorem 4.4 we have to show that  $\Delta_B$  is an algebra morphism. For this purpose we will use a sort of *dressing transformation* technique. This means we define two sequences of morphisms  $(\beta_\ell^i)_{i=0}^4$  and  $(\beta_r^i)_{i=0}^4$  and a sequence of “dressing transformations”  $(T^{(i)})_{i=1}^4$  where  $\beta_r^0 = (m_B \otimes m_B) \circ (\text{id} \otimes \Psi_{B,B} \otimes \text{id}) \circ (m_B \otimes m_B)$ ,  $\beta_\ell^0 = \Delta_B \circ m_B$ ,  $\beta_\ell^4 = \beta_r^4$ , and  $T^{(i)}(\beta_\ell^i) = \beta_\ell^{i-1}$ ,  $T^{(i)}(\beta_r^i) = \beta_r^{i-1}$  for all  $i \in \{1, 2, 3, 4\}$ . This implies  $\beta_\ell^0 = \beta_r^0$  and therefore the statement.

*Remark 16.* Once it is proven that  $B$  is an algebra, Proposition 2.6 provides an alternative method to show that  $\Delta_B$  is an algebra morphism. The present proof using dressing transformations is invariant under  $\pi$ -symmetry, however.

The “dressing transformations” will be defined as

$$\begin{aligned}
 T^{(1)}(f) := & \begin{array}{c} \tau_t^1 \\ \boxed{f} \\ \tau_b^1 \end{array}, \quad T^{(2)}(f) := \begin{array}{c} \tau_t^2 \\ \boxed{f} \\ \tau_b^2 \end{array}, \quad T^{(3)}(g) := \begin{array}{c} \tau_t^3 \\ \boxed{g} \\ \tau_b^3 \end{array}, \quad T^{(4)}(h) := \begin{array}{c} \tau_t^4 \\ \boxed{h} \\ \tau_b^4 \end{array}
 \end{aligned}
 \tag{5.47}$$

for any  $f \in \text{Hom}(B_{212}, B_{121})$ ,  $g \in \text{Hom}(B_{2122}, B_{1121})$ , and  $h \in \text{Hom}(B_{22122}, B_{11211})$ .

The remainder of this section is devoted to the proof of the following proposition.

**PROPOSITION 5.20.** *Given a strong Hopf datum  $\mathfrak{h}$ , then there exist two sequences of morphisms  $(\beta_\ell^i)_{i=0}^4$ ,  $(\beta_r^i)_{i=0}^4$  with  $\beta_\ell^0 := \Delta_B \circ m_B$  and  $\beta_r^0 := (m_B \otimes m_B) \circ (\text{id}_B \otimes \Psi_{B,B} \otimes \text{id}_B) \circ (\Delta_B \otimes \Delta_B)$  such that*

$$\begin{array}{ccccccc}
 \beta_\ell^0 & \xleftarrow{T^{(1)}} & \beta_\ell^1 & \xleftarrow{T^{(2)}} & \beta_\ell^2 & \xleftarrow{T^{(3)}} & \beta_\ell^3 & \xleftarrow{T^{(4)}} & \beta_\ell^4 \\
 & & & & & & & & \parallel \\
 \beta_\ell^0 & \xleftarrow{T^{(1)}} & \beta_r^1 & \xleftarrow{T^{(2)}} & \beta_r^2 & \xleftarrow{T^{(3)}} & \beta_r^3 & \xleftarrow{T^{(4)}} & \beta_r^4
 \end{array}
 \tag{5.48}$$

Therefore  $\beta_\ell^0 = \beta_r^0$  and  $B = B_1 \otimes B_2$  is a bialgebra which proves Theorem 4.4.

*Proof.* The proof will be split into several parts. At first we verify the following diagram,

$$\begin{array}{cccc}
 \beta_r^0 & \beta_r^1 & \beta_r^2 & \beta_r^3 \\
 \begin{array}{c} \text{|||} \\ \langle \begin{array}{c} 00 \\ 0000 \\ 00 \end{array} \rangle \end{array} & \begin{array}{c} \text{|||} \\ \langle \begin{array}{c} 20 \\ 0000 \\ 01 \end{array} \rangle \end{array} & \begin{array}{c} \text{|||} \\ \langle \begin{array}{c} 20 \\ 2001 \\ 01 \end{array} \rangle \end{array} & \begin{array}{c} \text{|||} \\ \langle \begin{array}{c} 20 \\ 2001 \\ 01 \end{array} \rangle \end{array} \\
 \downarrow & \downarrow & \downarrow & \downarrow \\
 \begin{array}{c} \langle \begin{array}{c} 20 \\ 00 \end{array} \rangle \\ \downarrow \\ \langle \begin{array}{c} 00 \\ 01 \end{array} \rangle \end{array} & \xleftarrow{T(1)} & \begin{array}{c} \langle \begin{array}{c} 20 \\ 01 \end{array} \rangle \\ \downarrow \\ \langle \begin{array}{c} 020 \\ 01 \end{array} \rangle \end{array} & \xleftarrow{T(2)} & \begin{array}{c} \langle \begin{array}{c} 20 \\ 01 \end{array} \rangle \\ \downarrow \\ \langle \begin{array}{c} 220 \\ 01 \end{array} \rangle \end{array} & \xleftarrow{T(3)} & \begin{array}{c} \langle \begin{array}{c} 20 \\ 01 \end{array} \rangle \\ \downarrow \\ \langle \begin{array}{c} 220 \\ 01 \end{array} \rangle \end{array} \\
 \end{array} \tag{5.49}$$

where the identities ( $\equiv$ ) in the first row are definitions and the equalities ( $=$ ) in the second row are special cases of (5.25). The morphisms in the third row will be obtained by applying  $T^{(1)}$ ,  $T^{(2)}$ , and  $T^{(3)}$  using the identities (5.30), (5.31), and (5.37), respectively.

A similar diagram can be set up for the  $(\beta_\ell^i)$ . For that we use the following auxiliary definitions

$$\gamma_t^0 := (\text{id}_{B_1} \otimes \Delta_1) \circ m_{0,20}, \quad \gamma_b^0 := \Delta_{01,0} \circ (m_1 \otimes \text{id}_{B_2}) \tag{5.50}$$

$$\begin{array}{ccc}
 \gamma_t^1 := \begin{array}{c} \text{|||} \\ \langle \begin{array}{c} 22 \\ 010 \end{array} \rangle \end{array} & , \quad \gamma_t^2 := \begin{array}{c} \text{|||} \\ \langle \begin{array}{c} 22 \\ 011 \end{array} \rangle \end{array} & , \quad \gamma_t^3 := \begin{array}{c} \text{|||} \\ \langle \begin{array}{c} 21 \\ 2001 \\ 21 \end{array} \rangle \end{array} \\
 \gamma_b^1 := \begin{array}{c} \text{|||} \\ \langle \begin{array}{c} 020 \\ 11 \end{array} \rangle \end{array} & , \quad \gamma_b^2 := \begin{array}{c} \text{|||} \\ \langle \begin{array}{c} 21 \\ 0111 \end{array} \rangle \end{array} & , \quad \gamma_b^3 := \begin{array}{c} \text{|||} \\ \langle \begin{array}{c} 21 \\ 2001 \\ 21 \end{array} \rangle \end{array} \\
 \end{array} \tag{5.51}$$

Then

$$\begin{array}{cccc}
 \beta_\ell^0 & \beta_\ell^1 & \beta_\ell^2 & \beta_\ell^3 \\
 \text{|||} & \text{|||} & \text{|||} & \text{|||} \\
 \Delta_0 \circ m_0 & \Delta_{01,0} \circ m_{0,20} & & \\
 \downarrow & \downarrow & \downarrow & \downarrow \\
 \begin{array}{c} \langle \gamma_t^0 \rangle \\ \downarrow \\ \langle \gamma_b^0 \rangle \end{array} & \xleftarrow{T(1)} & \begin{array}{c} \langle \gamma_t^1 \rangle \\ \downarrow \\ \langle \gamma_b^1 \rangle \end{array} & \xleftarrow{T(2)} & \begin{array}{c} \langle \gamma_t^2 \rangle \\ \downarrow \\ \langle \gamma_b^2 \rangle \end{array} & \xleftarrow{T(3)} & \begin{array}{c} \langle \gamma_t^3 \rangle \\ \downarrow \\ \langle \gamma_b^3 \rangle \end{array} \\
 \end{array} \tag{5.52}$$

Again the identities ( $\equiv$ ) in the first row are definitions. The remaining identities will be proven in the subsequent lemmas.

LEMMA 5.21.

$$\gamma_t^0 = (m_{0,20} \otimes \text{id}_{B_2}) \circ \tau_t^1, \quad \gamma_b^0 = \tau_b^1 \circ (\text{id}_{B_1} \otimes \Delta_{01,0}) \tag{5.53}$$

and hence  $\beta_\ell^0 = T^{(1)}(\beta_\ell^1)$ .

*Proof.* The identities are obtained using (5.19) and (5.12).

LEMMA 5.22.

$$\beta_\ell^1 = (\text{id} \otimes m_1) \circ (\gamma_b^1 \otimes \text{id}_{B_1}) \circ (\text{id}_{B_2} \otimes \gamma_t^1) \circ (\Delta_2 \otimes \text{id}) \tag{5.54}$$

$$\gamma_t^1 = (\text{id} \otimes m_1) \circ (\gamma_t^2 \otimes \text{id}_{B_1}) \circ \tau_t^2, \tag{5.55}$$

$$\gamma_b^1 = \tau_b^2 \circ (\text{id}_{B_2} \otimes \gamma_b^2) \circ (\Delta_2 \otimes \text{id})$$

and therefore  $\beta_\ell^1 = T^{(2)}(\beta_\ell^2)$ .

*Proof.* The proof of the identity (5.54) will be given in the following graphical calculation,

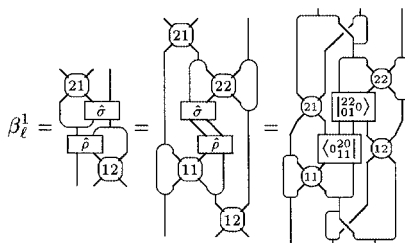

where the first equation holds by definition and the second identity is an application of (5.19). In the third equation we use the cycle-cocycle compatibility, (5.25), the (co-)associativity of  $m_1$  and  $\Delta_2$ , and (5.12).

To prove the first identity of (5.55) we transform in the next calculation the morphism  $\gamma_t^1$  with the help of (5.32), the entwining properties (5.11) of  $\varphi_{2,2}$ , and (5.12) of  $\varphi_{1,2}$ .

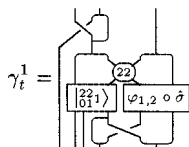

From the right hand side of this equation we get the right hand side of (5.55) by applying (5.34) and again the entwining property (5.11) of  $\varphi_{2,2}$ . ■

LEMMA 5.23.

$$\gamma_t^2 = \begin{array}{c} \text{---} \\ \text{---} \\ \tau_t^3 \\ \text{---} \\ \gamma_t^3 \\ \text{---} \\ \text{---} \end{array}, \quad \gamma_b^2 = \begin{array}{c} \text{---} \\ \text{---} \\ \gamma_b^3 \\ \text{---} \\ \tau_t^3 \\ \text{---} \\ \text{---} \end{array} \quad (5.56)$$

and therefore  $\beta_\ell^2 = T^{(3)}(\beta_\ell^3)$ .

*Proof.* The following identities hold.

$$\begin{array}{c} \begin{array}{c} \langle 22 \rangle \\ \langle \begin{smallmatrix} 221 \\ 01 \end{smallmatrix} \rangle \\ \langle \begin{smallmatrix} 222 \\ 21 \end{smallmatrix} \rangle \end{array} \\ B \quad B_2 \quad B_1 \end{array} = \begin{array}{c} \langle 02|2 \rangle \\ \langle \begin{smallmatrix} 21 \\ 2001 \\ 21 \end{smallmatrix} \rangle \\ B \quad B_2 \quad B_1 \end{array}, \quad \gamma_t^2 = \begin{array}{c} (\tau_t^3)^{\text{red}_1} \\ \langle 02|2 \rangle \\ \langle \begin{smallmatrix} 21 \\ 2001 \\ 21 \end{smallmatrix} \rangle \\ B_1 \quad B \quad B_2 \quad B_1 \end{array} \quad (5.57)$$

The first identity of (5.57) is a consequence of (5.44) and the module-comodule compatibility. Using this result we obtain the second relation in (5.57) with the help of (5.25) and the entwining property (5.11) of  $\varphi_{2,2}$ .

We denote

$$\tau_t^4 := \begin{array}{c} \text{---} \\ \text{---} \\ \langle 22 \rangle \\ \text{---} \\ \text{---} \end{array} \quad (5.58)$$

Then we obtain

$$\begin{array}{c} \langle 02|2 \rangle \\ \langle \begin{smallmatrix} 21 \\ 2001 \\ 21 \end{smallmatrix} \rangle \\ B_1 \quad B \quad B_2 \quad B_1 \end{array} = \begin{array}{c} \tau_t^4 \\ \gamma_t^3 \\ \text{---} \\ \text{---} \end{array}, \quad \tau_t^3 = \begin{array}{c} (\tau_t^3)^{\text{red}_1} \\ \tau_t^4 \\ \text{---} \\ \text{---} \end{array} \quad (5.59)$$

The first equation in (5.59) results from the algebra-coalgebra compatibility, the right comodule-algebra compatibility, the left module-algebra compatibility, (5.6), (5.16), and the right module algebra property of  $B_2$ . The second identity can be obtained by subsequent application of the right comodule-coalgebra compatibility, the left module-algebra compatibility, (5.6), the right module-coalgebra property of  $B_2$ , and the entwining property of  $\varphi_{2,2}$ .



The first relation of (5.56) can now be derived by recursive substitution of the identities (5.59) into the second identity of (5.57). ■

Eventually we define

$$\beta_\ell^4 := \text{[Diagram]} \quad \text{and} \quad \beta_r^4 := \text{[Diagram]} \quad (5.60)$$

In what follows we will tacitly use the various forms of (weak) (co-)associativity of  $m_1, m_2, \Delta_1, \Delta_2, \mu_l, \mu_r, \nu_l$ , and  $\nu_r$  which are given by Lemma 5.2 in particular. The subsequent graphical calculation yields  $\beta_\ell^3 = T^{(4)}(\beta_\ell^4)$ ,

$$\beta_\ell^3 = \text{[Diagram]} = \text{[Diagram]} = \text{[Diagram]} = T^{(4)}(\beta_\ell^4)$$

where we used the module-comodule compatibility and (5.6) in the first equation. In the second identity we use again (5.6). To get the third equation in the graphic we applied the right module-algebra and the left comodule-coalgebra compatibilities of Definition 4.1 as well as (5.17). With the help of the module-comodule compatibility the fourth identity can be derived from the definition of  $\beta_\ell^4$  in (5.60) and the definition of  $T^{(4)}$  in (5.47).

Next we will prove the identity  $\beta_r^3 = T^{(4)}(\beta_r^4)$ . Therefore all relations in both rows of the diagram in Proposition 5.20 are satisfied.

$$\beta_r^3 = \quad = \quad = \quad = T^{(4)}(\beta_r^4)$$

The first identity in this graphical calculation has been obtained from (5.9) and (5.10) of Lemma 5.6. In the second equation we use (5.7), Lemma 5.5, and (5.8). With the help of the left module-algebra and right comodule-coalgebra compatibilities of Definition 4.1 and the relativizations (5.9) and (5.10) of Lemma 5.6 we derive the third identity. The fourth equation holds by definition.

In order to complete the proof of the proposition the equation  $\beta_\ell^4 = \beta_r^4$  needs to be shown. This will be done in the following calculation,

$$\beta_\ell^4 = \quad = \quad = \quad = \beta_r^4$$

where the first equation has been derived with the help of (4.6). In the second and the third equations we use (5.6) and (5.7). Finally we apply (4.8) to obtain the fourth identity.

Hence Proposition 5.20 and therefore Theorem 4.4 has been proven.  $\blacksquare$

## REFERENCES

1. N. Andruskiewitsch and J. Devoto, Extensions of Hopf algebras, *St. Petersburg Math. J.* **7**, No. 1 (1996), 17–52.
2. Yu. N. Bespalov, Crossed modules and quantum groups in braided categories, *Appl. Categ. Structures* **5**, No. 2 (1997), 155–204; Yu. N. Bespalov, Crossed modules, quantum braided groups and ribbon structures, *Teoret. Mat. Fiz.* **103**, No. 3 (1995), 368–387.
3. Yu. N. Bespalov and B. Drabant, Hopf (bi-)Modules and crossed modules in braided categories, *J. Pure Appl. Algebra* **123** (1998), 105–129.
4. Yu. N. Bespalov and B. Drabant, Differential calculus in braided tensor categories, preprint, q-alg/9703036, 1997; Yu. N. Bespalov and B. Drabant, Bicovariant differential calculi and cross products on braided Hopf algebras, in “Proceedings, Quantum Groups and Quantum Spaces, 1995” (R. Budzynski *et al.*, Eds.), Banach Center Publications, Vol. 40, Institute of Math., Polish Acad. Sci., Warsaw, 1997.
5. Yu. N. Bespalov and B. Drabant, Cross product bialgebras—Part I, *J. Algebra* **219** (1999), 466–505.
6. Yu. N. Bespalov and B. Drabant, Cross product bialgebras—Part III, preprint, DAMTP-98-134, 1998.
7. R. J. Blattner, M. Cohen, and S. Montgomery, Crossed products and inner actions of Hopf algebras, *Trans. Amer. Math. Soc.* **298** (1986), 671–711.
8. T. Brzezinski, Crossed products by a coalgebra, *Comm. Algebra* **25**, No. 11 (1997), 3551–3575.
9. S. Caenepeel, B. Ion, G. Militaru, and S. Zhu, The factorization problem and the smash biproduct of algebras and coalgebras, *Algebras Represent. Theory* **3** (2000), 19–42.
10. A. Connes and H. Moscovici, Hopf algebras, cyclic cohomology and the transverse index theorem, *Comm. Math. Phys.* **198** (1998), 199–246.
11. H.-X. Chen and S. Zhang, The double biproduct in braided tensor categories, Preprint, 1998.
12. Y. Doi and M. Takeuchi, Cleft comodule algebras for a bialgebra, *Comm. Algebra* **14** (1986), 801–818.
13. P. Freyd and D. Yetter, Braided compact closed categories with applications to low dimensional topology, *Adv. Math.* **77** (1989), 156–182; P. Freyd and D. Yetter, Coherence theorems via knot theory, *J. Pure Appl. Algebra* **78** (1992), 49–76.
14. I. Hofstetter, “Erweiterungen von Hopf-Algebren und ihre kohomologische Beschreibung,” Ph.D. thesis, Universität München, 1990; I. Hofstetter, Extensions of Hopf algebras and their cohomological description, *J. Algebra* **164** (1994), 264–298.
15. A. Joyal and R. Street, Braided tensor categories, *Adv. Math.* **102** (1993), 20–78; A. Joyal and R. Street, Braided tensor categories, Macquarie Math. Reports, No. 860081, 1986.
16. C. Kassel, “Quantum Groups,” Grad. Texts in Math., Vol. 155, Springer-Verlag, New York/Berlin, 1995.
17. V. V. Lyubashenko, Tangles and Hopf algebras in braided categories, *J. Pure Appl. Algebra* **98** (1995), 245; V. V. Lyubashenko, Modular transformations for tensor categories, *J. Pure Appl. Algebra* **98** (1995), 279.
18. S. Majid, Physics for algebraists: Non-commutative and non-cocommutative Hopf algebras by a bicrossproduct construction, *J. Algebra* **130** (1990), 17–64.
19. S. Majid, Braided Groups, *J. Pure Appl. Algebra* **86** (1993), 187.
20. S. Majid, More examples of bicrossproduct and double cross product Hopf algebras, *Israel. J. Math.* **72** (1990), 133–148.
21. S. Majid, Double-bosonization of braided groups and the construction of  $U_q(g)$ , *Math. Proc. Cambridge Philos. Soc.* **125** (1999), 151–192.

22. S. Majid and Ya. S. Soibelman, Bicrossproduct structure of the quantum Weyl group, *J. Algebra* **163** (1994), 68–87.
23. S. Montgomery, “Hopf Algebras and Their Actions on Rings,” CBMS, Vol. 82, Amer. Math. Soc., Providence 1992.
24. D. E. Radford, The structure of Hopf algebras with a projection, *J. Algebra* **92** (1985), 322.
25. N. Yu. Reshetikhin and V. G. Turaev, Ribbon graphs and their invariants derived from quantum groups, *Comm. Math. Phys.* **127** (1990), 1.
26. P. Schauenburg, The structure of Hopf algebras with a weak projection, preprint, (1998).
27. H.-J. Schneider, Hopf Galois extensions, crossed products, and Clifford theory, in “Advances in Hopf Algebras” (J. Bergen and S. Montgomery, Eds.), Lecture Notes in Pure Appl. Math., Vol. 158, pp. 267–297, Dekker, New York, 1994.
28. W. M. Singer, Extension theory for connected Hopf algebras, *J. Algebra* **21** (1972), 1–16.
29. M. E. Sweedler, Cohomology of algebras over Hopf algebras, *Trans. Amer. Math. Soc.* **133** (1968), 205–239.
30. M. Takeuchi, Matched pairs of groups and bismash products of Hopf algebras, *Comm. Algebra* **9** (1981), 841–882.
31. V. G. Turaev, “Quantum Invariants of Knots and 3-Manifolds,” Studies in Mathematics, Vol. 18, de Gruyter, Berlin/New York, 1994.