

Association of Hereditary Nonpolyposis Colorectal Cancer–Related Tumors Displaying Low Microsatellite Instability with *MSH6* Germline Mutations

Ying Wu,¹ Maran J. W. Berends,² Rob G. J. Mensink,¹ Claudia Kempinga,³ Rolf H. Sijmons,¹ Ate G. J. van der Zee,⁴ Harry Hollema,³ Jan H. Kleibeuker,² Charles H. C. M. Buys,¹ and Robert M. W. Hofstra¹

Departments of ¹Medical Genetics, ²Gastroenterology, ³Pathology, and ⁴Gynaecology, University of Groningen, Groningen, The Netherlands

Summary

Hereditary nonpolyposis colorectal cancer (HNPCC) (Amsterdam criteria) is often caused by mutations in mismatch repair (MMR) genes, and tumors of patients with HNPCC show microsatellite instability (MSI-high phenotype). Germline mutations of MMR genes have rarely been found in families that have HNPCC or suspected HNPCC and that do not show microsatellite instability (MSI-low phenotype). Therefore, an MSI-high phenotype is often used as an inclusion criterion for mutation testing of MMR genes. Correction of base-base mismatches is the major function of *MSH6*. Since mismatches present with an MSI-low phenotype, we assumed that the phenotype in patients with HNPCC-related tumors might be associated with *MSH6* germline mutations. We divided 36 patients with suspected HNPCC into an MSI-low group ($n = 18$) and an MSI-high group ($n = 18$), on the basis of the results of MSI testing. Additionally, three unrelated patients from Amsterdam families with MSI-low tumors were investigated. All patients were screened for *MSH2*, *MLH1*, and *MSH6* mutations. Four presumably causative *MSH6* mutations were detected in the patients (22%) who had suspected HNPCC and MSI-low tumors. Furthermore, we detected one frameshift mutation in one of the three patients with HNPCC and MSI-low tumors. In the MSI-high group, one *MSH6* missense mutation was found, but the same patient also had an *MLH1* mutation, which may explain the MSI-high phenotype. These results suggest that *MSH6* may be involved in a substantial proportion of patients with HNPCC or suspected HNPCC and MSI-low tumors. Our data emphasize that an MSI-low phenotype cannot be considered an exclusion criterion for mutation testing of MMR genes in general.

Received March 1, 1999; accepted August 24, 1999; electronically published October 5, 1999.

Address for correspondence and reprints: Dr. Robert M. W. Hofstra, Department of Medical Genetics, Antonius Deusinglaan 4, 9713 AW Groningen, The Netherlands. E-mail: R.M.W.Hofstra@med.rug.nl

© 1999 by The American Society of Human Genetics. All rights reserved. 0002-9297/1999/6505-0011\$02.00

Introduction

Hereditary nonpolyposis colorectal cancer (HNPCC [MIM 120435 and MIM 120436]) is an autosomal dominant disorder in which, in addition to colon cancer, tumors also occur in the endometrium, small bowel, pancreas, biliary tract, stomach, ovary, and urinary tract. Diagnosis of HNPCC is defined by the so-called Amsterdam criteria (Vasen et al. 1991): occurrence of histologically verified colorectal cancer (CRC) in at least three relatives (one of whom is a first-degree relative of the other two) in at least two successive generations and an age of <50 years at onset of CRC in one of the relatives. Furthermore, familial adenomatous polyposis should be excluded. Among all patients with CRC, however, only 1%–2% meet these strict criteria (Aaltonen et al. 1998). A substantial proportion of the tumors in the patients not meeting these strict criteria and in whom familial polyposis is excluded might be called “suspected HNPCC,” since several, but not all, of the criteria are met.

Almost all tumors of patients with HNPCC demonstrate microsatellite instability (MSI). MSI is the result of such somatic frameshift mutations as small deletions or insertions. These mutations are caused by a defective DNA repair system (Aaltonen et al. 1993; Peltomäki et al. 1993). To date, germline mutations of five MMR genes (*MSH2*, *MLH1*, *PMS1*, *PMS2*, and *MSH6* [also designated “*GTBP*”]) have been identified in patients with HNPCC (Akiyama et al. 1997; Miyaki et al. 1997; Peltomäki et al. 1997). It has been shown that the large majority of germline mutations found in families with HNPCC that fulfill the Amsterdam criteria are detected in *MSH2* or *MLH1* (Liu et al. 1996; Nyström-Lahti et al. 1996), both of which encode MMR enzymes that are mainly involved in the repair of small insertions/deletions.

Germline mutations of MMR genes have rarely been found in families that do not meet these criteria and that display MSI-low tumors. This might point to involvement of a tumor-suppressor gene in such families. Indeed, a germline mutation of the *TGF β R2* gene, which

encodes transforming growth factor- β , was recently detected in a family with suspected HNPCC and an MSI-low tumor phenotype (Lu et al. 1998). The importance of transforming growth factor- β in tumorigenesis is already known, since somatic frameshift mutations at an (A)₁₀ repeat in the gene are frequently found in HNPCC-associated tumors with an MSI-high phenotype (Markowitz et al. 1995). Nevertheless, the genes that are responsible for a majority of cases of HNPCC and suspected HNPCC in families with MSI-low tumors are unknown.

As an alternative to tumor-suppressor-gene involvement, MMR genes such as *MSH6* (Drummond et al. 1995), which encode enzymes involved in the repair of base-base mismatches, cannot be excluded from playing a role in these families. Investigations in yeast and in human cells have revealed that *MSH6* is essential for MMR and is involved in repair of single-nucleotide mismatches (Drummond et al. 1995; Palombo et al. 1995). Interestingly, tumors in *MSH6* knockout mice display an MSI-low phenotype (Edelmann et al. 1997). To test a possible involvement of *MSH6* in patients with MSI-low tumors, we used two-dimensional DNA electrophoresis to scan *MSH6* (for cDNA sequence, see GenBank accession number U28946; for exon and intron boundaries, see GenBank accession numbers U73732–U73737), as well as *MSH2* and *MLH1*, for germline mutations in three unrelated patients who had MSI-low tumors and were from families fulfilling the Amsterdam criteria and in 36 patients with suspected HNPCC, who were divided, according to the results of MSI testing, into an MSI-low group ($n = 18$) and an MSI-high group ($n = 18$) (see the Patients and Methods section, below).

Patients and Methods

Patients

Patients were included in the study if they fulfilled at least one of the following criteria: (1) diagnosis of CRC or endometrial cancer at age <50 years; (2) diagnosis of any HNPCC-associated tumor (gastric, small bowel, ovarian, urothelial, pancreatic, or bile duct) and a first-degree relative with a diagnosis of CRC or endometrial cancer, or vice versa, with one of the individuals receiving such a diagnosis at age <50 years; and (3) diagnosis of more than one HNPCC-associated cancer, irrespective of patient age. These were the inclusion criteria for our prospective population-based study of the occurrence of germline MMR gene mutations in individuals with suspected HNPCC. The patients in the present study represent the first 21 patients consecutively included in that study plus 15 consecutive patients who were seen at the Department of Medical Genetics, University of

Groningen, Groningen, The Netherlands, for suspected HNPCC but who did not fulfill the original Amsterdam criteria for HNPCC. In addition, three patients who had MSI-low tumors and were from families meeting the Amsterdam criteria were included.

MSI

MSI criteria and primers that were used were recently defined at an international workshop on HNPCC in Bethesda (Boland et al. 1998). They include two mononucleotide repeats (BAT25 and BAT26) and three dinucleotide repeats (D2S123, D5S346, and D17S250). DNA was extracted from formalin-fixed paraffin-embedded sections of dissected tumor tissues, as described elsewhere (Goelz et al. 1985), and from peripheral-blood lymphocytes. PCR products were analyzed, on 6% denaturing polyacrylamide gels, with the use of an A.L.F. DNA sequencer (Pharmacia LKB.). For data analysis, a DNA-fragment analyzer (Pharmacia) was used. Tumors were classified as MSI-high when two or more of the five markers showed instability or as MSI-low when none of the markers—or only one marker—showed instability.

To distinguish microsatellite-stable (MSS) from MSI-low tumors in patients with germline *MSH6* mutations, 10 additional markers were evaluated (Edwards et al. 1992; Chen et al. 1995; Parsons et al. 1995; Dietmaier et al. 1997; Boland et al. 1998). These included three mononucleotide repeats (BAT40, 52H10, and BAT17), five dinucleotide repeats (D1S158, D10S197, D13S153, D18S58, and D18S69), one trinucleotide repeat (FABP2), and one tetranucleotide repeat (D15S1232). BAT17 is a poly(A)₁₇ tract localized in the acceptor-splice site of exon 10 of the *MSH6* gene. PCR amplification of BAT17 was performed with the use of primers 5'-GGAAGGGATGATGCACTATG-3' and 5'-GTTTATAGATCATAATGTT-3'.

Using these 10 additional markers, we classified tumors either as MSI-high, when ≥ 5 (33%) of the 15 markers showed MSI, or as MSI-low, when <5 markers showed MSI. MSS tumors were characterized by the absence of instability in all 15 microsatellite loci tested.

Mutation Analysis

Mutation analysis of *MSH2*, *MLH1*, and *MSH6* was performed by means of two-dimensional DNA electrophoresis (Wu et al. 1996). For *MSH2* and *MLH1*, the analysis was performed as described elsewhere (Wu et al. 1997). The primers used for amplification of all 10 exons of the *MSH6* gene are listed in table 1, along with the fragment sizes, melting temperatures, PCR annealing temperatures, and multiplex PCR groups that were used. Exon 1 was divided into two amplicons, which were

amplified separately because of their exceptionally high GC content. Primers were designed to jointly encompass all exons plus intron-exon boundaries, with the exception of the acceptor-splice site of exon 10, where the nature of the flanking intronic sequences did not allow the design of primers for denaturing gradient gel electrophoresis (DGGE). This splice site was analyzed by means of direct sequencing.

Multiplex PCR was performed on 400 ng DNA in a total volume of 50 μ l. The PCR mixture contained 1 \times *Taq* reaction buffer, 1 mM MgCl₂, 0.5 U *Taq* DNA polymerase (HT Biotechnology), 0.75 mM each dNTP, and 10 pmol each primer. A step-down PCR program was used for multiplex PCR. The PCR profile consisted of denaturation at 94°C for 3 min; then 5 cycles each for 1 min at 94°C, 1 min at 56°C, and 2 min at 72°C;

Table 1**Oligonucleotides Used for Amplification and Two-Dimensional DNA Analysis of the *MSH6* Gene**

Exon	Primers (5'→3')	Size (bp)	Melting Temperature (°C)	Annealing Temperature (°C)	Multiplex PCR
1a	[40GC] TCCGTCCGACAGAACGGTTG TTCGCGTGAGGCCCTGGCCGA	208	79	58	
1b	CGCTGAGTGATGCCAACAAAG [55GC] CAACCCCTGTGCGAGCCTC	355	84	58	
2	AACTAAGTTATGTATTCCT [40GC] CCTGTCTGTCTGTTTCTCTC	334	72	50	d
3a	[40GC] GAACTGCTGGGATTACAGTC GTATTCAGGCTTTGCACTG	170	66	52	a
3b	[40GC] ttttttttCCCAGAAGGGAGGTCATTTT cgcccCCCCATCACCCCTAACATAAA	255	72	52	d
4a	[40GC] CCAAATTTTGATTGTTTTT CCACATCAGAGCCACCAATG	247	69	50	f
4b	cgcccCGAAGGGTCATATCAGATTC [40GC] ttttttttATACCAAACAGTAGGGCGAC	412	72	55	b
4c	CGTTAGTGGAGGTGGTGATG [40GC] tttttttt ATGAATACCAGCCCCAGTTC	353	70	55	c
4d	CTGTACCACATGGATGCTCT [40GC] CTTCCTCTTTTTCTTTGAGG	381	71	52	e
4e	CCTCTGAGAACTACAGTAAG [40GC] CCAAACTGGGAGCCGGGTA	333	68	52	c
4f	CTGTTCTCTTCAGGAAGGTC [40GC] AGCCATTGATAAAAAGCTCCT	311	70	52	f
4g	[40GC] CCTCAAAAATGCCTTATTG AGCCATTGCTTTAGGAGCCG	304	69	52	g
4h	ACTTGCCATACTCCTTTTGG [40GC] TCCAGAGCAGAAAAGAAAATC	339	70	50	b
4i	[40GC] CTACATACAGCAAGAAGAAG CCTGCTTTGGGAGTAATAAG	293	68	52	e
4j	[40GC] GAAAAGGCTCGAAAGACTGG TCGTTTACAGCCCTTCTTGG	301	71	52	a
4k	[40GC] GAAGAATACGAGTTGAAATC GCACTACTTATCAAAGCCTG	284	70	52	d
5a	[40GC] AAAACCCCAAAACGATGAAG GTCTTCGTAATGCAAGGATG	220	72	52	c
5b	[40GC] ttttttttCTTAGAGCTTAAAGGATCAC cgcccCTTTCTGATAACAAAACCTT	263	69	52	g
6	cgcccGTTTATGAAACTGTTACTACC [40GC] GCAAATATCTTTTATCACAT	282	70	52	a
7	[40GC] GAGTATTCATTTGTGATTTT CGCCCATGTTTTAAGATAGTCTTC	211	66	50	g
8	[40GC] CCTTTTTGTTTTAATTCTCT CAACAGAAGTGCCCTCTCAA	308	67	52	b
9	TTTTGAGAGGGCACTTCTGT [40GC] CCCCTTTFACTGTTTCTTTG	365	68	52	f
10	ATTTTAAGGGAAGTTTGCC [40GC] GTTTATTAGATCATAATGTT	206	68	50	e
10s ^a	GGAAGGGATGATGCACTATG GTTTATTAGATCATAATGTT	218		52	

^a The acceptor-splice site of exon 10 of *hMSH6* is analyzed by direct sequencing.

Table 2**MSI of Tumors from Patients with Germline *MSH6* Mutations**

PATIENT (TUMOR) ^a	STATUS OF MICROSATELLITE LOCUS ^b														
	BAT25	BAT26	BAT40	BAT17	52H10	D1S158	D2S123	D5S346	D10S197	D13S153	D17S250	D18S58	D18S69	FABP2	D15S1232
D840 (EC)	-	-	-	+	-	-	±	-	-	-	-	+	+	-	-
D716 ^c (CRC)	-	-	-	-	-	-	-	-	-	-	-	+	-	-	-
HNPCC49 (EC)	-	-	-	-	-	-	-	-	-	-	-	-	-	-	-
HNPCC49 (CRC)	-	-	-	-	-	-	-	-	-	-	-	-	-	-	-
D805 (CRC)	-	-	-	-	-	-	+	-	-	-	-	-	-	-	-
Div448 (EC)	-	-	±	+	-	-	+	+	-	ND	+	+	-	-	-
Div682 (CRC)	-	-	+	-	-	-	-	-	-	-	-	-	-	-	-

^a CRC = colorectal carcinoma; EC = endometrial carcinoma.

^b A minus sign (-) denotes that the individual is MSI negative; a plus sign (+), MSI positive; a plus/minus sign (±), possible MSI positive; ND, not determined.

^c Patient from family meeting the Amsterdam criteria.

then 5 cycles each for 1 min at 94°C, 1 min at 53°C, and 2 min at 72°C; and then 25 cycles each for 1 min at 94°C, 1 min at 50°C, and 2 min at 72°C. Elongation was for 5 min at 72°C. The exon 1 fragments were amplified separately in a 50- μ l reaction mixture containing 100 ng genomic DNA, 0.25 mM each dNTP, 10 pmol each primer, and 0.125 U *Taq* DNA polymerase. To increase the amount of heteroduplex molecules, a heteroduplex step was performed after PCR amplification—that is, the samples underwent a denaturation step for 10 min at 96°C, followed by renaturation for 1 h at 50°C.

For mutation analysis of *MSH6*, PCR products were mixed in equal amounts, were ethanol precipitated, and then were redissolved. A 30- μ l mixture of the amplified exons was first subjected to size separation in a 0.75-mm-thick 9% polyacrylamide (PAA) gel (acrylamide: bisacrylamide 37.5:1) in 0.5 \times TAE (1 \times TAE = 40 mM Tris, HAC pH 8.0, 20 mM NaAc, 1 mM Na₂EDTA) at 200 V/19 cm and 50°C for 5 h. The separation pattern was visualized with the use of ethidium bromide (EtBr) staining for 10 min and with UV transillumination of the gel, which was lying on a glass plate to protect the DNA fragments from damage caused by UV light. The 100–600-bp region in the middle part of the lane was cut out and was applied to a 1-mm-thick 9% PAA gel containing a denaturing gradient of 30%–60% urea-formamide (UF) (100% UF contains 7 M urea and 40% deionized formamide) and a 0%–7% glycerol gradient. Two-dimensional DNA electrophoresis was performed, at 110 V/19 cm, for 17 h at 56°C. After the DNA was stained with EtBr, the gel pattern was documented.

Fragments of exon 1 were applied to a 0.75-mm-thick 9% PAA gel containing a combined denaturing gel (Wu et al. 1999). This gel consisted of a constant denaturant gel electrophoresis part in the lower 10 cm of the gel (78% UF denaturant) and a DGGE part in the upper 9 cm of the gel (30%–78% UF). The DNA was run at 150 V/19 cm for 10 h at 60°C.

Sequencing of Amplified Fragments

Variants were confirmed by direct sequencing of independently amplified PCR products, in both sense and antisense directions, by use of the same primers that were used for DGGE (without the GC-clamp). Sequencing was performed with an ABI PRISM 377 DNA sequencer (PE Biosystems).

Results*MSI*

Two tumors from the three unrelated patients with HNPCC did not display any instability at the five tested loci. The tumor from the third patient exhibited instability at one locus (D5S346). Of the 36 patients with suspected HNPCC, 15 had tumors that did not display any instability at the five tested loci. Tumors from three patients exhibited instability at one locus (BAT25, D2S123, and D5S346). Tumors from the other 18 patients with suspected HNPCC displayed an MSI-high phenotype; tumors from 13 of these patients showed MSI in more than three tested markers.

To distinguish MSS from MSI-low tumors in the five patients (families) with germline *MSH6* mutations and MSI-low/MSS tumors, 10 additional markers were used for the MSI analysis (table 2). Neither patient HNPCC49-1 nor patient HNPCC49-2, two patients from the same family with suspected HNPCC, displayed any instability at the 15 tested markers. Tumors from the index patients of families Div682 and D805 displayed instability at a single locus (BAT40 and D2S123, respectively), whereas tumor DNA from patient D840 displayed instability at four loci (BAT17, D2S123, D18S58, and D18S69). Tumor DNA from patient D716, who had HNPCC, displayed instability at a single locus (D18S58). Tumor DNA from index patient Div 448, who had an MSI-high phenotype, was also tested for the additional 10 markers. Instability was detected at 6 (BAT 40, BAT17,

D2S123, D5S346, D17S250, and D18S58) of the 15 loci tested. Addition of the 10 extra microsatellite markers did not change the MSI status of any of the patients analyzed.

Mutation Analysis

In one of the three index patients from the Amsterdam families, a frameshift mutation (217insT) was detected in exon 4 (table 3). Since this mutation results in a premature stop codon leading to a protein that is 1,143 amino acids shorter than the wild-type gene product, we consider it to be pathogenic. No mutations were detected in the remaining two index patients.

In the 18 patients with suspected HNPCC and MSI-low tumors, four presumably pathogenic germline *MSH6* mutations were detected (table 3). In two of the index patients, the mutation was the same frameshift mutation (217insT) detected in the patient from the Amsterdam family. In both patients, the mutation appeared to be homozygously present when the fragment with a forward primer located 62 bp upstream from the intron-exon boundary of exon 4 was analyzed. However, when a forward primer that was 54 bp upstream from the intron-exon boundary was chosen, the frameshift mutation was present in a heterozygous state. The apparent homozygous state of the mutations in the first analysis is due to an intronic mutation that is located in the first forward primer-recognition site and that results in amplification of only the mutant allele. In the pedigree of one of the patients, the same frameshift mutation was also present in another individual with colon cancer (fig. 1). The presence of the 217insT mutation in two unrelated patients with suspected HNPCC and in one patient with HNPCC might indicate a founder origin. Haplotype analysis was performed with the use of four intragenic informative single-nucleotide polymorphisms (SNPs) located in exons 2–4 and 7 of the *MSH6* gene. A common haplotype was found in all three patients, making a founder effect likely (data not shown). In the third index patient, a Gln1258 stop mutation was found in exon 8 (fig. 2B). This results in a presumably path-

ogenic truncated protein that is 102 amino acids shorter than the wild-type gene product. In the fourth index patient, a missense mutation (Ser144Ile) was detected in exon 2. This mutation might be considered pathogenic, since it results in a substitution of amino acids belonging to different polarity groups and since it is located in a conserved codon (Corradi et al. 1996). Furthermore, this mutation was not present in 200 control individuals. The four mutations account for 22% of the unrelated patients with MSI-low tumors who were investigated. In addition to these mutations, an insertion of 10 nucleotides (ctgaccttaa) was found at +43 of exon 9. Again, this variant was not present in 200 control samples. A pathogenic nature of this variant can be neither confirmed nor excluded. Neither *MSH2* nor *MLH1* mutations were identified in any of the 18 patients who were MSI-low. In the 18 patients who were MSI-high, one *MSH6* missense mutation, Tyr850Cys in exon 4, was detected. This mutation might be considered pathogenic, since it results in a substitution of amino acids belonging to different polarity groups and since it was not present in 200 control samples. In addition to this *MSH6* mutation, however, an *MLH1* frameshift mutation (649delC) was detected in the same patient. Pedigrees of the five families who had suspected HNPCC and *MSH6* mutations are shown in figure 1.

Discussion

To date (July 1999), 229 different germline mutations in five MMR genes (*MSH2*, *MLH1*, *PMS1*, *PMS2*, and *MSH6*) have been reported to the database of the International Collaborative Group on HNPCC (ICG-HNPCC). Among these mutations are two causative *MSH6* mutations. To verify our hypothesis that the MSI-low phenotype in patients with HNPCC or suspected HNPCC might be associated with germline *MSH6* mutations, we used two-dimensional DNA electrophoresis to scan *MSH6* for germline mutations both in patients with HNPCC who had MSI-low tumors and in patients with suspected HNPCC who had

Table 3

Germline Mutations of the *MSH6* Gene

PATIENT	EXON/INTRON	LOCATION	MUTATION ANALYSIS		
			Nucleotide Change	Predicted Protein Change	MSI STATUS
D840	Exon 2	Codon 144	AGC→ATC	Ser→Ile	Low
D716 ^a	Exon 4a	Codon 217	InsT (GAT→GATT)	Early stop codon	Low
HNPCC 49	Exon 4a	Codon 217	InsT (GAT→GATT)	Early stop codon	Low
D805	Exon 4a	Codon 217	InsT (GAT→GATT)	Early stop codon	Low
Div448	Exon 4h	Codon 850	TAC→TGC	Tyr→Cys	High
Div682	Exon 8	Codon 1258	CAA→TAA	Gln→Stop codon	Low
D854	Intron 10	+40 of exon 9	t→c +43 of exon 9 insertion 10 base (ctgaccttaa)	?	Low

^a Patient from family meeting the Amsterdam criteria.

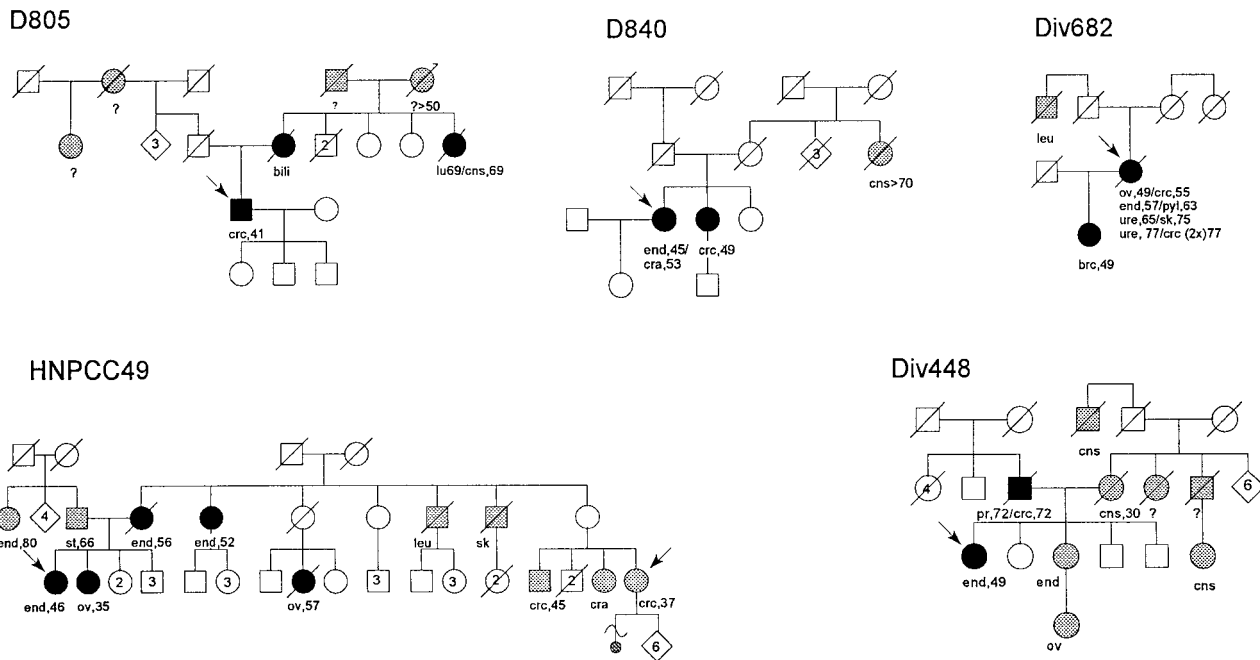

Figure 1 Pedigrees of the five families with suspected HNPCC and *MSH6* mutations. Of these five families, four (D805, D840, Div682, and HNPCC49) had MSI-low tumors. The index patient in family Div448 had a tumor displaying an MSI-high phenotype. Squares represent males; circles, females; diagonal stripes, patients who died; unblackened symbols, no tumor; blackened symbols, patients with histologically verified carcinomas; gray symbols, patients with tumors that were not histologically verified. Abbreviations indicate the site of cancer: bas = basocellular; bili = bile duct; brc = breast; cns = brain; cra = adenoma of the colon; crc = colon; end = endometrium; leu = leucemia; lu = lung; ov = ovary; pr = prostate; pyl = pyelum; sk = skin; st = stomach; ure = ureter; ? = tumor of unknown origin. The numbers after the abbreviations indicate the age at onset of cancer diagnosis.

either MSI-low or MSI-high tumors. Indeed, four presumably causative germline *MSH6* mutations were detected in the MSI-low group of patients who fulfilled one or more of our criteria (table 3) (see the Patients and Methods section, above). They account for 22% of our patients who have suspected HNPCC and MSI-low tumors. An additional germline *MSH6* mutation was detected in one of the three index patients from families who met the Amsterdam criteria and had MSI-low tumors (table 3), and one *MSH6* missense mutation was found in a patient with an MSI-high endometrial tumor. This patient, however, also had an *MLH1* mutation, which may explain the MSI-high phenotype. Our results suggest that *MSH6* may be involved in a substantial proportion of patients with HNPCC or suspected HNPCC and MSI-low tumors.

It has been suggested that tumors from patients with an *MSH6* germline mutation would preferably have instability of A-track markers (Papadopoulos et al. 1995; Akiyama et al. 1997; Miyaki et al. 1997). We found that in three of the six index patients with germline *MSH6* mutations, tumors exhibited instability at one or two A-track markers (BAT40 and BAT17). Our results, however, do not confirm the A-track instability hypothesis.

Furthermore, no significant correlation could be detected between instability of specific MSI markers and the presence of an *MSH6* mutation (table 2).

We also did not find a difference in instability of the different types of markers (mono-, di-, tri-, or tetranucleotide repeat markers) in different tumor types (table 2). Of course, one should keep in mind that these tumors are all MSI-low or MSS.

The two other *MSH6* germline mutations reported to date (Akiyama et al. 1997; Miyaki et al. 1997) were detected in families with MSI-high tumors. That most attention has been paid to families who have HNPCC tumors displaying an MSI-high phenotype might be an explanation for the low frequency of reported *MSH6* mutations. Another explanation might be compound heterozygosity with an *MLH1* or *MSH2* mutation, as was found in one of our patients. A third explanation might be an altered tumor phenotype. As in most tumors, some instability is observed, and it very well might be that, with progression of the tumor, the genomic instability increases and, consequently, tumors might change from an MSI-low to an MSI-high phenotype.

Recently, the ICG-HNPCC has modified the Amsterdam criteria by substituting HNPCC-associated cancers

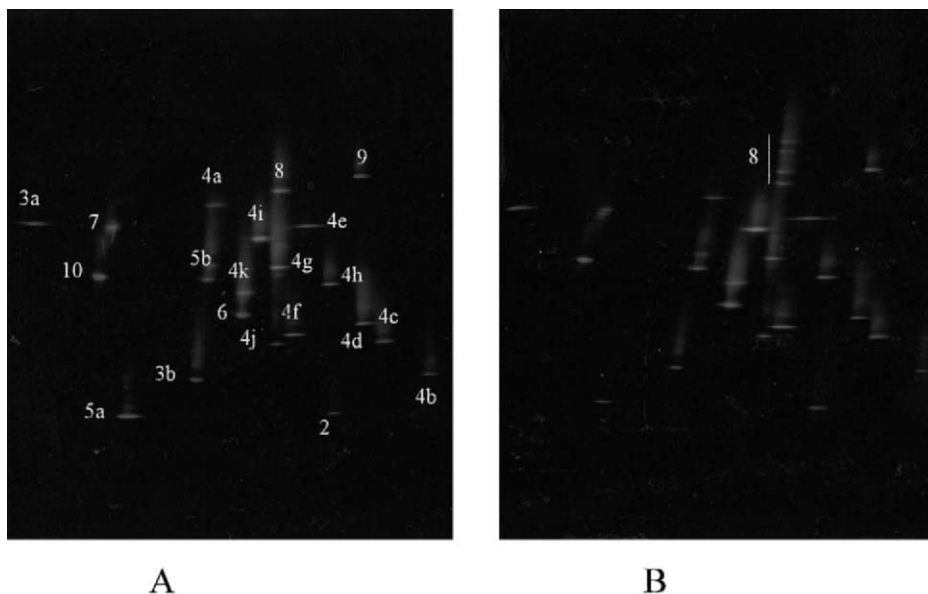

Figure 2 Two-dimensional DNA separation patterns of the 21 PCR-amplified fragments representing all exons of the *MSH6* gene, with the exception of exon 1. Exon 4 is amplified in 11 fragments; exons 3 and 5 are each amplified in two fragments. *A*, Two-dimensional separation pattern of a control individual. *B*, Two-dimensional separation pattern from patient Div682 (see table 1). Comparison of *A* and *B* clearly shows a heterozygous mutation in exon 8 of patient Div682. This mutation results in four spots (two homoduplexes and two heteroduplexes).

(colorectal cancer or cancer of the endometrium, small bowel, ureter, or renal pelvis) for colorectal cancer. The revised ICG-HNPCC criteria are called “Amsterdam criteria II” (Vasen et al. 1999). Six of our 36 families with suspected HNPCC fulfilled these revised criteria. Patients from two of these families had *MSH6* mutations (fig. 1). We also looked for correlations between the pattern of HNPCC-associated tumors in the families and the presence (fig. 1) or absence of an *MSH6* mutation. Although we did not find any correlation, we noticed that the three index patients from the families who had suspected HNPCC and an *MSH6* mutation had been given a diagnosis at <50 years of age and that endometrial tumors were observed in two of the three families. These observations may be the result of the selection criteria used. Also, brain tumors appeared to occur in two of the three families (fig. 1).

Our results may have important consequences for the genetic testing and management of families who have HNPCC and suspected HNPCC and MSI-low tumors. Additional confirmatory studies, however, are required to establish the full significance of our findings.

Acknowledgments

We thank Mr. Edwin Verlind, for sequencing the PCR products. This work is supported by grant RUG 97-1544 from the Dutch Cancer Society and by the Nijbakker-Morra Stichting, Laren.

Electronic-Database Information

Accession numbers and URLs for data in this article are as follows:

- GenBank, <http://www.ncbi.nlm.nih.gov/Genbank/GenBankOverview.html> (for the human cDNA of hMSH6 [accession number U28946] and the nucleotide sequences of all intron-exon boundaries [accession numbers U73732–U73737])
 ICG-HNPCC Database, <http://www.nfdht.nl/database/mdbchoice.htm> (for data on 229 different germline mutations in five MMR genes (*MSH2*, *MLH1*, *PMS1*, *PMS2*, and *MSH6*))
 Online Mendelian Inheritance in Man (OMIM), <http://www.ncbi.nlm.nih.gov/Omim> (for HNPCC [MIM 120435 and MIM 120436])

References

- Aaltonen LA, Peltomäki P, Leach FS, Sistonen P, Pylkkänen L, Mecklin J-P, Järvinen H, et al (1993) Clues to the pathogenesis of familial colorectal cancer. *Science* 260:812–816
 Aaltonen LA, Salovaara R, Kristo P, Canzian F, Hemminki A, Peltomäki P, Chadwick RB, et al (1998) Incidence of hereditary nonpolyposis colorectal cancer and the feasibility of molecular screening for the disease. *N Engl J Med* 338:1481–1487
 Akiyama Y, Sato H, Yamada T, Nagasaki H, Tsuchiya A, Abe R, Yuasa Y (1997) Germ-line mutation of the *bMSH6/GTBP*

- gene in an atypical hereditary nonpolyposis colorectal cancer kindred. *Cancer Res* 57:3920-3923
- Boland CR, Thibodeau SN, Hamilton SR, Sidransky D, Eshleman JR, Burt RW, Meltzer SJ, et al (1998) A National Cancer Institute Workshop on Microsatellite Instability for cancer detection and familial predisposition: development of international criteria for the determination of microsatellite instability in colorectal cancer. *Cancer Res* 58:5248-5257
- Chen J, Heerdt BG, Augenlicht LH (1995) Presence and instability of repetitive elements in sequences, the altered expression of which characterizes risk for colonic cancer. *Cancer Res* 55:174-180
- Corradi A, Croci L, Stayton CL, Gulisano M, Boncinelli E, Consalez GG (1996) cDNA sequence, map, and expression of the murine homolog of GTBP, a DNA mismatch repair gene. *Genomics* 36:288-295
- Dietmaier W, Wallinger S, Bocker T, Kullmann F, Fishel R, Rüschoff J (1997) Diagnostic microsatellite instability: definition and correlation with mismatch repair protein expression. *Cancer Res* 57:4749-4756
- Drummond JT, Li GM, Longley MJ, Modrich P (1995) Isolation of an hMSH2-p160 heterodimer that restores DNA mismatch repair to tumor cells. *Science* 268:1909-1912
- Edelmann W, Yang K, Umar A, Heyer J, Lau K, Fan KH, Liedtke W, et al (1997) Mutation in the mismatch repair gene *Msh6* causes cancer susceptibility. *Cell* 91:467-477
- Edwards A, Hammond HA, Jin L, Caskey CT, Chakraborty R (1992) Genetic variation at five trimeric and tetrameric tandem repeat loci in four human population groups. *Genomics* 12:241-253
- Goelz SE, Hamilton SR, Vogelstein B (1985) Purification of DNA from formaldehyde fixed and paraffin embedded human tissue. *Biochem Biophys Res Commun* 130:118-126
- Liu B, Parsons R, Papadopoulos N, Nicolaidis NC, Lynch HT, Watson P, Jass JR, et al (1996) Analysis of mismatch repair genes in hereditary non-polyposis colorectal cancer patients. *Nat Med* 2:169-174
- Lu S-L, Kawabata M, Imamura T, Akiyama Y, Nomizu T, Miyazono K, Yuasa Y (1998) HNPCC associated with germline mutation in the TGF- β type II receptor gene. *Nat Genet* 19:17-18
- Markowitz S, Wang J, Myeroff L, Parsons R, Sun L, Lutterbaugh J, Fan RS, et al (1995) Inactivation of the type II TGF- β receptor in colon cancer cells with microsatellite instability. *Science* 268:1336-1338
- Miyaki M, Konishi M, Tanaka K, Kikuchi-Yanoshita R, Muraoka M, Yasuno M, Igari T, et al (1997) Germline mutation of *MSH6* as the cause of hereditary nonpolyposis colorectal cancer. *Nat Genet* 17:271-272
- Nyström-Lahti M, Wu Y, Moisio AL, Hofstra RMW, Osinga J, Mecklin JP, Järvinen HJ, et al (1996) DNA mismatch repair gene mutations in 55 kindreds with verified or putative hereditary non-polyposis colorectal cancer. *Hum Mol Genet* 5:763-769
- Palombo F, Gallinari P, Iaccarino I, Lettieri T, Hughes M, D'Arrigo A, Truong O, et al (1995) GTBP, a 160-kilodalton protein essential for mismatch-binding activity in human cells. *Science* 268:1912-1914
- Papadopoulos N, Nicolaidis NC, Liu B, Parsons R, Lengauer C, Palombo F, D'Arrigo A, et al (1995) Mutations of GTBP in genetically unstable cells. *Science* 268:1915-1917
- Parsons R, Myeroff LL, Liu B, Willson JKV, Markowitz SD, Kinzler KW, Vogelstein B (1995) Microsatellite instability and mutations of the transforming growth factor β type II receptor gene in colorectal cancer. *Cancer Res* 55:5548-5550
- Peltomäki P, de la Chapelle A (1997) Mutations predisposing to hereditary nonpolyposis colorectal cancer. *Adv Cancer Res* 71:93-119
- Peltomäki P, Lothe RA, Aaltonen LA, Pylkkänen L, Nyström-Lahti M, Seruca R, David L, et al (1993) Microsatellite instability is associated with tumors that characterize the hereditary non-polyposis colorectal carcinoma syndrome. *Cancer Res* 53:5853-5855
- Vasen HFA, Mecklin J-P, Khan PM, Lynch HT (1991) The International Collaborative Group on Hereditary Non-Polyposis Colorectal Cancer (ICG-HNPCC). *Dis Colon Rectum* 34:424-425
- Vasen HFA, Watson P, Mecklin J-P, Lynch HT, ICG-HNPCC (1999) New clinical criteria for hereditary nonpolyposis colorectal cancer (HNPCC, Lynch syndrome) proposed by the International Collaborative Group on HNPCC. *Gastroenterology* 116:1453-1456
- Wu Y, Hofstra RMW, Scheffer H, Uitterlinden AG, Mullaart E, Buys CHCM, Vijg J (1996) Comprehensive and accurate mutation scanning of the CFTR gene by two-dimensional DNA electrophoresis. *Hum Mutat* 8:160-167
- Wu Y, Nyström-Lahti M, Osinga J, Looman MWG, Peltomäki P, Aaltonen LA, de la Chapelle A, et al (1997) MSH2 and MLH1 mutations in sporadic replication error-positive colorectal carcinoma as assessed by two-dimensional DNA electrophoresis. *Genes Chromosomes Cancer* 18:269-278
- Wu Y, Stulp RP, Elfferich P, Osinga J, Buys CHCM, Hofstra RMW (1999) Improved mutation detection in GC-rich DNA fragments by combined DGGE and CDGE. *Nucleic Acids Res* 27:e9