

Available online at [www.sciencedirect.com](http://www.sciencedirect.com)**SciVerse ScienceDirect**

Physics Procedia 43 (2013) 10 – 20

Physics

**Procedia**The 7<sup>th</sup> International Topical Meeting on Neutron Radiography

## A review of significant advances in neutron imaging from conception to the present

J. S. Brenizer\*

*Pennsylvania State University, Department of Mechanical and Nuclear Engineering, 229 Reber Building, University Park, Pennsylvania, 16802, USA*

### Abstract

This review summarizes the history of neutron imaging with a focus on the significant events and technical advancements in neutron imaging methods, from the first radiograph to more recent imaging methods. A timeline is presented to illustrate the key accomplishments that advanced the neutron imaging technique. Only three years after the discovery of the neutron by English physicist James Chadwick in 1932, neutron imaging began with the work of Hartmut Kallmann and Ernst Kuhn in Berlin, Germany, from 1935-1944. Kallmann and Kuhn were awarded a joint US Patent issued in January 1940. Little progress was made until the mid-1950's when Thewlis utilized a neutron beam from the BEPO reactor at Harwell, marking the beginning of the application of neutron imaging to practical applications. As the film method was improved, imaging moved from a qualitative to a quantitative technique, with applications in industry and in nuclear fuels. Standards were developed to aid in the quantification of the neutron images and the facility's capabilities. The introduction of dynamic neutron imaging (initially called real-time neutron radiography and neutron television) in the late 1970's opened the door to new opportunities and new challenges. As the electronic imaging matured, the introduction of the CCD imaging devices and solid-state light intensifiers helped address some of these challenges. Development of improved imaging devices for the medical community has had a major impact on neutron imaging. Additionally, amorphous silicon sensors provided improvements in temporal resolution, while providing a reasonably large imaging area. The development of new neutron imaging sensors and the development of new neutron imaging techniques in the past decade has advanced the technique's ability to provide insight and understanding of problems that other non-destructive techniques could not provide. This rapid increase in capability and application would not have been possible without the advances in computer processing speed and increased memory storage. For example, images with enhanced contrast are created by using the reflection, refraction, diffraction and ultra small angle scattering interactions. It is somewhat ironic that, like the first development of neutron images, the technique remains limited by the availability of high-intensity neutron sources, both in the facility cost and portability.

© 2013 The Authors. Published by Elsevier B.V. Open access under [CC BY-NC-ND license](http://creativecommons.org/licenses/by-nc-nd/4.0/).  
Selection and/or peer-review under responsibility of ITMNR-7

\* Corresponding author. Tel.: 814-863-6384  
E-mail address: [jsbnuc@enr.psu.edu](mailto:jsbnuc@enr.psu.edu).

Keywords: Neutron Imaging; Radiography; Radioscopy; Tomography; Non-destructive testing

---

## 1. Introduction

Neutron imaging began with the work of Hartmut Kallmann and Ernst Kuhn [1] only three years after the discovery of the neutron by English physicist James Chadwick in 1932 [2]. Their work was stopped near the end of Second World War in Europe and little progress was made from their discovery until the mid-1950's when Thewlis utilized a neutron beam from the BEPO reactor at Harwell for neutron imaging [3]. The availability of a higher flux of neutrons from the reactor source opened the way for the utilization of neutron radiography as a non-destructive testing (NDT) technique that could provide insight into a number of otherwise challenging practical applications. Many of these involved penetrating high atomic number materials, such as metals, to observe internal low atomic number materials. Development of neutron imaging facilities and devices continued from the late 1950's to the present. The pace of development of new sensors has varied over time, often driven by the characteristics required for new applications. Improved imaging sensors and new neutron imaging techniques, especially in the past decade, has advanced the method's ability to provide insight and understanding of problems that other NDT methods could not provide. The increase in neutron imaging applications and enhanced capabilities would not have been possible without the advances in computers, digital memory chips and data storage devices.

This review summarizes the history of neutron imaging with a focus on the significant events and technical advancements in neutron imaging methods, from the first radiograph to more recent imaging methods. The review follows a chronological order of the initiating event or advancement with additional discussion of its importance and impact.

## 2. The Early Years of Neutron Imaging

In 1935 Hartmut Kallmann and Ernst Kuhn began to make radiographic images of objects using neutrons from Ra-Be sources and a small (d.n) neutron generator. Carl-Otto Fischer provided an excellent review of the neutron imaging work conducted in Berlin, Germany, in the period from 1935-1944.[4] Kallmann and Kuhn were awarded a joint US Patent in January 1940.[5] This patent, entitled "Photographic Detection of Slowly Moving Neutrons", detailed the basic radiographic converter-film system and the vacuum cassette, as shown in Figs. 1 and 2 of the original patent, presented here in Fig. 1. Kallmann and Kuhn's original design for a vacuum cassette is very close to those that are still being used in neutron radiography. With the higher intensity of the neutron accelerator, Peter was able to produce radiographs of different objects. The work ended just before the Russian army reached Berlin in December of 1944. Peter and Kallmann did not publish their work until 1946 and 1948, respectively.[6,1] It is interesting to note that the Fuji Photo Film Co. and the Japan Atomic Energy Research Institute referenced Kallmann and Kuhn's patent in their 1998 US Patent 5852301 entitled "Method for forming neutron images" [7] that describes their stimulable phosphor neutron imaging sheets.

Little progress was made until the mid-1950's when Thewlis utilized a neutron beam with a flux of between  $10^8$  to  $10^9$  n/cm<sup>2</sup>-s from the BEPO reactor at Harwell [3], marking the beginning of the utilization of neutron imaging in practical applications. As the film method improved and became a recognized NDT method, neutron imaging began to change from providing just qualitative insight about

Jan. 9, 1940.

H. KALLMANN ET AL

2,186,757

PHOTOGRAPHIC DETECTION OF SLOWLY MOVING NEUTRONS

Filed March 24, 1938

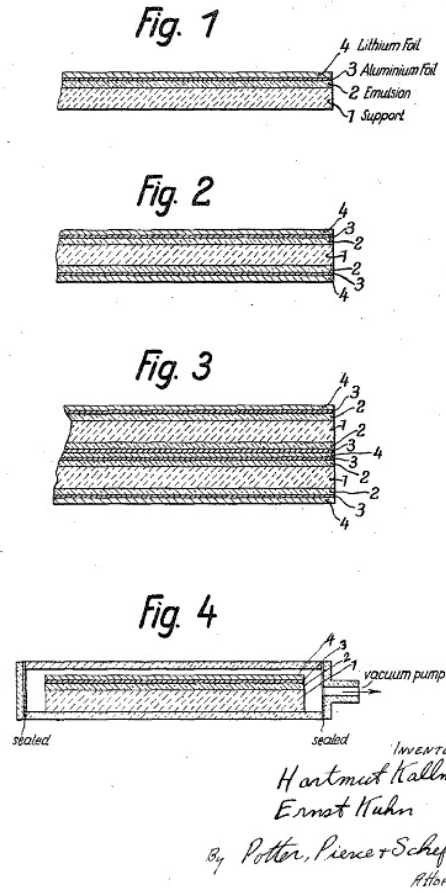

Fig 1. Figures 1 through 4 from the Kallmann and Kuhn United States Patent 2,186,757, January 9, 1940, illustrating possible converter and film configurations and a vacuum cassette for neutron imaging.[5]

an object to a technique that could also provide quantitative information about the details within the object. This opened opportunities to applications in industry and in nuclear fuels.

Even so, by 1964 there were only two neutron radiography programs in the United States of America (USA) and two in Europe.[8] One of the first neutron radiography programs in the USA was at the Argonne National Laboratory that was started under the direction of McGonnagle (and subsequently taken up by Berger). The significance of this work is that McGonnagle, first using a diffracted beam from the CP-5 reactor, and subsequently using a beam from the 200 kW Juggernaut reactor, produced what Berger referred to as “one of the earliest reactor quality neutron radiographs.” [8] Additionally, at the latter facility, the first application neutron radiographs of radioactive fuel were taken in 1963.[9]

In Europe during the same period, interest in neutron radiography was increasing. In his 1965 book on the basics of neutron radiography [10], Berger stated that the parallel collimator was preferred to obtain an adequate neutron flux. However, Barton, working at the 4 MW pool reactor Melusine at Grenoble, France, was developing a divergent collimator that would allow large neutron radiographs to be made. [11] In a subsequent article, Barton suggested that the divergent collimator was advantageous for neutron radiography.[12]

While much of the neutron radiography focused on using attenuation of thermal neutrons, investigation of using neutrons at other energies was beginning. Tochilin [13] describes experimental work on fast neutron radiography at the University of California 60-inch cyclotron, using two different neutron energies. Barton [14,15] was also investigating the use of different energy neutrons; an epithermal beam emerging radially from the core of the 5 MW Herald reactor at the Atomic Weapons Research Establishment, Aldermaston, England, and cold neutrons to examine steel at the same facility.

A number of journal articles and several books were published to describe the neutron imaging methodologies. Two excellent examples are Berger [11] and Hawkesworth and Walker [16]. From the mid-1960's through the 1970's, a number of nuclear technology research centers became involved in neutron imaging. Interestingly, much of the work involved the examination of new and used nuclear fuel. The techniques used to examine the highly radioactive fuel were the indirect method and the track etch method.[8,17] While the use of these methods essentially disappeared over the last two decades, there may well be a resurgence if new nuclear fuel types are produced.

Starting about 1968, a number of facilities began to offer neutron radiography commercial services, a practice that continues today. The first two reactors to offer such services were the Nuclear Test Reactor at the General-Electric Vallecitos Center and the TRIGA type reactor at the Aerotest Company.[9] A number of reactors at European national laboratories, including the Fontenay-Aux-Roses in France and the Harwell Nondestructive Testing Center in England, also began providing neutron radiography as a service.[9]

### **3. A Maturing NDT Method**

As neutron imaging moved into the 1970's, the need to shift from a qualitative or subjective examination method to a quantifiable and standardized method was becoming obvious. For neutron imaging to become an accepted NDT method, like x-ray radiography or ultrasonic testing, purchasers of the newly offered radiographic services wanted to have quality control monitors and quantifiable measures in place to be able to verify the reliability of the method to detect defects and object characteristics for mission critical parts, especially in the aerospace industry. This was especially true for the Apollo program, where stringent standard methods and recommend practices were already in place for other NDT methods.[18] Additionally, many practitioners of neutron imaging recognized the relationship between standards and the acceptance of a new NDT method.[19] Although there was not unanimous agreement as to the design of the standards, efforts to establish communication among the international community of neutron radiographers resulted in the formation of the Association of Neutron

Radiographers (ANR) in 1969 under the leadership of Dr. J. P. Barton.[18] Dr. W. L. Whittemore lead an effort to develop a personnel qualification standard under the authority of the American Society for Nondestructive Testing (ASNT), SNT-TC-1A) that was first published in 1974.[ 20]

Concurrently, work began in the then American Society for Testing and Materials (ASTM) to develop image quality indicators, terminology, and recommended practices. ASTM Committee E-7 on Nondestructive Testing established a Section E07.01.02 on Neutron Radiography under the chairmanship of E. L. Criscuolo.[18] Out of this Section came two indicators that became internationally recognized: the Beam Purity Indicator (BPI) and the Sensitivity Indicator (SI). Originally, the sensitivity indicator consisted of four different devices, referred to as Type A, B, C and D.[18] The devices received ASTM approval in 1975 and are still in use today, although the SI device was refined and made into a single device. Efforts were made to establish neutron imaging standards in the International Organization for Standardization (ISO) under committee ISO/TC/ 135/SC 5/WG 4 in the 1990's, but the effort did not result in any ISO standards.[21] Development and maintenance of neutron imaging standards continues today in ASTM International's Subcommittee E07.05 Neutron Radiology.

In 1973, the first conference relating specifically to neutron imaging, "Radiography With Neutrons," was held at the University of Birmingham. The proceedings of this conference were published in 1975.[22] This conference played an important role in bringing the neutron imaging researchers and practitioners together as a community. Neutron imaging was growing rapidly internationally, with facilities in the United States, in many Europe countries and in Japan.

Dynamic imaging was being performed by those working in x-ray radiography and interest quickly spread to the neutron radiography community. In 1966, H. Berger reported the results of his tests of what was then referred to as a neutron television system. [23] The system consisted of a neutron sensitive image intensifier tube coupled to a vidicon television camera with 525 lines and a 30 frame per second frame rate. The system was capable of 0.5 mm resolution. At the Central Research Laboratory, Tokyo Shibaura (Toshiba) Electric Co., Ltd., Kawasaki, Japan, S. Kawasaki [24] was working with a collimated thermal beam of  $10^4$  n/cm<sup>2</sup>-s from a high yield (d,t) neutron generator. The system, shown in Fig. 2, was utilized a multi-stage image intensifier. Spatial resolution was approximately 1 mm with a neutron flux of  $5 \times 10^3$  n/cm<sup>2</sup>-s. In the United Kingdom, Hendry and his colleagues utilized the Materials Testing Reactor neutron radiography unit at Dounreay with an image intensifier to provide "immediate radiography" by direct viewing of a scintillating plate.[25] By the mid-1970's real-time neutron imaging systems were commercially available, most based on an electrostatic image intensifier, a gadolinium oxysulfide scintillator (GOS) and a isocon or newvicon television tube. Many of these systems were initially developed for x-ray imaging, and either had a GOS already incorporated into the design or change the scintillator to a GOS screen. Thomson-CSF produced a robust neutron intensifier tube that was widely used through the 1990's for dynamic neutron imaging. [26] High speed neutron radiography was accomplished by Bossi, Robinson and Barton [27] at the Oregon State University's TRIGA reactor by utilizing a reactor pulse and a high speed camera. The high-speed motion neutron radiography incorporated a pulsing reactor, a low L/D ratio collimator (30 in the horizontal and 41 in the vertical directions, a scintillator screen, an image intensifier, and a high speed film video camera. The camera was synchronized to the reactor pulse. An exposure time of 40  $\mu$ s per frame was obtained at a frame rate of 10000 frames per second.

In the mid-1970's, interest began to build to perform computed axial tomography with neutrons. Early efforts demonstrated the technique's possibilities, but were hindered by beam intensities, the lack of high-resolution digital sensors, and slow computers with limited memory space. Most facilities were using a well collimated beam, a rotating sample holder, and x-ray film as the sensor. [28,29] Although the preliminary results were very poor in comparison to today's neutron computed tomography (NCT)

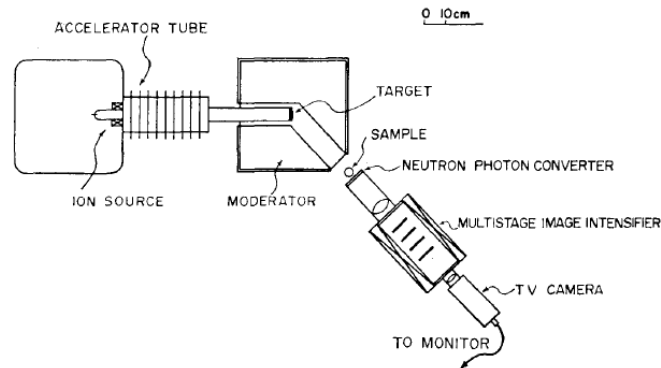

Fig. 2. A schematic diagram of the (d,d) neutron generator based thermal neutron imaging system used by Kawasaki in 1968 for neutron computed tomography.[24]

reconstructions, many of the limitations associated with the initial attempts would soon be overcome by using the then new real-time neutron imaging systems combined with the availability of rapidly growing computational capabilities. The number of researchers working in NCT grew appreciably. For example, in the proceedings of the first World Conference on Neutron Radiography (WCNR) in 1981, there was one paper on NCT while at the second WCNR held in 1986, there were ten papers on NCT. [30,31] The NCT technique opened a new field in neutron imaging that is still expanding today.

#### 4. A Revitalized NDT Method

As neutron imaging moved into the 1980's more researchers were joining the neutron imaging community, bringing new ideas for both detectors and applications. An event that was to have a significant and long-term impact on neutron imaging was the establishment of the Neutron Radiography World Conference (WCNR) series and the publication of the conference proceedings.[30] With the exception of the 1973 University of Birmingham "Radiography with Neutrons" conference and several ASTM symposia, those who were actively involved in neutron imaging and those interested in learning the capabilities and limitations of the technique had little opportunity to gather to exchange ideas and discuss new techniques and applications. Papers were usually published in the meeting proceedings, the journal associated with the application, or in an NDT journal not easily accessible outside the NDT community. In a time without web-based searches of data bases and easily retrieved electronic articles, the majority of the journal articles, monographs, conference proceedings and books on neutron imaging were not readily available to those not intimately involved in neutron imaging. For example, the first WCNR was held in San Diego, California, USA in 1981 with 124 participants. The meeting's proceedings of the meeting were published in 1983.[30] These proceedings quickly became a go-to reference for neutron radiography, but the distribution was limited and the papers were not accessible outside of the hardcopy proceedings. The second WCNR was held in Paris, France in 1986 with 163 participants and the third WCNR was held in Osaka, Japan in 1989 with 182 participants.[31] While the WCNR proceedings were a valuable source for neutron imaging papers, MacGillivray and Brenizer decided that a second smaller meeting should be established that promoted discussion among the active practitioners of neutron imaging and resulted in journal papers on neutron imaging that would be readily accessible through indexing databases. The first International Topical Meeting on Neutron Radiograph

focused on System Design and Characterization was held in Pembroke, Ontario, Canada in 1990.[32] The meeting, while successful, did not meet its goal of publishing its proceedings in an indexed journal. The second ITMNR, held in 1995 in Shonan Village Center, Japan, maintained the same theme, with the proceedings published in Nuclear Instrumentation and Methods in Physics.[33] There have been nine WCNR and seven ITMNR meetings to date (including the June 2012 meeting). While initially two independent series, the meetings are now coordinated under the International Society of Neutron Radiology (ISNR) and each meeting is held on a four year cycle with two years between each meeting. Smaller focused topical meetings and workshops, such as the NEUtron WAVElength Dependent Imaging (NEUWAVE) Workshop series, have also begun.

Regardless of the advancements in neutron imaging, the number of practitioners and neutron imaging facilities began to decline from the mid-1980's through the 1990's. There were two major factors that negatively impacted neutron imaging research and service work: 1) new competitive NDT techniques were developed that were portable, less expensive (both in capital costs and the cost of the services), required a shorter examination time and did not activate the examined materials, and 2) an international climate that did not fund or support nuclear activities, such as university and national laboratory research reactors and nuclear research. Activity and participation fell in all neutron imaging areas, ranging from facility and detector development to imaging standards development.

Beginning in the mid 1990's there has been renewed interest in neutron imaging sparked by new facilities, new imaging devices, and older techniques now made possible by advances in computer processors, memory storage and imaging sensors. Five new neutron imaging facilities became operational between 1994 and 2004. The Radiography Station at the MYA KFKI Atomic Energy Research Institute in Budapest, Hungary began operation in 1994 at the refurbished 10 MW reactor.[34] The facility was designed to provide simultaneous dynamic gamma and neutron radiography. The Neutron Transmission Radiography (NEUTRA) station at the Paul Scherrer Institut spallation neutron source SINQ became operational in 1997.[35] This facility has a high collimation ratio, low gamma background and large beam diameter, making it Europe's most powerful radiography stations. Recently, the a cold neutron imaging station was added to the ICON beam line that complements the NEUTRA facility.[36] In the United States, the Neutron Imaging Facility (NIF) located at the National Institute for Standards and Technology (NIST) Center for Neutron Research in Gaithersburg, Maryland, began operation in 2003.[37]. The design objective of facility was to provide a large beam diameter and a high fluence rate in order to produce images of dynamic systems. Also in 2003, the neutron radiography and fully digital tomography facilities became operational at the Atomic Energy Corporation of South Africa (AEC) 20 MW Materials Testing Reactor (SAFARI-1) near Pretoria, South Africa.[38] This is the only such facility in the southern hemisphere. The first images at the ANTARES neutron imaging facility on beam line SR4B in the northeast corner of the experimental hall at FRM II reactor were taken in the spring of 2004.[39] The FRM II is located on the research and university campus of the Technische Universität München near Garching, Germany. It went critical on March 2, 2004, and reached the full power of 20 MW on August, 2004. The ANTARES is used for a wide variety of neutron imaging methods, including transmission radiography and neutron tomography.

There have been three technology achievements that have had a dramatic change in neuron imaging in the last two decades, none of which were initially designed to enhance neutron imaging. They are:

- The dramatic improvement in computer processor and bus speeds, coupled with the availability of large, fast active memory and data storage devices. This has enabled data analysis, image processing and image reconstructive techniques that were either not possible (or at least impractical) only ten years ago. Additionally, the costs for the fast and powerful computers

required for data collection and processing, once a major facility expense, are now quite low compared to the cost of the imaging facility hardware.

- The on-going development of CCD imaging chips and low-light cameras with multiple millions of pixels. These CCD cameras have increased the achievable spatial resolution in neutron images, especially large format images. Not only has pixel size been reduced, but the transfer rate of image data has increased, the sensitivity to low-light level is quite high, the solid-state cooling has reduced black current noise, and the cost has dropped steadily over the last decade. With a light-tight enclosure, a scintillator screen, one or two front surfaced mirrors, a good lens and a low-light CCD camera, one can set up a very acceptable neutron imaging system quickly and inexpensively.
- The development of improved imaging devices for the medical community has had a major impact on neutron imaging. Photostimulable phosphor plates provide an alternative for x-ray film, and as the spatial resolution of the plates and plate readers improve, film is being rapidly displaced in both x-ray and neutron radiography. Manufactures of the systems incorporating photostimulable phosphors have called this technique Computed Radiography (or less frequently Computed Radiology). The advantages of the CR systems are clear - they have a linear response over a wide exposure range, the plates are reusable, no processing chemicals are required, no hazardous wastes are produced and they can produce a large-format digital image.[40] This makes the use of CR systems very attractive for both medical and NDT applications. However, CR systems are having a dramatic effect on the neutron radiography service providers and the customers that rely on neutron radiography for quality assurance of their parts and products. Film manufactures are producing fewer film types, and many of those used in specialized applications, such as the single emulsion high resolution films used in direct neutron radiography, have been or will soon be discontinued. In addition, there are currently no standards or image quality devices available for use with photostimulable phosphor plates.

Other developments, such as the amorphous silicon sensors which offer improved temporal resolution while providing a reasonably large imaging area for dynamic imaging, have impacted certain applications of neutron imaging, but have not yet had the wide-ranging impact of the three mentioned above.

The new methods referred to as phase contrast imaging take full advantage of the advances in facility, computational and detector advances. Images with enhanced contrast are created by using the reflection, refraction, diffraction and ultra small angle scattering interactions, rather than simple neutron attenuation. Wolfgang Treimer published the first paper [41] to demonstrate that the scattered neutron signal of weakly absorbing materials can be used to determine their location and size within a large matrix. The small angle scattering contrast imaging in NCT was also demonstrated in the reconstruction of a bundle of 14- $\mu\text{m}$  glass fibers. [42] A later paper in *Nature* by Allman, et al., also demonstrated the contrast in low attenuating materials when using what they referred to as phase radiography with neutrons. [43] In 1997 Treimer, Ernst and Herzig reconstructed the magnetic field using polarized neutron imaging. Initially considered a very specialized area of neutron imaging, the technique began to generate wider interest following the publication of two papers in 2005 and 2008.[44,45]

## 5. Summary and Conclusions

As neutron imaging approaches its eightieth year as a NDT method, it is important to keep in mind the seminal events and technical advancements that brought neutron imaging to its present state. Many accomplishments, discoveries and inventions have contributed to each of those listed as important or significant. Fig. 3 gives a timeline presentation of the events and advancements that have been made in neutron imaging. It is clear from the timeline that there was little activity over the first twenty years after



the initial neutron images were created. Many significant events and advances were made from 1965 to the present, and most recently, a number of new facilities and new neutron imaging techniques have been developed.

As is always the case many accomplishments, discoveries and inventions have contributed to or refined each of the items identified in this review as important or significant. It remains to be seen which of the advances, discoveries, or newly developed techniques that were reported in WCNR-9 and in the ITMNR-7 meetings will have a significant impact on neutron imaging. Nevertheless, the impact of the events and advances identified in this review continue to have a significant impact on the neutron imaging methods and on their application to solve challenges and provide insight into research problems and practical applications.

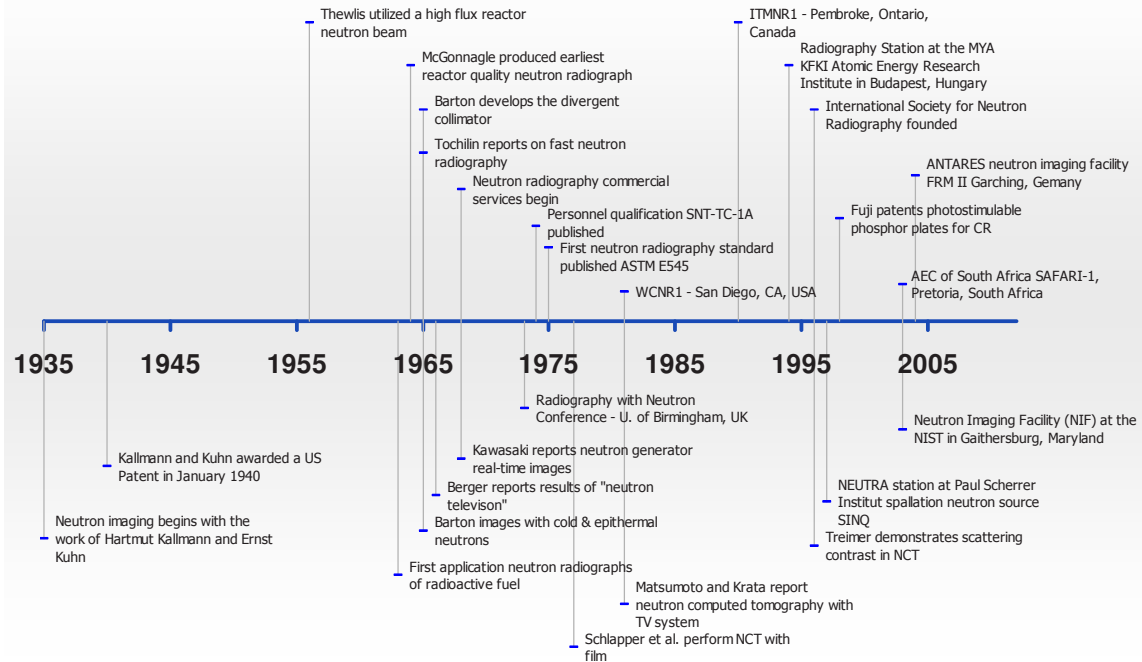

Fig. 3. A timeline showing the significant events and technology advances in neutron imaging.

## References

- [1] Kallmann H. Neutron Radiography. *Research* 1948;**1**:254-260.
- [2] Chadwick J. Possible Existence of a Neutron. *Nature* 1932; **129**:312.
- [3] Thewlis J. Neutron Radiography. *British Journal of Applied Physics* 1956;**7**: 345-350.
- [4] Fischer C. The History of the First Neutron Radiographs in Berlin 1935-1944. In: Barton JP, editor. *Neutron Radiography (4), Proceedings of the Fourth World Conference*, San Francisco, CA: Gordon and Breach Science Pub; 1994, p. 3-9.
- [5] Kallmann H, Kuhn E. Photographic Detection of Slowly Moving Neutrons. United States Patent 2,186,757, January 9, 1940.
- [6] Peter O. Neutronen-Durchleuchtung. *Zeitschrift Naturforschung Teil A* 1946;**1**:557-559.
- [7] Niimura N, Karasawa Y, Takahashi K, Saito H. Method for Forming Neutron Images. United States Patent 5,852,301, December 22, 1998.

- [8] Barton JP. Neutron Radiography – An Overview. In: Berger H, editor. *Practical Applications of Neutron Radiography and Gaging*: ASTM STP 586, American Society for Testing and Materials; 1976, p.5-19.
- [9] Berger H, Beck WN. Neutron Radiographic Inspection of Radioactive Irradiated Reactor Fuel Specimens. *Nuclear Science and Engineering* 1963;**15**:411-414.
- [10] Berger H. *Neutron Radiography: Methods, Capabilities, and Applications*. Amsterdam - New York: Elsevier Pub. Co.; 1965.
- [11] Barton JP, Perves JP. Underwater Neutron Radiography with Conical Collimator. *British Journal of Non-Destructive Testing* 1966;**8**:79-83.
- [12] Barton JP. Divergent Beam Collimator for Neutron Radiography. *Materials Evaluation* 1967;**25**:45A.
- [13] Tochilin E. Photographic Detection of Fast Neutrons: Application to Neutron Radiography. *Physics in Medicine and Biology* 1965;**10**:477-490.
- [14] Barton JP. Neutron Radiography Using a Crystal Monochromator. *Journal of Scientific Instruments* 1965;**42**:540.
- [15] Barton JP. Radiographic Examination Though Steel Using Cold Neutrons. *British Journal of Applied Physics* 1965;**16**:1833-1841.
- [16] Hawkesworth MR, Walker J. Review: Radiography with Neutrons. *Journal of Materials Science* 1969;**4**:817-835.
- [17] Alter HW. Track-Etch Neutron Radiography. United States Patent 3,457,408, July 22, 1969.
- [18] Haskins J. Standards for Neutron Radiography. In: Berger H, editor. *Nondestructive Testing Standards – A Review*: ASTM STP 624, American Society for Testing and Materials; 1977, p.108-114.
- [19] Barton JP. A Visual Image Quality Indicator (VISQI) for Neutron Radiography. *Journal of Materials* 1972;**7**:18-24.
- [20] Whittemore WL. Personnel Training and Certification. In: Berger H, editor. *Practical Applications of Neutron Radiography and Gaging*: ASTM STP 586, American Society for Testing and Materials; 1976, p.87-92.
- [21] Brenizer JS. Current and Future Neutron Radiologic NDT Standards. In: Berger H, Mordfin L, editors. *Nondestructive Testing Standards-Present and Future*: ASTM STP 1151, American Society for Testing and Materials; 1992, p.34-40.
- [22] Hawkesworth MR, editor. *Radiography With Neutrons: Conference Held 10-12 September, 1973 at the University of Birmingham*. London: British Nuclear Energy Society; 1975.
- [23] Berger H. Characteristics of a Thermal Neutron Television Imaging System. *Materials Evaluation* 1966;**24**:475-481.
- [24] Kawasaki S. A Thermal Neutron Television System Using a High Yield Neutron Generator. *Nuclear Instruments & Methods* 1968;**62**:311-315.
- [25] Hendry IC, Spowart AR, Robertson JA, Oliphant AJ. The Display of Neutron Radiography Results by Direct Viewing of a Scintillating Plate. *Journal of Physics. E, Scientific Instruments* 1969;**2**:191-192.
- [26] Verat M, Rougeot H, Driard B, Neutron Image Intensifier Tubes. In: Barton JP, Von Der Hardt P, editors. *Neutron Radiography, Proceedings of the First World Conference*, San Diego, CA: D. Reidel Pub. Co.; 1983, p. 601-607.
- [27] Bossi RH, Robinson AH, Barton JP. High Frame-rate Neutron Radiography of Dynamic Events. In: Barton JP, Von Der Hardt P, editors. *Neutron Radiography, Proceedings of the First World Conference*, San Diego, CA: D. Reidel Pub. Co.; 1983, p. 643-651.
- [28] Schlapper GA, Brugger RM, Seydel JE, Larsen GN. Neutron Tomography Investigations at the Missouri University Research Reactor. *Transactions of the American Nuclear Society* 1977;**26**:39.
- [29] Matsumoto G, Krata S, The Neutron Computed Tomography. In: Barton JP, Von Der Hardt P, editors. *Neutron Radiography, Proceedings of the First World Conference*, San Diego, CA: D. Reidel Pub. Co.; 1983, p. 899-906.
- [30] Barton JP, Von Der Hardt P, editors. *Neutron Radiography, Proceedings of the First World Conference*, San Diego, CA: D. Reidel Pub. Co.; 1983.
- [31] Barton JP, Farny G, Person J, Röttger H, editors. *Neutron Radiography, Proceedings of the Second World Conference*, Paris, France: D. Reidel Pub. Co.; 1987.
- [32] MacGillivray GM, Brenizer JS, editors. *Proceedings of the First International Topical meeting on Neutron Radiography System Design and Characterization*. Chalk River, Ontario, Canada: Canadian Nuclear Society; 1994.

- [33] Kobayashi H, Mochiki K, editors. *Neutron Radiography System Design and Characterization - Proceedings of the Second International Topical Meeting*. Shonan Village Center/Rikkyo University Japan: North Holland;1996.
- [34] Balasko M, Svab, E. Dynamic Neutron Radiography Instrumentation and Applications in Central Europe. *Nuclear Instruments & Methods in Physics Research, Section A (Accelerators, Spectrometers, Detectors and Associated Equipment)* 1996;**377**:140-143.
- [35] Lehmann EH, Vontobel P, Wiesel L. Properties of the Radiography Facility NEUTRA at SINQ and Its Potential for Use as a European Reference Facility. In: Fujine S, Kobayashi H, Kanda K, editors. *Neutron Radiography (6), Proceedings of the Sixth World Conference*, Osaka, Japan: Gordon and Breach Science Pub.; 2001, p. 151-158.
- [36] Kaestner AP, Hartmann S, Kühne G, Frei G, Grünzweig C, Josic L, Schmid F, Lehmann EH. The ICON Beamline - A Facility for Cold Neutron Imaging at SINQ. *Nuclear Instruments and Methods in Physics Research, Section A: Accelerators, Spectrometers, Detectors and Associated Equipment* 2011; **659**:387-393.
- [37] Hussey DS, Jacobson DL, Arif M, Huffman PR, Williams RE, Cook JC. New Neutron Imaging Facility at the NIST. *Nuclear Instruments & Methods in Physics Research, Section A (Accelerators, Spectrometers, Detectors and Associated Equipment)* 2005;**542**:9-15.
- [38] De Beer FC, Strydom WJ. Neutron Radiography at Safari-1 in South Africa. *Nondestructive Testing and Evaluation* 2001;**16**:163-176.
- [39] Calzada E, Schillinger B, Grunauer F. Construction and Assembly of the Neutron Radiography and Tomography Facility ANTARES at FRM II. *Nuclear Instruments & Methods in Physics Research, Section A (Accelerators, Spectrometers, Detectors and Associated Equipment)* 2005;**542**:38-44.
- [40] Kobayashi H. A History of Basic Neutron Radiography Research at Rikkyo University. *Nuclear Instruments & Methods in Physics Research, Section A (Accelerators, Spectrometers, Detectors and Associated Equipment)* 2011;**651**:6-11.
- [41] Treimer W. Neutron Tomography with Thermal and Monochromatic Neutrons. In: C. O. Fischer CO, Stade J., Bock W. editors. *Proceedings of the 5th World Conference on Neutron Radiography 17-20 June 1996*, Berlin, Germany: Deutsche Gesellschaft Für Zerstorungsfreie Prüfung Pub.; 1997, p. 69-77.
- [42] Treimer W, Feye-Treimer U, Herzig C. On Neutron Tomography. *Physica B: Condensed Matter* 1997; **341-243**:1197-1203.
- [43] Allman BE, McMahon PJ, Nugent KA, Paganin D, Jacobson DL, Arif M, Werner SA. Phase Radiography with Neutrons. *Nature* 2000; **408**:158-159.
- [44] Treimer W, Hilger A, Kardjilov N, Strobl M. Review About Old And New Imaging Signals For Neutron Computerized Tomography. *Nuclear Instruments & Methods in Physics Research, Section A (Accelerators, Spectrometers, Detectors and Associated Equipment)* 2005;**542**:367-375.
- [45] Kardjilov N, Manke I, Strobl M, Hilger A, Treimer W, Meissner M, Krist T, Banhart J. Three-Dimensional Imaging Of Magnetic Fields With Polarized Neutrons. *Nature Physics* 2008; **4**:399 – 403.