



ELSEVIER

Contents lists available at ScienceDirect

Journal of Combinatorial Theory,
Series Awww.elsevier.com/locate/jcta**(2 + 2)-free posets, ascent sequences and pattern avoiding permutations**Mireille Bousquet-Mélou^{a,1}, Anders Claesson^{b,2}, Mark Dukes^c,
Sergey Kitaev^{b,2}^a CNRS, LaBRI, Université Bordeaux 1, 351 cours de la Libération, 33405 Talence, France^b The Mathematics Institute, Reykjavik University, 103 Reykjavik, Iceland^c Science Institute, University of Iceland, 107 Reykjavik, Iceland

ARTICLE INFO

Article history:

Received 22 January 2009

Available online 4 January 2010

Keywords:

(2 + 2)-free poset

Ascent sequence

Pattern avoiding permutation

Chord diagram

Involution

Encode

Enumerate

Non-D-finite series

ABSTRACT

We present bijections between four classes of combinatorial objects. Two of them, the class of unlabeled $(2 + 2)$ -free posets and a certain class of involutions (or chord diagrams), already appeared in the literature, but were apparently not known to be equinumerous. We present a direct bijection between them. The third class is a family of permutations defined in terms of a new type of pattern. An attractive property of these patterns is that, like classical patterns, they are closed under the action of the symmetry group of the square. The fourth class is formed by certain integer sequences, called ascent sequences, which have a simple recursive structure and are shown to encode $(2 + 2)$ -free posets and permutations. Our bijections preserve numerous statistics.

We determine the generating function of these classes of objects, thus recovering a non-D-finite series obtained by Zagier for the class of chord diagrams. Finally, we characterize the ascent sequences that correspond to permutations avoiding the barred pattern $3\bar{1}524$ and use this to enumerate those permutations, thereby settling a conjecture of Pudwell.

© 2009 Elsevier Inc. All rights reserved.

E-mail address: anders@ru.is (A. Claesson).¹ MBM was supported by the French “Agence Nationale de la Recherche”, project SADA ANR-05-BLAN-0372.² AC and SK were supported by grant no. 060005012 from the Icelandic Research Fund.

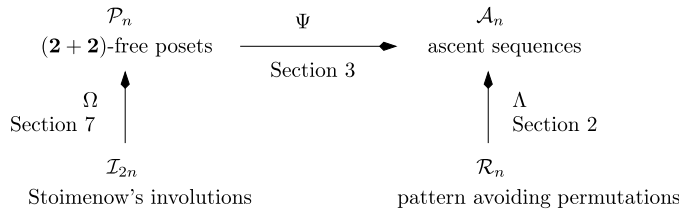

Fig. 1. The bijections of the paper.

1. Introduction

This paper presents correspondences (see Fig. 1) between three main structures, seemingly unrelated: unlabeled $(2 + 2)$ -free posets on n elements, certain fixed point free involutions (or chord diagrams) on $2n$ elements introduced by Stoimenow in connection with Vassiliev invariants of knots [20], and a new class of permutations on n letters. An auxiliary class of objects, consisting of certain sequences of nonnegative integers that we call *ascent sequences*, plays a central role in some of these correspondences. Indeed, we show that both our permutations and $(2 + 2)$ -free posets can be encoded as ascent sequences.

A poset is said to be $(2 + 2)$ -free if it does not contain an induced subposet that is isomorphic to $2 + 2$, the union of two disjoint 2-element chains. Fishburn [11] showed that a poset is $(2 + 2)$ -free precisely when it is isomorphic to an interval order. Amongst other results concerning $(2 + 2)$ -free posets [9,10,17,8], the following characterization plays an important role in this paper: a poset is $(2 + 2)$ -free if and only if the collection of strict principal down-sets can be linearly ordered by inclusion [4]. Precise definitions will be given in Sections 3 and 7.

The class of permutations we consider will be defined in Section 2, together with ascent sequences. Essentially, it is a class of permutations that *avoid* a particular pattern of length three. This type of pattern is new in the sense that it does not admit an expression in terms of the vincular³ patterns introduced by Babson and Steingrímsson [3]. An attractive property of these new patterns is that, like classical patterns, they are closed under the action of the symmetry group of the square. Vincular patterns do not enjoy this property. We show how to construct (and deconstruct) these permutations element by element, and how this gives a bijection Λ with ascent sequences.

In Section 3 we perform a similar task for $(2 + 2)$ -free posets. We present a recursive construction of these posets, more sophisticated than that of permutations, which gives a bijection Ψ with ascent sequences.

In Section 4 we present a simple algorithm that, given an ascent sequence x , computes what we call the modified ascent sequence, denoted \hat{x} . Some of the properties of the permutation and the poset corresponding to x are more easily read from \hat{x} than from x . We also explain how to go directly between a given poset and the corresponding permutation as opposed to via the ascent sequence. As an additional application of our machinery we show that the fixed points under $x \mapsto \hat{x}$ are in one-to-one correspondence with permutations avoiding the barred pattern $3\bar{1}524$. We use this characterization to count these permutations, thus proving a conjecture of Pudwell [16].

In Section 5 we prove that the bijections Λ and Ψ respect numerous natural statistics.

In Section 6 we determine the generating function of ascent sequences, and thus, of $(2 + 2)$ -free posets and pattern avoiding permutations. Several authors have tried to count these posets before [12,8,13], but did not obtain a closed expression for the generating function, which turns out to be a rather complicated, non-D-finite series. That our approach succeeds probably relies on the simple structure of ascent sequences.

³ Babson and Steingrímsson call these patterns “generalized” rather than “vincular”, but we wish to promote a change of terminology here, since vincular is more descriptive. The adjective vincular is derived from the Latin noun vinculum (“bond” in English).

The generating function we obtain for $(\mathbf{2} + \mathbf{2})$ -free posets has, however, already appeared in the literature: it was shown by Zagier [23] to count certain involutions (or chord diagrams) introduced by Stoimenow to give upper bounds on the dimension of the space of Vassiliev’s knot invariants of a given degree [20]. In Section 7 we present an alternative proof of Zagier’s result by giving a direct bijection Ω between $(\mathbf{2} + \mathbf{2})$ -free posets and Stoimenow’s involutions.

Finally, in Section 8 we state some natural questions.

Let us conclude with a few words on the genesis of this paper: we started with an investigation of permutations avoiding our new type of pattern. Patterns of length 2 being trivial, we moved to length 3, and discovered that the numbers counting one of our permutation classes formed the rather mysterious sequence A022493 of the on-line Encyclopedia of Integer Sequences [15]. From this arose the curiosity to clarify the connections between this class of permutations and $(\mathbf{2} + \mathbf{2})$ -free posets, but also between these posets and Stoimenow’s involutions, as this had apparently not been done before. We hope that the study of these new pattern-avoiding permutations will lead to other connections with interesting objects.

2. Ascent sequences and pattern avoiding permutations

Let (x_1, \dots, x_i) be an integer sequence. The number of *ascents* of this sequence is

$$\text{asc}(x_1, \dots, x_i) = |\{1 \leq j < i : x_j < x_{j+1}\}|.$$

Let us call a sequence $x = (x_1, \dots, x_n) \in \mathbb{N}^n$ an *ascent sequence of length n* if it satisfies $x_1 = 0$ and $x_i \in [0, 1 + \text{asc}(x_1, \dots, x_{i-1})]$ for all $2 \leq i \leq n$. For instance, $(0, 1, 0, 2, 3, 1, 0, 0, 2)$ is an ascent sequence. The length (number of entries) of a sequence x is denoted $|x|$.

Let S_n be the symmetric group on n elements. Let $V = \{v_1, v_2, \dots, v_n\}$ with $v_1 < v_2 < \dots < v_n$ be any finite subset of \mathbb{N} . The *standardisation* of a permutation π on V is the permutation $\text{std}(\pi)$ on $[n] := \{1, 2, \dots, n\}$ obtained from π by replacing the letter v_i with the letter i . As an example, $\text{std}(19452) = 15342$. Let \mathcal{R}_n be the following set of permutations:

$$\mathcal{R}_n = \{\pi_1 \dots \pi_n \in S_n : \text{if } \text{std}(\pi_i \pi_j \pi_k) = 231 \text{ then } j \neq i + 1 \text{ or } \pi_i \neq \pi_k + 1\}.$$

Equivalently, if $\pi_i \pi_{i+1}$ forms an ascent, then $\pi_i - 1$ is not found to the right of this ascent. This class of permutations could be more descriptively written as $\mathcal{R}_n = S_n(\begin{smallmatrix} \blacksquare & \blacksquare & \blacksquare \\ \blacksquare & \blacksquare & \blacksquare \\ \bullet & \bullet & \bullet \end{smallmatrix})$, the set of permutations *avoiding* the pattern in the diagram. Dark lines indicate adjacent entries (horizontally or vertically), whereas lighter lines indicate an elastic distance between the entries. Conversely, π *contains* this pattern if there exists $i < k$ such that $\pi_k + 1 = \pi_i < \pi_{i+1}$. As illustrated below, the permutation 31524 avoids the pattern $\begin{smallmatrix} \blacksquare & \blacksquare \\ \bullet & \bullet \end{smallmatrix}$ while the permutation 32541 contains it.

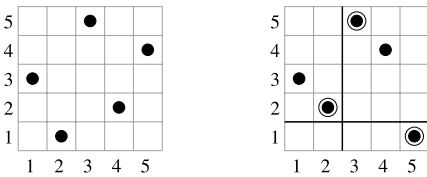

Clearly, this example can be generalized to any pattern consisting of a permutation plus some dark (vertical and horizontal) lines. Vertical lines represent a constraint of adjacency of the *positions*, while horizontal lines represent a constraint of adjacency of the *values*. When there is no dark line, we recover the standard notion of containment of a permutation. When only vertical lines are allowed, that is, constraints on the positions, we recover the *vincular* (or *generalized*) patterns of Babson and Steingrímsson [3]. For symmetry reasons, it seems natural to allow constraints on values as well, and this is precisely what our *bivincular patterns*, defined formally below, achieve.

Let us now give a formal definition of bivincular patterns. This is not needed for the rest of this paper, and the reader may, without loss of continuity, skip the next three paragraphs. We define a *bivincular permutation* (or *bivincular pattern*) to be a triple $p = (\sigma, X, Y)$, where σ is a permutation on

$[k]$ and X and Y are subsets of $[0, k]$. An occurrence of p in a permutation $\pi = \pi_1 \dots \pi_n$ on $[n]$ is subsequence $o = \pi_{i_1} \dots \pi_{i_k}$ such that $\text{std}(o) = \sigma$ and

$$\forall x \in X, \quad i_{x+1} = i_x + 1 \quad \text{and} \quad \forall y \in Y, \quad j_{y+1} = j_y + 1,$$

where $\{\pi_{i_1}, \dots, \pi_{i_k}\} = \{j_1, \dots, j_k\}$ and $j_1 < j_2 < \dots < j_k$; by convention, $i_0 = j_0 = 0$ and $i_{k+1} = j_{k+1} = n + 1$. With this definition we have $\mathcal{R}_n = \mathcal{S}_n((231, \{1\}, \{1\}))$. Note also that the number of bivincular permutations of length n is $4^{n+1}n!$.

The classical patterns are those of the form $p = (\sigma, \emptyset, \emptyset)$. Vincular patterns are of the form $p = (\sigma, X, \emptyset)$. Let $p = (\sigma, X_p, Y_p)$ and $q = (\tau, X_q, Y_q)$ be any two patterns. If σ and τ have the same length, we define their composition, or product, by $p \circ q = (\sigma \circ \tau, X_p \Delta Y_q, Y_p \Delta X_q)$, where $A \Delta B = (A - B) \cup (B - A)$ is the symmetric difference. This operation is not associative, but it admits a right identity, $(\text{id}, \emptyset, \emptyset)$, and every element $p = (\sigma, X, Y)$ has an inverse $p^{-1} = (\sigma^{-1}, Y, X)$; this turns the set of bivincular permutations of length n into a quasigroup with right identity. Also, reverse is defined by $p^r = (\sigma^r, n + 1 - X, Y)$ and complement is defined by $p^c = (\sigma^c, X, n + 1 - Y)$, in which $k - A$ denotes the set $\{k - a : a \in A\}$. Thus the set of bivincular patterns has the full symmetry of a square.

One simple instance of bivincular pattern avoidance that has already appeared in the literature is the set of *irreducible* permutations [1], that is, permutations such that $\pi_{i+1} \neq \pi_i - 1$ for all i . With our terminology, these are the permutations avoiding $(21, \{1\}, \{1\})$. Similarly, the *strongly irreducible* permutations of [2] are the $(21, \{1\}, \{1\})$ - and $(12, \{1\}, \{1\})$ -avoiding permutations.

Let us now return to the set $\mathcal{R} := \bigcup_n \mathcal{R}_n$ of permutations avoiding $(231, \{1\}, \{1\})$. Let π be a permutation of \mathcal{R}_n , with $n > 0$. Let τ be obtained by deleting the entry n from π . Then $\tau \in \mathcal{R}_{n-1}$. Indeed, if $\tau_i \tau_{i+1} \tau_j$ is an occurrence of the forbidden pattern in τ (but not in π), then this implies that $\pi_{i+1} = n$. But then $\pi_i \pi_{i+1} \pi_{j+1}$ would form an occurrence of the forbidden pattern in π .

This property allows us to construct the permutations of \mathcal{R}_n inductively, starting from the empty permutation and adding a new maximal value at each step. (This is the *generating tree* approach, systematized by West [21].) Given $\tau = \tau_1 \dots \tau_{n-1} \in \mathcal{R}_{n-1}$, the sites where n can be inserted in τ so as to produce an element of \mathcal{R}_n are called *active*. It is easily seen that the site before τ_1 and the site after τ_{n-1} are always active. The site between the entries τ_i and τ_{i+1} is active if and only if $\tau_i = 1$ or $\tau_i - 1$ is to the left of τ_i . Label the active sites, from left to right, with labels $0, 1, 2$ and so on. Observe that the site immediately to the left of the maximal entry of τ is always active.

Our bijection Λ between permutations of \mathcal{R}_n and ascent sequences of length n is defined recursively on n as follows. For $n = 1$, we set $\Lambda(1) = (0)$. Now let $n \geq 2$, and suppose that $\pi \in \mathcal{R}_n$ is obtained by inserting n in the active site labeled i of a permutation $\tau \in \mathcal{R}_{n-1}$. Then the sequence associated with π is $\Lambda(\pi) := (x_1, \dots, x_{n-1}, i)$, where $(x_1, \dots, x_{n-1}) = \Lambda(\tau)$.

Example 1. The permutation $\pi = 61832547$ corresponds to the sequence $x = (0, 1, 1, 2, 2, 0, 3, 1)$, since it is obtained by the following insertions (the subscripts indicate the labels of the active sites):

$$\begin{aligned} 01_1 &\xrightarrow{x_2=1} 01_1 2_2 \\ &\xrightarrow{x_3=1} 01_1 3_2 2_2 \\ &\xrightarrow{x_4=1} 01_1 3_2 2_2 4_3 \\ &\xrightarrow{x_5=1} 01_1 3_2 2_2 5_4 3_3 \\ &\xrightarrow{x_6=1} 06_1 1_1 3_2 2_2 5_4 3_3 \\ &\xrightarrow{x_7=1} 06_1 1_1 3_2 2_2 5_4 3_7 4_3 \\ &\xrightarrow{x_8=1} 6_1 1_8 3_3 2_2 5_4 7_3. \end{aligned}$$

Theorem 1. *The map Λ is a bijection from \mathcal{R}_n to the set of ascent sequences of length n .*

Proof. Since the sequence $\Lambda(\pi)$ encodes the construction of π , the map Λ is injective. We want to prove that the image of \mathcal{R}_n is the set \mathcal{A}_n of ascent sequences of length n . Let $s(\pi)$ denote the

number of active sites of the permutation π . Our recursive description of the map Λ tells us that $x = (x_1, \dots, x_n) \in \Lambda(\mathcal{R}_n)$ if and only if

$$x' = (x_1, \dots, x_{n-1}) \in \Lambda(\mathcal{R}_{n-1}) \quad \text{and} \quad 0 \leq x_n \leq s(\Lambda^{-1}(x')) - 1 \tag{1}$$

(recall that the leftmost active site is labeled 0, so that the rightmost one is $s(\pi) - 1$).

We will prove by induction on n that for all $\pi \in \mathcal{R}_n$, with associated sequence $\Lambda(\pi) = x = (x_1, \dots, x_n)$, one has

$$s(\pi) = 2 + \text{asc}(x) \quad \text{and} \quad b(\pi) = x_n, \tag{2}$$

where $b(\pi)$ is the label of the site located just before the maximal entry of π . Clearly, this will convert the above description (1) of $\Lambda(\mathcal{R}_n)$ into the definition of ascent sequences, thus concluding the proof.

So let us focus on the properties (2). They obviously hold for $n = 1$. Now assume they hold for some $n - 1$, with $n \geq 2$, and let $\pi \in \mathcal{R}_n$ be obtained by inserting n in the active site labeled i of $\tau \in \mathcal{R}_{n-1}$. Then $\Lambda(\pi) = x = (x_1, \dots, x_{n-1}, i)$ where $\Lambda(\tau) = x' = (x_1, \dots, x_{n-1})$. Every entry of π smaller than n is followed in π by an active site if and only if it was followed in τ by an active site. The leftmost site also remains active. Consequently, the label of the active site preceding n in π is $i = x_n$, which proves the second property. Thus, in order to determine $s(\pi)$, the only question is whether the site following n is active in π . There are two cases to consider. Recall that, by the induction hypothesis, $s(\tau) = 2 + \text{asc}(x')$ and $b(\tau) = x_{n-1}$.

Case 1: If $0 \leq i \leq b(\tau) = x_{n-1}$ then $\text{asc}(x) = \text{asc}(x')$ and the entry n in π is to the left of $n - 1$. So the number of active sites remains unchanged: $s(\pi) = s(\tau) = 2 + \text{asc}(x') = 2 + \text{asc}(x)$.

Case 2: If $i > b(\tau) = x_{n-1}$ then $\text{asc}(x) = 1 + \text{asc}(x')$ and the entry n in π is to the right of $n - 1$. The site that follows n is thus active, and $s(\pi) = 1 + s(\tau) = 3 + \text{asc}(x') = 2 + \text{asc}(x)$. This concludes the proof. \square

3. Ascent sequences and unlabeled $(2 + 2)$ -free posets

Let \mathcal{P}_n be the set of unlabeled $(2 + 2)$ -free posets on n elements. In this section we shall give a bijection between \mathcal{P}_n and the set \mathcal{A}_n of ascent sequences of length n . As in the previous section, this bijection encodes a recursive way of constructing $(2 + 2)$ -free posets by adding one new (maximal) element. There is of course a corresponding removal operation, but it is less elementary than in the case of permutations. Before giving these operations we need to define some terminology.

Let $D(x)$ be the set of *predecessors* of x (the strict down-set of x). Formally,

$$D(x) = \{y : y < x\}.$$

It is well known—see for example Bogart [4]—that a poset is $(2 + 2)$ -free if and only if its sets of predecessors, $\{D(x) : x \in P\}$, can be linearly ordered by inclusion. For completeness we prove this result here.

Lemma 2. *A poset P is $(2 + 2)$ -free if and only if the set of strict downsets of P can be linearly ordered by inclusion.*

Proof. If the set of strict downsets of P cannot be linearly ordered by inclusion, then there are two incomparable elements $x, y \in P$ such that both $D(x) \setminus D(y)$ and $D(y) \setminus D(x)$ are non-empty. Let $x' \in D(x) \setminus D(y)$ and $y' \in D(y) \setminus D(x)$. Then the induced subposet on the elements $\{x, x', y, y'\}$ is isomorphic to $(2 + 2)$. Conversely, if P contains an induced subposet $\{x > x', y > y'\}$ isomorphic to $(2 + 2)$, then $D(x)$ and $D(y)$ are such that both $D(x) \setminus D(y)$ and $D(y) \setminus D(x)$ are non-empty. \square

Let

$$D(P) = \{D_0, D_1, \dots, D_k\}$$

with $\emptyset = D_0 \subset D_1 \subset \dots \subset D_k$. In this context we define $D_i(P) = D_i$ and we write $\ell(P) = k$. We say the element x is at level i in P if $D(x) = D_i$ and we write $\ell(x) = i$. The set of all elements at level i we denote $L_i(P) = \{x \in P : \ell(x) = i\} = \{x \in P : D(x) = D_i\}$. For instance, $L_0(P)$ is the set of minimal elements. All the elements of $L_k(P)$ are maximal, but there may be maximal elements of P at level less than k . If $L_i(P)$ contains a maximal element, we say that *the level i contains a maximal element*. Let $\ell^*(P)$ be the minimum level containing a maximal element.

Example 2. Consider the following $(2 + 2)$ -free poset P , which we have labeled for convenience:

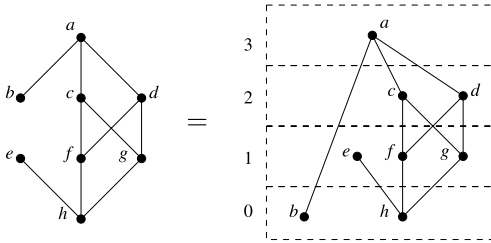

The diagram on the right shows the poset redrawn according to the levels of the elements. We have $D(a) = \{b, c, d, f, g, h\}$, $D(b) = \emptyset$, $D(c) = D(d) = \{f, g, h\}$, $D(e) = D(f) = D(g) = \{h\}$ and $D(h) = \emptyset$. These may be ordered by inclusion as

$$\underbrace{D(h) = D(b)} \subset \underbrace{D(e) = D(f) = D(g)} \subset \underbrace{D(c) = D(d)} \subset \underbrace{D(a)}$$

$$\ell(h) = \ell(b) = 0 \quad \ell(e) = \ell(f) = \ell(g) = 1 \quad \ell(c) = \ell(d) = 2 \quad \ell(a) = 3$$

Thus $\ell(P) = 3$. The maximal elements of P are e and a , and they lie respectively at levels 3 and 1. Thus $\ell^*(P) = 1$. In addition, $D_0 = \emptyset$, $D_1 = \{h\}$, $D_2 = \{f, g, h\}$ and $D_3 = \{b, c, d, f, g, h\}$. With $L_i = L_i(P)$ we also have $L_0 = \{h, b\}$, $L_1 = \{e, f, g\}$, $L_2 = \{c, d\}$ and $L_3 = \{a\}$.

3.1. Removing an element from a $(2 + 2)$ -free poset

Let us begin with the removal operation, which will be the counterpart of the deletion of the last entry in an ascent sequence (or the deletion of the largest entry in a permutation of \mathcal{R}). Let P be a $(2 + 2)$ -free poset of cardinality $n \geq 2$, and let $i = \ell^*(P)$ be the minimum level of P containing a maximal element. All the maximal elements located at level i are order-equivalent in the unlabeled poset P . We will remove one of them. Let Q be the poset that results from applying:

- (Rem1) If $|L_i(P)| > 1$ then simply remove one of the maximal elements at level i .
- (Rem2) If $|L_i(P)| = 1$ and $i = \ell(P)$ then remove the unique element lying at level i .
- (Rem3) If $|L_i(P)| = 1$ and $i < \ell(P)$ then set $\mathcal{N} = D_{i+1}(P) \setminus D_i(P)$. Make each element in \mathcal{N} a maximal element of the poset by deleting from the order all relations $x < y$ where $x \in \mathcal{N}$. Finally, remove the unique element lying at level i .

Example 3. Let P be the unlabeled $(2 + 2)$ -free poset with this Hasse diagram:

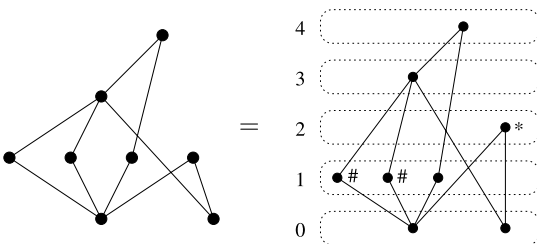

The diagram on the right shows the poset redrawn according to the levels of the elements. There is a unique maximal element of minimal level, which is marked with * and lies at level 2, so that $\ell^*(P) = 2$. Since there is a unique element at level $2 < \ell(P)$, apply Rem3 to remove it. The elements of \mathcal{N} are indicated by #'s. In order to delete all relations of the form $x < y$ where $x \in \mathcal{N}$, one deletes from the Hasse diagram all edges corresponding to coverings of elements of \mathcal{N} , and adds an edge between the elements at level 0 and 3 to preserve their relation. Finally, one removes the element at level 2. This gives a new $(2 + 2)$ -free poset, with level numbers shown on the left.

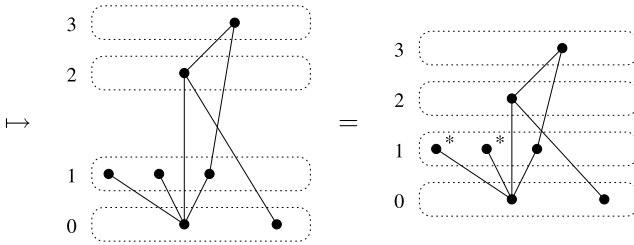

There are now two maximal elements of minimal level $\ell^* = 1$, both marked by *. Remove one of them according to rule Rem1. This gives the poset shown on the left below, for which ℓ^* is still 1. Apply Rem1 again to obtain the poset on the right.

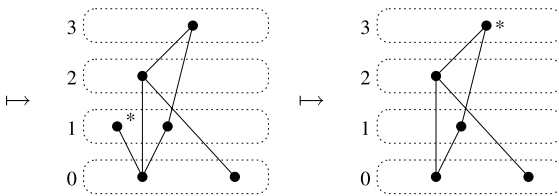

There is now a single maximal element, lying at maximal level 3, so we apply rule Rem2:

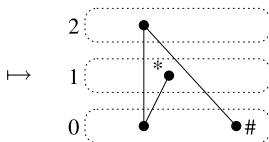

The maximal element of minimal level is now alone on level $\ell^*(P) = 1 < \ell(P)$ so apply Rem3. The set \mathcal{N} consists of the rightmost point at level 0, giving

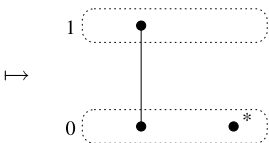

The maximal element of minimal level is not alone at level 0, so apply Rem1:

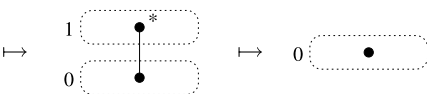

We have thus reduced the original poset P to a one element poset by removing the elements in a canonical order.

Let us now check that the removal operation gives a $(\mathbf{2} + \mathbf{2})$ -free poset, and establish some elementary properties of this operation. If $\ell^*(P) = i$, and the removal operation, applied to P , gives Q , we define $\psi(P) = (Q, i)$.

Lemma 3. *If $n \geq 2$, $P \in \mathcal{P}_n$ and $\psi(P) = (Q, i)$, then $Q \in \mathcal{P}_{n-1}$ and $0 \leq i \leq 1 + \ell(Q)$. Also,*

$$\ell(Q) = \begin{cases} \ell(P) & \text{if } i \leq \ell^*(Q), \\ \ell(P) - 1 & \text{if } i > \ell^*(Q). \end{cases}$$

Proof. We examine separately the 3 cases described above.

If $|L_i(P)| > 1$ then one simply removes a maximal element at level i to obtain Q : the set of sets of predecessors is unchanged, and remains linearly ordered. Hence $Q \in \mathcal{R}_{n-1}$. Also, $\ell(Q) = \ell(P)$. The maximal elements of Q were already maximal in P . Thus the maximal elements of lowest level in Q are at level i at least, that is, $\ell^*(Q) \geq i$.

If $|L_i(P)| = 1$ and $i = \ell(P)$, one removes the unique element of maximal level. One has now $D(Q) = D(P) \setminus \{D_i(P)\}$, which is still linearly ordered. Also, $\ell(Q) = \ell(P) - 1$. In particular, $i = \ell(Q) + 1 > \ell^*(Q)$.

Finally, if $|L_i(P)| = 1$ and $i < \ell(P)$, define the set \mathcal{N} as in Rem3. By construction, the set of sets of predecessors of Q is

$$D(Q) = \{D_0(P), \dots, D_{i-1}(P), D_{i+1}(P) \setminus \mathcal{N}, \dots, \ell(P)(P) \setminus \mathcal{N}\}.$$

To prove that $D(Q)$ can be linearly ordered, it suffices to prove that $D_{i-1}(P) \subset D_{i+1}(P) \setminus \mathcal{N}$. By definition, $\mathcal{N} = D_{i+1}(P) \setminus D_i(P)$ and hence

$$\begin{aligned} D_{i+1}(P) \setminus \mathcal{N} &= D_{i+1}(P) \setminus (D_{i+1}(P) \setminus D_i(P)) \\ &= D_{i+1}(P) \cap D_i(P) \\ &= D_i(P) \\ &\supset D_{i-1}(P). \end{aligned}$$

It is also clear that $\ell(Q) = \ell(P) - 1$. The elements of \mathcal{N} are maximal in Q and lie at level $< i$. Hence $\ell^*(Q) < i$. \square

3.2. Adding an element to a $(\mathbf{2} + \mathbf{2})$ -free poset

Let us now define the addition operation, which adds a maximal element to a $(\mathbf{2} + \mathbf{2})$ -free poset Q .

Given $Q \in \mathcal{P}_{n-1}$ and $0 \leq i \leq 1 + \ell(Q)$, let $\varphi(Q, i)$ be the poset P obtained from Q according to the following:

- (Add1) If $i \leq \ell^*(Q)$ then introduce a new maximal element which covers the same elements as the elements of $L_i(Q)$.
- (Add2) If $i = 1 + \ell(Q)$, add a new element covering all maximal elements of Q .
- (Add3) If $\ell^*(Q) < i \leq \ell(Q)$, add a new element covering the same elements as the elements of $L_i(Q)$.
Let \mathcal{M} be the set of maximal elements of Q of level less than i . Add all relations $x \leq y$ where $x \leq z$ for some $z \in \mathcal{M}$ and $y \in L_i(Q) \cup \dots \cup L_{\ell(Q)}(Q)$. In particular, every element of \mathcal{M} is now covered by every minimal element of the poset induced by $L_i(Q) \cup \dots \cup L_{\ell(Q)}(Q)$.

Example 4. Starting from the one-element poset, we add successively 7 points according to the rules above, where the parameter i takes the following values: $i = 1, 2, 3, 1, 0, 1, 2$. Note that the sequence

(0, 1, 2, 3, 1, 0, 1, 2) is an ascent sequence. This is of course not an accident. For each step, the new element is circled.

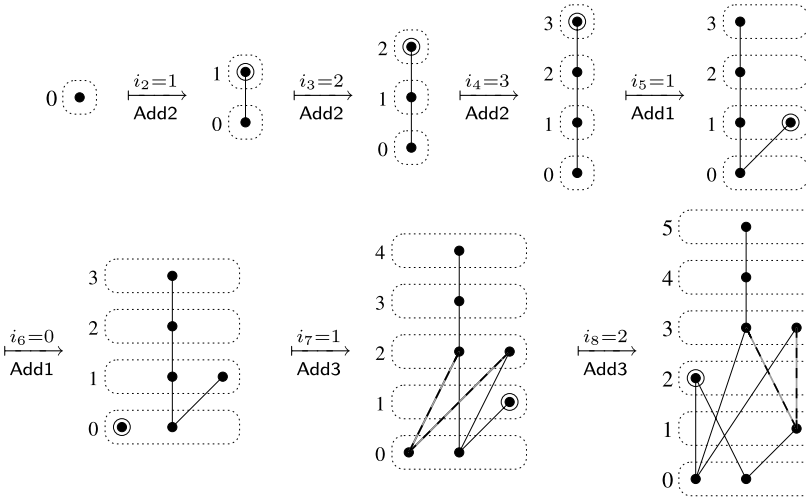

In the final two steps, where the operation Add3 is used, we have inserted dashed lines indicating the covering of the elements of \mathcal{M} . Observe that in a last step, the addition of these new coverings makes two edges of the next-to-last diagram transitive: they do not appear any more in the final diagram.

Let us now check that the addition operation gives a $(2 + 2)$ -free poset, and establish some elementary properties of this operation.

Lemma 4. *If $n \geq 2$, $Q \in \mathcal{P}_{n-1}$, $0 \leq i \leq 1 + \ell(Q)$ and $P = \varphi(Q, i)$, then $P \in \mathcal{P}_n$. Also,*

$$\ell^*(P) = i \text{ and } \ell(P) = \begin{cases} \ell(Q) & \text{if } i \leq \ell^*(Q), \\ \ell(Q) + 1 & \text{if } i > \ell^*(Q). \end{cases}$$

Proof. We examine separately the 3 cases described above.

If $i \leq \ell^*(Q)$, then Add1 is used. We want to show that the set $D(P) = \{D(x) : x \in P\}$ of sets of predecessors can be linearly ordered. This is however trivial: By definition of Add1 we have $D(P) = D(Q)$ which is linearly ordered. The set of predecessors of the new element is $D_i(Q)$, so it lies at level i . As this element is maximal, and its level i is not larger than $\ell^*(Q)$, we have $\ell^*(P) = i$. Finally, it follows from $D(P) = D(Q)$ that $\ell(P) = \ell(Q)$.

If $i = 1 + \ell(Q)$, then Add2 is used. The set $D(P)$ is $D(Q) \cup \{Q\}$, which is still linearly ordered by inclusion. The highest level increases by one: $\ell(P) = \ell(Q) + 1$. Finally, the new element is the only maximal element of P , so that $\ell^*(P) = \ell(P) = 1 + \ell(Q) = i$.

If $\ell^*(Q) < i \leq \ell(Q)$, then Add3 is used. The new element has set of predecessors $D_i(Q)$. The elements that had level i or more in Q now include the elements of \mathcal{M} among their predecessors. Consequently,

$$D(P) = \{D_0(Q), \dots, D_i(Q), D_i(Q) \cup \mathcal{M}, D_{i+1}(Q) \cup \mathcal{M}, \dots, D_{\ell(Q)}(Q) \cup \mathcal{M}\}, \tag{3}$$

which is linearly ordered. From this expression for $D(P)$ we also see that $\ell(P) = \ell(Q) + 1$, as claimed. Moreover, as all elements of level less than i in Q are now covered, the new element is the only maximal element of minimal level, so that $\ell^*(P) = i$. \square

Let us now prove the compatibility of our removal and addition operations.

Lemma 5. For any $(2 + 2)$ -free poset Q and integer i such that $0 \leq i \leq 1 + \ell(Q)$ we have $\psi(\varphi(Q, i)) = (Q, i)$. And if Q has more than one element we also have $\varphi(\psi(Q)) = Q$.

Proof. Let us begin with the first statement, and denote $P = \varphi(Q, i)$. Recall that $\ell^*(P) = i$, so that the removal operation applied to P takes out an element of level i and gives $\psi(P) = (R, i)$. We want to prove that $R = Q$.

Assume that $i \leq \ell^*(Q)$ so that Add1 is used to construct P from Q . The new element is introduced at level i and is not alone at this level. Thus the removal operation Rem1 is applied to P , and simply removes one maximal element at level i —either the one that was added, or another, order-equivalent, one. Thus Q and R coincide, as unlabeled posets.

Assume that $i = 1 + \ell(Q)$ so that Add2 is used. The new element is the only maximal element in P , so that the removal operation Rem2 is applied to P , and simply removes this maximal element. Thus again, $R = Q$.

Assume that $\ell^*(Q) < i \leq \ell(Q)$ so that Add3 is used. The new element is maximal, and is the only element at level $i < \ell(P) = 1 + \ell(Q)$. Thus it will be removed using Rem3. Let \mathcal{M} be the set of maximal elements of Q of level less than i . The set \mathcal{N} that occurs in the description of Rem3 is $D_{i+1}(P) \setminus D_i(P)$. According to (3), this set coincides with \mathcal{M} . Hence the covering relations that were added to go from Q to P are now destroyed when going from P to R . Thus $R = Q$.

A similar argument (with the two transformations interchanged) gives the second statement of the lemma. \square

3.3. From $(2 + 2)$ -free posets to ascent sequences

Our bijection Ψ between $(2 + 2)$ -free posets of cardinality n and ascent sequences of length n is defined recursively on n as follows. For $n = 1$, we associate with the one-element poset the sequence (0) . Now let $n \geq 2$, and suppose that the removal operation, applied to $P \in \mathcal{P}_n$, gives $\psi(P) = (Q, i)$. In other words, P is obtained from Q by adding a new maximal element at level i , following our addition procedure. Then the sequence associated with P is $\Psi(P) := (x_1, \dots, x_{n-1}, i)$, where $(x_1, \dots, x_{n-1}) = \Psi(Q)$.

For instance, the poset of Example 3 corresponds to the sequence $(0, 1, 0, 1, 3, 1, 1, 2)$, while the poset of Example 4 corresponds to the sequence $(0, 1, 2, 3, 1, 0, 1, 2)$.

Theorem 6. The map Ψ is a one-to-one correspondence between $(2 + 2)$ -free posets of size n and ascent sequences of length n .

Proof. Since the sequence $\Psi(P)$ encodes the construction of the poset P , the map Ψ is injective. We want to prove that the image of \mathcal{P}_n is the set \mathcal{A}_n of ascent sequences of length n . Our recursive description of the map Ψ tells us that $x = (x_1, \dots, x_n) \in \Psi(\mathcal{P}_n)$ if and only if

$$x' = (x_1, \dots, x_{n-1}) \in \Psi(\mathcal{P}_{n-1}) \quad \text{and} \quad 0 \leq x_n \leq 1 + \ell(\Psi^{-1}(x')). \tag{4}$$

We will prove by induction on n that for all $P \in \mathcal{P}_n$, with associated sequence $\Psi(P) = x = (x_1, \dots, x_n)$, one has

$$\ell(P) = \text{asc}(x) \quad \text{and} \quad \ell^*(P) = x_n. \tag{5}$$

Clearly, this will convert the above description (4) of $\Psi(\mathcal{P}_n)$ into the definition of ascent sequences, thus concluding the proof.

So let us focus on the properties (5). They obviously hold for $n = 1$. Now assume they hold for some $n - 1$, with $n \geq 2$, and let $P \in \mathcal{P}_n$ be obtained by adding a new element at level i in $Q \in \mathcal{P}_{n-1}$. Then $\Psi(P) = x = (x_1, \dots, x_{n-1}, i)$ where $\Psi(Q) = x' = (x_1, \dots, x_{n-1})$. By the induction hypothesis, $\ell(Q) = \text{asc}(x')$ and $\ell^*(Q) = x_{n-1}$. Lemma 4 gives $\ell^*(P) = i$ and

$$\ell(P) = \begin{cases} \text{asc}(x') & \text{if } i \leq x_{n-1}, \\ \text{asc}(x') + 1 & \text{if } i > x_{n-1}. \end{cases}$$

The result follows. \square

4. Modified ascent sequences and their applications

In this section we introduce a transformation on ascent sequences and show some applications. For instance, this transformation can be used to give a non-recursive description of the bijection Δ between permutations of \mathcal{R} and ascent sequences. It is also useful to characterize the image by Δ of a subclass of \mathcal{R} studied by Pudwell [16], which we enumerate. We also describe how to transform $(2 + 2)$ -free posets into permutations, without resorting to ascent sequences.

4.1. Modified ascent sequences

Let $x = (x_1, x_2, \dots, x_n)$ be any finite sequence of integers. We denote by $\text{asc}(x)$ the (ordered) list of positions where an ascent occurs:

$$\text{asc}(x) = (i: i \in [n - 1] \text{ and } x_i < x_{i+1});$$

so $\text{asc}(x) = |\text{asc}(x)|$. In terms of an algorithm we shall now describe a function from integer sequences to integer sequences. Let $x = (x_1, x_2, \dots, x_n)$ be the input sequence and suppose that $\text{asc}(x) = (a_1, \dots, a_k)$. Do

```
for  $i = a_1, \dots, a_k$ :
  for  $j = 1, \dots, i - 1$ :
    if  $x_j \geq x_{i+1}$  then  $x_j := x_j + 1$ 
```

and denote the resulting sequence by \hat{x} . Assuming that x is an ascent sequence we call \hat{x} the *modified ascent sequence*. As an example, consider the ascent sequence $x = (0, 1, 0, 1, 3, 1, 1, 2)$. We have $\text{asc}(x) = (1, 3, 4, 7)$ and the algorithm computes the modified ascent sequence \hat{x} in the following steps:

$$\begin{aligned} x &= 0 \mathbf{1} 0 1 3 1 1 2 \\ &\quad 0 1 0 \mathbf{1} 3 1 1 2 \\ &\quad 0 2 0 1 \mathbf{3} 1 1 2 \\ &\quad 0 2 0 1 3 1 \mathbf{1} 2 \\ &\quad 0 3 0 1 4 1 1 2 = \hat{x}. \end{aligned}$$

In each step every element strictly to the left of and weakly larger than the boldface letter is incremented by one. Observe that the positions of ascents in x and \hat{x} coincide, and that the number of ascents in x (or \hat{x}) is $\text{asc}(x) = \text{asc}(\hat{x}) = \max(\hat{x})$. The above procedure is easy to invert:

```
for  $i = a_k, \dots, a_1$ :
  for  $j = 1, \dots, i - 1$ :
    if  $x_j > x_{i+1}$  then  $x_j := x_j - 1$ 
```

Thus the map $x \mapsto \hat{x}$ is injective.

We can also construct modified ascent sequences recursively as follows: the only such sequence of length 1 is (0). For $n \geq 2$, (y_1, \dots, y_n) is a modified ascent sequence if, and only if,

- $0 \leq y_n \leq y_{n-1}$ and (y_1, \dots, y_{n-1}) is a modified ascent sequence, or
- $y_{n-1} < y_n \leq 1 + \text{asc}(y_1, \dots, y_{n-1})$, $y_j \neq y_n$ for all $j < n$, and

$$(y_1 - \epsilon_1, \dots, y_{n-1} - \epsilon_{n-1})$$

is a modified ascent sequence, where $\epsilon_j = 1$ if $y_j \geq y_n$, and $\epsilon_j = 0$ otherwise.

The modified ascent sequence \hat{x} is related to the level distribution of the poset P associated with x . First, observe that the removal operation of Section 3.1 induces a canonical labelling of the size n

poset P by elements of $[n]$: the first element that is removed gets label n , and so on. Applying this to the poset of Example 3 we get the following labelling:

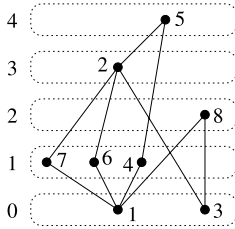

The following lemma is easily proved by induction, by combining the descriptions of the map $x \mapsto \widehat{x}$ and of the recursive bijection between ascent sequences and $(2 + 2)$ -free posets.

Lemma 7. *Let P be a $(2 + 2)$ -free poset equipped with its canonical labelling. Let x be the associated ascent sequence, and $\widehat{x} = (\widehat{x}_1, \dots, \widehat{x}_n)$ the corresponding modified ascent sequence. Then for all $i \leq n$, the element i of the poset lies at level \widehat{x}_i .*

For instance, listing the elements of the poset above and their respective levels gives

$$\begin{matrix} 1 & 2 & 3 & 4 & 5 & 6 & 7 & 8 \\ 0 & 3 & 0 & 1 & 4 & 1 & 1 & 2 \end{matrix} = \widehat{x},$$

where we recognize the modified ascent sequence of $(0, 1, 0, 1, 3, 1, 1, 2) = \Psi(P)$.

4.2. From posets to permutations

The canonical labelling of the poset P can also be used to set up the bijection from $(2 + 2)$ -free posets to permutations of \mathcal{R} without using ascent sequences. We read the elements of the poset by increasing level, and, for a fixed level, in descending order of their labels. This gives a permutation $f(P)$. In our example we get 31764825, which is the permutation of \mathcal{R}_8 associated with the ascent sequence $(0, 1, 0, 1, 3, 1, 1, 2) = \Psi(P)$. Let us prove that this works in general.

Proposition 8. *For any $(2 + 2)$ -free poset P equipped with its canonical labelling, the permutation $f(P)$ described above is the permutation of \mathcal{R} corresponding to the ascent sequence $\Psi(P)$. In other words,*

$$\Lambda^{-1} \circ \Psi(P) = \widehat{L}_0 \widehat{L}_1 \dots \widehat{L}_{\ell(P)} := \pi,$$

where \widehat{L}_j is the word obtained by reading the elements of $L_j(P)$ in decreasing order. Moreover, the active sites of the above permutation are those preceding and following π , as well as the sites separating two consecutive factors \widehat{L}_j .

Proof. We proceed by induction on the size of P . The base case $n = 1$ is easy to check. So let $n \geq 2$, and assume the proposition holds for $n - 1$. Let $P \in \mathcal{P}_n$ be obtained by inserting a new maximal element at level i in $Q \in \mathcal{P}_{n-1}$. By the induction hypothesis, the permutation corresponding to Q is

$$\tau = \widehat{L}'_0 \widehat{L}'_1 \dots \widehat{L}'_{\ell(Q)},$$

where \widehat{L}'_j is obtained by reading in decreasing order the elements of $L_j(Q)$. Returning to the description of the addition operation, we see that, if $i \leq \ell^*(Q)$,

$$\widehat{L}'_j = \begin{cases} \widehat{L}'_j & \text{if } j \neq i, \\ \{n\} \cup \widehat{L}'_i & \text{if } j = i, \end{cases}$$

while if $i > \ell^*(Q)$,

$$\widehat{L}_j = \begin{cases} \widehat{L}'_j & \text{if } j < i, \\ \{n\} & \text{if } j = i, \\ \widehat{L}'_{j-1} & \text{if } j > i. \end{cases}$$

In both cases, the word obtained by reading the elements of P is

$$f(P) = \widehat{L}'_0 \dots \widehat{L}'_{i-1} n \widehat{L}'_i \widehat{L}'_{i+1} \dots \widehat{L}'_{\ell(Q)},$$

which is obtained by inserting n in the active site labeled i of τ . Hence $f(P) = \Lambda^{-1} \circ \Psi(P)$. It is then easy to check that the active sites of $f(P)$ are indeed those separating the factors \widehat{L}_j , and those preceding and following $f(P)$. \square

4.3. From ascent sequences to permutations, and vice-versa

By combining Lemma 7 and Proposition 8, we obtain a non-recursive description of the bijection between ascent sequences and permutations of \mathcal{R} . Let x be an ascent sequence, and \widehat{x} its modified sequence. Take the sequence \widehat{x} and write the numbers 1 through n below it. In our running example, $x = (0, 1, 0, 1, 3, 1, 1, 2)$, this gives

$$\begin{array}{cccccccc} \widehat{x} = & 0 & 3 & 0 & 1 & 4 & 1 & 1 & 2 \\ & 1 & 2 & 3 & 4 & 5 & 6 & 7 & 8. \end{array}$$

Let P be the poset associated with x . By Lemma 7, the element labeled i in P lies at level \widehat{x}_i . This information is not sufficient to reconstruct the poset P but it is sufficient to reconstruct the word $f(P)$ obtained by reading the elements of P by increasing level: Sort the pairs $\binom{\widehat{x}_i}{i}$ in ascending order with respect to the top entry and break ties by sorting in descending order with respect to the bottom entry. In the above example, this gives

$$\begin{array}{cccccccc} 0 & 0 & 1 & 1 & 1 & 2 & 3 & 4 \\ 3 & 1 & 7 & 6 & 4 & 8 & 2 & 5. \end{array}$$

By Proposition 8, the bottom row, here 31764825, is the permutation $\Lambda^{-1}(x)$. We have thus established the following direct description of Λ^{-1} .

Corollary 9. *Let x be an ascent sequence. Sorting the pairs $\binom{\widehat{x}_i}{i}$ in the order described above gives the permutation $\pi = \Lambda^{-1}(x)$. Moreover, the number of entries of π between the active sites i and $i + 1$ is the number of entries of \widehat{x} equal to i , for all $i \geq 0$.*

The second statement gives a non-recursive way of deriving $x = \Lambda(\pi)$ (or, rather, \widehat{x}) from π . Take a permutation $\pi \in \mathcal{R}_n$, and indicate its actives sites. For instance, $\pi = {}_031_1764_28_324_55$. Write the letter i below all entries π_j that lie between the active site labeled i and the active site labeled $i + 1$:

$$\begin{array}{cccccccc} 3 & 1 & 7 & 6 & 4 & 8 & 2 & 5 \\ 0 & 0 & 1 & 1 & 1 & 2 & 3 & 4. \end{array}$$

Then sort the pairs $\binom{\pi_j}{i}$ by increasing order of the π_j :

$$\begin{array}{cccccccc} 1 & 2 & 3 & 4 & 5 & 6 & 7 & 8 \\ 0 & 3 & 0 & 1 & 4 & 1 & 1 & 2. \end{array}$$

We have recovered, on the bottom row, the modified ascent sequence \widehat{x} corresponding to π .

4.4. Permutations avoiding $3\bar{1}52\bar{4}$ and self modified ascent sequences

A permutation π avoids the barred pattern $3\bar{1}52\bar{4}$ if every occurrence of the (classical) pattern 231 plays the role of 352 in an occurrence of the (classical) pattern 31524. In other words, for every $i < j < k$ such that $\pi_k < \pi_i < \pi_j$, there exists $\ell \in (i, j)$ and $m > k$ such that $\pi_i\pi_\ell\pi_j\pi_k\pi_m$ is an occurrence of 31524. Note that every such permutation avoids the pattern $\begin{matrix} \bullet & \bullet \\ \bullet & \bullet \end{matrix}$, and thus belongs to the set \mathcal{R} . Permutations avoiding $3\bar{1}52\bar{4}$ were considered by Pudwell, who gave a conjecture for their enumeration [16, p. 84]. Here, we describe the ascent sequences corresponding to these permutations via the bijection Λ . Then, we use this description to settle Pudwell’s conjecture.

An ascent sequence x is *self modified* if it is fixed by the map $x \mapsto \widehat{x}$ defined above. For instance, $(0, 0, 1, 0, 2, 2, 0, 3, 1, 1)$ is self modified. In view of the definition of the map $x \mapsto \widehat{x}$, this means that, if $x_{i+1} > x_i$, then $x_j < x_{i+1}$ for all $j \leq i$. Recall that $\text{asc}(x) = \max(\widehat{x})$. Combining this with the condition defining ascent sequences, we see that (x_1, \dots, x_n) is a self modified ascent sequence if and only if $x_1 = 0$ and, for all $i \geq 1$, either $x_{i+1} \leq x_i$ or $x_{i+1} = 1 + \max\{x_j : j \leq i\}$. Consequently, a modified ascent sequence x with $\max(x) = k$ reads $0A_01A_12A_2 \dots kA_k$, where A_i is a (possibly empty) weakly decreasing factor, and each element of A_i is less than or equal to i .

Proposition 10. *The ascent sequence x is self modified if and only if the corresponding permutation π avoids $3\bar{1}52\bar{4}$. In this case, $\max(x) = \text{asc}(\pi) = \text{rmin}(\pi) - 1$, where $\text{rmin}(\pi)$ is the number of right-to-left minima of π , that is, the number of i such that $\pi_i < \pi_j$ for all $j > i$.*

Proof. We proceed by induction on the size n of the permutations. The statement is obvious for $n = 1$, so let $n \geq 2$, and assume it holds for $n - 1$. Let $\pi \in \mathcal{R}_n$ be obtained by inserting n in the active site labeled i of $\tau \in \mathcal{R}_{n-1}$. Let $x' = (x_1, \dots, x_{n-1})$ be the ascent sequence $\Lambda(\tau)$. The ascent sequence $\Lambda(\pi)$ is $x = (x_1, \dots, x_{n-1}, i)$.

First, assume π avoids $3\bar{1}52\bar{4}$, and let us prove that x is self modified. Note that τ avoids $3\bar{1}52\bar{4}$, because the largest entry in this pattern is not barred. By the induction hypothesis, the ascent sequence $x' = \Lambda(\tau)$ is self modified. Assume, *ab absurdo*, that x is not self modified. This means that $x_{n-1} < i < 1 + \text{asc}(x')$. That is, n is inserted to the right of $n - 1$, but not to the extreme right of τ . Then the entries $n - 1, n, \pi_n$ form an occurrence of 231 which does not play the role of 352 in an occurrence of 31524 (the $\bar{4}$ is missing). This contradicts the assumption that π avoids $3\bar{1}52\bar{4}$. Hence x is self modified.

Conversely, assume that x is self modified (so that x' itself is self modified), and let us prove that π avoids $3\bar{1}52\bar{4}$. By the induction hypothesis, τ avoids $3\bar{1}52\bar{4}$. Assume, *ab absurdo*, that π contains an occurrence of $3\bar{1}52\bar{4}$. Then this occurrence must contain the entry n , playing the role of 3 in 231. Let $\pi_j\pi_k\pi_\ell$ be such an occurrence, with $n = \pi_k$. Obviously, n is not inserted to the extreme right of τ , so that $i \leq x_{n-1}$. Moreover, either there is no entry smaller than π_ℓ between π_j and n (the entry $\bar{1}$ is missing), or there is no entry larger than π_j to the right of π_ℓ (the entry $\bar{4}$ is missing). In the first case, $\pi_{k-1}\pi_k\pi_\ell$ is another occurrence of $3\bar{1}52\bar{4}$. Since n is inserted in an active site, $\pi_{k-1} - 1$ occurs before π_{k-1} , but then $(\pi_{k-1} - 1)\pi_k\pi_\ell$ forms an occurrence of $3\bar{1}52\bar{4}$ in τ , a contradiction. In the second case, $\pi_j(n - 1)\pi_\ell$ forms an occurrence of $3\bar{1}52\bar{4}$ in τ , because $n - 1$ is to the right of n . This gives a contradiction again. Hence π avoids $3\bar{1}52\bar{4}$.

Still under the assumption that x is self modified, observe that the number of ascents, and the number of right-to-left minima, increase by one when going from τ to π if $i = 1 + \text{asc}(x')$. If $i \leq x_{n-1}$, then n is inserted in an ascent of τ (otherwise the insertion would create a forbidden pattern), so that the number of ascents is left unchanged. The same holds for the number of right-to-left minima. \square

Proposition 11. *The length generating function of $3\bar{1}52\bar{4}$ -avoiding permutations is*

$$\sum_{k \geq 1} \frac{t^k}{(1-t)^{\binom{k+1}{2}}}$$

Equivalently, the number of such permutations of length n is

$$\sum_{k=1}^n \binom{\binom{k}{2} + n - 1}{n - k}.$$

Moreover, the k -th term of this sum counts those permutations that have k right-to-left minima, or, equivalently, $k - 1$ ascents. This is also the number of self modified ascent sequences of length n with largest element $k - 1$.

The corresponding numbers form Sequence A098569 in the OEIS [15].

Proof. By Proposition 10, permutations of length n avoiding $3\bar{1}52\bar{4}$ and having $k - 1$ ascents are in bijection with self modified ascent sequences of length n and largest entry $k - 1$. As discussed above, such sequences read

$$x = 0A_01A_12A_2 \dots (k - 1)A_{k-1},$$

where A_i is a (possibly empty) weakly decreasing factor, and each element of A_i is less than or equal to i . That is,

$$A_i = A_i^{(i)} A_i^{(i-1)} \dots A_i^{(0)},$$

where the factor $A_i^{(j)}$, for $j \leq i$, consists of letters j only. Let $\ell_i^{(j)}$ be the length of this factor. Clearly, there are $1 + 2 + \dots + k = \binom{k+1}{2}$ factors $A_i^{(j)}$ in x , which may be empty. The list $(\ell_0^{(0)}, \ell_1^{(1)}, \ell_1^{(0)}, \dots, \ell_{k-1}^{(0)})$ determines x completely, and forms a composition of $n - k$ in $\binom{k+1}{2}$ (possibly empty) parts. Thus the number of such sequences x is

$$\binom{n - k + \binom{k+1}{2} - 1}{n - k} = \binom{\binom{k}{2} + n - 1}{n - k}$$

as claimed. \square

5. Statistics

We shall now look at statistics on ascent sequences, permutations and posets—statistics that we can translate between using our bijections.

Let $x = (x_1, x_2, \dots, x_n)$ be any sequence of nonnegative integers. Let $\text{last}(x) = x_n$. Define $\text{zeros}(x)$ as the number of zeros in x . A *right-to-left maximum* of x is a letter with no larger letter to its right; the number of right-to-left maxima is denoted $\text{rmax}(x)$. For example,

$$\text{rmax}(0, 1, 0, \mathbf{2}, 0, \mathbf{2}, 0, \mathbf{1}) = 3;$$

the right-to-left maxima are in bold. The statistics *right-to-left minima* (rmin), *left-to-right maxima* (lmax), and *left-to-right minima* (lmin) are defined similarly. For sequences x and y of nonnegative integers, let $x \oplus y = xy'$, where y' is obtained from y by adding $1 + \max(x)$ to each of its letters, and juxtaposition denotes concatenation. For example, $(0, 2, 0, 1) \oplus (0, 0) = (0, 2, 0, 1, 3, 3)$. We say that a sequence x has k components if it is the sum of k , but not $k + 1$, non-empty nonnegative sequences. Note that $y \oplus z$ is a modified ascent sequence (as defined in Section 4) if and only if y and z are themselves modified ascent sequences. This is the case in the above example.

For permutations π and σ , let $\pi \oplus \sigma = \pi\sigma'$, where σ' is obtained from σ by adding $|\pi|$ to each of its letters. We say that π has k components if it is the sum of k , but not $k + 1$, non-empty permutations. Observe that $\pi \oplus \sigma$ avoids $\begin{smallmatrix} \blacksquare & \blacksquare \\ \bullet & \blacksquare \\ \blacksquare & \bullet \end{smallmatrix}$ if and only if both π and σ avoid it. This is the case for instance for $314265 = 3142 \oplus 21$, which corresponds to the above modified ascent sequence $(0, 2, 0, 1, 3, 3) = (0, 2, 0, 1) \oplus (0, 0)$.

We also recall the definitions of $s(\pi)$ and $b(\pi)$. The number of active sites of π is $s(\pi)$. Label these active sites with 0, 1, 2, etc. Then $b(\pi)$ is the label immediately to the left of the maximal entry of π .

The number of minimal (resp. maximal) elements of a poset P is denoted $\min(P)$ (resp. $\max(P)$). The ordinal sum [18, p. 100] of two posets P and Q is the poset $P \oplus Q$ on the union $P \cup Q$ such that $x \leq_{P \oplus Q} y$ if $x \leq_P y$, or $x \leq_Q y$, or $x \in P$ and $y \in Q$. The definition applies to labeled or unlabeled posets. Let us say that P has k components if it is the ordinal sum of k , but not $k + 1$, non-empty posets. Observe that $P \oplus Q$ is $(\mathbf{2} + \mathbf{2})$ -free if and only if both P and Q are $(\mathbf{2} + \mathbf{2})$ -free. For instance, corresponding to the modified ascent sequence $(0, 2, 0, 1, 3, 3) = (0, 2, 0, 1) \oplus (0, 0)$, above, we have

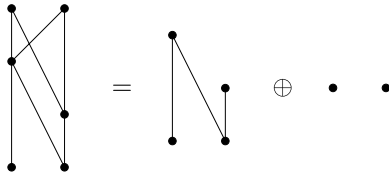

For a $(\mathbf{2} + \mathbf{2})$ -free poset P , a sequence x and a permutation $\pi \in \mathcal{R}$, we define the following polynomials in the indeterminate q :

$$\lambda(P, q) = \sum_{v \in P} q^{\ell(v)}, \quad \chi(x, q) = \sum_{i=1}^{|x|} q^{x_i}, \quad \delta(\pi, q) = \sum_{i=0}^{s(\pi)} d_i q^i,$$

where d_i is the number of entries of π between the active site labeled i and the active site labeled $i + 1$. Note also that an alternative way of writing the polynomial $\lambda(P, q)$ is $\sum_{i=0}^{\ell(P)} |L_i(P)| q^i$. Similarly, define the polynomials

$$\bar{\lambda}(P, q) = \sum_{v \in P_{\max}} q^{\ell(v)}, \quad \bar{\chi}(x, q) = \sum_{x_i \text{ rl-max}} q^{x_i}, \quad \bar{\delta}(\pi, q) = \sum_{i=0}^{s(\pi)} \bar{d}_i q^i,$$

where P_{\max} is the set of maximal elements of P , the sum defining $\bar{\chi}(x, q)$ is restricted to right-to-left maxima of x , and \bar{d}_i is the number of right-to-left maxima of π between the active site labeled i and the active site labeled $i + 1$.

Theorem 12. Given an ascent sequence $x = (x_1, \dots, x_n)$ with modified ascent sequence \widehat{x} , let P and π be the poset and permutation corresponding to x under the bijections described in Sections 2 and 3. Then

$$\begin{aligned} \min(P) &= \text{zeros}(x) = \text{lmin}(\pi); \\ \ell^*(P) &= \text{last}(x) = b(\pi); \\ \ell(P) &= \text{asc}(x) = \text{asc}(\pi^{-1}); \\ \max(P) &= \text{rmax}(\widehat{x}) = \text{rmax}(\pi); \\ \text{comp}(P) &= \text{comp}(\widehat{x}) = \text{comp}(\pi); \\ \lambda(P, q) &= \chi(\widehat{x}, q) = \delta(\pi, q); \\ \bar{\lambda}(P, q) &= \bar{\chi}(\widehat{x}, q) = \bar{\delta}(\pi, q). \end{aligned}$$

Example 5. Let P be the poset from Example 3 and let x and π be the corresponding ascent sequence and permutation:

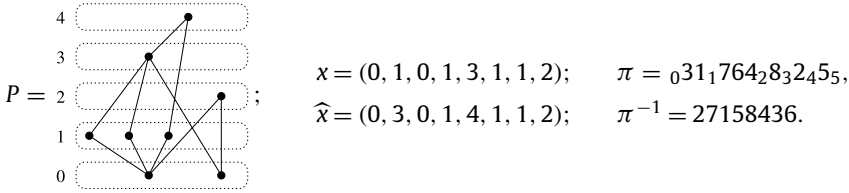

Theorem 12 holds, with $\min(P) = 2$, $\ell^*(P) = 2$, $\ell(P) = 4$, $\max(P) = 2$, $\text{comp}(P) = 1$, $\lambda(P, q) = q^4 + q^3 + q^2 + 3q + 2$, and $\bar{\lambda}(P, q) = q^4 + q^2$.

Proof of Theorem 12. The polynomial identity $\lambda(P, q) = \chi(\widehat{x}, q) = \delta(\pi, q)$ is a consequence of Lemma 7 for the first part, and of Corollary 9 for the second part. Setting $q = 0$ in $\lambda(P, q) = \chi(\widehat{x}, q)$ gives $\min(P) = \text{zeros}(x)$ (note that $\text{zeros}(x) = \text{zeros}(\widehat{x})$). Setting $q = 0$ in the identity $\chi(\widehat{x}, q) = \delta(\pi, q)$ shows that $\text{zeros}(x)$ is the number of entries of π between the first two active sites. Let us prove that these are the entries $\pi_1, \pi_2, \dots, \pi_k$, where k is the largest integer such that $\pi_1 > \pi_2 > \dots > \pi_k$. Note that this means that $\text{lmin}(\pi) = k$. For $1 \leq i < k$, the entry π_i is followed by an inactive site, because $\pi_i - 1$ appears to the right of π_i . Assume $\pi_k > 1$. Then $\pi_k - 1$ appears to the right of π_k , but $\pi_{k+1} > \pi_k$, so that $\pi_k \pi_{k+1} (\pi_k - 1)$ is an occurrence of the forbidden pattern, a contradiction. So $\pi_k = 1$, the site following π_k is active, and the result is proved.

The result dealing with $\text{last}(x)$ has already been proved, when we established that Λ and Ψ were indeed bijections. See (2) and (5). The same holds for the connection between $\text{asc}(x)$ and $\ell(P)$ (see (5) again). We also know that $\text{asc}(x) = s(\pi) - 2$, but we wish to relate this number to $\text{asc}(\pi^{-1})$.

The next identities will be proved by induction on n . These are easy to check when $n = 1$, so we take $n \geq 2$. Denote $i = x_n$, $(Q, i) = \psi(P)$, and let τ be obtained by deleting the entry n from π . Let $x' = (x_1, \dots, x_{n-1}) = \Lambda(\tau) = \Psi(Q)$.

Let us start with the connection between $\text{asc}(x)$ and $\text{asc}(\pi^{-1})$. The number of ascents increases (by one) when going from τ^{-1} to π^{-1} if and only if n is inserted, in τ , to the right of $n - 1$: as shown in the proof of Theorem 1, this means that $\text{asc}(x) = 1 + \text{asc}(x')$ (Case 2 of the proof).

The identity that involves $\max(P)$ is just the case $q = 1$ of the identity that involves the polynomial $\bar{\lambda}(P, q)$, which we now prove. Let us now study how the polynomials $\bar{\lambda}(\cdot, q)$, $\bar{\chi}(\cdot, q)$ and $\bar{\delta}(\cdot, q)$ evolve as the size of the poset/sequence/permutation increases. For posets,

$$\bar{\lambda}(P, q) = \begin{cases} \bar{\lambda}(Q, q) + q^i & \text{if } i \leq \ell^*(Q), \\ q^i + \sum_{j=i}^{\ell(Q)} |\bar{L}_j(Q)| q^{j+1} & \text{if } i > \ell^*(Q), \end{cases}$$

where $\bar{L}_j(Q)$ is the set of maximal elements of Q at level j . Similar relations hold for $\bar{\chi}(\widehat{x}, q)$ and $\bar{\delta}(\pi, q)$. Denoting the modified ascent sequence of x' by $\widehat{x}' = (\widehat{x}'_1, \dots, \widehat{x}'_{n-1})$, we have

$$\bar{\chi}(\widehat{x}, q) = \begin{cases} \bar{\chi}(\widehat{x}', q) + q^i & \text{if } i \leq x_{n-1}, \\ q^i + \sum_{r1 - \max \widehat{x}'_j \geq i} q^{\widehat{x}'_j + 1} & \text{if } i > x_{n-1}, \end{cases}$$

$$\bar{\delta}(\pi, q) = \begin{cases} \bar{\delta}(\tau, q) + q^i & \text{if } i \leq b(\tau), \\ q^i + \sum_{j \geq i} \bar{d}_j q^{j+1} & \text{if } i > b(\tau), \end{cases}$$

and the statement $\bar{\lambda}(P, q) = \bar{\chi}(\widehat{x}, q) = \bar{\delta}(\pi, q)$ follows by induction.

We shall finally prove that $\text{comp}(P) = \text{comp}(\widehat{x}) = \text{comp}(\pi)$. First, observe that it suffices to prove that

$$\begin{aligned} \widehat{x} &= \widehat{y} \oplus \widehat{z} \quad \text{with } |y| = \ell \text{ and } |z| = m \\ \Leftrightarrow \pi &= \sigma \oplus \tau \quad \text{with } |\sigma| = \ell \text{ and } |\tau| = m \\ \Leftrightarrow P &= P_y \oplus P_z \quad \text{with } |P_y| = \ell \text{ and } |P_z| = m, \end{aligned}$$

and that σ and P_y (resp. τ and P_z) are respectively the permutation and the poset associated with the ascent sequence y (resp. z). It then follows by induction on the number of components, not only that \widehat{x} , π and P have the same number of components, but also that the sizes of the components are the same.

From Corollary 9, it is easily seen that $\pi = \sigma \oplus \tau$ if and only if $\widehat{x} = \widehat{y} \oplus \widehat{z}$, with $\Lambda(\sigma) = y$ and $\Lambda(\tau) = z$. Assume this holds. Let us write $\ell = |y|$ and $m = |z|$. Let P_y and P_z be the posets corresponding to y and z , respectively. Let us prove that the *canonically labeled* versions of P , P_y and P_z satisfy $P = P_y \oplus P_z$. Clearly, the ℓ first steps of the recursive construction of P (starting from the ascent sequence x) give the (labeled) poset P_y , which satisfies $\ell(P_y) = \max(\widehat{y})$ by Lemma 7. Then comes the letter $x_{\ell+1}$. As $\widehat{x}_{\ell+1} = 1 + \max\{\widehat{x}_j : j \leq \ell\}$, the element $\ell + 1$ ends up, in the final poset P , at a higher level than the elements $1, 2, \dots, \ell$. This implies that the element $\ell + 1$ is added using the operation Add2, and hence covers all maximal elements of P_y . Consequently, the set of predecessors of $\ell + 1$ is P_y , and the poset obtained at this stage is $P_y \oplus \{\ell + 1\}$. One then proceeds by induction on the size of z . We do not give the details. One checks inductively that the relative order of the elements labeled $\ell + 1$ to $n = \ell + m$ in P coincides with their order in P_z , and that every element of P_y is smaller than every element of P_z .

Conversely, assume $P = P_y \oplus P_z$, with $\ell = |P_y|$, $m = |P_z|$ and $\ell + m = n$. We will prove that in the canonical labelling of P , the largest m letters are those of P_z . Again, this follows from an induction on m . As usual, we write $(Q, i) = \psi(P)$. If $m = 1$, then n is the unique maximal element of P , and $Q = P_y$. Otherwise, the element n is in P_z (as P_y contains no maximal element), and one has to check that $Q = P_y \oplus P'_z$ where P'_z is obtained by applying the removal procedure to P_z . We do not give all the details. The key point is that, when Rem3 is used, the set $\mathcal{N} = D_{i+1} \setminus D_i$ of elements that become maximal in Q does not contain any element of P_y . Indeed, every element of P_y is smaller than every element of P_z , so that it belongs to D_i . Once it is proved that the m largest elements of P are those of P_z , one applies Proposition 8 to conclude that the corresponding permutation π reads $\sigma \oplus \tau$, where σ (resp. τ) corresponds to P_y (resp. P_z). \square

6. The number of (2 + 2)-free posets

The aim of this section is to obtain a closed form expression for the generating function $P(t)$ of unlabeled (2 + 2)-free posets:

$$\begin{aligned} P(t) &= \sum_{n \geq 0} p_n t^n \\ &= 1 + t + 2t^2 + 5t^3 + 15t^4 + 53t^5 + 217t^6 + 1014t^7 + 5335t^8 + O(t^9), \end{aligned}$$

where p_n is the number of (2 + 2)-free posets of cardinality n . The sequence $(p_n)_{n \geq 0}$ is Sequence A022493 in the OEIS [15].

Theorem 13. *The generating function of unlabeled (2 + 2)-free posets is*

$$P(t) = \sum_{n \geq 0} \prod_{i=1}^n (1 - (1 - t)^i).$$

Of course, the series $P(t)$ also counts permutations of \mathcal{R} , or ascent sequences, by length. To our knowledge, this result is new. El-Zahar [8] and Khamis [13] used a recursive description of

(2+2)-free posets, different from that of Section 3, to derive a pair of functional equations that define the series $P(t)$. However, they did not solve these equations. Haxell, McDonald and Thomasson [12] provided an algorithm, based on a complicated recurrence relation, to produce the first numbers p_n . However, the above series has already appeared in the literature: it was proved by Zagier [23] to count certain involutions introduced by Stoimenow [20]. (The connection between these involutions and (2+2)-free posets is the topic of the next section.) Moreover, Zagier derived a number of interesting properties of the series $P(t)$. In particular, he gave the following asymptotic estimate:

$$\frac{p_n}{n!} \sim \kappa \left(\frac{6}{\pi^2}\right)^n \sqrt{n}, \quad \text{where } \kappa = \frac{12\sqrt{3}}{\pi^{5/2}} e^{\pi^2/12}.$$

Note that since the growth constant $6/\pi^2$ is transcendental it follows that the generating function is not D-finite [19,22]. Zagier also proved that the series $P(t)$ satisfies the following remarkable formula:

$$P(1 - e^{-24x}) = e^x \sum_{n \geq 0} \frac{T_n}{n!} x^n,$$

where

$$\sum_{n \geq 0} \frac{T_n}{(2n + 1)!} x^{2n+1} = \frac{\sin 2x}{2 \cos 3x}.$$

Our proof of Theorem 13 exploits the recursive structure of ascent sequences. This structure translates into a functional equation for the generating function of these sequences, which is solved by the so-called kernel method. This gives a closed form expression of a bivariate generating function, which counts ascent sequences by their length and ascent number. However, one still needs to transform this expression to obtain the above expression for the length generating function.

6.1. The functional equation

Let $F(t; u, v) \equiv F(u, v)$ be the generating function of ascent sequences, counted by length (variable t), number of ascents (variable u) and last entry (variable v). This is a formal power series in t with coefficients in $\mathbb{Q}[u, v]$. The first few terms of $F(t; u, v)$ are

$$F(t; u, v) = 1 + t + (1 + uv)t^2 + (1 + 2uv + u + u^2v^2)t^3 + O(t^4).$$

Let $G(t; u, v) = F(t; u, v) - 1 \equiv G(u, v)$ count non-empty ascent sequences. We write

$$G(t; u, v) = \sum_{a, \ell \geq 0} G_{a, \ell}(t) u^a v^\ell,$$

so that $G_{a, \ell}(t)$ is the length generating function of sequences having a ascents and ending with the value ℓ .

Lemma 14. *The generating function $G(t; u, v)$ satisfies*

$$(v - 1 - tv(1 - u))G(u, v) = t(v - 1) - tG(u, 1) + tuv^2G(uv, 1).$$

Equivalently, $F(t; u, v) = 1 + G(t; u, v)$ satisfies

$$(v - 1 - tv(1 - u))F(u, v) = (v - 1)(1 - tuv) - tF(u, 1) + tuv^2F(uv, 1).$$

Proof. Let $x' = (x_1, \dots, x_{n-1})$ be a non-empty ascent sequence with a ascents, ending with the value $x_{n-1} = \ell$. Then $x = (x_1, \dots, x_{n-1}, i)$ is an ascent sequence if and only if $i \in [0, a + 1]$. Moreover, the sequence x has a ascents if $i \leq \ell$, and $a + 1$ ascents otherwise. Given that (0) is the only ascent sequence of length 1, this gives:

$$\begin{aligned} G(u, v) &= t + t \sum_{a, \ell \geq 0} G_{a, \ell}(t) \left(\sum_{i=0}^{\ell} u^a v^i + \sum_{i=\ell+1}^{a+1} u^{a+1} v^i \right) \\ &= t + t \sum_{a, \ell \geq 0} G_{a, \ell}(t) u^a \left(\frac{v^{\ell+1} - 1}{v - 1} + u \frac{v^{a+2} - v^{\ell+1}}{v - 1} \right) \\ &= t + t \frac{vG(u, v) - G(u, 1)}{v - 1} + tuv \frac{vG(uv, 1) - G(u, v)}{v - 1}. \end{aligned}$$

The result follows. \square

Remark. The variables u and v are needed to transform our recursive description of ascent sequences into a functional equation, and are thus *catalytic*, in the sense of [24]. Setting $v = 1$ in the equation gives a tautology. Setting $u = 1$ gives a relation between $G(1, v)$, $G(1, 1)$ and $G(v, 1)$ which does not suffice to characterize these series.

6.2. The kernel method

Consider the functional equation satisfied by $F(t; u, v)$ given by Lemma 14. The coefficient of $F(u, v)$, called the *kernel*, vanishes when $v = V(u)$, with $V(u) = 1/(1 - t + tu)$. Recall that $F(t; u, v)$ is a series in t with coefficients in $\mathbb{Q}[u, v]$. Hence $F(u, V(u))$ is a well-defined series in t with coefficients in $\mathbb{Q}[u]$. Replacing v by $V(u)$ in the functional equation cancels the left-hand side, and results in:

$$F(u, 1) = \frac{(1 - u)(1 - t)}{(1 - t + tu)^2} + \frac{u}{(1 - t + tu)^2} F\left(\frac{u}{1 - t + tu}, 1\right).$$

Iterating this equation gives

$$\begin{aligned} F(u, 1) &= \frac{(1 - u)(1 - t)}{(1 - t + tu)^2} + \frac{u(1 - t)^2(1 - u)}{(1 - t + tu)(1 - 2t + 2tu + t^2 - t^2u)^2} \\ &\quad + \frac{u^2}{(1 - t + tu)(1 - 2t + 2tu + t^2 - t^2u)^2} F\left(\frac{u}{1 - 2t + 2tu + t^2 - t^2u}, 1\right) \\ &= \sum_{k=1}^n \frac{(1 - u)u^{k-1}(1 - t)^k}{(u - (u - 1)(1 - t)^k) \prod_{i=1}^k (u - (u - 1)(1 - t)^i)} \\ &\quad + \frac{u^n}{(u - (u - 1)(1 - t)^n) \prod_{i=1}^n (u - (u - 1)(1 - t)^i)} F\left(\frac{u}{u - (u - 1)(1 - t)^n}, 1\right). \end{aligned}$$

Letting $n \rightarrow \infty$, we obtain a first expression of $F(t; u, 1)$, as a formal series in u with rational coefficients in t .

Proposition 15. *The series $F(t; u, 1)$ counting ascent sequences by their length and ascent number, seen as a series in u , has rational coefficients in t , and satisfies*

$$F(t; u, 1) = \sum_{k \geq 1} \frac{(1 - u)u^{k-1}(1 - t)^k}{(u - (u - 1)(1 - t)^k) \prod_{i=1}^k (u - (u - 1)(1 - t)^i)}.$$

Alas, the above expression is only convergent as a series in u . In particular, if we set $u = 1$, the result seems to be zero (because of the factor $(1 - u)$). If we ignore this factor, what remains reads

$$\sum_{k \geq 1} (1 - t)^k,$$

which is not a convergent series in the formal variable t . We will now work out another series expression of $F(t; u, 1)$, which converges as a series in t with coefficients in $\mathbb{Q}[u]$. In this expression we can set $u = 1$, and this will give Theorem 13.

6.3. Transforming the solution

Our first lemma tells us that certain series, which look like the one in Proposition 15, are actually polynomials in u and t .

Lemma 16. *Let $m \geq 1$ be an integer. Let $S(t; u)$ be the following series in u , with rational coefficients in t :*

$$S(t; u) = \sum_{k \geq 1} \frac{(u - 1)^m u^{k-1} (1 - t)^{mk}}{\prod_{i=1}^k (u - (u - 1)(1 - t)^i)}.$$

Then $S(t; u)$ is actually a polynomial in u and t :

$$S(t; u) = - \sum_{j=0}^{m-1} (u - 1)^j u^{m-1-j} (1 - t)^j \prod_{i=j+1}^{m-1} (1 - (1 - t)^i).$$

Proof. Consider the following equation in $\Phi(t; u) \equiv \Phi(u)$:

$$\Phi(u) = \frac{(u - 1)^m (1 - t)^m}{1 - t + tu} + u(1 - t + tu)^{m-2} \Phi\left(\frac{u}{1 - t + tu}\right).$$

By iterating it, we see that it has a unique solution in the space of series in u with rational coefficients in t , and that this solution is the first expression of $S(t; u)$ given above. Moreover, by writing the equation as follows:

$$(1 - t + tu)\Phi(u) = (u - 1)^m (1 - t)^m + u(1 - t + tu)^{m-1} \Phi\left(\frac{u}{1 - t + tu}\right),$$

one checks easily that the second expression of $S(t; u)$ (a polynomial in t and u) is also a solution. Since a polynomial in t and u is (also) a series in u with rational coefficients in t , the identity is established. \square

From the above lemma, we are going to derive another expression of the series $F(t; u, 1)$, in which the substitution $u = 1$ raises no difficulty.

Theorem 17. *Let $n \geq 0$, and consider the following polynomial in t and u :*

$$F_n(t; u) = \sum_{\ell=0}^n (u - 1)^{n-\ell} u^\ell \sum_{m=\ell}^n (-1)^{n-m} \binom{n}{m} (1 - t)^{m-\ell} \prod_{i=m-\ell+1}^m (1 - (1 - t)^i).$$

Then $F_n(t; u)$ is a multiple of t^n . Moreover, the generating function of ascent sequences, counted by the length and the ascent number, is

$$F(t; u, 1) = \sum_{n \geq 0} F_n(t; u).$$

When $u = 1$,

$$F_n(t; 1) = \prod_{i=1}^n (1 - (1 - t)^i),$$

and Theorem 13 follows.

Proof. We return to the expression of $F(t; u, 1)$ given in Proposition 15. The expansion

$$\frac{1}{u - (u - 1)(1 - t^k)} = \frac{1}{1 - (u - 1)((1 - t)^k - 1)} = \sum_{n \geq 0} (u - 1)^n ((1 - t)^k - 1)^n$$

is valid in the space of series in t with polynomial coefficients in u , as $(1 - t)^k - 1 = O(t)$. It holds as well in the larger space of formal power series in t and u . Moreover, the n th term is $O(t^n)$. Hence, in the space of series in t and u ,

$$F(t; u, 1) = \sum_{k \geq 1} \frac{(1 - u) u^{k-1} (1 - t)^k}{\prod_{i=1}^k (u - (u - 1)(1 - t)^i)} \sum_{n \geq 0} (u - 1)^n ((1 - t)^k - 1)^n = \sum_{n \geq 0} F_n(t; u)$$

where

$$\begin{aligned} F_n(t; u) &= - \sum_{k \geq 1} \frac{(u - 1)^{n+1} u^{k-1} (1 - t)^k}{\prod_{i=1}^k (u - (u - 1)(1 - t)^i)} ((1 - t)^k - 1)^n \\ &= - \sum_{k \geq 1} \frac{(u - 1)^{n+1} u^{k-1} (1 - t)^k}{\prod_{i=1}^k (u - (u - 1)(1 - t)^i)} \sum_{m=0}^n \binom{n}{m} (1 - t)^{km} (-1)^{n-m} \\ &= - \sum_{m=0}^n \binom{n}{m} (-1)^{n-m} (u - 1)^{n-m} \sum_{k \geq 1} \frac{(u - 1)^{m+1} u^{k-1} (1 - t)^{k(m+1)}}{\prod_{i=1}^k (u - (u - 1)(1 - t)^i)}. \end{aligned}$$

It remains to apply Lemma 16, with m replaced by $m + 1$:

$$F_n(t; u) = \sum_{m=0}^n (-1)^{n-m} \binom{n}{m} (u - 1)^{n-m} \sum_{j=0}^m (u - 1)^j u^{m-j} (1 - t)^j \prod_{i=j+1}^m (1 - (1 - t)^i).$$

The expected expression of $F_n(t; u)$ follows, upon writing $j = m - \ell$. \square

7. Involutions with no neighbour nesting

As discussed above, the series of Theorem 13 is known to count certain involutions on $2n$ points, called *regular linearized chord diagrams* (RLCD) by Stoimenow [20]. This result was proved by Zagier [23], following Stoimenow’s paper. In this section, we give a new proof of Zagier’s result, by constructing a bijection between RLCDs on $2n$ points and unlabeled $(\mathbf{2} + \mathbf{2})$ -free posets of size n .

Let \mathcal{I}_{2n} be the collection of involutions π in \mathcal{S}_{2n} that have no fixed points and for which every descent crosses the main diagonal in its dot diagram. Equivalently, if $\pi_i > \pi_{i+1}$ then $\pi_i > i \geq \pi_{i+1}$. An alternative description can be given in terms of the *chord diagram* of π , which is obtained by joining the points i and π_i by a chord (Fig. 2, top left). Indeed, $\pi \in \mathcal{I}_{2n}$ if and only if, for any i , the chords attached to i and $i + 1$ are not *nested*, in the terminology used recently for partitions and involutions (or matchings) [6,14]. That is, the configurations shown on the left of the rules of Fig. 3 are forbidden (but a chord linking i to $i + 1$ is allowed). Such involutions were called *regular linearized chord diagrams* by Stoimenow. We prefer to say that they have *no neighbour nesting*.

Recall that a poset P is $(\mathbf{2} + \mathbf{2})$ -free if and only if it is an *interval order* [10]. This means that there exists a collection of intervals on the real line whose relative order is P , under the relation:

$$[a_1, a_2] < [a_3, a_4] \iff a_2 < a_3. \tag{6}$$

Let π be a fixed point free involution with transpositions $\{(\alpha_i, \beta_i)\}_{i=1}^n$ where $\alpha_i < \beta_i$ for all i . Define $\Omega(\pi)$ to be the interval order (or equivalently, $(\mathbf{2} + \mathbf{2})$ -free poset) associated with the collection of intervals $\{[\alpha_i, \beta_i]\}_{i=1}^n$. The transformation Ω has a symmetry property that will be important: the poset associated with the mirror of π (obtained by reflecting the chord diagram of π across a vertical line) is the dual of $\Omega(\pi)$.

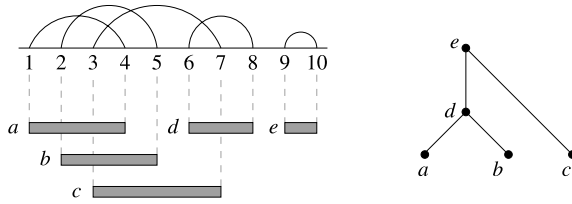

Fig. 2. The involution $\pi = 45712836109 \in \mathcal{I}_{10}$, the corresponding collection of intervals and the associated $(2+2)$ -free poset.

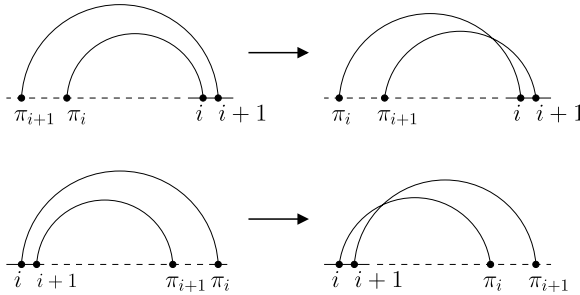

Fig. 3. Two operations on chord diagrams.

Example 6. Consider $\pi = 45712836109 \in \mathcal{I}_{10}$. The transpositions of π are shown in the chord diagram of Fig. 2. Beneath the chord diagram is the collection of intervals that corresponds to π , and the $(2+2)$ -free poset $\Omega(\pi)$ is shown on the right-hand side. We have added labels to highlight the correspondence between intervals and poset elements.

Theorem 18. The map Ω , restricted to involutions with no neighbour nesting, induces a bijection between involutions of \mathcal{I}_{2n} and $(2+2)$ -free posets on n elements.

Proof. Let us first prove that the restriction of Ω is a surjection. That is, for every poset $P \in \mathcal{P}_n$, one can find an involution $\pi \in \mathcal{I}_{2n}$ such that $\Omega(\pi) = P$. Let $P \in \mathcal{P}_n$. As P is an interval order, there exists a collection of n intervals on the real line whose relative order is P , under the order relation (6). We can assume that the (right and left) endpoints of these n intervals are $2n$ distinct points. Indeed, if some point x occurs k times as an endpoint, then the intervals ending at x are incomparable, and one can replace x by k distinct points and obtain a new collection of intervals whose order is still P , as shown below.



Note that in this figure, intervals are represented by chords rather than segments for the sake of clarity. In particular, an interval reduced to one point is represented by a loop.

Clearly, we can then assume that the $2n$ distinct endpoints of our n intervals are exactly $1, 2, \dots, 2n$. These intervals thus form a chord diagram, and there exists a fixed point free involution $\pi \in \mathcal{S}_{2n}$ such that $\Omega(\pi) = P$. However, π may have neighbour nestings. Transform recursively every such nesting as shown in Fig. 3. The corresponding poset does not change with these transformations, while the number of crossings in the chord diagram increases. Hence the sequence of transformations must stop, and when it stops we have obtained an involution π' with no neighbour nesting such that $\Omega(\pi') = P$. An example is shown in Fig. 4, where we have indicated by a white dot which nesting is transformed.

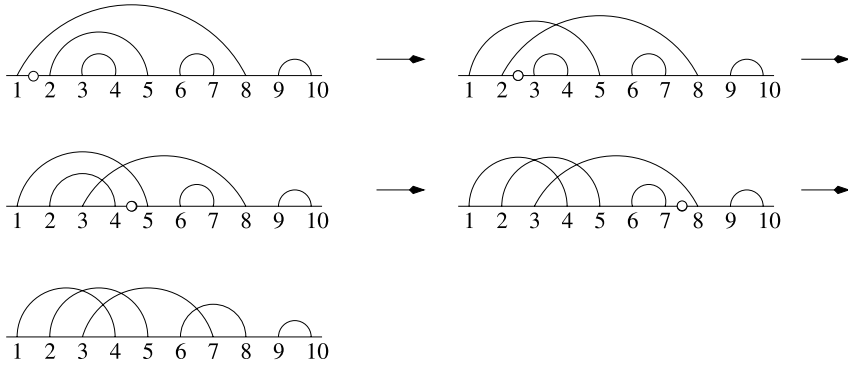
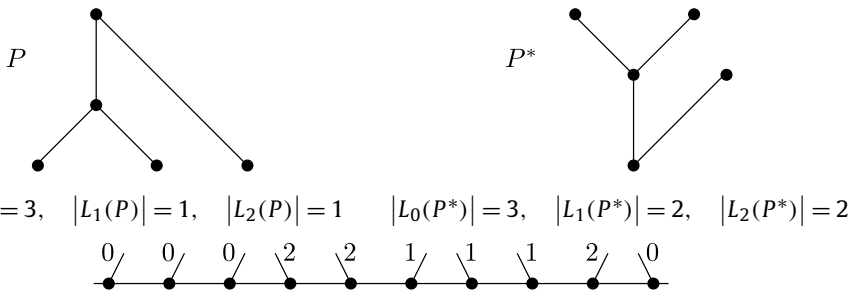

Fig. 4. Deleting neighbour nestings from an involution.

Let us now prove that Ω , restricted to \mathcal{I}_{2n} , is injective. Assume $\pi \in \mathcal{I}_{2n}$ and $\Omega(\pi) = P$. We will prove that one can reconstruct the chord diagram of π from P .

We associate with π a word $u = u_1u_2 \cdots u_{2n}$ over the alphabet $\{o, c\}$ as follows: $u_i = o$ (resp. c) if there is an opening (resp. closing) chord at i . That is, if $\pi_i > i$ (resp. $\pi_i < i$). We define an *opening run* to be a maximal factor of u containing only the letter o . We define similarly closing runs. For instance, the involution in Fig. 2 has 3 opening runs (and consequently 3 closing runs).

The order $P = \Omega(\pi)$ can be seen as an order on the chords of π : given a chord $a = (i, j)$, with $i < j$, the chords that are smaller than a (the *predecessors* of a) are those that close before i , and the chords that are larger than a are those that open after j . From this observation, it follows easily, by induction on i , that the *level* of a in P (as defined in Section 3) is the number of closing runs found before i in u . Let $k = \ell(P)$ be the highest level of an element of P , and for $0 \leq i \leq k$, denote by m_i the number of elements at level i in P . Then the preceding discussion implies that the word u associated with π is of the form $o^{m_0}c^{n_k}o^{m_1}c^{n_{k-1}} \dots o^{m_k}c^{n_0}$ where $n_i > 0$ for all i . But by symmetry, n_i must be the number of elements at level i in P^* (and moreover, $\ell(P) = \ell(P^*)$). Thus the word u can be reconstructed from P and its dual. We represent u by a sequence of $2n$ half-chords, some opening, some closing. For instance, we show below the sequence of half-chords obtained from the poset P of Fig. 2 and its dual P^* . It is convenient to assign with each opening (resp. closing) half-chord a label, equal to the level of the corresponding element of P (resp. P^*).



It remains to see that the matching between opening and closing half-chords that characterizes π is forced by P . We will prove this recursively, by matching opening chords run by run, from left to right. That is, we match the m_0 opening chords labelled 0, then the m_1 opening chords labelled 1, and so on. Assume we have matched the first $m_0 + m_1 + \dots + m_{j-1}$ opening chords. For $0 \leq j \leq k$, let $m_{i,j}$ be the number of elements of P that have level i in P and level j in P^* . This is the number of chords of π with opening label i and closing label j . Of course, $m_{i,0} + \dots + m_{i,k} = m_i$.

Observe the following property:

(★) An involution π avoids neighbour nestings if and only if, for every opening run found at positions $i, i + 1, \dots, i + \ell$, one has $\pi_i < \pi_{i+1} < \dots < \pi_{i+\ell}$, and symmetrically, for every closing run found at positions $i - \ell, \dots, i - 1, i$, one has $\pi_{i-\ell} < \dots < \pi_{i-1} < \pi_i$.

This property implies that the $m_{i,k}$ first (i.e., leftmost) opening chords labelled i must be matched with closing chords labelled k , the $m_{i,k-1}$ next opening chords labelled i must be matched with closing chords labelled $k - 1$, and so on. The second part of property (★) then forces the choice of the $m_{i,j}$ closing chords that will be matched with opening chords labelled i : they are the leftmost unmatched closing chords labelled j . The matching of half-arches is thus forced, and π can be completely reconstructed from P . Hence the restriction of Ω to \mathcal{I}_{2n} is injective.

Let us illustrate the matching procedure by completing our running example. For the above poset P , we find $m_{0,2} = 2, m_{0,1} = 1, m_{0,0} = 0$, which allows us to match the chords of the first opening run (equivalently, the opening chords labelled 0):

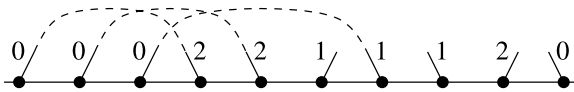

Then, $m_{1,2} = 0, m_{1,1} = 1, m_{1,0} = 0$, which forces the matching of the (unique) opening chord labelled 1:

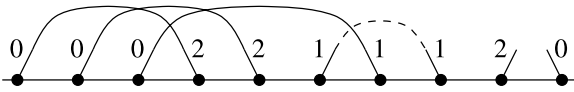

Finally, $m_{2,2} = 0, m_{2,1} = 0, m_{2,0} = 1$, and we recover the involution with no neighbour nesting shown in Fig. 2:

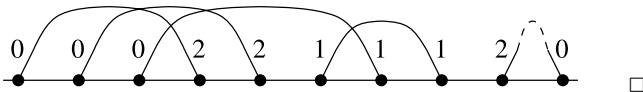

Remarks.

1. It follows from the proof of Theorem 18 that, given any collection of intervals with distinct end-points whose relative order is P , the transformations in Fig. 3, applied in any order, will yield ultimately the chord diagram of the involution $\Omega^{-1}(P)$. Note that these transformations boil down to conjugating a fixed point free involution by the elementary transposition $(i, i + 1)$.
2. We have worked out the recursive description of involutions of \mathcal{I}_{2n} that corresponds, via the transformation Ω , to the recursive construction of $(\mathbf{2} + \mathbf{2})$ -free posets described in Section 3, but it is rather involved [7].
3. The correspondence Ω allows one to read from an involution $\pi \in \mathcal{I}_{2n}$ the statistics defined in Section 5 for the poset $P = \Omega(\pi)$. For instance, the number of minimal elements in P is the length of the first opening run of π . Symmetrically, the number of maximal elements of P is the length of the last closing run of π . We have already discussed how the distribution of levels of the elements of P can be read from π . Finally, there is a natural analogue on involutions for the number of components of a poset.

8. Final questions and remarks

Question 1. Is there a simple graphical construction on the dot diagram of a permutation in \mathcal{R}_n that gives bijectively an unlabeled $(\mathbf{2} + \mathbf{2})$ -free poset on n elements?

A simple idea would be to view the dots of the diagram as a poset under the standard product order on \mathbb{N}^2 , as is done in [5]. For $n \leq 4$ the posets associated with permutations of \mathcal{R}_n are exactly the

unlabeled $(\mathbf{2} + \mathbf{2})$ -free posets of size n . However, for $n = 5$ the poset corresponding to the permutation $\pi = 41523 \in \mathcal{R}_5$ contains an induced copy of $\mathbf{2} + \mathbf{2}$. This is illustrated in the diagram below.

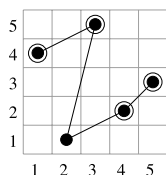

Question 2. Ascent sequences are special inversion tables. Turn these inversion tables into permutations in the two standard ways (see [18, p. 20-21]). Is there a simple characterization of those sets of permutations?

Question 3. A simple involution acts on the set of $(\mathbf{2} + \mathbf{2})$ -free posets: duality, or order-reversion. In terms of chord diagrams, this corresponds to taking the mirror image of a diagram. What is the corresponding transformation on permutations of \mathcal{R} ? For instance, the permutation associated with the poset P of Example 3 is 31746825, while the permutation associated with the dual poset P^* is 41726583.

Acknowledgment

Thanks to Henning Úlfarsson for pointing out that bivincular permutations form a quasigroup, rather than a group as we incorrectly claimed in an earlier draft.

References

- [1] M.H. Albert, M.D. Atkinson, R. Brignall, Permutation classes of polynomial growth, *Ann. Comb.* 11 (2007) 249–264.
- [2] M.D. Atkinson, T. Stitt, Restricted permutations and the wreath product, *Discrete Math.* 259 (2002) 19–36.
- [3] E. Babson, E. Steingrímsson, Generalized permutation patterns and a classification of the Mahonian statistics, *Sém. Lothar. Combin.* 44 (2000), Art. B44b, 18 pp.
- [4] K.P. Bogart, An obvious proof of Fishburn's interval order theorem, *Discrete Math.* 118 (1993) 239–242.
- [5] M. Bousquet-Mélou, S. Butler, Forest-like permutations, *Ann. Comb.* 11 (2007) 335–354.
- [6] W.Y.C. Chen, E.Y. Deng, R.R. Du, R.P. Stanley, C.H. Yan, Crossings and nestings of matchings and partitions, *Trans. Amer. Math. Soc.* 359 (2007) 1555–1575.
- [7] A. Claesson, M. Dukes, S. Kitaev, A direct encoding of Stoimenow's matchings as ascent sequences, arXiv:0910.1619.
- [8] M.H. El-Zahar, Enumeration of ordered sets, in: I. Rival (Ed.), *Algorithms and Order*, Kluwer Academic Publishers, Dordrecht, 1989, pp. 327–352.
- [9] P.C. Fishburn, *Interval Graphs and Interval Orders*, Wiley, New York, 1985.
- [10] P.C. Fishburn, Intransitive indifference in preference theory: A survey, *Oper. Res.* 18 (1970) 207–208.
- [11] P.C. Fishburn, Intransitive indifference with unequal indifference intervals, *J. Math. Psych.* 7 (1970) 144–149.
- [12] P.E. Haxell, J.J. McDonald, S.K. Thomasson, Counting interval orders, *Order* 4 (1987) 269–272.
- [13] S.M. Khamis, Height counting of unlabeled interval and N -free posets, *Discrete Math.* 275 (2004) 165–175.
- [14] C. Krattenthaler, Growth diagrams, and increasing and decreasing chains in fillings of Ferrers shapes, *Adv. in Appl. Math.* 37 (2006) 404–431.
- [15] S. Plouffe, N.J.A. Sloane, *The Encyclopedia of Integer Sequences*, Academic Press, Inc., San Diego, 1995, electronic version available at <http://www.research.att.com/~njas/sequences/>.
- [16] L. Pudwell, Enumeration schemes for pattern-avoiding words and permutations, PhD thesis, Rutgers University, 2008.
- [17] M. Skandera, A characterization of $(3 + 1)$ -free posets, *J. Combin. Theory Ser. A* 93 (2001) 231–241.
- [18] R.P. Stanley, *Enumerative Combinatorics*, vol. 1, Cambridge Stud. Adv. Math., vol. 49, Cambridge University Press, Cambridge, 1997.
- [19] R.P. Stanley, *Enumerative Combinatorics*, vol. 2, Cambridge Stud. Adv. Math., vol. 62, Cambridge University Press, Cambridge, 1999.
- [20] A. Stoimenow, Enumeration of chord diagrams and an upper bound for Vassiliev invariants, *J. Knot Theory Ramifications* 7 (1998) 93–114.
- [21] J. West, Generating trees and the Catalan and Schröder numbers, *Discrete Math.* 146 (1995) 247–262.
- [22] J. Wimp, D. Zeilberger, Resurrecting the asymptotics of linear recurrences, *J. Math. Anal. Appl.* 111 (1985) 162–176.
- [23] D. Zagier, Vassiliev invariants and a strange identity related to the Dedekind eta-function, *Topology* 40 (2001) 945–960.
- [24] D. Zeilberger, The umbral transfer-matrix method: I. Foundations, *J. Combin. Theory Ser. A* 91 (2000) 451–463.