

Available online at www.sciencedirect.com**ScienceDirect**

Procedia Technology 11 (2013) 366 – 373

Procedia
Technology

The 4th International Conference on Electrical Engineering and Informatics (ICEEI 2013)

Coordination of Overcurrent, Directional and Differential Relays for the Protection of Microgrid System

Ahmad Razani Haron*, Azah Mohamed, Hussain Shareef

Department of Electrical, Electronics & System Engineering, Universiti Kebangsaan Malaysia, 43000, Bangi, Selangor, Malaysia

Abstract

Microgrid implementation draws new challenges especially in the coordination of protective devices that are not likely to appear in a traditional distribution network. Variation of fault current levels, bi-directional fault current and changing of microgrid operation modes make protection of the microgrids more difficult. In this work, a systematic procedure for coordination of different protection schemes is presented to secure the operation of a microgrid system. The procedure initially starts with coordination of overcurrent (OC) relays and followed by directional overcurrent (DOC) relays in the system. If the coordination of these two types of relays is unsatisfactory, then differential (DIF) relays are used to replace the OC relay in the faulty section. The proposed method takes into account device selectivity, sensitivity and proper protection function simultaneously. Simulation results show that the proposed coordination method safely protect a microgrid system during both grid-connected and islanded operation modes.

© 2013 The Authors. Published by Elsevier Ltd. Open access under [CC BY-NC-ND license](https://creativecommons.org/licenses/by-nc-nd/4.0/).

Selection and peer-review under responsibility of the Faculty of Information Science & Technology, Universiti Kebangsaan Malaysia.

Keywords: Protection Coordination; Coordination Issues; Overcurrent; Directional; Differential; Microgrid; Grid-connected Mode; Islanded Mode;

1. Introduction

Microgrid operation requires a number of distributed generations (DGs) to be connected to the distribution network. The addition of DG contributes positively and negatively to the distribution system protection. As a

* Corresponding author. Tel.: +6010-9313026; fax: +603-89216146.

E-mail address: ahmadraz@eng.ukm.my

negative impact, DGs add to fault current levels increase and multiple current flow paths during fault [1-6]. These conditions decrease the capability and reliability of the existing design of radial distribution system protection system. Since the introduction of microgrid concept, many attempts have been made to ensure a secure and reliable operation of the microgrid system. One important aspect that has drawn much interest from the researchers is the protection of the microgrid system. Ever since, many researchers have proposed and tested various type of protection schemes that could assist in the implementation of microgrid system. Some of the methods are based symmetrical current components, voltage measurements, current signals and impedance of the system [7-11]. Others use different protection devices such as microprocessor-based relays, differential relays, directional relays and etc [12-15]. These approaches have increased the chances of successful implementation and operation of microgrid system. In the mean time, much concern has been dedicated to the coordination of the protective devices that are used to protect the network since the characteristics of the microgrid is significantly different from the traditional radial distribution network. Particle swarm optimization and genetic algorithm are two widely used algorithms for optimal coordination of DOC relays in the microgrid system [16-18]. Though many algorithms have been proposed and tested, there is still plenty of room to study and evaluate new strategies to cater the new challenges which emerges from dynamic changes in microgrid topology and characteristics. Therefore, it is the intention and motivation of this work to study and propose a coordination strategy for successful microgrid protection and operation.

2. Protective relay coordination issues in a microgrid system

The aim for coordination of protection devices is to maintain the selectivity among the devices involved in several fault possibilities in order to assure safe operation and reliability of the system. In an efficient and coordinated protection system, faults are eliminated in the minimum possible time, isolating the smallest part of the system containing the cause of the fault [19]. This can be easily achieved in a traditional radial distribution network with unidirectional power flow. In such a system, the fault current reduces along the feeder, and hence coordinating the relay settings are straight forward.

However, once a microgrid is formed, the topology and characteristics are very much different from the traditional radial distribution network. It may operates either in grid-connected or islanded mode. The microgrid operating modes with DGs in the system changes the network characteristics in terms of variation in fault current levels and bi-directional power flow causing threats for a secure and reliable operation of microgrid. If the microgrid is derived from the conventional distribution network, the existing protective devices like non-directional OC relays, fuses and reclosers are now subjected to coordination problems as large number of distributed generators are added to the network. Moreover, protection miscoordination, such as fuse-fuse, recloser-fuse, breaker-breaker and relay-relay can significantly affect the reliability of the distribution system. Even though OC protection could be used to protect the network up to an extent, reliability could not be assured at all the time especially with large DGs and DGs are located randomly in the network. Furthermore, for a microgrid system with bidirectional power flow, the coordination of the protective devices are more complicated [20]. According to [21], for a microgrid to rely on protective relays using conventional techniques, certain problem would arise due to feeding effect to the fault from downstream sources and also the appreciable difference between the utility-grid connected mode and islanded mode of operation. For high degree of DGs penetration, protection coordination is critically affected by the changing fault current level and probable false tripping, protection blinding, undesirable network islanding and out-of-synchronism of reclosers.

Thus, dependence on OC relays without direction sensitive capability becomes inadequate and new strategy must be investigated to secure the microgrid operation. Combination of multiple relays appears to have good potential to resolve the protection issues associated with microgrid implementation. However, different relays with different characteristic require proper coordination strategy to allow successful microgrid operationability.

3. Proposed relays coordination strategy

A secure microgrid operation requires that any faults occurring inside the microgrid must be successfully cleared, regardless of its operating modes. The criteria for fault clearance are that the nearest device to the fault must trip first and the isolated area must be as smallest as possible. To fulfill these criteria, the proposed method relies on the

promising features of OC, DOC and DIF relays. For example, the OC, DOC and DIF relays are widely being used in distribution system protection to cater different protection goals. Therefore, the same protective devices are expected to have the capability to protect the system with proper coordination strategy. Secondly, the implementation of such relays could deter the high investment cost of microprocessor-based relays.

The coordination procedure is carried out according to the flowchart shown in Fig. 1. To implement the procedure, the microgrid system is first assumed as radial network without DG and it is protected by OC relay with inverse characteristic. However, when DG is added to the system, the fault current contribution was shared between the main source and the DG. The current flow becomes bidirectional and decrease the OC protection capability. During the line faults, the feeder OC relay could see the fault and trip to clear the fault. But, the fault current contribution from the DG still exists from the downstream locations. Therefore the scenario with only OC relay is not desirable as feeding effect from the DG would still imperil the microgrid system. This circumstance indicates a need for direction sensitive protection. Therefore DOC relay is incorporated at immediate upstream location of DG. DOC relay with direction sensitive characteristic could see the fault current flow in forward or reverse direction. Depending on tripping direction requirement, DOC relay could trip to clear the fault. Thus, with DOC relay, the feeding effect from DG during fault could be removed.

Once DOC relays are installed at immediate upstream locations of DGs, coordination among DOC relays is conducted to avoid miscoordination. The selectivity is ensured through different current setting and coordination time interval between the relays. The coordination is first checked for grid-connected operation mode by creating different types of faults at different fault locations. Once coordination is achieved for grid-connected mode, the process is repeated for islanded operation mode. The OC and DOC relays continue to use the coordination settings previously implemented in grid-connected mode of operation. The static switch is opened and coordination is checked again. If any miscoordination occurs, changes are required to DOC relays to conform to the coordination requirement. On the occasion of faults, the cooperative decision of both types of relays must be capable to isolate the faulty segment.

However, reliance on two types of protection schemes could not fulfill small area isolation during fault. Other protection issues like blinding and false tripping of OC protection also might occur [22]. In such situations, DIF relays are replaced for location that could not be protected by feeder OC relays. Incorporation of this type of relay as the last protection scheme reduces the number of equipment required for its implementation. When fault occur in its dedicated zone of protection, the relay trips because of the sum of current entering and leaving a protected section is not equal to zero. The use of this type of relays does not require coordination among them as their operation is specific to the dedicated zone only. Therefore, the operation of DIF relay is not affected by changes in the microgrid operation modes.

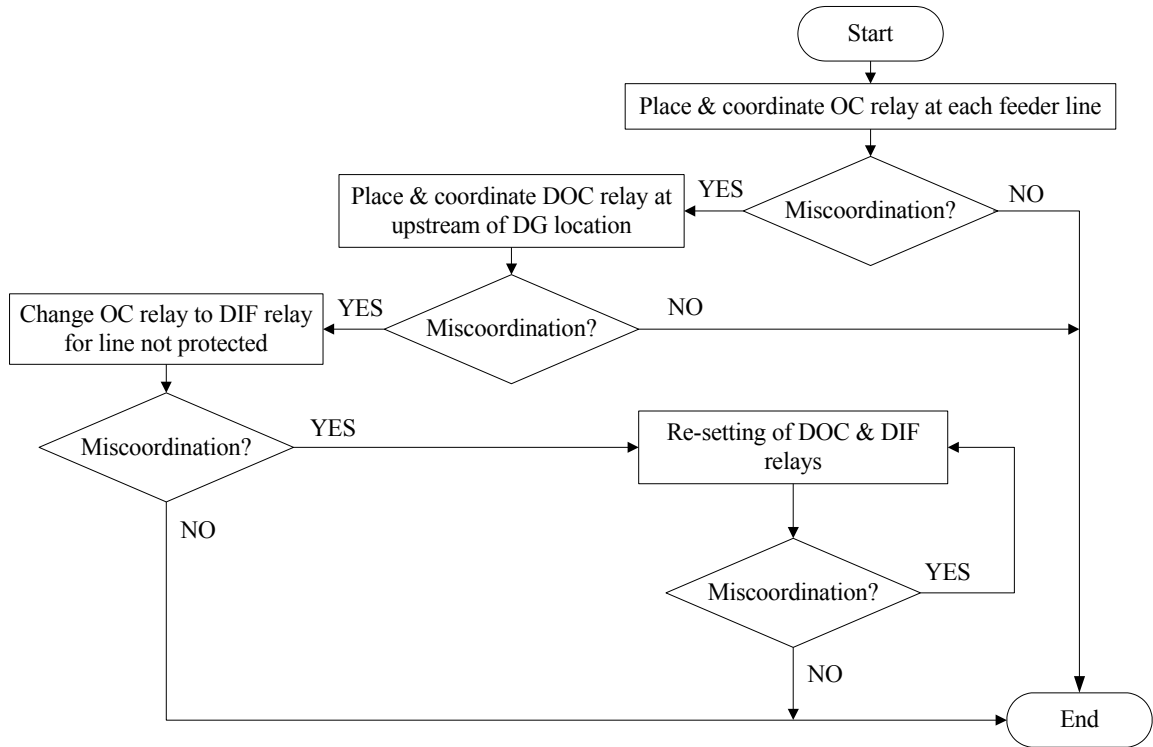

Fig. 1. Flowchart of the coordination process.

4. Protection coordination setup and simulation results

The coordination procedure proposed in previous section was tested in a test system adopted from the work reported in [16], which has been used for testing coordination of DOC relays. This system consists of 6 buses with two synchronous-based distributed generators installed at selected locations to form a microgrid as shown in Fig. 2. In the system, DGs are capable to supply the critical loads during lost of main supply. The test system is assumed to be radial at the first place before systematic coordination is applied. Initially, a radial system relies on OC relays as its protection scheme. The OC relays are located at the beginning of each feeder lines to protect the system. These relays are denoted as R7, R3, R2, R6 and R4 respectively. The capability of the OC relays to protect the microgrid is assessed for grid-connected and islanded mode of operation. As shown in Table 1, for a sample of three-phase short circuit at Line 3 in both modes of operation, the OC relay are capable to clear the fault current contributions from the upstream sources but at the downstream side, DGs still feed the fault current to the fault point. The prolonged fault event due to the feeding effect by DG may damage some equipment associated with the faulted section. Therefore, a direction sensitive relay is required at the DG location to remove the feeding effect during fault.

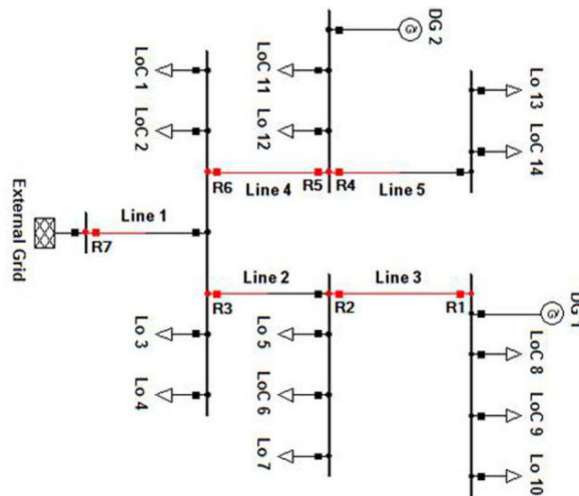

Fig. 2. Microgrid test system for simulation work

Table 1. Result for OC relays coordination in microgrid system

Mode of operation	Relay operating time for F1 fault at Line 3	Comments
Network without DG	R2(0.032s)	- R2 successfully clear the fault
Grid-connected	R2(0.026s)	- R2 clear the fault at the upstream but DG still feed to the fault
Islanded	R2(0.152s)	- R2 clear the fault at slower time and DG still feed to the fault

With DOC relays installed, the downstream part of the protected section can be disconnected and the faulty area is successfully isolated. DOC relays are placed at the immediate upstream of DG location which is denoted as R1 and R5 in the test system. To protect the microgrid, the protective relays are coordinated based on pickup current setting and time delay. The coordination of OC and DOC relays is again checked for grid-connected and islanded modes of operation. As shown in Table 2, for a three-phase fault at Line 2, the fault is cleared by OC relay R3 at 0.034s and DOC relay R1 at 0.127s. Although addition of DOC relays successfully clear faulty segment and diminish the feeding effect from DG, but for certain location in grid-connected and islanded microgrid operations, the isolation area is quite large and critical loads are left unsupplied. This scenario is undesirable for reliable microgrid operation. Therefore, DIF relay which is known for unit protection is added to the microgrid to minimize the isolation area.

Table 2. Result for OC and DOC relays coordination in microgrid system

Mode of operation	Relay operating time for F2 fault at Line 2	Comments
Grid-connected	R3(0.034s), R1(0.127s)	- Fault cleared with large isolation area
Islanded	R5(0.0.147s), R1(0.127s)	- Fault cleared with bigger isolation area

DIF relay is known for its superior unit protection which trip for only dedicated protection area. Since the isolated area by the protection based on OC and DOC relays is quite large, OC relay is replaced with DIF relay at certain location to minimize the isolation area. The DIF relays in the test system are denoted as R3, R6 and R7. During fault, the relays compare the incoming and outgoing currents measured by the current transformers at both ends of the feeder and tripping signals are send to the respective circuit breakers via communication to clear the

fault. Table 3 shows the results for coordination of OC, DOC and DIF relays during grid-connected and islanded modes of operation.

Table 3. Result for OC, DOC and DIF relays coordination in microgrid system

Mode of operation	Relay operating time for F2 fault at Line 2		Comments
Grid-connected	R3(0.037s)	-	Fault cleared successfully with smallest possible area
Islanded	R3(0.037s)	-	Fault cleared successfully with smallest possible area

A sample of a three-phase fault at Line 2 prompts operation of DIF relay R3 which clears the fault by opening circuit breakers at both ends of the line. The isolation area is minimized to the smallest possible area and the DGs can continue to supply the critical loads. Finally, the complete coordination procedures involving the three types of relays are shown to be able to protect the microgrid from fault during grid-connected and islanded modes of operation. Table 4 shows the summary of relays inside the microgrid after three stages of coordination.

Table 4. Relay coordination stages

Relay	R1	R2	R3	R4	R5	R6	R7
Stage 1	-	Overcurrent	Overcurrent	Overcurrent	-	Overcurrent	Overcurrent
Stage 2	Directional overcurrent	Overcurrent	Overcurrent	Overcurrent	Directional overcurrent	Overcurrent	Overcurrent
Stage 3	Directional overcurrent	Overcurrent	Differential	Overcurrent	Directional overcurrent	Differential	Differential

Once all relays are selected and incorporated into the microgrid system, simulation was carried out to evaluate the effectiveness of the protection scheme as well as its coordination strategy. Sample results are obtained and presented to show the effectiveness and capability of the protection scheme and coordination strategy to protect the microgrid, regardless of operation modes. As shown in Table 5, the respective primary relays respond excellently to different type of faults at different locations. The isolated section also was minimized to the smallest possible area. Topology changes i.e. from grid-connected to islanded mode show no effect to the coordination of the protective devices.

Table 5. Relay operating times for three-phase fault at different locations and different microgrid topology

Fault name & location	Relay operating time for fault during grid-connected mode		Relay operating time for fault during islanded mode	
F1 (Line 3)	R1 (0.126s)	R2 (0.026s)	R1 (0.127s)	R2 (0.138s)
F2 (Line 2)	R3 (0.037s)	R3 (0.037s)	R3 (0.037s)	R3 (0.037s)
F3 (Line 5)	R4 (0.011s)	-	R4 (0.028s)	-
F4 (Line 4)	R5 (0.147s)	R6 (0.037s)	R5 (0.147s)	R6 (0.037s)
F5 (Line 1)	R7 (0.037s)	R7 (0.037s)	R7 (0.037s)	R7 (0.037s)

Fig. 3 shows an example of fault currents seen by the three relays and their operating status for a three-phase fault at Line 3 during grid-connected operation mode. As can be seen from the figure, OC relay R2 and DOC relay R1 was successfully tripped when the fault current exceeds their pickup and direction settings respectively. Although DIF relay R3 also could sees the fault current, but the sum of fault current seen by current transformers at both ends of the line equals zero, therefore no tripping occurs, leaving the faulty segment to the smallest area.

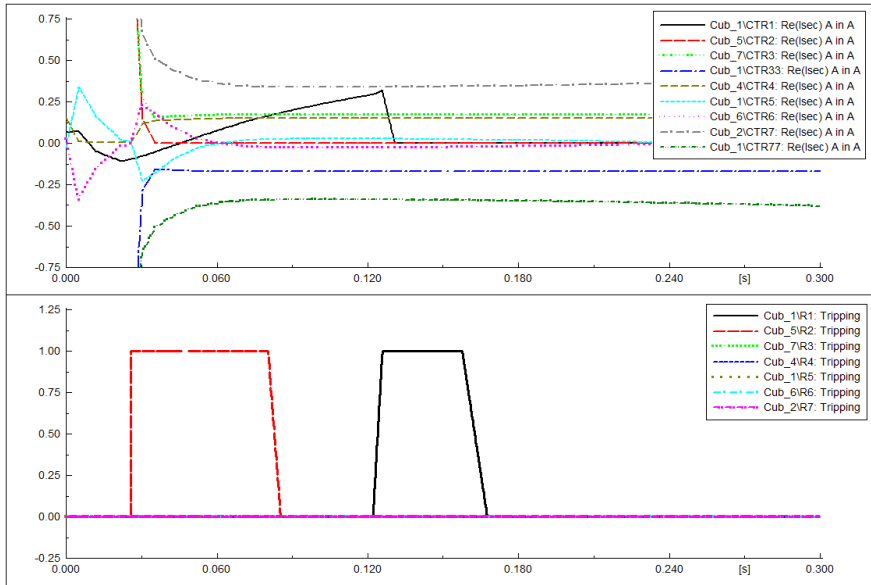

Fig. 3. Fault currents flow through current transformers and relay tripping status during a three-phase fault at Line 3 in grid-connected microgrid.

Fig. 4 shows the fault current seen by respective relays and their operating status during a three-phase fault in Line 3 when microgrid is islanded from the main grid. Current transformers at both ends of Line 3 could see sufficient fault current level for the relays to trigger the circuit breakers. Subsequently relays R1 and R2 trip to isolate the faulty segment. Testing for different type of faults affirms the operationability of the protection schemes and systematic coordination to protect the microgrid without changing the protection settings.

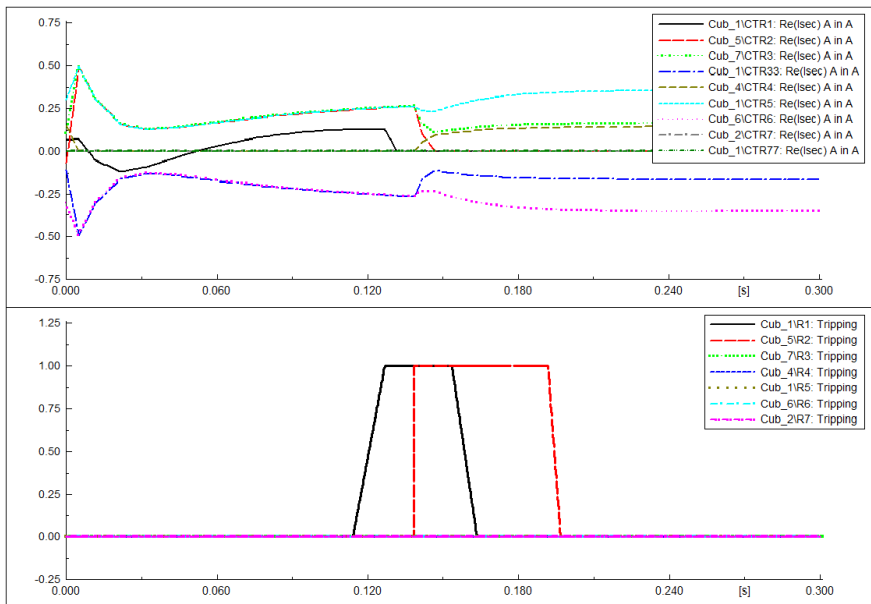

Fig. 4. Fault currents flow through current transformers and relay tripping status during a three-phase fault at Line 3 in islanded microgrid.

5. Conclusion

In this paper, a new protection strategy with systematic coordination approach has been demonstrated using combination of three types of protection relays namely overcurrent, directional, and differential relays. It is based on the fact that, although OC relays are known for superiority in protection of radial distribution system, the same are found incapable to protect a network with some distributed generators on grid. Simulation results proved that addition of DOC relays could help to improve the network security but dependency is insufficient to isolate the smallest possible area. Further tests show that by combining OC, DOC, and DIF relays, it is possible to successfully protect the microgrid with topology changes. However, aggressive simulations of different test systems are still needed to verify the effectiveness of protection scheme and coordination algorithm.

References

- [1] Sarabia AF. Impact of distributed generation on distribution system. Aalborg, Denmark: Aalborg University; 2011.
- [2] Zheng KH, Xia MC. Impacts of microgrid on protection of distribution networks and protection strategy of microgrid. Proceedings of the The International Conference on Advanced Power System Automation and Protection; 2011. p. 356-359.
- [3] Conti S. Protection issues and state of the art for microgrids with inverter-interfaced distributed generators. Proceedings of the International Conference on Clean Electrical Power (ICCEP); 2011. p. 643-647.
- [4] Conti S. Analysis of distribution network protection issues in presence of dispersed generation, Elec Power Syst Res; 2009. p. 49-56.
- [5] Hussain B, Sharkh SM, Hussain S. Impact studies of distributed generation on power quality and protection setup of an existing distribution network. Proceedings of the International Symposium on Power Electronics Electrical Drives Automation and Motion (SPEEDAM); 2010. p. 1243-1246.
- [6] Kauhaniemi K, Kumpulainen L. Impact of distributed generation on the protection of distribution networks. Proceedings of the Eighth IEEE International Conference on Developments in Power System Protection; 2004. p. 315-318 Vol.311.
- [7] Al-Nasseri H, Redfern MA. Harmonics content based protection scheme for micro-grids dominated by solid state converters. Proceedings of the 12th International Middle-East Power System Conference (MEPCON); 2008. p. 50-56.
- [8] Al-Nasseri H, Redfern MA, Li F. A voltage based protection for micro-grids containing power electronic converters. Proceedings of the IEEE Power Engineering Society General Meeting; 2006. p. 1-7.
- [9] Ustun TS, Ozansoy C, Zayegh A. A central microgrid protection system for networks with fault current limiters. Proceedings of the Environment and Electrical Engineering (EEEIC); 2011. p. 1-4.
- [10] Microgrid fault protection based on symmetrical and differential current components, Public Interest Energy Research California Energy Commission; 2006.
- [11] Haron AR, Mohamed A, Shareef H. A review on protection schemes and coordination techniques in microgrid system. Journal of Applied Sciences; 2012. p. 101-112.
- [12] Dewadasa JM, Ghosh A, Ledwich G. Distance protection solution for a converter controlled microgrid. Proceedings of the 15th National Power Systems Conference (NPSC); 2008. p. 1-6.
- [13] Dewadasa M, Ghosh A, Ledwich G. Protection of microgrids using differential relays. Proceedings of the 21st Australasian Universities Power Engineering Conference (AUPEC); 2011. p. 1-6.
- [14] Sortomme E, Venkata SS, Mitra J. Microgrid protection using communication-assisted digital relays. IEEE Trans Power Deliv; 2010. p. 2789-2796.
- [15] Zamani MA, Sidhu TS, Yazdani A. A protection strategy and microprocessor-based relay for low-voltage microgrids. IEEE Trans Power Deliv; 2011. p. 1873-1883.
- [16] Zeineldin HH, El-Saadany EF, Salama MMA. Protective relay coordination for micro-grid operation using particle swarm optimization. Proceedings of the Large Engineering Systems Conference on Power Engineering; 2006. p. 152-157.
- [17] Damchi Y, Mashhadi HR, Sadeh J, Bashir M. Optimal coordination of directional overcurrent relays in a microgrid system using a hybrid particle swarm optimization. Proceedings of the International Conference on Advanced Power System Automation and Protection (APAP); 2011. p. 1135-1138.
- [18] Qu H, Jia Q, Bo Z. MPSO based protective relay coordination for micro-grid. Proceedings of the Managing the Change, 10th IET International Conference on Developments in Power System Protection (DPSP 2010); 2010. p. 1-5.
- [19] de Britto TM, Morais DR, Marin MA, Rolim JG, Zurn HH, Buendgens RF. Distributed generation impacts on the coordination of protection systems in distribution networks. Proceedings of the Transmission and Distribution Conference and Exposition: Latin America, 2004 IEEE/PES; 2004. p. 623-628.
- [20] Protection of meshed microgrids, CSIRO Intelligent Grid Research Cluster.
- [21] Khederzadeh M. Integration of renewables into the distribution grid needs new software tools for coordination of protective devices. Proceedings of the CIRED Workshop; 2012. p. 1-4.
- [22] Haron AR, Mohamed A, Shareef H. Analysis and solutions of overcurrent protection issues in a microgrid. Proceedings of the IEEE International Conference on Power and Energy (PECon); 2012. p. 626-631.