

## Mutations of SURF-1 in Leigh Disease Associated with Cytochrome *c* Oxidase Deficiency

Valeria Tiranti,<sup>1</sup> Konstanze Hoertnagel,<sup>3</sup> Rosalba Carrozzo,<sup>4</sup> Claudia Galimberti,<sup>1</sup> Monica Munaro,<sup>1</sup> Matteo Granatiero,<sup>5</sup> Leopoldo Zelante,<sup>5</sup> Paolo Gasparini,<sup>5</sup> Rosalia Marzella,<sup>6</sup> Mariano Rocchi,<sup>6</sup> M. Pilar Bayona-Bafaluy,<sup>7</sup> Josè-Antonio Enriquez,<sup>7</sup> Graziella Uziel,<sup>1</sup> Enrico Bertini,<sup>4</sup> Carlo Dionisi-Vici,<sup>4</sup> Brunella Franco,<sup>2</sup> Thomas Meitinger,<sup>3</sup> and Massimo Zeviani<sup>1</sup>

<sup>1</sup>Istituto Nazionale Neurologico “Carlo Besta” and <sup>2</sup>Téléthon Institute for Genetics and Medicine, Milan; <sup>3</sup>Abteilung Medizinische Genetik, Kinderklinik der Ludwig-Maximilians Universität München, Munich; <sup>4</sup>Ospedale Pediatrico “Bambino Gesù,” Rome; <sup>5</sup>Casa Sollievo della Sofferenza, S. Giovanni Rotondo, Italy; <sup>6</sup>Università Statale di Bari, Bari, Italy; and <sup>7</sup>Universidad de Zaragoza, Zaragoza, Spain

### Summary

Leigh disease associated with cytochrome *c* oxidase deficiency (LD<sup>(COX<sup>-</sup>)</sup>) is one of the most common disorders of the mitochondrial respiratory chain, in infancy and childhood. No mutations in any of the genes encoding the COX-protein subunits have been identified in LD<sup>(COX<sup>-</sup>)</sup> patients. Using complementation assays based on the fusion of LD<sup>(COX<sup>-</sup>)</sup> cell lines with several rodent/human rho<sup>0</sup> hybrids, we demonstrated that the COX phenotype was rescued by the presence of a normal human chromosome 9. Linkage analysis restricted the disease locus to the subtelomeric region of chromosome 9q, within the 7-cM interval between markers D9S1847 and D9S1826. Candidate genes within this region include SURF-1, the yeast homologue (SHY-1) of which encodes a mitochondrial protein necessary for the maintenance of COX activity and respiration. Sequence analysis of SURF-1 revealed mutations in numerous DNA samples from LD<sup>(COX<sup>-</sup>)</sup> patients, indicating that this gene is responsible for the major complementation group in this important mitochondrial disorder.

### Introduction

Subacute necrotizing encephalomyelopathy, also known as “Leigh disease” (LD; MIM 256000), is one of the most common disorders of the respiratory chain, in infancy and childhood. Biochemically, a generalized defect

of respiratory complex IV (cytochrome *c* oxidase [COX]) was found in the majority of our patients (Zeviani et al. 1996), although deficiencies of the pyruvate dehydrogenase complex, respiratory complexes I (Rahman et al. 1996) or II (Bourgeron et al. 1995), and mtDNA point mutations (Santorelli et al. 1993) have been reported by others.

COX (E.C.1.9.3.1), the terminal component of the mitochondrial respiratory chain, is a multiheteromeric enzyme embedded in the mitochondrial inner membrane. This complex consists of a protein backbone bound to two copper-containing prosthetic groups, the cytochromes *a* and *a3* (Babcock and Wikström 1992). Human COX is composed of 13 subunits: the 3 largest are encoded by mtDNA genes, whereas the remaining subunits are encoded by nuclear genes (Taanman 1997). The sequences of the genes encoding all the COX subunits have been determined completely in humans (Anderson et al. 1981; Grossman and Lomax 1997). No mutations in any of the COX-encoding nuclear genes have been found in patients with COX deficiency (Jaksch et al. 1998).

We have demonstrated previously that most cases of LD associated with COX deficiency (LD<sup>(COX<sup>-</sup>)</sup>) belong to one complementation group (Munaro et al. 1997). However, at least two additional complementation groups have been identified (Brown and Brown 1996; V. Tiranti, C. Galimberti, and M. Zeviani, unpublished data). Whether these complementation groups are the result of mutations in different genes or whether they represent allelic variants of the same gene is still unclear.

To identify an LD<sup>(COX<sup>-</sup>)</sup> locus, we set up a three-step strategy. First, we determined that most of the human autosome does not contain the disease locus, by using complementation of two LD<sup>(COX<sup>-</sup>)</sup> cell lines, belonging to the same complementation group, with several rodent/human hybrids containing either single human chromosomes or panels of different human chromosomes. Before fusion, the rodent/human hybrids were

Received June 22, 1998; accepted for publication October 13, 1998; electronically published November 25, 1998.

Address for correspondence and reprints: Dr. Massimo Zeviani, Divisione di Biochimica e Genetica, Istituto Nazionale Neurologico “Carlo Besta,” via Celoria 11, 20133 Milano, Italy. E-mail: zeviani@tin.it

© 1998 by The American Society of Human Genetics. All rights reserved. 0002-9297/98/6306-0007\$02.00

made  $\rho^0$  (i.e., were deprived of their own mtDNA) by prolonged exposure to high doses of ethidium bromide (EtBr). Complementation of the COX defect was obtained only with rodent/human  $\rho^0$  hybrids that contained human chromosome 9. In the second step, linkage analysis of nine LD<sup>(COX<sup>-</sup>)</sup> families belonging to the same COX complementation group narrowed the critical region for an LD<sup>(COX<sup>-</sup>)</sup> locus to a 7-cM interval on chromosome 9q34.

Finally, we performed a mutation analysis of candidate genes, including the endonuclease G (ENDOG), matrix-processing protease (MPP), and surfeit-1 (SURF-1) genes. The latter is the human analogue of SHY-1, a yeast gene whose product is targeted to mitochondria and whose mutations impair mitochondrial respiration (Mashkevich et al. 1997). SURF-1 was mutated in the probands of nine LD<sup>(COX<sup>-</sup>)</sup> families; in the probands of six families, loss-of-function mutations were found on both alleles.

## Patients, Material, and Methods

### *Patients and Clinical Criteria for Inclusion*

We studied 11 patients, belonging to nine families, some of whom were described in an earlier report (Munaro et al. 1997). All patients shared an apparently identical, rapidly progressive encephalopathy, characterized by the following features: early onset; generalized hypotonia with brisk tendon reflexes; truncal ataxia; oculomotor abnormalities, including slow saccades, ophthalmoparesis, or complex irregular eye movements; “central” abnormalities of ventilation, including episodes of apnea and irregular hyperpnea; and rapidly progressive psychomotor regression, leading to death from central ventilatory failure. For all patients, a computed-tomography scan or magnetic-resonance imaging revealed the presence of symmetric lesions scattered from the basal ganglia to the brain stem, including the cerebellum. In one case (the affected individual in family D), necropsy examination showed the presence of necrotic lesions associated with glial and vascular proliferation, as is typically described in subacute necrotizing encephalomyelopathy.

Biochemically, lactic acid in blood and urine was above normal range, and a muscle-biopsy examination showed a severe decrease of the histochemical reaction to COX. Ragged-red fibers consistently were absent in all cases. An isolated defect of COX (5%–10% of normal values) was detected in fibroblasts and muscle homogenates from all patients.

### *Cell Lines, Rodent/Human Hybrids, and Creation of $\rho^0$ Derivatives*

The recombinant plasmid pBABE40 was created by insertion of an origin-defective SV40 genome excised by *Eco*RI digestion of plasmid pRNS (Tiranti et al. 1995) into plasmid pBABE, a vector expressing the gene conferring resistance to puromycin (Munaro et al. 1997). Therefore, pBABE40 expresses both the transformant activity of the SV40 genome and resistance to puromycin. The pBABE40 recombinant plasmid was stably transfected (Tiranti et al. 1995) into two COX-defective fibroblast cell lines from LD<sup>(COX<sup>-</sup>)</sup> patients belonging to the same complementation group (subjects S and M, described by Munaro et al. [1997]) and into a COX-positive fibroblast cell line from a normal individual (subject A). The COX-defective transformant cell lines were called “SpBABE40” and “MpBABE40,” and the COX-positive control transformant cell line was called “ApBABE40.”

The following monochromosomal hybrids (Coriell Cell Repository) were used in the experiments: GM13139 (containing human chromosome 1), GM11712 (chromosome 2), GM11713 (chromosome 3), GM11714 (chromosome 5), GM10611A (chromosome 9), GM11688 (chromosome 10), GM11689 (chromosome 13), and GM13260 (chromosome 20). GM10611A is a hamster/human somatic cell hybrid in which the human chromosome 9 expresses a gene conferring resistance to histidinol, a reversible inhibitor of protein synthesis. The other hybrids listed above are mouse/human hybrids in which each human chromosome expresses the gene conferring resistance to neomycin. Somatic hamster/human cell hybrids Y.XY.8F6, HY.166T4, and HY.137J have been described elsewhere (Rocchi et al. 1986). For some experiments, the mouse L929 cell line and the hamster B14150 cell line were also used.

All the somatic cell hybrids, as well as the mouse L929 and hamster B14150 cell lines, were exposed continuously to 5  $\mu$ g EtBr/ml in a  $\rho^0$ -permissive medium (Dulbecco's modified Eagle's medium [DMEM]/uridine; see “Fusion Procedure and Cell Cultures”) for 8–12 wk, until the complete absence of endogenous mtDNA (and mitochondrial OXPHOS) was proved for each of them. The presence or absence of mouse or hamster mtDNA was tested periodically by PCR amplification of species-specific mtDNA sequences. The test sequences were as follows: (1) a fragment in the human mtDNA D-loop, spanning nucleotides (nts) 16130–500 (Anderson et al. 1981); (2) a fragment in the mouse mtDNA D-loop, spanning nts 15431–16281 (Bibb et al. 1981); and (3) a portion of the ATPase 6-URFA6L genes of hamster mtDNA, spanning nts 60–767 (Breen et al. 1986). The

rho<sup>0</sup> derivatives were named by addition of the suffix “ρ<sup>0</sup>” to the corresponding cell lines.

#### *Cytogenetic Analysis*

The human-chromosome content of the EtBr-treated hybrids was assessed by reverse FISH. In brief, DNA extracted from the hybrids was dual *Alu*-PCR amplified, as described elsewhere (Liu et al. 1993). The PCR products were biotin labeled by nick translation and were used as a probe for FISH experiments on normal human metaphases obtained from phytohemagglutinin-stimulated peripheral blood lymphocytes. In some instances, the human-chromosome content was also checked, by hybridization of biotin-labeled total human DNA on metaphases obtained from the hybrid. In all FISH experiments, chromosome identification was obtained by diamidino-phenylindole (DAPI) counterstaining. The presence of chromosome 9 in interphase nuclei from parental cells and from fused cells was screened by FISH experiments using the alphoid probe pMR9A, which specifically recognizes the centromeric region of chromosome 9 (Rocchi et al. 1991). FISH experiments were performed essentially as described elsewhere (Lichter et al. 1990).

Digital images were obtained by use of a Leica epifluorescence microscope (model DMRXA) equipped with a cooled charge-coupled device (Princeton Instruments). Cy3 (Amersham) and DAPI fluorescence signals, detected with specific filters, were recorded separately as gray-scale images. Pseudocoloring and merging of images were performed by use of Adobe Photoshop commercial software.

#### *Fusion Procedure and Cell Cultures*

Approximately  $0.5 \times 10^6$  cells from the fibroblast cell lines SpBABE40, MpBABE40, or ApBABE40 were cocultured with  $0.5 \times 10^6$  cells from each rho<sup>0</sup> cell derivative, in a rho<sup>0</sup>-permissive medium composed of DMEM containing 4.5 g glucose/liter and 110 μg pyruvate/ml, supplemented with 5% fetal bovine serum (Boehringer) and 50 μg uridine/ml (DMEM/uridine). After incubation for 1 d, fusion was performed by treatment of the confluent cell monolayer with a 50% (weight/volume) solution of polyethylene-glycol (PEG) in a phosphate buffer, pH 7.4. Twenty-four hours after fusion, cells were trypsinized and replated in a uridine-less DMEM medium containing 0.5 μg puromycin/ml, to select against the unfused, puromycin-sensitive rho<sup>0</sup> cell derivatives. Selection against the unfused parental fibroblast cell lines was performed by addition of 200 μg/ml of the neomycin analogue drug G418, for the fusions with human/mouse monochromosome rho<sup>0</sup> hybrids expressing the neomycin-resistance gene, or of 7 mM histidinol, for the fusions with histidinol-resistant human/hamster monochromo-

some 9-specific GM10611A-ρ<sup>0</sup>. The histochemical and biochemical assays were performed 3–4 d after fusion and were repeated after at least 2 wk of continuous selection.

#### *Cytochemical and Biochemical Assays*

COX activity was visualized cytochemically in cell cultures grown on coverslips, as described elsewhere (Tiranti et al. 1995). Cell homogenates were prepared in accordance with the digitonin-based method described by Robinson et al. (1986), modified as described by Tiranti et al. (1995). The enzyme activities of COX were measured twice in each assay (Darley-Usmar et al. 1987). Protein concentration was measured by the method of Lowry et al. (1951). Activities were expressed as nanomoles of substrate/min/mg protein. We did not normalize the respiratory-chain activities for citrate synthase, because citrate synthase is also expressed at high levels in the rho<sup>0</sup> mitochondria. This could have underestimated the respiratory activities in the rho<sup>0</sup>-derived hybrids.

#### *Linkage Analysis*

Informed consent was obtained from the parents and the adult sibs of the probands of seven families. The members of two families could not be reached, and the analysis was performed by use of genomic DNA extracted from fibroblast cell lines stored in our laboratory. A disease frequency of 1/100,000, which accounts for the rarity of LD<sup>(COX<sup>-</sup>)</sup>, and an autosomal recessive pattern of inheritance were considered in the linkage analysis. The fluorescent oligonucleotide primers of the ABI Prism Linkage Mapping Set (Applied Biosystems) were used to PCR amplify a panel of 14 microsatellite markers regularly distributed along human chromosome 9; the order of the markers is as follows: pter-D9S288-D9S286-D9S157-D9S171-D9S161-D9S273-D9S175-D9S167-D9S283-D9S287-D9S279-D9S1831-D9S164-D9S1826-qter. A second run of PCR amplifications using fluorescent oligonucleotides as primers was performed to analyze three additional microsatellite markers (D9S1847, D9S1793, and D9S1818) in the subtelomeric region of chromosome 9q. The genetic intermarker distances and the order of markers on chromosome 9 were based on published information. Microsatellites were PCR amplified by following the instruction manual of the ABI Prism Linkage Mapping Set (version 2) and were analyzed in an ABI-377 automated sequencer, by use of the GENESCAN and GENOTYPER software packages (Applied Biosystems). The linkage analyses were performed by use of the MLINK and ILINK options of the LINKAGE program package (version 5.1; Lathrop et al. 1984). The test for heterogeneity was performed by use of the pairwise LOD scores for each

family as an input file for the HOMOG program (version 3.37; Ott 1991).

#### Identification of Candidate Genes and Sequence Analysis

The database MITOP was used to identify mapped expressed sequence tags (ESTs) and genes encoding putative mitochondrial proteins. MITOP presently includes two categories of human mitochondrial genes with given map positions: (1) mapped Unigene clusters of ESTs homologous to yeast mitochondrial genes and (2) mapped genes encoding mammalian mitochondrial proteins.

The MITOP tool “human ESTs,” which is included in each individual entry of yeast proteins, provided a list of the best human-EST hits. A graphical alignment of EST clusters to the related yeast reference sequence and hyperlinks to Unigene helped to identify mapped EST clusters. The tool MITOPROT, a software package developed for the characterization of mitochondrial proteins (Claros 1995), was used to find mitochondrial targeting sequences and to calculate the probability of the import of proteins into mitochondria.

ENDOG and MPP cDNAs were amplified by reverse-transcription PCR (cDNA cycle kit, Invitrogen) from total RNA extracted from the cells of two patients and were sequenced with both sense and antisense primers. The nine exons of the SURF-1 gene were amplified from genomic DNA, by use of intronic primers (table 1). Both forward and reverse sequences were analyzed by use of an automated ABI-377 PRISM sequencer.

## Results

### Creation of Rodent and Rodent/Human $\rho^0$ Cell Lines

Prolonged exposure to 5  $\mu$ g EtBr/ml, a concentration 100-fold higher than that used to produce human  $\rho^0$  cells, resulted in the progressive elimination of endogenous mtDNA in our rodent cell lines and human/rodent somatic cell hybrids. In order to maintain the human

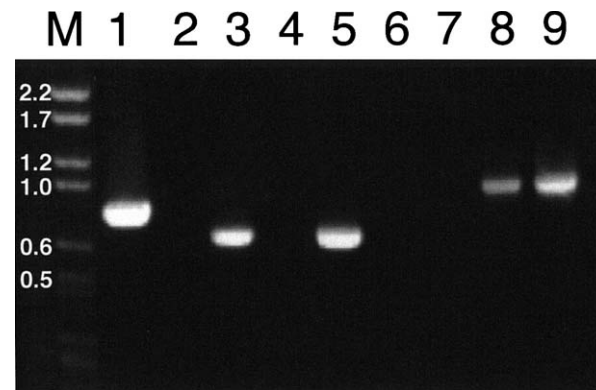

**Figure 1** PCR-based detection of mtDNA. Lane 1, Mouse-specific mtDNA fragment amplified from mouse L929 cells. Lane 2, Same fragment as in lane 1. No amplification was obtained from an L929- $\rho^0$  derivative. Lane 3, Hamster-specific mtDNA fragment amplified from hamster B14150 cells. Lane 4, Same fragment as in lane 3. No amplification was obtained from a B14150- $\rho^0$  derivative. Lane 5, Hamster-specific mtDNA fragment amplified from chromosome 9-containing GM10611A. Lane 6, Same fragment as in lane 5. No amplification was obtained from a GM10611A- $\rho^0$  derivative. Lane 7, Hamster mtDNA fragment. No amplification was obtained from a SpBABE40 + GM10611A- $\rho^0$  fusion. Lane 8, Human-specific mtDNA fragment amplified from an SpBABE40 cell line. Lane 9, Same fragment as in lane 8, amplified from an SpBABE40 + GM10611A- $\rho^0$  fusion.

chromosomes during the EtBr treatment, the somatic cell hybrids containing single human chromosomes were cultured in the presence of either G418 (a neomycin analogue) or histidinol, in accordance with the specific resistance expressed by the human chromosome contained in the hybrid (see Patients, Material, and Methods).

Neither rodent nor human mtDNA was detected, by PCR, in any of the  $\rho^0$  cell lines after cessation of treatment with EtBr. An example of these results is shown in figure 1. As expected, COX activity was absent as well; examples of these results are shown in figures 2 and 3.

**Table 1**

#### Primers for PCR Amplification of Exons 1–9 of SURF-1

Exon(s)	Oligonucleotide Sequences	Fragment Size (bp)	PCR Cycle
1 and 2 <sup>a</sup>	Sense: 5'-ATGCAGATGCTTCCTGCGTC-3'; Antisense: 5'-CAGACAGCAGGTGGCTCTGC-3'	297	94°C, 1 min; 56°C, 1 min; 72°C, 1 min
3 and 4	Sense: 5'-TTCGAGGGCTTCTGGCTCCA-3'; Antisense: 5'-AAGTAAAACAGGCCCTAGG-3'	380	94°C, 45 s; 60°C, 1 min; 72°C, 45 s
5	Sense: 5'-CAAACCTTGCTCGGCCACTG-3'; Antisense: 5'-TCTGCCAGGACAGCCAGCTC-3'	275	94°C, 45 s; 64°C, 1 min; 72°C, 45 s
6 and 7	Sense: 5'-CCACCTGAAGTAGCACTTTC-3'; Antisense: 5'-AGCTACTTGTTCCGAGATGG-3'	389	94°C, 45 s; 52°C, 1 min; 72°C, 45 s
8 and 9	Sense: 5'-AGAGGCTGGCAGGCCAGTAG-3'; Antisense: 5'-CTGCATTATCCAGGGACAGGG-3'	318	94°C, 45 s; 60°C, 1 min; 72°C, 45 s

<sup>a</sup> For PCR amplification, the following buffer was used (final concentration): 50 mM KCl; 20 mM Tris-HCl, pH 8.4; 3.5% formamide; 2 mM MgCl<sub>2</sub>; and 12% glycerol.

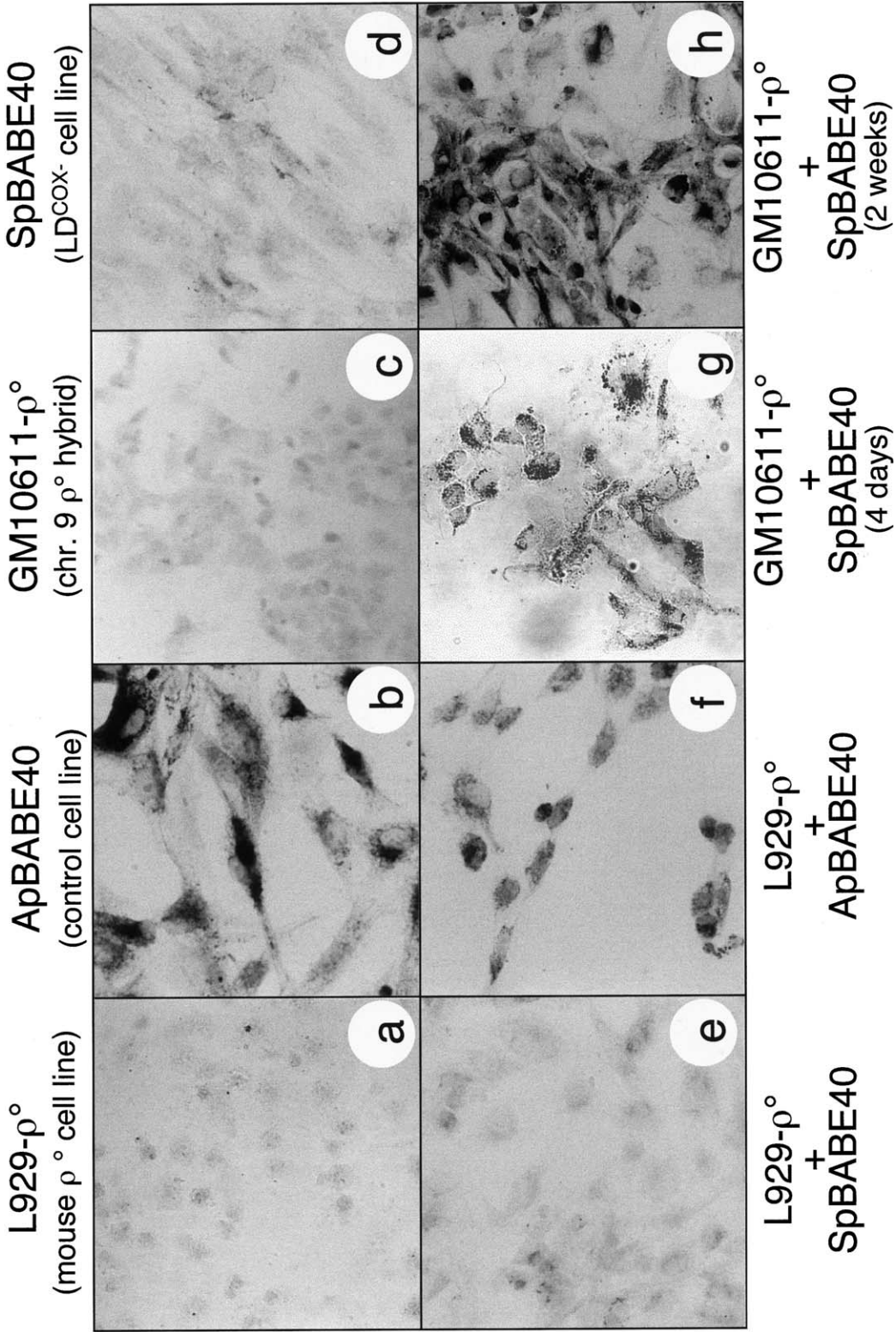
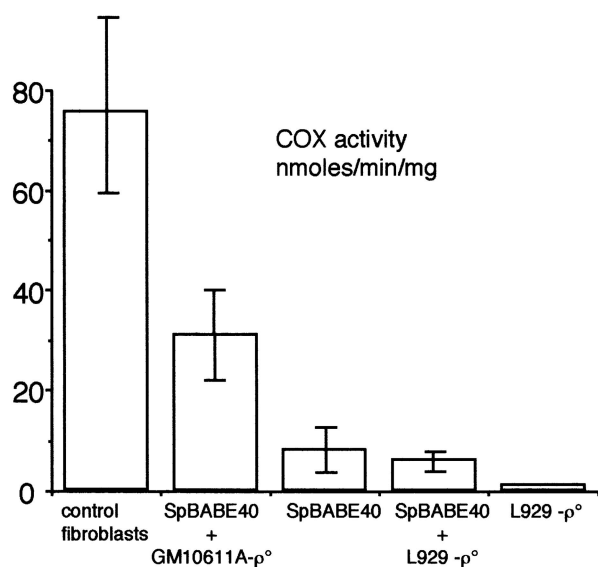

Figure 2   Histochemical reaction to COX, in different cell lines



**Figure 3** COX-specific activities in different cell lines (see Results).

The presence of the specific human chromosomes in each of the  $\rho^0$  rodent/human cell lines obtained after EtBr treatment was investigated by reverse FISH. Examples of the results of these experiments are shown in figure 4A–C. In addition, we prepared three rodent/human  $\rho^0$  hybrids containing different sets of human chromosomes in a hamster nuclear background (hybrids Y.XY.8F6- $\rho^0$ , HY.166T4- $\rho^0$ , and HY.137J- $\rho^0$ ). After EtBr treatment, these hybrids retained human chromosomes X, 3–7, 10–12, 17, 19, and 22 (Y.XY.8F6- $\rho^0$ ); 7 and 21 (HY.166T4- $\rho^0$ ); and 12, 20, 22, and the fragment 11p11.2–11q14 (HY.137J- $\rho^0$ ). Examples of these results are shown in figure 4D and E. Identification of the human-chromosome content in these hybrids was achieved by means of molecular cytogenetic approaches, the results of which are shown in figure 4, or by means of direct analysis by Q banding (data not shown).

#### COX-Complementation Assays

The mouse L929- $\rho^0$  cell line lacked COX activity (fig. 2a). Identical results were obtained for all the rodent/human  $\rho^0$  cell lines, as well as for the hamster B14150- $\rho^0$  cell line (not shown). As shown in figure 2e, a hybrid obtained by fusion of the mouse L929- $\rho^0$  cell line (fig. 2a) with an LD<sup>(COX<sup>-</sup>)</sup> patient's transformant cell line (fig. 2d), called "SpBABE40," did not rescue the COX phenotype, indicating that the rodent nuclear background was unable to complement the human COX defect. By contrast, a hybrid obtained by fusion of the same mouse L929- $\rho^0$  cell line with ApBABE40 (fig. 2b), a human puromycin-resistant control transformant fibroblast cell

line, displayed a normal immunocytochemical reactivity to COX (fig. 2f), indicating that the heterologous cell fusion did not inhibit the activity of the enzyme. These results were obtained consistently in several independent experiments, by use of different conditions and cell lines (including the hamster B14150- $\rho^0$  cell line). On the basis of these findings, we concluded that the rodent background did not interfere with the expression of the COX phenotype, at least during the period of our observations (up to 3 wk after fusion); therefore, this system could be used to identify the human chromosome containing a disease-complementing locus.

We then performed a series of PEG fusions between the LD<sup>(COX<sup>-</sup>)</sup> SpBABE40 cell line and each of our rodent/human  $\rho^0$  hybrid derivatives. No histochemical evidence of COX complementation was obtained for the  $\rho^0$  hybrid derivatives containing the single human chromosomes 1–3, 5, 10, 13, and 20. Likewise, no complementation was detected in fusions between SpBABE40 and the human/hamster hybrids Y.XY.8F6- $\rho^0$ , HY.166T4- $\rho^0$ , and HY.137J- $\rho^0$ , which together contained human chromosomes X, 3–7, 10–12, 17, 19, 20–22, and the fragment 11p11.2–11q14. From this work, we concluded that most of the human genome did not contain a gene complementing the COX defect in our cell line. Fusion of the LD<sup>(COX<sup>-</sup>)</sup> SpBABE40 cell line with the hamster/human somatic cell  $\rho^0$  derivative GM10611A- $\rho^0$  (fig. 2c), which contained chromosome 9 as the only human contribution, did show the presence of numerous COX-positive cells as early as 4 d after fusion (fig. 2g), indicating complementation of the COX defect. A more generalized positive COX reaction was obtained after a 2-wk selection of the same fusion, by use of puromycin and histidinol in a uridine-less medium (fig. 2h). The same results were obtained in two additional fusion experiments, by use of either SpBABE40 or another LD<sup>(COX<sup>-</sup>)</sup> cell line (MpBABE40, see Patients, Material, and Methods) as the proband cell line and of GM10611A- $\rho^0$  as the chromosome 9-donor cell line (data not shown). Reverse FISH of hybrids Y.XY.8F6- $\rho^0$ , HY.166T4- $\rho^0$ , and HY.137J- $\rho^0$  (as well as of the corresponding  $\rho^+$  progenitors) did not show the presence of chromosome 9.

Functional complementation was verified by measurement of COX-specific activity in cell homogenates from the different fusions (fig. 3). A 4–5-fold increase in COX activity was obtained in all the several SpBABE40 + GM10611A- $\rho^0$  fusions, as compared with the activity in SpBABE40 alone and that in the SpBABE40 + L929- $\rho^0$  fusion. The COX activity in the SpBABE40 + GM10611A- $\rho^0$  fusions corresponded to ~50% of the normal mean. No increase of COX activity was detected in any of the other fusions that were tested (data not shown). The partial restoration of COX activity probably is due to incomplete selection of COX-defective

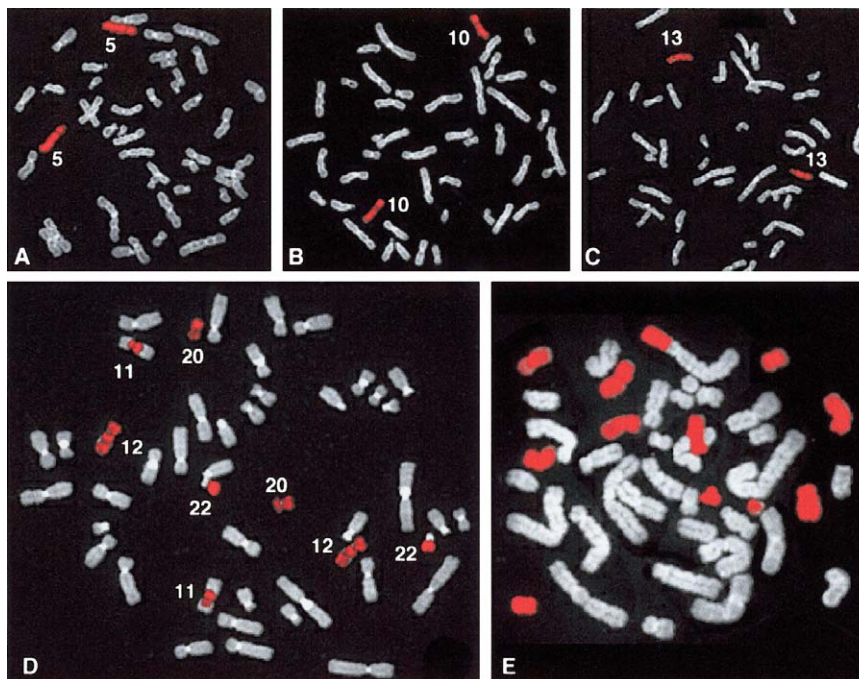
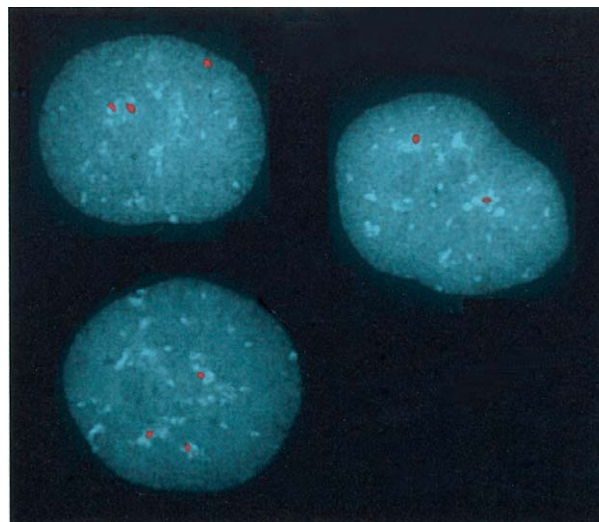

**Figure 4** A–C, Examples of reverse FISH of monochromosomal hybrids GM11714, GM11688, and GM11689, retaining chromosomes 5, 10, and 13, respectively. D, Reverse-FISH characterization of hybrid HY.137J. E, FISH of metaphases from hybrid Y.XY.8F6, using total human DNA as a probe.

parental cells or to a gene-dosage effect, since only one of three copies of the  $LD^{(COX-)}$  gene should be functionally active in fusion cells. The presence of three chromosomes 9 in the GM10611A- $\rho^0$  + SpBABE40 fusion was confirmed by FISH on interphase chromosomes, by using a human chromosome 9-specific alphoid DNA sequence as a probe (fig. 5).

#### *Assignment of the $LD^{(COX-)}$ Locus on Chromosome 9q34, by Linkage Analysis*

For the linkage analysis, we studied nine  $LD^{(COX-)}$  families (fig. 6) that all belonged to a single cell-complementation group (Munaro et al. 1997). Inheritance of the trait was compatible or consistent with an autosomal recessive pattern. Linkage analysis with a series of regularly interspersed chromosome 9-specific microsatellite markers, separated from each other by a genetic distance of ~10 cM, excluded from linkage most of chromosome 9. Primary evidence for linkage was obtained with marker D9S164 on 9q34 (table 2). Further characterization of the region was then performed with a panel of consecutive microsatellite markers arranged in the following order: cen–D9S287–D9S1831–D9S1847–D9S1793–D9S164–D9S1818–D9S1826–tel (see fig. 6). The results of cumulative pairwise analysis using these markers, for nine families, are shown in table 2. MLINK



**Figure 5** FISH of GM10611A- $\rho^0$  + SpBABE40 fusions (chromosome 9-containing  $\rho^0$  hybrid +  $LD^{(COX-)}$  cell line), using the alphoid probe pMR9A, which specifically recognizes the centromeric region of chromosome 9. The presence of the three positive signals in the two nuclei on the left identifies the corresponding cells as GM10611A- $\rho^0$  + SpBABE40 fusion cells, whereas the presence of the two signals in the nucleus on the right identifies the corresponding cell as a non-fused SpBABE40 parental cell.

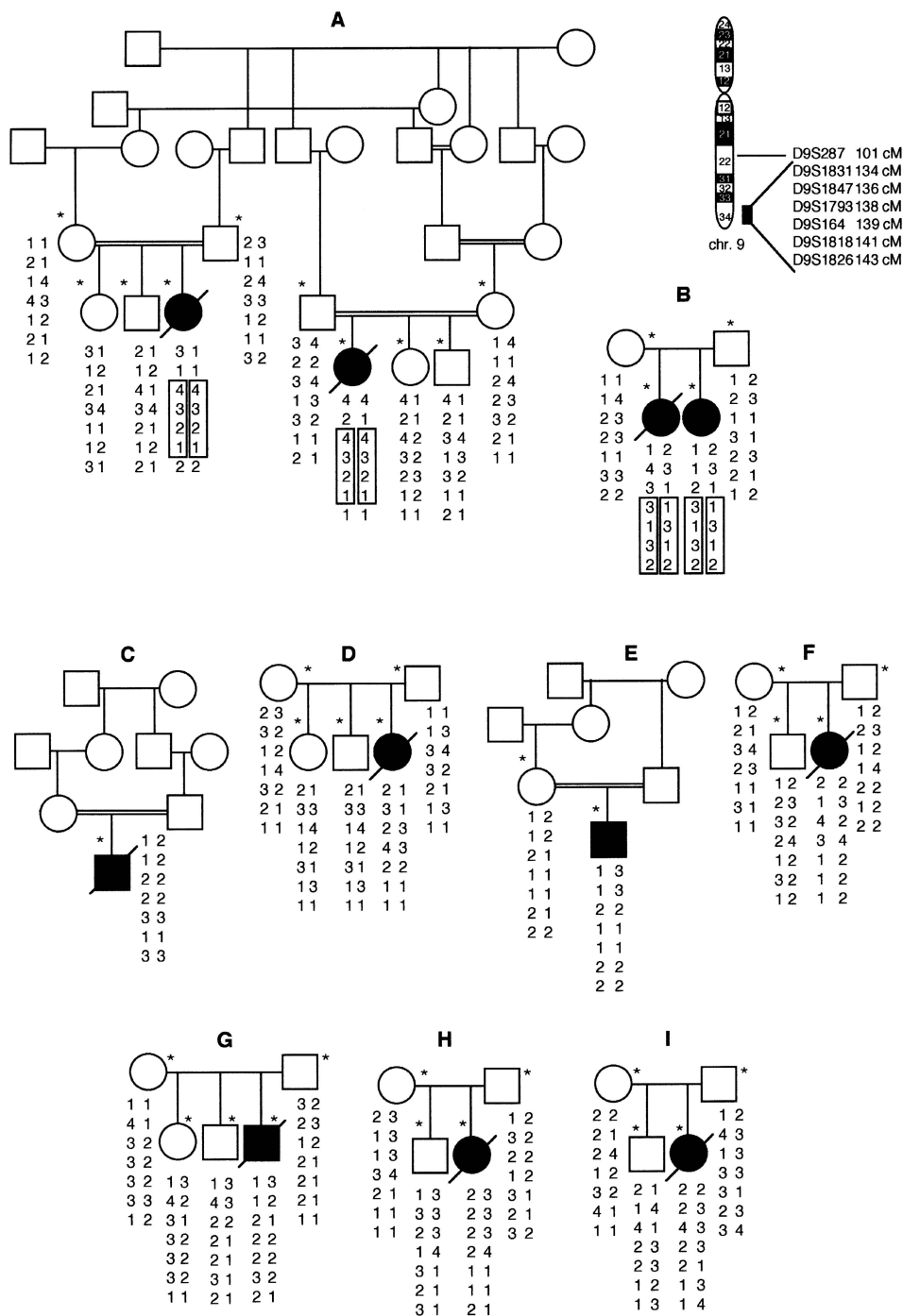

**Figure 6** Family pedigrees. Blackened symbols indicate subjects with LD<sup>(COX<sup>-</sup>)</sup>, and unblackened symbols indicate clinically healthy individuals. Below each symbol is shown the individual haplotype covering a 48-cM region on chromosome 9q22-34. The markers from which the haplotypes were constructed and their genetic distances are shown against a chromosome 9 ideotype. The boxed areas indicate the haploidentical regions in affected individuals in families A and B, which define the critical LD<sup>(COX<sup>-</sup>)</sup> region, between flanking markers D9S1847 and D9S1826.



**Table 2****Pairwise LOD Scores for Linkage of Chromosome 9q Markers with LD<sup>(COX-)</sup>**

MARKER	LOD SCORE AT $\theta =$							$Z_{\max}$	$\theta$
	.00	.01	.05	.1	.2	.3	.4		
D9S287	—∞	—∞	—∞	—∞	—∞	—∞	—∞	...	...
D9S1831	—∞	-3.20	-0.86	-0.16	.15	.13	.05	1.64	.22
D9S1847	—∞	2.23	2.41	2.09	1.29	.63	.22	2.45	.03
D9S1793	4.03	3.90	3.36	2.73	1.61	.77	.25	4.06	.00
D9S164	4.32	4.18	3.60	2.91	1.70	.79	.25	4.32	.00
D9S1818	3.34	3.22	2.76	2.21	1.28	.60	.20	3.34	.00
D9S1826	-3.65	-0.51	.53	.71	.56	.29	.09	.71	.10

analysis of the three consecutive markers D9S1793, D9S164, and D9S1818 gave LOD scores >3 at a recombination fraction ( $\theta$ ) of .00. A maximum LOD score ( $Z_{\max}$ ) of 4.32, calculated by use of the ILINK program, was obtained for marker D9S164, at  $\theta = .00$ . As was expected, the affected members of the three consanguineous families shown in figure 6 were homozygous for consecutive microsatellite markers within the critical region. When the pairwise LOD scores of the closely linked markers in the nine families were tested for heterogeneity (Ott 1991), the  $P$  value in favor of true locus homogeneity was <.00001 ( $\chi^2 = 19.940$ ,  $df = 1$ ).

As shown in figure 6, the haplotype reconstruction demonstrated that in one of the two affected siblings from family B a recombination had occurred in the 2-cM region between the most centromeric marker, D9S1847, and adjacent marker D9S1793, whereas the two siblings were haploidentical from D9S1793 to D9S1826. Likewise, the two affected members of consanguineous family A were haploidentical and homozygous from D9S1818 to D9S1831 but showed different alleles for the most telomeric marker, D9S1826. These findings suggest that the critical region is located between D9S1847 and D9S1826, a distance of ~7 cM.

#### *Analysis of Candidate Genes and Mutation Detection in SURF-1*

The possible candidate genes identified, by MITOP, in the critical region included ENDOG, MPP, and SURF-1. No mutations were found by screening of the cDNA sequences of ENDOG and MPP, in the two index patients from families F and G.

Alignment of the SURF-1 mRNA sequence (GenBank accession number Z35093) with the genomic sequence of cosmid 3H6 (GenBank AC0022107) showed nine exons, which spanned a genomic sequence of 5 kb. SURF-1 exons 1–9 were amplified with intronic primers, and homozygous and heterozygous mutations were detected in all the patients, by sequencing of PCR products (fig. 7 and table 3). We found one splice-site mutation (516+2T→G), at the donor site of intron 5, in one allele

of both patients from family B and a homozygous missense mutation (751C→T), which converts the codon for glutamine 251 into a stop codon (Q251X), in family G. All the other mutations were insertions, deletions, or deletions/insertions resulting in frameshifts. In particular, a frameshift homozygous duplication (37ins17) of a 17-bp sequence (5'-TTGCAGCTGGGGCTGCG-3') was found in exon 1 of both patients from family A. In the same probands, a duplication of a CGCCCCA tandem-repeat element, which normally is present in four copies in intron 1, also was detected. The functional significance of this intronic mutation is uncertain. Most mutations were found in exon 9, where a 2-bp deletion (845delCT) had occurred in three unrelated patients; in one of them, the mutation was homozygous. The other two index patients, in whom mutations were found on both alleles, were compound heterozygotes for frameshift and splice mutations. Only a single heterozygous mutation was found in three additional families.

The sequencing of exons 3–9 also revealed three exonic polymorphisms, which were predicted to cause silent substitutions (data not shown). Analysis of the SURF-1 sequences in the probands' parents was consistent with the heterozygosity of the corresponding mutations (data not shown).

#### **Discussion**

Strategies based on complementation by chromosome transfer allow a genomewide screening of single index cell lines. This is a distinct advantage for disorders, such as LD<sup>(COX-)</sup>, for which the scarcity of informative families and the possibility of genetic heterogeneity can cause linkage analysis to be difficult or not feasible.

In an initial series of experiments, not described in this article, we tried to identify the chromosome containing the complementing gene, by using microcell-mediated chromosome transfer (MMCT) (Killary and Fournier 1995). MMCT allowed us to exclude two chromosomes (2 and 5), but progress was frustratingly slow, because of the unpredictability, laboriousness, and low efficiency of this method, especially when the recipient cells were slowly-growing fibroblasts, as in our study.

These factors prompted us to attempt a new strategy. We first devised a method to eliminate endogenous mtDNA from rodent cells or from rodent/human somatic cell hybrids. This goal was achieved by prolonged exposure to high doses of EtBr, an intercalating agent long used to create rho<sup>0</sup> cell derivatives in different species (King and Attardi 1989). We found that the concentration effective for the production of rodent rho<sup>0</sup> cell lines was 100-fold higher than that used to produce human rho<sup>0</sup> cells, reflecting a remarkable metabolic refractoriness of mtDNA in rodent species.

A prerequisite for the use of whole rodent/human rho<sup>0</sup>

somatic cell hybrids as donors of human chromosomes was the inability of the rodent genome to either complement or induce the enzyme defect. This was proved in a series of experiments in which rodent  $\rho^0$  cell lines were PEG fused with either the LD<sup>(COX<sup>-</sup>)</sup> SpBABE40 cell line or with the control transformant ApBABE40 cell line; the resulting hybrids consistently were COX defective in the former set of experiments, whereas they consistently were COX positive in the latter.

After the EtBr treatment of the somatic cell hybrids, the content of human chromosomes in the  $\rho^0$  hybrid derivatives was verified by FISH. No loss of human genetic material was observed in any of the rodent/human monochromosome hybrids that contained a selectable marker inserted into the human chromosome. However, hybrids lacking human-specific selectable markers, such as the hamster/human hybrids containing different sets of human chromosomes, underwent an apparently random loss of human chromosomes, during the EtBr treatment. Nevertheless, the use of human/rodent monochromosome or of human/rodent polychromosome  $\rho^0$  hybrid derivatives allowed us to conclude that most of

**Table 3****SURF-1 Mutations in LD<sup>(COX<sup>-</sup>)</sup> Patients**

Patient <sup>a</sup>	Mutation(s)	Exon(s)	Type(s) of Mutation
A	37ins17/37ins17	1/1	Frameshift/frameshift
B	516+2T→G/550delAG	5/6	Splice/frameshift
C	868insT/868insT	9/9	Frameshift/frameshift
D	312del10,insAT/...	4/...	Frameshift
E	845delCT/845delCT	9/9	Frameshift/frameshift
F	312del10,insAT/845delCT	4/9	Frameshift/frameshift
G	751C→T/751C→T	7/7	Stop/stop (Q251X)
H	845delCT/...	9/...	Frameshift
I	772delCC/...	8/...	Frameshift

<sup>a</sup> Patient designations are according to the corresponding family designations shown in figure 6.

the human genome does not contain a COX-complementing gene. Primary evidence of COX complementation was obtained from fusions between an LD<sup>(COX<sup>-</sup>)</sup> cell line and a hamster/human hybrid containing human chromosome 9 only. Numerous foci of COX-positive cells were detected, by COX-specific histochemistry, as early as 4 d after fusion. This result was confirmed by

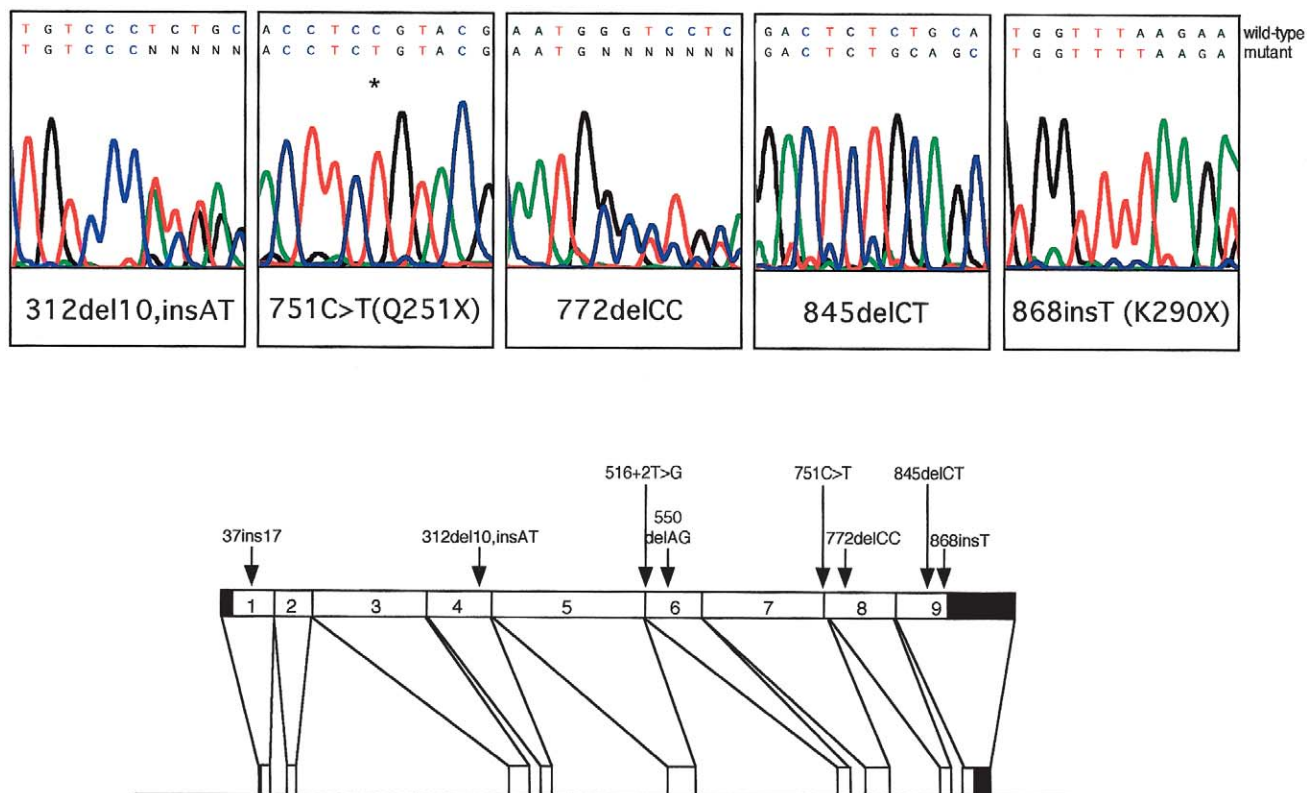

**Figure 7** Mutation map and mutation detection by sequence analysis. *Top*, Examples of five SURF-1 mutations. Mutations 312del10,insAT and 772delCC are heterozygous, whereas the remaining mutations are homozygous. For mutation 772delCC, the reverse complementary strand is displayed. An asterisk (\*) indicates the 751C→T transition. Mutations are numbered by considering the adenine of the first ATG of the SURF-1 cDNA as nt position +1. *Bottom*, Genomic organization of SURF-1 and corresponding cDNA. The locations of the mutations along the cDNA sequence are indicated.

histochemical and biochemical analyses of COX in the heterodikaryon fusion cells.

With the limitations mentioned above, the method presented here appears to offer several advantages over MMCT. First, in the presence of a complementing chromosome, all the heterodikaryon fusion cells, in principle, should show complementation. Thus, starting with an equal number of cocultured parental cells, if we assume that fusions occur randomly, approximately one-third of the fusion cells should show heterodikaryon complementation. These figures are in marked contrast with the extremely low efficiency of MMCT, which typically is reported to result in  $0.5\text{--}5.0 \times 10^{-5}$  "positive" clones that survive after selection (Fournier 1981). Second, the procedure is straightforward, and cell toxicity is low, in contrast with the low efficiency, unpredictability, high cell toxicity, and laboriousness of MMCT. Third, this method allows a very rapid screening of the entire human genome, by using rodent/human hybrids containing different panels of human chromosomes. For instance, the lack of complementation in the cell fusions performed between the LD<sup>(COX<sup>-</sup>)</sup> SpBABE40 cell line and the rho<sup>0</sup> derivatives Y.XY.8F6-ρ<sup>0</sup>, Hy137J-ρ<sup>0</sup>, and Hy166T4-ρ<sup>0</sup> suggested the absence of the responsible gene in as many as 17 different human chromosomes.

Linkage analysis of LD<sup>(COX<sup>-</sup>)</sup> families belonging to the same complementation group confirmed the localization on chromosome 9 and indicated that the critical chromosomal region for LD<sup>(COX<sup>-</sup>)</sup> is flanked by markers D9S1847 and D9S1826, which are located 7 cM apart (see fig. 6). Interestingly, no genes encoding any protein subunit of human COX have been mapped to this region.

Three candidate genes encoding putative mitochondrial proteins (detected with the help of MITOP) were mapped to the critical region. The first is the gene encoding endonuclease G, a protein believed to play a role in mtDNA replication and transcription. The second is a partial-length cDNA (KIAA0123) encoding a polypeptide related to the rat general mitochondrial MPP. MPP is crucial in the processing of mitochondrial protein precursors, by cleaving the N-terminal leader from the mature protein. No mutations in either of these genes were found in two LD<sup>(COX<sup>-</sup>)</sup> patients. The third gene, SURF-1, previously has been shown to be part of a highly conserved "housekeeping" gene cluster, in several mammalian (Lennard et al. 1994) and chicken (Colombo et al. 1992) genomes. Although its precise function has not been determined, the SURF-1 protein product likely is a mitochondrial protein affecting respiratory function, including cytochrome *c* oxidase activity.

The yeast homologue of SURF-1, SHY-1, encodes a mitochondrial inner-membrane protein, and a *shy-1* null mutant is defective in mitochondrial respiration, because

of reduced COX activity (Mashkevich et al. 1997). When analyzed by MITOPROT, the human SURF-1 deduced protein sequence gave a 99.7% probability of being a mitochondrially targeted polypeptide, with a putative cleavage site of the leader peptide between amino acids 44 and 45, according to the "R-2 rule" (Nakai and Kanehisa 1995). The presence of a typical mitochondrial import-signal sequence provides further evidence that SURF-1 encodes a mitochondrial protein. Two potential transmembrane domains are predicted, one on the N terminus of the putative mature protein (amino acids 60–80) and the second on the C terminus (amino acids 271–291), suggesting that, as for the product of SHY-1, the SURF-1 protein is located in the mitochondrial inner membrane.

By sequence analysis of PCR-amplified exons, we found that the probands of all nine families shown in figure 6 harbored mutations of SURF-1. The eight different mutations detected are all deleterious mutations, since they lead to premature stops or frameshifts or since they affect the correct splicing of the gene transcript. Two mutations were found in more than one family. The first is a complex rearrangement consisting of a 10-bp deletion encompassing nts 312–321 plus an insertion of an AT doublet. This mutation, which creates a premature stop codon at nt 314, was found in a compound-heterozygous state. The second mutation was a 2-bp deletion at nts 845–846, producing a premature stop codon at nt 867. This mutation was found in four chromosomes (one homozygous and two compound heterozygous patients). As was expected on the basis of family history and haplotype reconstruction, the patients that belonged to consanguineous families had homozygous mutations (see table 3). Although not proved formally, distant consanguinity between the parents of family G is likely, since they both originated from a small, isolated village in northern Appennines and since the surname of several of their ancestors is the same. This could explain the presence of a homozygous mutation in the affected child from this family.

Six LD<sup>(COX<sup>-</sup>)</sup> patients had mutations on both SURF-1 alleles, whereas only a single mutation was found in three patients. Mutations in intron sequences and other regulatory sequences of SURF-1 or in exons that are difficult to analyze, such as the GC-rich exons 1 and 2, are predicted to account for the missing second mutation in these patients.

The biochemical phenotype of all the patients investigated was homogeneous, since COX activity was reduced to ~10% of the controls' mean, in muscle and fibroblast specimens from all patients. This homogeneity can be explained by the type of the mutation, which predicts the loss of function of the causative protein, SURF-1.

Our results indicate that mutations of SURF-1 are

responsible for at least one predominant complementation group of LD<sup>(COX)</sup>. Although the mouse SURF-1 protein is 75% identical to the human polypeptide, the rodent nuclear background did not rescue the COX phenotype in our fusions, suggesting a highly specific interaction between the product of SURF-1 and the respiratory complex. Biochemical studies focused on the respiratory-chain complexes in both yeast and mammalian systems will shed new light on the molecular pathogenesis of this important mitochondrial disorder.

## Acknowledgments

We thank the patients and their families, whose collaboration and understanding have made this work possible. We gratefully acknowledge Prof. Petra Jacobs (Oregon Health Sciences University, Portland), for the gift of some of the human/rodent hybrids used in this work, and Mr. F. Zanonato and Dr. B. Garavaglia, for helping us contact some of the families. We are indebted to Ms. Barbara Geehan, for revising the manuscript, and to Mr. Franco Carrara, for technical assistance. This work is dedicated to the memory of our friend and colleague Giovanni Salviati, Professor of General Pathology. This study was supported by Fondazione Téléthon–Italy (grants 767 [to M.Z.] and E672 [to M.R.]), Associazione Italiana Ricerca sul Cancro, Ricerca Finalizzata Ministero della Sanità (grant ICS 120.2/RF96.348), Fundación Ramón Areces 1997 (support to J-A.E.), and the European Union Human Capital and Mobility network grant “Mitochondrial Biogenesis in Development and Disease.” K.H. and T.M. were supported by a Deutsches Humangenomprojekt grant from the German Federal Ministry for Education, Research and Technology.

## Electronic-Database Information

Accession numbers and URLs for data in this article are as follows:

- GenBank, <http://www.ncbi.nlm.nih.gov/Web/Genbank> (for the SURF-1 mRNA sequence [Z35093] and the genomic sequence of cosmid 3H6 [AC0022107])  
 MITOP, <http://websvr.mips.biochem.mpg.de/proj/medgen/mitop/> (for identification of mapped ESTs and genes encoding putative mitochondrial proteins)  
 Online Mendelian Inheritance in Man (OMIM), <http://www.ncbi.nlm.nih.gov/Omim> (for Leigh disease [MIM 256000])  
 Unigene, <http://www.ncbi.nlm.nih.gov/UniGene/index-html> (for ESTs)

## References

- Anderson S, Bankier AT, Barrell BG, de Bruijn MHL, Coulson AR, Drouin J, Eperon IC, et al (1981) Sequence and organization of the human mitochondrial genome. *Nature* 290:457–465
- Babcock GT, Wikström M (1992) Oxygen activation and the conservation of energy in cell respiration. *Nature* 356:301–309
- Bibb MJ, Van Etten RA, Wright CT, Walberg MW, Clayton DA (1981) Sequence and gene organization of mouse mitochondrial DNA. *Cell* 26:167–180
- Bourgeron T, Rustin P, Chretien D, Birch-Machin M, Bourgeois M, Viegas-Pequignot E, Munnich A, et al (1995) Mutation of a nuclear succinate dehydrogenase gene results in mitochondrial respiratory chain deficiency. *Nat Genet* 11:144–149
- Breen GA, Miller DL, Holmans PL, Welch G (1986) Mitochondrial DNA of two independent oligomycin-resistant Chinese hamster ovary cell lines contains a single nucleotide change in the ATPase 6 gene. *J Biol Chem* 261:11680–11685
- Brown RM, Brown GK (1996) Complementation analysis of systemic cytochrome oxidase deficiency presenting as Leigh syndrome. *J Inher Metab Dis* 19:752–760
- Claros MG (1995) MitoProt, a Macintosh application for studying mitochondrial proteins. *Comput Appl Biosci* 11:441–447
- Colombo P, Yon J, Garson K, Fried M (1992) Conservation of the organization of five tightly clustered genes over 600 million years of divergent evolution. *Proc Natl Acad Sci USA* 89:6358–6362
- Darley-Usmar VM, Rickwood D, Wilson MT (1987) Mitochondria: a practical approach. IRL Press, Oxford
- Fournier REK (1981) A general high-efficiency procedure for production of microcell hybrids. *Proc Natl Acad Sci USA* 78:6349–6353
- Grossman LI, Lomax MI (1997) Nuclear genes for cytochrome c oxidase. *Biochim Biophys Acta* 1352:174–192
- Jaksch M, Hofmann S, Kleinle S, Liechti-Gallati S, Pongratz DE, Mueller-Hoecker J, Jedele KB, et al (1998) A systematic screen of 10 nuclear and 25 mitochondrial candidate genes in 21 patients with cytochrome c oxidase (COX) deficiency shows tRNAser(UCN) mutations in a subgroup with syndromal encephalopathy. *J Med Genet* 35:895–900
- King M, Attardi G (1989) Human cells lacking mtDNA: repopulation with exogenous mitochondria by complementation. *Science* 246:500–503
- Lathrop GM, Lalouel JM, Julier C, Ott J (1984) Strategies for multilocus linkage analysis in humans. *Proc Natl Acad Sci USA* 81:3443–3446
- Lennard A, Gaston K, Fried M (1994) The Surf-1 and Surf-2 genes and their essential bidirectional promoter elements are conserved between mouse and human. *DNA Cell Biol* 13:1117–1126
- Lichter P, Tang Chang C-J, Call K, Hermanson G, Evans GA, Housman D, Ward DC (1990) High resolution mapping of human chromosomes 11 by in situ hybridization with cosmid clones. *Science* 247:64–69
- Liu P, Siciliano J, Seong D, Craig J, Zhao Y, de Jong PJ, Siciliano MJ (1993) Dual *Alu* PCR primers and conditions for isolation of human chromosome painting probes from hybrid cells. *Cancer Genet Cytogenet* 65:93–99
- Lowry OH, Rosebrough NJ, Farr AL, Randall RJ (1951) Protein measurement with the Folin phenol reagent. *J Biol Chem* 193:265–271
- Mashkevich G, Repetto B, Glerum DM, Jin C, Tzagoloff A

- (1997) SHY1, the yeast homolog of the mammalian SURF-1 gene, encodes a mitochondrial protein required for respiration. *J Biol Chem* 272:14356–14364
- Killary AM, Fournier RE (1995) Microcell fusion. *Methods Enzymol* 254:133–152
- Munaro M, Tiranti V, Sandonà D, Lamantea E, Uziel G, Bisson R, Zeviani M (1997) A single cell complementation class is common to several cases of cytochrome c oxidase-defective Leigh's syndrome. *Hum Mol Genet* 6:221–228
- Nakai K, Kanehisa M (1995) A knowledge base for predicting protein localization sites in eukaryotic cells. *Genomics* 14: 897–911
- Ott J (1991) Heterogeneity due to a mixture of families. In: *Analysis of human genetic linkage*, rev ed. Johns Hopkins University Press, Baltimore, pp 203–216
- Rahman S, Blok RB, Dahl H-H, Danks DM, Kirby DM, Chow CW, Christodoulou J, et al (1996) Leigh syndrome: clinical features and biochemical and DNA abnormalities. *Ann Neurol* 39:343–351
- Robinson BH, Ward J, Goodyer P, Baudet A (1986) Respiratory chain defects in the mitochondria of cultured skin fibroblasts from three patients with lacticacidemia. *J Clin Invest* 77:1422–1427
- Rocchi M, Archidiacono N, Ward DC, Baldini A (1991) A human chromosome 9-specific alphoid DNA repeat spatially resolvable from satellite 3 DNA by fluorescent in situ hybridization. *Genomics* 9:517–523
- Rocchi M, Roncuzzi L, Santamaria R, Archidiacono N, Dente L, Romeo G (1986) Mapping through somatic cell hybrids and cDNA probes of protein C to chromosome 2, factor X to chromosome 13, and alpha1-acid glycoprotein to chromosome 9. *Hum Genet* 74:30–33
- Santorelli FM, Shanske S, Macaya A, DeVivo DC, DiMauro S (1993) The mutation at nt 8993 of mitochondrial DNA is a common cause of Leigh's syndrome. *Ann Neurol* 34: 827–834
- Taanman JW (1997) Human cytochrome c oxidase: structure, function, and deficiency. *J Bioenerg Biomembr* 29:151–163
- Tiranti V, Munaro M, Sandonà D, Lamantea E, Rimoldi M, DiDonato S, Bisson R, et al (1995) Nuclear DNA origin of cytochrome c oxidase deficiency in Leigh's syndrome: genetic evidence based on patient's-derived rho<sup>0</sup> transformants. *Hum Mol Genet* 4:2017–2023
- Zeviani M, Bertagnolio B, Uziel G (1996) Neurological presentations of mitochondrial diseases. *J Inherit Metab Dis* 19: 504–520