



Sharif University of Technology

Scientia Iranica

Transactions B: Mechanical Engineering

[www.sciencedirect.com](http://www.sciencedirect.com)

# Modified wave approach for calculation of natural frequencies and mode shapes in arbitrary non-uniform beams

M. Nikkhah Bahrami<sup>a</sup>, M. Khoshbayani Arani<sup>b,\*</sup>, N. Rasekh Saleh<sup>b,2</sup>

<sup>a</sup> Department of Mechanical Engineering, University of Tehran, Tehran, P.O. Box 14395-515, Iran

<sup>b</sup> Department of Mechanical and Aerospace Engineering, Science and Research Branch, Islamic Azad University, Tehran, P.O. Box 14515-775, Iran

Received 2 November 2010; revised 12 April 2011; accepted 16 July 2011

## KEYWORDS

Wave propagation;  
Reflection;  
Propagation and  
transmission matrices;  
Natural frequencies;  
Mode shapes.

**Abstract** Analytical solutions for the vibration of beams with variable cross-sections are, in general, complex and, in many cases, impossible. On the other hand, approximate methods, such as the weighted residual, Rayleigh–Ritz and finite difference methods, also have their own shortcomings, such as a limited number of natural frequencies and low accuracy. In this paper, using the wave propagation method, the beam is partitioned into several continuous segments, each with a uniform cross-section, for which there exists an exact analytical solution. Waves entering a segment in positive and negative directions are calculated from waves that entered the initial segment. Then, by satisfying the boundary conditions, the characteristic equation is obtained and all natural frequencies are calculated. Also, using the sum of waves at each point that are moving in positive and negative directions, the mode shapes are obtained. To verify this modified method, frequencies whose mode shapes are in a polynomial cross-sectioned beam having an exact analytical solution are compared and thereby proven to be highly accurate. Therefore, this method can also be used to calculate natural frequencies and their mode shapes in beams with variable cross-sections without any analytical solution.

© 2011 Sharif University of Technology. Production and hosting by Elsevier B.V.

Open access under [CC BY-NC-ND license](http://creativecommons.org/licenses/by-nc-nd/3.0/).

## 1. Introduction

The vibration of non-uniform beams has been studied using different approaches, such as analytical, approximate and wave methods.

Cranch and Adler [1] presented closed form solutions in terms of Bessel functions in order to calculate the natural frequencies and mode shapes of beams with four kinds of

rectangular cross-section. Conway and Dubil [2] obtained similar closed-form solutions for truncated cone and wedge beams. Goel [3] obtained closed-form solutions for single and double-tapered truncated beams. Heidebrecht [4], Mabie and Rogers [5] used the second and fourth order polynomials of axial coordinate  $x$  to express the sectional area,  $A(x)$ , and the moment of inertia,  $I(x)$ , respectively. They transformed the partial differential equation of the free vibration of a double tapered beam into an ordinary one, and then solved the last equation to get the natural frequencies. Naguleswaran [6,7] determined the approximate natural frequencies of single and double tapered beams with a direct solution of the mode shape based on the Frobenius method. Abrate [8] found that the equation of motion of a non-uniform beam may be transformed into that of a uniform beam. He, then, calculated the natural frequencies and mode shapes for beams with sectional area  $A(x)$  and moment of inertia  $I(x)$  that had special forms. Laura et al. [9] investigated the natural frequencies of Bernoulli beams with a constant width and bi-linear varying thickness, using three well-known approximate numerical approaches: the Rayleigh–Ritz method, differential quadrature method and finite element method. Datta and Sil [10] employed the reverse procedures of Cranch and Adler to determine the natural frequencies of cantilever beams with constant width and linearly varying depth. Hoffmann and Wertheimer [11]

\* Corresponding author.

E-mail address: [m.khoshbayani@iaukashan.ac.ir](mailto:m.khoshbayani@iaukashan.ac.ir) (M. Khoshbayani Arani).

<sup>1</sup> Present address: Department of Mechanical Engineering, Islamic Azad University, Kashan Branch, Kashan, P.O. Box 87135-433, Iran.

<sup>2</sup> Present address: Department of Mechanical Engineering, Islamic Azad University, East Tehran Branch, Tehran, P.O. Box 33955-163, Iran.

1026-3098 © 2011 Sharif University of Technology. Production and hosting by Elsevier B.V. Open access under [CC BY-NC-ND license](http://creativecommons.org/licenses/by-nc-nd/3.0/).

Peer review under responsibility of Sharif University of Technology.

doi:10.1016/j.scient.2011.08.004



Production and hosting by Elsevier

ELSEVIER

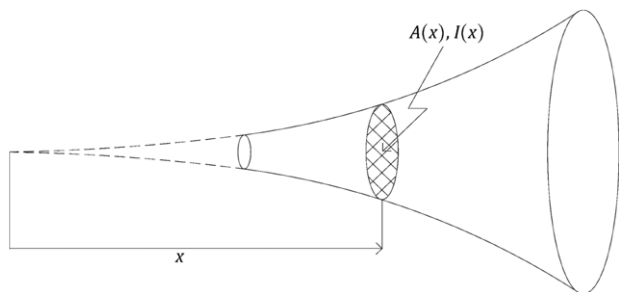

Figure 1: A non-uniform beam.

presented a simple formula for determining the fundamental frequency of a tapered cantilever beam. Mabie and Rogers [12] studied the transverse vibration of single-tapered clamped-hinged beams. Baberjee and William [13] gave the solutions to obtain the exact dynamic stiffness matrices of some non-uniform beams. Nikkhah-Bahrami [14], Loghmani [15] and Lee et al. [16] used a wave approach to analyze the non-uniform rod and beam whose analytical solution is available, such as a polynomial or exponential cross-section. In this paper, the above-mentioned wave propagation method is applied by the authors to present a modified wave propagation method for calculation of frequencies and mode shapes of a beam with an arbitrary variable cross-section for which no analytical solution is available. Using a modified wave propagation method, a typical beam is partitioned into several continuous segments with a constant cross-section, each having an analytical solution. Waves at the entrance of an arbitrary continuous segment in positive and negative directions are propagated and transmitted to another segment, which could be expressed in terms of the waves at the initial segment. Then, by satisfying the boundary conditions, a characteristic equation is obtained and the natural frequencies are calculated. Also, by adding waves in positive and negative directions at each point, the shape modes are obtained.

## 2. Methodology for the calculation of natural frequencies and mode shapes of non-uniform beams

For illustration and validity of the method developed here, a beam with an arbitrary variable cross-section is considered (Figure 1).

The beam, with an arbitrary variable cross-section, is partitioned into several continuous segments with constant cross-sections, each having an analytical solution (Figure 2). If one wants to save time on calculations, and obtain more accuracy with a lesser quantity of partitions, it would be possible to divide the beam into partitions proportional to the slope of varying cross-sections, as indicated in Figure 2. But of course in this paper, the beam is partitioned with equal lengths for simplicity. In this section, at first, a generalized approach based on the reflection, transmission and propagation of waves for the analysis of a uniform beam is reviewed and then the modified wave propagation method is presented.

### 2.1. Wave description of vibration for a uniform beam

The governing partial differential equation for free vibration of the uniform beam is as follows [16]:

$$EI \frac{\partial^4 w(x, t)}{\partial x^4} + \rho A \frac{\partial^2 w(x, t)}{\partial t^2} = 0, \quad (1)$$

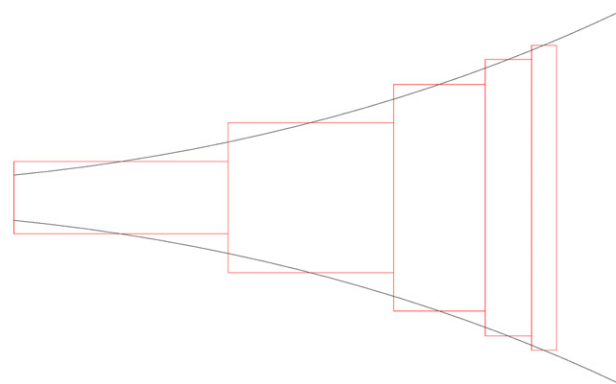

Figure 2: Division of non-uniform beam proportional to slope of varying cross-section.

where  $x$  is the axial coordinate,  $w$  is the transverse deflection,  $E$  is Young's modulus,  $\rho$  is the mass density of material,  $A$  is the cross-sectional area of the uniform beam,  $I$  is the moment of inertia of  $A$ , and  $t$  is the time.

Solution of Eq. (1) is as follows:

$$w(x, t) = f(ct - x) + g(x + ct), \quad (2)$$

where  $c = \sqrt{\frac{EI}{\rho A}}$  and  $f(ct - x)$  and  $g(x + ct)$  represent, respectively, positive and negative directions of the moving waves with velocity  $c$ .

We can rewrite the solution for Eq. (1) as follows:

$$w(x, t) = W(x)F(t), \quad (3)$$

$$w(x, t) = e^{\lambda x + i\omega t}, \quad (4)$$

$$W(x) = e^{\lambda x}, \quad (5)$$

$$F(t) = e^{i\omega t}. \quad (6)$$

By substituting Eq. (3) into Eq. (1), we have:

$$EI \frac{d^4 W(x)}{dx^4} F(t) + \rho A W(x) \frac{d^2 F(t)}{dt^2} = 0. \quad (7)$$

Using Eqs. (5) and (6), we have:

$$EI \lambda^4 W(x) F(t) - \rho A \omega^2 W(x) F(t) = 0, \quad (8)$$

then:

$$EI \lambda^4 = \rho A \omega^2. \quad (9)$$

By solving Eq. (9), we have:

$$\lambda_1 = k, \quad \lambda_2 = -k, \quad \lambda_3 = ik, \quad \lambda_4 = -ik,$$

where:

$$k = \sqrt[4]{\frac{\rho A \omega^2}{EI}}. \quad (10)$$

Then, we can write Eq. (10) as follows:

$$w(x, t) = (C_1 e^{-ikx} + C_2 e^{ikx} + C_3 e^{-kx} + C_4 e^{kx}) e^{i\omega t}, \quad (11)$$

where:

$$W(x) = (C_{1w} e^{-ikx} + C_{2w} e^{ikx} + C_{3w} e^{-kx} + C_{4w} e^{kx}), \quad (12)$$

$$F(t) = e^{i\omega t}. \quad (13)$$

$C_1 - C_4$  are constants and  $k$  is wave number.

The vibration of a beam could be considered as a wave that is propagating left and right in the beam. The form of the wave

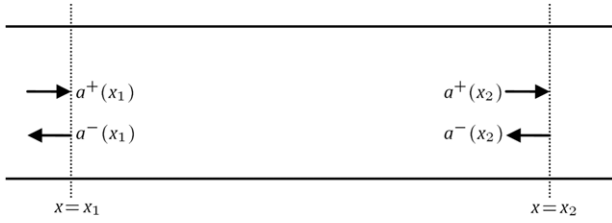

Figure 3: Positive and negative waves.

depends on the nature of the governing differential equation of the structure (Figure 3).

In the beam, the motion in the waveguide is described by a partial differential equation of order 4. The solution (Eq. (12)) gives 2 pairs of positive and negative going wave components as follows:

$$\begin{aligned} a_1^+ &= C_1 e^{-ikx}, & a_{II}^+ &= C_2 e^{-kx}, \\ a_1^- &= C_3 e^{ikx}, & a_{II}^- &= C_4 e^{kx}, \end{aligned} \quad (14)$$

so that  $a^+$  and  $a^-$  are  $2 \times 1$  vectors.  $a^+ = [a_1^+ \ a_{II}^+]$  and  $a^- = [a_1^- \ a_{II}^-]$ . The relationship between positive and negative waves at  $x_1, x_2$  is:

$$\begin{Bmatrix} a^+(x_2) \\ a^-(x_2) \end{Bmatrix} = \begin{bmatrix} F^+ & 0 \\ 0 & F^- \end{bmatrix} \begin{Bmatrix} a^+(x_1) \\ a^-(x_1) \end{Bmatrix}, \quad (15)$$

where  $F^+, F^-$  are propagation matrices as below:

$$F^+ = F^- = \begin{bmatrix} e^{-ikL} & 0 \\ 0 & e^{kL} \end{bmatrix}, \quad (16)$$

where  $x_2 - x_1 = L$  and  $k = \sqrt{\frac{\rho A \omega^2}{EI}}$  is the wave number. The relationship between the state vector in the physical domain and the state vector in the wave domain is obtained as follows [16]:

$$\begin{Bmatrix} w \\ f \end{Bmatrix} = \begin{bmatrix} \psi^+ & \psi^- \\ \phi^+ & \phi^- \end{bmatrix} \begin{Bmatrix} a^+ \\ a^- \end{Bmatrix}, \quad (17)$$

where  $w$  and  $f$  are a  $2 \times 1$  vector that denotes displacements and internal forces, respectively, and  $\psi$  and  $\phi$  are  $2 \times 2$  displacement and internal force matrices, as follows:

$$w = \begin{bmatrix} w & \frac{\partial w}{\partial x} \end{bmatrix}, \quad (18)$$

$$F = [Q \ M], \quad (19)$$

$$\psi^+ = \begin{bmatrix} 1 & 1 \\ -ik & -k \end{bmatrix}, \quad (20)$$

$$\psi^- = \begin{bmatrix} 1 & 1 \\ ik & k \end{bmatrix}, \quad (21)$$

$$\phi^+ = EI \begin{bmatrix} -ik^3 & k^3 \\ -k^2 & k^2 \end{bmatrix}, \quad (22)$$

$$\phi^- = EI \begin{bmatrix} ik^3 & -k^3 \\ -k^2 & k^2 \end{bmatrix}. \quad (23)$$

When the waves encounter boundary conditions or discontinuities, they are transmitted and some of them are reflected. One type of discontinuity is a step; in other words, a sudden change in the cross-section, which is shown in Figure 4.

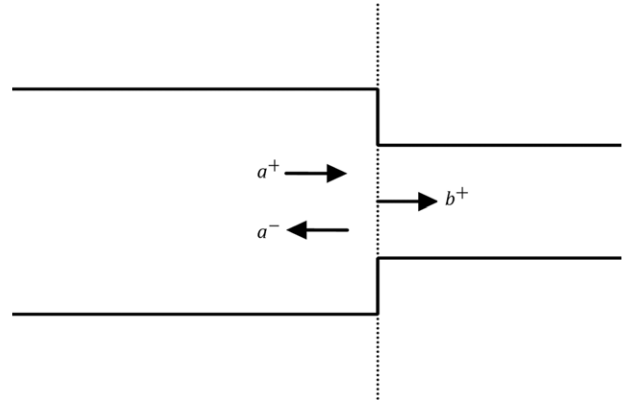

Figure 4: Reflection and transmission of waves in step beam.

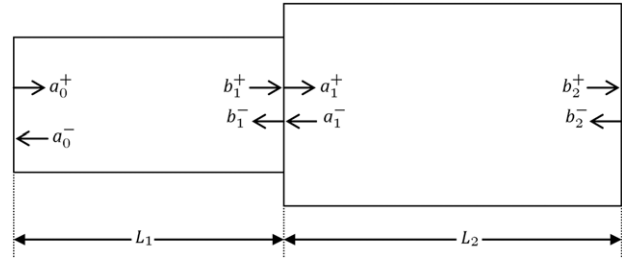

Figure 5: Reflection and transmission of waves in stepped beam.

Relations between propagated, reflected and transmitted waves are defined as follows:

$$a^- = Ra^+, \quad (24)$$

$$b^+ = Ta^+, \quad (25)$$

in which  $R$  and  $T$  are reflection and transmission matrices. Using Eqs. (24) and (25) and equations of equilibrium and continuity at the step, then the transmission and reflection matrices for the step shall be as follows:

$$R = -[\phi_b^+(\psi_b^+)^{-1}\psi_a^- + \phi_a^+]^{-1}[-\phi_b^+(\psi_b^+)^{-1}\psi_a^+ + \phi_a^+], \quad (26)$$

$$T = [\phi_a^-(\psi_a^-)^{-1}\psi_b^+ - \phi_b^+]^{-1}[\phi_a^-(\psi_a^-)^{-1}\psi_a^+ - \phi_a^+]. \quad (27)$$

If the discontinuity represents a boundary, so that there are no transmitted waves, the reflection matrix at the boundary can be obtained from the reflection matrix by setting the terms with the subscript to be zero.

### 3. Modified wave propagation method

The beam with a step and its boundaries (Figure 5) is considered, and the relationships between propagated, reflected and transmitted waves in positive and negative directions (step number 1) are defined as follows:

$$a_1^+ = T_{f1}b_1^+ + R_{b1}a_1^-, \quad (28)$$

$$b_1^- = R_{f1}b_1^+ + T_{b1}a_1^-, \quad (29)$$

in which  $T_{f1}$  and  $T_{b1}$  are transmission functions in forward and backward directions and  $R_{f1}$  and  $R_{b1}$  are reflection functions in forward and backward directions at step number 1.

Then, using Eqs. (28) and (29), positive and negative waves at the right side in terms of the left side of the step are obtained:

$$a_1^+ = T_{f1} \cdot b_1^+ + R_{b1} T_{b1}^{-1} (b_1^- - R_{f1} b_1^+), \quad (30)$$

$$a_1^- = T_{b1}^{-1} (b_1^- - R_{f1} b_1^+). \quad (31)$$

Waves propagate through the length of the segment. Relationships between positive and negative waves at the right side of the segment in terms of waves at its left side are defined as follows:

$$b_1^+ = F^+(L_1) \cdot a_0^+, \quad (32)$$

$$b_1^- = (F^-(L_1))^{-1} \cdot a_0^-. \quad (33)$$

Substituting Eqs. (32) and (33) into Eqs. (30) and (31), one would get:

$$a_1^+ = (T_{f1} - R_{b1} T_{b1}^{-1} R_{f1}) F^+(L_1) a_0^+ + (R_{b1} T_{b1}^{-1}) (F^-(L_1))^{-1} a_0^-, \quad (34)$$

$$a_1^- = (-T_{b1}^{-1} R_{f1} F_{(L_1)}^+) a_0^+ + (T_{b1}^{-1} (F_{(L_1)}^-)^{-1}) a_0^-. \quad (35)$$

One can thus write Eqs. (34) and (35) as follows:

$$a_1^+ = \mu_1 \cdot a_0^+ + \lambda_1 \cdot a_0^-, \quad (36)$$

$$a_1^- = \eta_1 \cdot a_0^+ + \beta_1 \cdot a_0^-, \quad (37)$$

where:

$$\mu_1 = [T_{f1} - R_{b1} T_{b1}^{-1} R_{f1}] F_{(L_1)}^+, \quad (38)$$

$$\lambda_1 = (R_{b1} T_{b1}^{-1}) (F_{(L_1)}^-)^{-1}, \quad (39)$$

$$\eta_1 = (-T_{b1}^{-1} R_{f1} F_{(L_1)}^+), \quad (40)$$

$$\beta_1 = T_{b1}^{-1} (F_{(L_1)}^-)^{-1}. \quad (41)$$

Eqs. (36) and (37) can be written in the matrix form:

$$\begin{bmatrix} a_1^+ \\ a_1^- \end{bmatrix} = \begin{bmatrix} \mu_1 & \lambda_1 \\ \eta_1 & \beta_1 \end{bmatrix} \begin{bmatrix} a_0^+ \\ a_0^- \end{bmatrix}. \quad (42)$$

Positive and negative waves at the right of step number 1 are propagated through the length of the second segment and are given by the following relationships:

$$b_2^+ = F^+(L_2) \cdot a_1^+, \quad (43)$$

$$b_2^- = (F^-(L_2))^{-1} \cdot a_1^-, \quad (44)$$

in which  $L_2$  is the length of the second segment. Substituting Eq. (42) into Eqs. (43) and (44), one would get:

$$b_2^+ = F_{(L_1)}^+ \cdot \left[ T_{f1} F_{(L_1)}^+ a_0^+ + R_{b1} T_{b1}^{-1} \left( (F_{(L_1)}^-)^{-1} a_0^- - R_{f1} F_{(L_1)}^+ a_0^+ \right) \right], \quad (45)$$

$$b_2^- = (F_{(L_1)}^-)^{-1} \cdot T_{b1}^{-1} \left( (F_{(L_1)}^-)^{-1} a_0^- - R_{f1} F_{(L_1)}^+ a_0^+ \right). \quad (46)$$

One can write Eqs. (45) and (46) in the form of Eqs. (47) and (48):

$$b_2^+ = \mu \cdot a_0^+ + \lambda \cdot a_0^-, \quad (47)$$

$$b_2^- = \eta \cdot a_0^+ + \beta \cdot a_0^-, \quad (48)$$

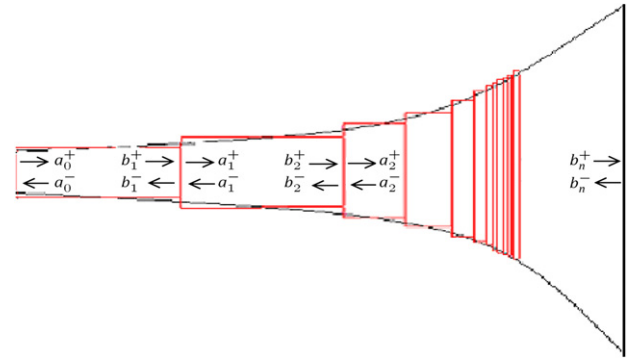

Figure 6: Non-uniform beam with an arbitrary variable cross-section.

where:

$$\mu = F_{(L_1+L_2)}^+ \cdot (T_{f1} - R_{b1} T_{b1}^{-1} R_{f1}), \quad (49)$$

$$\lambda = F_{(L_2)}^+ (F_{(L_1)}^-)^{-1} \cdot R_{b1} T_{b1}^{-1}, \quad (50)$$

$$\eta = -F_{(L_1)}^+ (F_{(L_2)}^-)^{-1} \cdot R_{f1} T_{b1}^{-1}, \quad (51)$$

$$\beta = - (F_{(L_1)}^-)^{-1} (F_{(L_2)}^-)^{-1} \cdot T_{b1}^{-1}. \quad (52)$$

One can write Eqs. (47) and (48) in the matrix form as follows:

$$\begin{bmatrix} b_2^+ \\ b_2^- \end{bmatrix} = \begin{bmatrix} \mu & \lambda \\ \eta & \beta \end{bmatrix} \begin{bmatrix} a_0^+ \\ a_0^- \end{bmatrix}. \quad (53)$$

Satisfying the boundary conditions will yield the characteristic equation for wave numbers by which the wave numbers can be found.

By performing the above mentioned methodology, for all segments in a non-uniform one-dimensional waveguide with an arbitrary variable in the cross-section (Figure 6), the positive and negative traveling waves under the right boundary condition are obtained in terms of waves under the left boundary condition.

Similarly, by adapting Eq. (53) for step number  $n$ , one would get:

$$a_n^+ = [T_{fn} - R_{bn} T_{bn}^{-1} R_{fn}] F_{(L_n)}^+ a_{n-1}^+ + (R_{bn} T_{bn}^{-1}) (F_{(L_n)}^-)^{-1} a_{n-1}^-, \quad (54)$$

$$a_n^- = (-T_{bn}^{-1} R_{fn} F_{(L_n)}^+) a_{n-1}^+ + (T_{bn}^{-1} (F_{(L_n)}^-)^{-1}) a_{n-1}^-. \quad (55)$$

One can write Eqs. (54) and (55) as follows:

$$a_n^+ = \mu_n \cdot a_{n-1}^+ + \lambda_n \cdot a_{n-1}^-, \quad (56)$$

$$a_n^- = \eta_n \cdot a_{n-1}^+ + \beta_n \cdot a_{n-1}^-. \quad (57)$$

Eqs. (56) and (57) can be written in the matrix form as follows:

$$\begin{bmatrix} a_n^+ \\ a_n^- \end{bmatrix} = \begin{bmatrix} \mu_n & \lambda_n \\ \eta_n & \beta_n \end{bmatrix} \begin{bmatrix} a_{n-1}^+ \\ a_{n-1}^- \end{bmatrix}, \quad (58)$$

where:

$$\mu_n = [T_{fn} - R_{bn} T_{bn}^{-1} R_{fn}] F_{(L_n)}^+, \quad (59)$$

$$\lambda_n = (R_{bn} T_{bn}^{-1}) (F_{(L_n)}^-)^{-1}, \quad (60)$$

$$\eta_n = -T_{bn}^{-1} R_{fn} F_{(L_n)}^+, \quad (61)$$

$$\beta_n = T_{bn}^{-1} (F_{(L_n)}^-)^{-1} e^{ikL_n}. \quad (62)$$

Then, one can obtain entrance waves in the “*n*th” segment in terms of waves under the left boundary condition as follows:

$$\begin{bmatrix} a_n^+ \\ a_n^- \end{bmatrix} = \begin{bmatrix} \mu_n & \lambda_n \\ \eta_n & \beta_n \end{bmatrix} \begin{bmatrix} \mu_{n-1} & \lambda_{n-1} \\ \eta_{n-1} & \beta_{n-1} \end{bmatrix} \times \begin{bmatrix} \mu_{n-2} & \lambda_{n-2} \\ \eta_{n-2} & \beta_{n-2} \end{bmatrix} \dots \begin{bmatrix} \mu_1 & \lambda_1 \\ \eta_1 & \beta_1 \end{bmatrix} \begin{bmatrix} a_0^+ \\ a_0^- \end{bmatrix}. \quad (63)$$

One can write Eq. (63) as follows:

$$\begin{bmatrix} a_n^+ \\ a_n^- \end{bmatrix} = \begin{bmatrix} \mu_{\text{total}} & \lambda_{\text{total}} \\ \eta_{\text{total}} & \beta_{\text{total}} \end{bmatrix} \begin{bmatrix} a_0^+ \\ a_0^- \end{bmatrix}, \quad (64)$$

where:

$$\begin{bmatrix} \mu_{\text{total}} & \lambda_{\text{total}} \\ \eta_{\text{total}} & \beta_{\text{total}} \end{bmatrix} = \begin{bmatrix} \mu_n & \lambda_n \\ \eta_n & \beta_n \end{bmatrix} \begin{bmatrix} \mu_{n-1} & \lambda_{n-1} \\ \eta_{n-1} & \beta_{n-1} \end{bmatrix} \times \begin{bmatrix} \mu_{n-2} & \lambda_{n-2} \\ \eta_{n-2} & \beta_{n-2} \end{bmatrix} \dots \begin{bmatrix} \mu_1 & \lambda_1 \\ \eta_1 & \beta_1 \end{bmatrix}.$$

Relations between propagated waves and entrance waves in the “*n*th” segment are:

$$b_n^+ = F_{(L_n)}^+ \cdot a_n^+, \quad (65)$$

$$b_n^- = \left(F_{(L_n)}^-\right)^{-1} \cdot a_n^-, \quad (66)$$

in which  $L_n$  is the length of segment number  $n$ .

Then, one can obtain positive and negative waves under the right boundary condition in terms of waves under the left boundary condition.

Satisfying the boundary conditions will yield the characteristic equation for wave numbers by which the wave numbers can be found. Thereby, using the relationship between the natural frequencies and wave number for the beam (Eq. (10)), the natural frequencies are calculated. On the other hand, by substituting each natural frequency into waves in positive and negative directions, the transverse deflection, slope, moment of bending and shear force at step number  $n$  are calculated as follows:

$$y_n = a_{ln}^+ + a_{ln}^- + a_{ln}^+ + a_{ln}^-, \quad (67)$$

$$\theta_n = \frac{dy_n}{dx} = -ika_{ln}^+ + ika_{ln}^- - ika_{ln}^+ + ika_{ln}^-, \quad (68)$$

$$M_n = EI \frac{d^2y_n}{dx^2} = EI \left(-k^2 a_{ln}^+ - k^2 a_{ln}^- - k^2 a_{ln}^+ - k^2 a_{ln}^-\right), \quad (69)$$

$$Q_n = EI \frac{d^3y_n}{dx^3} = EI \left(ik^3 a_{ln}^+ - ik^3 a_{ln}^- + ik^3 a_{ln}^+ - ik^3 a_{ln}^-\right). \quad (70)$$

By choosing an arbitrary value for  $a_0^+$  into Eqs. (67)–(70) and satisfying the boundary conditions, the mode shapes ( $y_n$ ) are calculated. Consequently, it becomes easy to calculate the mode shapes.

#### 4. Analytical method

The governing partial differential equation for the free vibration of non-uniform beam is as follows:

$$\frac{\partial^2}{\partial x^2} \left[ EI(x) \frac{\partial^2 w(x,t)}{\partial x^2} \right] + \rho A(x) \frac{\partial^2 w(x,t)}{\partial t^2} = 0, \quad (71)$$

where  $x$  is the axial coordinate,  $w$  is the transverse deflection,  $E$  is Young’s modulus,  $\rho$  is the mass density of material,  $A(x)$  is the cross-sectional area of the beam,  $I(x)$  is the moment of inertia of  $A(x)$ , and  $t$  is the time. If the values of  $A(x)$  and  $I(x)$  take the following form:

$$\rho A(\xi) = \rho A_1 \xi^n, \quad EI(x) = EI_1 (\xi)^{n+2}, \quad \xi = \frac{x}{L_1}, \quad (72)$$

then, the solution of the governing partial differential equation for free vibration of this beam (Eq. (71)) is given by [17]:

$$W(\xi) = L^{-n/2} \xi^{-n/2} [c_1 J_n(z) + c_2 Y_n(z) + c_3 I_n(z) + c_4 K_n(z)]. \quad (73)$$

$L_1$  is the length of the beam extending from the sharp end (the origin of the axial coordinate  $x$ ) to the large end. Also, respectively,  $A_1$  and  $I_1$  are the cross-sectional area and the moment of inertia,  $A(x)$ , at the large end of the beam, while  $n$  is a parameter defining variations of  $A(x)$  and  $I(x)$  along the length of the beam.  $J_n$  and  $Y_n$  are  $n$ th order Bessel functions of the first and second kinds, respectively,  $c_1$ – $c_4$  are constants determined by the boundary conditions, and finally:

$$z = 2k \left( \frac{x}{L_1} \right)^{1/2}, \quad (74)$$

$$k^4 = \omega^2 L_1^4 \left( \frac{\rho A_1}{EI_1} \right) \quad (75)$$

where  $W$  is the amplitude of deflection,  $w(x, t)$ , and represents the mode shape of the beam in free vibration. Then, by satisfying the boundary conditions in Eq. (73) and solving them, the characteristic equation is obtained and all natural frequencies are calculated. Finally, using Eq. (73), the mode shapes are obtained.

#### 5. Results

Results of the first five non-dimensional natural frequencies ( $k_n L$ ) for the transverse vibration of non-uniform beams ( $n = 1$ ,  $L = 1$  m,  $L_1 = 2$  m) under Free-Clamped (F-C) boundary conditions are, respectively, found to be 3.2015, 8.0134, 13.409, 18.770 and 24.133 from the analytical (exact) method (Eq. (73)), the modified wave propagation method with few numbers of partitions (a novel method in this paper) and F.E.M.

Also, results of the first five mode shapes for the first five non-dimensional natural frequencies ( $k_n L$ ) for the transverse vibration of non-uniform beams  $n = 1$ ,  $L = 1$  m and  $L_1 = 2$  m under free-clamped boundary conditions are given in Figures 7–11. The mode shapes of the modified wave propagation method (Eq. (67)), the analytical method (Eq. (73)) and F.E.M. are given. The above-mentioned figures show that the accuracy of the modified wave propagation method (the method introduced in this paper) is very high.

#### 6. Conclusion

The modified wave propagation method was used to calculate the natural frequencies and mode shapes for the lateral vibration of a stepped beam, with the intention of obtaining the natural frequencies and mode shapes for non-uniform beams by partitioning them into a collection of continuous segments with constant cross-sections.

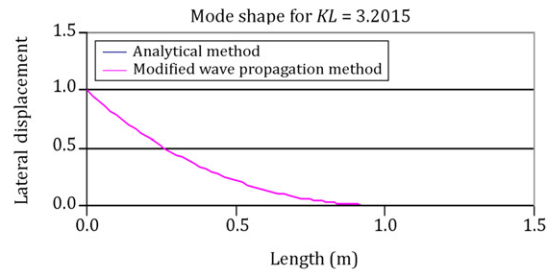
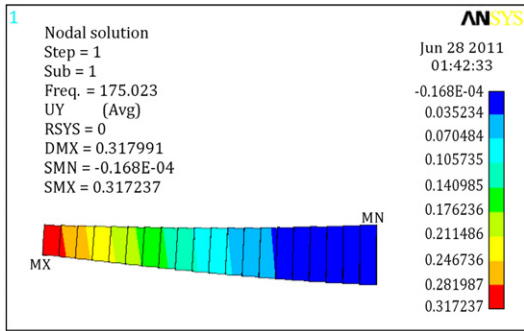

Figure 7: Mode shape of non-uniform beam for  $KL = 3.2015$  (Free-Clamp).

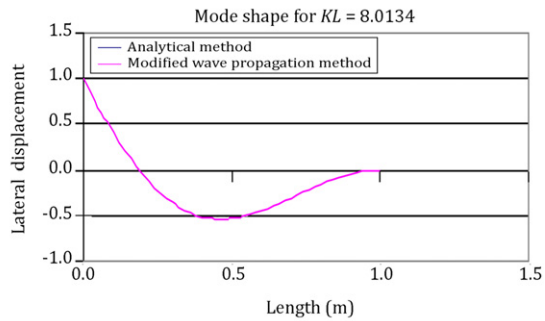
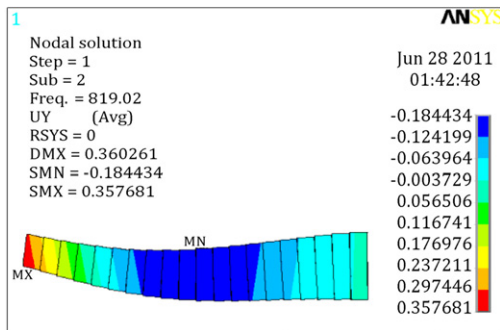

Figure 8: Mode shape of non-uniform beam for  $KL = 8.0134$  (Free-Clamp).

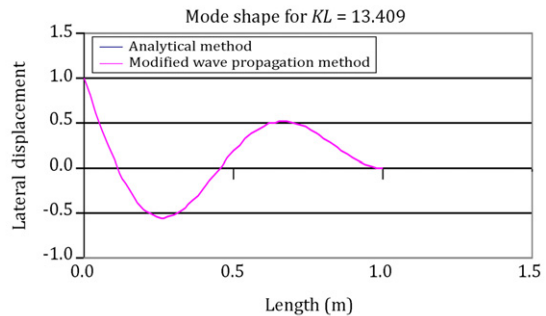
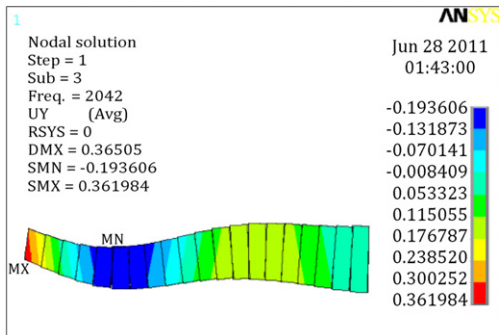

Figure 9: Mode shape of non-uniform beam for  $KL = 13.409$  (Free-Clamp).

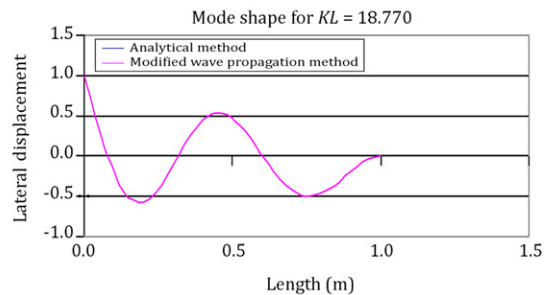
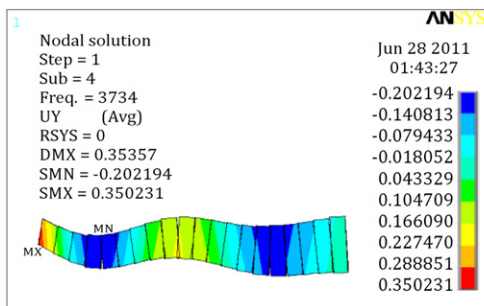

Figure 10: Mode shape of non-uniform beam for  $KL = 18.77$  (Free-Clamp).

Waves in positive and negative directions at the end of each segment are expressed in terms of the waves at

the entrance of an initial segment. Subsequently, dimensions of the transmission matrix remain constant if the number

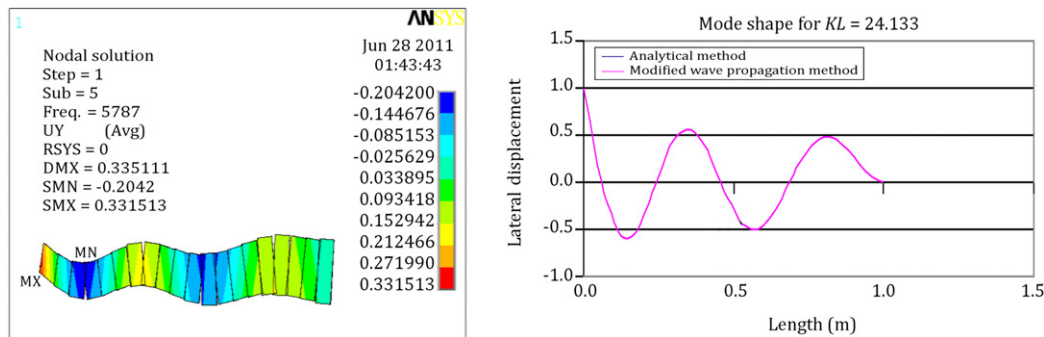

Figure 11: Mode shape of non-uniform beam for  $KL = 24.133$  (Free-Clamp).

of segments is increased, while in general, in the wave propagation method, dimensions of the transmission matrix increase upon increasing the number of segments; this makes calculation of the characteristic equation and mode shape very simple. Besides, the method presented in this paper has the benefit of calculating all natural frequencies and mode shapes, while approximate methods, such as the weighted residual, Rayleigh–Ritz and finite difference methods, have their own shortcomings, such as having only a limited number of natural frequencies. Also, since each segment has an exact analytical solution, in contrast to other approximate methods, much higher accuracy is obtained even with only a few numbers of partitions.

## References

- [1] Cranch, E.T. and Adler, A.A. "Bending vibrations of variable section beams", *Journal of Applied Mechanics*, 23, pp. 103–108 (1956).
- [2] Conway, H.D. and Dubil, J. "Vibration frequencies of truncated cone and wedge beams", *Journal of Applied Mechanics, American Society of Mechanical Engineers*, 32(4), pp. 932–934 (1965).
- [3] Goel, R.P. "Transverse vibrations of tapered beams", *Journal of Sound and Vibration*, 47, pp. 1–7 (1976).
- [4] Heidebrecht, A.C. "Vibration of non-uniform simply supported beams", *Journal of the Engineering Mechanics Division, Proceedings of the American Society of Civil Engineers*, 93, pp. 1–15 (1967).
- [5] Mabic, H.H. and Rogers, C.B. "Transverse vibrations of tapered cantilever beams with end support", *Journal of the Acoustical Society of America*, 44, pp. 1739–1741 (1968).
- [6] Naguleswaran, S. "Vibration of an Euler–Bernoulli beam of constant depth and with linearly varying breadth", *Journal of Sound and Vibration*, 153(3), pp. 509–522 (1994).
- [7] Naguleswaran, S. "A direct solution for the transverse vibration of Euler–Bernoulli wedge and cone beams", *Journal of Sound and Vibration*, 172(3), pp. 289–304 (1994).
- [8] Abrate, S. "Vibration of non-uniform rods and beams", *Journal of Sound and Vibration*, pp. 703–716 (1995).
- [9] Laura, P.A.A., Gutierrez, R.H. and Rossi, R.E. "Free vibration of beams of bi-linearly varying thickness", *Ocean Engineering*, 23(1), pp. 1–6 (1996).
- [10] Datta, A.K. and Sil, S.N. "An analysis of free un-damped vibration of beams of varying cross-section", *Journal of Computers and Structures*, 59(3), pp. 479–483 (1996).
- [11] Hoffmann, J.A. and Wertheimer, T. "Cantilever beam vibration", *Journal of Sound and Vibration*, 229(5), pp. 1269–1276 (2000).
- [12] Mabic, H.H. and Rogers, C.B. "Transverse vibrations of double-tapered cantilever beams with end support and with end mass", *Journal of the Acoustical Society of America*, 55, pp. 986–991 (1974).
- [13] Baberjee, J.R. and Williams, F.W. "Exact Euler–Bernoulli dynamic stiffness matrix for a range of tapered beams", *International Journal for Numerical Methods in Engineering*, 21, pp. 2289–2302 (1985).
- [14] Nikkhah-Bahrami, M. and Loghmani, M. "Wave propagation in exponentially varying cross-section rods and vibration analysis", *International Conference of Numerical Analysis and Applied Mathematics, AIP Conference Proceedings*, 1048, pp. 798–801 (2008).
- [15] Loghmani, M. "Vibration analysis from wave standpoint in dispersive mediums", M.S. Thesis in Mechanical Engineering, University of Tehran, Iran (Sept. 2008).
- [16] Lee, S.-K., et al. "Wave propagation, reflection and transmission in non-uniform one-dimensional waveguides", *Journal of Sound and Vibration*, 304, pp. 31–49 (2007).
- [17] Watson, G.N., *A Treatise on the Theory of Bessel Functions*, Cambridge University Press, Cambridge (1995).

**Mansour Nikkhah Bahrami** received his B.S. degree in Civil Engineering from University of Texas, Austin, Texas, USA, 1963, his M.S. in Civil Engineering from University of Texas, Austin, Texas, USA, 1965, his Ph.D. in Engineering Mechanics and Computational Mechanics from University of Texas, Austin, Texas, USA, 1969.

**Mohsen Khoshbayani Arani** received his B.S. degree in Mechanical Engineering from Sharif University of Tehran in 1992, his M.S. in mechanical engineering from Tabriz University in 1995 and received his Ph.D. degree in Mechanical Engineering from Islamic Azad University, Science and Research Branch, Tehran in 2011.

**Nima Rasekh Saleh** received his B.S. degree in Science and Research Branch, Islamic Azad University, Tehran in 2002, his M.S. in Esfahan University of Technology in 2005 and received his Ph.D. degree in Mechanical Engineering from Islamic Azad University, Science and Research Branch, Tehran in 2011.