

# TECHNOLOGICAL DEVELOPMENT OF DRIVING SUPPORT SYSTEMS BASED ON HUMAN BEHAVIORAL CHARACTERISTICS

Shunichi DOI

*Professor  
Faculty of Engineering, Kagawa University  
Kagawa, Japan*

*(Received July 3, 2006)*

Driving support and cruise assist systems are of growing importance in achieving both road traffic safety and convenience. Such driver support seeks to achieve, with the highest possible quality, nothing less than “driver-vehicle symbiosis under all conditions.” At the same time, many traffic accidents result from improper driver behavior. The author focuses on driver behavior under various driving conditions, conducting detailed measurement and analysis of visual perception and attention characteristics as well as perceptual characteristics involved in driving. The aim in doing so is to support research on driving support systems and driving workload reduction technologies that function as human-vehicle systems and take such characteristics into account.

**Key Words:** Driving behavior, Driving support systems, Human-machine interface, Active safety, Human characteristics

## 1. INTRODUCTION

With increasing vehicle computerization, driving support and cruise-assist systems are of growing importance in achieving both road traffic safety and convenience. Such driving and cruise support for drivers seeks to achieve, with the highest possible quality, nothing less than “driver-vehicle symbiosis under all conditions.” At the same time, many traffic accidents result from improper driver behavior, that is, errors in the sequence of recognition, judgment and operation.

Driving behavior is the control of a vehicle through a process of driver recognition, judgment and operation based on environmental information input, and functions as a human-vehicle-environment system with constant feedback in the form of information from the outside world and the kinetic state of the vehicle. Accordingly, an understanding of the human characteristics related to the actions involved in driving and the mechanisms by which drivers recognize their surroundings is indispensable to the development of driving support technologies. It is also important to approach the issue in terms of all three elements: humans, vehicles and the environment. Here, we can point out the following issues related to driving support technology aimed at accident reduction, as indicated in Figure 1: 1) driver recognition and judgment characteristics; 2) understanding the relationship between

traffic environment and driving psychology; 3) the nature of the interface linking driving behavior and support systems; and 4) solutions for preventing human error. In addition, with regard to issues of recognition and psychology, it is also desirable to be attentive to the latest advances in research on the brain and nervous system, which underlie human characteristics. Discussing driving support technology in terms of human characteristics and proposing ways to reduce traffic accidents are matters of the highest priority.

Meanwhile, with the increasing computerization of vehicles and the advances in intelligent transportation system (ITS) technology in recent years, preventing the data processing errors attendant to adoption of in-vehicle information devices and systems like car navigation systems has grown in importance and interface design that reduces driving load is now indispensable. This has led to research in recognition, perception and behavioral characteristics, including psychological factors involved in decision-making while driving<sup>1-6</sup>. Surveying trends in such research we see a vigorous examination of case studies, including collection and analysis of near-miss incident data and a design approach that takes into account the driving operation characteristics involved in vehicle motion and chassis control<sup>7</sup>. In addition, there has been progress in assessing and verifying the compatibility of advanced driving and cruise support technology with

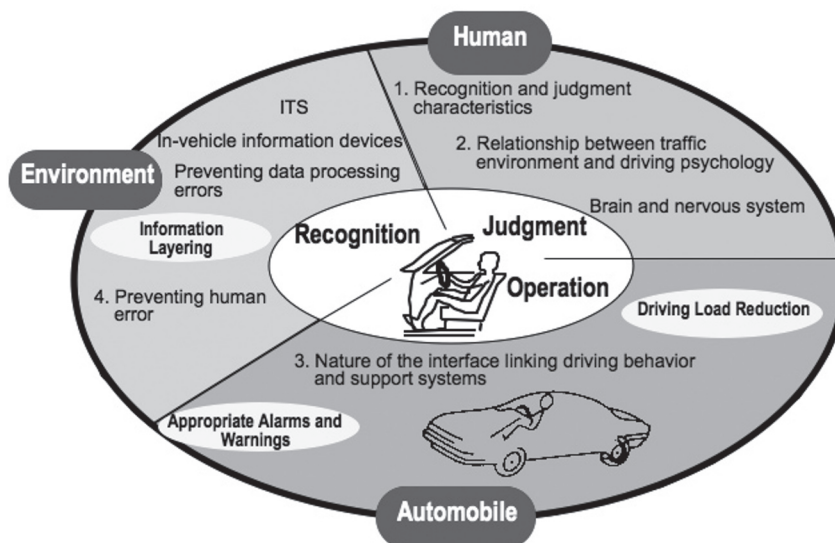

Fig. 1 Strategic domain for driving support system technology

driver characteristics<sup>8,9</sup>.

In this paper we focus on driver behavioral characteristics under various driving conditions and consider visual perception and attention characteristics. We also conduct detailed measurement and analysis of the perceptual characteristics involved in driving. Our goal in doing so is to support basic research on driving support systems and driving load reduction technologies that function as human-vehicle systems and take such characteristics into account.

## 2. DRIVING SUPPORT DEVICES AND HUMAN-MACHINE INTERFACE (HMI) ISSUES

Looking into technological issues and research trends for the near future based on current technological developments, it first seems likely that IT and ITS will gain momentum and society will become markedly more information-driven. In addition, in a society of ubiquitous networks where information is available anytime and anywhere, there will be a need for safer and more convenient driving environments. Furthermore, automobiles tailored to such societal trends will increasingly be in demand.

Figure 2 organizes driver interface issues related to driving safety support and cruise assist systems by driving condition category (expressways, ordinary roads or urban areas). The diagram envisions misinformation and system trouble at the point of contact between driver and device and organizes the issues facing systems in preventing such problems. As can be seen, an approach

based on the analysis of driving behavior and other human recognition and perceptual characteristics remains important in overcoming the issues that accompany computerization. In addition, trends in user diversification, aging and individualization demand more sophisticated methods for evaluating such characteristics. In other words, an approach rooted in human behavior is required when looking at the human attention allocation and information processing mechanisms that determine the convenience of driving support for drivers.

## 3. DRIVING BEHAVIOR CHARACTERISTICS

### 3.1 Driving processes and support system approaches

Driving behavior can be conceived, as mentioned above, as a chain of consecutive behaviors, with individual behaviors and their causes seen in light of traveling conditions and driver psychological state. Drivers are first aware (recognize and perceive) their situation, then engage in decision-making and response selection, and finally execute individual operations. Both driving conditions, that is, information from the outside world, and vehicle conditions change from moment to moment. Depending on which process within this chain of behaviors one looks at, one can envision different corresponding driving support systems. Seen in this way, as described in Figure 3, depending on how one analyzes driving behaviors, there is a three-stage approach for systems supporting various driving processes: 1) measurement of

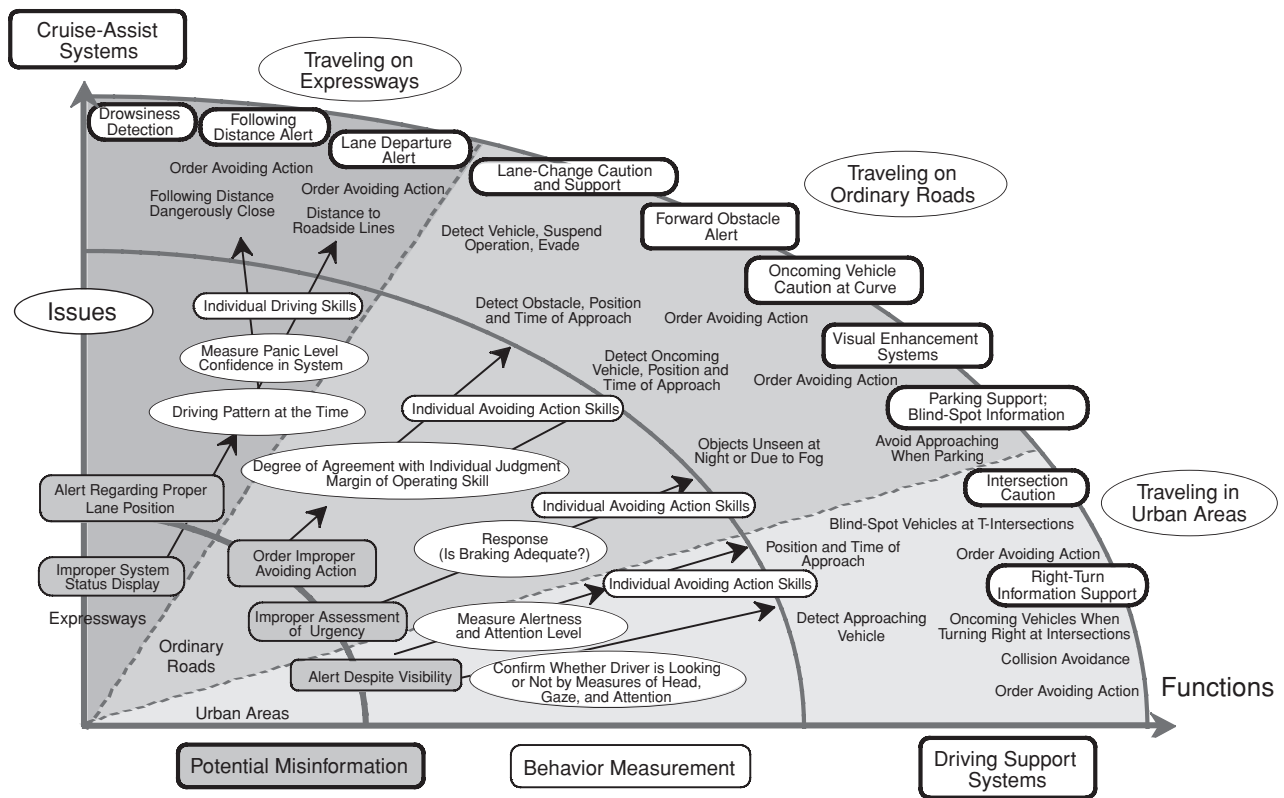

**Fig. 2 Driving support devices and human-machine interface issues**

phenomena, 2) their interpretation and analysis, and 3) system application.

In terms of driving behavior analysis, the goal in characterizing the most direct processes of driving operation and execution include cruise-assist devices and vehicle motion control devices<sup>10,11</sup>. Techniques include the use of driving simulators that mimic actual conditions to measure operational response and analyze operational patterns. In addition, the results of such analysis can be organized in a database of operational behavior and generalized as part of a model of the driving operation behavior sequence. There are, for example, numerous instances where the operability of a given device is measured and analyzed and the results applied to the development of a new system.

Behavioral analysis of the most upstream of driver behaviors – the recognition and perception process – is related to visual perception support for accident prevention and seeks to provide information support and in-vehicle display of information on factors such as road conditions and the speed and position of forward vehicles. In the area of basic perceptual characteristics, too, there are examples such as the development of suspen-

sion systems designed to improve vehicle comfort based on evaluations of vibration sensitivity characteristics.

### 3.2 Driver characteristics and support system diversity

Efforts to analyze characteristics of the judgment process, including the most difficult areas of decision-making and response selection, are strongly related to aspects of driver performance such as mental workload, distraction and reduced consciousness. Their goal is to contribute to the design of support systems that provide reminders or warnings to drivers, fostering situational awareness and helping drivers assess risk<sup>12</sup>. Here, to cope with the individualization and diversification of users, there is a need to prevent human error by managing the risks associated with the data processing workload accompanying vehicle computerization and by targeting the way safe driving is taught in driver education.

There are a number of issues common to such analysis of driving characteristics. First, there is a need for noninvasive measurement methods that take place in real-time without adding materially to driver workload. Analysis also requires methods for building models that

Process	Situation Awareness (Recognition and Perception)	Decision-Making and Response Selection	Operation and Execution	Issues in Common
<b>1. Measurement of Phenomena</b> Approach Physiological measurement Cognitive measurement Proximity detection Characteristics of perception and sensitivity	Stopping and passing decisions Dilemma measurement Mental workload Driving psychology analysis	Technology for analyzing emergency operating behavior Technology for analyzing braking characteristics Analysis of following behavior Physical workload	Noninvasive measurement Real-time measurement Driving simulation technology	
<b>2. Interpretation and Analysis</b> Visual human error Characteristics of visual attention Quantification of traffic conditions Readability of information display	Techniques for grasping behavioral context Fatigue and driving performance Driving performance at times of reduced consciousness	Techniques for structuring behavior (behavioral models) Effect of workload on driving behavior Techniques for analyzing inattentiveness	Mechanism analysis Mechanism of human error occurrence	
<b>3. System Application</b> Visual support at night or when dark Recognition and perception support Improving readability and visibility of roadside signage	Preventing fatigue-related driving accidents Preventing inattentive driving Preventing intersection accidents Reminders, alarms and cautions	Support for emergency avoiding steering Technology for preventing rear-end collisions Technology for making support devices adaptive Driving stability control	Over-reliance on system Inattention Risk management	
<b>Driving Support</b>	Safe road signage Information display devices	Driver support Driving support devices	Cruise-assist devices Vehicle control devices	

Fig. 3 Driving processes and approaches to driving support systems

take behavioral context into account and that can be generalized. In system application, too, there is a need to cope with system over-reliance and the inattention to which it can lead. In each case, what is required is not so much a single systematic method as a comprehensive strategy involving a combination of methods.

#### 4. RESEARCH BASED ON VISUAL PERCEPTION AND ATTENTION CHARACTERISTICS

##### 4.1 Depth attention experimental environment

One of the most complex and difficult to measure aspects of the recognition and judgment process is cognitive evaluation and analysis. In short, because it is a matter of how best to provide judgment support for drivers in the course of recognition support and cruise assistance, and also related to the issue of when to prompt drivers to make decisions, there are great difficulties in execution related to how to cope with individual variation. In addition, there is also a need to evaluate both the safety of

information provided to drivers and the impact of driving support on principal driving behaviors, evaluations needed to derive critical standards for building infrastructure.

Looking at the attention that drivers direct forward of their vehicles while driving, research in the area has considered the range of view subjected to attention (for example, whether it is an effective field of vision) and whether the capacity of such resources is adequate<sup>13</sup>. At the same time, research has also been done on the characteristics of depth attention when following other vehicles, which leads to many accidents<sup>14</sup>. Here, we conducted basic research to investigate the status of depth attention in responding to a visual task in a laboratory simulation. Figure 4 illustrates the structure of the experiment. The dynamic depth attention experimental apparatus used involved moving the test subject through an 8m-long tunnel-like corridor while seated on a wagon. The stimulus was numeric LEDs located in the subject's forward line of sight, with the fixation point indicated at a distance of 120cm from the subject. Targets were established at two locations each before and after the fixation point, at dis-

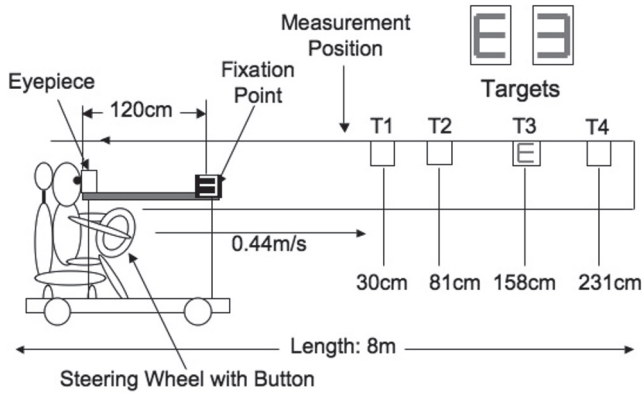

**Fig. 4 Depth attention experimental apparatus**

tances from the observer of 30cm and 81cm (before) and 158cm and 230cm (after). The observer was moved at a speed of 0.44m/s, which, looking through an eyepiece, created the visual sensation of traveling at 80km/h.

Subjects were provided with information in advance about where targets would appear, and reacted accordingly. This information was a valid clue (V) 65% of the time, an invalid (I) clue 15% of the time and a neutral (N) clue (equivalent to no clue) 20% of the time. The test was run 320 times.

The fixation point, starting 1000ms after initiation of the test, provided the subject with a clue to the location of the target in the form of numeric LEDs (1 through 4) that remained on through the lighting of the target display and the subject's reaction. The subject's task was to determine the shape displayed at the target (E or 3) and correctly press the corresponding button as quickly as possible. Within the I condition, although absolute target depth varied, cases where the perspective relative to the focal point was unchanged (such as, in the diagram, T2→T1 [T2 given as a clue but T1 lit] and, similarly, T3→T4) were coded as invalid-same (Is). On the other hand, cases where both the absolute positions of clue and target and their relationship to the fixation point changed were coded as invalid-different (Id) (for example, T1→T4 and T3→T2). Furthermore, the light level in the experimental apparatus was set at 480 to 680lx for the bright condition and 95 to 135lx for the dim condition. In the interest of arranging test conditions, the N condition was understood to be the normal driving condition. The differences between N and V conditions were considered benefits (promoting reaction) while those between I and N conditions were considered costs (inhibiting reaction). There were 11 young test subjects, whose average age was 20.8 years old.

**4.2 Response lag characteristics due to attention bias**

Figure 5 indicates response time for the dynamic depth attention experiment under various clue conditions. Reaction time was slower for I than for either V or N, and fastest for V, indicating the effectiveness of a clue. Within the I condition, reaction time was slower for Id than for Is, indicating the impact of the distance of the shift in attention. Reaction time was also greater when attention shifted from near to far than when shifted from far to near, indicating that attention shift is directionally dependent.

Furthermore, Figure 6 shows how the accumulation of such quantitative data can clarify the relationship between positional shifts of attention when distracted and depth recognition response time, and confirms the possibilities for dealing with spatial attention characteristics.

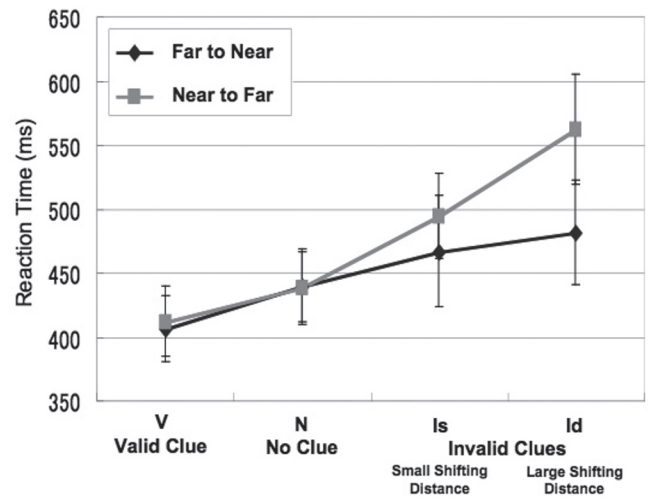

**Fig. 5 Reaction time and attention bias conditions**

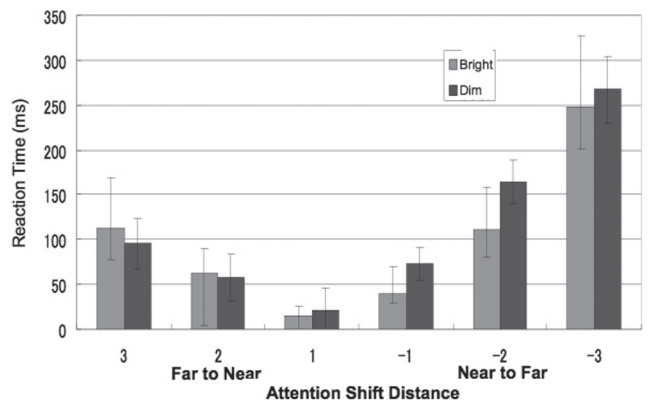

**Fig. 6 Reaction time by attention shift distance (bright and dark)**



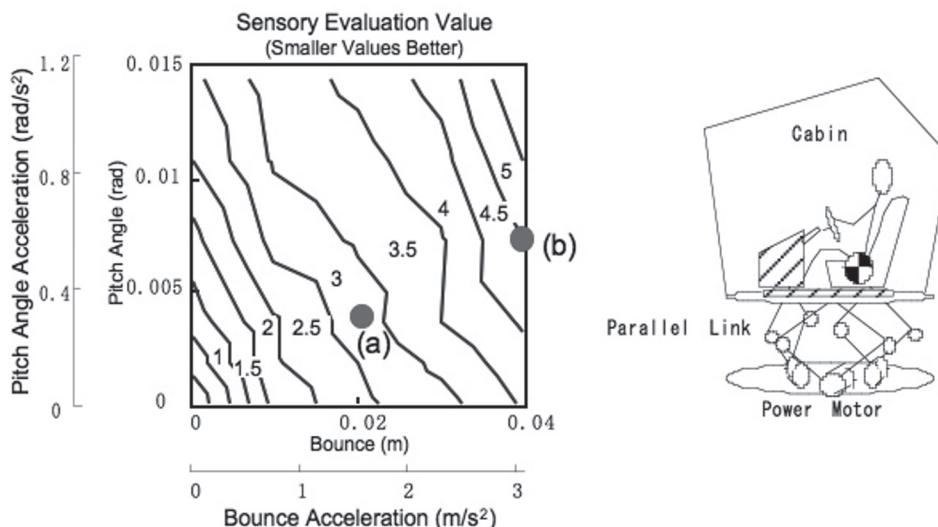

Fig. 7 Discomfort curves for multi-axial vibrations

Research on basic human attention characteristics such as the above, as in near-miss analysis, is important for understanding the mechanism of attention deficit, a human error factor. Such research will undoubtedly continue to make progress in solving human interface issues.

## 5. DESIGNING A HUMAN-VEHICLE INTERFACE BASED ON KINETIC PERCEPTION CHARACTERISTICS

### 5.1 Clarifying characteristics of sway/vibration perception

Next, unlike the visual recognition and judgment characteristics that accompany active attention, we looked at the mechanism of passive kinetic perception. That is, we understood vehicle body vibrations to be changes in vertical motion (bounce) and angles of rotation about the horizontal axes (pitch and roll) and conducted an experiment to investigate human sensory characteristics under such conditions. The experimental apparatus, a shaking device that incorporates a parallel link manipulator with six degrees of freedom, can reproduce the translational and rotary motions mentioned above at will.

As Figure 7 indicates, an examination of sensitivity to vibrations such as the bound and pitch experienced when cruising on greatly undulating roadways rendered discomfort curves for multi-axial vibrations and demonstrated that each vibration component is important. In addition, Figure 8 indicates the results of subjective evaluations when the phases of the two vibration components were varied. That is, the diagram shows that the

phase difference as well as the size of multi-axial vibrations is a significant characteristic of human bodily sensation and suggests how to optimize vehicle body vibrations based on such factors. In concrete terms, such research has made it easier to adjust front and rear suspension springiness and damping force characteristics<sup>15</sup>.

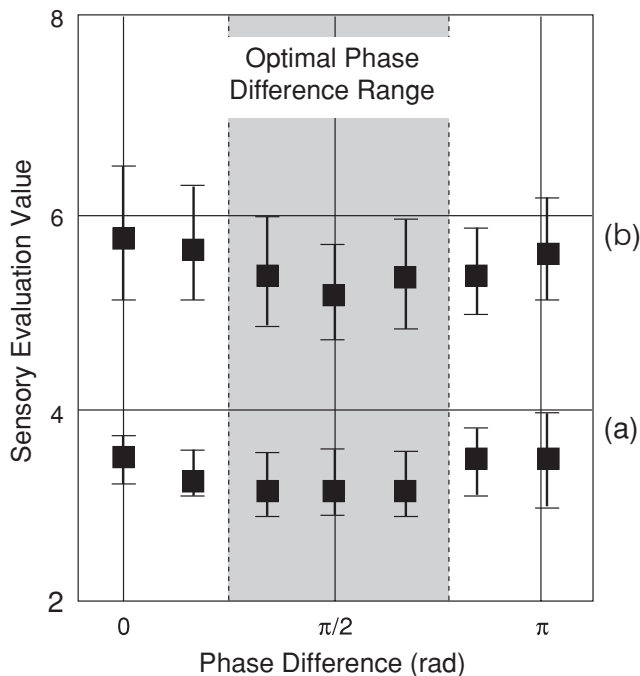

Fig. 8 Multi-axial vibration phase difference and subjective evaluation

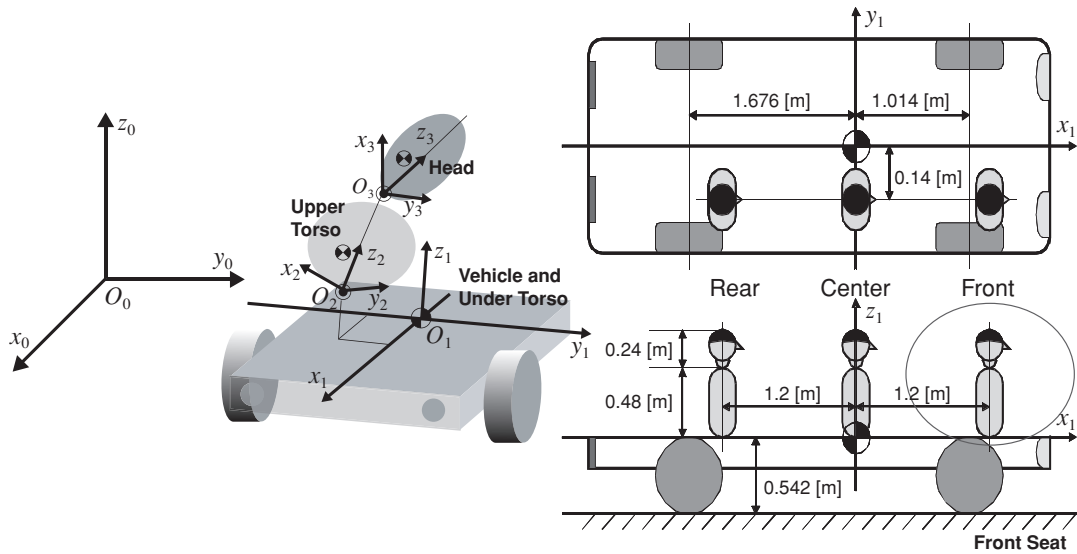

Fig. 9 Occupant model and riding positions

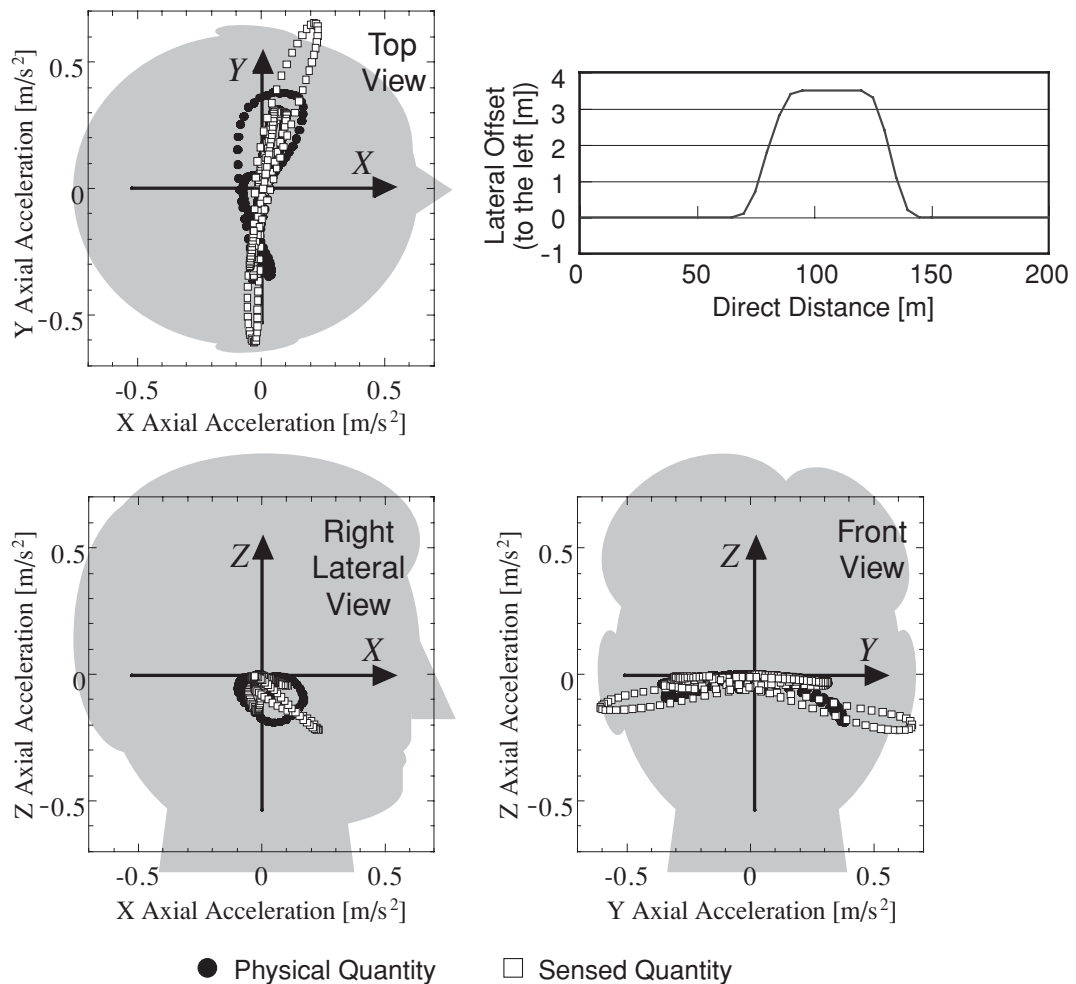

Fig. 10 Physical simulation and degree of sensation for front seat occupant (speed 40km/h)

### 5.2 Evaluating predicted bodily sensation with a sway perception mechanism model

Bodily sensation characteristics for sway and vibration are known to be determined by the response characteristics of the semicircular canal and otolith organ in the human ear. Therefore, we created a sway perception model based on the operating characteristics of the vestibular organ that governs sway perception in humans<sup>16,17</sup> and used it to evaluate predicted sensitivity<sup>18</sup>. Figure 9 illustrates a simplified occupant model with assumed riding positions. We assumed a wagon-type vehicle with occupants positioned in each of the three rows of seats. We then hypothesized various driving conditions and calculated the degree of sway for each occupant in each seat as well as the degree of perceived sway based on hypothesized vestibular organ characteristics.

Figure 10 indicates one example of our results, using Lissajous waves to illustrate in three dimensions the degree of physical acceleration and perceived sway for the head of a front seat occupant located 1.2m in front of the vehicle’s center of gravity when performing a double lane change at a speed of 40km/h. In all cases we calculated the motion of the chest and head that accompany vehicle motion and used the degree of physical head movement to compute the sway perceived by the occupant. The right lateral view of the occupant’s head indicates that acceleration is not only perceived laterally but also diagonally forward and down, while the top and front views indicate that even under simple cruising con-

ditions such as a double lane change the perceived degree of sway acceleration greatly exceeds actual acceleration of the head.

In this way, it is possible to derive the dynamics of the vehicle-head system, derive head behavior accompanying vehicle motion, convert physical stimulus into perceived sway and express occupant sensations accompanying vehicle motion as numerical values. Our investigation clarified the influence of differences in vehicle speed and seat position on occupant head behavior and perceived sway, and demonstrated that turning characteristics have a great effect on occupant head behavior.

### 5.3 Predicting the effectiveness of driving support systems

The following summarizes the flow for predicting the effectiveness of driving support system performance. Developing driving support or cruise assist devices for vehicles requires the evaluation of a broad range of driving behavior characteristics including driver operational behavior patterns, avoiding operational behavior in time of emergency and individual variation between the young and the old or the petite and the heavyset. Parameters and threshold values for, say, motion control are established based on this massive amount of behavioral characteristics data. Here we analyze control system design issues by building a behavioral model that encompasses general and emergency driving behavior such as braking and steering operations and by regarding the model of driver

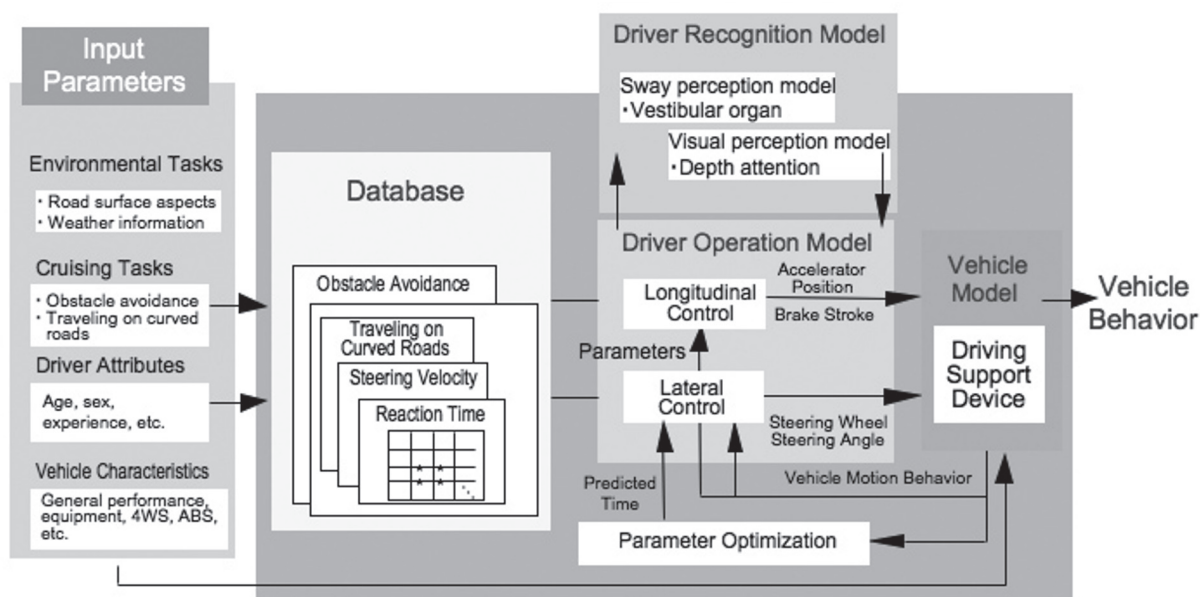

Fig. 11 Predicting driving support performance as a driver-vehicle system



and vehicle motion as a human-vehicle system.

Figure 11 presents a block diagram of the flow for predicting driving system performance as a human-vehicle system. Here, we predict the performance of driving support devices by conceiving of the inputs as traveling environment, road configurations and driver characteristics in a model that integrates driver recognition, perception and operating characteristics as well as vehicle motion. Examples of vehicle control development based on such human-vehicle system analysis include stabilization controls that actively apply input to steering systems, such as four-wheel steering and wind-effect compensation. Driver support devices that have been developed include road deviation compensation, reactive force control of electric steering systems and steering gear ratio control, which can be brought together in complex active control systems for steering and braking or steering and suspension systems.

## 6. SUMMARY AND FUTURE OUTLOOK

As described above, the field of study in driving behavioral characteristics is vast, and multidisciplinary technological development that takes driving behavioral characteristics into account is underway. Such development involves measuring phenomena, analyzing and un-

derstanding such measurements, and applying the results to active safety technology. Here, in Figure 12, we propose a map of future research themes in active safety technology development based on the state of current technology. Essentially, organizing the research issues related to human characteristics as seen in terms of driving support system development requires a great deal of human condition analysis based on safety, convenience and information.

At the same time, the society of today involves growing reliance on computerization and symbiotic relationships between drivers and their vehicles; the future demands the harmonious development of people, cars and society. That is, it is important that driving support preserves in the driver the attention performance that driving demands, while both ensuring safety and pursuing convenience in door-to-door transportation. In addition, the comfort of automobiles as mobile spaces is an important area for research, just as is their safety and security as means of transportation<sup>19</sup>.

To address these issues, as described above, there is a need to: 1) clarify the structure and mechanism of complex characteristics with multiple interrelated factors and to conduct multifaceted behavioral analysis based on such mechanisms; and 2) increase our ability to analyze simultaneously occurring behavioral elements and de-

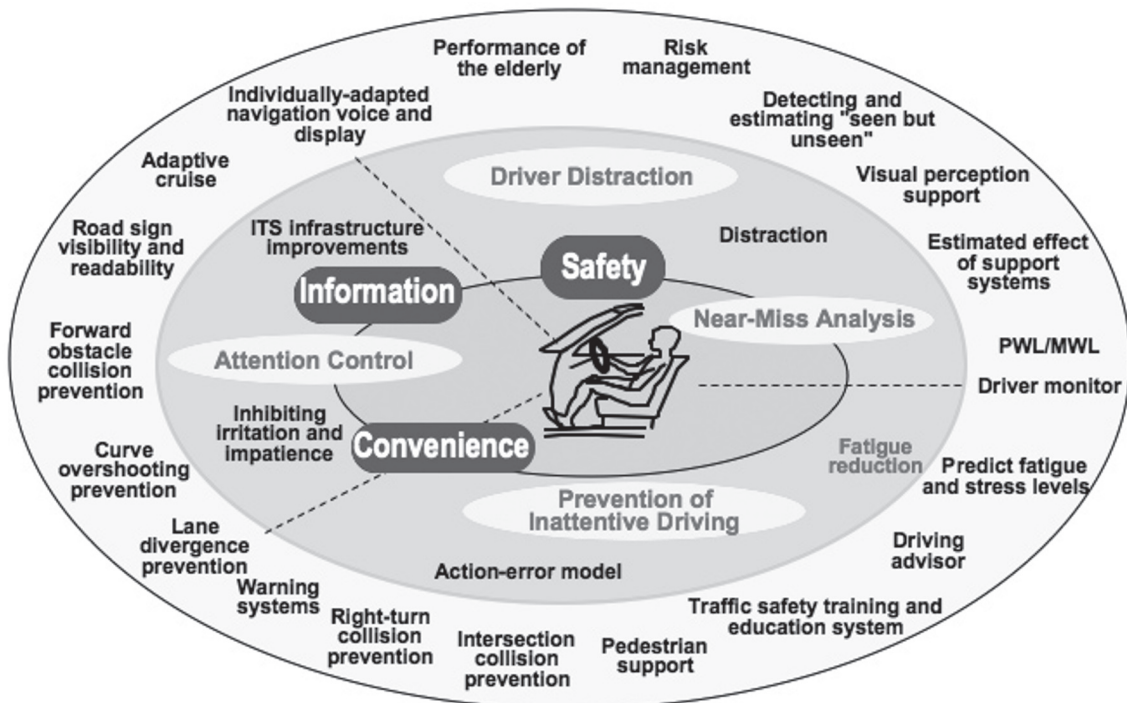

Fig. 12 Map of research themes for driving support systems and human characteristics

velop methods for analyzing overlapping results.

Many of our predecessors have said that an automobile must be something a person enjoys gripping the wheel to drive, something comfortable with a pleasant vibration and sound, something exciting that stirs the emotions. The pursuit of such comfort in maneuverability and ride remains an important theme, but ways to reduce driving workload and fatigue when driving for long periods of time and the development of technology to maintain safe driving are also indispensable for realizing the ultimate in active safety. We look forward to further advances in research that takes a broad perspective in considering such issues.

## REFERENCES

1. S. Doi. Active Safety in Car Design. *International Encyclopedia of Ergonomics and Human Factors, Vol.2, Part 6, Workplace and Equipment Design*. Taylor & Francis Books. (2001).
2. T. Wada, S. Doi, Y. Takahashi, K. Isaji, N. Tsuru, H. Kaneko. A Proposal of Dynamic Visual Field as a New Measure of Visual Function While Driving. Proceedings of the 12th World Congress on Intelligent Transport Systems, Paper Number 3239, San Francisco. (2005).
3. T. Asao, T. Wada, S. Doi. The Effect of Physical Workloads on Driving Performance. Proceedings of the 19th International Technical Conference on Enhanced Safety Vehicles, Paper Number 05-0435, Washington D.C. (2005).
4. W. Reichelt, P. Frank. Driver Assistance Systems to Improve Active Safety in the Closed-Loop System Driver-Vehicle Surroundings. "International Journal of Vehicle Design" 18(6): pp.639-651. (1997).
5. Rompe, K., et al. Comparison of the Braking Performance Achieved by Average Drivers in Vehicles with Standard and Anti Wheel Lock Brake Systems. "SAE" No.870335. (1987).
6. R.W. Allen, et al. Analysis and Computer Simulation of Driver/Vehicle Interaction. "SAE" No.871086. (1987).
7. S. Doi, et al. Improvement of Vehicle Motion and Riding-Comfort by Active Controlled Suspension System. "Transactions of American Society of Automotive Engineers" No.910662. (1991).
8. T. Kamada, et al. Experimental Study of Forward Collision Warning System Adapted for Driver Characteristics. DSC Asia/Pacific-Tsukuba. (2006).
9. <http://humans.eng.kagawa-u.ac.jp/~wada/>
10. S. Doi, S. Nagiri, Y. Amano, K. Fukui, T. Taguchi. Research and Development of Driving-Support System for Individual Driving Ability. Triennial Congress of International Ergonomics Association. (2003).
11. S. Nagiri, et al. The Study of Driver Support for Individual Drivers. IEEE International Conference on Systems, Man and Cybernetics. (2002).
12. E.R. Boer, et al. Driver Performance Assessment with a Car Following Model. Proceedings of the 3<sup>rd</sup> International Driving Symposium on Human Factors in Driver Assessment, Training and Vehicle Design: pp.433-440. (2005).
13. T. Miura. Visual Search in Intersections: An Underlying Mechanism. "IATSS Research" 16(1): pp.42-49. (1992).
14. T. Kimura, T. Miura, S. Doi, Y. Yamamoto. The Advantage of Near Space in the Case of Attentional Switching in Three-Dimensional Space. European Conference on Visual Perception, Hungary. (2004).
15. K. Kushiro, E. Yasuda, S. Doi. An Analysis of Pitch and Bounce Motion Requiring High Performance of Ride Comfort. The 18<sup>th</sup> IAVSD Symposium. (2003).
16. T. Maruo, N. Kamiji, T. Wada, S. Doi. Effect of Visual and Vestibular Stimuli on Equilibrium Function in Young and Elderly Individuals. Proceedings of International Conference on Instrumentation, Control and Information Technology: pp.2842-2847. Okayama. (2005).
17. D.M. Merfeld. Modeling Human Vestibular Responses During Eccentric Rotation and Off Vertical Axis Rotation. "Acta Otolaryngol" Suppl, 520: pp.354-359. (1995).
18. N. Kamiji, et al. Modeling and Simulation of Motion Sensation Evoked by Vehicle Behavior. DSC Asia/Pacific-Tsukuba. (2006).
19. E. Fujita, et al. Development of a Method for Measuring Sleep Predictor Signals via Biological Signals in the Hip Region. Proceedings of the 11<sup>th</sup> Asia-Pacific Vibration Conference, Vol.2: pp.427-431. (2005).