

# Impact of ASHRAE's museum climate classes on energy consumption and indoor climate fluctuations: Full-scale measurements in museum Hermitage Amsterdam



R.P. Kramer\*, H.L. Schellen, A.W.M. van Schijndel

Department of the Built Environment, Eindhoven University of Technology, Groene Loper 6, 5600 MB, Eindhoven, The Netherlands

## ARTICLE INFO

### Article history:

Received 1 April 2016

Received in revised form 13 July 2016

Accepted 3 August 2016

Available online 22 August 2016

### Keywords:

–Energy

Saving

Museum

Historical building

Ashrae

## ABSTRACT

In the 20th century, museum indoor climates have been conditioned ever more strictly, sometimes beyond guidelines, allowing no fluctuations at all. Among other effects, this has led to excessive energy demands. At the start of the 21st century, interest has increased to condition the indoor climate more reasonable. This study assessed the energy impact of three levels of museum climate control: Reference (21 °C/50% RH, no permissible fluctuations), ASHRAE's Class AA, ASHRAE's Class A. Full-scale measurements were conducted in the museum Hermitage Amsterdam for one year. The results show that Class AA saved 49% and Class A saved 63% compared to the Reference setpoint strategy. Moreover, relaxing the climate specifications decreased hourly fluctuations, but increased daily fluctuations. It is highly likely that the overall degradation risk has not significantly changed for most artefacts.

© 2016 Elsevier B.V. All rights reserved.

## 1. Introduction

The indoor climate conditions of museums, archives, galleries, and libraries are of utmost importance to provide adequate conditions to preserve the artefacts [1]. This also holds for historical buildings if the interior and the building structure itself are of cultural significance [2]. Besides, the indoor environment should provide thermal comfort to visitors and staff.

Indoor climate guidelines have been developed as for example by the American Society of Heating Refrigeration and Air-conditioning Engineers (ASHRAE), presenting indoor climate classes for Museums, Galleries, Archives, and Libraries. ASHRAE's chapter on the museum indoor climate includes a table providing specifications for short-term fluctuations, long-term fluctuations and permissible levels of both indoor temperature (T) and indoor relative humidity (RH) [3], further referred to as 'the specifications'. The table presents climate classes ranging from Class AA (precision control) to Class D (relaxed control). A vast amount of practical and theoretical knowledge forms the basis of these specifications [4]. The table with indoor climate specifications included some new concepts when it was published the first time in the late 1990's [4]:

(i) setpoints may vary from the standard annual average of 50% RH; (ii) estimated risks are provided for each class; (iii) a wide range of options for seasonal adjustments for energy efficiency.

The specifications were not intended to be prescriptive, but the entire chapter provides a framework of knowledge to help develop custom climate specifications for any particular museum. However, without profound knowledge on many factors affecting the risk profile for the collection, and possibly historical building, a translation from a risk profile agreed upon into climate specifications is very difficult. These factors may include, for example, the composition and sensitivity of the collection, construction of the building, outdoor climate conditions, impact of visitors, and impact of lighting systems.

The notion of an optimal museum environment evolved in the 20th century to 'the more stable, the better': not the collection, nor the building requirements, but the capabilities of the HVAC systems determined the level of indoor climate conditioning [5]. As a consequence, specifications in guidelines were often used as prescriptive and many museums chose the most strict indoor climate class (AA), supposing this to be the optimum overall solution. However, conditioning the indoor climate of museums according to a strict climate class results in excessive energy consumption. Moreover, historical building structures suffer from side effects like moisture vapor condensation in winter [5]. Also, it has been shown that the desired strict indoor climate in most historical buildings, despite complex air-conditioning systems, is frequently not realized [6]. Moreover,

\* Corresponding author.

E-mail addresses: [r.p.kramer@tue.nl](mailto:r.p.kramer@tue.nl) (R.P. Kramer), [h.l.schellen@tue.nl](mailto:h.l.schellen@tue.nl) (H.L. Schellen), [a.w.m.v.schijndel@tue.nl](mailto:a.w.m.v.schijndel@tue.nl) (A.W.M. van Schijndel).

no evidence has been found that these less strict indoor climates result in collection damage [6].

At the beginning of the 21st century, energy efficiency had become an increasingly important issue for museums, storage rooms, libraries and historical buildings as energy bills kept increasing and sustainability had become an important topic [7–10]. On the other hand, there is a lag of insight in the relation between climate class and energy consumption.

This study aims to provide insight into the energy saving potential of conditioning the museum indoor climate more reasonable. Three levels of museum climate control have been tested in Museum Hermitage Amsterdam (Amsterdam, the Netherlands) for one year: the Reference setpoint strategy comprising 21 °C and 50% RH without permissible fluctuations, ASHRAE Class AA, ASHRAE Class A. Comparing energy consumptions is based on full-scale dynamic measurements of the AHU (Air Handling Unit) system. Furthermore, measurements of indoor climate conditions provided insight into the effects of the tested classes on T and RH fluctuations.

There are four further sections in this paper. Section 2 describes details of the case study, Section 3 presents the methodology, including data acquisition and testing of the climate classes. Section 4 presents the results, and Section 5 the discussion and conclusions.

## 2. The case study: museum Hermitage Amsterdam

The museum Hermitage Amsterdam is a sister of the State Hermitage Museum in St. Petersburg, Russia. The museum is located in Amsterdam, the Netherlands. Museum Hermitage Amsterdam has no own collection, but displays loan exhibitions: The artworks mainly belong to the State Hermitage Museum, but also to other museums. The museum is opened seven days per week from 10 h until 17 h and has been welcoming 7,000 to 11,000 visitors per week, depending on the exhibition. The employed indoor climate specifications were 21 °C and 50% RH without permissible fluctuations, aiming for a stable museum environment. As a result, seasonal fluctuations are absent in the current indoor climate.

### 2.1. The building

The museum is housed in a late 17th-century building and in the past centuries, the building has been changed frequently. It was substantially renovated in 1970 as it was transformed into a nursing home. The most recent renovation dates from the years 2007–2009 when the building was transformed into a state-of-the-art museum (see Fig. 1). The historical building envelope was conserved and insulated from the inside, floor heating was applied in the non-exhibition areas as the restaurant and foyer, all-air systems were installed to condition the exhibition areas, and an Aquifer Thermal Energy Storage (ATES) system was installed for heat and cold storage in the ground.

Restoring the exterior façade helped to preserve the historical appearance, but all the remaining parts of the building have been rebuilt to accommodate the museum adequately. The building envelope has been upgraded to a high insulation level: external walls have been insulated from the inside (total thermal resistance 3.7 m<sup>2</sup>K/W), glazing has been replaced by double glazing with reflective coatings (U-value 1.8 W/m<sup>2</sup>K), and particular effort has been spent on making the building envelope airtight (infiltration rate < 0.1 h<sup>-1</sup>). We refer to Maas [11] for a comprehensive description of the building materials, floor plans, and detailed drawings.

Fig. 1a shows the layout of the building. The building has a symmetrical floorplan: Two nearly identical exhibition wings may be recognized by the glass roof on the left and right side in Fig. 1a. The central part, in the top of Fig. 1a, accommodates the main entrance, a restaurant, an auditorium, and restrooms.

This study focusses on ‘de Keizersvleugel’, which is the exhibition wing on the right side in Fig. 1a. The wing consists of three exterior surfaces: the roof, a façade adjacent to the courtyard which is oriented to the North-West, and a façade adjacent to the canal which is oriented to the South-East. The exhibition area consists of the main hall (Fig. 1b) and adjacent cabinets (Fig. 1d). Visitors enter the exhibition area via the stair from the foyer (Fig. 1c). The ceilings of the exhibition cabinets adjoin the technical areas located on the top floor. The ceiling of the main exhibition hall partly consists of a large glass roof with interior sun blinds that were closed almost permanently during the measurements. An air curtain has been applied to reduce the interzonal air exchange between the main exhibition room and the foyer. During closing hours, this interzonal air exchange is absent due to the closing of fire protection doors.

### 2.2. Internal heat and moisture gains

The visitors’ impact on temperature and humidity consisted of three factors: Heat production, moisture production and outdoor air supply by a CO<sub>2</sub>-controlled ventilation system. The measurement campaign has been executed over a period of one year without a change of exhibition. This resulted in a repeatedly weekly visitor profile. At Sunday, Tuesday and Wednesday most visitors attended the museum, on Monday the least.

Besides, the lighting systems influence the indoor climate by emitting heat via convection and radiation. All lighting systems included halogen lamps at the time of measurements. Although halogen lamps itself generate a significant amount of heat, the overall heat production by lighting systems was limited due to the low illuminance levels. Note that dyes and pigments exposed to light fade or change appearance, so illuminance levels are limited in most museums to 200 lx and 50 lx for very sensitive objects. The average heat load by lighting, determined by dividing the total lighting power by the exhibition’s floor area, was 9 W/m<sup>2</sup>.

### 2.3. Exhibition room’s AHU

An AHU air conditions the main exhibition room of interest, see Fig. 2 for an overview. From left to right the AHU consists of a mixing section (outdoor air mixed with recirculation air), dust filter, cooling coil, steam humidifier, dehumidification coil with bypass, fan, heating coil, and a filter section (electrostatic, chemical-active carbon and end filter).

Most of the time all air is being recirculated. The outdoor air valve controls the supply of fresh outdoor air when the CO<sub>2</sub>-level exceeds a threshold value of 1000 ppm. The CO<sub>2</sub>-level is measured in the exhibition room. Usually, fresh outdoor air is supplied between 14 h and 17 h.

The counter-flow cooling coil consists of four rows and its designed capacity is 55 kW with a water supply temperature of 12 °C and return temperature of 16 °C. The counter-flow dehumidifying coil consists of eight rows and its designed capacity is 111 kW, but this is reduced to 74 kW because of the bypass construction, with a supply water temperature of 6 °C and a return water temperature of 10 °C. The counter-flow heating coil consists of four rows and its designed capacity is 128 kW with a supply water temperature of 45 °C and a return water temperature of 35 °C.

The steam humidifier has a maximum capacity of 18 kg/h with an electrical power supply of 15 kW. PI-modulation controls the steam injection rate.

The belt driven centrifugal fan with backward-curved blades has a maximum shaft power of 9.74 kW and a maximum air displacement of 6.11 m<sup>3</sup>/s. It provides an air flow of 16,000 m<sup>3</sup>/h resulting in an air change rate of 7.5 h<sup>-1</sup>.

A comprehensive filter section completes the AHU: An electrostatic filter to remove mold, micro dust, pollen and other allergens;



**Fig. 1.** a) Aerial view of Museum Hermitage Amsterdam. b) The entrance stair to the main exhibition room. c) One of two main exhibition halls. d) Cross section of the main exhibition room and adjacent cabinets (image: Hans van Heeswijk Architects).

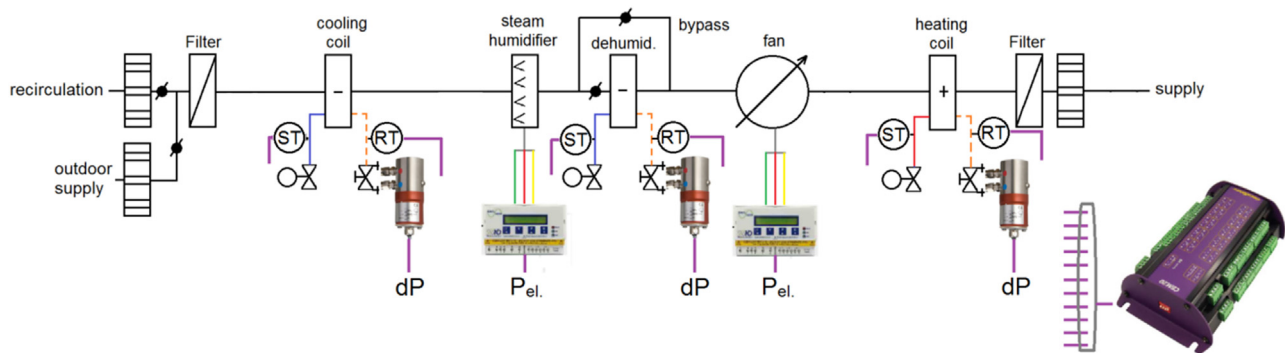

**Fig. 2.** Measurement setup of the main exhibition room's AHU. The data logger logged all signals (purple lines) at an interval of 30 s. Coil measurements included temperatures of the supply water (ST), return water (RT) and pressure drop of the water flow over the balancing valves (dP). Electric power consumption was measured of the steam humidifier and fan ( $P_{el}$ ).

An active carbon filter to remove contaminant gasses as ozone and formaldehyde by adsorption, absorption, and oxidation; An end particle filter.

#### 2.4. The collection

The exhibitions in the Hermitage Amsterdam present works of art and artefacts with historical relevance. The exhibitions' duration vary between six months and several years. The museum works predominantly with loans from the State Hermitage Museum (St. Petersburg, Russia), but incidentally exhibitions have been developed in cooperation with other museums, e.g. the Amsterdam Museum (Amsterdam, The Netherlands).

The exhibition during the measurement campaign 'Napoleon, Alexander and Josephine', elaborated on the relations between the three main characters, the resulting political consequences, and their acquired art collections. The following artefacts were displayed: weapons, uniforms, wooden and marble sculptures, fur-

niture, letters, and many canvas paintings. The latter being the most sensitive objects of the exhibition, besides very sensitive objects, e.g. original letters, which were placed in display cases.

The indoor climate requirements in the Hermitage Amsterdam followed from the loan agreement with the State Hermitage Museum: 21 °C and 50% RH, without permissible fluctuations. This might seem in contradiction with the experienced historical climate: the indoor climate in the State Hermitage Museum is characterized by lower levels of RH in winter and higher levels of RH in summer. When the artefacts arrive in Amsterdam, they are kept in a vault for two weeks that is conditioned according to the climate conditions that the artefacts have been exposed to before. During these two weeks, the climate conditions of the vault are incrementally adjusted towards 21 °C and 50% RH.

Especially for this study, the indoor climate was allowed to be conditioned according to ASHRAE's climate class AA (45–55% RH) and class A without seasonal adjustments (40–60% RH).



**Table 1**  
T and RH specifications for collection preservation according to ASHRAE's climate classes AA and A [3].

Type	Set Point or Annual Average	Maximum Fluctuations and Gradients in Controlled Spaces			Collection risks
		Class of Control	Short fluctuations plus space gradients	Seasonal Adjustments in System Set Point	
General Museums, Art Galleries, Libraries, and Archives	50% RH (or historical average for permanent collections)	AA Precision control, no seasonal changes, with system failure fallback	± 5% RH, ± 2 K	RH no change Up 5 K; down 5 K	No risk of mechanical damage to most artefacts and paintings. Some metals and minerals may degrade if 50% RH exceeds a critical RH. Chemically unstable objects are unusable within decades. Small risk of mechanical damage to high vulnerability artefacts; no mechanical risk to most artefacts, paintings, photographs, and books. Chemically unstable objects are unusable within decades.
	Temperature set between 15 and 25 °C	A Precision control, some gradients or seasonal changes, not both, with system failure fallback	± 5% RH, ± 2 K  ± 10% RH, ± 2 K	Up 10% RH, down 10% RH Up 5 K; down 10 K RH no change Up 5 K; down 10 K	
	Note: Rooms intended for loan exhibitions must handle set point specified in loan agreement, typically 50% RH, 21 °C, but sometimes 55% or 60% RH.				

### 3. Methodology

#### 3.1. Data acquisition

Outdoor  $T_a$  and  $RH_a$  were measured at the museum site in Amsterdam and logged by the Building Management System (BMS). The sampling interval was 16 min, but this was converted to hourly values for analysis by nearest point interpolation. This unusual interval results from the method to set the logging interval of the BMS: To set the logging interval, a maximum number of saved data samples per variable may be divided by a factor.

Indoor T and RH measurements were retrieved from the museum's BMS. Four sensors were available in the exhibition room of interest: Hanwell Radiologgers ML4106 combined T and RH measurement providing accuracies of  $\pm 0.2$  °C and  $\pm 2\%$  RH. The sensors are calibrated every year. The logging interval of the indoor measurement data is 16 min. The four sensors are attached to the four walls of the exhibition room at a height of two meters. The average of these four sensors is used for setpoint control.

Because of the fast responses of the AHU-components, a logging interval of 30 s was used. Fig. 2 shows the measurement setup of the AHU (this is not part of the BMS, but installed by the university's technicians).

The energy consumptions of heating, cooling, and dehumidification were calculated based on the energy exchange between the water side and air side of the coils according to,

$$P = \dot{m}_w C_{p_w} (T_r - T_s) \quad (1)$$

where  $P$  [kW] is the thermal power,  $\dot{m}_w$  [kg/s] is the water mass flow rate,  $C_{p_w}$  is the specific heat of water (4.0 kJ/kg.K for a mixture of 75% water and 25% glycol),  $T_r$  [°C] and  $T_s$  [°C] are the temperatures of the return and supply water flows. The water mass flow was calculated from measurements of the pressure drop over the balancing valves according to,

$$\dot{m}_w = \frac{K_v}{36} \sqrt{\Delta P} \quad (2)$$

where  $\dot{m}_w$  is the water flow [kg/s],  $K_v$  is the coefficient of flow (from manufacturer's tables),  $\Delta P$  is the pressure drop over the balancing valve [kPa]. The pressure drop was measured using TA Hydraulics' TA Link (see Fig. 2) with an inaccuracy of < 1 kPa and measuring range of 0–100 kPa.

Grant thermistors measured the temperatures of the supply and return water flows of the coils with an accuracy of  $\pm 0.1$  °C. The

**Table 2**  
T and RH settings of the tested indoor climate strategies.

	Reference	Class AA	Class A
$T$ [°C]	21	20–22 <sup>a</sup>	20–22 <sup>a</sup>
RH [%]	50	45–55	40–60

<sup>a</sup> Adjusted to 19–21 °C in winter and 21–23 °C in summer.

measuring tips were positioned at the external surface of the piping, directly under the insulation material.

The electric power consumption of the fan and steam humidifier was measured using the ND Metering Solutions, Rail 350 (see Fig. 2) with a resolution of 10 pulses/kWh.

A Grant dataTaker<sup>®</sup> DT85 logged measurement data of the AHU at an interval of 30 s. The data were sent via File Transfer Protocol once a day to a server located at the University.

#### 3.2. Testing ASHRAE's museum climate classes

Table 1 shows T and RH specifications for collections according to ASHRAE [3]. It defines the short-term (hourly and daily) and long-term (seasonal) permissible fluctuations for different climate classes. Note that the average setpoints may be the annual averages that the collection has been exposed to, or 21 °C and 50% RH for loan exhibitions. This study uses the latter. Moreover, Class A includes two options: (i) Fluctuations of  $\pm 5\%$  RH and seasonal adjustments of 10% RH up and 10% RH down; (ii) Larger fluctuations of  $\pm 10\%$  RH without seasonal adjustments. This study uses the latter.

Besides collection preservation, the indoor climate in museums must provide thermal comfort to visitors and staff. RH is predominantly determined by collection requirements, whereas T is predominantly determined by thermal comfort requirements [9]. After all, even Class AA allows seasonal T adjustments of 5 K up and 5 K down resulting in a range of 16 °C to 26 °C for loan exhibitions, see Table 1. Therefore, T setpoints during testing of Classes AA and A were chosen in the range of 19–21 °C in winter and gradually adjusted to 21–23 °C in summer to provide thermal comfort for visitors.

Table 2 summarizes T and RH settings of the tested indoor climate strategies, taking into account both collection and comfort requirements. The Reference strategy does not include any explicitly defined fluctuations.

The indoor climate strategies were tested, each for one week, in the following order: Reference, Class AA, Class A, Class AA, Ref-

erence. This sequence was repeated from April 2015 until March 2016. The BMS was used to access the museum's indoor climate control system to implement the strategies on a weekly basis. This control system has been adapted to be able to implement ASHRAE Class AA and Class A.

#### 4. Results

Fig. 3 shows the outdoor T and RH conditions during the measurement campaign at the museum site in Amsterdam. The proximity of the sea results in a temperate climate that is characterized by mild winters and summers. T may rise to 35 °C in summer and drop to –10 °C in winter, but mostly the temperature varies in the range from 0 °C to 30 °C. The largest T and RH fluctuations occur in Spring and Summer.

##### 4.1. Impact on the indoor environment

For classes AA and A, the indoor T and RH do not necessarily exploit the entire range between upper and lower limit on short time scales (over the course of a day or hour). Particularly if thermal and hygric masses of the building and collection are damping fluctuations or internal heat and moisture gains have a significant effect. Fig. 4 shows typical daily courses of T and RH in winter (Fig. 4a,b) and summer (Fig. 4c,d). Permissible ranges of RH were fully exploited over the course of the seasons: Class AA resulted in minimum RH-levels of 45% in winter and maximum RH-levels of 55% in summer; Class A resulted in minimum RH-levels of 40% in winter and maximum RH-levels of 60% in summer. Permissible ranges of T were almost fully exploited over the course of the seasons (19–23 °C), but temperature was only incidentally lower than 20 °C due to the high insulation level of the museum's envelope and high internal heat gains.

Analyzing the courses of T and RH during a day reveals that short-term fluctuations were limited. The thermal and hygric masses of the building and collection, the latter was rather limited, effectively damped short-term fluctuations. Moreover, free-floating of T and RH in-between the lower and upper limits occurred much more frequently by applying a range of permissible T and RH, particularly during mild outdoor conditions. For temperate climates, this includes spring, autumn and parts of the winter and summer seasons.

Fig. 4c shows the free-floating effect of temperature of classes AA and A in summer: The lighting systems were turned on at 7 h resulting in the first internal heat gains, and from 10 h visitors entered the exhibition hall increasing temperature even more. The maximum temperature, approximately 23.5 °C, was reached around 16 h when most visitors already had left the museum. So, internal heat gains have been exploited much more effectively during winter by applying classes AA and A.

Although the reference strategy does not include permissible fluctuations, Fig. 4 shows that some hourly fluctuations occurred: The indoor climate was more stable in the night and early morning compared to the indoor climate after 7 h. The hourly fluctuations between 7 h and 10 h were induced by the AHU system that conditioned the air to mitigate the effects of internal heat by the lighting systems and interzonal airflow resulting from opening the fire protection doors. The latter was limited by the air curtain, but did have a significant effect. After 10 h, the additional effect of heat and moisture loads by visitors was significant.

The Climate Evaluation Chart (CEC) enables deeper analysis of the effect of the permissible T and RH ranges on the indoor climate's fluctuations, see Figs. 5–7. The bar plots on the right side show the mean hourly and mean daily fluctuations of T and RH. The lower error bars represent the 15.87th percentile and the upper error bars

represent the 84.13th percentile. Thus, the error bars cover 68.26% of the data, equivalent to  $\pm$ SD for normally distributed data.

Fig. 5 shows the CEC of the indoor climate during testing of the Reference strategy. All measurement data are concentrated around 21 °C and 50% RH, i.e. the setpoints. Maximum hourly fluctuations occurred in spring and summer (<0.4 °C and <2.4% RH), whereas daily fluctuations were most prominent in spring (<1.6 °C and <7% RH).

Fig. 6 shows the CEC of the indoor climate during testing of ASHRAE Class AA. The measurement data show a larger seasonal variation of T and RH. Maximum hourly fluctuations occurred in spring (<0.3 °C and <1.2% RH). Daily fluctuations of temperature were most prominent in winter (<1.8 °C), and daily fluctuations of RH were most prominent in spring (<8.2% RH). Comparing Class AA to the Reference strategy results in the following findings per season. Temperature fluctuations increased in winter, particularly daily fluctuations (0.8 => 1.8): The temperature bandwidth was exploited most effectively in winter, i.e. cooling down at night and heating up during the day due to heat gains by visitors and lighting. Spring shows slightly increased daily RH fluctuations and significantly decreased hourly RH fluctuations: The RH bandwidth was exploited effectively as spring is a rather humid season in The Netherlands. So, RH frequently remained close to maximum levels with incidental excursions to lower RH levels. Summer shows significantly decreased hourly T fluctuations, daily T fluctuations, and hourly RH fluctuations. Daily RH fluctuations decreased only slightly. In summer, T and RH frequently remained close to maximum levels, with only little excursions to lower values. Hourly fluctuations decreased mostly because of less frequent dehumidification. In autumn, hourly RH fluctuations decreased significantly; other fluctuations remained almost unchanged. Hourly fluctuations decreased because of fewer interventions by the AHU-systems since free-floating of RH frequently occurred in autumn, only incidentally reaching maximum RH levels.

Fig. 7 shows the CEC of the indoor climate during testing of ASHRAE Class A. The measurement data show again a larger variation among seasons. Maximum hourly fluctuations of temperature occurred in winter and autumn (<0.3 °C) and hourly fluctuations of RH were nearly identical for all seasons (<1% RH). Daily fluctuations of temperature were most prominent in winter (<1.7 °C), and daily fluctuations of RH were most prominent in spring (<7% RH). Comparing Class A to Class AA shows very similar results: Daily RH fluctuations have slightly increased in all seasons, particularly in summer and autumn; Hourly RH fluctuations have decreased even more in spring.

##### 4.2. Impact on energy demand

Besides the impact of ASHRAE's classes AA and A on the museum's indoor environment, the impact on the annual energy demand was assessed. Fig. 8a shows the relative energy consumption of ASHRAE's classes AA and A compared to the Reference strategy: Class AA saved 49% and Class A saved 63% compared to the Reference strategy.

Fig. 8b shows the specific annual energy consumption per square meter of the museum to further investigate these energy savings. Particularly, the results show that relaxing the indoor climate specifications has resulted in significant energy savings for dehumidification. Note that dehumidification was realized by deep cooling. Heating energy has been reduced significantly too, because the Reference strategy required heating predominantly for post-heating the air after dehumidification. On the other hand, this reduction of dehumidification energy (deep-cooling) has resulted in increased energy demand for sensible cooling. Steam humidification already represented a small share of the total energy demand of the Reference strategy, but even proved to be unnecessary

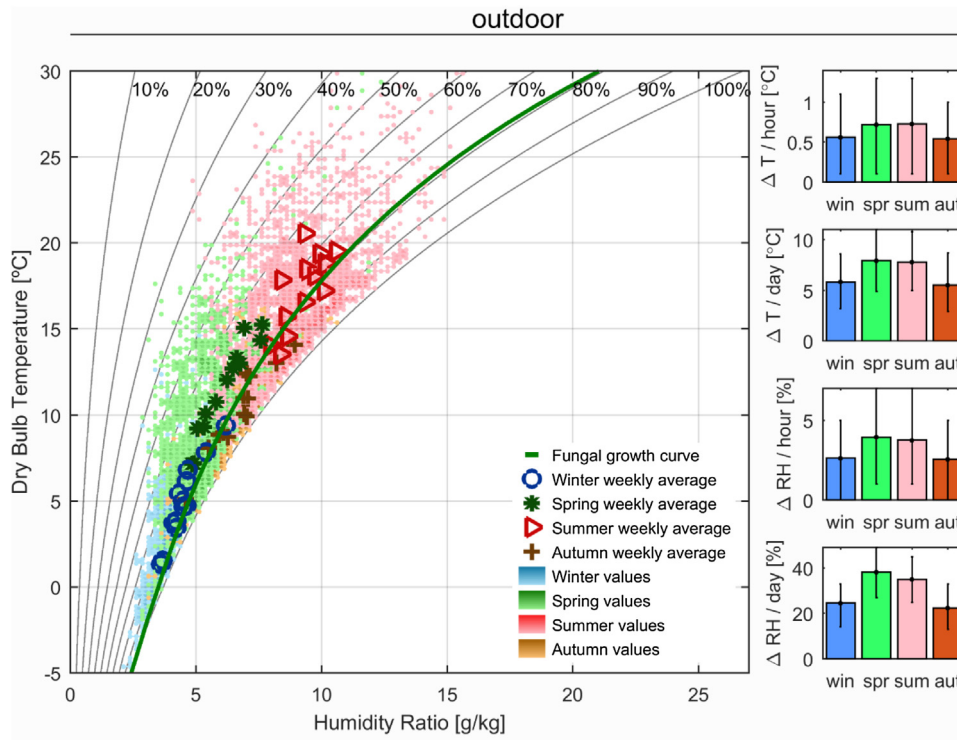

Fig. 3. Outdoor T and RH during the measurements. The bar plots show the mean hourly and daily fluctuations of T and RH. The error bars include 68.2% of data.

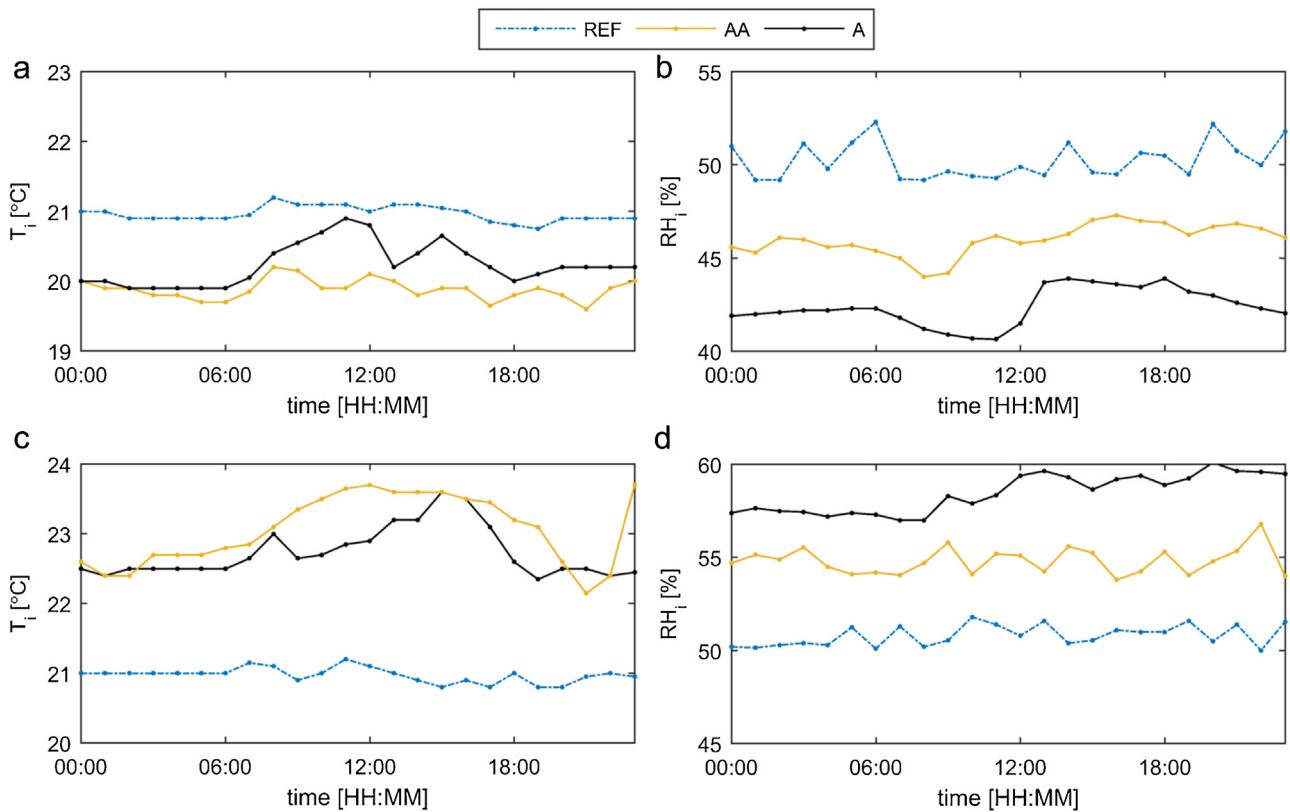
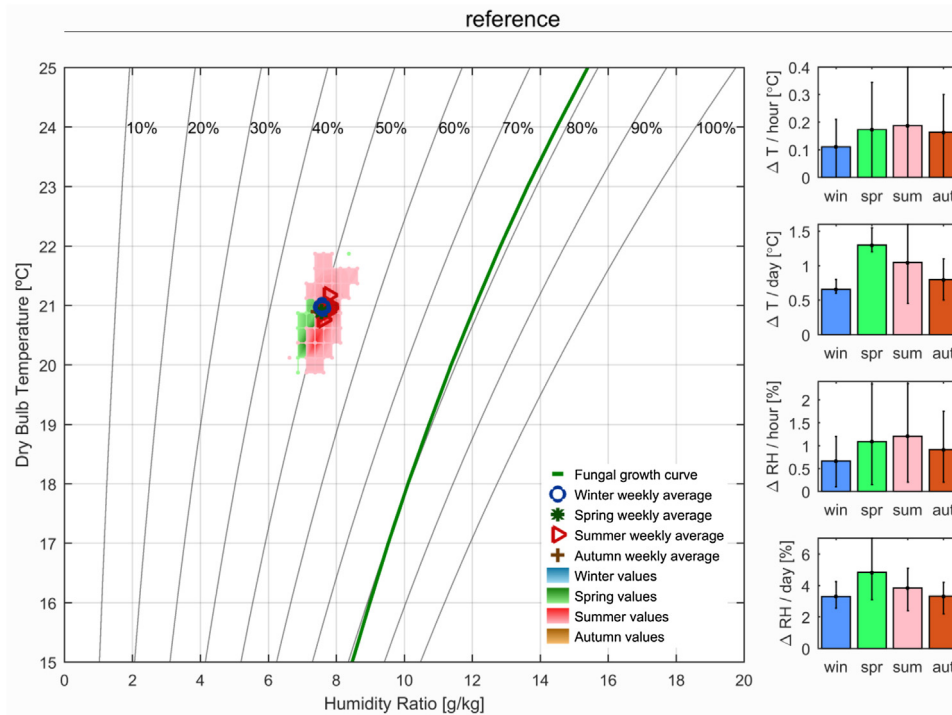

Fig. 4. Typical daily course in winter of T (a) and RH (b), and in summer of T (c) and RH (d).

for Class A. The total energy consumption may be reduced from 1053 kWh/m<sup>2</sup>y (REF) to 385 kWh/m<sup>2</sup>y (Class A).

### 5. Discussion and conclusions

Both T and RH influence degradation processes of artefacts. Chemical degradation is predominantly affected by high levels of T



**Fig. 5.** Indoor climate conditions during testing of the Reference strategy. The bar plots show the mean hourly and daily fluctuations of T and RH. The error bars include 68.2% of data.

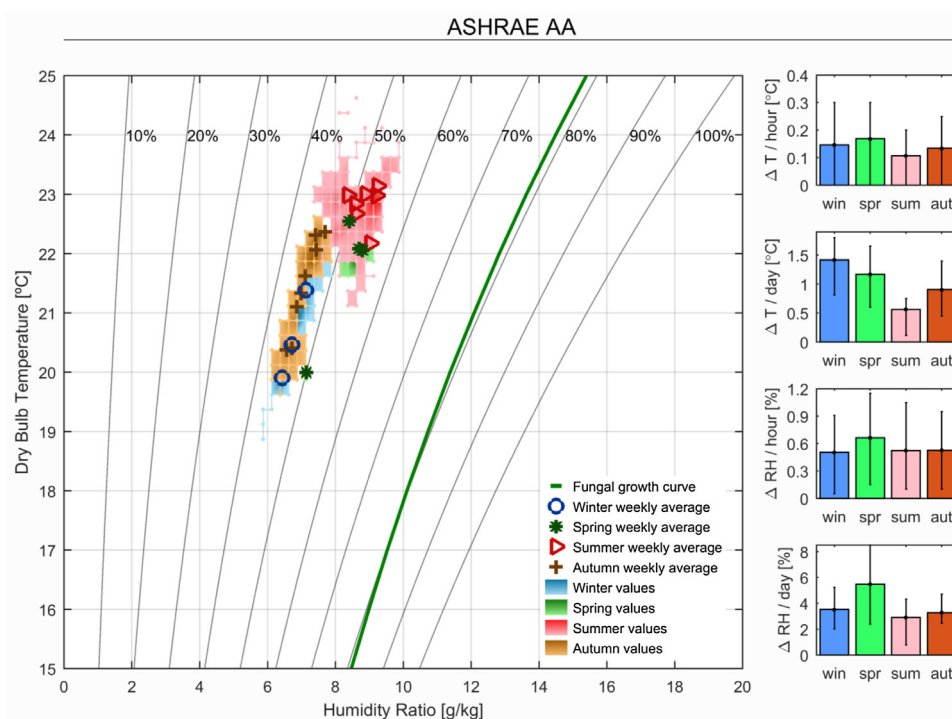

**Fig. 6.** Indoor climate conditions during testing of ASHRAE Class AA. The bar plots show the mean hourly and daily fluctuations of T and RH. The error bars include 68.2% of data.

and, to a lesser extent, high levels of RH [12]. The risk of chemical degradation will be unchanged in the case study museum as long as lower winter temperatures compensate higher summer temperatures [12]. Whether lower winter temperatures are feasible depends on the location of the museum (outdoor climate), the insulation level, and internal heat gains. Because of the high insulation

level and high internal heat gains, the museum in this case study did not cool down significantly in winter; Also in winter, the museum required much cooling due to high internal heat gains. However, because the indoor temperature did not exceed 23 °C for longer periods, the risk of chemical degradation may still be regarded as

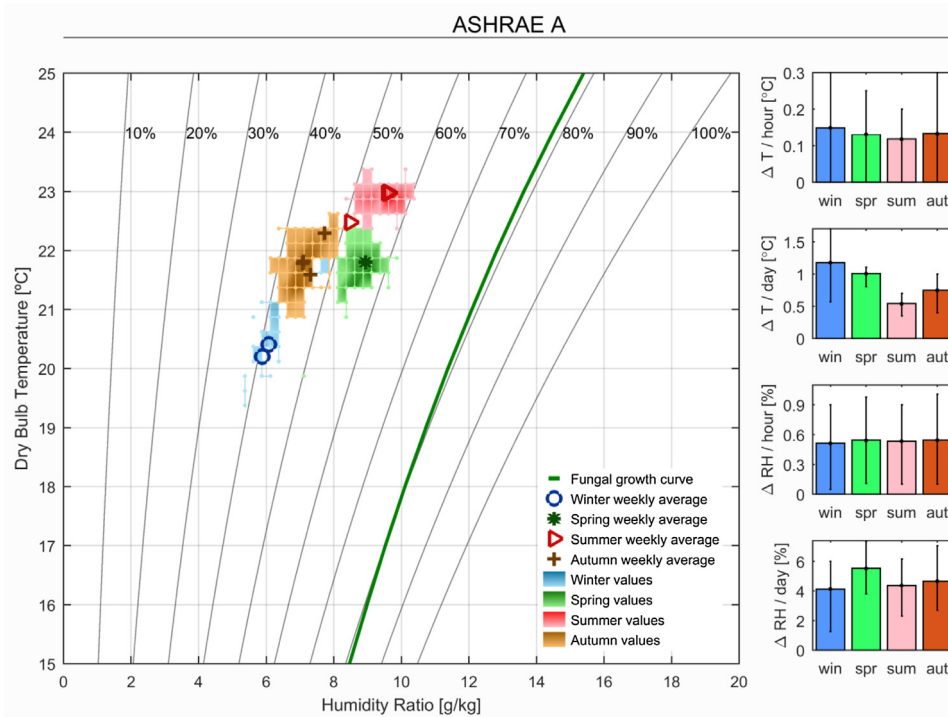

Fig. 7. Indoor climate conditions during testing of ASHRAE Class A. The bar plots show the mean hourly and daily fluctuations of T and RH. The error bars include 68.2% of data.

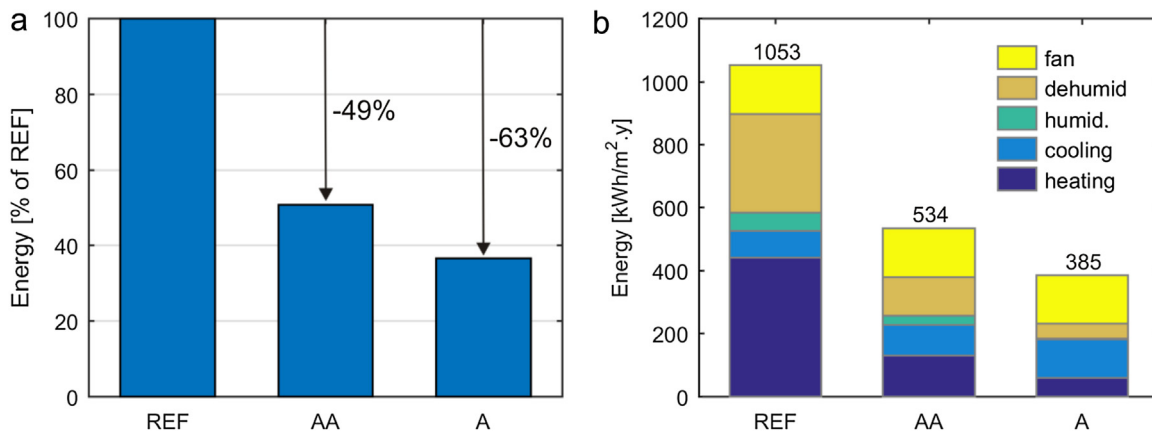

Fig. 8. a) Energy consumption of ASHRAE classes AA and A compared to the Reference strategy (including fan energy). b) Annual energy consumption per square meter specified for heating, cooling, humidification, dehumidification, and fan.

acceptable, but the issue of elevated temperatures for long periods of time requires caution.

Biological degradation, i.e. mold growth, appears at high levels of RH, but may flourish well at a broad range of T [13,14]. Biological degradation will not be an issue since RH has not exceeded 60% and remained far below the critical level of 79%, as illustrated by the Adan mold growth curve in the CECs (Figs. 5–7).

Mechanical degradation is predominantly affected by fluctuations of RH and, to a lesser extent, fluctuations of T [15]. Regarding mechanical degradation, the collection will benefit from smaller and less frequent short-term fluctuations associated with classes AA and A. On the other hand, the effect of slightly increased daily fluctuations may imply an increased risk of mechanical degradation. Experiments have indicated that dimensional changes of wooden objects, determining the risk of mechanical degradation, may not be directly related to daily RH fluctuations [16]. Moreover, it is known that many objects withstand fairly large RH-fluctuations

in the mid-range (40–60% RH) [17]. Experiments have shown that starting at 50% RH, variations may be as high as 41% for the lacquer and 25% for the wood of the Japanese Mazarin Chest [18]. Starting at 90% RH, the risk of damage appeared at a decrease of 13% RH for the lacquer and 16% RH for the wood [18]. The maximum measured daily RH fluctuations in this study are well below these critical values.

The results clearly demonstrated the significant energy saving effect of relaxing the indoor climate conditions for T and RH. However, Fig. 8a implies the law of diminishing returns. This effect has been identified earlier by Mecklenburg (published in [19]) who concluded, based on measurements at several buildings of the Smithsonian Institute, that energy consumption as a function of permissible RH fluctuation follows an exponential decay curve. I.e. switching from a very strict setpoint strategy to Class AA ( $\pm 5\%$  RH fluctuation) saved more energy than switching from Class AA to A ( $\pm 10\%$  RH). In this respect, the results of this study comply with ear-



lier results. However, in this study both T and RH were controlled less strict, whereas the study of Mecklenburg only takes relaxing RH setpoints into account.

The results in Fig. 8a show that relative energy savings are high. The Hermitage Amsterdam may be characterized as an airtight and well-insulated building type, or building type V according to [3]. Kramer et al. [20] have shown in a simulation study that relaxing the indoor climate specifications will relatively save most energy in museums with modern building envelopes, e.g. the museum in this case study, but absolute savings will be the highest in museums with poor building envelopes, e.g. museums housed in historical buildings. The high relative savings in this study appear to comply with results from earlier studies, given the high-quality envelope of the case study museum. Currently, a similar study is carried out in a museum with a historical envelope that has not been refurbished to answer the question how the quality of the building envelope will affect the results.

Further research is required to study the effects of Class A with seasonal adjustments (40% RH  $\pm$  5% RH in winter and 60%  $\pm$  5% RH in summer) besides the tested Class A without seasonal adjustment (50% RH  $\pm$  10% RH). However, this was considered a bridge too far for this case study, as associated degradation risks were considered to be unacceptable by the museum staff. Moreover, comfort requirements are only applicable during opening hours, whereas collection requirements determine temperature setpoints during closing hours. However, in this study, temperature setpoints were determined by comfort requirements 24 h per day, due to the inflexibility of the control system to differentiate between opening and closing hours. Moreover, fluctuations induced by the transition from closing to opening hours should be monitored intensively and controlled.

The main conclusions of this study are:

- Relaxing the museum's indoor climate specifications (T & RH) has resulted in significant energy savings. Class AA saved 49% and Class A saved 63% compared to the current strict indoor climate in this case study.
- Highest energy savings have resulted from decreased dehumidification demand, as less dehumidification has resulted in less deep-cooling and less post-heating.
- Relaxing the indoor climate has resulted in decreased hourly fluctuations and increased daily fluctuations; The museum's hygrothermal mass limited fluctuations.
- It is highly likely that the overall degradation risk has not significantly changed for most artefacts; As RH remained in the mid-range, the influence of slightly larger daily fluctuations may be negligible for most objects. Very sensitive objects may be placed in display cases.

## Acknowledgements

We thank the Building Physics and Services Laboratory of the Eindhoven University of Technology for their efforts regarding the

experimental setup. Moreover, we thank Antony Schellevis and Sebastiaan Lagendaal of museum Hermitage Amsterdam for their confidence and cooperation.

## References

- [1] G. Thomson, Second ed., in: *The Museum Environment*, Butterworth-Heinemann, London, 1986.
- [2] B. Ankersmit, *Klimaatwerk: Richtlijnen voor het museale binnenklimaat*, Amsterdam University Press, Amsterdam, 2009.
- [3] ASHRAE, Museums, libraries and archives, in: ASHRAE Handb. Heating, Vent. Air Cond. Appl., SI edition, 2011, pp. 23.1–23. 23.
- [4] S. Michalski, The ideal climate, risk management, the ashrae chapter, proofed fluctuations, and toward a full risk analysis model, in: *Contrib. to Expert. Roundtable Sustain. Clim. Manag. Strateg.*, Getty Conservation Institute, Tenerife, Spain, 2007, pp. 1–19.
- [5] J.P. Brown, W.B. Rose, Humidity and moisture in historic buildings: the origins of building and object conservation, *APT Bull.* 27 (1996) 12–24.
- [6] M.H.J. Martens, *Climate Risk Assessment In Museums: Degradation Risks Determined from Temperature and Relative Humidity Data*, Eindhoven University of Technology, 2012.
- [7] M. Rota, S.P. Corgnati, L. Di Corato, The museum in historical buildings: energy and Systems. The project of the Fondazione Musei Senesi, *Energy Build.* 95 (2015) 138–143, <http://dx.doi.org/10.1016/j.enbuild.2014.11.008>.
- [8] F. Ascione, L. Bellia, A. Capozzoli, F. Minichiello, Energy saving strategies in air-conditioning for museums, *Appl. Therm. Eng.* 29 (2009) 676–686, <http://dx.doi.org/10.1016/j.applthermaleng.2008.03.040>.
- [9] R. Kramer, M. Maas, M. Martens, A. van Schijndel, H. Schellen, Energy conservation in museums using different setpoint strategies: a case study for a state-of-the-art museum using building simulations, *Appl. Energy* 158 (2015) 446–458, <http://dx.doi.org/10.1016/j.apenergy.2015.08.044>.
- [10] H.F.O. Mueller, Energy efficient museum buildings, *Renew. Energy* 49 (2013) 232–236, <http://dx.doi.org/10.1016/j.renene.2012.01.025>.
- [11] M.P.E. Maas, *Optimizing Climate Control Systems for Museums*, University of Technology Eindhoven, 2012.
- [12] S. Michalski, Double the life for each five-degree drop, more than double the life for each halving of relative humidity, in: R. Vontobel (Ed.), *13th Trienn. Meet. Rio Janeiro*, James & James, London, 2002, pp. 66–72.
- [13] S. Guild, M. MacDonald, Mould prevention and collection recovery, *Technol. Bull.* 26 (2004).
- [14] K. Sedlbauer, *Prediction of Mould Fungus Formation on the Surface of and Inside Building Components*, Fraunhofer Institute for Building Physics, 2001.
- [15] M.F. Mecklenburg, C.S. Tumosa, Mechanical behaviour of paintings subjected to changes in temperature and relative humidity, *Art Transit Stud Transp. Paint.*, National Gallery of Art 1991 (2016) 173–216.
- [16] J. Ashley-Smith, N. Umney, D. Ford, Let's be honest: realistic environmental parameters for loaned objects, in: *Prev Conserv. Pract. Theory Res.*, IIC, Ottawa, 1994.
- [17] S. Michalski, Relative humidity: a discussion of correct/incorrect values, *ICOM Commun. Conserv.* 2 (1993) 624–629.
- [18] L. Bratasz, R. Kozlowski, A. Kozlowska, S. Rivers, Conservation of the Mazarin Chest: structural response of Japanese lacquer to variations in relative humidity, *ICOM Commun. Conserv.* 2 (2008) 1086–1093.
- [19] D.J. Artigas, *A Comparison of the Efficacy and Costs of Different Approaches to Climate Management in Historic Buildings and Museums*, University of Pennsylvania, 2007.
- [20] R. Kramer, H. Schellen, J. van Schijndel, Energy impact of ASHRAE's museum climate classes: a simulation study on four museums with different quality of envelopes, *Energy Procedia* 78 (2015) 1317–1322, <http://dx.doi.org/10.1016/j.egypro.2015.11.147>.