

STATE-OF-THE-ART PAPER

Diagnostic and Therapeutic Challenges in Patients With Coexistent Chronic Obstructive Pulmonary Disease and Chronic Heart Failure

Thierry H. Le Jemtel, MD,* Margherita Padeletti, MD,† Sanja Jelic, MD†

New Orleans, Louisiana; and New York, New York

Chronic obstructive pulmonary disease (COPD) and heart failure (CHF) are common conditions. The prevalence of COPD ranges from 20% to 30% in patients with CHF. The diagnosis of CHF can remain unsuspected in patients with COPD, because shortness of breath is attributed to COPD. Measurement of plasma B-type natriuretic peptide (BNP) levels helps to uncover unsuspected CHF in patients with COPD and clinical deterioration. Noninvasive assessment of cardiac function may be preferable to BNP to uncover unsuspected left ventricular (LV) systolic dysfunction in patients with stable COPD. Patients with COPD or CHF develop skeletal muscle alterations that are strikingly similar. Functional intolerance correlates with severity of skeletal muscle alterations but not with severity of pulmonary or cardiac impairment in COPD and CHF, respectively. Improvement of pulmonary or cardiac function does not translate into relief of functional intolerance in patients with COPD or CHF unless skeletal muscle alterations concomitantly regress. The mechanisms responsible for skeletal muscle alterations are incompletely understood in COPD and in CHF. Disuse and low-level systemic inflammation leading to protein synthesis/degradation imbalance are likely to contribute. The presence of COPD impacts on the treatment of CHF, as COPD is still viewed as a contraindication to beta-blockade. Therefore, COPD often deprives patients with CHF due to LV systolic dysfunction of the most beneficial pharmacologic intervention. A large body of data indicates that patients with COPD tolerate well selective beta-blockade that should not be denied to CHF patients with concomitant COPD. (J Am Coll Cardiol 2007;49:171–80) © 2007 by the American College of Cardiology Foundation

Chronic heart failure (CHF) and chronic obstructive pulmonary disease (COPD) are 2 commonly encountered conditions in clinical practice: 14 million Americans have COPD and 5 million have CHF (1,2). Notwithstanding the use of tobacco as a common risk factor, the sheer number of patients with COPD and CHF accounts for their frequent coexistence. Among the comorbid conditions commonly associated with CHF, COPD is the one that most delays the diagnosis of CHF and is most often advocated for nonadherence to therapeutic guidelines, especially beta-blockade (BB) (3). The present review aims to address the diagnostic and therapeutic problems raised by the coexistence of COPD and CHF. The first aim of the review is to outline why COPD delays the diagnosis of CHF and how to avoid any diagnostic delay. The second aim is to emphasize the important role of skeletal muscle alterations in limiting functional capacity in patients with COPD and in patients with CHF and to advocate new therapeutic

interventions to manage skeletal muscle alterations in chronic conditions. The third aim is to summarize the data that demonstrate the safety and efficacy of BB in patients with COPD and to promote a greater use of BB in patients with coexistent COPD and CHF.

Impact of COPD on the Diagnosis of CHF

Overlooked CHF in patients with COPD. Patients without known respiratory disease who complain of dyspnea or fatigue during exercise undergo noninvasive cardiac imaging that establishes the diagnosis of heart failure when it demonstrates left ventricular (LV) dysfunction. When patients with stable COPD complain of dyspnea or fatigue during exercise, these symptoms are often attributed to COPD, noninvasive cardiac imaging is not performed, and LV dysfunction remains undetected (4). In all studies but 1, the prevalence of COPD ranges from 20% to 32% in patients with CHF (4–11). The outlier study reported a 10% prevalence of COPD in patients hospitalized for CHF (10). The risk ratio of developing CHF is 4.5 (95% confidence interval [CI] 4.25 to 4.95) in COPD patients compared with age-matched controls without COPD after adjustments for cardiovascular risk factors (12). The rate-

From the *Division of Cardiology, Tulane University, New Orleans, Louisiana; and the †Division of Pulmonary, Allergy, and Critical Care Medicine, Columbia University College of Physicians and Surgeons, New York, New York.

Manuscript received June 19, 2006; revised manuscript received August 14, 2006, accepted August 14, 2006.

Abbreviations and Acronyms

- ACE** = angiotensin-converting enzyme
- BB** = beta-blockade
- BNP** = B-type natriuretic peptide
- CHF** = chronic heart failure
- CI** = confidence interval
- COPD** = chronic obstructive pulmonary disease
- FEV₁** = forced expiratory volume in 1 s
- LV** = left ventricular
- SM** = skeletal muscle

adjusted hospital prevalence of CHF is 3 times greater among patients discharged with a diagnosis of COPD compared with patients discharged without mention of COPD (13). Furthermore, the prevalence of hospitalization for CHF increased at a much higher rate from 1971 to 2001 when discharge coding included COPD as primary or secondary diagnosis than when COPD was not mentioned as a diagnosis (13). The Northern California Kaiser Permanente Medical Program has reported an age-adjusted relative rate of hospitalization for CHF of 5.55

(95% CI 4.71 to 5.73) and an odds ratio of CHF as a comorbidity of 8.48 (95% CI 7.65 to 9.40) in COPD patients compared with controls (14).

COPD as a cardiovascular risk. The high prevalence of CHF in patients with COPD is not surprising, because COPD patients are at increased risk of cardiovascular mortality or morbidity independently of other risk factors, including tobacco use. Forced expiratory volume in 1 s (FEV₁) is as good a predictor of cardiovascular mortality as

serum cholesterol (15). Ischemic heart disease, and not respiratory failure, is the leading cause of death in COPD patients, with only a small fraction dying of respiratory failure (16). The relationship between COPD and cardiovascular events remains unclear. Patients with COPD are not at increased risk for hypertension or LV hypertrophy; however, they consistently show evidence of low-grade systemic inflammation that plays an increasingly recognized role in the pathogenesis of atherosclerosis (17). Patients with severe COPD are 2.18 and 2.74 times more likely to have elevated and highly elevated, respectively, circulating C-reactive protein levels than control subjects (18). A working hypothesis to account for the high prevalence of LV systolic dysfunction in patients with COPD is that low-grade systemic inflammation accelerates progression of coronary atherosclerosis, which ultimately results in ischemic cardiomyopathy. Such a hypothesis fits the clinical observation of a high incidence of LV wall motion abnormalities noted in patients with COPD and LV dysfunction (19).

Uncovering CHF during COPD exacerbation. The diagnostic usefulness of measuring B-type natriuretic peptide (BNP) plasma levels in patients presenting to an emergency room with dyspnea is now well established and was recently reviewed (20-22) (Fig. 1). A BNP level of >500 pg/ml in a patient with known COPD consulting for clinical deterioration alerts to the presence of overt CHF whether or not the patient is known to have CHF. A BNP level of >500

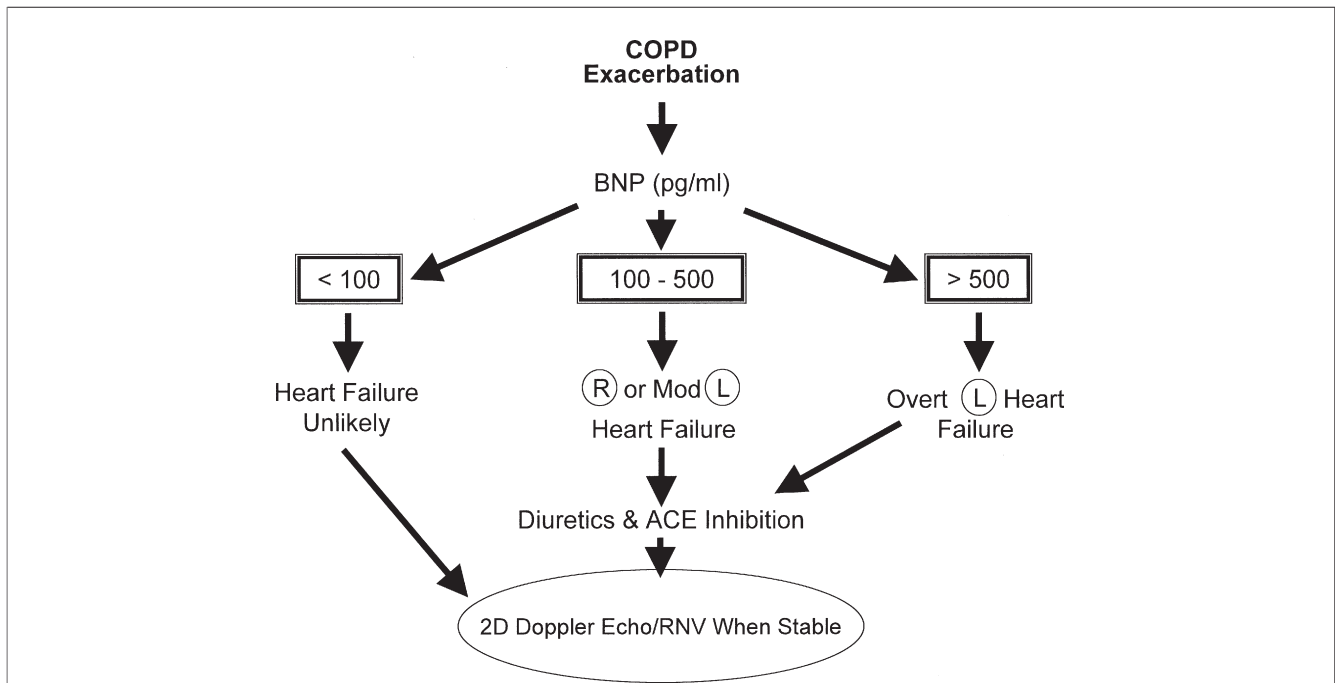
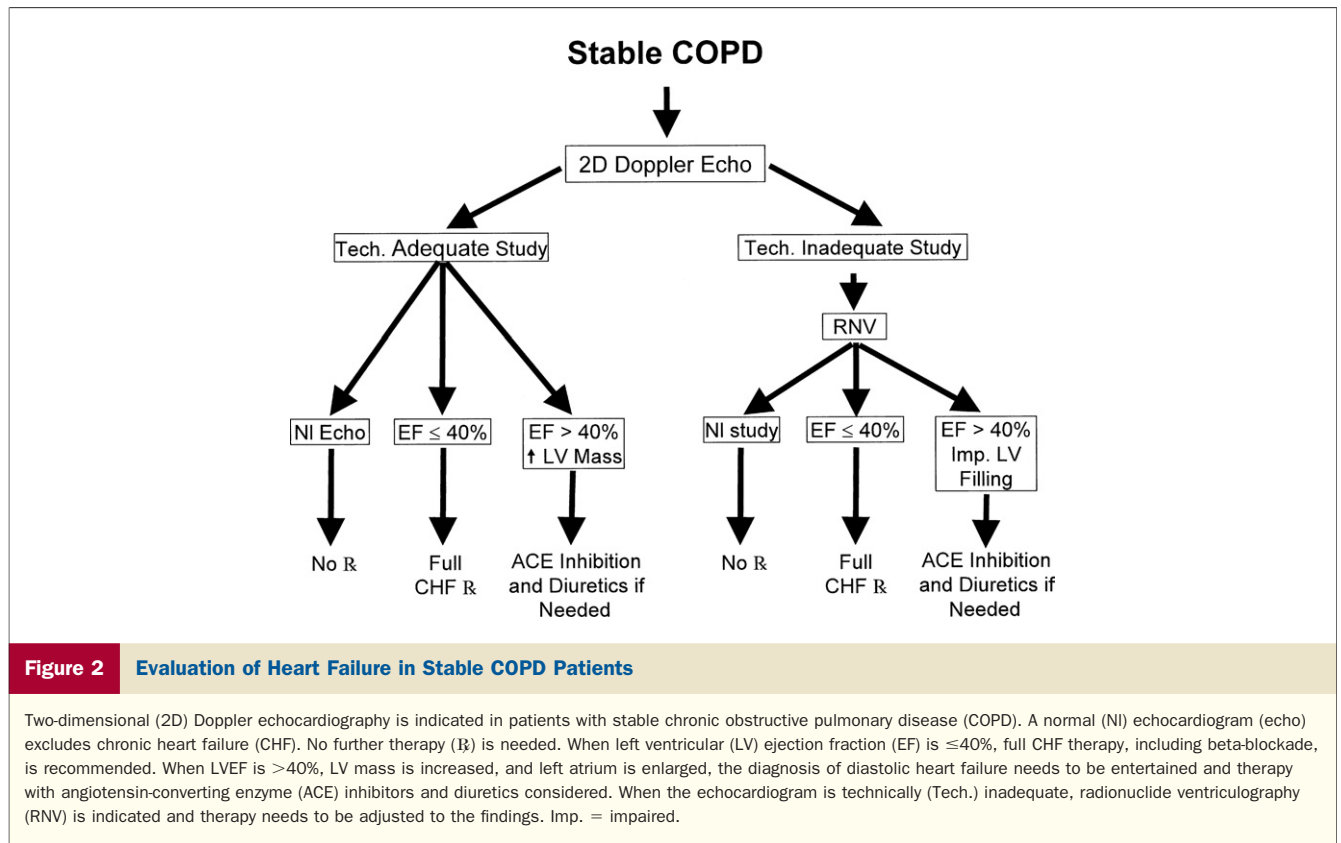

Figure 1 Evaluation of Heart Failure During COPD Exacerbation

Brain natriuretic peptide (BNP) serum levels and detection of chronic heart failure (CHF) in patients with exacerbation of chronic obstructive pulmonary disease (COPD). CHF is unlikely when BNP levels are <100 pg/ml. A BNP level of >500 pg/ml indicates overt left-sided (L) CHF and the need for treatment. BNP levels ranging from 100 to 500 pg/ml indicate right-sided (R) heart failure, moderate left-sided heart failure, or both and the need for treatment. Once patients have returned to baseline status, cardiac imaging needs to be performed and therapy adjusted. 2D = 2-dimensional; ACE = angiotensin-converting enzyme; RNV = radionuclide ventriculography.



pg/ml does not differentiate cardiac from pulmonary deterioration as the cause of clinical worsening but indicates that CHF therapy should be initiated or upgraded in addition to treatment of COPD. In contrast, a BNP level of <100 pg/ml argues against CHF decompensation as the cause of clinical deterioration but does not completely eliminate acute heart failure as the triggering factor of clinical deterioration (A. Maisel, personal communication, July 2006). A BNP level between 100 to 500 pg/ml points toward right ventricular failure, moderate LV failure, or both and the need to initiate therapy with angiotensin-converting enzyme (ACE) inhibitors and possibly loop diuretics. Once patients with COPD exacerbation have returned to their baseline status, cardiac imaging needs to be performed and therapy adjusted according to the findings.

Ascertaining CHF in patients with stable COPD. Because 20% to 25% of ambulatory patients with CHF have BNP levels of <100 pg/ml, echocardiography appears more reliable than BNP levels to detect unsuspected LV systolic dysfunction in patients with stable COPD (23) (Fig. 2). Radionuclide ventriculography (RNV) may be obtained when a poor acoustic window impedes evaluation of LV function by echocardiography in COPD patients.

Patients with COPD found to have an LV ejection fraction of $\leq 40\%$ need to receive full CHF therapy, including beta-adrenergic blockade. Patients with COPD with normal LV ejection fraction and normal LV mass or LV filling do not require CHF therapy. The diagnosis of diastolic heart failure is

particularly difficult to establish in patients with COPD. The diagnosis of diastolic heart failure needs to be entertained in COPD patients with LV ejection fraction $>40\%$ and abnormal LV mass or enlarged left atrium by echocardiography or impaired LV filling by RNV, and the response to ACE inhibitors and loop diuretics needs to be closely monitored. Standard echocardiographic indices of LV diastolic dysfunction do not reliably permit the diagnosis of diastolic heart failure, but the diagnosis can be established by comprehensive Doppler echocardiography and myocardial tissue imaging, which provide evidence for impaired myocardial relaxation, decreased LV compliance, and increased LV filling pressure (24,25).

In summary, COPD is an important risk factor for cardiovascular morbidity and mortality in the general population. Chronic heart failure is often unrecognized despite its high prevalence in COPD patients. Elevated BNP plasma levels should alert to the presence of CHF in patients with COPD exacerbation. The 20% to 30% prevalence of CHF in ambulatory patients with stable COPD mandates noninvasive assessment of LV function to avoid undue delays in the diagnosis and therapy of previously unrecognized CHF.

Skeletal Muscle Alterations in Patients With CHF and COPD

Although CHF and COPD primarily involve different organs, patients with CHF and COPD develop strikingly

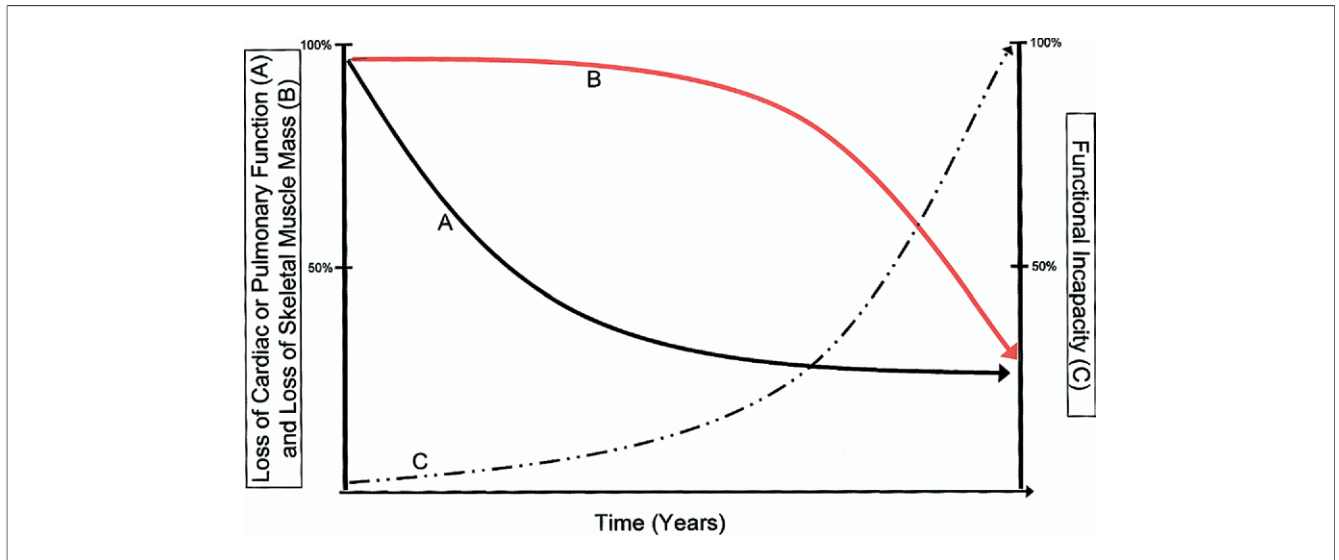

Figure 3 Progression of CHF and COPD

Time course of loss of cardiac or pulmonary function (A), loss of skeletal muscle mass (B), and functional incapacity (C) during the progression of chronic heart failure (CHF) or chronic obstructive pulmonary disease (COPD). **Curves A and C** in CHF patients are based on data collected during studies of left ventricular dysfunction (101). **Curve B** in CHF patients and **curves A, B, and C** in COPD patients are based on clinical experience in the absence of quantitative data.

similar skeletal muscle (SM) alterations (26,27). In brief, SM alterations in CHF and COPD include decreased muscle strength and mass with reduced cross-sectional area, fiber shift with atrophy of type I oxidative fibers, and relative increase in glycolytic type IIa and IIb fibers accompanied by an increase in glycolytic and a decrease in oxidative enzymatic activities (27–29). Whether the enzymatic alterations are the cause or consequence of the fiber shift remains to be determined. Use of ³¹P nuclear magnetic resonance spectroscopy has demonstrated reduced concentration of high-energy phosphate at rest, which becomes more pronounced during exercise with a faster drop in pH and a slower rephosphorylation after exercise in patients with CHF or COPD compared with age-matched controls (27). Loss of SM mass and the resulting muscle atrophy have major clinical and therapeutic implications in CHF and COPD. **SM atrophy in CHF and COPD.** Muscle atrophy contributes to muscle fatigue during exercise, which leads patients with CHF or COPD to discontinue exercising although they have not exhausted their cardiac or pulmonary reserve (30,31). Peak oxygen uptake is linearly related to SM mass in patients with CHF and or COPD (32–34). As the disease progresses, SM atrophy worsens and patients with CHF or COPD become increasingly symptomatic (Fig. 3). Therapeutic interventions that improve LV and pulmonary function in patients with CHF and COPD, respectively, do not reliably reverse SM atrophy and thus do not consistently alleviate functional intolerance (35,36). Therefore, interventions that primarily aim at reversing SM atrophy are needed to complement existing interventions that improve cardiac and pulmonary function in patients with CHF and COPD, respectively.

Mechanisms of SM atrophy in CHF or COPD. The events and mechanisms that lead to SM atrophy are incompletely understood in patients with CHF and COPD. Muscle disuse, low-level systemic inflammation, and increased oxidative stress contribute to reduced protein synthesis and accelerated protein degradation and thus to SM atrophy (37) (Fig 4). Muscle disuse evolves as dyspnea and fatigue prompt patients to progressively avoid all physical activities. Patients are often unaware of the progressive decline in physical activities, which is not readily quantifi-

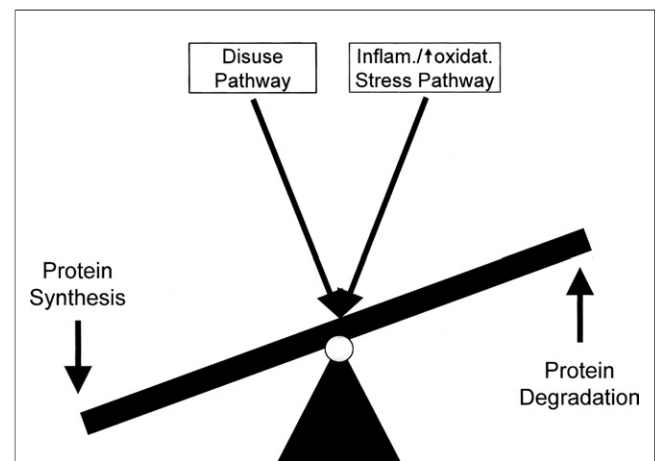

Figure 4 Mechanisms of Skeletal Muscle Atrophy in Patients With CHF or COPD

Disuse, low-level systemic inflammation (Inflam.), and increased oxidative (oxidat.) stress decrease protein synthesis while increasing protein degradation. CHF = chronic heart failure; COPD = chronic obstructive pulmonary disease.

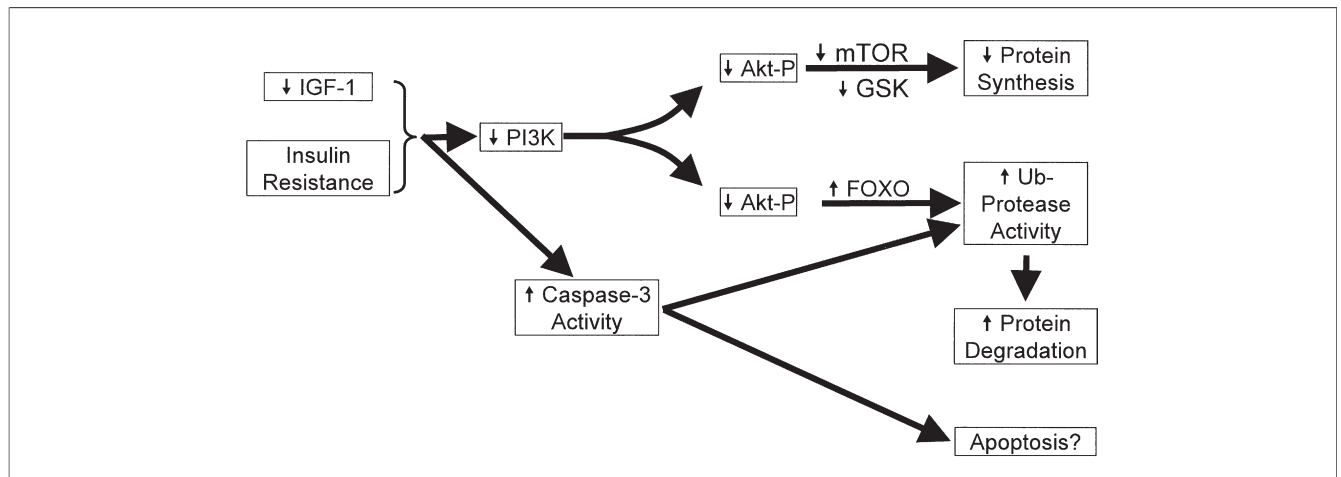

Figure 5 Signaling Pathways of Disuse and Inflammation

Reduced insulin growth factor-1 (IGF-1) tissue level and insulin resistance combine to decrease phosphorylation of phosphatidylinositol-2-OH kinase (PI3K), which in turn reduces activation of Akt (protein kinase B), thereby reducing protein synthesis via reduced phosphorylation of mammalian target of rapamycin (mTOR) and glucogen synthase kinase (GSK). Reduced Akt activation increases activity of forkhead box O (FOXO) transcription factors, thereby activating the ubiquitin-proteasome pathway and promoting protein degradation. Reduced IGF-1 levels and insulin resistance activate caspase-3, resulting in protein breakdown and degradation. Whether activated caspase-3 results in muscle apoptosis is controversial.

able. However, the overt benefits of a rigorous training program corroborate the importance of disuse as a cause of SM atrophy in patients with CHF or COPD (38,39). Besides SM disuse, low-level systemic inflammation and increased oxidative stress are responsible for SM atrophy in CHF and COPD. Circulating levels of proinflammatory cytokines are elevated in patients with CHF and COPD, and 8-isoprostanes are elevated in the pericardial fluid of patients with CHF (40,41). The source of systemic inflammation appears to be in the small airways in COPD and is unclear in CHF (42,43).

Signaling pathways of disuse and inflammation. Both disuse and inflammations set off SM atrophy by reducing protein synthesis, increasing protein degradation, or both (44) (Fig. 4). Reduced protein synthesis and increased protein degradation share common pathways (37). Insulin resistance and reduced tissue concentration of insulin growth factor (IGF)-1 reduce phosphorylation of the phosphatidylinositol-3-OH kinase, which in turn lowers activation of Akt (protein kinase B), thereby decreasing protein synthesis via dephosphorylation of mTOR, a mammalian target of rapamycin and glucogen synthase kinase (45–49) (Fig. 5). Reduced Akt activation increases activity of forkhead box O (FOXO) transcription factors, which in turn activates the ubiquitin-proteasome pathway, resulting in protein degradation (48–52) (Fig. 5). In addition, insulin resistance and reduced tissue IGF-1 concentration activate caspase-3 (53). After cleavage by activated caspase-3, myofibrillar proteins are degraded by the ubiquitin-proteasome pathway (54). Whether apoptosis plays a significant role in SM atrophy remains controversial (55,56). The important role that the growth hormone (GH)/IGF-1 axis plays in mediating SM growth provides the rationale for the use of

ghrelin in patients with CHF or COPD (57). Ghrelin, a novel GH-releasing peptide acts through a mechanism that is more potent and independent of hypothalamic GH-releasing hormone (58). Administration of ghrelin for 3 weeks improves functional capacity and alleviates SM atrophy in patients with CHF and in patients with COPD (59,60).

In summary, disuse, low-level systemic inflammation, and increased oxidative stress contribute to SM atrophy by enhancing protein degradation and hindering protein synthesis. Reduced IGF-1 muscle concentration provides the rationale for modulation of the GH/IGF-1 axis. Preliminary results with ghrelin, a novel modulator of the GH/IGF-1 axis, are encouraging.

Emerging therapeutic approaches in CHF and COPD. Since it was shown to lower mortality 2 decades ago, ACE inhibition has been the cornerstone of treatment of CHF (61). More recently, ACE inhibition was shown to prevent cachexia and SM atrophy and to improve respiratory muscle strength in patients with CHF (62–64). Because the beneficial effects of ACE inhibition on muscles are partially mediated by a reduction in angiotensin II levels, which in turn attenuates the decline in IGF-1 levels, achieving complete ACE inhibition may be of special interest to prevent SM atrophy in CHF and potentially in COPD (65). Modulation of the renin-angiotensin system with ACE inhibition or angiotensin receptor blockade (ARB) may have dual benefits in patients with COPD by lowering cardiovascular risk and preventing lung injury (66,67). However, ARB failed to improve respiratory or SM strength in patients with COPD without cardiovascular diseases nor the exercise capacity or dyspnea score in patients with COPD and pulmonary hypertension (68,69).

When they receive ACE inhibitors, patients with COPD are not at increased risk of cough or bronchospasm (70). Occurrence of cough in patients with COPD is more likely to be related to unsuspected CHF than to ACE inhibition.

Human menopausal gonadotropin-CoA reductase inhibition with simvastatin inhibits development of emphysema, inflammation, and pulmonary hypertension in a rat model of smoking-induced lung injury (71). Simvastatin also reverses pulmonary hypertension in a rat model of toxic injury to the pulmonary vasculature (72). The pleiotropic effects and, especially, the anti-inflammatory action of simvastatin are likely to mediate its benefits in experimental models. Administration of simvastatin for 14 weeks improves LV ejection fraction and functional status in patients with CHF due to idiopathic cardiomyopathy (73). These preliminary findings with simvastatin contrast with the negative experience with tumor necrosis factor α antibodies (74,75). A nested case-control study of elderly COPD patients with and without known CAD who were receiving statins, ACE inhibitors, or ARBs alone or a combination of statins with either ACE inhibitors or ARBs advocates that these agents may have cardiopulmonary protective properties (76). Statins alone and in combination with either ACE inhibitors or ARBs reduced hospitalizations for COPD (76). Because only a minority of patients with CHF (<4%) were included in that case-control COPD study, one cannot extrapolate the results to patients with coexistent CHF and COPD. Whether these agents have dual cardiac and pulmonary protective properties needs to be confirmed in randomized clinical trials.

BB in Patients With CHF and COPD

Long-term BB is underused in CHF patients (3,77). Underuse of BB in CHF is largely due to the entrenched belief that it may precipitate respiratory deterioration when COPD coexists with CHF. Few reports of acute bronchospasm after initiation of BB lead to exclusion of patients with coexistent CHF and COPD from large BB trials (78). Beta-blockers remain underprescribed to patients with CHF and COPD despite extensive safety data in patients with moderate to severe COPD (77,79,80).

Selective beta-1 adrenergic blockade. Respiratory symptoms and FEV₁ are not significantly worsened by selective beta-1 blockade (B1B) in COPD patients (80–86). Selective B1B with metoprolol succinate or tartrate was well tolerated for 3 months by 50 patients with coexistent ischemic cardiac disease and mild to severe COPD (87). Patients remained free of adverse respiratory effects, and FEV₁ was unchanged. Selective B1B does not attenuate beta-2 receptor (B2R) agonist-induced bronchodilatation (82). The cumulative evidence from trials and meta-analysis indicates that selective B1B should not be withheld when COPD coexists with cardiovascular diseases, because the benefits of selective B1B in cardiac patients with COPD far outweigh the risks (80,88).

Nonselective BB combined with alpha-blockade. The safety profile of carvedilol and labetalol that combine alpha-adrenergic blockade with nonselective BB is not as well-established as that of selective B1B in COPD. Labetalol at maximal dose does not affect FEV₁ in COPD (79). Among 89 patients with coexistent COPD and CHF who received carvedilol for at least 3 months, only 13 did not tolerate carvedilol (89). The reasons for intolerance and the presence of reversible airway obstruction were not specified. Thirty-one patients with coexistent CHF and COPD without reversible airflow obstruction receiving a mean dose of 29 ± 19 mg daily carvedilol were followed for a mean duration of 2.4 years (90). Only 1 patient did not tolerate carvedilol because of COPD exacerbation. Cardiac size and function improved similarly in patients with coexistent CHF and COPD and in patients with CHF alone after receiving nonselective beta- and alpha-adrenergic blockade for 24 months (89,91). Data regarding the use of carvedilol in COPD patients with reversible airflow obstruction are not available. In contrast to selective B1B, nonselective blockade attenuates B2R agonist-induced bronchodilatation.

Clinical experience with selective B1B and combined nonselective and alpha-blockade in COPD. Beta-blockade with selective and nonselective agents does not affect the rate of hospitalization for COPD exacerbation in patients with recent myocardial infarction, whereas it beneficially impacts mortality (92,93). Although case studies have documented nonselective BB-triggered bronchospasm, BB with selective and nonselective agents does not appear to affect the rate of hospitalization for COPD exacerbation (94). Therefore, current guidelines from the Heart Failure Society of America recommend BB in all patients with coexistent COPD and CHF (88). The use of BB in patients with COPD and CHF can be substantially and safely increased by a structured outpatient program (95). The clinical experience and pulmonary effects of the 3 beta-blockers currently approved for the treatment of CHF are summarized in Table 1.

Lastly, 3 issues regarding BB in COPD patients will be briefly reviewed. They are time dependence of pulmonary effects, receptor selectivity, and concomitant use of BB and beta-2 agonists.

Time dependence of BB-induced pulmonary effects. As observed with LV function, acute and long-term BB appears to have opposite effects on lungs. Airway hyperresponsiveness (AHR), as defined by an FEV₁ decline of $\geq 20\%$ after inhalation of metacholine, is associated with increased mortality in patients with COPD (96). Acutely administered selective or nonselective BB increases AHR in patients with COPD (82). However, after an initial increase, long-term administration of carvedilol or nadolol reduces AHR in a murine model of asthma (97). No data are presently available regarding the effects of long-term BB on AHR in patients. Similarly, beta-receptor (BR) density, although unaffected by acute BB, increases during long-term BB (97). Increased BR density may be beneficial as

Table 1 Effects of Beta-Blockers Approved for Treatment of Heart Failure on Lung Function and Symptoms in Patients With COPD

	Adrenergic Receptor-Blocking Activity	Doses in Heart Failure	Doses Used in Referenced Trials	Long-Term FEV ₁ Treatment Effect in Irreversible Airway Disease	Long-Term FEV ₁ Treatment Effect in Reversible Airway Disease	Respiratory Symptoms	Reference
Bisoprolol	Beta-1	1.25-10 mg daily	20 mg daily	NA	NA	None	86
Metoprolol (Toprol-XL)	Beta-1	12.5-200 mg daily	200 mg daily 100 mg twice daily 100 mg twice daily	NA NA NA	NA Excluded Not specified	1/6 patients None None	81 82 83
			50 mg three times daily 100 mg twice daily	↓ (reversed with beta-agonist), NS ↓ (reversed with beta-agonist)	Not specified Not specified	None None	84 85
Carvedilol	Beta-1 Beta-2 Alpha-1	3.125-25 mg twice daily	29 ± 19 mg daily 12.5-25 mg twice daily	NA NA	Excluded Not specified	1/31 patients 13/89 patients	90 89

FEV₁ = forced expiratory volume in 1 second; NA = not applicable; NS = not significant.

experimental over-expression of B2R increases adenylyl cyclase activity in airway smooth muscle and reduces AHR (98).

In summary, the detrimental effects of acute BB on AHR may with time convert into beneficial effects. Accordingly, early mild deterioration in pulmonary symptoms or FEV₁ in patients with coexistent CHF and COPD should not prompt BB discontinuation. Close observation is recommended and BB discontinuation is warranted when pulmonary symptoms persist or worsen.

Receptor selectivity of BB. Selective B1Bs have a 20-fold higher affinity for B1R than for B2R. Selective B1Bs are presumably less likely to induce bronchoconstriction than nonselective BBs (99). However, the receptor selectivity of BBs varies in experimental models (100). Receptor selectivity varies for the following reasons: 1) B2Rs predominate in bronchial smooth muscle, whereas B1Rs account for 10% and 30% of beta-receptors in submucosal glands and alveolar walls, respectively (101); 2) selective B1Bs appear to lose selectivity at the high end of dose ranging; 3) several polymorphisms of beta-receptor have been reported; and 4) exposure to agonists may alter B2Rs such that the affinity for ligands is reduced 10-fold (102). Consequently, prior exposure to beta agonists may reduce binding of antagonists to B2Rs. It may explain the high tolerance for BB in COPD patients who routinely inhale B2R agonists.

In summary, BB receptor selectivity varies in experimental settings. Whether such variability has therapeutic implications remains unclear in patients with COPD.

Concomitant use of BB and inhaled beta-agonists. Owing to the cardiovascular risks associated with the use of inhaled B2R agonists, nonselective BB may be particularly beneficial in patients with CHF and COPD. Deleterious cardiovascular effects of inhaled B2R agonists, the mainstay of COPD therapy, are now increasingly recognized. Recent meta-analysis of 5 single-dose and 6 longer-duration trials of B2R agonists has underlined their adverse cardiovascular effects in COPD patients (103). Therapy with inhaled B2R agonists is associated with an increased risk for CHF decompensation (adjusted OR 3.42, 95% CI 1.99 to 5.86) and all-cause mortality in patients with CHF (104,105). Inhaled B2R agonists induced adverse cardiac effects in COPD patients with pre-existing cardiovascular disease (106). The adverse effects of B2R agonists are likely to be exacerbated in COPD patients with coexistent CHF. The efficacy of concomitant BB to offset the adverse cardiovascular effects of B2R agonists in COPD patients with coexistent CHF has not yet been assessed in clinical trials.

In summary, BB therapy should be attempted with selective beta-1 adrenergic blockade or combined nonselective beta- and alpha-adrenergic blockade in all CHF patients with concomitant stable COPD who do not have reversible airway obstruction. Selective BB is recommended in patients with CHF and COPD who have reversible airway obstruction in the absence of safety data regarding combined nonselective beta- and alpha-adrenergic blockade. Both selective beta-1 and com-

bined nonselective beta- and alpha-adrenergic blockade are to be avoided during COPD exacerbation until safety data are available.

Reprint requests and correspondence: Dr. Thierry H. Le Jemtel, Section of Cardiology, Department of Medicine, Tulane University School of Medicine, 1430 Tulane Avenue, SL-48, New Orleans, Louisiana 70112-2699. E-mail: lejemtel@tulane.edu.

REFERENCES

1. Barnes PJ. Chronic obstructive pulmonary disease. *N Engl J Med* 2000;343:269-80.
2. Jessup M, Brozena S. Medical progress: heart failure. *N Engl J Med* 2003;348:2007-18.
3. Egred M, Shaw S, Mohammad P, Waitt P, Rodriguez E. Under-use of beta-blockers in patients with ischaemic heart disease and concomitant chronic obstructive pulmonary disease. *Q J Med* 2005;98:493-7.
4. Rutten FH, Cramer MJ, Grobbee DE, et al. Unrecognized heart failure in elderly patients with stable chronic obstructive pulmonary disease. *Eur Heart J* 2005;26:887-94.
5. Havranek EP, Masoudi FA, Westfall KA, Wolfe P, Ordin DL, Krumholz HM. Spectrum of heart failure in older patients: results from the National Heart Failure Project. *Am Heart J* 2002;143:412-7.
6. O'Connor CM, Stough WG, Gallup DS, Hasselblad V, Gheorghade M. Demographics, clinical characteristics, and outcomes of patients hospitalized for decompensated heart failure: observations from the IMPACT-HF registry. *J Card Fail* 2005;11:200-5.
7. Braunstein JB, Anderson GF, Gerstenblith G, et al. Noncardiac comorbidity increases preventable hospitalizations and mortality among Medicare beneficiaries with chronic heart failure. *J Am Coll Cardiol* 2003;42:1226-33.
8. Gustafsson F, Torp-Pedersen C, Burchardt H, et al., DIAMOND Study Group. Female sex is associated with a better long-term survival in patients hospitalized with congestive heart failure. *Eur Heart J* 2004;25:129-35.
9. Dahlstrom U. Frequent noncardiac comorbidities in patients with chronic heart failure. *Eur J Heart Fail* 2005;7:309-16.
10. Ni H, Nauman D, Hershberger RE. Managed care and outcomes of hospitalization among elderly patients with congestive heart failure. *Arch Int Med* 1998;158:1231-6.
11. Render ML, Weinstein AS, Blaustein AS. Left ventricular dysfunction in deteriorating patients with chronic obstructive pulmonary disease. *Chest* 1995;107:162-8.
12. Curkendall SM, DeLuise C, Jones JK, et al. Cardiovascular disease in patients with chronic obstructive pulmonary disease, Saskatchewan Canada cardiovascular disease in COPD patients. *Ann Epidemiol* 2006;16:63-70.
13. Holguin F, Folch E, Redd SC, Mannino DM. Comorbidity and mortality in COPD-related hospitalizations in the United States, 1979 to 2001. *Chest* 2005;128:2005-11.
14. Sidney S, Sorel M, Quesenberry CP Jr., DeLuise C, Lanes S, Eisner MD. COPD and incident cardiovascular disease hospitalizations and mortality: Kaiser Permanente Medical Care Program. *Chest* 2005;128:2068-75.
15. Hole DJ, Watt GC, Davey-Smith G, Hart CL, Gillis CR, Hawthorne VM. Impaired lung function and mortality risk in men and women: findings from the Renfrew and Paisley prospective population study. *BMJ* 1996;313:711-5.
16. Pauwels RA, Buist AS, Calverley PM, Jenkins CR, Hurd SS, GOLD Scientific Committee. Global strategy for the diagnosis, management, and prevention of chronic obstructive pulmonary disease. NHLBI/WHO Global Initiative for Chronic Obstructive Lung Disease (GOLD) workshop summary. *Am J Respir Crit Care Med* 2001;163:1256-76.
17. Sin DD, Hogg J. Are Patients with chronic obstructive pulmonary disease at increased risk of cardiovascular morbidity and mortality? *CVR&R* 2004;25:168-70.
18. Sin DD, Man SF. Why are patients with chronic obstructive pulmonary disease at increased risk of cardiovascular diseases? The potential role of systemic inflammation in chronic obstructive pulmonary disease. *Circulation* 2003;107:1514-19.
19. Steele P, Ellis JH, Van Dyke D, Sutton F, Creagh E, Davies H. Left ventricular ejection fraction in severe chronic obstructive airways disease. *Am J Med* 1975;59:21-8.
20. Maisel A, Hollander JE, Guss D, et al. Primary results of Rapid Emergency Department Heart Failure Outpatient Trial (RED-HOT). A multicenter study of B-type natriuretic peptide levels, emergency department decision making, and outcomes in patients presenting with shortness of breath. *J Am Coll Cardiol* 2004;44:1328-33.
21. Steg PG, Joubin L, McCord J, et al. B-type natriuretic peptide and echocardiographic determination of ejection fraction in the diagnosis of congestive heart failure in patients with acute dyspnea. *Chest* 2005;128:21-9.
22. Mueller C, Laule-Kilian K, Frana B, et al. Use of B-type natriuretic peptide in the management of acute dyspnea in patients with pulmonary disease. *Am Heart J* 2006;151:471-7.
23. Tang WH, Girod JP, Lee MJ, et al. Plasma B-type natriuretic peptide levels in ambulatory patients with established chronic symptomatic systolic heart failure. *Circulation* 2003;108:2964-66.
24. Petrie MC, Hogg K, Caruana L, McMurray JJ. Poor concordance of commonly used echocardiographic measures of left ventricular diastolic function in patients with suspected heart failure but preserved systolic function: is there a reliable echocardiographic measure of diastolic dysfunction? *Heart* 2004;90:511-7.
25. Oh JK, Hatle L, Tajik J, Little W. Diastolic heart failure can be diagnosed by comprehensive two-dimensional and Doppler echocardiography. *J Am Coll Cardiol* 2006;47:500-6.
26. American Thoracic Society, European Respiratory Society. Skeletal muscle dysfunction in chronic obstructive pulmonary disease. *Am J Respir Care Med* 1999;159:S1-40.
27. Gosker HR, Wouters EF, van der Vusse GJ, Schols AM. Skeletal muscle dysfunction in chronic obstructive pulmonary disease and chronic heart failure: underlying mechanisms and therapy perspectives. *Am J Clin Nutr* 2000;71:1033-47.
28. Gosker HR, Lencer NH, Franssen FM, van der Vusse GJ, Wouters EF, Schols AM. Striking similarities in systemic factors contributing to decreased exercise capacity in patients with severe chronic heart failure or COPD. *Chest* 2003;123:1416-24.
29. Whittom F, Jobin J, Simard PM, et al. Histochemical and morphological characteristics of the vastus lateralis muscle in patients with chronic obstructive pulmonary disease. *Med Sci Sports Exerc* 1998;30:1467-74.
30. Jondeau G, Katz SD, Zohman L, et al. Active skeletal muscle mass and cardiopulmonary reserve. Failure to attain peak aerobic capacity during maximal bicycle exercise in patients with severe congestive heart failure. *Circulation* 1992;86:1351-6.
31. Killian KJ, Leblanc P, Martin DH, Summers E, Jones NL, Campbell EJ. Exercise capacity and ventilatory, circulatory, and symptom limitation in patients with chronic airflow limitation. *Am Rev Respir Dis* 1992;146:935-40.
32. Harrington D, Anker SD, Chua TP, et al. Skeletal muscle function and its relation to exercise tolerance in chronic heart failure. *J Am Coll Cardiol* 1997;30:1758-64.
33. Cicoira M, Zanolla L, Franceschini L, et al. Skeletal muscle mass independently predicts peak oxygen consumption and ventilatory response during exercise in noncachectic patients with chronic heart failure. *J Am Coll Cardiol* 2001;37:2080-5.
34. Yoshikawa M, Yoneda T, Takenaka H, et al. Distribution of muscle mass and maximal exercise performance in patients with COPD. *Chest* 2001;119:93-8.
35. Grove A, Lipworth BJ, Reid P, et al. Effects of regular salmeterol on lung function and exercise capacity in patients with chronic obstructive airways disease. *Thorax* 1996;51:689-93.
36. Ennezat PV, Ennezat CA, Vijayaraman P, et al. Dissociation between improvement in left ventricular performance and functional class in patients with chronic heart failure. *J Cardiovasc Pharmacol* 2005;46:577-85.
37. Jackman RW, Kandarian SC. The molecular basis of skeletal muscle atrophy. *Am J Physiol Cell Physiol* 2004;287:C834-43.

38. Sala E, Roca J, Marrades RM, et al. Effects of endurance training on skeletal muscle bioenergetics in chronic obstructive pulmonary disease. *Am J Respir Crit Care Med* 1999;159:1726-34.
39. Sullivan MJ, Higginbotham MB, Cobb FR. Exercise training in patients with severe left ventricular dysfunction. Hemodynamic and metabolic effects. *Circulation* 1988;78:506-15.
40. Mallat Z, Philip I, Lebreton MD, et al. Elevated levels of 8-iso-prostaglandin F₂alpha in pericardial fluid of patients with heart failure: a potential role for in vivo oxidant stress in ventricular dilatation and progression to heart failure. *Circulation* 1998;97:1536-9.
41. Gan WQ, Man SF, Senthilselvan A, Sin DD. Association between chronic obstructive pulmonary disease and systemic inflammation: a systematic review and a meta-analysis. *Thorax* 2004;59:574-80.
42. Vernooy JH, Kucukaycan M, Jacobs JA, et al. Local and systemic inflammation in patients with chronic obstructive pulmonary disease: soluble tumor necrosis factor receptors are increased in sputum. *Am J Respir Crit Care Med* 2002;166:1218-24.
43. Testa M, Yeh M, Lee P, et al. Circulation levels of cytokines and their endogenous modulators in patients with mild to severe congestive heart failure due to coronary artery disease and hypertension. *J Am Coll Cardiol* 1996;28:964-71.
44. Le Jemtel TH, Farr M, Moskowitz R. Alterations in skeletal muscle. In: Mann DL, editor. *Heart Failure*. Philadelphia, PA: Saunders, 2004:291-302.
45. Hambrecht R, Schulze PC, Gielen S, et al. Reduction of insulin-like growth factor-I expression in the skeletal muscle of noncachectic patients with chronic heart failure. *J Am Coll Cardiol* 2002;39:1175-81.
46. Niebauer J, Pflaum CD, Clark AL, et al. Deficient insulin-like growth factor I in chronic heart failure predicts altered body composition, anabolic deficiency, cytokine and neurohormonal activation. *J Am Coll Cardiol* 1998;32:393-7.
47. Guttridge DC. Signaling pathways weigh in on decisions to make or break skeletal muscle. *Curr Opin Clin Nutr Metab Care* 2004;7:443-50.
48. Glass DJ. Signaling pathways that mediate skeletal muscle hypertrophy and atrophy. *Nat Cell Biol* 2003;5:87-90.
49. Latres E, Amini AR, Amini AA, et al. Insulin-like growth factor-1 (IGF-1) inversely regulates atrophy-induced genes via the phosphatidylinositol 3-kinase/Akt/mammalian target of rapamycin (PI3K/Akt/mTOR) pathway. *J Biol Chem* 2005;280:2737-44.
50. Sandri M, Sandri C, Gilbert A, et al. FOXO transcription factors induce the atrophy-related ubiquitin ligase atrogin-1 and cause skeletal muscle atrophy. *Cell* 2004;117:399-412.
51. Satchek JM, Ohtsuka A, McLary SC, Goldberg AL. IGF-I stimulates muscle growth by suppressing protein breakdown and expression of atrophy-related ubiquitin ligases, atrogin-1 and MuRF1. *Am J Physiol Endocrinol Metab* 2004;287:E591-601.
52. Jagoe RT, Goldberg AL. What do we really know about the ubiquitin-proteasome pathway in muscle atrophy? *Curr Opin Clin Nutr Metab Care* 2001;4:183-90.
53. Du J, Wang X, Miereles C, et al. Activation of caspase-3 is an initial step triggering accelerated muscle proteolysis in catabolic conditions. *J Clin Invest* 2004;113:115-23.
54. Mitch WE, Goldberg AL. Mechanisms of muscle wasting. The role of the ubiquitin-proteasome pathway. *N Engl J Med* 1996;335:1897-905.
55. Libera LD, Vescovo G. Muscle wastage in chronic heart failure, between apoptosis, catabolism and altered anabolism: a chimaeric view of inflammation? *Curr Opin Clin Nutr Metab Care* 2004;7:435-41.
56. Persinger R, Janssen-Heininger Y, Wing SS, Matthews DE, LeWinter MM, Toth MJ. Effect of heart failure on the regulation of skeletal muscle protein synthesis, breakdown, and apoptosis. *Am J Physiol Endocrinol Metab* 2003;284:E1001-8.
57. Florini JR, Ewton DZ, Cooligan SH. Growth hormone and the insulin-like growth factor system in myogenesis. *Endocr Rev* 1996;17:481-517.
58. Kojima M, Kangawa K. Ghrelin: structure and function. *Physiol Rev* 2005;85:495-522.
59. Nagaya N, Moriya J, Yasumura Y, et al. Effects of ghrelin administration on left ventricular function, exercise capacity, and muscle wasting in patients with chronic heart failure. *Circulation* 2004;110:3674-9.
60. Nagaya N, Itoh T, Murakami S, et al. Treatment of cachexia with ghrelin in patients with COPD. *Chest* 2005;128:1187-93.
61. The SOLVD Investigators. Effect of enalapril on survival in patients with reduced left ventricular ejection fractions and congestive heart failure. *N Engl J Med* 1991;325:293-302.
62. Jones A, Woods DR. Skeletal muscle RAS and exercise performance. *Int J Biochem Cell Biol* 2003;35:855-66.
63. Anker SD, Negassa A, Coats AJ, et al. Prognostic importance of weight loss in chronic heart failure and the effect of treatment with angiotensin-converting-enzyme inhibitors: an observational study. *Lancet* 2003;361:1077-83.
64. Coirault C, Hagege A, Chemla D, Fratacci MD, Guerot C, Lecarpentier Y. Angiotensin-converting enzyme inhibitor therapy improves respiratory muscle strength in patients with heart failure. *Chest* 2001;119:1755-60.
65. Maggio M, Ceda GP, Lauretani F, et al. Relation of angiotensin-converting enzyme inhibitor treatment to insulin-like growth factor-1 serum levels in subjects >65 years of age (the InCHIANTI study). *Am J Cardiol* 2006;97:1525-9.
66. Mancini GB. The "double dip" hypothesis: simultaneous prevention of cardiovascular and pulmonary morbidity and mortality using angiotensin II type 1 receptor blockers. *Can J Cardiol* 2005;21:519-23.
67. Kuba K, Imai Y, Penninger JM. Angiotensin-converting enzyme 2 in lung diseases. *Curr Opin Pharmacol* 2006;6:271-6.
68. Morrell NW, Higham MA, Phillips PG, Shakur BH, Robinson PJ, Beddoes RJ. Pilot study of losartan for pulmonary hypertension in chronic obstructive pulmonary disease. *Respir Res* 2005;6:88.
69. Andreas S, Herrmann-Lingen C, Raupach T, et al. Angiotensin II blockers in obstructive pulmonary disease: a randomised controlled trial. *Eur Respir J* 2006;27:972-9.
70. Packard KA, Wurdeman RL, Arouni AJ. ACE inhibitor-induced bronchial reactivity in patients with respiratory dysfunction. *Ann Pharmacother* 2002;36:1058-67.
71. Lee JH, Lee DS, Kim EK, et al. Simvastatin inhibits cigarette smoking-induced emphysema and pulmonary hypertension in rat lungs. *Am J Respir Crit Care Med* 2005;172:987-93.
72. Nishimura T, Vaszar LT, Faul JL, et al. Simvastatin rescues rats from fatal pulmonary hypertension by inducing apoptosis of neointimal smooth muscle cells. *Circulation* 2003;108:1640-5.
73. Node K, Fujita M, Kitakaze M, Hori M, Liao JK. Short-term statin therapy improves cardiac function and symptoms in patients with idiopathic dilated cardiomyopathy. *Circulation* 2003;108:839-43.
74. Mann DL, McMurray JJ, Packer M, et al. Targeted anticytokine therapy in patients with chronic heart failure: results of the Randomized Etanercept Worldwide Evaluation (RENEWAL). *Circulation* 2004;109:1594-602.
75. Chung ES, Packer M, Lo KH, Fasanmade AA, Willerson JT, Anti-TNF Therapy Against Congestive Heart Failure Investigators. Randomized, double-blind, placebo-controlled, pilot trial of infliximab, a chimeric monoclonal antibody to tumor necrosis factor-alpha, in patients with moderate-to-severe heart failure: results of the Anti-TNF Therapy Against Congestive Heart Failure (ATTACH) trial. *Circulation* 2003;107:3133-40.
76. Mancini G, Etminan M, Zhang B, et al. Reduction of morbidity and mortality by statins, angiotensin-converting enzyme inhibitors and angiotensin receptor blockers in patients with chronic obstructive pulmonary disease. *J Am Coll Cardiol* 2006;47:2554-60.
77. Bellotti P, Badano LP, Acquarone N, et al., OSCUR Investigators. Specialty-related differences in the epidemiology, clinical profile, management and outcome of patients hospitalized for heart failure: the OSCUR study. *Eur Heart J* 2001;22:596-604.
78. Popio KA, Jackson DH Jr., Utell MJ, Swinburne AJ, Hyde RW. Inhalation challenge with carbachol and isoproterenol to predict bronchospastic response to propranolol in COPD. *Chest* 1983;83:175-9.
79. George RB, Manocha K, Burford JG, Conrad SA, Kinasewitz GT. Effects of labetalol in hypertensive patients with chronic obstructive pulmonary disease. *Chest* 1983;83:457-60.
80. Salpeter S, Ormiston T, Salpeter E. Cardioselective beta-blockers for chronic obstructive pulmonary disease. *Cochrane Database Syst Rev* 2005;4:CD003566.
81. Fenster PE, Hasan FM, Abraham T, Woolfenden J. Effects of metoprolol on cardiac and pulmonary function in chronic obstructive pulmonary disease. *Clin Cardiol* 1983;6:125-9.

82. van der Woude HJ, Zaagsma J, Postma DS, Winter TH, van Hulst M, Aalbers R. Detrimental effects of beta-blockers in COPD: a concern for nonselective beta-blockers. *Chest* 2005;127:818-24.
83. Lammers JW, Folgering HT, van Herwaarden CL. Ventilatory effects of long-term treatment with pindolol and metoprolol in hypertensive patients with chronic obstructive lung disease. *Br J Clin Pharmacol* 1985;20:205-10.
84. Tivenius L. Effects of multiple doses of metoprolol and propranolol on ventilatory function in patients with chronic obstructive lung disease. *Scand J Respir Dis* 1976;57:190-6.
85. Wunderlich J, Macha HN, Wudicke H, Huckauf H. Beta-adrenoceptor blockers and terbutaline in patients with chronic obstructive lung disease. Effects and interaction after oral administration. *Chest* 1980;78:714-20.
86. Dorow P, Bethge H, Tonnesmann U. Effects of single oral doses of bisoprolol and atenolol on airway function in nonasthmatic chronic obstructive lung disease and angina pectoris. *Eur J Clin Pharmacol* 1986;31:143-7.
87. Camsari A, Arikan S, Avan C, et al. Metoprolol, a beta-1 selective blocker, can be used safely in coronary artery disease patients with chronic obstructive pulmonary disease. *Heart Vessels* 2003;18:188-92.
88. The Heart Failure Society of America. Executive summary: HFSA 2006 comprehensive heart failure practice guideline. *J Card Fail* 2006;12:10-38.
89. Kotlyar E, Keogh AM, Macdonald PS, Arnold RH, McCaffrey DJ, Glanville AR. Tolerability of carvedilol in patients with heart failure and concomitant chronic obstructive pulmonary disease or asthma. *J Heart Lung Transplant* 2002;21:1290-5.
90. Krum H, Ninio D, MacDonald P. Baseline predictors of tolerability to carvedilol in patients with chronic heart failure. *Heart* 2000;84:615-9.
91. Macdonald P, Keogh A, Aboyoum C, Lund M, Amor R, McCaffrey D. Tolerability and efficacy of carvedilol in patients with New York Heart Association class IV heart failure. *J Am Coll Cardiol* 1999;33:924-31.
92. Chen J, Radford MJ, Wang Y, Marciniak TA, Krumholz HM. Effectiveness of beta-blocker therapy after acute myocardial infarction in elderly patients with chronic obstructive pulmonary disease or asthma. *J Am Coll Cardiol* 2001;37:1950-6.
93. Gottlieb SS, McCarter RJ, Vogel RA. Effect of beta-blockade on mortality among high-risk and low-risk patients after myocardial infarction. *N Engl J Med* 1998;339:489-97.
94. Barnett MJ, Milavetz G, Kaboli PJ. Beta-blocker therapy in veterans with asthma or chronic obstructive pulmonary disease. *Pharmacotherapy* 2005;25:1550-9.
95. Shelton RJ, Rigby AS, Cleland JG, Clark AL. Effect of a community heart failure clinic on uptake of beta blockers by patients with obstructive airways disease and heart failure. *Heart* 2006;92:331-6.
96. Hoppers JJ, Postma DS, Rijcken B, Weiss ST, Schouten JP. Histamine airway hyper-responsiveness and mortality from chronic obstructive pulmonary disease: a cohort study. *Lancet* 2000;356:1313-7.
97. Callaerts-Vegh Z, Evans KL, Dudekula N, et al. Effects of acute and chronic administration of beta-adrenoceptor ligands on airway function in a murine model of asthma. *Proc Natl Acad Sci U S A* 2004;101:4948-53.
98. McGraw DW, Fukuda N, James PF, et al. Targeted transgenic expression of beta(2)-adrenergic receptors to type II cells increases alveolar fluid clearance. *Am J Physiol Lung Cell Mol Physiol* 2001;281:L895-903.
99. Wellstein A, Palm D, Belz G, Butzer R, Polsak R, Pett B. Reduction of exercise tachycardia in man after propranolol, atenolol and bisoprolol in comparison to beta-adrenoceptor occupancy. *Eur Heart J* 1987;8 Suppl M:3-8.
100. Baker JG. The selectivity of beta-adrenoceptor antagonists at the human beta1, beta2 and beta3 adrenoceptors. *Br J Pharmacol* 2005;144:317-22.
101. Carstairs JR, Nimmo AJ, Barnes PJ. Autoradiographic visualization of beta-adrenoceptor subtypes in human lung. *Am Rev Respir Dis* 1985;132:541-7.
102. Baker JG, Hall IP, Hill SJ. Influence of agonist efficacy and receptor phosphorylation on antagonist affinity measurements: differences between second messenger and reporter gene responses. *Mol Pharmacol* 2003;64:679-88.
103. Salpeter SR, Ormiston TM, Salpeter EE. Cardiovascular effects of beta-agonists in patients with asthma and COPD: a meta-analysis. *Chest* 2004;125:2309-21.
104. Martin RM, Dunn NR, Freemantle SN, Mann RD. Risk of nonfatal cardiac failure and ischaemic heart disease with long acting beta 2 agonists. *Thorax* 1998;53:558-62.
105. Au DH, Udris EM, Fan VS, Curtis JR, McDonnell MB, Fihn SD. Risk of mortality and heart failure exacerbations associated with inhaled beta-adrenoceptor agonists among patients with known left ventricular systolic dysfunction. *Chest* 2003;123:1964-9.
106. Cazzola M, Imperatore F, Salzillo A, et al. Cardiac effects of formoterol and salmeterol in patients suffering from COPD with preexisting cardiac arrhythmias and hypoxemia. *Chest* 1998;114:411-5.