

# Assessment of collection systems for HVDC connected offshore wind farms



Padmavathi Lakshmanan<sup>\*</sup>, Jun Liang, Nicholas Jenkins

*Institute of Energy, School of Engineering, Cardiff University, Cardiff, UK*

## ARTICLE INFO

### Article history:

Received 9 February 2015

Received in revised form 1 July 2015

Accepted 24 July 2015

Available online 13 August 2015

### Keywords:

Offshore wind farms

DC collection

Economic assessment

Loss analysis

DC–DC converters

## ABSTRACT

A technical and economic comparison is made between DC and AC collection systems of offshore wind farms. DC collection systems have the advantages of reduced weight and size of the DC cables and DC cables are free from reactive power compensation. The heavy 50/60 Hz transformers in the offshore transmission platform of AC collection systems can be replaced with smaller size medium frequency transformers in DC collection systems. However, the need for a high power DC–DC converter with high voltage transformation ratios and DC protection methods will remain a challenge for the DC collection systems. Also, DC collection systems do not necessarily reduce the power conversion stages compared to the AC collection systems even if HVDC (High Voltage DC) transmission is used to transfer the offshore wind power from the collection systems to the onshore grids. A cost assessment study verifies that the cost reductions achieved by the reduced size of the DC cables and offshore platform are outweighed by the cost of DC protective devices and DC–DC converters. This is because the length of the DC collection cables is relatively short compared to the long distance HVDC cables. The technical comparison supported by the simulation results shows that the total losses in the DC collection systems are higher than in AC collection systems. The effect of collection bus voltages on the losses is analysed for the DC collection systems.

© 2015 The Authors. Published by Elsevier B.V. This is an open access article under the CC BY license (<http://creativecommons.org/licenses/by/4.0/>).

## 1. Introduction

The technical and economic performance of a wind farm depends on the configuration of the collection and transmission systems. AC collection system options for offshore wind farms were discussed in [1]. The 50/60 Hz transformers used on the offshore transmission platform of AC collection systems are heavy and require a large support structure leading to a high transport and installation cost. The reactive power compensating devices and the power quality filters also consume space on the offshore platform [2].

With the aim of reducing the footprint and size of the offshore platforms, the idea of DC collection systems with DC–DC conversion is being studied. The control structure and different possible configurations of the DC collection systems were discussed in [3]. Several topologies of isolated DC–DC converters including the full bridge DC–DC converter, single active bridge converter, and resonant converters were studied and their energy efficiencies were compared in [4]. In [5,6], DC collection systems using resonant

DC–DC converters were analysed. Research on finding a suitable DC–DC converter topology for DC collection systems is still ongoing and several novel topologies of high power DC–DC converters have been proposed in [7,8].

Comparative studies of different collection configurations have been performed to identify the technical and economic benefits of alternative collection topologies. The DC series connection of wind turbines was compared with AC radial transmission in [9]. The cost and losses of the offshore wind farms based on centralized power electronic converters [10] were compared for AC and DC configurations. In the AC and DC collection comparative study [11], DC series and DC series-parallel collection systems were identified as cost effective.

DC collection systems have a number of advantages. The medium frequency transformers used in isolated DC–DC converters reduce the size of the converters. The elimination 50/60 Hz transformer with DC–DC converters can save space on the offshore platform and yield associated savings in cost. The weight and size of DC collection cables are smaller than those of AC cables. DC collection cables will not require reactive power compensation. DC transmission and collection systems will essentially decouple a wind farm from the onshore grid and enhance the fault withstand capability of wind turbines.

<sup>\*</sup> Corresponding author. Tel.: +44 7596552207.

E-mail address: [LakshmananP2@cardiff.ac.uk](mailto:LakshmananP2@cardiff.ac.uk) (P. Lakshmanan).

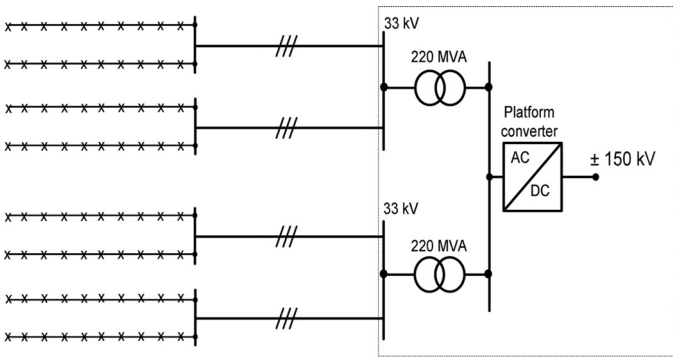

Fig. 1. AC collection systems.

However, the challenges of the DC collection systems also need to be considered. The isolated DC–DC converters of offshore wind farms require medium frequency transformers with high voltage transformation ratios. Complexities in the construction of such high power medium frequency transformers increase the cost of DC–DC converters. DC collection systems do not necessarily reduce the power conversion stages compared to the AC collection systems. A reduced power conversion stage is possible only with turbines of higher ratings and high output voltage. Developing cost effective protection methods is also a challenge for DC collection systems.

2. Collection topologies considered

The wind farm considered in this study is rated at 400 MW. This wind farm has 80 turbines each rated at 5 MW. Each wind turbine uses a Permanent Magnet Synchronous Generator (PMSG) rated at 690 V. The voltage of the HVDC link is ±150 kV.

2.1. AC collection systems

The AC collection topology considered for comparison is shown in Fig. 1. AC–DC and DC–AC converters in the wind turbines use two-level VSC converters. The switching frequency of these converters is 1260 Hz. A wind turbine transformer steps up the voltage from 690 V to 33 kV. The AC collection systems use a 33 kV collection bus voltage. A cable length of 5 km between the wind turbine strings and the medium voltage collection bus is assumed. The offshore transmission platform has two transformers each rated at 220 MVA (33 kV/155 kV) and a platform converter. This two-level VSC platform converter is rated at 400 MW.

2.2. DC collection systems

A DC collection topology-1, (referred as DC1) similar to the AC collection and another DC collection topology-2 (referred as DC2) using centralized DC–DC converters are considered for DC collection systems.

The structure of DC1 collection systems is shown in Fig. 2. Each turbine is connected to a medium voltage DC–DC converter (referred as turbine DC converter). The turbine DC converter is rated at 5 MW. A cable length of 5 km between the wind turbine strings and the collection bus is assumed and the collection bus voltage is rated at 30 kV. Another DC–DC converter on the offshore platform (referred as platform DC converter) is used. The platform DC converter is rated at 400 MW.

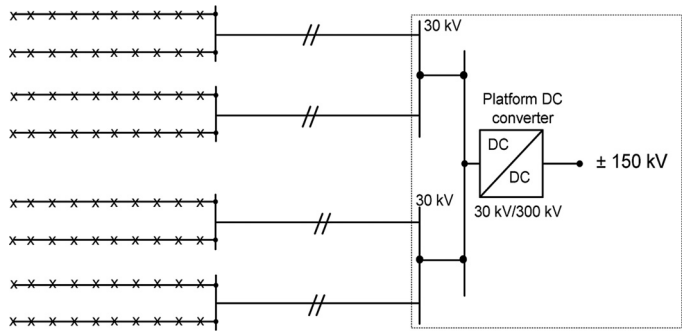

Fig. 2. DC1 collection systems.

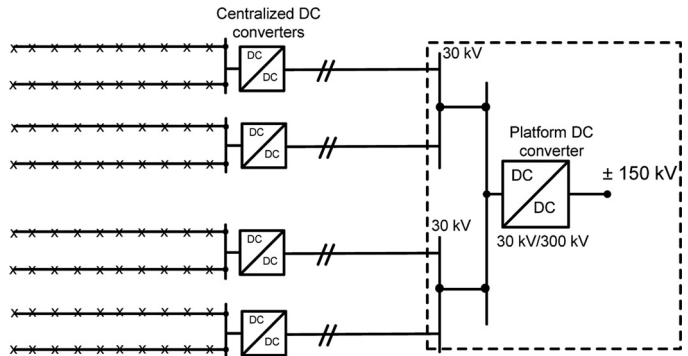
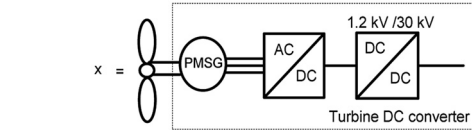
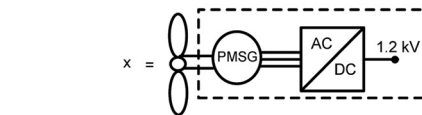

Fig. 3. DC2 collection systems.



The structure of the DC2 collection systems is shown in Fig. 3. In this configuration, a group of wind turbines with DC output in strings is connected to centralized DC–DC converters (referred as centralized DC converters). The centralized DC converters are placed on a converter platform closer to the turbines. A cable length of 5 km between the centralized converter platform and the collection bus is assumed. The collection bus voltage is rated at 30 kV. The advantage of this configuration is that the DC–DC converters located at each wind turbines are removed. This helps to reduce the number of power electronic converters in the wind turbines. Another platform DC converter is used on the transmission platform. This DC2 collection configuration considered is different from the centralized converter concept described in [20]. The centralized converter configuration in [20] eliminates a single stage of power conversion by considering a medium output voltage turbines and a high voltage transformation ratio DC–DC converters.

A hard switched full bridge DC–DC converter employing duty cycle control is used for the turbine DC converter, centralized DC converters and platform DC converter. The circuit of a full-bridge DC–DC converter is shown in Fig. 4a and the duty cycle control structure in Fig. 4b. In DC1 collection systems, the turbine DC converter maintains the internal DC link voltage of each turbine constant. In DC2 collection systems, the centralized DC converters maintain the internal DC link voltage of the turbines constant.

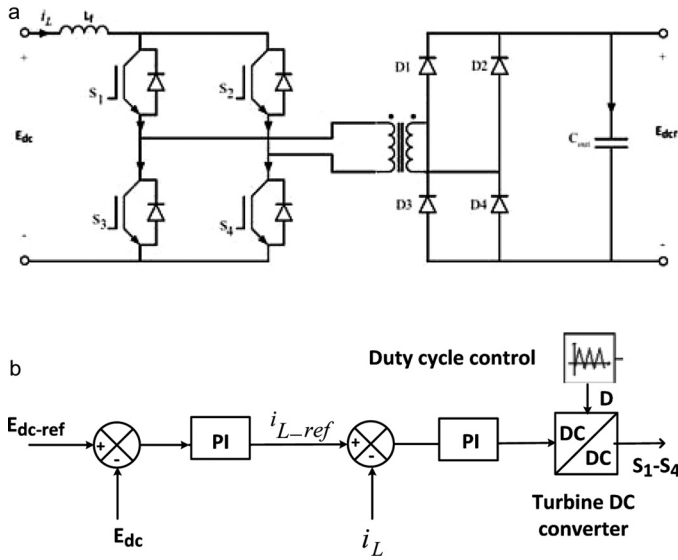

Fig. 4. (a) Full-bridge DC–DC converter. (b) Duty cycle control of full-bridge DC–DC converter.

The platform DC converter maintains the collection bus voltage constant in both the DC collection systems.

The switching frequency of the medium frequency transformers used in the DC converters is 1000 Hz. The 1000 Hz frequency was suggested in [12] from an optimization study of frequency with respect to the size and losses of the medium frequency transformers.

The DC collection topologies assume the possibility to achieve a high voltage transformation ratio for DC–DC converters. Novel topologies of high power DC–DC converters with high voltage transformation ratio have been proposed in [8,9] for offshore wind farm applications.

The BARD offshore 1 wind farm [27] rated at 400 MW uses 80 turbines of 5 MW each and uses HVDC transmission to the onshore grid. Roughly based on this wind farm size, the losses and cost aspects of offshore wind farms with AC and DC collection configurations are compared. The scope of this paper focuses on internal collection systems and an effort has been made to identify the components contributing to the losses and cost in the DC collection systems.

### 3. Loss estimation

#### 3.1. Wind farm energy calculation

The power generated at each wind speed is calculated by the wind turbine characteristic as

$$P_{gen\_wt}(v_w) = \frac{1}{2} \rho A C_p v_w^3 \quad (1)$$

where  $P_{gen\_wt}(v_w)$  is the power generated at each wind speed (W);  $\rho$  the air density ( $\text{kg}/\text{m}^3$ );  $A$  the area swept by the turbine blades ( $\text{m}^2$ );  $v_w$  the wind speed (m/s);  $C_p$  the power coefficient.

The amount of annual energy generated by the wind turbines is calculated by multiplying the power generated as function of wind speed, probability of occurrence of the wind speed and the number of hours in a year as in (2). The Weibull probability distribution function in (3) describes the probability of occurrence of the wind speed wind speed. The mathematical description of this is as follows:

$$E_{gen\_wt} = N_{wt} \int_{V_{min}}^{V_{max}} (P_{gen\_wt}(v_w)) f(v_w) 8760 dv_w \quad (2)$$

$$f(v_w) = \frac{k}{c} \left( \frac{v_w}{c} \right)^{k-1} e^{-\left( \frac{v_w}{c} \right)^k} \quad (3)$$

where  $E_{gen\_wt}$  is the annual energy generated by the wind farm;  $V_{min}$  the cut in wind speed (m/s);  $V_{max}$  the cut out wind speed (m/s);  $f(v_w)$  the Weibull probability distribution function of occurrence of each wind speed;  $N_{wt}$  the number of wind turbines;  $k$  and  $c$  the shape and scale parameters of Weibull distribution function ( $k=2$  and  $c=9.5$ ).

The wind turbine is rated at 5 MW. The cut in wind speed is 5 m/s and the cut out wind speed is 20 m/s. The rated wind speed is 13 m/s.

The steady state operation of the wind turbines with the proposed collection configurations was simulated using PSCAD/EMTDC. The simulation was carried out from the cut in wind speed to the cut out wind speed; beyond the rated speed, pitch control was used to keep the output power of the turbines constant.

#### 3.2. Power electronics losses

The losses in the power electronic converters were estimated using the operating conditions obtained from the simulations and from the manufacturing datasheet of the power electronic components. The loss estimation is based on the ABB IGBT device ABB5SNA2400E170100. This device has a blocking voltage of 1700 V and a rated current of 2400 A. The power electronic losses are the sum of the switching and conduction losses in the IGBTs and the freewheeling diodes [13] which are explained as follows:

$$P_{IGBT} = N_{sw}(V_{CE0}I_{c,ave} + R_C I_{c,rms}^2 + (E_{onT} + E_{offT})f_{sw}) \quad (4)$$

$$P_{FWD} = N_{sw}(V_{D0}I_{d,ave} + R_D I_{d,rms}^2 + E_{onD}f_{sw}) \quad (5)$$

where  $V_{CE0}$  is the IGBT on-state voltage (V);  $I_{c,ave}$  the average value of the IGBT current (A);  $R_C$  the IGBT on-state resistance ( $\Omega$ );  $I_{c,rms}$  the RMS value of the IGBT current (A);  $E_{onT}$  the turn-on energy losses of IGBT (W);  $E_{offT}$  the turn-off energy losses of IGBT (W);  $f_{sw}$  the switching frequency (Hz);  $V_{D0}$  the diode on-state voltage (V);  $I_{d,ave}$  the average value of the diode current (A);  $R_D$  the diode on-state resistance ( $\Omega$ );  $I_{d,rms}$  the RMS value of the diode current (A);  $E_{onD}$  the reverse recovery energy losses in diode (W);  $N_{sw}$  the number of power electronic switches;  $P_{IGBT}$  the conduction and switching losses in IGBT (W);  $P_{FWD}$  the conduction and switching losses in freewheeling diode (W).

$V_{CE0}$  and  $R_C$  were obtained by approximating the on-state characteristics in the datasheet curve.  $E_{onT}$ ,  $E_{offT}$  and  $E_{onD}$  were obtained from the collector current–switching loss characteristics curve of the datasheet. The current carried by the power electronic converters for each wind speed was obtained from the simulation. This current was used to estimate the losses in power electronics converters across the range of wind speeds considered.

For AC collection systems, the power electronics losses include the losses in the AC–DC converters, DC–AC converters in the wind turbines and the platform converter. For the DC1 collection systems, the power electronic losses include the losses in the wind turbine AC–DC converters, turbine DC converters and the platform DC converter. For the DC2 configuration, the power electronic losses include the losses in the wind turbine AC–DC converters, centralized DC converters and the platform DC converter.

In AC collection systems, the platform converter losses at full load were estimated by the above calculation method as 1.24%. This is reasonable as the expected VSC–HVDC converter losses for a 500 MW wind farm is 1–2% according to [14].

An efficiency of 99% for the medium frequency transformers [15] was assumed for all the DC collection configurations and added to the power electronic converter losses in the DC–DC converters. A similar value of efficiency was assumed for the wind turbine

**Table 1**  
Loss estimation in AC and DC collection systems.

Case	Collection type	Yearly energy losses (GW h)			Efficiency (%)	
		Power electronics (including transformers)	Collection cables	Total		
400 MW energy extracted: 1128.70 GW h	AC	81.00 (7.18%)	2.74 (0.24%)	83.74 (7.42%)	1044.90	92.58
	DC1	83.76 (7.42%)	2.60 (0.23%)	86.36 (7.65%)	1042.30	92.35
	DC2	82.50 (7.31%)	2.60 (0.23%)	85.10 (7.54%)	1043.60	92.46
200 MW energy extracted: 564.33 GW h	AC	40.24 (7.13%)	1.37 (0.24%)	41.61 (7.37%)	522.72	92.63
	DC1	42.47 (7.53%)	1.30 (0.23%)	43.77 (7.76%)	520.56	92.24
	DC2	41.34 (7.33%)	1.30 (0.23%)	42.64 (7.56%)	521.69	92.44

transformers and offshore platform transformers of the AC collection systems.

### 3.3. Collection cables losses

The collection cables were modelled by a single pi section with lumped parameters for the length of the collection cables considered. The operating current corresponding to the each wind speed obtained from the simulation results and the resistance calculated from cable data [16] was used to estimate the losses in the AC and DC cables. In the AC collection systems, the cable losses were estimated taking into account the reactive power requirements.

### 3.4. Annual energy losses

The losses in the collection system components were integrated over the Weibull probability distribution of the wind speed to estimate the annual energy losses.

$$E_{losses_{AC}} = \int_{V_{min}}^{V_{max}} (P_{PE_{AC}}(v_w) + P_{cable_{AC}}(v_w))f(v_w)8760 dv_w \quad (6)$$

$$E_{losses_{DCn}} = \int_{V_{min}}^{V_{max}} (P_{PE_{DCn}}(v_w) + P_{cable_{DCn}}(v_w))f(v_w)8760dv_w \quad (7)$$

where  $E_{losses_{AC}}$  is the annual energy losses in AC collection systems;  $E_{losses_{DCn}}$  the annual energy losses in DC collection systems;  $P_{cable_{AC}}$  the total cable losses in AC collection systems;  $P_{cable_{DCn}}$  the total cable losses in DC collection systems;  $P_{PE_{AC}}$  the total power electronic losses in AC collection systems;  $P_{PE_{DCn}}$  the total power electronic losses in DC collection systems,  $n = 1$  for DC1 and  $n = 2$  for DC2.

The results of loss estimation are shown in Table 1. The results show that the total collection systems losses in the DC1 configuration are 0.23% higher than the AC collection systems losses and the DC2 configuration losses are 0.12% higher than the AC collection systems losses for the 400 MW wind farm. The DC2 configuration uses centralized DC converters and hence the losses in this configuration are lower than in the DC1 configuration.

The loss estimation was also carried out for the case of a 200 MW wind farm. In this case, 10 turbines in a single string were considered for all the collection systems (Figs. 1–3). In the case of a 200 MW wind farm, the losses of the DC1 configuration are 0.39% higher than in the AC collection systems and the DC2 configuration losses are 0.19% higher than the AC collection systems. The efficiency of all the collection systems over the wind speed range is plotted in Fig. 5.

The increase in losses in DC collection systems was mainly contributed by the losses in the turbine DC and platform DC converters. In the DC collection systems, the transformers are part of the DC–DC converters. This makes the DC–DC converters carry higher currents than the converters of AC collection systems under similar operating conditions and increases the power electronic losses in the DC–DC converters. In the AC collection systems, reactive power

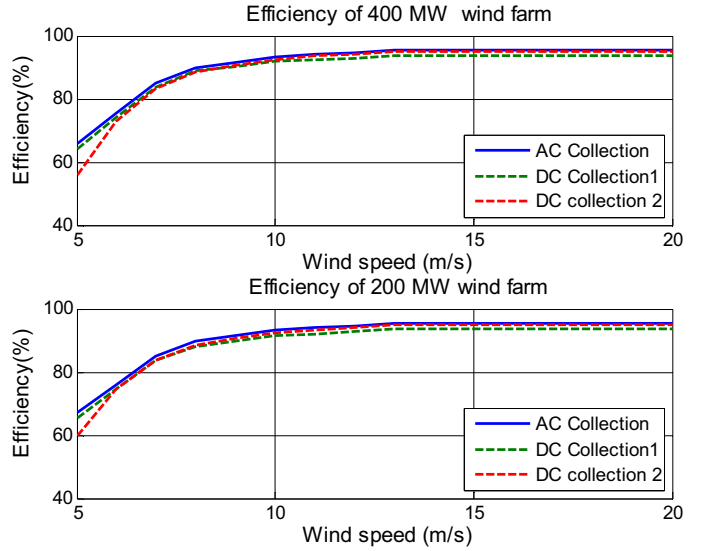

Fig. 5. Efficiency plot of AC and DC collection systems.

does not significantly increase the collection cable losses due to the relatively shorter AC collection cables. As long as the stages of power conversions remain the same, it is not possible to expect the losses to decrease in DC collection systems.

## 4. Cost assessment

An approximate cost assessment study was carried out considering the costs of investment and losses for the collection system components. This includes the collection cables, power electronic converters, switch gear and offshore platforms. The cost for individual components was calculated based on the cost models described below for both the AC and DC collection system components. These individual component costs were then multiplied by the number of components in the wind farm to obtain the total investment cost.

### 4.1. Cost of wind turbine power electronics converters

The cost of a single wind turbine AC–DC converter and DC–AC converter is considered as 60 €/kVA [10]. In DC collection systems, the turbine DC converters are priced at 165 €/kW [17].

### 4.2. Cost of transformers

The cost of the transformer in the AC collection systems was calculated by the cost model for the transformer in [18] as below:

$$C_{transformers} = 1000(-122.4 + 105P^{0.447}) \quad (8)$$

where  $P$  is the transformer rating in MVA and  $C_{transformers}$  the transformer cost in £.



**Table 2**  
Cost estimation 5 km collection cable length.

Case	cost (M£)						Total cost (M£)
	Collection type	Turbine power electronics	Collection cables	Platform	Protection	Cost of losses	
400 MW	AC	55.44	65.63	101.70	8.40	53.47	284.64
	DC1	76.00	32.98	90.68	72.97	55.14	327.77
	DC2	24.00	32.98	172.38	61.76	54.34	345.46
200 MW	AC	27.72	32.82	52.05	4.20	26.57	143.36
	DC1	38.00	16.49	45.94	36.49	27.95	164.87
	DC2	12.00	16.49	87.09	30.88	27.22	173.68

4.3. Cost of collection cables

The collection cable cost was calculated based on the current and voltage rating of the cables. The AC cable cost model [18] is as below:

$$C_{AC \text{ cables}} \text{ (per km)} = (A + Be^{(C_{ln}/10^5)}) + C_{inst-AC \text{ cables}} \quad (9)$$

For 30–36 kV cables:  $A = 0.042 \text{ M£/km}$ ;  $B = 0.06 \text{ M£/km}$ ;  $C = 234.34/A$ ;  $I_n$  = cable ampacity.

An installation cost of  $0.292 \text{ M£/km}$  is also used [10].

$$C_{inst-AC \text{ cables}} = 0.292 \text{ M£/km.}$$

The DC cable cost model [19] is as below:

$$C_{DC \text{ cables}} \text{ (per km)} = (A + BV_n I_n) + C_{inst-DC \text{ cables}} \quad (10)$$

For 30 kV cables:  $A = -0.0256e6$ ;  $B = 0.0068$ .

$$C_{inst-DC \text{ cables}} = (2/3) \times 0.292 \text{ M£/km.}$$

$V_n, I_n$  = rated voltage and current of the cables, respectively.

DC cable installation cost was obtained by multiplying the installation cost of AC cables by a factor of  $2/3$  so as to take into account the reduced cable weight and size of the DC cables compared to the AC cables. This is a sensitive factor and will influence the total cost comparison results.

4.4. Cost of offshore platform

The offshore platform cost is based on the amount of power processed [10]. The platform cost models are described below:

$$C_{offshore \text{ platform-AC}} = C_{plat-AC}(A + BP) \quad (11)$$

$$C_{offshore \text{ platform-DC}} = C_{plat-DC}(A + BP) \quad (12)$$

where  $A = 2.4 \text{ M£}$ ;  $B = 0.083 \text{ M£}$ ;  $C_{plat-AC} = 1$ ;  $C_{plat-DC} = 0.5$ ; and  $P$  is the rated power of the wind farm in MW.

The weight of a 3 MVA AC transformer was calculated as 7430 kg in [6] and a similar rated medium frequency transformer designed at 500 Hz had the core weight as 1924 kg [15]. This shows that the weight of a medium frequency transformer is approximately one quarter of that of the 50/60 Hz transformer. The weight reduction achieved by the use of medium frequency transformers will decrease the installation cost of the DC offshore platform and the size reduction will save space in the offshore platform. Taking into account these considerations in DC collection systems, a factor of 0.5 is multiplied to the DC collection systems platform cost. The total cost comparison results are sensitive to this assumed fixed value.

The cost of the platform converter in AC collection systems is considered as  $0.16 \text{ M£/MW}$  [17]. For DC collection systems, the platform DC converters are priced at  $0.22 \text{ M£/MW}$  [17]. The platform converter cost is added to the offshore platform cost.

The DC2 systems use an additional converter platform, the cost of which was assumed to be 50% of that of the transmission platform [10]. For DC2 systems, the platform cost includes the converter platform, centralized converters, transmission platform and platform DC converter.

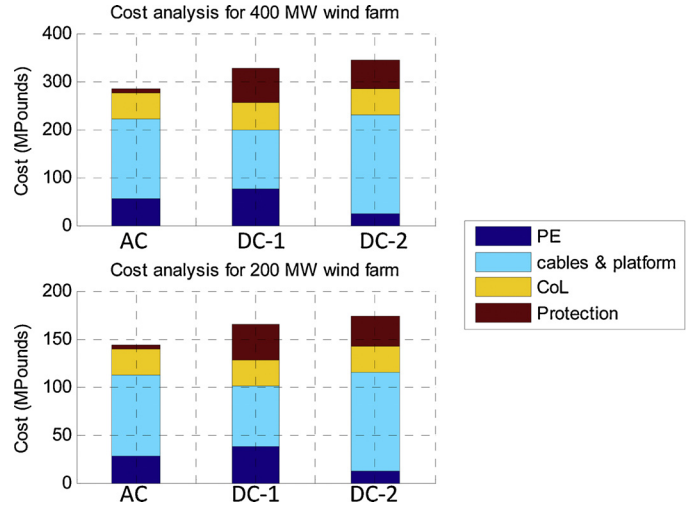

Fig. 6. Distribution of cost in AC and DC collection systems.

4.5. Cost of switch gear

The cost model for the medium voltage AC switch gear in [18] was used to calculate the cost of the AC switch gear.

$$C_{AC-switch \text{ gear}} = 1000(32.43 + 0.608V_n) \quad (13)$$

$V_n$  is the nominal voltage in kV and  $C_{AC-switchgear}$  the switchgear cost in £.

The cost of DC switch gear was assumed to be four times that of AC switch gear. This is an approximation based on [20] for the cost model of DC protective devices. The cost comparison results are sensitive to the uncertainty in the cost of DC switch gear.

4.6. Cost of losses

The annual energy losses estimated in Section 3 were used to obtain the cost of losses. It is estimated considering a life time ( $T$ ) of 20 years, interest rate ( $i$ ) of 10% and energy price as  $75 \text{ £/MWh}$  [14].

$$C_{\text{cost of losses}} = \text{hour} \times \text{energy price} \times \text{losses} \times \left( \sum_{i=0}^T \frac{1}{(1+i)^T} \right) \quad (14)$$

The results of the cost estimations are shown in Table 2. The cost distribution is shown in Fig. 6.

The maximum total investment costs of offshore wind farms based on the recently commissioned offshore wind farms are estimated as  $2.7 \text{ M£/MW}$  [21]. Excluding average investment costs of turbines and transmission cables [21], the investment cost estimation for the case of 400 MW AC collection systems will be 260–304 M£. The cost estimation for the 400 MW AC collection

**Table 3**  
Cost estimation 10 km collection cable length.

Case	Cost (M€)						Total cost (M€)
	Collection type	Turbine power electronics	Collection cables	Platform	Protection	Cost of losses	
400 MW	AC	55.44	131.27	101.70	8.40	55.22	352.03
	DC1	76.00	65.95	90.68	72.97	56.80	362.40
	DC2	24.00	65.95	172.38	61.76	56.00	380.09
200 MW	AC	27.72	65.63	52.05	4.20	27.44	177.04
	DC1	38.00	32.98	45.94	36.49	28.78	182.19
	DC2	12.00	32.98	87.09	30.88	28.05	191.00

systems using the above cost models, gives a total cost of 284.64 M€. This validates the AC collection systems cost estimation.

In the DC collection systems, the cost reduction obtained from the reduced cable size and the offshore platform were outweighed by the cost of DC protective devices and DC–DC converters. In DC2 configuration, the turbine power electronics cost is reduced because of removal of the individual converters in each turbine, but the transmission platform with platform DC converter and converter platform with the centralized DC converters increases the total platform cost. The higher cost of the DC2 configuration was due to the additional converter platform used.

However, the cost estimation for the DC collection systems is only approximate taking into account the sensitive factors and the assumptions used in the cost model. The total cost comparison results will be sensitive to the assumptions regarding the DC cable installation and platform cost ( $C_{inst-dc}$ ,  $C_{plat-dc}$ ), uncertainties in the DC switch gear cost and the length of the collection cables.

To illustrate this, a sensitivity study has been carried out for a collection cable length of 10 km using the same cost models described above and the results are shown in Table 3. The results show that the cost difference between the AC and DC collection systems reduces as the length of collection cables is increased. This shows that the cost comparison results of collection systems will be sensitive to the length of the collection cables. The short collection cable is a key reason for the relatively high cost of DC collection systems.

4.7. Reliability and maintenance cost

The maintenance cost can be classified into preventive and corrective maintenance cost. The preventive maintenance cost is associated with the energy losses due to planned maintenance, which causes partial or complete outages in the wind farms to prevent any possible damage of its components. The cost associated with the preventive maintenance losses is small because such maintenances are normally carried out during the period of low wind days when the energy yield is small.

The cost associated with the corrective maintenance losses is due to the unplanned nature of the maintenance, which occurs following the failure of the wind farm components. If these types of failure occur during adverse weather conditions, then unlike the preventive maintenance costs, the corrective maintenance costs can be expensive. The corrective maintenance cost can be estimated by performing a reliability analysis of the collection configurations considered. This would require the failure rates and repair times of the collection system components to estimate the Expected Energy Not Supplied (EENS) indices.

This corrective maintenance cost will be different for each of the collection systems considered because it depends on the failure rates and the repair time of the collection system components. The reliability data, such as the failure rates and repair times, are readily available for the AC collection systems from the experiences of the commissioned offshore wind farms [24], whereas such information is not available for the DC collection configurations, especially the

failure rates and repair times of DC–DC converters with the medium frequency transformers and DC circuit breakers, because of lack of operational experiences.

However, from the point of view of reliability, DC collection systems may not be a favourable choice as they depend more on power electronic converters and the failure rates of converters are higher than those of transformers, even though the reliability assessment has not been quantified. This will only result in a high maintenance cost for the DC collection systems, so including the maintenance cost will not affect the conclusion about the cost of DC collection systems.

4.8. Cost of protection and protection zones in DC collection systems

In all the collection systems considered for comparison, each wind turbine is provided with a circuit breaker, collection cables are considered to have one circuit breaker at each end of the cable and there is a platform circuit breaker. The protection zones for the DC collection systems are shown in Fig. 7. There will be high penalty for protection equipment in DC collection systems, which increases the total cost of the DC collection systems.

In case of meshed high voltage multi-terminal DC (MTDC) networks, DC faults can be handled by separating the DC network into different protection zones [25,26] using fewer DC circuit breakers as an alternative option to expensive DC circuit breakers, whereas this paper’s focus is on the comparison of the internal AC and DC collection systems, mainly with string configurations. There are limited options to determine zones to be protected or isolated.

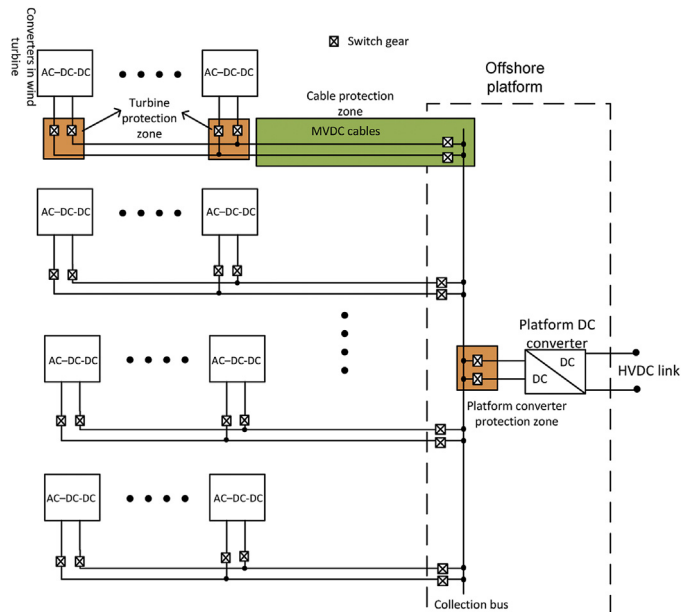

Fig. 7. Protection zones in DC collection systems.

**Table 4**  
Sensitivity of losses to higher values of collection bus voltage in DC1 case.

Collection type	Yearly energy losses (GWh)			Output energy (GWh)	Efficiency (%)
	Power electronics (including transformers)	Collection cables	Total		
AC	81.00 (7.18%)	2.74 (0.24%)	83.74 (7.42%)	1044.9	92.58
DC1 – 30 kV	83.76 (7.42%)	2.60 (0.23%)	86.36 (7.65%)	1042.3	92.35
DC1 – 40 kV	82.50 (7.31%)	1.67 (0.15%)	84.17 (7.46%)	1044.5	92.54

As seen in Fig. 7, one of the options is just to remove the DC circuit breakers provided for the individual turbines as marked by the turbine protection zone. This will reduce the cost of DC collection systems by 10%, making the costs of DC collection systems closer to the AC collection systems. However, this means any fault at one wind turbine output cable will force to disconnect the entire string (a total string capacity of 50 MW, 10 wind turbines each with 5 MW rating) of wind turbines and to lose more power than an individual wind turbine power output loss when provided with a DC circuit breaker.

## 5. Effect of DC bus collection voltage

In conventional AC collection configurations, the collection bus and the transmission voltages are normally chosen based on the availability of protection devices. The benefit of moving the AC inter-array voltage from 33 kV to higher voltages for large offshore wind farms is discussed in [22,23]. The DC collection systems and protective devices [20] are still in the research stage and the use of DC–DC converters opens up the possibility of using different collection bus voltages.

The economic assessment in Section 4 shows that the DC1 configuration was cost effective compared to the DC2. In this section, the effect of a high collection bus voltage on the losses is considered for the 400 MW wind farm DC1 case. A collection bus voltage of 40 kV is chosen for this sensitivity study and the losses are analysed for the DC1 case.

A higher value of collection bus voltage will give lower losses in the collection cables and reduce the high amount of current to be handled by the turbine side and main DC–DC converters. The results of loss estimation with a higher value of collection bus voltage are shown in Table 4. With a higher collection bus voltage, as expected the losses in the cables were reduced from 0.23% for the 30 kV collection bus voltage to 0.15% for the 40 kV collection bus. The power electronic losses are slightly reduced because of the reduced current in the DC–DC converters. It resulted in a 0.19% reduction in total losses for the 40 kV case compared to the 30 kV case of DC1 configuration.

The results show that, with a higher collection bus voltage, efficiency of DC collection systems can become closer to that of AC collection systems. However, this is based on the availability of DC–DC converters with high voltage transformation ratios which are currently not available.

## 6. Conclusion

A comparative study of losses and cost of AC and DC collection systems has been carried out. The results show that the losses in the DC collection systems are higher than in AC collection systems. The increase in the losses of DC collection systems is mainly contributed by the DC–DC converters. In the AC collection systems, reactive power does not significantly increase the collection cable losses due to the relatively shorter AC collection cables. With a higher collection bus voltage, the efficiency of the DC collection systems increases. However, this is based on the availability of DC–DC converters with high voltage transformation ratios, which are not available presently.

The economic comparison results show that the cost of DC collection systems is higher than that of AC collection systems. The costs of high power DC–DC converters and DC switch gear are identified as the main contributors to the cost of DC collection systems. The cost reductions achieved by the reduced size of DC cables and offshore platform are outweighed by the cost of DC protective devices and DC–DC converters.

The DC collection configuration which uses centralized DC converters has lower losses than the DC collection configuration with the individual converters on each turbine. However, the additional converter platforms increase the total cost of the DC collection systems with the centralized converters.

DC collection systems do not necessarily reduce the power conversion stages compared to the AC collection systems. So it is not possible to expect a decrease in losses and cost as far as the conversion stages are concerned. A reduced power conversion stage is possible only with turbines of higher ratings and DC–DC converters with a high voltage transformation ratio.

## Acknowledgement

This work was supported by Engineering and Physical Sciences Research Council (EPSRC) under the project Enhanced Renewable Integration through Flexible Transmission Options (ERIFT) programme under Grant EP/K006312/1.

All data created during this research are openly available via the Cardiff University data catalog at <http://dx.doi.org/10.17035/d.2015.100106>.

## References

- [1] G. Quinonez-Varela, G. Ault, O. Anaya-Lara, J. McDonald, Electrical collector system options for large offshore wind farms, *IET Renew. Power Gener.* 1 (June (2)) (2007) 107–114.
- [2] C. Zhan, C. Smith, A. Crane, D. Grieve, DC transmission and distribution system for a large offshore wind farm, in: *Proc. IET AC and DC Power Transmission*, 2010.
- [3] C. Meyer, M. Hoing, A. Peterson, R.W. De Doncker, Control and design of DC grids for offshore wind farms, *IEEE Trans. Ind. Appl.* 43 (6) (2007) 1475–1482.
- [4] L. Max, S. Lundberg, System efficiency of a DC/DC converter-based wind farm", *Wind Energy* 11 (1) (2008) 109–120.
- [5] C. Meyer, R.W. De Doncker, Design of a three-phase series resonant converter for offshore DC grids, in: *Proc. IEEE Ind. Appl. Soc. Conf.*, 2007, pp. 216–223.
- [6] J. Robinson, D. Jovcic, G. Joós, Analysis and design of an offshore wind farm using a MV DC grid, *IEEE Trans. Power Deliv.* 25 (October (4)) (2010) 2164–2173.
- [7] N. Denniston, A. Massoud, S. Ahmed, P. Enjeti, Multiple module high gain high voltage DC–DC transformers for offshore wind energy systems, *IEEE Trans. Ind. Electron.* 58 (5) (2011) 1877–1886.
- [8] D. Jovcic, Step-up DC–DC converter for megawatt size applications, *IET Power Electron.* 2 (6) (2009) 675–685.
- [9] N. Holtmark, H.J. Bahirat, M. Molinas, B.A. Mork, H.K. Høidalen, An all-DC offshore wind farm with series-connected turbines: an alternative to the classical parallel AC model? *IEEE Trans. Ind. Electron.* 60 (June (6)) (2013) 2420–2428.
- [10] M. Alexander Parker, O. Anaya-Lara, Cost and losses associated with offshore wind farm collection networks which centralise the turbine power electronic converters, *IET Renew. Power Gener.* 7 (4) (2013) 390–400.
- [11] H. Bahirat, B.A. Mork, H.K. Høidalen, Comparison of wind farm topologies for offshore applications, in: *Proc. IEEE PES Gen. Meeting*, July 2012, pp. 1–8.
- [12] L. Max, Design and control of a DC collection grid for a wind farm (Ph.D. dissertation), Dept. Energy Environ., Chalmers University of Technology, Sweden, 2009.
- [13] D. Graovac, M. Purschel, IGBT Power Losses Calculation Using the Data-Sheet Parameters Application Note, v1.1, Application Note, Infineon Technologies AG, January 2009.

- [14] Working Group B4-46, Voltage Source Converter (VSC) HVDC for power transmission – economic aspects and comparison with other AC and DC technologies, in: CIGRE, April 2012.
- [15] S. Meier, et al., Design considerations for medium frequency power transformers in offshore wind farms, 2009.
- [16] XLPE Submarine Cable Systems, ABB, 2010.
- [17] G. Stamatiou, Techno-economical analysis of DC collection grid for offshore wind parks (Master's thesis), University of Nottingham, 2010.
- [18] M. Dicorato, G. Forte, M. Pisani, M. Trovato, Guidelines for assessment of investment cost for offshore wind generation, *Renew. Energy* 36 (8) (2011) 2043–2051.
- [19] S. Lundberg, Performance comparison of wind park configurations, Chalmers University of Technology, Department of Electric Power Engineering, Sweden.
- [20] C. Meyer, Key Components for Future Offshore DC Grids (Ph.D. thesis), RWTH Aachen.
- [21] The economics of wind energy. Technical report, European Wind Energy Association (EWEA), March 2009.
- [22] A. Ferguson, P. de Villiers, B. Fitzgerald, J. Matthesen, Benefits in moving the inter-array voltage from 33 kV to 66 kV AC for large offshore wind farms, in: EWEA Annual Event, Copenhagen, April, 2012.
- [23] D. Saez, J. Iglesias, E. Gimenez, M. Reza, I. Romero, Evaluation of 72 kV collection grids on offshore wind farms, in: EWEA Annual Event, Copenhagen, April, 2012.
- [24] Offshore wind experiences, a bottom up review of 16 projects, Ocean Wind, Technical Report, 2010.
- [25] J. Wang, B. Berggren, K. Linden, J. Pan, R. Nuqui, Multi-terminal DC system line protection requirement and high speed protection solutions, CIGRE 2015, Lund.
- [26] L. Tang, B.T. Ooi, Protection of VSC-multi-terminal HVDC against DC faults, in: IEEE 33rd Annual Power Electronics Specialists Conference, 2002.
- [27] <http://www.bard-offshore.de>