



Dynamics and Vibroacoustics of Machines (DVM2014)

The next generation of fluid power systems

Milos Vukovic*, Hubertus Murrenhoff

*Institute for Fluid Power Drives and Controls, RWTH Aachen University
Steinbachstraße 53, Aachen
52074 Germany*

Abstract

Over the past half century the fluid power community has seen the development of a number of new energy efficient components. Despite these improvements on the component level many hydraulic systems still remain inefficient. These losses are mainly due to two reasons. The first relates to economic factors as more efficient systems are usually considerably more expensive. The second reason is poor system designs that frequently force efficient components to operate in regions of low efficiency. The Institute for Fluid Power Drives and Controls (IFAS) in Aachen, Germany is one of a number of institutes worldwide aiming to change this trend in order to secure the future of fluid power in industry. IFAS has not only focused on the development of new cost-effective architectures but also on holistic design methodologies aimed at assisting engineers in the design of efficient hydraulic systems. One further strategy has been to enter new fields of application, where the attributes of hydraulic systems, previously considered to be disadvantages, actually become advantages. An example of such a field is the renewable energy sector, where hydraulic drivetrains for wind, wave and marine current power are currently under development. This paper gives insight into these new developments and briefly summarizes the research into new hydraulic systems currently being conducted at IFAS.

© 2015 The Authors. Published by Elsevier Ltd. This is an open access article under the CC BY-NC-ND license (<http://creativecommons.org/licenses/by-nc-nd/4.0/>).

Peer-review under responsibility of organizing committee of the Dynamics and Vibroacoustics of Machines (DVM2014)

Keywords: Fluid power systems; mobile hydraulics; drivetrains for renewable energies; design methodologies

* Corresponding author. Tel. +49-241-80-27528; fax: +49-241-80-22194.

E-mail address: milos.vukovic@ifas.rwth-aachen.de

1. Introduction

To ensure the competitiveness of hydraulic systems with their electromechanical counterparts it is necessary not only to develop more energy efficient architectures but also to ensure these architectures are cost efficient. Only the combination of these two factors will lead to acceptance by industry and consumers. The key to a significant increase in energy efficiency is not to be found in improvements on the component level but rather on the system level. This key issue is frequently encountered in industry where despite using optimized components the overall system still remains inefficient. An example hereof is the field of mobile hydraulics. Although the peak efficiency of a typical diesel engine is around 40 % and that of the hydraulic system can even reach 80 %, the typical total system efficiency of such machines is approximately ten percent, meaning that only ten percent of the chemical energy stored in the fuel is converted into useful mechanical power. As shown in Figure 1 this is in part due to the inefficient operating point of the internal combustion engine (average efficiency of 25 %), the losses in the hydraulic pumps and increased throttling losses across the proportional valves (average hydraulic efficiency of 40 %).

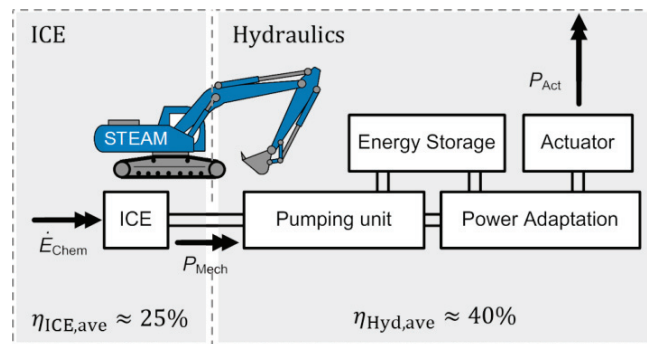

Fig. 1. Schematic representation of mobile hydraulic system.

The key to cost efficiency is to use simple hydraulic components and to migrate the system intelligence away from the hydraulic hardware and into the system software. Such layouts are frequently referred to as electrohydraulic architectures. This introduces flexibility and allows for rapid prototyping. IFAS has focused on developing intelligent hydraulic systems and design methodologies not only for already established applications, such as earth moving machinery, but also in new fields like renewable energies. The paper starts by introducing some of the classification and design procedures developed with the aim of helping engineers design better systems. This is followed by a discussion of a new mobile hydraulic system and a drivetrain for wind power applications.

Nomenclature

HST	Hydrostatic Transmission
IFAS	Institute for Fluid Power Drives and Controls
ICE	Internal Combustion Engine
η	Efficiency

2. System classification and design

To develop new and improved hydraulic architectures it is first necessary to understand current systems and to be able to classify them. Back in the seventies Backé at IFAS introduced the well-known quadrants of operation, according to the supply (flow or pressure impressed) and control concepts (valve or displacement control) [1]. These are illustrated in Figure 2(a). In those years machines utilizing architectures from the quadrants I-III were already widespread. Using this systematic classification it soon became clear the systems from the fourth quadrant did not exist, that is displacement controlled motors operating in a constant pressure system. As a result, in the eighties

Murrenhoff, also at IFAS, tested and developed such systems, which lead to considerable improvements in efficiency [3]. This example illustrates the importance of being able to classify systems as this can aid understanding and lead to new developments. In the last twenty years, a number of new hydraulic components have been introduced in literature. These include hydraulic transformers, digital displacement units, buck converters and multi-chamber cylinders [4, 5]. Fitting these new possibilities into the established four quadrants proves difficult. Therefore, in 2014, IFAS introduced a new classification scheme implementing a barcode, see Figure 2(b) [6]. The new barcode is mainly aimed at mobile hydraulic systems but can be used for standard industrial hydraulic systems as well. Using the barcode it is possible to classify and design systems using both digital and analogue supply and control concepts, as well as to identify systems capable of recovering energy, either through recuperation or regeneration. This will help engineers improve already existing circuits and discover new possibilities. For more details concerning the new classification scheme refer to [6].

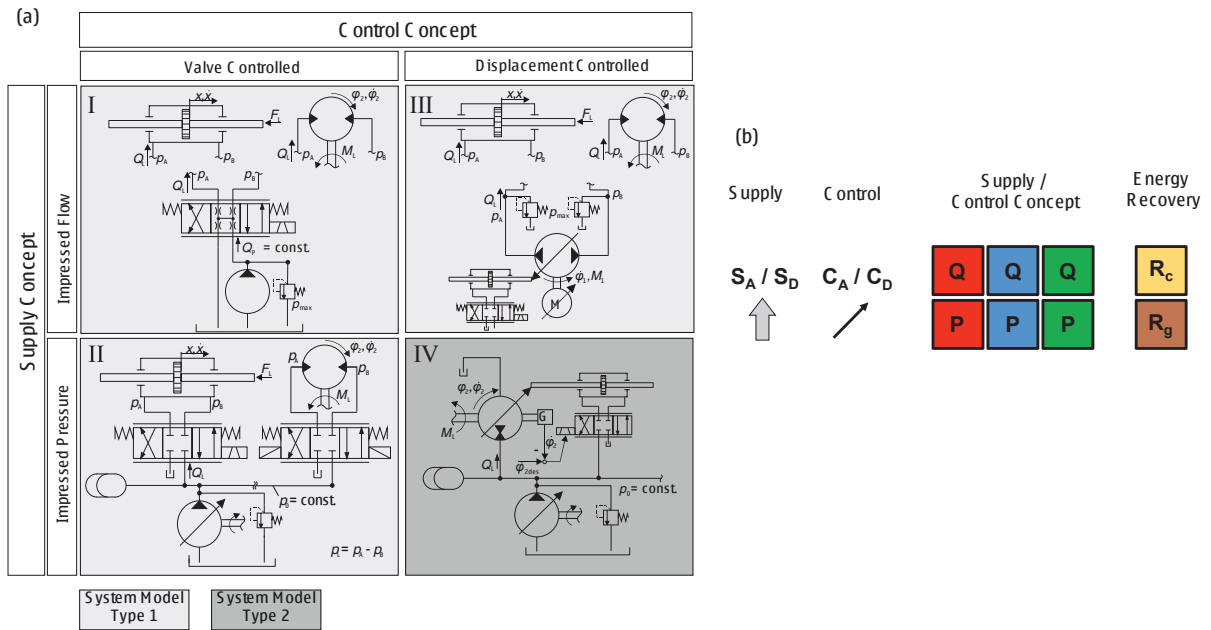

Fig. 2. (a) Hydraulic system classification [2]; (b) Hydraulic system classification barcode [6].

3. Efficient mobile hydraulic systems

Due to their excellent power density, cost effective realization of linear movements using differential cylinders and robustness, hydraulic systems are extensively used in mobile machinery. The next generation of efficient mobile machinery must aim to improve the hydraulic system efficiency while at the same time optimizing the operating point of the internal combustion engine. This means that a holistic design approach is necessary. Furthermore, the ability to recover potential and kinetic energy is becoming ever more important. This is related to the fact that certain mobile machines, excavators for example, perform frequent cyclic motions due to the kinematic arrangement of their actuators, Figure 3.

This means every time the arm is lifted it must eventually be lowered and every time the swing drive is accelerated it must eventually be decelerated. As a result, such machines have great potential when it comes to energy recovery. IFAS has risen to the challenge by developing the STEAM mobile hydraulic system [7]. Unlike other designs, this architecture is based on a holistic design approach, which considers both the hydraulic circuit and the ICE.

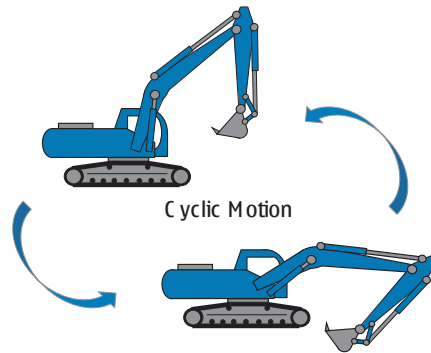

Fig. 3. Cyclic movements of excavator.

An advantage of STEAM is that simple off-the-shelf components are used and the system intelligence is no longer placed in the hydraulic hardware but rather in the control software, Figure 4(a). The system can be thought of as a hydraulic hybrid. The ICE and pump are only used to supply the average power demand, while the hydraulic accumulators are used for peak power requirements. By using a fixed displacement pump in combination with a constant pressure system, the engine always experiences a constant load allowing it to operate efficiently. In addition to the high pressure system (HP), supplied by the pump, a medium pressure rail (MP) is introduced to minimize the throttling losses across the valves. To convince industry of the system's potential advantages it is currently being installed into an 18 t wheeled excavator shown in Figure 4(b). For more details concerning the new system and its operation refer to [7, 8].

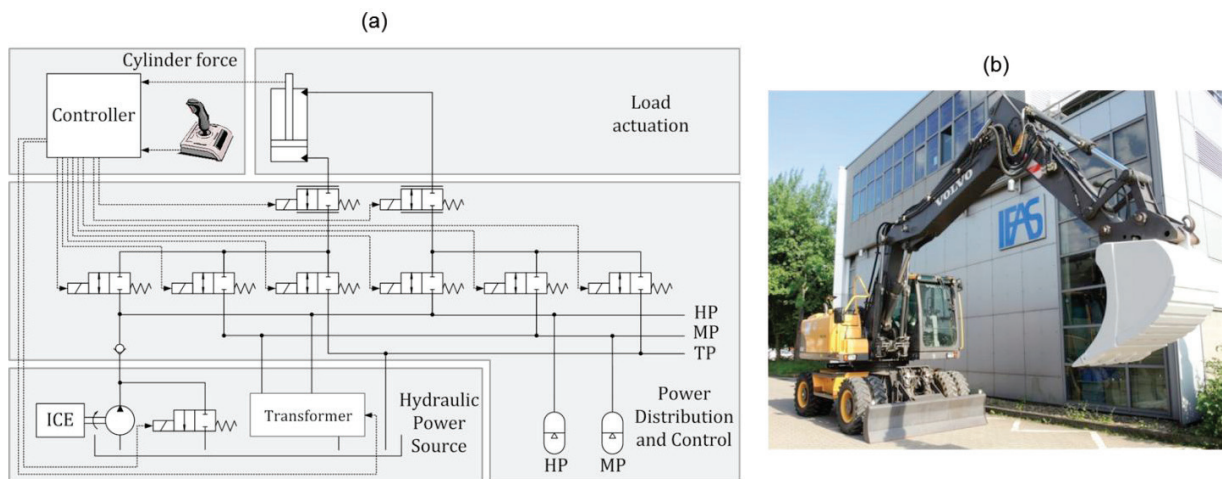

Fig. 4. (a) STEAM mobile hydraulic system [8]; (b) 18 t demonstrator machine [8].

4. Drivetrains for renewable energies

The lower stiffness of hydraulic systems compared to electromechanical systems has always been regarded as a disadvantage as this leads to lower control accuracy and disturbance rejection. As a result the majority of drives in modern machine tools are no longer hydraulically actuated. In the field of wind power decreased load stiffness is actually desirable. This allows the drivetrain to absorb the energy generated by powerful gusts of wind or by sudden loads from the electric grid, which could otherwise lead to the mechanical damage of gearbox components. This attribute coupled with their inherent continuously variable transmission ratio makes hydrostatic transmissions (HST)

ideal for wind power without the requirement of a frequency converter. The basic layout of such a system is shown below in Figure 5.

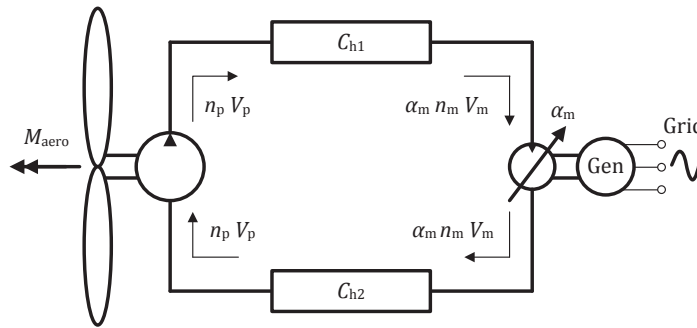

Fig. 5. Basic layout of a HST for wind power [9].

Basically, the HST transfers the rotor power P_{Rotor} to the generator while transforming the constant generator speed n_{Gen} into the required rotor speed n_{Rotor} . The rotor speed is regulated using the motor's displacement setting α_m . Low wind speeds require low displacement settings as less flow is generated by the rotor, while higher wind speeds generate more flow and require larger motor displacements. As a result of this variable power input, the system's efficiency will change according to the wind speed. Below the rated speed all the components will operate at part load conditions leading to decreased efficiency.

To ensure good efficiency throughout the wind speed range a switched displacement HST for a 1 MW turbine has been developed at IFAS, see Figure 6(a). The new architecture allows individual pumps and motors to be switched on and off depending on the current operating point. Two fixed displacement pumps convert the wind power into hydraulic power in the form of pressurized fluid. Two sets of motors are then used to drive two generators. Each component, except for the smallest pump, can be switched to idle mode, which allows different pump-motor combinations for different operating points. By allowing individual pumps and motors to be switched on and off depending on the current operating point the new architecture leads to an improved system efficiency throughout the operating range, see Figure 6(b).

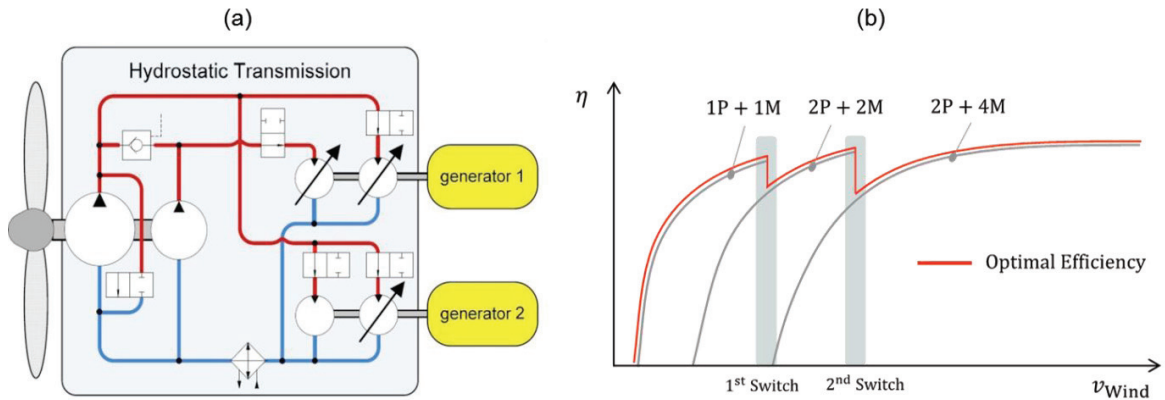

Fig. 6. (a) Switched displacement HST [10]; (b) Overall system efficiency.

Figure 7 depicts the setup used for system validation at IFAS. The test bench is divided into two sides: the actual transmission, on the right hand side (RHS), and an additional drivetrain on the left hand side (LHS). To avoid having to connect the system directly to the grid a circular set-up is used. The power generated on the RHS is

circulated back into the LHS. The two electric motors supply the system with additional power in order to make up for the losses incurred during operation. For more details regarding the system and test bench refer to [9, 10].

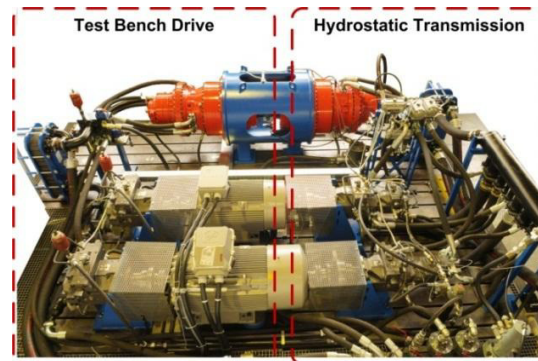

Fig. 7. 1 MW wind turbine test bench at IFAS [10].

5. Conclusion and Outlook

This paper has shown that to achieve considerable improvements in energy efficiency it is necessary to develop new hydraulic system architectures that allow components to operate in regions of high efficiency. To aid in the design process IFAS has developed a systematic classification barcode, which includes both standard analogue and new digital hydraulic components. In addition, two key research projects characterizing this next generation of fluid power systems were presented. The first is a mobile hydraulic system for excavators, called STEAM, which is based on a holistic design approach. The second system, a switched displacement hydrostatic transmission for wind turbines, is an example of a new application field, where a specific system property, in this case the load stiffness, previously considered to be a disadvantage now becomes an advantage.

References

- [1] Backé, W., Servohydraulik, Lecture notes, IFAS RWTH Aachen, 1975.
- [2] Murrenhoff, H., Servohydraulik – Geregelt-te hydraulische Antriebe, Lecture notes, Shaker Verlag, 2012.
- [3] Murrenhoff, H. Regelung von verstellbaren Verdrängereinheiten am Konstantdrucknetz, PhD thesis RWTH Aachen, 1983.
- [4] Achten, P., Palmberg, J., “What a difference a hole makes – the commercial value of the Innas hydraulic transformer”, Proceedings of the 6th Scandinavian International Conference on Fluid Power, Tampere, Finland, 1999.
- [5] Scheidl, R., Kogler H., “Hydraulische Schaltverfahren - Stand der Technik und Herausforderungen“, O+P Journal 2, 2013.
- [6] Murrenhoff, H., Sgro, S., Vukovic, M., “An Overview of Energy Saving Architectures for Mobile Applications”, Proceedings of the 9th International Fluid Power Conference, Aachen, Germany, 2014.
- [7] Vukovic, M., Sgro, S., Murrenhoff, H., “STEAM – a mobile hydraulic system with engine integration”, Proceedings of the ASME/BATH 2013 Symposium on Fluid Power & Motion Control, FPMC2013, Sarasota, Florida, USA, 2013.
- [8] Vukovic, M., Murrenhoff, H., “STEAM – a holistic approach to designing excavator systems”, Proceedings of the 9th International Fluid Power Conference, Aachen, Germany, 2014.
- [9] Schmitz, J., Vukovic, M., Sgro, S., Murrenhoff, H., “Hydrostatic transmission for wind turbines – an old concept new dynamics”, Proceedings of the ASME/BATH 2013 Symposium on Fluid Power & Motion Control, FPMC2013, Sarasota, Florida, USA, 2013.
- [10] Schmitz, J., Diepeveen, N., Vatheuer, N., Murrenhoff, H., Dynamic Transmission Response of a Hydrostatic Transmission measured on a Test Bench. Proceedings of EWEA Conference, Copenhagen, Denmark, 2012.