

Available online at www.sciencedirect.com**ScienceDirect**

Procedia Engineering 87 (2014) 1123 – 1126

**Procedia
Engineering**www.elsevier.com/locate/procedia

EUROSENSORS 2014, the XXVIII edition of the conference series

An ionic liquid based strain sensor for large displacements

Grim Keulemans*, Patrick Pelgrims, Marko Bakula, Frederik Ceysens, Robert Puers

KU Leuven, ESAT-MICAS, Kasteelpark Arenberg 10, 3001 Heverlee, Belgium

Abstract

A novel ionic liquid based strain sensor is fabricated for high strain measurements (up to 10% and higher). A tubular silicone microchannel with a diameter of 310 μm and a length of 5 mm is filled with an ionic liquid (1-Butyl-1-methylpyrrolidinium bis(trifluoromethylsulfonyl)imide). The final sensor has an outer diameter of 650 μm and a length of 15 mm. When the channel is axially loaded, geometrical deformations change the electrical properties of the liquid channel. 4-point impedance spectroscopy with the integrated circuit AD5933 from Analog Devices and a dedicated galvanostatic front-end is performed to characterize this piezoresistive effect. The highest sensitivity is observed in the frequency range from 10 to 25 kHz, with corresponding gauge factors between 2 and 2.5 for an elongation of 10%.

© 2014 Published by Elsevier Ltd. This is an open access article under the CC BY-NC-ND license (<http://creativecommons.org/licenses/by-nc-nd/3.0/>).

Peer-review under responsibility of the scientific committee of Eurosensors 2014

Keywords: Strain sensor; PMDS; Microchannel; Ionic liquid; AD5933; Impedance spectroscopy

1. Introduction

Large displacement measurements in biomedical applications (tendon strain, joint displacement, ...) and robotics (displacement of grippers, pneumatic and hydraulic actuators) require small flexible strain sensors. Traditional strain gauges (constantan, nickel-chromium or silicon) have a limited flexibility and are not suitable for these applications. Recent developments in large strain sensors have looked into intrinsically conductive polymers, conductive filler-doped elastomers [1], liquid metal alloy based sensors (mercury, Galinstan or EGaln [2,3]) and glycerin with aqueous sodium chloride based sensors [4,5]. Previous research revealed that conductive filler-doped elastomers suffer from significant non-linearity and hysteresis at larger strains [1,5]. Liquid metal alloys have a high intrinsic conductivity, which results in small resistance variations and bad electrical performance. In contrast, the mixture of

* Corresponding author. Tel.: +32 16 321105; fax: +32 16 321975.
E-mail address: grim.keulemans@esat.kuleuven.be

glycerin with aqueous sodium chloride based strain sensors can be tailored such that the strain sensor has the desired resistivity (\sim kohm). However, evaporation of the saline solution jeopardizes its reliability [4]. In this research, a new straightforward fabrication process of an ionic liquid filled silicone channel is proposed. This ionic liquid (see Fig. 1) has a lower evaporation rate and avoids the liquid void problem [6].

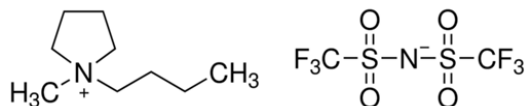

Fig. 1. The chemical structure of 1-Butyl-1-methyl-pyrrolidinium bis(trifluoromethylsulfonyl)imide

2. Design

An ionic liquid is enclosed in a tubular silicone microchannel with an initial length (l_0) and diameter (d_0), as displayed in Fig. 2.a. When axial strain is applied to the sensor, the length of the microchannel ($l_0 + \Delta l$) will increase, whereas the cross-sectional area of the channel ($d_0 + \Delta d$) will decrease (necking), as shown Fig. 2.b. As a result, the channel impedance ($Z_{ion}(\omega)$) will increase when the sensor is axially elongated. This impedance change should be monitored by an AC measurement, as a DC bias applied over the liquid channel might result in charge separation and electrolysis of the ionic liquid.

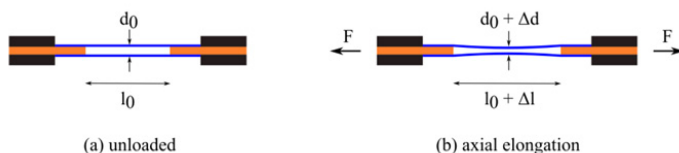

Fig. 2. Fluidic strain sensor principle

3. Experimental

The fabrication process starts by filling a medical grade silicone tube (DOW Corning Q7-4750) from HelixMark with the ionic liquid by means of a syringe. Afterwards, Teflon coated copper electrodes are inserted into both ends of the tube. The silicone channel (diameter of $310 \mu\text{m}$ and length of 5 mm) is sealed with medical grade epoxy (Epotek 302M) and cured overnight. The final packaged ionic liquid strain sensor has an outer diameter of $650 \mu\text{m}$ and a length of 15 mm and is shown in Fig. 3.

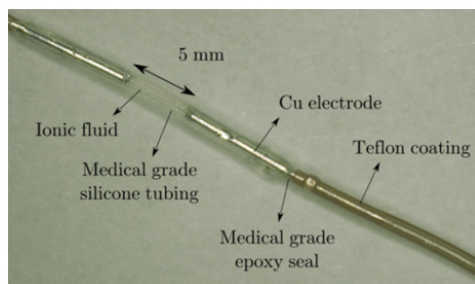

Fig. 3. The ionic liquid based strain sensor

To characterize the piezoresistive behavior of the strain sensor, 4-point electrical impedance spectroscopy [7] is performed at different mechanical loads. A compact read-out is developed based on the AD5933 integrated circuit [8] from Analog Devices: a 1MSPS, 12-bit impedance converter, network analyzer. In order to perform 4-point impedance measurements instead of the more basic 2-point measurement from the AD5933, a dedicated galvanostatic front-end [9] with a Howland current generator and a difference amplifier is implemented (see Fig. 4). The circuit compensates for DC offset and lead wire impedance and increases the load drive current.

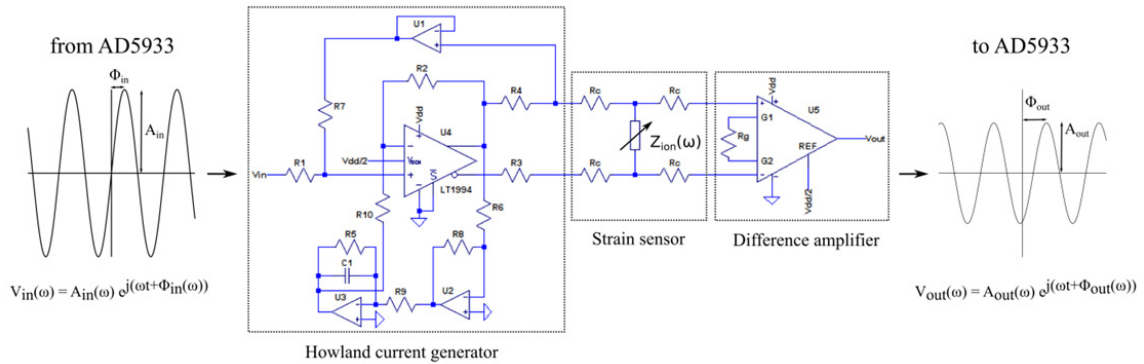

Fig. 4. Schematic diagram of the dedicated galvanostatic front-end for 4-point impedance measurements with the AD5933 microchip (Howland current generator, strain sensor and difference amplifier)

4. Results

Initial impedance magnitudes in hundreds of kohm are observed. In Fig. 5, the real and imaginary part of the strain sensor impedance are plotted as function of frequency for applied elongations up to 10%. The increased impedance at lower frequencies is due to the double layer at the electrodes. The maximum sensitivity is detected in the frequency range from 10 to 25 kHz. In Fig. 6, the change in the real part of the impedance versus applied strain is depicted for four frequencies in this range. As seen, the piezoresistive behavior is linear at these frequencies. Gauge factors $((\Delta R/R_0)/(\Delta l/l_0))$ between 2 and 2.5 are obtained.

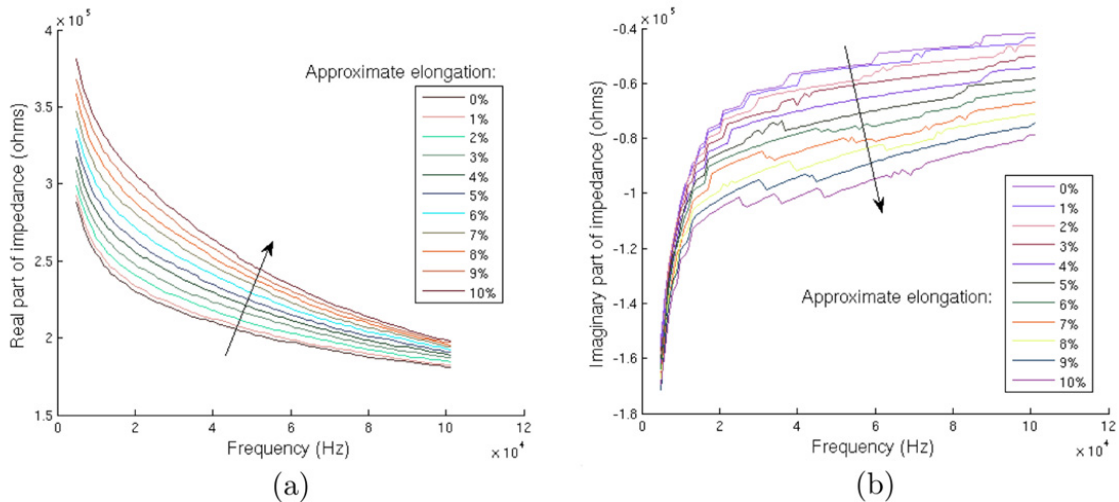

Fig. 5. Real part (a) and imaginary part (b) of strain sensor impedance as function of frequency and elongation.

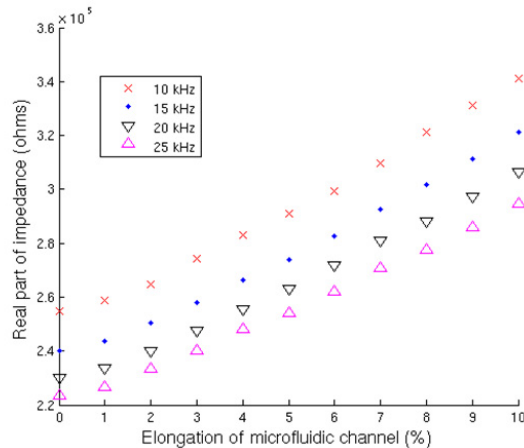

Fig. 6. Change in the real part of sensor impedance as function of channel elongation (up to 10%) at 10 kHz, 15 kHz, 20 kHz and 25 kHz.

4. Conclusion

A straightforward, low cost packaging technology for an ionic liquid based strain sensor is proposed. A printed circuit board sized 4-point impedance spectroscopy technique is developed based on the AD5933 integrated circuit from Analog Devices. Together, they enable the application of ionic liquid strain sensing in small-scale sensor modules in the biomedical and robotics field. Further work will focus on characterizing the thermal and dynamic behavior of the sensor and solving possible biocompatibility issues (selection of ionic fluid and packaging of sensor and read-out circuitry).

Acknowledgements

Research funded by a Ph. D. grant of the Agency for Innovation by Science and Technology (IWT) and the ERC-2013-AG, μ Thalys, grant agreement No. 340931 of the European Commission.

References

- [1] T. Yamada, Y. Hayamizu, Y. Yamamoto, Y. Yomogia, A. Izadi-Najafabadi, D.N. Futaba, K. Hata, A stretchable carbon nanotube strain sensor for human-motion detection, *Nature nanotechnology*. 6 (2011) 296-301.
- [2] S. Cheng, W. Zhigang, A Microfluidic, Reversibly Stretchable, Large-Area Wireless Strain Sensor, *Advanced Functional Materials*. 21 (2011) 2282-2290.
- [3] Y.-L. Park, B.-R. Chen, and R.J. Wood, Design and fabrication of soft artificial skin using embedded microchannels and liquid conductors, *IEEE Sensors Journal*. 12 (2012) 2711-2718.
- [4] Y.-N. Cheung, Y. Zhu, C.-H. Cheng, C. Chao and W. Leung, A novel fluidic strain sensor for large strain measurements, *Sensors and Actuators A*, 147 (2008) 401-408.
- [5] J.-B. Chossat, Y.-L. Park, R. J. Wood, V. Duchaine, A Soft Strain Sensor Based on Ionic and Metal Liquids, *IEEE Sensors Journal*. 13 (2013) 3405-3414.
- [6] Y. Zhu, C. Chao, C.-H. Cheng, W. Leung, A novel ionic-liquid strain sensor for large-strain applications, *IEEE Electron Device Letters*. 30 (2009) 337-339.
- [7] F. Seoane, J. Ferreira, J. Sánchez and R. Bragós, An analog front-end enables electrical impedance spectroscopy system on-chip for biomedical applications, *Physiological Measurement*, 29 (2008) 267-278.
- [8] Analog Devices, AD5933: 1 MSPS, 12 bit impedance converter network analyzer, http://www.analog.com/static/imported-files/data_sheets/AD5933.pdf
- [9] U. Pliquette, M. Schönfeldt, A. Barthel, D. Frense, T. Nacke and D. Beckmann, Front end with offset-free symmetrical current source optimized for time domain impedance spectroscopy, *Physiological Measurement*, 32 (2011) 927-944.