

Available online at www.sciencedirect.com**SciVerse ScienceDirect**

Procedia Engineering 47 (2012) 821 – 824

**Procedia
Engineering**www.elsevier.com/locate/procedia

Proc. Eurosensors XXVI, September 9-12, 2012, Kraków, Poland

A Hybrid FinFET-based Biosensor with Integrated Readout Capability

Paolo Livi^a *, Sara Rigante^b, Yihui Chen^a, Adrian Ionescu^b, Andreas Hierlemann^a^aBioengineering Laboratory, Department of Biosystems Science and Engineering, ETH Zurich, Mattenstrasse 26, Basle, CH-4058, Switzerland^bNanoelectronic Devices Group (NANOLAB), EPFL, Lausanne, CH-1015, Switzerland

Abstract

We report on two circuits built with hybrid FinFETs [1], capable of both sensing and signal conditioning. The first circuit is a ring oscillator, whose oscillating frequency depends on the analyte concentration, i.e., on the voltage drop in the liquid. The second is a pseudo-differential amplifier for differential measurements with tunable gain. To the best of our knowledge, no FinFET-based circuits featuring both, biosensing and readout have been reported on so far.

© 2012 The Authors. Published by Elsevier Ltd. Selection and/or peer-review under responsibility of the Symposium Cracoviense Sp. z.o.o. Open access under [CC BY-NC-ND license](http://creativecommons.org/licenses/by-nc-nd/4.0/).

Keywords: Nanowires; biosensing; FinFET; readout circuit

1. Introduction

The large surface-to-volume ratio of FinFETs entails high sensitivity, rendering them suitable for biosensing. The output signals of these sensors are typically weak and noisy; it is thus crucial to have an efficient readout circuit close to the sensor.

We realized such a system with the hybrid FinFET presented in [1], capable of sensing as well as having the electrical properties of a Double-Gate (DG)-MOSFET. This way, the high sensitivity of FinFETs can be combined with the excellent electrical properties of a DG-MOSFET, which include better channel control, reduced short channel effects, improved I_{ON}/I_{OFF} ratio.

A cross section of the device is shown in Fig. 1a: A partially gated FinFET with the top surface exposed to liquid. The structure is equivalent to a parallel arrangement of a sensing and a driving

* Corresponding author. Tel.: +41613873234 ; fax: +41613873994.

E-mail address: paolo.livi@bsse.ethz.ch.

transistor (Fig. 1c). The device has been previously designed using three-dimensional Technology CAD (TCAD) Finite Element Simulations and then modeled with Verilog-A [2]. This enables simulations using commercial Electronic Design Automation (EDA) tools. Figure 1c shows the $I_d(V_g)$ curve of the device. The model includes a drain current variation due to a pH-dependent voltage variation: $V_{liq}(pH) \approx -2.3\alpha(kT/q)(pH-pH_{pzc})$, yielding around 40mV/pH ($\alpha \approx 0.7$). The same device can also be used as a DG-MOSFET by covering the top surface (Fig. 1b). The symbols of the two devices are shown in Fig. 1a and Fig. 1b. It is worth mentioning that by using a different equation for the voltage variation, V_{liq} , other biosensing events can be simulated as well, such as a protein binding on the sensor surface.

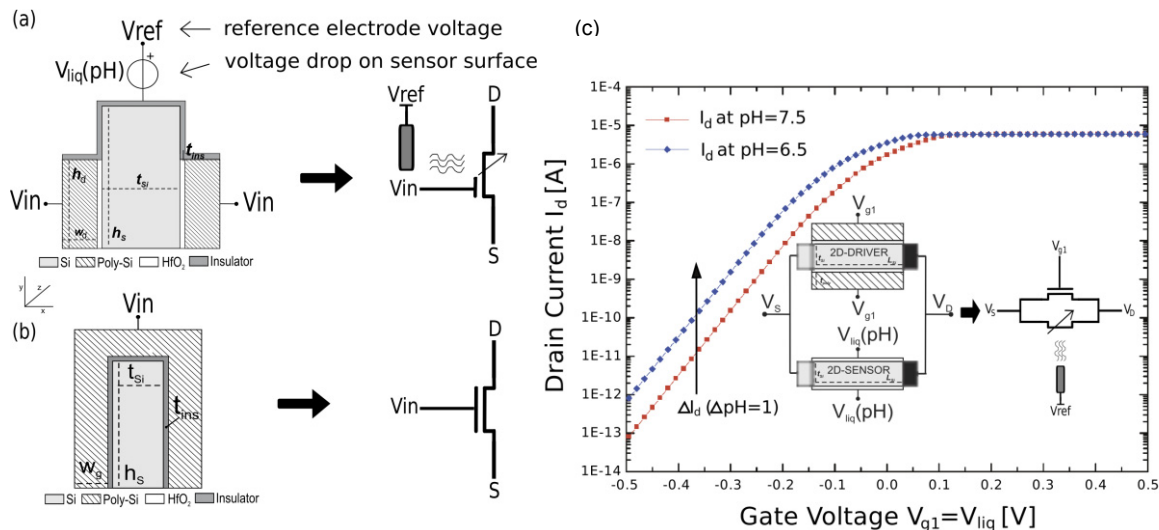

Fig. 1. Cross section of a hybrid device (a) and a double-gate MOSFET (b) with corresponding symbols. (c) $I_d(V_g)$ curve for different pH-values and associated modeling approach.

2. Ring oscillator

Fig. 2a shows the first proposed circuit, a three-stage ring oscillator, whose oscillating frequency depends on the pH (i.e., on the voltage drop in the liquid on the sensor surface). This is achieved with the inverter scheme in the inset of Fig. 2a: The DG-MOSFET is used as the driving transistor, while the hybrid FinFET is connected as load. The advantage of the hybrid device is that the driving transistor is used as a depletion-mode transistor load. This has two main advantages: The output voltage can be equal to V_{DD} , and a steeper ON-OFF transition can be achieved even with a small transistor lengths ratio (L_2/L_1). The sensor part, instead, modulates the current flowing through the inverter. The time needed to charge the capacitances in between the inverters is then changed, finally affecting the oscillating frequency. Fig. 2b shows a simulation result of this behavior with a good linearity between pH 2 and 10.

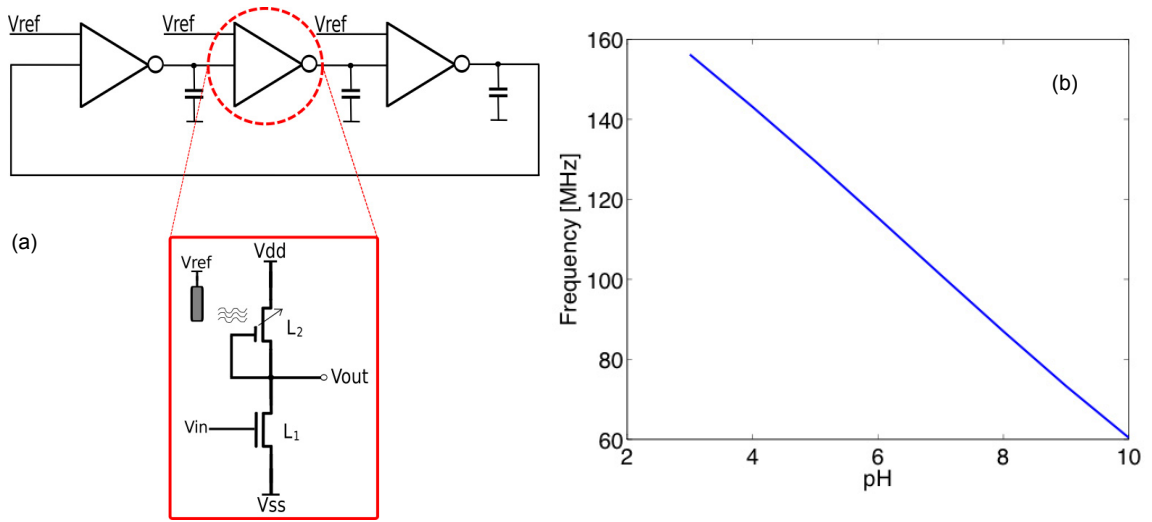

Fig. 2. (a) Ring oscillator schematic. (b) Oscillating frequency of the ring oscillator versus pH.

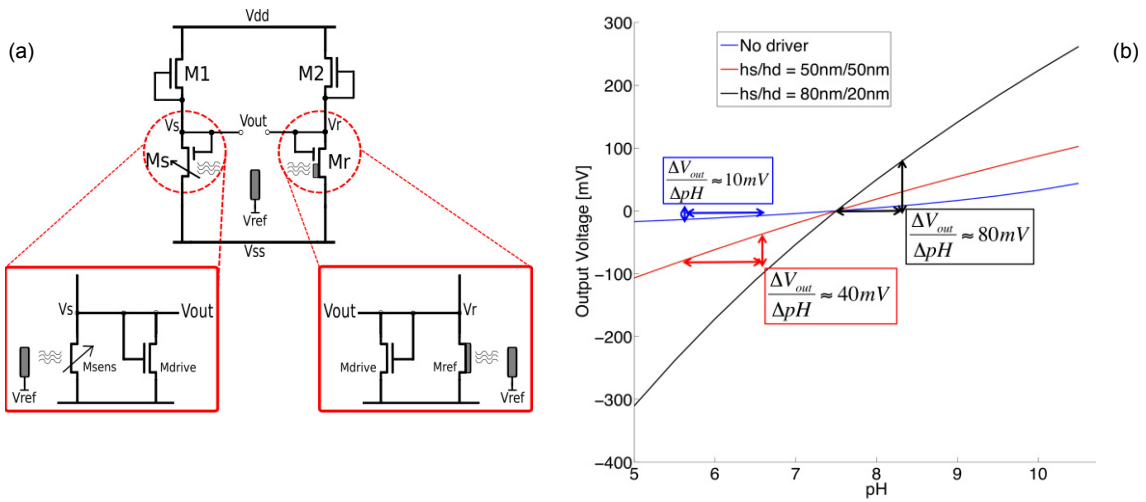

Fig. 3. (a) Schematic of the pseudo-differential amplifier with the equivalent circuit of the hybrid device in the insets. (b) Simulation of the output voltage for different h_s/h_d ratios (compared to the output with no driving transistors).

3. Pseudo-differential amplifier

Fig. 3a shows the second proposed circuit: A pseudo-differential amplifier. Two hybrid FinFETs constitute a pseudo differential pair: One is used for sensing, i.e., its surface is chemically active, and the other one is used as a reference, i.e., its surface is passivated. Two DG-MOSFETs are then used as loads. As an example, the surface of the sensing FinFET could be modified so to be sensitive to a specific protein, while the surface of the reference FinFET would be inert. This way a differential measurement can be carried out, alleviating common variations due to temperature or solution drifts.

The gate of the driving transistor of the hybrid FinFET can be connected to the output, implementing an amplifier stage as shown in the insets of Fig. 3a, with a gain directly proportional to the square root of h_{sens}/h_{drive} . The simulation results in Fig. 3b show that a gain of 6 dB can be achieved (for the same V_{ref}), just by changing in the design phase the ratio between the sensing part and the driver part in the hybrid FinFET. Other simulations [1] showed that a higher gain can be achieved with higher V_{ref} values and grounded driving transistors at the expenses of reduced linearity.

4. Conclusions

We have proposed DG-FinFETs as biosensing devices, and we have demonstrated two FinFET-based circuits that can simultaneously provide biosensing capabilities and sensor readout: A ring oscillator, whose oscillating frequency linearly depends on the biosensing event, and a pseudo-differential amplifier for differential measurements with an intrinsic gain set by the fin height ratio between the sensing part and the driving part of the FinFET.

This way the sensor is completely integrated into the readout circuitry, and the requirements on the following readout stages can be relaxed.

Acknowledgements

This project is funded by the Swiss federal research initiative Nano-Tera within the “NanowireSensor” project under reference number 611_61.

References

- [1] S. Rigante, P. Livi et al., *Hybrid DG-MOSFETs Integrated Circuits for Enhanced Ionic and Biological Sensing Applications*, Biosensors and Bioelectronics Conference 2012, accepted
- [2] J. Alvarado et al., *Implementation of the symmetric doped double-gate MOSFET model in Verilog-A for circuit simulation*, Int. J. Numer. Model. 2010; 23:88-106