

Available online at [www.sciencedirect.com](http://www.sciencedirect.com)

Biochimica et Biophysica Acta 1719 (2005) 6–23

<http://www.elsevier.com/locate/bba>

Review

## Regulation of connexin expression

Masahito Oyamada <sup>a,\*</sup>, Yumiko Oyamada <sup>a,b</sup>, Tetsuro Takamatsu <sup>a</sup>

<sup>a</sup> Department of Pathology and Cell Regulation, Kyoto Prefectural University of Medicine, Kawaramachi Hirokoji, Kamigyo-ku, Kyoto 602-8566, Japan

<sup>b</sup> Department of Pathology, Meiji University of Oriental Medicine, Kyoto, Japan

Received 11 July 2005; received in revised form 29 October 2005; accepted 2 November 2005

Available online 18 November 2005

### Abstract

Gap junctions contain cell–cell communicating channels that consist of multimeric proteins called connexins and mediate the exchange of low-molecular-weight metabolites and ions between contacting cells. Gap junctional communication has long been hypothesized to play a crucial role in the maintenance of homeostasis, morphogenesis, cell differentiation, and growth control in multicellular organisms. The recent discovery that human genetic disorders are associated with mutations in connexin genes and experimental data on connexin knockout mice have provided direct evidence that gap junctional communication is essential for tissue functions and organ development. Thus far, 21 human genes and 20 mouse genes for connexins have been identified. Each connexin shows tissue- or cell-type-specific expression, and most organs and many cell types express more than one connexin. Cell coupling via gap junctions is dependent on the specific pattern of connexin gene expression. This pattern of gene expression is altered during development and in several pathological conditions resulting in changes of cell coupling. Connexin expression can be regulated at many of the steps in the pathway from DNA to RNA to protein. However, transcriptional control is one of the most important points. In this review, we summarize recent knowledge on transcriptional regulation of connexin genes by describing the structure of connexin genes and transcriptional factors that regulate connexin expression.

© 2005 Elsevier B.V. All rights reserved.

*Keywords:* Connexin; Gap junction; Gene regulation; Alternative splicing; Transcription factor

### Contents

1. Introduction . . . . .	7
2. Gene structure of connexins . . . . .	8
2.1. Cx32 . . . . .	8
2.2. Cx40 . . . . .	9
2.3. Cx43 . . . . .	10
2.4. Cx45 . . . . .	10
2.5. Cx31 . . . . .	11
2.6. Cx30 . . . . .	12
2.7. Cx26 . . . . .	12
2.8. Cx36, Cx39, and Cx57 genes, whose coding regions are interrupted by introns. . . . .	12
3. Transcriptional factors, biological substances, and signal transduction pathways that regulate expression of connexin genes . . . . .	13
3.1. Cell type-independent (ubiquitous) transcription factors, biological substances, and signal transduction pathways that regulate connexin expression . . . . .	13
3.1.1. Sp1 . . . . .	13
3.1.2. Activator protein 1 (AP-1) . . . . .	13

\* Corresponding author. Fax: +81 75 251 5353.

*E-mail address:* [oyamada@koto.kpu-m.ac.jp](mailto:oyamada@koto.kpu-m.ac.jp) (M. Oyamada).

3.1.3.	Cyclic AMP . . . . .	13
3.1.4.	Retinoids . . . . .	14
3.1.5.	Wnt pathway . . . . .	14
3.1.6.	Ras-Raf-MAPK pathway . . . . .	14
3.2.	Cell type-dependent transcription factors and biological substances that regulate connexin expression . . . . .	14
3.2.1.	Nkx2-5 . . . . .	15
3.2.2.	T-box transcription factors (Tbx5, Tbx2, Tbx3) . . . . .	15
3.2.3.	GATA family . . . . .	16
3.2.4.	HNF-1 . . . . .	16
3.2.5.	Mist1 . . . . .	17
3.2.6.	Sox10 and early growth response gene-2 (Egr2/Knox20) . . . . .	17
3.2.7.	Estrogen . . . . .	18
3.2.8.	Thyroid hormone and parathyroid hormone . . . . .	18
3.2.9.	Other transcription regulators of connexin expression . . . . .	18
3.3.	Gene silencing by DNA methylation of the connexin promoters . . . . .	18
4.	Post-transcriptional regulation of connexin expression . . . . .	19
4.1.	Translational control of connexin expression by internal ribosome entry site (IRES) . . . . .	19
4.2.	Translational control of connexin expression by upstream open reading frames (uORFs) . . . . .	20
5.	Perspectives . . . . .	20
	Acknowledgments . . . . .	20
	References . . . . .	20

## 1. Introduction

Gap junctions are specialized cell–cell junctions that directly link the cytoplasm of neighboring cells. They mediate the direct transfer of low-molecular-weight (<1000 Da) metabolites and ions, including second messengers such as cyclic AMP, inositol trisphosphate and  $\text{Ca}^{2+}$ , between adjacent cells. Therefore, it has long been hypothesized that gap junctional intercellular communication plays a crucial role in the maintenance of homeostasis, morphogenesis, cell differentiation, and growth control in multicellular organisms. Recent discoveries of human genetic disorders due to mutations in gap junction protein (connexin [Cx]) genes and experimental data on connexin knockout mice provide direct evidence that gap junctional intercellular communication is essential for tissue functions and organ development, and that its dysfunction causes diseases.

Thus far, 21 human genes and 20 mouse genes for connexins have been identified [1]. Each connexin shows tissue- or cell-type-specific expression, and most organs and many cell types express more than one connexin (Table 1). Some connexins, such as Cx32 and Cx43, are expressed in cells of many types, but others are expressed in very limited organs and cells. Even in the same tissue, the expression pattern of each connexin shows cell-type specificity and developmental changes, suggesting the presence of distinct but tight control mechanisms for regulation of connexin gene expression. For example, in the adult mouse heart tissue [2], Cx43 is expressed in all the cardiac components excluding the sinoatrial (SA) and atrioventricular (AV) nodes, the His bundle, and the proximal parts of the bundle branches (BBs). On the other hand, Cx40 expression is restricted to the atria, the AV node, and the His-Purkinje system. Similarly, Cx45 is restricted to the SA and AV nodes, around the His-Purkinje system, and the most peripheral regions of the interventricular septum. These cardiac connexins have different patterns of expression during development; e.g., the pattern of Cx43

expression is the inverse of the Cx40 expression pattern. Other examples for cell-type-specific patterns of connexin expression, connexin expression in the skin and central nervous system, are shown in Table 2 [3,4] and Table 3. Transgenic approaches with mice carrying an appropriate reporter gene (LacZ, placental alkaline phosphatase, enhanced green fluorescent protein) instead of the connexin coding region not only confirmed data obtained from immunocytochemistry but also showed the expression of connexins, which would otherwise have remained undiscovered [5–8]. Studies using connexin-deficient mice also have provided evidence as to which connexin is functional in a certain cell type [5–9]. For recent reviews on gap junctions in the nervous system, see references [10–12].

There is growing evidence that a single gap junction channel can be made of different connexins, i.e., two connexons each consisting of different types of connexins can form a heterotypic gap junction channel, whereas one connexon containing different types of connexins can form a heteromeric gap junction channel. Distinct electrophysiological and ion-selective properties have been shown not only for homotypic gap junction channels made of different connexins but also between homotypic and heterotypic gap junction channels. The regulation of expression of each connexin can influence the function of not only homotypic and heterotypic gap junctions but also heteromeric gap junctions.

Cell coupling via gap junctions is dependent on the specific pattern of connexin gene expression. This pattern of gene expression is altered during development and in several pathological conditions resulting in changes of cell coupling. Like other genes, connexin expression can be regulated at many of the steps in the pathway from DNA to RNA to protein, i.e., transcriptional control, RNA processing control, RNA transport and localization control, translational control, mRNA degradation control, and protein activity control. Among these six steps, however, transcriptional control is the most important

Table 1  
Connexin genes and their expression

Human		Chromosomal locus	Mouse	Major expressed organ or cell types
Name	HUGO (Greek letter) nomenclature		Name	
Molecular mass nomenclature	HUGO (Greek letter) nomenclature		Molecular mass nomenclature	
hCx23	–	?	mCx23	–
hCx25	–	6	–	–
hCx26 <sup>a</sup>	GJB2	13q11–q12	mCx26 <sup>a</sup>	Breast, cochlea, placenta, hepatocytes, skin, pancreas, kidney, intestine
hCx30	GJB6	13q12	mCx30	Brain, cochlea, skin
hCx30.2	GJE1	7q22.1	mCx29	Brain, spinal cord, Schwann cells
hCx30.3	GJB4	1p35–p34	mCx30.3	Skin, kidney
hCx31	GJB3	1p34	mCx31	Cochlea, placenta, skin
hCx31.1	GJB5	1p35.1	mCx31.1	Skin
hCx31.9	GJC1 (GJA11)	17q21.1	mCx30.2	–
hCx32	GJB1	Xq13.1	mCx32	Hepatocytes, secretory acinar cells, Schwann cells
–	–	–	mCx33	Sertoli cells
hCx36	GJA9	15q13.2	mCx36	Neurons, pancreatic $\beta$ -cells
hCx37	GJA4	1p35.1	mCx37	Endothelium, granulosa cells, lung, skin
hCx40	GJA5	1q21.1	mCx40	Cardiac conduction system, endothelium, lung
hCx40.1	–	–	mCx39	–
hCx43	GJA1	6q21–q23.2	mCx43	Many cell types
hCx45	GJA7	17q21.31	mCx45	Cardiac conduction system, smooth muscle cells, neurons
hCx46	GJA3	13q11–q12	mCx46	Lens
hCx47	GJA12	1q41–q42	mCx47	Brain, spinal cord
hCx50	GJA8	1q21.1	mCx50	Lens
hCx59	GJA10	1p34	–	–
hCx62	–	6q15–q16	mCx57	Retinal horizontal cells

<sup>a</sup> Orthologous genes of human and mouse connexin genes are listed in the same line.

[13–15]. In this review, we summarize recent knowledge on transcriptional regulation of connexin genes by describing the structure of connexin genes, and transcriptional factors and biological substances that regulate connexin expression.

## 2. Gene structure of connexins

Early studies seemed to show that the general genomic structure of connexin genes is rather simple, i.e., a 5'-untranslated region (5'-UTR) on exon 1 is separated from the complete connexin coding region and the subsequent 3'-untranslated region (3'-UTR), both located on exon 2. However,

recent data on genomic organization of several connexin genes refutes this simplicity. First, many different splice isoforms of several connexin genes have recently been identified, indicating that different 5'-UTRs can be spliced in a consecutive and/or alternate manner possibly due to alternate promoter usage. However, it should be emphasized that these transcript isoforms vary only in their untranslated, mostly 5'-UTRs that leave their coding regions unaltered. Second, the coding region can be interrupted by introns, e.g., Cx36, Cx39, and Cx57 genes [1]. We will discuss the gene structure of several connexin genes in some detail in the following sections.

### 2.1. Cx32

Miller et al. [16] first reported the structure of the rat Cx32 gene and showed that the 5'-UTR of the transcript in the liver

Table 2  
The expression of connexins in skin

	Human	Rodent
Epidermis		
Basal cell layer	Cx26; (Cx43)	Cx43; Cx40; Cx37; (Cx31)
Spinous cell layer	Cx43>Cx31>Cx37	Cx43; Cx37; Cx31.1; Cx31; Cx30.3
Granular cell layer	Cx43>Cx31>Cx37	Cx37; Cx31.1; Cx31; Cx30.3; (Cx30; Cx26)
Hair follicle		
Internal root sheath	Cx26>Cx43	Cx31; Cx26
Outer root sheath	Cx43>Cx26	Cx43>Cx40
Sebaceous glands	Cx43	Cx31>Cx40/Cx43
Eccrine sweat glands	Cx31; Cx26; (Cx43)	Cx31; Cx26
Dermal fibroblasts	Cx43; Cx40	Cx43

Human data from [3] and rodent data from [3] and [4]. Connexins in parentheses were found in small amounts.

Table 3  
The expression of connexins in the central nervous system

	Expressed connexins	Functional connexins demonstrated by targeted ablation in mice
Neurons	Cx36, Cx45, Cx57	Cx36 [9], Cx45 [8], Cx57 [6]
Astrocytes	Cx30, Cx43, Cx26	Cx30, Cx43
Oligodendrocytes	Cx29, Cx32, Cx47	Cx47 [5]
Leptomeningeal cells	Cx26, Cx30, Cx43	
Ependymal cells	Cx30, Cx43	
Microglia	Cx36, Cx43	

Data for expressed connexins are based on [10–12].

contains a 6.1-kb intron and that transcription starts at non-coding exon (in this review, the nomenclature used for an exon localized at most 5' regions is exon 1) upstream of the intron, while the complete coding sequence is not interrupted by an intron but contained within one exon (in this review, the nomenclature used for this exon is exon 2). It is now known that multiple alternatively spliced transcripts of Cx32 gene exist in mammalian species, i.e., two different transcripts in the rat [17,18] and human [19], and three different transcripts in the cow [20] and mouse [21]. It can be generalized that in the hepatocyte and secretory acinar cell, Cx32 mRNA is made from the promoter 1 (P1) upstream of exon 1 and in Schwann cells from an alternative promoter 2 (P2) upstream of exon 1B that is located upstream of the coding exon (exon 2). Therefore, promoter P2 is called nerve-specific promoter (in this review, the nomenclature used for an exon downstream of the nerve-specific promoter of Cx32 gene is exon 1B). In cattle and mice, exon 1A is localized between exon 1 and exon 1B (Fig. 1).

Human Cx32 gene consists of three exons (1, 1B, and 2) that are alternatively spliced to produce mRNAs with different 5'-UTR [19]. Transcription is initiated from two tissue-specific promoters. In liver and pancreas, promoter P1, located more than 8 kb upstream of the translation start codon, is used, and the transcript is processed to remove a large intron. In contrast, in nerve cells, transcription is initiated from promoter P2, located 497 bp upstream from the translation start codon, and the transcript is processed to remove a small 355-pb intron. The downstream exon 2, which includes the entire coding sequence, is shared by both mRNAs.

Mouse Cx32 gene contains at least four exons, 1, 1A, 1B, and 2 [21]. Exon 1 is mapped about 6.5 kb upstream of exon 2, which harbors the entire coding region. Exon 1A is localized approximately 2 kb upstream of exon 2. Exon 1B is located 310 bp upstream of exon 2. Three transcripts (E1/E2, E1A/E2, E1B/E2) have been identified. Transcript E1/E2 is transcribed in the hepatocyte using the promoter P1 upstream of exon 1, whereas transcript E1B/E2 is transcribed in the Schwann cell using promoter P2 upstream of exon 2. Transcript E1A/E2 is transcribed in embryonic cells, oocytes, and liver. Bovine Cx32 gene also has at least four exons [20].

Rat Cx32 gene contains at least three exons, 1, 1B, and 2 [17]. Two transcripts (E1/E2, E1B/E2) have been identified. The upstream promoter P1 that directs the synthesis of transcript E1/E2 is active in epithelial cells (liver, pancreas), whereas the downstream promoter P2 that directs transcript E1B/E2 is active in peripheral nerves.

The promoter P1 contains putative binding sites not only for cell type-independent (ubiquitous) transcription factors, such as binding sites for Sp1/Sp3 [22–24], nuclear factor 1 (NF-1) [25], and Yin Yang 1 (YY1) [24], but also for cell-type-dependent transcription factors including hepatocyte nuclear factor-1 (HNF-1) [22,25,26]. The nerve-specific promoter P2 also includes binding sites for cell-type-specific transcription factors such as Sox10 and early growth response gene-2 (Egr2/Knox20) [27,28]. Each transcription factor will be described below.

## 2.2. Cx40

Concerning Cx40 mRNA, two different transcripts are found in the human [29], three different transcripts in the mouse [30], and one transcript in the rat have been found. More importantly, these different transcripts are transcribed in a tissue-specific manner in the human and mouse (Fig. 2).

Human Cx40 gene contains at least three exons, 1A, 1B and 2, which are present in two lineage-specific variants: transcript 1A and transcript 1B are derived from alternative 5' non-coding exons (exon 1A and 1B) [29]. Each of two exons is transcribed independently [transcript 1A (E1A/E2) and transcript 1B (E1B/E2)]. These transcripts are transcribed in a cell-type-specific manner; e.g., human umbilical cord vein endothelial cells (HUVEC) express only transcript 1A, while the human choriocarcinoma cell lines BeWo, JAR, and JEG-3 and purified cytotrophoblasts from first-trimester human placenta express only transcript 1B. In the human heart, however, both transcripts were found to be expressed in various regions, i.e., left atrium, right atrium, left ventricle, and right ventricle. Quantitative real-time RT-PCR analysis showed that transcript 1B is always less abundant than transcript A in these different regions in the heart: for example, transcript 1B was 3- and 28-fold less abundant than transcript 1A in the left atrium and left ventricle. In the case of the human heart, it should be noted that

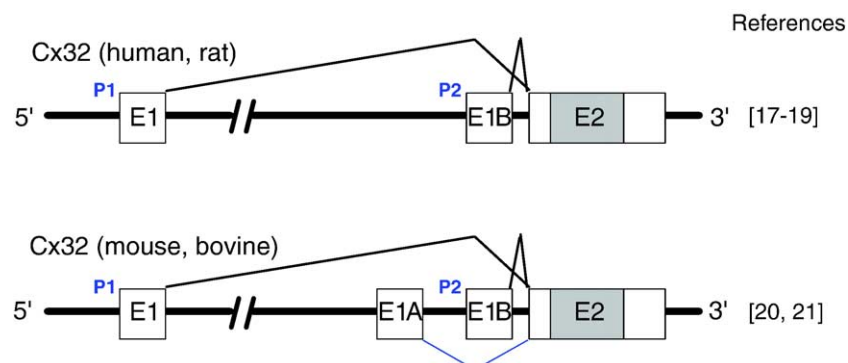

Fig. 1. Structure and splice patterns of the human, rat, mouse, and bovine Cx32 genes. Exon (E) sequences are shown as boxes, whereas the solid grey parts represent coding sequences. Bovine exon 1A is not identical with mouse exon 1A.

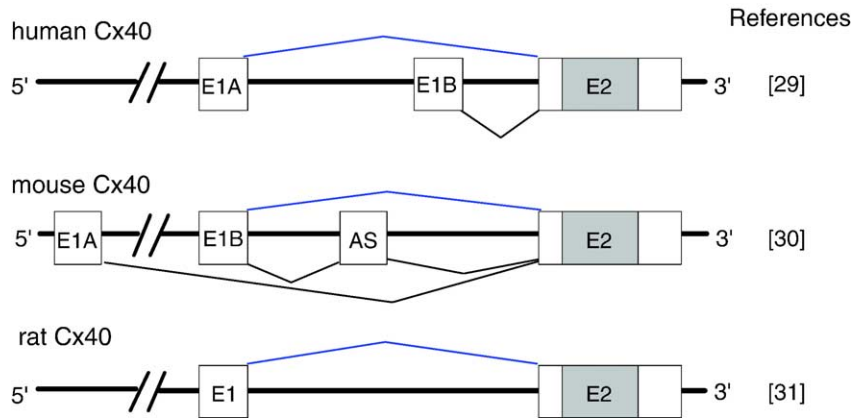

Fig. 2. Structure and splice patterns of the mouse, rat, and human Cx40 genes. Exon (E) sequences are shown as boxes, whereas the solid grey parts represent coding sequences.

each cardiac tissue contains not only cardiomyocytes but also vascular endothelial cells, both of which express Cx40. Therefore, it remains to be elucidated which transcript is expressed in the cardiomyocyte and whether different transcripts are expressed in cardiomyocytes from the various regions.

In the mouse Cx40 gene, three 5'-UTR exons, exon 1A, 1B, and AS, and three transcripts (E1A/E2, E1B/E2, E1B/AS/E2) were very recently identified [30]. A transcript containing exon AS is nearly absent in mouse embryo and heart, but it is especially abundant in the esophagus. On the other hand, transcripts that include exon 1a were reported to be ubiquitous in all the tissues tested.

In the rat, no alternative Cx40 transcripts have so far been reported [31]. Human Cx40 exon 1A is orthologous to the mouse Cx40 exon 1B and rat Cx40 exon 1.

### 2.3. Cx43

Cx43 gene was originally described as consisting of two exons, one containing most of the 5'-UTR and the other containing the protein sequence and 3'-UTR [32–35]. However, Pfeifer et al. [36] reported that in mice there are four additional exons, all of which code for novel 5'-UTRs. They showed that altogether six exons, five of which code for 5'-UTRs (exon 1A–1E), one for the coding region (exon 2), and three alternate promoter regions (P1–P3) are present in the mouse Cx43 gene, and that four of the six exons (exon 1A–1C, exon 2) found in the mouse are also present in the rat. No equivalents of mouse exons 1D or 1E were found in the rat (Fig. 3). In the human, however, no alternate 5'-UTR has been found so far.

Pfeifer et al. [36] also showed that in the mouse, nine different Cx43 mRNAs (transcripts E1As/E2, E1A/E2, E1A<sub>L</sub>/E2, E1A/E1E/E2, E1Bs/E2, E1Bs/E1D/E2, E1B<sub>L</sub>/E2, E1C/E2, E1C/E1D/E2) are generated by differential promoter usages and alternative splicing mechanisms. In rats, six different Cx43 mRNA species (transcripts E1As/E2, E1A/E2, E1A<sub>L</sub>/E2, E1B/E2, E1Cs/E2, E1C<sub>L</sub>/E2) were similarly found. In the mouse Cx43 gene, in addition to the promoter P1, which was previously known to be a Cx43 promoter, two additional

promoters downstream of promoter P1 were found; promoter P2 is located within exon 1A, and promoter P3 is located in the intron just upstream of exon 1C. In the heart, promoter P1 is active throughout the organ. Promoter P2 is active in the atrium and septum but not in the ventricle. Promoter P3 is functional only in ventricles and not in atria and septum. Alternative splicing and exon choice seem to be cell-type specific, because transcripts containing exon 1B preferentially skip exon 1D in the septum, whereas in the atrium exon 1D is included in about half of the transcripts.

Carystinos et al. [37] have proposed that the P2 promoter mediates upregulation of Cx43 expression through the Ras signaling pathway and the putative consensus sequence, AGTTC(A/C)A(T/C)CA, was found in the human, mouse and rat Cx43 gene. They showed that this element is recognized by a protein complex that includes c-Myc and HSP90.

Cx43 is the only connexin for which a pseudogene has been reported so far. A pseudogene of Cx43 that lacks an intron of the Cx43 gene has been identified on human chromosome 5, whereas the Cx43 gene has been assigned to human chromosome 6 [38]. Kandouz et al. [39] identified the presence of a pseudogene Cx43 mRNA transcript in several cancer cell lines and in none of the normal mammary epithelial cells studied. They showed that Cx43 pseudogene can be translated in an in vitro translation system, and that the Cx43 pseudogene product inhibits cell growth without affecting gap-junctional intercellular communication.

### 2.4. Cx45

The mouse Cx45 gene is composed of five exons (exons 1A, 1B, 1C, 2, and 3), two of which (exons 1A and 1B) were only very recently reported [30]. Exons 1A, 1B, 1C, and 2 contain only 5' untranslated sequences, and exon 3 contains the remaining 5'-UTR, entire coding sequence and 3'-UTR. Each of exon 1A, 1B, and 1C is spliced to exon 2 and exon 3. A transcript that directly starts at exon 2 is also present [30,40]. Thus, various transcripts (E1A/E2/E3, E1B/E2/E3, E1C/E2/E3, E2/E3) are generated. Transcription of Cx45 from each alternative promoter is tissue-specific, i.e., although transcripts

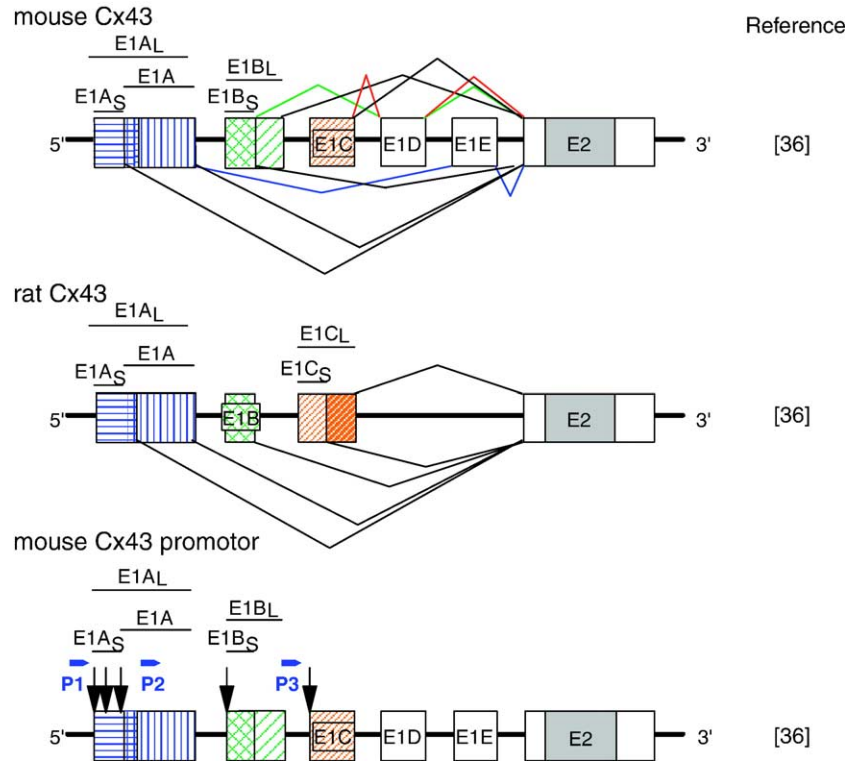

Fig. 3. Structure and splice patterns of the mouse Cx43 (A) and rat Cx43 (B) genes, and promoters of the mouse Cx43 gene (C). Exon (E) sequences are shown as boxes, whereas the solid grey parts represent coding sequences. (A, B) Exon 1A<sub>S</sub> and exon 1A partially overlap. (C) The positions of the transcription start sites are indicated by arrows. The locations of the P1, P2, and P3 promoters are shown by arrowheads. Reproduced from [36] with permission.

containing exon 1A is nearly ubiquitous, exon 1B was found in trace amounts in colon RNA and exon 1C was found colon, bladder, lung, skeletal muscle, ovary, heart, and E14.5 embryo total RNA. Multiple upstream ORF are found in exon 1A and exon 1C [30,40] (Fig. 4A).

Teunissen et al. [15] performed comparative analysis of the Cx45 gene between human and mice, and revealed conservation of E2 and E3 sequence between the two species.

Baldrige et al. [41] found a potential TATA box and two putative AP-1 binding sites in the 5' region of the mouse Cx45 gene, but no functional analysis of the regulatory region of Cx45 has yet been performed.

### 2.5. Cx31

Three exons (exons 1A, 1B, and 2) have so far been identified in the mouse Cx31 gene. The two exons that comprise the 5'-UTR, exons 1A and 1B, lie ~3.7 kb and 2.3 kb upstream of exon 2 (coding exon), respectively [30,42]. Anderson et al. [30] very recently described exon 1A, a novel exon, which appears to be transcribed from previously unknown promoters. They showed that transcripts that include exon 1A are widely distributed in adult tissues, including the skin, but are absent from the brain, and that multiple transcription start sites are present in exon 1A (Fig. 4B).

Mouse exon 1B was cloned and described by Henneman et al. [43]. A proximal promoter region extending to 561 bp upstream of mouse exon 1B serves as a basal promoter in both

mouse embryonic stem (ES) cells and a mouse keratinocyte-derived cell line. The rat exon 1 shows high homology (93%) with mouse exon 1B [42]. Two transcription start sites are identified in exon 1 in the rat. However, in the human Cx31 gene, only the second exon, which contains complete coding region and a part of intron, has been characterized [44].

Both mouse Cx31 exon 1B and rat Cx31 exon 1 are preceded by a TATA-less promoter region. No GC boxes (which may control transcriptional initiation in TATA-less promoters) via binding to the ubiquitous transcription factor Sp1 were found in the (basal) promoter region [42,45]. In rat Cx31 promoter region (935 bp upstream of the 5' flanking region of exon 1), five putative GATA-2/ GATA-3 binding sites, and putative binding sites for NFκB, CCAAT-box, cEBPα/CEBβ, c-AMP-responsive element, and multiple E-box/E-box are found. Despite the presence of multiple binding sites for GATA factors in the putative promoter region of rat Cx31 gene, cotransfection experiments with GATA-3 expression had no influence on the promoter activity of Cx31. At further upstream of basal promoter region (between -3000 and -2200 bp upstream), positive cell-specific regulatory element is found in the rat Cx31 gene [42].

In the mouse, expression of Cx31 in keratinocytes and ES cells is regulated by different cis-regulatory elements and differs in its requirements for the intron *in situ* [45]. A region between 561 and 841 bp upstream of mouse Cx31 exon 1B is essential and sufficient for substantial transcription of Cx31 in mouse keratinocyte-derived Hel37 cells, whereas an intron

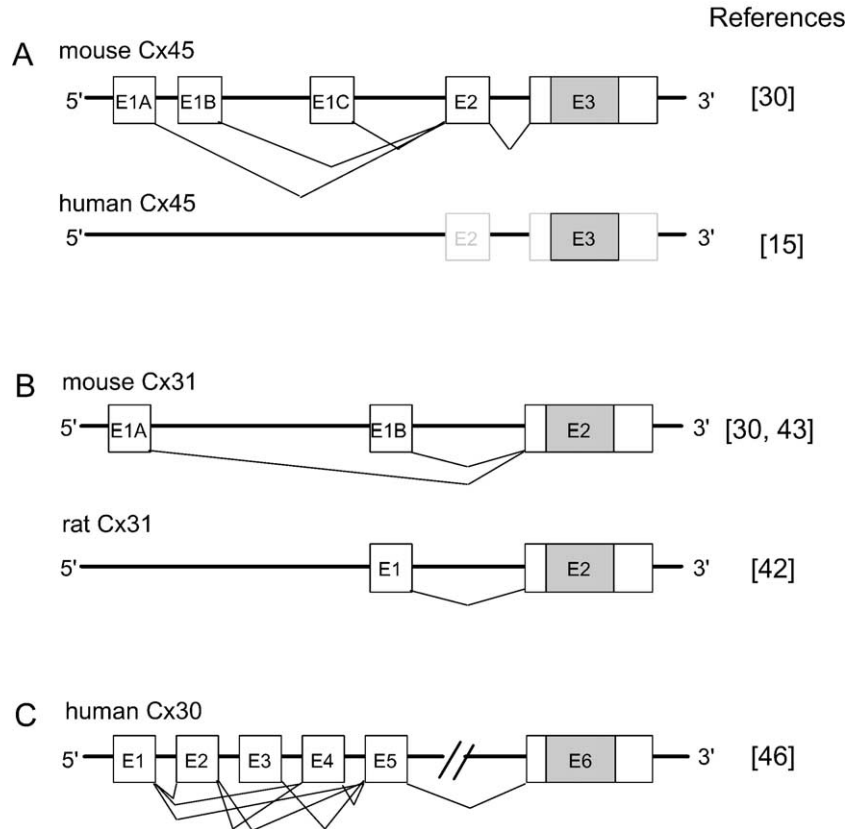

Fig. 4. Structure and splice patterns of the mouse and human Cx45 genes (A), mouse and rat Cx31 genes (B), human Cx30 gene (C). Exon (E) sequences are shown as boxes, whereas the solid grey parts represent coding sequences.

between exon 1B and exon 2 enhances expression of Cx31 in ES cells but not in keratinocyte-derived cells. Splicing is shown to be required for intron-dependent expression enhancement of Cx31 in ES cells because mutations in the splice donor site that prevent transcript processing cause decreased expression of Cx31. The enhancing effect of the intron of the rat Cx31 gene was also found in the mouse keratinocyte line Hel37 as well as in the choriocarcinoma cell line Rcho-1 [42].

## 2.6. Cx30

Essenfelder et al. [46] reported that six different exons are present in the human Cx30 gene. They showed that exon 1 to exon 5 are non-coding exons while exon 6 is a coding exon, and that some of the Cx30 exons can be alternatively spliced, so that the 5' non-coding region of Cx30 transcripts is highly variable. They found that in hair follicle keratinocytes, at least four different splicing variants are present and only exon 5 is present in all transcripts, whereas exon 3, which has been described in human brain cDNA, is absent from Cx30 transcripts from epidermis. Their data suggest that in epidermis, Cx30 transcription starts at exon 1, whereas in cells from the nervous system transcription would start from exon 3 (Fig. 4C).

In the promoter region of the human Cx30 gene, upstream of exon 1, a TATA motif (TTAAAA), several potential binding

sites for Sp1, and consensus sequence (CGCCCCGC) for the early growth response gene product (Egr)-binding are present [46].

The usage of alternative promoters to produce different 5'-UTR of connexin mRNAs has also been reported on mouse Cx46 and Cx47 [30].

## 2.7. Cx26

In contrast to other connexin genes described above, thus far, only two exons, i.e., non-coding exon 1 and exon 2 containing complete connexin coding region and the subsequent 3'-UTR, are known to be present in the mammalian Cx26 gene. In the mouse Cx26 gene, the length is 234 bp for exon 1 and 3.8 kb for intron 1 [25]. Similarly, in the human Cx26 gene, the length is 160 bp for exon 1 and 3148 bp for intron 1 [47]. In the promoter P1 upstream of exon 1, several GC boxes for Sp1/Sp3 binding sites and a TTAAAA box are identified in the mouse [25] and human [47,48] Cx26 genes.

## 2.8. Cx36, Cx39, and Cx57 genes, whose coding regions are interrupted by introns

The coding regions of Cx36, Cx39, and Cx57 genes have been shown to be located on two (or more) different exons. The coding region is interrupted by a 1.14-kb intron, which separates the first 71 bp, starting with ATG, from the rest of

the coding region in the rat [49,50] and mouse [50] Cx36 genes. The coding region of the mouse Cx39 is also interrupted by a 1.5-kb intron, which separates exon 1, coding 21 amino acids, and exon 2, coding 343 amino acids [51]. Concerning mouse Cx57 gene, Hombach et al. [6] found that, at least in the retina, these most C-terminal amino acid residues were replaced after splicing with 12 different amino acid residues coded further downstream. As a result, 97.6% (480 amino acids) of the coding region of mouse Cx57 gene is located on exon 2, whereas the residual 2.4% (12 amino acids) is encoded on a third exon, which is separated by an intron of about 4 kb. When connexin genes contain coding regions that are interrupted by introns, these coding regions have to be spliced properly in order to become translated. Otherwise, alternative splicing (which has not, however, been demonstrated yet) would lead to a dramatic modification of the connexin coding region.

### 3. Transcriptional factors, biological substances, and signal transduction pathways that regulate expression of connexin genes

As described above, in most connexin genes, the basal (canonical, proximal) promoter P1 is located within 300 bp upstream of the transcription initiation site in exon 1. Within the region, binding sites for cell type-independent (ubiquitous) and -dependent transcription factors have been identified in several connexin genes. For example, the former include binding sites for TATA box-binding protein, Sp1/Sp3, and AP-1. The latter include binding sites for cardiac-specific transcription factors (Nkx2-5, GATA4, Tbx5), and HNF-1. Although a sharp distinction between cell type-independent (ubiquitous) and -dependent transcription factors is sometimes difficult to make, we adopt this classification for the convenience of description.

#### 3.1. Cell type-independent (ubiquitous) transcription factors, biological substances, and signal transduction pathways that regulate connexin expression

##### 3.1.1. Sp1

Sp1 is a ubiquitous transcription factor that has a DNA-binding domain that consists of three zinc fingers and recognizes the GC box. Sp-1 binding sites have been identified in connexin genes, and they appear to be a common important element in the basal transcriptional activity of several connexin genes, such as Cx32 [22–24], Cx40 [29,52–55], Cx43 [56–60], and Cx26 [48,61]. For example, Teunissen et al. [54,57] characterized the proximal promoters P1 of rat Cx40 (–175, +85) and Cx43 (–148, +281) genes, in which, respectively, five and four potential binding sites for Sp-family transcription factors were found. They showed that each of these sites contributes to promoter activities and binds both the transcription factors Sp1 and Sp3. They also demonstrated that both Sp1 and Sp3 activated the rat Cx40 and Cx43 promoters P1, and that random disruption of two of the Sp1/Sp3 binding sites almost completely abolished promoter activity of Cx40 genes.

Concerning Cx32, Bai et al. [23] identified two Sp1 binding sites in a basal promoter P1 localized between –179 bp and –134 bp in the rat Cx32 gene. Piechocki et al. [22] also showed that specific nuclear protein–DNA complexes that bound to Sp1 consensus sites within the rat Cx32 basal promoter element (nt –134 to –33) were formed using nuclear extracts from both MH1C1 rat hepatoma cells that express endogenous Cx32 and WB-F344 rat liver epithelial cells that do not. The basal promoter element of rat Cx32 gene (nt –134 to –33) was 1.4-fold more active in MH1C1 cells than in WB-F344 cells, whereas the entire promoter fragment (nt –754 to –33) was 4-fold more active in MH1C1 cells. These data indicate that Sp1 is necessary for Cx32 promoter P1 basal activity, but that some other transcription factor(s) determines the cell-specific expression of Cx32.

##### 3.1.2. Activator protein 1 (AP-1)

Activator protein 1 (AP-1) is composed of homo- or heterodimers of the Jun, Fos, activating transcription factor (ATF), and musculoaponeurotic fibrosarcoma (MAF) proteins via leucine zipper structure and regulates various responses of cells to stimuli. AP-1 binds to a consensus sequence [TGAC (T/G) TCA] in the promoter and induces transcription of the gene. One or more AP-1-binding sites have been identified in the mouse, rat, and human Cx43 proximal promoters P1 (approximately 150 nucleotides up- and downstream of the transcription initiation site) (the rat Cx43 promoter contains two AP-1-binding sites [57], whereas the mouse and human promoters each have one AP-1-binding site). The importance of AP-1 transcription factors in regulation of Cx43 expression in the onset of labor by allowing for an increase in myometrial muscle cell coupling has been demonstrated [35,59,62]. Mitchell and Lye [63] very recently reported that dimers comprising Fos/Jun proteins conferred greater transcriptional activity than Jun dimers, with the Fra-2/JunB combination conferring the greatest activity, and that expression of Fra-2 increases earlier than other Fos family members and confers the highest transcriptional drive to the Cx43 promoter, suggesting that Fra-2 is a central component in the regulation of Cx43 expression during labor.

##### 3.1.3. Cyclic AMP

It has long been known that cyclic AMP (cAMP) enhances gap junction formation and gap-junctional intercellular communication in many cell types. Concerning gap junctions made by Cx43, it is now understood that such enhancement by cAMP is achieved via at least two different mechanisms: initial rapid redistribution of Cx43 to the cell membrane, and later stimulation of Cx43 gene expression. Putative cAMP-responsive element had been identified in the rat Cx43 proximal promoter over a decade ago [34]. Civitelli et al. [64] demonstrated that when rat Cx43 promoter P1 [including 1,339 bases 5' from the transcriptional start site (+1) and 222 bases 3']-luciferase transfected rat osteogenic sarcoma cells (UMR 106-01 cells) were treated with 8Br-cAMP for 6 h, the amount of luciferase activity increased to 2 times the basal activity. van der Heyden et al. [65] also showed that



dibutyryl-cAMP treatment enhanced the activity of rat Cx43 promoter P1 (containing exon I and 1250 bp of upstream sequence)-luciferase, and that enhancement of Cx43 promoter activity by cAMP is additional to that by the Wnt pathway, which will be discussed below, indicating that cAMP and Wnt signaling pathways act in parallel on the Cx43 promoter P1. However, to our knowledge, there are no reports showing that the putative cAMP-responsive element in the proximal Cx43 promoter is really needed for enhancement of Cx43 expression by cAMP or that protein complexes bind to the element.

#### 3.1.4. Retinoids

Like cAMP, retinoids have long been known to induce gap-junctional intercellular communication and upregulate Cx43 expression in normal and preneoplastic cells. Rogers et al. [66] showed that after treatment of confluent 10T1/2 cells with the synthetic retinoid tetrahydrotetramethylnaphthalenylpropenyl-benzoic acid (TTNPB) ( $10^{-8}$  M) caused an approximate 10-fold elevation of Cx43 gene transcripts after 72 h. However, the molecular mechanism for upregulated expression of Cx43 remained to be understood. Clairmont et al. [67,68] hypothesized that retinoic acid increased Cx43 expression in F9 teratocarcinoma cells by stabilizing Cx43 transcripts. On the other hand, Vine et al. [56] reported that neither did retinoids require protein synthesis for induction of Cx43 mRNA nor was the 5.0 h half-life of Cx43 mRNA altered. They showed, using two Cx43 promoter-luciferase constructs (pCx2400luc, which contains the region of the human Cx43 promoter between  $-2200$  bp and  $+209$  bp of the transcriptional start site, and pCx350luc, a smaller fragment of the human Cx43 promoter P1 containing a region between  $-158$  and  $+209$  bp of the transcription start site), that TTNPB treatment resulted in upregulated activity of both of the Cx43 promoter constructs. They found the responsive region within  $-158$  bp and  $+209$  bp of the transcription start site; this contains a Sp1/Sp3 GC-box to which Sp1 and Sp3 are bound, as revealed by electrophoretic mobility shift assays (EMSA), but no retinoic acid response element (RARE), and showed that site directed mutagenesis of a GC-box in this region increased basal levels of transcription and loss of retinoid responsiveness. These results indicate that retinoids transcriptionally activate Cx43 expression.

#### 3.1.5. Wnt pathway

Wnt genes encode a large family of secreted glycoproteins which play important roles in directing cell fate and cell behavior, not only during embryonic development and in adult life, but also in tumorigenesis [69]. Wnt proteins are thought to act via the Frizzled class of cell-surface proteins. Receptor activation leads to inhibition of glycogen synthase kinase 3 $\beta$  (GSK3 $\beta$ ), resulting in stabilization and accumulation of nonphosphorylated  $\beta$ -catenin within the cytosolic compartment. Increased abundance of this pool is associated with entry of  $\beta$ -catenin into the nucleus, where members of the T cell factor/lymphocyte enhancer binding factor (TCF/LEF) family of transcription factors physically interact with  $\beta$ -catenin. In

the nucleus, before Wnt signaling, TCF/LEF members bind to DNA with sequence specificity in promoter and enhancer regions of target genes, and along with Groucho and C-terminal binding protein (CtBP), often repress gene expression. Nuclearly localized  $\beta$ -catenin/TCF complexes are supposed to activate transcription of target genes by binding to the specific consensus sequence A/TA/TCAAAG, known as the TCF/LEF binding site.

van der Heyden et al. [65] performed a computer search for TCF/LEF regulatory elements in the rat Cx43 promoter P1 and found that this promoter contains two TCF/LEF binding consensus sequences in opposite orientations, i.e., TCF/LEF site 1 is located at  $-1394$  bp while site 2 is located at  $-714$  bp with respect to the transcription start site, and a third consensus sequence is found in the first intron following a non-translated short exon. Two similar TCF/LEF motifs are also found in the human and mouse Cx43 promoters partly at similar positions, and a third one is located in the first intron [35,70].

In fact, several studies have suggested that Cx43 acts as a functional target of Wnt1 signaling. van der Heyden et al. [65] investigated the effects of Wnt1 overexpression on gap-junctional communication in the rat neural-crest-derived cell line PC12. They found that Wnt1-expressing clones display an increased electrical and chemical coupling, which coincides with an increased expression of Cx43 mRNA and protein, whereas other connexins, Cx26, Cx32, Cx37, Cx40, and Cx45, are not upregulated. They also showed in transient transactivation assays in P19 EC cells that Wnt1 and  $\text{Li}^+$ , an ion that mimics Wnt signaling, increased transcription from the rat Cx43 promoter containing exon I and 1250 bp of upstream sequence, potentially via TCF/LEF binding elements. Ai et al. [71] also reported that neonatal rat cardiomyocytes responded to  $\text{Li}^+$  by accumulating the effector protein  $\beta$ -catenin and by inducing Cx43 mRNA and protein markedly, and that by transfecting a Cx43 promoter P1-reporter gene construct into cardiomyocytes, the inductive effect of Wnt signaling was transcriptionally mediated.

#### 3.1.6. Ras-Raf-MAPK pathway

Carystinos et al. [37] found that both Cx43 mRNA and protein levels are increased in H-Ras-overexpressing NIH3T3 cells and that the cells also have enhanced Cx43 promoter P2 activation, which is inhibited by the MEK1 inhibitor. Furthermore, they showed that a 200-bp region downstream of the Cx43 transcription start site is the minimal sequence essential for the Ras-mediated Cx43 upregulation and that a protein complex in nuclear extracts from NIH3T3-Ras and MCF7-Ras selectively recognizes a consensus sequence, AGTTCAATCA, located at positions  $+149$  to  $+158$  of the Cx43 promoter P2, in which complex the 90-kDa heat shock protein (HSP90) and c-Myc are identified as constituents.

### 3.2. Cell type-dependent transcription factors and biological substances that regulate connexin expression

In addition to the maintenance of basal level of connexin transcription by the cell type-independent (ubiquitous) tran-

scription factors such as Sp1 and AP1, it is likely that the tissue-specific expression of different connexin genes depends on additional cell type-specific activators or repressors. Although the molecular mechanisms that regulate cell type-specific transcription of each connexin gene are still poorly understood, recent studies have led to a better understanding of the roles of some cell-type-dependent transcription factors in regulation of connexin expression. For example, the crucial roles of cardiac-specific transcription factors in cardiac connexin (Cx40, Cx43, Cx45) expression in the heart have been confirmed by generation of mutant mice such as mice expressing wild-type and a mutant Nkx2-5, Nkx2-5 homozygous or heterozygous knockout mice, and Tbx5 homozygous or heterozygous knockout mice.

### 3.2.1. *Nkx2-5*

Nkx2-5 is a homeodomain-containing transcription factor critical for cardiac development in species ranging from *Drosophila* to humans [72,73]. Heterozygous mutations of Nkx2-5 in humans cause congenital heart disease [74]. Mutations that affect DNA binding are associated with cardiac conduction defects or heart block. Nkx2-5 mRNA and protein are transiently upregulated during the formation of cardiac conduction system relative to the surrounding myocardium in embryonic chick, mouse, and human hearts, suggesting a role in the development of the conduction system [75].

Potential Nkx2.5-binding sites have been identified in the proximal promoters P1 of mouse/rat Cx40 and rat Cx43 genes. In fact, Linhares et al. [52] demonstrated that Nkx2-5 could interact specifically with the potential binding site present in the minimal promoter region of the mouse Cx40.

From the multiple experimental results obtained for mice expressing wild-type and a mutant Nkx2-5 and for Nkx2-5 homozygous or heterozygous knockout mice, we may conclude that Nkx2-5 can act as an activator as well as repressor of Cx43. Kasahara et al. [76] reported that expression of Cx40 and Cx43 was dramatically decreased in the transgenic heart expressing a DNA binding-impaired mutant of mouse Nkx2-5, suggesting a positive role of Nkx2-5 in Cx40 and Cx43 gene regulation. A subsequent study by Kasahara et al. [77] demonstrated that cardiomyocytes expressing wild-type Nkx2.5 or a putative transcriptionally active mutant (*carboxyl-terminus* deletion mutant) had dramatically reduced expression of Cx43, and that Cx43 was downregulated in wild-type Nkx2.5 adenovirus-infected adult cardiomyocytes as early as 16 h after infection, indicating that Cx43 downregulation is due to Nkx2.5 overexpression but not due to heart failure phenotype *in vivo*. Teunissen et al. [57] also reported that Cx43 protein and mRNA in rat primary neonatal ventricular cardiomyocytes were significantly decreased after infection with adenovirus encoding Nkx2.5, and that the rat Cx43 proximal promoter P1 was downregulated approximately 2-fold upon Nkx2.5 overexpression. These results showed that Nkx2-5 can act as an activator as well as repressor of Cx43.

Jay et al. [78] found that an entire population of Cx40 (–)/Cx45 (+) cells is missing in the atrioventricular node of Nkx2-5 heterozygous knockout mice but that, surprisingly, the

cellular expression of Cx40, the major gap junction isoform of Purkinje fibers and a putative Nkx2-5 target, is unaffected. These data demonstrate that half-normal gene dosage of Nkx2-5 is sufficient for specific expression of Cx40 in the conduction system.

Dupays et al. [79] recently investigated cardiac connexin expression in the cardiovascular systems of wild-type and Nkx2-5-knockout 9.2 days post-conception (dpc) mouse embryos and found that the disruption of the Nkx2-5 gene in the mouse heart results in the loss of Cx43 (due in part to the poor development of the ventricular trabecular network) and downregulation of Cx45 gene expression. These results indicate that Nkx2-5 is involved in the transcriptional regulation of the Cx45 gene expression. Concerning Nkx2-5 haploinsufficiency, they showed that RNA extracts from wild-type and heterozygous mutant embryos expressed the Cx45, -43, and -40 genes, and that there were no marked differences between wild-type and heterozygous mutant embryos, suggesting that half-normal gene dosage of Nkx2-5 is sufficient for expression of Cx45, Cx43, and Cx40 in the hearts of 9.2 dpc mouse embryos.

### 3.2.2. *T-box transcription factors (Tbx5, Tbx2, Tbx3)*

T-box transcription factors containing the T-box, which possesses a helix-loop-helix-type DNA-binding domain, form a large family that play a crucial role in several developmental processes [80–82]. This family constitutes activators (e.g., Tbx5) and repressors (e.g., Tbx2 and Tbx3) of transcription that recognize the same binding element.

Tbx5 is one member of a transcription factor family containing the T-box. Tbx5 has been implicated in vertebrate tissue patterning and differentiation [80]. A role for Tbx5 in cardiac morphogenesis has been implied from studies of Holt–Oram syndrome, a rare autosomal dominant human disease caused by Tbx5 mutations [83–85]. Holt–Oram syndrome patients invariably exhibit upper limb malformations and have high incidences of both congenital heart disease, such as tetralogy of Fallot or hypoplastic left heart syndrome [86–88], and abnormal cardiac electrophysiology (particularly atrioventricular block). Tbx5 has a unique pattern of expression; transcripts are abundant in the posterior regions of the embryonic heart and predominate in the myocardium of the left atria, right atria, left ventricle, inflow tract (IFT), atrioventricular canal (AVC), inner curvature, and the atrial septum. Tbx5 is also expressed in the central conduction system (CCS), comprising the SA node, atrioventricular junction including the AV node, and the interventricular (IV) ring including its derivatives, the retroaortic root branch, right atrioventricular ring bundle, atrioventricular bundle (AVB), and proximal part of the BBs. However, expression of Tbx5 is virtually absent from the right ventricle and outflow tract (OFT) [88–90].

Potential T-box binding sites have been identified in rat and mouse Cx40 promoters. Bruneau et al. [91] found five potential T-box binding sites in 1-kb fragments of mouse and rat Cx40 promoters and showed that Tbx5 binds to at least two of those sites. Linhares et al. [52] also demonstrated binding of Tbx5 to

the putative T-box binding site with the mouse proximal Cx40 promoter (150 bp upstream of the transcription start site).

A crucial role of Tbx5 in regulation of Cx40 expression has been revealed by Tbx5 heterozygous knockout (haploinsufficient) mice, a model of human Holt–Oram syndrome. Bruneau et al. [91] found that Tbx5 haploinsufficiency markedly decreased Cx40 mRNA transcription in the heart, indicating that Cx40 is a Tbx5 target gene and that half-normal gene dosage of Tbx5 is insufficient for expression of Cx40. They also showed that when the mouse Cx40 promoter contained within a 1010-bp fragment joined with reporter luciferase construct was cotransfected with RSV-promoted Tbx5 cDNA into noncardiac cells (CV-1), Cx40 promoter activity increased more than 20-fold, demonstrating that the Cx40 promoter is a direct Tbx5 target. Furthermore, they observed synergistic activation of the mouse Cx40 promoter by Tbx5 and Nkx2–5.

In contrast to Nkx2–5, overexpression of Tbx5 has not been reported to downregulate connexin expression. Using clones of the P19Cl6 embryonal carcinoma cell line stably transfected with Tbx5, Fijnvandraat et al. [92] found a strong positive correlation between the levels of Tbx5 transgene mRNA and of Cx40 mRNA, indicating that Tbx5 does not function as a repressor of connexin expression.

Among the T-box transcription factors, Tbx2 and Tbx3 function as repressors of transcription, including that of Cx40 and Cx43 expression. Christoffels et al. [93] showed that when the putative regulatory sequences of mouse Cx40 (a 1.2-kb mouse Cx40 upstream region from –1196 to +62 relative to the transcription start site) and rat Cx43 (a 1.6-kb rat Cx43 upstream region from –1338 to +281) were coupled to the luciferase reporter gene and transfected to Cos-7 or HEK cells, Cx40 promoter activity and to a lesser extent Cx43 promoter activity were repressed by Tbx2. They also found that at mouse developmental stages (embryonic days 9.5–14.5), expression patterns of Tbx2 and cardiac chamber-specific genes including Cx40 and Cx43 were mutually exclusive in the myocardium. Tbx2 is expressed in the IFT, AVC, inner curvature, and OFT, whereas no Tbx2 expression could be observed in the atrial and ventricular chamber myocardium. On the other hand, Cx40 and Cx43 are expressed in the atrial and ventricular chamber myocardium, but absent in the IFT, AVC, inner curvature, and OFT. These data indicate a role of Tbx2 in the repression of the connexin genes in hearts in vivo.

Hoogaars et al. [90] showed that, similarly to Tbx2, the patterns of Tbx3 and cardiac chamber-specific genes including Cx40 and Cx43 are mutually exclusive throughout all stages of mouse heart development (E9–E17.5). In the formed heart, Tbx3 is expressed in the central conduction system, comprising the SA node, AV node, bundle and proximal BBs, as well as the internodal regions and the atrioventricular region. Expression of Cx40 and Cx43 is specifically absent from the Tbx3 expression domain. However, there are some exceptions: at E15.5, weak Tbx3 expression protrudes further into the proximal BB which by then also expresses Cx40, and at E17.5, when the heart has reached its mature form, the AVB expresses low levels of Cx40, coexpressed with Tbx3. Hoogaars et al. [90] also demonstrated that Tbx3 dose-

dependently represses the activity of mouse Cx40 promoter contained in 1.2-kbp Cx40 upstream regulatory region –1196 to +62 relative to the transcription start site. Interestingly, in the adult myocardium, Cx45 is expressed in all components of the conduction system including the Tbx3-positive central conduction system and the Tbx3-negative peripheral conduction system encompassing the distal part of the BBs plus the peripheral ventricular conduction network (the Purkinje fibers).

To summarize, the cardiac expression of Tbx2 decreases from the early stage of heart development, whereas that of Tbx3 increases. Given that Tbx2 and Tbx3 share structure, repressor function, and DNA recognition domain, combined repressive function of Tbx2 and Tbx3 seems to play crucial roles in regional specific expression of Cx40 and Cx43. On the other hand, expression of Cx45 in the heart seems to be regulated independently of repressive function of Tbx2 and Tbx3.

Apart from regulation of connexin expression in the heart, Chen et al. [94] reported that in osteoblast-like cells, the mouse Cx43 promoter (–479 to 0) contains two Tbx2 binding sites. This binding was dependent on the TCACAC consensus sequence, and transient transfection analysis with a Cx43 promoter-driven *lacZ* reporter construct revealed negative regulation of Cx43 transcription mediated by these two Tbx2 binding sites.

### 3.2.3. GATA family

GATA transcription factors contain a highly conserved DNA binding domain consisting of two zinc fingers of the motif Cys–X2–Cys–X17–Cys–X2–Cys that directs binding to the nucleotide sequence element (A/T)GATA(A/G) [95]. Based on their expression patterns, the GATA proteins have been divided into two subfamilies, GATA-1, -2, and -3 and GATA-4, -5, and -6. GATA-1, -2, and -3 genes are prominently expressed in hematopoietic stem cells, where they regulate differentiation-specific gene expression in T-lymphocytes, erythroid cells, and megakaryocytes. GATA-4, -5, and -6 genes are expressed in various mesoderm- and endoderm-derived tissues such as heart, liver, lung, gonad, and gut, where they play critical roles in regulating tissue-specific gene expression.

Linhares et al. [52] showed that GATA4 can interact specifically with its putative site (–49, –36) in the rat/mouse Cx40 proximal promoter, and that the coexpression of GATA4 induced an approximate 6-fold increase in luciferase activity from –1190/+ 121Cx40Luc. Addition of Nkx2–5 with GATA4 led to a 10-fold increase in activation. The same effect was observed when the minimal promoter –50/+ 121 Cx40Luc construct was used, indicating that this region contains the sites required for activation of Cx40 expression by both Nkx2–5 and GATA4 transcription factors.

### 3.2.4. HNF-1

HNF-1 is a transcription factor whose expression has been positively correlated with the differentiated hepatic phenotype and positively regulates many liver-specific genes, e.g.,  $\alpha$ 1-antitrypsin, albumin, and  $\alpha$ - and  $\beta$ -fibrinogen [96]. Two isoforms, HNF-1 $\alpha$  and HNF-1 $\beta$ , are known; the former is

highly expressed in adult liver, whereas the latter is expressed earlier in development. HNF-1 isomers dimerize in a homomeric or heteromeric manner before binding to DNA, and each combination can have distinct effects on transcriptional control, depending upon the target gene. HNF-1 is also expressed in other tissues such as kidney, gut, and pancreas, where it controls the expression of many genes.

Hennemann et al. [25] first reported that the promoter region of the mouse *Cx32* gene contains two putative binding sites for HNF-1 within 680 bp upstream of the main transcription start site. Piechocki et al. [22] showed that promoter activity of the rat *Cx32* promoter (nt –753 to –33) linked to the luciferase gene was correlated with the binding of HNF-1 to two HNF-1 consensus sites centered at –187 and –736, and that expression of HNF-1 and binding to these elements was only observed with rat hepatoma (MH1C1) cells that express endogenous *Cx32*. Koffler et al. [26] demonstrated that stable transfection of non-*Cx32*-expressing WB-F344 rat liver epithelial cells with HNF-1 $\alpha$  stimulated a transfected *Cx32* promoter element (mp –244 to –33), binding of HNF-1 $\alpha$  to the –187 site, and expression of endogenous *Cx32*, and that *Cx32* expression was also significantly decreased in HNF-1 $\alpha$  (–/–) mice. These data suggest that HNF-1 determines the cell-specific expression of *Cx32* based on the cell-type-independent activation of *Cx32* promoter by ubiquitous transcription factors such as Sp1 as described above.

### 3.2.5. *Mist1*

*Mist1* is one of the members of the basic helix–loop–helix (bHLH) protein family that are instrumental in development of numerous organ systems. Rukstalis et al. [97] found that *Mist1* knockout (KO) pancreatic acini are deficient in gap-junctional intercellular communication, mainly due to the loss of *Cx32* expression, and that *Cx32* mRNA and protein levels are greatly reduced in the *Mist1* KO exocrine pancreas, whereas *Mist1* KO acinar cells continue to express the *Cx26* gene. They also showed that co-transfection of cells with the mouse *Cx32* P1 promoter (–680 to +20)-luciferase reporter plasmid (*Cx32p-Luc*) and an expression plasmid encoding *Mist1* generated a 15- to 20-fold increase in *Cx32p-Luc* expression, whereas no other bHLH transcription factor such as E12, E47, HEB, PTF1-p48, NeuroD, MyoD, and Mash1, could activate expression of the *Cx32p-Luc* gene. The ability of *Mist1* to activate expression of the *Cx32p-Luc* gene was dependent on its DNA binding and dimerization properties. From those results, it is concluded that an active *Mist1* protein is required to generate full *Cx32* gene expression in secretory acinar cells.

Concerning tissue-specific *Cx32* expression, combined data on *Mist1* [97] and HNF-1 indicate that there are at least two different activation mechanisms of *Cx32* expression in the epithelial cell: *Mist1*-dependent expression in secretory exocrine cells, including the pancreas, submandibular gland, parotid gland and seminal vesicles and HNF-1-dependent expression in the hepatocyte. Rukstalis et al. [97] described that *Cx32* and *Mist1* co-expression is observed in all secretory exocrine cells, including the pancreas, submandibular gland, parotid gland and seminal vesicles, whereas hepatocytes

express *Cx32* but not *Mist1*. Furthermore, they showed that in the liver tissue of *Mist1* KO mice, expression of *Cx32* transcripts and formation of *Cx32*-containing gap junction plaques remained unchanged, indicating that *Cx32* expression in the liver is independent of *Mist1*. On the other hand, Koffler et al. [26] reported that *Cx32* mRNA content in HNF-1 $\alpha$  homozygous KO mouse liver was approximately one third that of HNF-1 $\alpha$  heterozygous KO mice, suggesting a crucial effect of HNF-1 on *Cx32* in the hepatocyte.

### 3.2.6. *Sox10* and early growth response gene-2 (*Egr2/Knox20*)

The Sox proteins belong to the high mobility group (HMG) box superfamily of DNA-binding proteins. Among them, *Sox10* is first expressed widely in cells of the neural crest at the time of their emergence, and later in neural crest cells that contribute to the melanocyte lineage and to the forming peripheral nervous system. Its expression is detected in the enteric, sensory, and sympathetic ganglia as well as along nerves in a manner typical for the Schwann cell lineage [98].

The early growth response gene-2 (*Egr2/Knox20*) gene was originally identified as a serum response immediate-early gene that encodes a protein with three tandem zinc fingers of cys(2)–his(2) class [99–101]. *Egr2/Knox20* knockout mice showed disrupted hindbrain segmentation and development and a block of Schwann cells at an early stage of differentiation [102,103].

Mutations in *Sox10* genes are discovered in patients with various hereditary neurological diseases including Waardenburg–Hirschsprung disease or Shah–Waardenburg syndrome (WS4), and WS4 with peripheral neuropathy consistent with Charcot–Marie–Tooth disease type I [98]. Mutations in *Egr2/Knox20* gene are identified in patients with congenital hypomyelinating neuropathy and a family with Charcot–Marie–Tooth disease type 1D (CMT1) [103].

Bondurand et al. [27] showed that *Sox10*, in synergy with *Egr2/Knox20*, strongly activates expression of *Cx32*, a major protein of peripheral myelin, in vitro by directly binding to its nerve-specific promoter P2, and that *Sox10* and *Egr2* mutants identified in patients with peripheral myelin defects failed to transactivate the *Cx32* promoter P2. They also demonstrated that a T-to-G point mutation at position –528 of the *Cx32* promoter P2 identified in some CMTX1 patients eliminates binding and activation by *Sox10*. Similarly, Houlden et al. [28] identified a large family with Charcot–Marie–Tooth disease with a G-to-C point mutation at position –526 bp of the *Cx32* promoter P2 and showed that this mutation reduced the activity of the *Cx32* promoter and the affinity for *Sox10* binding. These data suggest that interaction between the *Cx32* P2 promoter, *Sox10*, and *Egr2* plays an important role in *Cx32* expression in the Schwann cell.

In addition to *Cx32*, Jungbluth et al. [104] reported that segment-specific expression of *Cx31* in the mouse embryonic hindbrain is positively regulated by *Egr2/Knox20*. They found that the spatiotemporal patterns of *Cx31* expression in rhombomeres 3 and 5 and in the boundary cap cells are very similar to the expression pattern of *Egr2/Knox20*, and that in *Egr2/Knox20* KO embryos, no *Cx31* expression was detectable

in the developing hindbrain, whereas expression of Cx31 in other sites nonoverlapping with that of Egr2/Krox20, such as in the posterior end of the embryonic body axis, were not affected in Egr2/Krox20 KO embryos.

### 3.2.7. Estrogen

Cx43 expressed in the uterus is thought to play a critical role in the onset of labor by allowing for an increase in myometrial cell coupling and coordinated synchronous contraction of the muscle at the end of pregnancy. Before the onset of labor, there is a dramatic increase in both mRNA and protein levels of Cx43 in the myometrium [105,106]. The Cx43 gene in the myometrium is under the control of steroid hormones, being upregulated by estrogen and downregulated by progesterone [107]. Yu et al. [34] showed that the rat Cx43 promoter contains several sequences resembling half the palindromic estrogen response elements (half-EREs); depending on the concentration of estrogen, the half-EREs were functional when cotransfected with estrogen receptor cDNA into HeLa cells.

However, Oltra et al. [108] described that these half-EREs are not required for the induction of the Cx43 gene; a promoter containing only 145 nucleotides and lacking all half-EREs was shown to be sufficient to achieve full estrogen response. It has also been reported that elevated Cx43 expression in term human myometrium is independent of myometrial estrogen receptors [59]. On the other hand, it has been shown that the expression of several AP-1 family transcription factors (*c-jun* and *c-fos* family of transcription activators) is dramatically increased in the myometrium before the onset of labor and that this expression is regulated by both mechanical and hormonal stimuli [35,59,62]. Therefore, AP-1 proteins play crucial roles in positive regulation of Cx43 expression in the pregnant myometrium as described above.

Besides AP-1 proteins, Oltra et al. [108] reported that Ini, a small nuclear zinc-finger protein, actively participates in the positive response of Cx43 expression to estrogen. They showed that Ini binds to the rat proximal Cx43 promoter between –71 and –34, its expression is ubiquitous, and in the uterus is upregulated by estrogen. Furthermore, transient transfection experiments performed with estrogen receptor alpha cDNA show that overexpression of Ini enhances, in a dose-dependent fashion, the upregulation of the Cx43 gene by estrogen.

### 3.2.8. Thyroid hormone and parathyroid hormone

Stock and Sies [109] demonstrated that after treatment with thyroid hormone Cx43 mRNA was elevated 2.1-fold in rat liver samples as compared to controls, while there was no change in the heart. They identified thyroid hormone response elements in the rat Cx43 promoter region at positions –480 to –464 and showed that the Cx-480 element formed stronger complexes with thyroid hormone receptor alpha/retinoid X receptor alpha heterodimers than with vitamin D receptor/retinoid X receptor alpha heterodimers. In transfected Cos-7 cells, promoter activation via this element was observed after treatment with 3,3',5-triiodo-L-thyronine.

Mitchell et al. [110] showed that in the rat osteosarcoma cell line, parathyroid hormone (PTH) induced a 4-fold increase in activity of Cx43 promoter containing 1.6 kb 5' of the transcription start site, in which responsive sequence was localized to between –31 and +1 bp. They demonstrated that PTH treatment of transgenic mice containing the 1.6 kb promoter luciferase construct induced increases in luciferase and Cx43 immunoreactivity in bone cells underlying the tibial growth plate. They also found that the full Cx43 3'UTR conferred a 3-fold response to PTH when placed 3' of a CMV-luciferase construct, in which responsive sequence was localized to between 2510 and 3132 of the 3'-UTR. These data indicate that PTH responsive sequences are present in the Cx43 promoter and 3'-UTR, suggesting that transcriptional and posttranscriptional pathways operate to regulate PTH-induced Cx43 expression in osteoblast cells.

### 3.2.9. Other transcription regulators of connexin expression

Martin et al. [111] reported that the transcriptional repressor neuron-restrictive silencer factor (NRSF) controls neuron- and beta-cell-specific expression of Cx36 expression. They identified a putative neuron-restrictive silencer element conserved between rodent and human species in a 2043-bp fragment of the human Cx36 promoter, and showed that NRSF binds the neuron-restrictive silencer element. They also demonstrated that this factor is not expressed in insulin-secreting cells and neurons; viral gene transfer of NRSF in insulin-secreting beta-cell lines induced a marked reduction in Cx36 mRNA; repression of Cx36 expression by NRSF is mediated through the recruitment of histone deacetylase to the promoter of neuronal genes.

Ciliary neurotrophic factor (CNTF) is a member of the IL-6 family that is produced as a nonsecreted cytosolic cytokine by astrocytes within the central nervous system and has its specific receptor, termed ciliary neurotrophic factor receptor alpha (CNTFRalpha), located on neuronal cell membranes. Ozog et al. [112] demonstrated that the heterodimer CNTF-CNTFRalpha significantly increased Cx43 mRNA in normal astrocytes in a Janus tyrosine kinase/signal transducer and activator of transcription (JAK/STAT)-dependent manner, whereas CNTF-CNTFRalpha did not alter Cx30 mRNA levels. In the promoter P1 region of mouse Cx43, they identified three putative CNTF-response elements (binding sites for STAT3 dimers that contain base sequences TTCCN<sub>3–5</sub>AA) and showed that these three elements, located at regions –1510, –1179, and –893, are essential for Cx43-regulated expression by CNTF-CNTFRalpha.

### 3.3. Gene silencing by DNA methylation of the connexin promoters

The downregulation of connexin expression is often observed in tumors and transformed cell lines and is believed to contribute to the loss of proliferating control. Despite intensive studies, neither deletion nor mutation of connexin gene has been found in human tumors.

On the contrary, several studies have shown that epigenetic inactivation through hypermethylation of the promoter region could lead to silencing of connexin expression. Piechocki et al. [113] analyzed methylation states of Cx32 and Cx43 promoters using MH1C1 rat hepatoma cells that express Cx32 but not Cx43 and WB-F344 rat liver epithelial cells that express Cx43 but not Cx32. They found that two *MspI/HpaII* restriction sites in the Cx32 promoter (positions –147 and –847) were methylated in WB-F344 cells, but not in MH1C1 cells, whereas an *MspI/HpaII* restriction site in the Cx43 promoter (position –38) was methylated in MH1C1 cells but not in WB-F344 cells. These results suggest that transcription of Cx32 and Cx43 in hepatic cells is controlled by promoter methylation and by cell-specific transcription factors. Tan et al. [114] performed methylation-sensitive single-stranded conformation analysis and found Cx26 promoter methylation in 11 out of 20 human breast cancer tissues and one of eight breast cancer cell lines. They also showed that the most frequently methylated CpG was position –81 in an Sp1 site known to be important for Cx26 gene expression and that treatment of a breast cancer cell line (MD-MBA-453) that was methylated in the Cx26 promoter and did not express Cx26 with 5-aza-2'-deoxycytidine resulted in the re-expression of Cx26 mRNA. Chen et al. [115] reported that in human non-small cell lung cancers, lack of Cx43 mRNA expression in adjacent normal lung tissue was significantly correlated with micrometastasis into lymph nodes and that a higher frequency of promoter methylation was observed in Cx43 mRNA-negative patients compared with Cx43 mRNA-positive patients. Their data also indicate that promoter methylation may interfere with AP1 binding to the promoter, resulting in lack of Cx43 gene expression. Hirai et al. [116] showed that Cx32 expression is downregulated in a human renal cell carcinoma cell (Caki-2 cell) and that hypermethylation in the promoter region is a mechanism for the Cx32 gene repression. Yano et al. [117] also found that the inactivation of Cx32 through hypermethylation of the promoter regions frequently occurred in non-cancerous regions as well as cancerous regions of kidneys from hemodialysis patients, whereas the hypermethylation of Cx32 occurred only in cancerous regions and not in non-cancerous regions of kidneys from the general patients without hemodialysis.

In contrast to the role of hypermethylation of promoters in downregulation of connexin expression in the cancer cell, Singal et al. [118] found no clear correlation between Cx26 expression and hypermethylation of Cx26 5' regions in an immortalized human mammary epithelial cell line (MCF-10) and breast cancer cell lines (MDA-MB231, MCF-7, BT-20, T47-D) and showed that treatment with 5-Aza-CdR resulted in slight or no induction in Cx26 expression in breast cancer cell lines, concluding that hypermethylation is unlikely to be a major mechanism for Cx26 gene repression in human mammary cancer cell lines. Similarly, using several TE cell lines derived from different human esophageal carcinomas and exhibiting different levels of Cx26 expression, Loncarek et al. [119] found no correlation between the Cx26 expression and the methylation level of the promoter region of the Cx26 gene,

suggesting that methylation was probably not involved as a primary mechanism of Cx26 regulation in human esophageal cancer cell lines.

#### 4. Post-transcriptional regulation of connexin expression

Although regulation at the transcriptional level is expected to be a major determinant in connexin gene expression, other mechanisms clearly may influence the level of expression as well.

##### 4.1. Translational control of connexin expression by internal ribosome entry site (IRES)

Recently, there have been examples of internal ribosome entry site (IRES)-containing cellular mRNAs that are translated in cells under normal physiological conditions in which cap-dependent translation is suppressed, specifically, during mitosis, cell stress and apoptosis, cap-dependent translation is shut down, but translation of some proteins important for these biological processes continues. Because IRESs have been identified in some connexin genes, such as Cx43, Cx32, and Cx26, connexin expression could also be regulated by cap-independent translation. Schiavi et al. [120] found that when 5'-UTR of rat Cx43 was inserted between the two genes of a bicistronic vector and transfected into various cell lines, expression of the second gene was significantly increased, demonstrating that the Cx43 5'-UTR contains a strong IRES. Hudder and Werner [121] discovered an IRES element in the 5'-UTR of the nerve-specific Cx32 mRNA, in which a mutation (a C to T transition at position –458 in relation to the start codon) was found in a family with X-linked Charcot–Marie–Tooth disease (CMTX). Because the mutation did not facilitate translation of the second gene in the bicistronic mRNA system, they suggested that this CMTX mutation abolished function of IRES in the 5'-UTR of the wild-type connexin-32 mRNA, leading to a CMTX phenotype, motor and sensory neuropathy. Lahlou et al. [122] found that the restoration of density inhibition of human pancreatic cancer cells by the antiproliferative somatostatin receptor 2 is due to overexpression of endogenous connexins Cx26 and Cx43 and consequent formation of functional gap junctions, and that connexin expression is enhanced at the level of translation but is not sensitive to the inhibition of cap-dependent translation initiation. Furthermore, they identified a new IRES in the Cx26 mRNA and showed that the activities of Cx26 IRES and Cx43 IRES are enhanced in density-inhibited cells, suggesting that the existence of IRESs in connexin mRNAs permits connexin expression in density-inhibited or differentiated cells, where cap-dependent translation is generally reduced.

However, it should be noted that criteria which had been used in identifying putative IRES elements in cellular mRNAs for Cx43 [120] and Cx32 [121] were criticized in a review by Kozak [123], who argued that the absence of RNA analyses does not justify classifying these sequences as IRESs.

#### 4.2. Translational control of connexin expression by upstream open reading frames (uORFs)

Another type of translational control in eukaryotes is effected by one or more short upstream open reading frames (uORFs) that lie between the 5' end of the mRNA and the beginning of the main ORF. An uORF present on an mRNA molecule generally decreases translation of the downstream gene by trapping a scanning ribosome initiation complex. Meijer et al. [124] found that the *Xenopus laevis* Cx41 mRNA contains three uORFs in the 5'-UTR and analyzed the translation efficiency of constructs containing the Cx41 5'-UTR linked to the green fluorescent protein reporter after injection of transcripts into *Xenopus* embryos. They showed that although the translational efficiency of the wild-type Cx41 5'-UTR was only 2% compared with that of the beta-globin 5'-UTR, mutation of each of the three upstream AUGs (uAUGs) into AAG codons enhanced translation 82-, 9-, and 4-fold compared with the wild-type Cx41 5'-UTR. They concluded that the three uORFs may play an important role in the regulation of Cx41 expression. Pfeifer et al. [36] found that among various mouse Cx43 transcripts, the Cx43 5'-UTRs with higher translation efficiencies lack uAUG, whereas those with lowest translational activities contain uAUGs with adequate Kozak consensus sequences. Anderson et al. [30] reported that a subset of the transcripts for mouse Cx31, Cx45, Cx46, and Cx47 contain uORFs.

### 5. Perspectives

As detailed above, recent works demonstrate that the usage of alternative promoters to produce different 5' untranslated regions of connexin mRNAs is not unique to only a few of the connexin genes but is likely a more common feature. It has also been shown that nearly all of the mRNA variants for each connexin gene are expressed in a tissue-specific manner. In more complex processes, such as developmental and pathological states in vivo, connexin expression could be controlled by multiple different regulatory modules, which consist of multiple promoters, variable 5'-UTRs, and IRES elements in the connexin genes. However, the information on transcription factors that regulate connexin expression presented in this article is confined to that concerning the canonical proximal promoters of connexin genes with some exceptions. Mapping and functional characterization of consensus transcription factor binding sites in the alternative promoters and noncoding exons of connexin genes will surely help us to further understand regulation of connexin gene expression.

### Acknowledgments

This work was supported by grants-in-aid for Scientific Research from the Ministry of Education, Culture, Sports, Science, and Technology, Japan.

We are grateful to Ms. Ramona Ratliff for advice on English usage.

### References

- [1] G. Sohl, K. Willecke, An update on connexin genes and their nomenclature in mouse and man, *Cell Commun. Adhes.* 10 (2003) 173–180.
- [2] D. Gros, L. Dupays, S. Alcolea, S. Meysen, L. Miquerol, M. Theveniau-Ruissy, Genetically modified mice: tools to decode the functions of connexins in the heart—New models for cardiovascular research, *Cardiovasc. Res.* 62 (2004) 299–308.
- [3] G. Richard, Connexins: a connection with the skin, *Exp. Dermatol.* 9 (2000) 77–96.
- [4] M. Kretz, K. Maass, K. Willecke, Expression and function of connexins in the epidermis, analyzed with transgenic mouse mutants, *Eur. J. Cell Biol.* 83 (2004) 647–654.
- [5] B. Odermatt, K. Wellershaus, A. Wallraff, G. Seifert, J. Degen, C. Euwens, B. Fuss, H. Bussow, K. Schilling, C. Steinhauser, K. Willecke, Connexin 47 (Cx47)-deficient mice with enhanced green fluorescent protein reporter gene reveal predominant oligodendrocytic expression of Cx47 and display vacuolized myelin in the CNS, *J. Neurosci.* 23 (2003) 4549–4559.
- [6] S. Hombach, U. Janssen-Bienhold, G. Sohl, T. Schubert, H. Bussow, T. Ott, R. Weiler, K. Willecke, Functional expression of connexin57 in horizontal cells of the mouse retina, *Eur. J. Neurosci.* 19 (2004) 2633–2640.
- [7] J. Degen, C. Meier, R.S. Van Der Giessen, G. Sohl, E. Petrasch-Parwez, S. Urschel, R. Dermietzel, K. Schilling, C.I. De Zeeuw, K. Willecke, Expression pattern of *lacZ* reporter gene representing connexin36 in transgenic mice, *J. Comp. Neurol.* 473 (2004) 511–525.
- [8] S. Maxeiner, K. Dedek, U. Janssen-Bienhold, J. Ammermuller, H. Brune, T. Kirsch, M. Pieper, J. Degen, O. Kruger, K. Willecke, R. Weiler, Deletion of connexin45 in mouse retinal neurons disrupts the rod/cone signaling pathway between AII amacrine and ON cone bipolar cells and leads to impaired visual transmission, *J. Neurosci.* 25 (2005) 566–576.
- [9] C.I. De Zeeuw, E. Chorev, A. Devor, Y. Manor, R.S. Van Der Giessen, M.T. De Jeu, C.C. Hoogenraad, J. Bijman, T.J. Ruigrok, P. French, D. Jaarsma, W.M. Kistler, C. Meier, E. Petrasch-Parwez, R. Dermietzel, G. Sohl, M. Gueldenagel, K. Willecke, Y. Yarom, Deformation of network connectivity in the inferior olive of connexin 36-deficient mice is compensated by morphological and electrophysiological changes at the single neuron level, *J. Neurosci.* 23 (2003) 4700–4711.
- [10] J.I. Nagy, F.E. Dudek, J.E. Rash, Update on connexins and gap junctions in neurons and glia in the mammalian nervous system, *Brain Res. Brain Res. Rev.* 47 (2004) 191–215.
- [11] G. Sohl, B. Odermatt, S. Maxeiner, J. Degen, K. Willecke, New insights into the expression and function of neural connexins with transgenic mouse mutants, *Brain Res. Brain Res. Rev.* 47 (2004) 245–259.
- [12] G. Sohl, S. Maxeiner, K. Willecke, Expression and functions of neuronal gap junctions, *Nat. Rev., Neurosci.* 6 (2005) 191–200.
- [13] E.C. Beyer, K. Willecke, Gap junction genes and their regulation, in: E.L. Hertzberg (Ed.), *Gap Junctions*, JAI Press Inc., Stamford, 2000, pp. 1–30.
- [14] A. De Maio, V.L. Vega, J.E. Contreras, Gap junctions, homeostasis, and injury, *J. Cell Physiol.* 191 (2002) 269–282.
- [15] B.E. Teunissen, M.F. Bierhuizen, Transcriptional control of myocardial connexins, *Cardiovasc. Res.* 62 (2004) 246–255.
- [16] T. Miller, G. Dahl, R. Werner, Structure of a gap junction gene: rat connexin-32, *Biosci. Rep.* 8 (1988) 455–464.
- [17] I.M. Neuhaus, G. Dahl, R. Werner, Use of alternate promoters for tissue-specific expression of the gene coding for connexin32, *Gene* 158 (1995) 257–262.
- [18] G. Sohl, C. Gillen, F. Bosse, M. Gleichmann, H.W. Muller, K. Willecke, A second alternative transcript of the gap junction gene connexin32 is expressed in murine Schwann cells and modulated in injured sciatic nerve, *Eur. J. Cell Biol.* 69 (1996) 267–275.
- [19] I.M. Neuhaus, L. Bone, S. Wang, V. Ionasescu, R. Werner, The human connexin32 gene is transcribed from two tissue-specific promoters, *Biosci. Rep.* 16 (1996) 239–248.

- [20] S. Duga, R. Asselta, L. Del Giacco, M. Malcovati, S. Ronchi, M.L. Tenchini, T. Simonic, A new exon in the 5' untranslated region of the connexin32 gene, *Eur. J. Biochem.* 259 (1999) 188–196.
- [21] G. Sohl, M. Theis, G. Hallas, S. Brambach, E. Dahl, G. Kidder, K. Willecke, A new alternatively spliced transcript of the mouse connexin32 gene is expressed in embryonic stem cells, oocytes, and liver, *Exp. Cell Res.* 266 (2001) 177–186.
- [22] M.P. Piechocki, R.M. Toti, M.J. Fernstrom, R.D. Burk, R.J. Ruch, Liver cell-specific transcriptional regulation of connexin32, *Biochim. Biophys. Acta* 1491 (2000) 107–122.
- [23] S. Bai, D.C. Spray, R.D. Burk, Identification of proximal and distal regulatory elements of the rat connexin32 gene, *Biochim. Biophys. Acta* 1216 (1993) 197–204.
- [24] J.M. Field, L.A. Tate, J.K. Chipman, S.D. Minchin, Identification of functional regulatory regions of the connexin32 gene promoter, *Biochim. Biophys. Acta* 1628 (2003) 22–29.
- [25] H. Hennemann, G. Kozjek, E. Dahl, B. Nicholson, K. Willecke, Molecular cloning of mouse connexins26 and -32: similar genomic organization but distinct promoter sequences of two gap junction genes, *Eur. J. Cell Biol.* 58 (1992) 81–89.
- [26] L.D. Koffler, M.J. Fernstrom, T.E. Akiyama, F.J. Gonzalez, R.J. Ruch, Positive regulation of connexin32 transcription by hepatocyte nuclear factor-1alpha, *Arch. Biochem. Biophys.* 407 (2002) 160–167.
- [27] N. Bondurand, M. Girard, V. Pingault, N. Lemort, O. Dubourg, M. Goossens, Human Connexin 32, a gap junction protein altered in the X-linked form of Charcot-Marie-Tooth disease, is directly regulated by the transcription factor SOX10, *Hum. Mol. Genet.* 10 (2001) 2783–2795.
- [28] H. Houlden, M. Girard, C. Cockerell, D. Ingram, N.W. Wood, M. Goossens, R.W. Walker, M.M. Reilly, Connexin 32 promoter P2 mutations: a mechanism of peripheral nerve dysfunction, *Ann. Neurol.* 56 (2004) 730–734.
- [29] L. Dupays, D. Mazurais, C. Rucker-Martin, T. Calmels, D. Bernot, L. Cronier, A. Malassine, D. Gros, M. Theveniau-Ruissy, Genomic organization and alternative transcripts of the human Connexin40 gene, *Gene* 305 (2003) 79–90.
- [30] C.L. Anderson, M.A. Zundel, R. Werner, Variable promoter usage and alternative splicing in five mouse connexin genes, *Genomics* 85 (2005) 238–244.
- [31] W.A. Groenewegen, T.A. van Veen, H.M. van der Velden, H.J. Jongsma, Genomic organization of the rat connexin40 gene: identical transcription start sites in heart and lung, *Cardiovasc. Res.* 38 (1998) 463–471.
- [32] G.I. Fishman, R.L. Eddy, T.B. Shows, L. Rosenthal, L.A. Leinwand, The human connexin gene family of gap junction proteins: distinct chromosomal locations but similar structures, *Genomics* 10 (1991) 250–256.
- [33] R. Sullivan, C. Ruangvoravat, D. Joo, J. Morgan, B.L. Wang, X.K. Wang, C.W. Lo, Structure, sequence and expression of the mouse Cx43 gene encoding connexin 43, *Gene* 130 (1993) 191–199.
- [34] W. Yu, G. Dahl, R. Werner, The connexin43 gene is responsive to oestrogen, *Proc. Biol. Sci.* 255 (1994) 125–132.
- [35] E. Geimonen, W. Jiang, M. Ali, G.I. Fishman, R.E. Garfield, J. Andersen, Activation of protein kinase C in human uterine smooth muscle induces connexin-43 gene transcription through an AP-1 site in the promoter sequence, *J. Biol. Chem.* 271 (1996) 23667–23674.
- [36] I. Pfeifer, C. Anderson, R. Werner, E. Oltra, Redefining the structure of the mouse connexin43 gene: selective promoter usage and alternative splicing mechanisms yield transcripts with different translational efficiencies, *Nucleic Acids Res.* 32 (2004) 4550–4562.
- [37] G.D. Carystinos, M. Kandouz, M.A. Alaoui-Jamali, G. Batist, Unexpected induction of the human connexin 43 promoter by the ras signaling pathway is mediated by a novel putative promoter sequence, *Mol. Pharmacol.* 63 (2003) 821–831.
- [38] K. Willecke, S. Jungbluth, E. Dahl, H. Hennemann, R. Heynkes, K.H. Grzeschik, Six genes of the human connexin gene family coding for gap junctional proteins are assigned to four different human chromosomes, *Eur. J. Cell Biol.* 53 (1990) 275–280.
- [39] M. Kandouz, A. Bier, G.D. Carystinos, M.A. Alaoui-Jamali, G. Batist, Connexin43 pseudogene is expressed in tumor cells and inhibits growth, *Oncogene* 23 (2004) 4763–4770.
- [40] A. Jacob, E.C. Beyer, Mouse connexin 45: genomic cloning and exon usage, *DNA Cell Biol.* 20 (2001) 11–19.
- [41] D. Baldrige, F. Lecanda, C.S. Shin, J. Stains, R. Civitelli, Sequence and structure of the mouse connexin45 gene, *Biosci. Rep.* 21 (2001) 683–689.
- [42] H.D. Gabriel, B. Strobl, P. Hellmann, R. Buettner, E. Winterhager, Organization and regulation of the rat Cx31 gene. Implication for a crucial role of the intron region, *Eur. J. Biochem.* 268 (2001) 1749–1759.
- [43] H. Hennemann, H.J. Schwarz, K. Willecke, Characterization of gap junction genes expressed in F9 embryonic carcinoma cells: molecular cloning of mouse connexin31 and -45 cDNAs, *Eur. J. Cell Biol.* 57 (1992) 51–58.
- [44] K. Wenzel, D. Manthey, K. Willecke, K.H. Grzeschik, O. Traub, Human gap junction protein connexin31: molecular cloning and expression analysis, *Biochem. Biophys. Res. Commun.* 248 (1998) 910–915.
- [45] A. Plum, G. Hallas, K. Willecke, Expression of the mouse gap junction gene Gjb3 is regulated by distinct mechanisms in embryonic stem cells and keratinocytes, *Genomics* 79 (2002) 24–30.
- [46] G.M. Essenfelder, G. Larderet, G. Waksman, J. Lamartine, Gene structure and promoter analysis of the human GJB6 gene encoding connexin 30, *Gene* 350 (2005) 33–40.
- [47] D.T. Kiang, N. Jin, Z.J. Tu, H.H. Lin, Upstream genomic sequence of the human connexin26 gene, *Gene* 199 (1997) 165–171.
- [48] Z.J. Tu, D.T. Kiang, Mapping and characterization of the basal promoter of the human connexin26 gene, *Biochim. Biophys. Acta* 1443 (1998) 169–181.
- [49] D.F. Condorelli, R. Parenti, F. Spinella, A. Trovato Salinaro, N. Belluardo, V. Cardile, F. Cicirata, Cloning of a new gap junction gene (Cx36) highly expressed in mammalian brain neurons, *Eur. J. Neurosci.* 10 (1998) 1202–1208.
- [50] G. Sohl, J. Degen, B. Teubner, K. Willecke, The murine gap junction gene connexin36 is highly expressed in mouse retina and regulated during brain development, *FEBS Lett.* 428 (1998) 27–31.
- [51] J. von Maltzahn, C. Euwens, K. Willecke, G. Sohl, The novel mouse connexin39 gene is expressed in developing striated muscle fibers, *J. Cell Sci.* 117 (2004) 5381–5392.
- [52] V.L. Linhares, N.A. Almeida, D.C. Menezes, D.A. Elliott, D. Lai, E.C. Beyer, A.C. Campos de Carvalho, M.W. Costa, Transcriptional regulation of the murine Connexin40 promoter by cardiac factors Nkx2-5, GATA4 and Tbx5, *Cardiovasc. Res.* 64 (2004) 402–411.
- [53] K.H. Seul, P.N. Tadros, E.C. Beyer, Mouse connexin40: gene structure and promoter analysis, *Genomics* 46 (1997) 120–126.
- [54] B.E. Teunissen, S.C. van Amersfoort, T. Opthof, H.J. Jongsma, M.F. Bierhuizen, Sp1 and Sp3 activate the rat connexin40 proximal promoter, *Biochem. Biophys. Res. Commun.* 292 (2002) 71–78.
- [55] M.F. Bierhuizen, S.C. van Amersfoort, W.A. Groenewegen, S. Vliex, H.J. Jongsma, Characterization of the rat connexin40 promoter: two Sp1/Sp3 binding sites contribute to transcriptional activation, *Cardiovasc. Res.* 46 (2000) 511–522.
- [56] A.L. Vine, Y.M. Leung, J.S. Bertram, Transcriptional regulation of connexin 43 expression by retinoids and carotenoids: similarities and differences, *Mol. Carcinog.* 43 (2005) 75–85.
- [57] B.E. Teunissen, A.T. Jansen, S.C. van Amersfoort, T.X. O'Brien, H.J. Jongsma, M.F. Bierhuizen, Analysis of the rat connexin 43 proximal promoter in neonatal cardiomyocytes, *Gene* 322 (2003) 123–136.
- [58] C.O. Echetebe, M. Ali, M.G. Izban, L. MacKay, R.E. Garfield, Localization of regulatory protein binding sites in the proximal region of human myometrial connexin 43 gene, *Mol. Hum. Reprod.* 5 (1999) 757–766.
- [59] E. Geimonen, E. Boylston, A. Royek, J. Andersen, Elevated connexin-43 expression in term human myometrium correlates with elevated c-Jun expression and is independent of myometrial estrogen receptors, *J. Clin. Endocrinol. Metab.* 83 (1998) 1177–1185.



- [60] M. Fernandez-Cobo, D. Stewart, D. Drujan, A. De Maio, Promoter activity of the rat connexin 43 gene in NRK cells, *J. Cell Biochem.* 81 (2001) 514–522.
- [61] Z.J. Tu, R. Kollander, D.T. Kiang, Differential up-regulation of gap junction connexin 26 gene in mammary and uterine tissues: the role of Sp transcription factors, *Mol. Endocrinol.* 12 (1998) 1931–1938.
- [62] M. Piersanti, S.J. Lye, Increase in messenger ribonucleic acid encoding the myometrial gap junction protein, connexin-43, requires protein synthesis and is associated with increased expression of the activator protein-1, *c-fos*, *Endocrinology* 136 (1995) 3571–3578.
- [63] J.A. Mitchell, S.J. Lye, Differential activation of the connexin 43 promoter by dimers of activator protein-1 transcription factors in myometrial cells, *Endocrinology* 146 (2005) 2048–2054.
- [64] R. Civitelli, K. Ziambaras, P.M. Warlow, F. Lecanda, T. Nelson, J. Harley, N. Atal, E.C. Beyer, T.H. Steinberg, Regulation of connexin43 expression and function by prostaglandin E2 (PGE2) and parathyroid hormone (PTH) in osteoblastic cells, *J. Cell Biochem.* 68 (1998) 8–21.
- [65] M.A. van der Heyden, M.B. Rook, M.M. Hermans, G. Rijksen, J. Boonstra, L.H. Defize, O.H. Destree, Identification of connexin43 as a functional target for Wnt signalling, *J. Cell Sci.* 111 (Pt. 12) (1998) 1741–1749.
- [66] M. Rogers, J.M. Berestecky, M.Z. Hossain, H.M. Guo, R. Kadle, B.J. Nicholson, J.S. Bertram, Retinoid-enhanced gap junctional communication is achieved by increased levels of connexin 43 mRNA and protein, *Mol. Carcinog.* 3 (1990) 335–343.
- [67] A. Clairmont, H. Sies, Evidence for a posttranscriptional effect of retinoic acid on connexin43 gene expression via the 3'-untranslated region, *FEBS Lett.* 419 (1997) 268–270.
- [68] A. Clairmont, D. Tessmann, H. Sies, Analysis of connexin43 gene expression induced by retinoic acid in F9 teratocarcinoma cells, *FEBS Lett.* 397 (1996) 22–24.
- [69] R. Nusse, Wnt signaling in disease and in development, *Cell Res.* 15 (2005) 28–32.
- [70] Z.Q. Chen, D. Lefebvre, X.H. Bai, A. Reaume, J. Rossant, S.J. Lye, Identification of two regulatory elements within the promoter region of the mouse connexin 43 gene, *J. Biol. Chem.* 270 (1995) 3863–3868.
- [71] Z. Ai, A. Fischer, D.C. Spray, A.M. Brown, G.I. Fishman, Wnt-1 regulation of connexin43 in cardiac myocytes, *J. Clin. Invest.* 105 (2000) 161–171.
- [72] S. Zaffran, M. Frasch, Early signals in cardiac development, *Circ. Res.* 91 (2002) 457–469.
- [73] O.W. Prall, D.A. Elliott, R.P. Harvey, Developmental paradigms in heart disease: insights from tinman, *Ann. Med.* 34 (2002) 148–156.
- [74] J.J. Schott, D.W. Benson, C.T. Basson, W. Pease, G.M. Silberbach, J.P. Moak, B.J. Maron, C.E. Seidman, J.G. Seidman, Congenital heart disease caused by mutations in the transcription factor NKX2-5, *Science* 281 (1998) 108–111.
- [75] B.G. Bruneau, Transcriptional regulation of vertebrate cardiac morphogenesis, *Circ. Res.* 90 (2002) 509–519.
- [76] H. Kasahara, H. Wakimoto, M. Liu, C.T. Maguire, K.L. Converso, T. Shioi, W.Y. Huang, W.J. Manning, D. Paul, J. Lawitts, C.I. Berul, S. Izumo, Progressive atrioventricular conduction defects and heart failure in mice expressing a mutant Csx/Nkx2.5 homeoprotein, *J. Clin. Invest.* 108 (2001) 189–201.
- [77] H. Kasahara, T. Ueyama, H. Wakimoto, M.K. Liu, C.T. Maguire, K.L. Converso, P.M. Kang, W.J. Manning, J. Lawitts, D.L. Paul, C.I. Berul, S. Izumo, Nkx2.5 homeoprotein regulates expression of gap junction protein connexin 43 and sarcomere organization in postnatal cardiomyocytes, *J. Mol. Cell. Cardiol.* 35 (2003) 243–256.
- [78] P.Y. Jay, B.S. Harris, C.T. Maguire, A. Buerger, H. Wakimoto, M. Tanaka, S. Kupersmidt, D.M. Roden, T.M. Schultheiss, T.X. O'Brien, R.G. Gourdie, C.I. Berul, S. Izumo, Nkx2-5 mutation causes anatomic hypoplasia of the cardiac conduction system, *J. Clin. Invest.* 113 (2004) 1130–1137.
- [79] L. Dupays, T. Jarry-Guichard, D. Mazurais, T. Calmels, S. Izumo, D. Gros, M. Theveniau-Ruissy, Dysregulation of connexins and inactivation of NFATc1 in the cardiovascular system of Nkx2-5 null mutants, *J. Mol. Cell. Cardiol.* 38 (2005) 787–798.
- [80] V.E. Papaioannou, L.M. Silver, The T-box gene family, *BioEssays* 20 (1998) 9–19.
- [81] M. Tada, J.C. Smith, T-targets: clues to understanding the functions of T-box proteins, *Dev. Growth Differ.* 43 (2001) 1–11.
- [82] T.F. Plageman Jr., K.E. Yutzey, T-box genes and heart development: putting the “T” in heart, *Dev. Dyn.* 232 (2005) 11–20.
- [83] C.T. Basson, D.R. Bachinsky, R.C. Lin, T. Levi, J.A. Elkins, J. Soultis, D. Grayzel, E. Kroumpouzou, T.A. Traill, J. Leblanc-Straceski, B. Renault, R. Kucherlapati, J.G. Seidman, C.E. Seidman, Mutations in human TBX5 [corrected] cause limb and cardiac malformation in Holt–Oram syndrome, *Nat. Genet.* 15 (1997) 30–35.
- [84] C.T. Basson, T. Huang, R.C. Lin, D.R. Bachinsky, S. Weremowicz, A. Vaglio, R. Bruzzone, R. Quadrelli, M. Lerone, G. Romeo, M. Silengo, A. Pereira, J. Krieger, S.F. Mesquita, M. Kamisago, C.C. Morton, M.E. Pierpont, C.W. Muller, J.G. Seidman, C.E. Seidman, Different TBX5 interactions in heart and limb defined by Holt–Oram syndrome mutations, *Proc. Natl. Acad. Sci. U. S. A.* 96 (1999) 2919–2924.
- [85] Q.Y. Li, R.A. Newbury-Ecob, J.A. Terrett, D.I. Wilson, A.R. Curtis, C.H. Yi, T. Gebuhr, P.J. Bullen, S.C. Robson, T. Strachan, D. Bonnet, S. Lyonnet, I.D. Young, J.A. Raeburn, A.J. Buckler, D.J. Law, J.D. Brook, Holt–Oram syndrome is caused by mutations in TBX5, a member of the Brachyury (T) gene family, *Nat. Genet.* 15 (1997) 21–29.
- [86] C.T. Basson, G.S. Cowley, S.D. Solomon, B. Weissman, A.K. Poznanski, T.A. Traill, J.G. Seidman, C.E. Seidman, The clinical and genetic spectrum of the Holt–Oram syndrome (heart–hand syndrome), *N. Engl. J. Med.* 330 (1994) 885–891.
- [87] R.A. Newbury-Ecob, R. Leanne, J.A. Raeburn, I.D. Young, Holt–Oram syndrome: a clinical genetic study, *J. Med. Genet.* 33 (1996) 300–307.
- [88] B.G. Bruneau, M. Logan, N. Davis, T. Levi, C.J. Tabin, J.G. Seidman, C.E. Seidman, Chamber-specific cardiac expression of Tbx5 and heart defects in Holt–Oram syndrome, *Dev. Biol.* 211 (1999) 100–108.
- [89] P.E. Habets, A.F. Moorman, D.E. Clout, M.A. van Roon, M. Lingbeek, M. van Lohuizen, M. Campione, V.M. Christoffels, Cooperative action of Tbx2 and Nkx2.5 inhibits ANF expression in the atrioventricular canal: implications for cardiac chamber formation, *Genes Dev.* 16 (2002) 1234–1246.
- [90] W.M. Hoogaars, A. Tessari, A.F. Moorman, P.A. de Boer, J. Hagoort, A.T. Soufan, M. Campione, V.M. Christoffels, The transcriptional repressor Tbx3 delineates the developing central conduction system of the heart, *Cardiovasc. Res.* 62 (2004) 489–499.
- [91] B.G. Bruneau, G. Nemer, J.P. Schmitt, F. Charron, L. Robitaille, S. Caron, D.A. Conner, M. Gessler, M. Nemer, C.E. Seidman, J.G. Seidman, A murine model of Holt–Oram syndrome defines roles of the T-box transcription factor Tbx5 in cardiogenesis and disease, *Cell* 106 (2001) 709–721.
- [92] A.C. Fijnvandraat, R.H. Lekanne Deprez, V.M. Christoffels, J.M. Ruijter, A.F. Moorman, TBX5 overexpression stimulates differentiation of chamber myocardium in P19C16 embryonic carcinoma cells, *J. Muscle Res. Cell Motil.* 24 (2003) 211–218.
- [93] V.M. Christoffels, W.M. Hoogaars, A. Tessari, D.E. Clout, A.F. Moorman, M. Campione, T-box transcription factor Tbx2 represses differentiation and formation of the cardiac chambers, *Dev. Dyn.* 229 (2004) 763–770.
- [94] J.R. Chen, B. Chatterjee, R. Meyer, J.C. Yu, J.L. Borke, C.M. Isales, M.L. Kirby, C.W. Lo, R.J. Bollag, Tbx2 represses expression of Connexin43 in osteoblastic-like cells, *Calcif. Tissue Int.* 74 (2004) 561–573.
- [95] J.D. Molkenin, The zinc finger-containing transcription factors GATA-4, -5, and -6. Ubiquitously expressed regulators of tissue-specific gene expression, *J. Biol. Chem.* 275 (2000) 38949–38952.
- [96] G.U. Ryffel, Mutations in the human genes encoding the transcription factors of the hepatocyte nuclear factor (HNF)1 and HNF4 families: functional and pathological consequences, *J. Mol. Endocrinol.* 27 (2001) 11–29.
- [97] J.M. Rukstalis, A. Kowalik, L. Zhu, D. Lidington, C.L. Pin, S.F. Konieczny, Exocrine specific expression of Connexin32 is dependent on the basic helix–loop–helix transcription factor Mist1, *J. Cell Sci.* 116 (2003) 3315–3325.

- [98] R. Mollaaghababa, W.J. Pavan, The importance of having your SOX on: role of SOX10 in the development of neural crest-derived melanocytes and glia, *Oncogene* 22 (2003) 3024–3034.
- [99] L.J. Joseph, M.M. Le Beau, G.A. Jamieson Jr., S. Acharya, T.B. Shows, J.D. Rowley, V.P. Sukhatme, Molecular cloning, sequencing, and mapping of EGR2, a human early growth response gene encoding a protein with “zinc-binding finger” structure, *Proc. Natl. Acad. Sci. U. S. A.* 85 (1988) 7164–7168.
- [100] P. Chavrier, M. Zerial, P. Lemaire, J. Almendral, R. Bravo, P. Charnay, A gene encoding a protein with zinc fingers is activated during G0/G1 transition in cultured cells, *EMBO J.* 7 (1988) 29–35.
- [101] P. Chavrier, C. Vesque, B. Galliot, M. Vigneron, P. Dolle, D. Duboule, P. Charnay, The segment-specific gene Krox-20 encodes a transcription factor with binding sites in the promoter region of the Hox-1.4 gene, *EMBO J.* 9 (1990) 1209–1218.
- [102] P. Topilko, S. Schneider-Maunoury, G. Levi, A. Baron-Van Evercooren, A.B. Chennoufi, T. Seitanidou, C. Babinet, P. Charnay, Krox-20 controls myelination in the peripheral nervous system, *Nature* 371 (1994) 796–799.
- [103] L.E. Warner, P. Mancias, I.J. Butler, C.M. McDonald, L. Keppen, K.G. Koob, J.R. Lupski, Mutations in the early growth response 2 (EGR2) gene are associated with hereditary myelinopathies, *Nat. Genet.* 18 (1998) 382–384.
- [104] S. Jungbluth, K. Willecke, J. Champagnat, Segment-specific expression of connexin31 in the embryonic hindbrain is regulated by Krox20, *Dev. Dyn.* 223 (2002) 544–551.
- [105] S.J. Lye, B.J. Nicholson, M. Mascarenhas, L. MacKenzie, T. Petrocelli, Increased expression of connexin-43 in the rat myometrium during labor is associated with an increase in the plasma estrogen:progesterone ratio, *Endocrinology* 132 (1993) 2380–2386.
- [106] L. Chow, S.J. Lye, Expression of the gap junction protein connexin-43 is increased in the human myometrium toward term and with the onset of labor, *Am. J. Obstet. Gynecol.* 170 (1994) 788–795.
- [107] T. Petrocelli, S.J. Lye, Regulation of transcripts encoding the myometrial gap junction protein, connexin-43, by estrogen and progesterone, *Endocrinology* 133 (1993) 284–290.
- [108] E. Oltra, I. Pfeifer, R. Werner, Ini, a small nuclear protein that enhances the response of the connexin43 gene to estrogen, *Endocrinology* 144 (2003) 3148–3158.
- [109] A. Stock, H. Sies, Thyroid hormone receptors bind to an element in the connexin43 promoter, *Biol. Chem.* 381 (2000) 973–979.
- [110] J.A. Mitchell, C. Ou, Z. Chen, T. Nishimura, S.J. Lye, Parathyroid hormone-induced up-regulation of connexin-43 messenger ribonucleic acid (mRNA) is mediated by sequences within both the promoter and the 3′(untranslated region of the mRNA, *Endocrinology* 142 (2001) 907–915.
- [111] D. Martin, T. Tawadros, L. Meylan, A. Abderrahmani, D.F. Condorelli, G. Waeber, J.A. Haefliger, Critical role of the transcriptional repressor neuron-restrictive silencer factor in the specific control of connexin36 in insulin-producing cell lines, *J. Biol. Chem.* 278 (2003) 53082–53089.
- [112] M.A. Ozog, S.M. Bernier, D.C. Bates, B. Chatterjee, C.W. Lo, C.C. Naus, The complex of ciliary neurotrophic factor-ciliary neurotrophic factor receptor alpha up-regulates connexin43 and intercellular coupling in astrocytes via the Janus tyrosine kinase/signal transducer and activator of transcription pathway, *Mol. Biol. Cell* 15 (2004) 4761–4774.
- [113] M.P. Piechocki, R.D. Burk, R.J. Ruch, Regulation of connexin32 and connexin43 gene expression by DNA methylation in rat liver cells, *Carcinogenesis* 20 (1999) 401–406.
- [114] L.W. Tan, T. Bianco, A. Dobrovic, Variable promoter region CpG island methylation of the putative tumor suppressor gene Connexin 26 in breast cancer, *Carcinogenesis* 23 (2002) 231–236.
- [115] J.T. Chen, Y.W. Cheng, M.C. Chou, T. Sen-Lin, W.W. Lai, W.L. Ho, H. Lee, The correlation between aberrant connexin 43 mRNA expression induced by promoter methylation and nodal micrometastasis in non-small cell lung cancer, *Clin. Cancer Res.* 9 (2003) 4200–4204.
- [116] A. Hirai, T. Yano, K. Nishikawa, K. Suzuki, R. Asano, H. Satoh, K. Hagiwara, H. Yamasaki, Down-regulation of connexin 32 gene expression through DNA methylation in a human renal cell carcinoma cell, *Am. J. Nephrol.* 23 (2003) 172–177.
- [117] T. Yano, F. Ito, K. Kobayashi, Y. Yonezawa, K. Suzuki, R. Asano, K. Hagiwara, H. Nakazawa, H. Toma, H. Yamasaki, Hypermethylation of the CpG island of connexin 32, a candidate tumor suppressor gene in renal cell carcinomas from hemodialysis patients, *Cancer Lett.* 208 (2004) 137–142.
- [118] R. Singal, Z.J. Tu, J.M. Vanwert, G.D. Ginder, D.T. Kiang, Modulation of the connexin26 tumor suppressor gene expression through methylation in human mammary epithelial cell lines, *Anticancer Res.* 20 (2000) 59–64.
- [119] J. Loncarek, H. Yamasaki, P. Levillain, S. Milinkevitch, M. Mesnil, The expression of the tumor suppressor gene connexin 26 is not mediated by methylation in human esophageal cancer cells, *Mol. Carcinog.* 36 (2003) 74–81.
- [120] A. Schiavi, A. Hudder, R. Werner, Connexin43 mRNA contains a functional internal ribosome entry site, *FEBS Lett.* 464 (1999) 118–122.
- [121] A. Hudder, R. Werner, Analysis of a Charcot–Marie–Tooth disease mutation reveals an essential internal ribosome entry site element in the connexin-32 gene, *J. Biol. Chem.* 275 (2000) 34586–34591.
- [122] H. Lahlou, M. Fanjul, L. Pradayrol, C. Susini, S. Pyronnet, Restoration of functional gap junctions through internal ribosome entry site-dependent synthesis of endogenous connexins in density-inhibited cancer cells, *Mol. Cell. Biol.* 25 (2005) 4034–4045.
- [123] M. Kozak, New ways of initiating translation in eukaryotes? *Mol. Cell. Biol.* 21 (2001) 1899–1907.
- [124] H.A. Meijer, W.J. Dictus, E.D. Keuning, A.A. Thomas, Translational control of the *Xenopus laevis* connexin-41 5′-untranslated region by three upstream open reading frames, *J. Biol. Chem.* 275 (2000) 30787–30793.