

Multicentric Origin of Hemochromatosis Gene (*HFE*) Mutations

J. Rochette,^{1,*} J. J. Pointon,^{2,*} C. A. Fisher,³ G. Perera,^{4,+} M. Arambepola,⁴
D. S. Kodikara Arichchi,⁴ S. De Silva,⁵ J. L. Vandwalle,¹ J. P. Monti,¹ J. M. Old,³
A. T. Merryweather-Clarke,² D. J. Weatherall,² and K. J. H. Robson²

¹Génétique Médicale et Lab des Biomolécules, Université Jules Verne de Picardie, Amiens, France; ²MRC Molecular Haematology Unit, Institute of Molecular Medicine, and ³National Haemoglobinopathy Reference Service, Institute of Molecular Medicine, Headley Way, Headington, Oxford; ⁴Anuradhapura General Hospital, Anuradhapura, Sri Lanka; and ⁵Kurenegala General Hospital, Kurenegala, Sri Lanka

Summary

Genetic hemochromatosis (GH) is believed to be a disease restricted to those of European ancestry. In northwestern Europe, >80% of GH patients are homozygous for one mutation, the substitution of tyrosine for cysteine at position 282 (C282Y) in the unprocessed protein. In a proportion of GH patients, two mutations are present, C282Y and H63D. The clinical significance of this second mutation is such that it appears to predispose 1%–2% of compound heterozygotes to expression of the disease. The distribution of the two mutations differ, C282Y being limited to those of northwestern European ancestry and H63D being found at allele frequencies >5%, in Europe, in countries bordering the Mediterranean, in the Middle East, and in the Indian subcontinent. The C282Y mutation occurs on a haplotype that extends ≤ 6 Mb, suggesting that this mutation has arisen during the past 2,000 years. The H63D mutation is older and does not occur on such a large extended haplotype, the haplotype in this case extending ≤ 700 kb. Here we report the finding of the H63D and C282Y mutations on new haplotypes. In Sri Lanka we have found H63D on three new haplotypes and have found C282Y on one new haplotype, demonstrating that these mutations have arisen independently on this island. These results suggest that the *HFE* gene has been the subject of selection pressure. These selection pressures could be due to infectious diseases, environmental conditions, or other genetic disorders such as anemia.

Introduction

Genetic hemochromatosis (GH [MIM 235200]) is an autosomal recessive disease of iron overload (Bothwell et al. 1995). GH is easily treated by phlebotomy, leading to normal life expectancy if the disease is recognized before the onset of severe tissue damage (Niederer et al. 1996).

The identification of the 845 G→A (C282Y) mutation in the *HFE* gene (GenBank U60319) in 64%–100% of patients with GH (Feder et al. 1996; Beutler et al. 1996; Jouanolle et al. 1996; Jazwinska et al. 1996; Borot et al. 1997; Worwood et al. 1997; Porto et al. 1998) has led to population-screening studies (Merryweather-Clarke et al. 1997; Roth et al. 1997; Cullen et al. 1998). Much of this work has also included the analysis of a second mutation, 187 C→G (H63D), which appears to have a low penetrance (Feder et al. 1996).

Functional data suggest that the *HFE* protein with the C282Y mutation is unable to associate efficiently with β_2 -microglobulin and hence fails to reach the cell surface (Feder et al. 1997). The proposed role for *HFE* is the regulation of the interaction of the transferrin receptor with transferrin (Feder et al. 1998; Parkkila et al. 1997; Lebrón et al. 1998). Clearly, if the mutant protein is unable to reach the cell surface, then this regulatory feature is missing. The C282Y mutation is closely associated with GH in white populations. The role of a second mutation in the *HFE* gene, 187 C→G (H63D), is less clear. Current data suggest that this mutant protein can associate with β_2 -microglobulin and does reach the cell surface and that the defect lies in a failure to modify the affinity of the transferrin receptor for transferrin (Feder et al. 1998; Lebrón et al. 1998). This does not explain the low degree of penetrance associated with this mutation.

Both these mutations alter restriction-enzyme sites, providing easy methods for population screening. Allele frequencies for these two mutations have been published by a number of groups studying nonwhite populations, including Australian Aboriginals, Taiwanese Aboriginals, Indonesians, Chinese, and Pacific Islanders (Chang

Received August 6, 1998; accepted for publication February 1, 1999; electronically published March 12, 1999.

Address for correspondence and reprints: Dr. K. J. H. Robson, MRC Molecular Haematology Unit, Institute of Molecular Medicine, Headley Way, Headington, Oxford OX3 9DS, United Kingdom. E-mail: krobson@hammer.imm.ox.ac.uk

* These authors have contributed equally to this work.

† Present affiliation: Northwick Park Hospital, Harrow, United Kingdom.

© 1999 by The American Society of Human Genetics. All rights reserved.
0002-9297/99/6404-0017\$02.00

Table 1

Conditions for PCR Amplification of DNA Containing Diallelic Polymorphic Restriction-Enzyme Sites, the Relevant Restriction Enzyme, and the Product Sizes after Digestion for the Two Different Alleles

Polymorphism	Primer Sequences	Annealing Temperature (°C)	Extension Time (min)	Restriction Enzyme	Product Size(s) (bp)
-984	Forward, 5'-GATCCTTTAACCGAGGAGAT Reverse, 5'-CACTGGCCCACCTAAAT	54°C	1	<i>BbvI</i>	G: 511, 56 C: 567
S65C	Forward, 5'-TCTGTCTAATCATGAGTATT Reverse, 5'-CTTGCTGTGGTTGTGATTTTCC	52	1	<i>HinfI</i>	S: 369, 70, 68, 8 C: 435, 70, 8
IVS 2 (+5)	Forward, 5'-ACATGGTTAAGGCCTGTTG Reverse, 5'-TGCCACTAGAGTATAGGGGC	56	1	<i>RsaI</i>	T: 556, 245, 19 C: 396, 245, 160, 19
IVS 4 (-44)	Forward, 5'-TGTCCTCTCTGTAGCTTGT Reverse, 5'-TTCTGTCTCCCAGGGAGCT	55	1	<i>Sau96I</i>	T: 523, 194, 108 C: 305, 218, 194, 108
IVS5 (-47)	Forward, 5'-CCTGAACATCTGTGGTGTAG Reverse, 5'-TGGGACTACAGGCGTCTGC	56	1.5	<i>BanI</i>	G: 680, 440, 307, 115 A: 967, 404, 151
Poly A +5	Forward, 5'-CTTGGGGATTCTTCCATCT Reverse, 5'-CCGTAAGACAAAATGTAAAG	55	1.5	<i>RsaI</i>	C: 1,350, 367, 301, 123 T: 1,350, 424, 367

et al. 1997; Merryweather-Clarke et al. 1997; Cullen et al. 1998).

The population of Burma (Myanmar) is extremely heterogeneous, because of multiple migrations by different ethnic groups who have entered Burma from Tibet in the north and from east of the Mekong river. Burmans form the main ethnic group (65%) (Enriquez 1978). Historically, Khmers have entered Burma, Laos, and Kampuchea from the northeast. The island of Sri Lanka too has been subject to many population migrations. The original inhabitants (the Veddahs) represent a minor part of the present population. The largest ethnic groups now on the island originated from nearby India. The Sinhalese are thought to have originated from northeastern India at ~500 B.C. and represent the largest sector of the current population. The Tamils were from southern India and arrived in Sri Lanka mainly by a succession of invasions between the 3d and 12th centuries A.D. We report here the results of screening for these two mutations in 84 unrelated Burmese and 54 unrelated Khmer from Laos and Cambodia who are living in France as first-generation immigrants, as well as the results of further data from Sri Lanka that suggest that HFE mutations have arisen in more than one population.

Subjects and Methods

Subjects

DNA was prepared from 84 unrelated Burmese from a thalassemia study and from 54 unrelated Khmer from Laos and Cambodia who were living in France as first-generation immigrants. The samples from Sri Lanka formed part of a large study investigating the interaction of β -thalassemia with hemoglobin E in the context of iron overload. French DNA samples were used as con-

trols and represent a European population. Appropriate informed consent was given when the blood samples were collected for DNA analysis.

Methods

DNA was extracted from blood samples by standard methods. PCR amplifications of the *HFE* gene containing the H63D and C282Y mutations and analysis of the PCR products were performed as described elsewhere (Merryweather-Clarke et al. 1997).

Three diallelic polymorphisms—IVS 2 (+5), IVS 4 (-44), and IVS 5 (-47)—have been reported for the *HFE* gene (Beutler and West 1997). We have modified the PCR conditions to include internal control restriction-enzyme sites in the amplified product. Primer sequences and PCR conditions are given in table 1. The rare exonic polymorphism S65C has been described and shows no association with disease (Henz et al. 1997); PCR conditions for determining this are given in table

Table 2

HFE Mutations and Polymorphisms, with Nucleotide Changes and Their Positions within *HFE*

POLYMORPHISM	NUCLEOTIDE CHANGE	POSITION	
		Relative to Initiating ATG	In <i>HFE</i>
-984	G→C	-1206	5' Non-coding
H63D	C→G	3513	Exon 2
S65C	A→T	3519	Exon 2
IVS 2 (+5)	T→C	3670	Intron 2
C282Y	G→A	5473	Exon 4
IVS 4 (-44)	T→C	5635	Intron 4
IVS 5 (-47)	G→A	6699	Intron 5
Poly A +5	C→T	9378	Exon 7

1. Two further polymorphisms have been identified by sequencing and are described in the present study: -984 (G \rightarrow C) and poly A +5 (C \rightarrow T). PCR conditions and restriction-enzyme details are given in table 1. The relative positions of the polymorphisms used in the present study are given in table 2.

All the polymorphic sites were determined by PCR amplification followed by restriction-enzyme digestion of the products. All PCR reactions were performed as 25- μ l reactions in microtiter plates by a Hybaid thermal cycler, followed by digestion with the appropriate enzyme at 37°C for ≥ 4 h. Amplifications were performed by use of 0.625 units of AmpliTaq DNA polymerase (Perkin-Elmer) in a buffer containing 1.5 mM MgCl₂, 10 mM Tris-HCl pH 8.3 at 25°C, 50 mM KCl, 100 μ M dNTPs, and 50 ng of each primer, except for the IVS 5 (-47) reaction, which was performed by use of the Boehringer Expand High Fidelity PCR kit (Roche Diagnostics). All products were resolved on 2% agarose gels, except those for the -984 G \rightarrow C polymorphism, which were resolved by use of 3% agarose gels. Restriction enzymes were used in accordance with the manufacturer's instructions.

The microsatellite markers D6S105, D6S1260, and D6S1558 were amplified as described elsewhere (Weber et al. 1991; Raha-Chowdhury et al. 1995; Dib et al. 1996), except that the forward primer was labeled with T4 polynucleotide kinase and [³³P] γ -ATP prior to PCR amplification. Products were resolved on 6% denaturing polyacrylamide gels, and the product sizes were deduced by use of both sequencing ladders and control samples of known size. The β -globin-gene haplotype analysis was performed as described elsewhere (Varawalla et al. 1992; Flint et al. 1993).

Results

The 845 G \rightarrow A transition was absent from all ethnic groups from Southeast Asia that were studied (table 3). This result is consistent with the hypothesis that this mutation is of northern European origin. The 187 C \rightarrow G transversion is present and gives an overall allele frequency of 2.9%, with a nearly equal distribution in all ethnic groups (table 3). This result is consistent with the observations of others (Merryweather-Clarke et al. 1997; Cullen et al. 1998), who have found a similar frequency among Hong Kong Chinese and Indonesians and in both northern and southern Chinese. This allele frequency is much lower than either that in European populations (average 13.6%) or those in ethnic groups from northern and eastern Africa (8.9% and 9.4%, respectively) (Merryweather-Clarke et al. 1997; Roth et al. 1997). High allele frequencies have been observed both in Saudi Arabia and the Indian subcontinent (8.5% and 8.4%, respectively) (Merryweather-Clarke et al.

Table 3

Allele Frequencies for C282Y and H63D Mutations in Southeast Asian Chromosomes

ETHNIC GROUP	No. OF		
	Individuals	845 A	187 G
Burma	52	0	2
Karen	4	0	1
Burman/Karen	12	0	1
Burman/Chinese	11	0	1
Burman/Indian	4	0	0
Khmer	54	0	3
Total	137 (274 alleles)	0 (0 alleles)	8 (2.9% of alleles)

1997). The highest allele frequencies for the 187 C \rightarrow G mutation have been reported for regions bordering the Mediterranean (Merryweather-Clarke et al. 1997; Roth et al. 1997).

These results for H63D could be explained by gene flow between peoples around the Mediterranean, spreading into the Indian subcontinent. The HLA data reported by Cullen et al. (1998) suggest (a) that it is unlikely that this mutation was introduced into Southeast Asia with European chromosomes and (b) that it predates the C282Y mutation. It could be inferred from this that the 187 C \rightarrow G mutation may well have occurred at least twice—once in the Mediterranean and once in Asia.

To demonstrate this, we have haplotyped individuals who carry the H63D mutation, for three diallelic polymorphisms in the *HFE* gene (Beutler and West 1997). Of the five individuals from Burma who were H63D heterozygotes, all had a combination of alleles compatible with haplotype 6—(IVS 2 (+4) C, IVS 4 (-44) T, IVS 5 (-47) A [hereafter, "CTA"]) (Beutler and West 1997)—that is tightly associated with European chromosomes carrying the H63D mutation. Only one individual could have carried the H63D chromosome bearing haplotype 1 (TTG), a combination that we have found in Sri Lanka. In a study using both European and Asian chromosomes, H63D was found only in association with haplotype 6 (Beutler and West 1997).

Since H63D was present at such a low frequency in the Burmese and Khmer samples, we extended the study by examining a selection of Sri Lankan chromosomes in which the H63D allele frequency is $\sim 10\%$ (Merryweather-Clarke et al. 1997). Of the 14 unrelated Sri Lankan chromosomes that carried the H63D mutation, 6 had a combination of alleles compatible with haplotype 6 (CTA). Since there were two H63D homozygotes in the Sri Lankan samples, it was possible to conclude that H63D occurred on either haplotypes 1 (TTG), 2 (TTA), and 5 (CTG) or haplotypes 1 (TTG), 5 (CTG), and 6 (CTA) (fig. 1). The Sri Lankan samples also formed

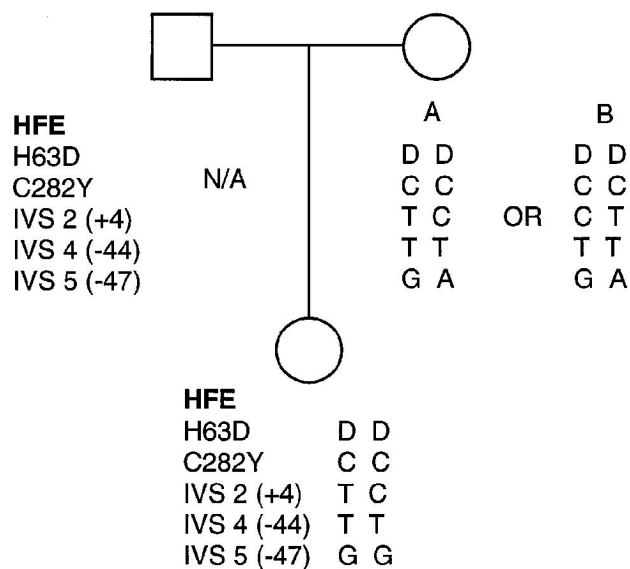

Figure 1 Sri Lankan pedigree showing homozygosity for H63D, in two generations. Unfortunately, the father was unavailable for study, since this family lives close to the Jaffna Peninsula. The mother has two possible haplotype combinations defined as A or B. The child is homozygous for the markers tested except IVS4 (-44); thus she carries H63D chromosomes bearing haplotypes 1 and 5.

part of a larger family study, so it was possible to assign haplotypes in a further set of chromosomes. One of 14 Sri Lankan chromosomes was haplotype 2 (TTA) (fig. 2), 2 were haplotype 5 (CTG), and 1 was haplotype 1 (TTG) (fig. 1). Of the chromosomes that could not be assigned unambiguous haplotypes, haplotypes 1, 2, and 5 were possible on 5, 4, and 5 chromosomes, respectively.

While sequencing the *HFE* gene from different chromosomes, we found two further diallelic polymorphisms that lend themselves to restriction-enzyme analysis. The first polymorphism (-984 G→C) lies 984 nucleotides upstream of the start of transcription, and the second polymorphism (poly A +5 C→T) lies 5 nucleotides beyond the poly A adenylation signal. These two polymorphisms can therefore be used to extend the haplotypes described by Beutler and West (1997). We have screened a selection of chromosomes for these polymorphisms; the results are shown in table 4, together with the results of the screening of chromosomes for H63D, S65C, C282Y and for the three diallelic polymorphisms used in the haplotype analysis. As has been found in other studies (e.g., Feder et al. 1996), the two mutations C282Y and H63D were not found on the same chromosome.

One of the Sri Lankan samples was from a C282Y/

H63D compound heterozygote (fig. 2). Thus far, the C282Y mutation has only been found associated with haplotype 1 (TTG), when the haplotyping method of Beutler and West (1997) has been used. It has been assumed that the C282Y mutation will only be found on a chromosome bearing haplotype 1 (TTG), since the C282Y mutation has been thought to have occurred only once. On the basis of our results, it can be inferred that H63D is associated with haplotype 2 (TTA) and that C282Y is associated with haplotype 5 (CTG), which Beutler and West found on 1.9% of their Asian chromosomes (Beutler and West 1997). This individual is from an orthodox Sinhalese background, so it is unlikely that there will be Tamil or Muslim chromosomes segregating in this pedigree.

Haplotypes 1 and 5 differ at one position, where a C (IVS 2 (+5)) is substituted for a T. We therefore extended

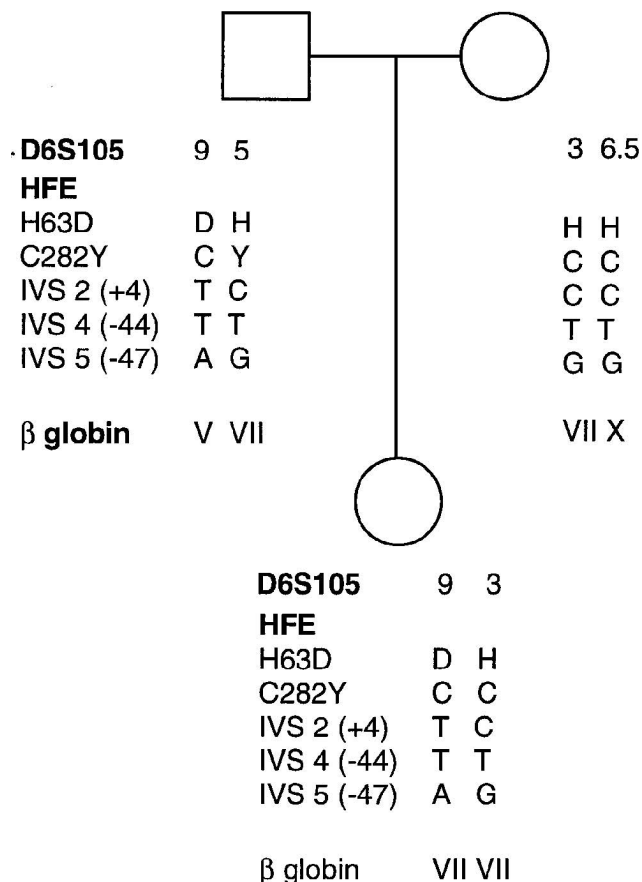

Figure 2 Sri Lankan pedigree in which mutations C282Y and H63D are segregating with haplotypes 5 (CTG) and 2 (TTA), respectively. The father is a compound heterozygote for the two mutations, and the mother is homozygous at the five loci tested; thus the daughter clearly has inherited the H63D mutation from her father, on a chromosome bearing haplotype 2.

Table 4

Allele Frequencies of HFE Mutations and Polymorphisms in Southeast Asians, Sri Lankans, and Europeans

ORIGIN	ALLELE FREQUENCY [No. OF CHROMOSOMES ASSESSED], FOR										
	-984 G→C	H63D	S65C	IVS 2 (+5) T→C	C282Y	IVS 4 (-44) T→C	IVS 5 (-47) G→A	Poly A (+5) C→T			
Burmese Karen	.714 G [20]	.970 H [161]	1.000 S [28]	.531 T [17]	1.000 C [166]	.679 T [19]	.393 G [9]	.636 C [14]			
	.286 C [8]	.030 D [5]	.000 C	.469 C [15]	.000 Y	.321 C [9]	.607 A [17]	.364 T [8]			
Sri Lankans	.350 G [42]	.892 H [116]	1.000 S [126]	.662 T [86]	.992 C [129]	.798 T [99]	.797 G [94]	.545 C [36]			
	.650 C [78]	.108 D [14]	.000 C	.338 C [44]	.008 Y [1]	.202 C [25]	.203 A [24]	.455 T [30]			
Unaffected Europeans (French)	.486 G [107]	.795 H [167]	.984 S [126]	.601 T [125]	.980 C [198]	.918 T [180]	.250 G [3]	.677 C [107]			
	.514 C [113]	.205 D [43]	.016 C [2]	.399 C [83]	.020 Y [4]	.082 C [16]	.750 A [9]	.323 T [51]			

the haplotype analysis in this family, using microsatellite markers that have been used to define the extended European hemochromatosis haplotype (fig. 2). The peak of linkage disequilibrium lies on the proximal side of the *HFE* gene, extending ≤ 4.5 Mb (Feder et al. 1996). The microsatellite markers D6S1260 and D6S1558 lie proximal to the *HFE* gene and were uninformative, since all three family members were heterozygous for the same alleles. The family was informative for D6S105, a marker that lies 1.7 Mb proximal to the *HFE* gene (fig. 2). In this family, allele 5 of D6S105 segregates with the chromosome bearing the C282Y mutation. In populations of European descent, allele 8 is most commonly associated with GH chromosomes, having a gene frequency of .62 in patients and .12 in controls (Jazwinska et al. 1993). In populations of European descent, allele 5 of D6S105 has a gene frequency of .06–.07 in GH patients and .15–.18 in controls (Jazwinska et al. 1993; Worwood et al. 1994).

The β -globin gene was used as a second independent marker in this family, to confirm family relationships (fig. 2). The father and mother have β -globin haplotypes V and VII and β -globin haplotypes VII and X, respectively. Their child is homozygous for haplotype VII, carrying the β -thalassemia mutation, IVS1-5 (G \rightarrow C), and is affected with β -thalassemia.

Discussion

These data suggest that, in Asia, the H63D mutation in the *HFE* gene occurs on three haplotypes with which it is not associated in Europe and support the idea that the H63D mutation may have arisen more than once. In Europe, the H63D mutation is associated with haplotype 6 (CTA). In Sri Lanka, family studies have demonstrated that the H63D mutation has occurred on the following three new haplotype backgrounds: haplotype 1 (TTG), haplotype 2 (TTA), and haplotype 5 (CTG). Two of the haplotypes differ from haplotype 6 (CTA), for the IVS 2 (+5) polymorphism, which is 157 bp from the H63D mutation. Two of the three haplotypes differ from haplotype 6, for the third polymorphism, which is 3.2 kb from the H63D mutation. All these polymorphisms lie within the *HFE* gene. A major problem in identifying the *HFE* gene was the lack of recombination in the gene region—in particular, recombination between *HFE* and HLA-A—so it is unlikely that recombination is responsible for our observations. We also observed a chromosome bearing the C282Y mutation together with haplotype 5 (CTG), which differs, at one position, from haplotype 1 (TTG). This C \rightarrow T nucleotide change is only 1.8 kb from the C282Y mutation. Together, these data suggest that, in Sri Lanka, both the C282Y mutation and the H63D mutation have arisen independently from the mutations occurring in Europe.

This is the first report of the C282Y mutation occur-

ring on a chromosome that clearly does not bear the classic haplotype associated with hemochromatosis patients from Europe. Our results suggest that there is or has been selection pressure favoring this mutation, making genetic drift an unlikely explanation. The selection pressures could be single or multiple. Wild-type HFE is expressed at the cell surface. One could speculate that this protein is the receptor for some infectious agent; a similar suggestion has been proposed with regard to the cystic fibrosis transmembrane regulator (CFTR) protein (Pier et al. 1998). It has been demonstrated that *Salmonella typhi*, the agent for typhoid fever, uses CFTR to enter wild-type intestinal epithelial cells, entering cells heterozygous for the common cystic fibrosis $\Delta F508$ mutation inefficiently and failing to enter cells homozygous for the $\Delta F508$ mutation (Pier et al. 1998). A similar mechanism involving an infectious agent could explain the selection of the C282Y-mutant form of HFE, since this form of the protein does not reach the cell surface because it cannot associate correctly with β_2 -microglobulin. The region of the protein that might be involved could be exon 3, which encodes the $\alpha 2$ domain where the H63D mutation is found. Since this mutation is reported to be of low penetrance and causes disease in only a proportion of patients who are H63D/C282Y compound heterozygotes and in even fewer H63D homozygotes, there must be little heterozygote or homozygote disadvantage. Until now, it has been assumed that the selective advantage conferred by *HFE* mutations was the prevention of iron deficiency; this would include protection against anemia due to hookworm infestation, malaria, multiple pregnancies, a diet lacking in iron, or any combination of these factors. If this were solely the case, then one might expect that one or more of the *HFE* mutations would have reached fixation in countries where there are high levels of anemia; however, this has yet to be observed. On the basis of our current understanding, it can be inferred that, for either mutation, there is little reproductive disadvantage to C282Y homozygotes and even less to heterozygotes, a situation that would be expected to favor selection for these mutations if protection against anemia were so advantageous.

GH has been recognized only among populations of northern European origin. Thalassemia, a serious disease both in peoples of Mediterranean and in peoples of Asian descent, is a major contributory factor in iron overload. Screening for the 187 G allele in thalassemic patients may be relevant, since this mutation may be another contributory factor in iron overload.

Acknowledgments

This work has been supported by the Wellcome Trust and the European Community (contract BMH4-CT96-0994). We thank Dr. S. L. Thein for making available the Burmese DNA

samples. J.R. thanks the Université de Picardie Jules Verne (Prof. M. Fliniaux) and the Direction Regionale de la Recherche et de la Technologie (Dr. M. Freville) for continued support.

Electronic-Database Information

Accession numbers and URLs for data in this article are as follows:

GenBank, <http://www.ncbi.nlm.nih.gov/Web/Genbank> (for HFE)

Online Mendelian Inheritance in Man (OMIM), <http://www.ncbi.nlm.nih.gov/Omim> (for GH [MIM 235200])

References

- Beutler E, Gelbart T, West C, Lee P, Adams M, Blackstone R, Pockros P, et al (1996) Mutation analysis in hereditary hemochromatosis. *Blood Cells Mol Dis* 22:187–194
- Beutler E, West C (1997) New diallelic markers in the HLA region of chromosome 6. *Blood Cells Mol Dis* 23:219–229
- Borot N, Roth M-P, Malfroy L, Demangel C, Vinel J-P, Pascal J-P, Coppin H (1997) Mutations in the MHC class I-like gene for hemochromatosis in French patients. *Immunogenetics* 45:320–324
- Bothwell TH, Charlton RW, Motulsky AG (1995) Hemochromatosis. In: Scriver CR, Beaudet AL, Sly WS, Valle D (eds) *The metabolic and molecular bases of inherited disease*. McGraw-Hill, New York, pp 2237–2269
- Chang J-G, Liu T-C, Lin S-F (1997) Rapid diagnosis of the HLA-H gene Cys 282 Tyr mutation in hemochromatosis by polymerase chain reaction—a very rare mutation in the Chinese population. *Blood* 89:3492–3493
- Cullen LM, Gao X, Easteal S, Jazwinska EC (1998) The hemochromatosis 845 G→A and 187 C→G mutations: prevalence in non-Caucasian populations. *Am J Hum Genet* 62:1403–1407
- Dib C, Fauré S, Fizames C, Samson D, Drout N, Vignal A, Millasseau P, et al (1996) A comprehensive genetic map of the human genome based on 5,264 microsatellites. *Nature* 380:152–154
- Enriquez CMD (1978) *Races of Burma*. Government of India Central Publication Department, Calcutta
- Feder JN, Gnirke A, Thomas W, Tsuchihashi Z, Ruddy DA, Basava A, Dormishian F, et al (1996) A novel MHC class I-like gene is mutated in patients with hereditary haemochromatosis. *Nat Genet* 13:399–408
- Feder JN, Penny DN, Irrinki A, Lee VK, Lebrón JA, Watson N, Tsuchihashi Z, et al (1998) The hemochromatosis gene product complexes with the transferrin receptor and lowers its affinity for ligand binding. *Proc Natl Acad Sci USA* 95:1472–1477
- Feder JN, Tsuchihashi Z, Irrinki A, Lee VK, Mapa FA, Morikang E, Prass CE, et al (1997) The hemochromatosis founder mutation in HLA-H disrupts β_2 -microglobulin interaction and cell surface expression. *J Biol Chem* 272:14025–14028
- Flint J, Harding RM, Boyce AJ, Clegg JB (1993) *The population genetics of the haemoglobinopathies*. Bailliere Tindall, London
- Henz S, Reichen J, Liechti-Gallati S (1997) HLA-H gene mutations and haemochromatosis: the likely association of H63D with mild phenotype and the detection of S65C, a novel variant in exon 2. *J Hepatol* 26 Suppl 1:57
- Jazwinska EC, Cullen LM, Busfield F, Pyper WR, Webb SI, Powell LP, Morris CP, et al (1996) Haemochromatosis and HLA-H. *Nat Genet* 14:249–251
- Jazwinska EC, Lee SC, Webb SI, Halliday JW, Powell LW (1993) Localization of the hemochromatosis gene close to D6S105. *Am J Hum Genet* 53:347–352
- Jouanolle AM, Gandon G, Blayau M, Campion ML, Yaouanq J, Mosser J, Fergelot P, et al (1996) Haemochromatosis and HLA-H. *Nat Genet* 14:251–252
- Lebrón JA, Bennett MJ, Vaughn DE, Chirino JA, Snow PM, Mintier GA, Feder JN, et al (1998) Crystal structure of the hemochromatosis protein HFE and characterization of its interaction with the transferrin receptor. *Cell* 93:111–123
- Merryweather-Clarke AT, Pointon JJ, Shearman JD, Robson KJH (1997) Global prevalence of putative haemochromatosis mutations. *J Med Genet* 34:275–278
- Niederrau C, Fischer R, Purschel A, Stremmel W, Haussinger D, Strohmeyer G (1996) Long-term survival in patients with hereditary hemochromatosis. *Gastroenterology* 110:1107–1119
- Parkkila S, Waheed A, Britton RS, Bacon BR, Zhou XY, Tomatsu S, Fleming RE, et al (1997) Association of the transferrin receptor in human placenta with HFE, the protein defective in hereditary hemochromatosis. *Proc Natl Acad Sci USA* 94:13198–13202
- Pier GB, Grout M, Zaidi T, Meluleni G, Mueschenborn SS, Banting G, Ratcliff R, et al (1998) Salmonella typhi uses CFTR to enter intestinal epithelial cells. *Nature* 393:79–82
- Porto G, Alves H, Rodrigues P, Cabeda JM, Portal C, Ruivo A, Justiça B, et al (1998) Major histocompatibility complex class I associations in iron overload: evidence for a new link between the H63D mutation, HLA-A29, and non-classical forms of hemochromatosis. *Immunogenetics* 47:404–410
- Raha-Chowdhury R, Bowen DJ, Stone C, Pointon JJ, Terwilliger JD, Shearman JD, Robson KJH, et al (1995) New polymorphic microsatellite markers place the haemochromatosis gene telomeric to D6S105. *Hum Mol Genet* 4:1869–1874
- Roth M-P, Giraldo P, Hariti G, Poloni ES, Sanchez-Mazas A, De Stefano GF, Dugoujon J-M, et al (1997) Absence of the hemochromatosis gene Cys282Tyr mutation in three ethnic groups from Algeria (Mzab), Ethiopia, and Senegal. *Immunogenetics* 46:222–225
- Varawalla NY, Fitches AC, Old JM (1992) Analysis of β -globin gene haplotypes in Asian Indians: origin and spread of β -thalassaemia on the Indian subcontinent. *Hum Genet* 90:443–449
- Weber JL, Kwitek AE, May PE, Zoghbi HY (1991) Dinucleotide repeat polymorphism at the D6S105 locus. *Nucleic Acids Res* 19:968
- Worwood M, Raha-Chowdhury R, Dorak MT, Darke C, Bowen DJ, Burnett AK (1994) Alleles at D6S265 and D6S105 define a haemochromatosis specific-genotype. *Br J Haematol* 86:863–866
- Worwood M, Shearman JD, Wallace DF, Dooley JS, Merryweather-Clarke AT, Pointon JJ, Rosenberg WMC, et al (1997) A simple genetic test identifies 90% of UK patients with haemochromatosis. *Gut* 41:841–844