

Contents lists available at [ScienceDirect](http://ScienceDirect.com)

Science of the Total Environment

journal homepage: www.elsevier.com/locate/scitotenv

Human and bovine viruses in the Milwaukee River watershed: Hydrologically relevant representation and relations with environmental variables

S.R. Corsi ^{a,*}, M.A. Borchardt ^b, S.K. Spencer ^b, P.E. Hughes ^a, A.K. Baldwin ^a^a U.S. Geological Survey, Wisconsin Water Science Center, Middleton, WI 53562, United States^b U.S. Department of Agriculture, Agricultural Research Service, 2615 Yellowstone Dr., Marshfield, WI 54449, United States

HIGHLIGHTS

- Hydrologic conditions, precipitation, and season explained variability of viruses.
- Human and bovine viruses were more prevalent during runoff periods than during low-flow periods.
- An automated sampling system provided hydrologically relevant samples over long durations.

ARTICLE INFO

Article history:

Received 4 March 2014

Received in revised form 15 May 2014

Accepted 16 May 2014

Available online 6 June 2014

Editor: Thomas Kevin V

Keywords:

Human viruses

Watershed

Hydrologic event

Automated sampling

Seasonality

ABSTRACT

To examine the occurrence, hydrologic variability, and seasonal variability of human and bovine viruses in surface water, three stream locations were monitored in the Milwaukee River watershed in Wisconsin, USA, from February 2007 through June 2008. Monitoring sites included an urban subwatershed, a rural subwatershed, and the Milwaukee River at the mouth. To collect samples that characterize variability throughout changing hydrologic periods, a process control system was developed for unattended, large-volume (56–2800 L) filtration over extended durations. This system provided flow-weighted mean concentrations during runoff and extended (24-h) low-flow periods. Human viruses and bovine viruses were detected by real-time qPCR in 49% and 41% of samples ($n = 63$), respectively. All human viruses analyzed were detected at least once including adenovirus (40% of samples), GI norovirus (10%), enterovirus (8%), rotavirus (6%), GII norovirus (1.6%) and hepatitis A virus (1.6%). Three of seven bovine viruses analyzed were detected including bovine polyomavirus (32%), bovine rotavirus (19%), and bovine viral diarrhea virus type 1 (5%). Human viruses were present in 63% of runoff samples resulting from precipitation and snowmelt, and 20% of low-flow samples. Maximum human virus concentrations exceeded 300 genomic copies/L. Bovine viruses were present in 46% of runoff samples resulting from precipitation and snowmelt and 14% of low-flow samples. The maximum bovine virus concentration was 11 genomic copies/L. Statistical modeling indicated that stream flow, precipitation, and season explained the variability of human viruses in the watershed, and hydrologic condition (runoff event or low-flow) and season explained the variability of the sum of human and bovine viruses; however, no model was identified that could explain the variability of bovine viruses alone. Understanding the factors that affect virus fate and transport in rivers will aid watershed management for minimizing human exposure and disease transmission.

© 2014 Published by Elsevier B.V.

1. Introduction

Contamination of environmental waters by human pathogens, including enteric viruses, is recognized as a potential human health hazard to those using recreational waters (Wade et al., 2006, 2008), in drinking water systems (Borchardt et al., 2012), or even via crops

contaminated by irrigation (Bosch, 1998). The potential for contamination is large because there are over 100 human-specific viruses present in sewage and viruses are shed in feces of infected humans in concentrations on the order of 10^5 to 10^{11} viruses per gram (Bosch, 1998). Bovine viruses also have been detected in environmental waters and have most commonly been used to trace contamination from cattle farms (Fong et al., 2005; Ahmed et al., 2010), and suggest potential for transmission to cattle exposed to contaminated water sources. Virus contamination can impact groundwater quality (Abbaszadegan et al., 2003; Bradbury et al., 2013) as well as surface water quality (Tani et al., 1995; Jiang and Chu, 2004; Fong and Lipp, 2005).

* Corresponding author. Tel.: +1 608 821 3835.
E-mail address: srcorsi@usgs.gov (S.R. Corsi).

Sources of human viruses into environmental waters are limited, although the degree of contamination can be strongly variable in both time and space (Rutsch et al., 2008). Sources include: treated wastewater effluent, partially treated wastewater effluent (from “blending” events), combined sewer overflows (CSO), sanitary sewer overflows (SSO), leaking sanitary and sewer lines, lateral pipes for public and private connections, and misconnected sanitary sewer lines. Septic systems can also introduce viruses to environmental waters when properly functioning (Alhajjar et al., 1988; DeBorde et al., 1998) or during periods of system failure (Borchardt et al., 2011). In addition, authorized application of septic system effluent to the land surface is common for routine septic system maintenance (WDNR, 2001, <http://www.legis.state.wi.us/rsb/code/nr/nr113.pdf>). Treated wastewater, CSOs, and SSOs are typically discharged directly to surface water systems, while leaking sanitary sewer lines and septic systems discharge to the groundwater system, and ultimately may travel laterally and be transported to surface waters. Bovine viruses are released to the environment in cattle manure in holding ponds, storage areas, or pastures, and are often widely distributed in agricultural areas when manure is land-applied for crop fertilization. Viruses in land-applied septage and manure can move by overland flow or drain tiles to surface waters (Fong and Lipp, 2005) and viruses can infiltrate soil to reach groundwater where they can be pumped back to the surface from wells, become inactivated, or travel through shallow groundwater and discharge as baseflow to surface water systems. In surface water, viruses can remain suspended and be transported with currents or be deposited into sediments which can act as a reservoir from which viruses can persist and be resuspended under certain environmental conditions (Bosch, 1998).

The survival, fate, and transport properties of viruses in the environment vary depending on virus type as well as the environmental conditions to which they are exposed (Schijven and Hassanizadeh, 2000; Rzezutka and Cook, 2004; John and Rose, 2005; Bosch, 1998). Potentially influential factors include temperature, desiccation, UV light exposure, inactivation by other microorganisms, hydrologic flow conditions, filtration or adsorption in porous media, adsorption to sediments, and deposition and resuspension in sediments. Human and bovine viruses do not replicate outside of their host, so once in the environment, consideration of survival and inactivation is important, but not growth. Due to the small size of viruses and the potentially long survival time in the environment, travel times in groundwater of months to years are relevant for delivery of viruses to drinking water wells or surface water resources. Survival in surface water is likely shorter than that in groundwater because of UV exposure, higher temperatures (depending on the time of year and location), and the opportunity for more interactions with other organisms that can inactivate viruses (Meixell et al., 2013).

Virus contamination has been documented in rivers under different conditions and settings. For example, human virus input to coastal areas from urban rivers in southern California was greatest during the rainy season (Jiang and Chu, 2004). Nine rivers with wastewater effluent influence and a wide range of land cover in the lower peninsula of Michigan were sampled one time during summer low-flow conditions and three rivers were positive for viable human enteric viruses (Jenkins et al., 2005). Bovine viruses were detected in wet- and dry-weather conditions in the Maroochy Coastal River in Australia (Ahmed et al., 2010) and were more prevalent during cool water temperatures than warm water temperatures in a study of the lower Altamaha River in Georgia, USA (Fong et al., 2005).

A key challenge in studying virus contamination of riverine ecosystems is collecting hydrologically relevant samples. With changes in flow from rainfall or snowmelt, contamination levels of many constituents will also change. In addition, diel changes in UV light exposure and temperature in a river likely result in diel variability in virus survival. This suggests that proper characterization of viruses must be accomplished by sampling in a hydrologically and temporally relevant manner over extended periods of time, but this can be difficult. Large volumes of water (typically > 100 L) must be filtered and some filtration methods

require pH adjustment of sample water before filtration. Because of these technical details, previous river sampling for viruses has commonly been limited to collection of large volume grab samples over relatively short periods of time (Noble and Fuhrman, 2001; Jiang and Chu, 2004; Fong et al., 2005; Jenkins et al., 2005; Aslan et al., 2011). Hydrologically relevant samples require sampling through low flow periods as well as entire runoff periods to capture all components of the hydrograph including the first flush, rising flow, peak flow, and receding flow periods. Virus inactivation likely differs between daylight and non-daylight periods, suggesting that 24 h would be a reasonable sampling duration during low-flow periods.

The objectives of the present study were to develop sampling techniques for hydrologically and temporally relevant virus sampling and to characterize virus occurrence and variability in three locations within the Milwaukee River watershed, Wisconsin: 1) an urban subwatershed where wastewater is municipally collected but the treated effluent is not discharged to the river; 2) a rural subwatershed where wastewater is treated primarily with septic systems; and 3) the Milwaukee River at the mouth into Lake Michigan, which represents combined urban and rural watershed inputs. A third objective was to relate virus occurrence to hydrologic and climatic conditions. Results provide further understanding of primary factors that influence virus presence in rivers and could lead to improved watershed management decisions for minimizing human exposure to waterborne viruses.

2. Methods

2.1. Monitored sites

Three streams within the Milwaukee River watershed in Wisconsin, USA were monitored for human and bovine viruses over a 17 month period, February 2007 to June 2008 (Table 1, Fig. 1). One site was composed mainly of rural land use (Cedar Creek) and the other was mainly urban land use (Underwood Creek). The third site was at the mouth of the Milwaukee River which includes a mix of different land uses. The Milwaukee River monitoring site was located downstream of input from Cedar and Underwood Creeks.

Flow-weighted composite samples were collected during low-flow periods and during periods of increased runoff due to rainfall and snowmelt (hereafter referred to as “runoff events”), resulting in event-mean virus concentrations. These sampling techniques require instantaneous flow measurements that are used to compute the volume of streamflow over time. Flow-weighted samples were collected by specifying the volume of streamflow between subsamples. The volume between subsamples varied by sampling period based on anticipated streamflow levels. With these methods, subsample collection frequency increases as streamflow increases. Runoff samples consisted of numerous 5 L subsamples to cover the entire event hydrograph (between 7 and 206 h sampling duration). Runoff-event sampling was initiated when water level became elevated above low flow, and sampling was ended after flow returned to near baseflow levels. Low-flow samples consisted of numerous 5 L subsamples collected over approximately 24 h. Exact sample volumes varied by sampling event (Table 1). Flow-weighted sampling allowed for straightforward total virus loading and unit-area loading computation as well as valid comparison among sampling locations.

2.2. Sample collection

Samples were collected using custom-designed automated large-volume virus sample collection and filtration systems that were housed at each monitoring site (Fig. 2). Remote telemetry allowed unattended operation for initiating and monitoring sampling. This allowed sample coverage of entire runoff events and extended low-flow periods without deploying field personnel. A variable-speed peristaltic pump was used to pump water from the stream into the sampling system with a

Table 1

Land use, drainage area, and volumes sampled for virus monitoring in the three study watersheds during 2007 and 2008 in the Milwaukee River watershed, Wisconsin. Land cover compositions for each watershed were summarized using 2006 National Land Cover Database products (Fry et al., 2011).

Site name	USGS station ID	Drainage area (km ²)	Land use percentage			Hydrograph coverage: volume filtered (L) (number of subsamples)			Samples collected
			Urban	Agriculture	Natural areas	Minimum	Median	Maximum	
Cedar Creek	04086500	311	9.6	58	32	128 (26)	540 (108)	2750 (550)	20
Underwood Creek	04087088	47.1	87	4	9	56 (11)	186 (37)	481 (96)	20
Milwaukee River	04087170	2260	27	46	27	87 (17)	399 (80)	1420 (283)	23

tipping bucket flow meter to measure the flow rate. Flow rate was regulated to 1 L/min \pm 0.2 L/min with this system. Using a pH sensor and a second variable-speed peristaltic pump, dilute HCl (between 0.13 N and 0.5 N, depending on the site) was metered into the system, conditioning pH to levels of 6.75 \pm 0.25 for optimal virus recovery in the glass-wool filter. Each filter unit consisted of a prefilter (10-inch polypropylene string-wound filter cartridge (McMaster-Carr, Atlanta, GA), with a 10 μ m nominal pore size) to remove coarse material and a glass-wool filter for primary virus capture (Lambertini et al., 2008; Millen et al., 2012). Filter units were housed inside a refrigerator and kept chilled throughout the sampling process. Three ball valves were used to direct

flow between the bypass and the two filter units. A pressure transducer measured backpressure in the system, an indication of filter clogging. At a threshold pressure of 345 kPa (50 psi), the valves were triggered to direct flow to the second filter set.

The subsample automated sequence was as follows: initial back-flush of the system, high-speed forward-flush through the sampling line for 10 s after water reached the system, flow rate regulation, pH conditioning, triggering valves for filtration of stream water, triggering valves after filtration, and reversing the pump direction for a back-flush of the system. Once sampling was initiated, the prefilter and glass-wool filter remained filled with native stream water between subsamples and after sampling

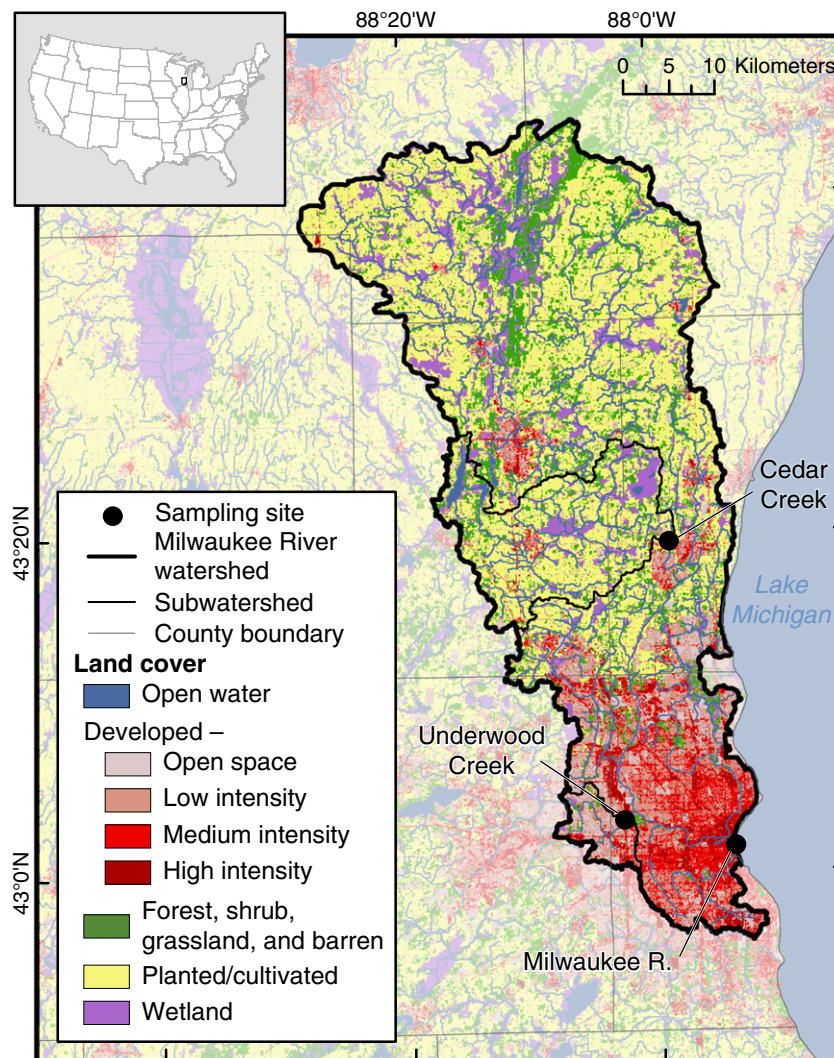

Fig. 1. Sampling locations and land cover in the Milwaukee River watershed. Map comprised of various spatial datasets: state boundaries (Instituto Nacional de Estadística Geografía e Informática et al., 2006), county boundaries (National Atlas of the United States, 2005), hydrography (U.S. Environmental Protection Agency and U.S. Geological Survey, 2005), land cover (Fry et al., 2011), and watershed boundaries (modified from Southeastern Wisconsin Regional Planning Commission, Environmental Division and GIS Division 2005).

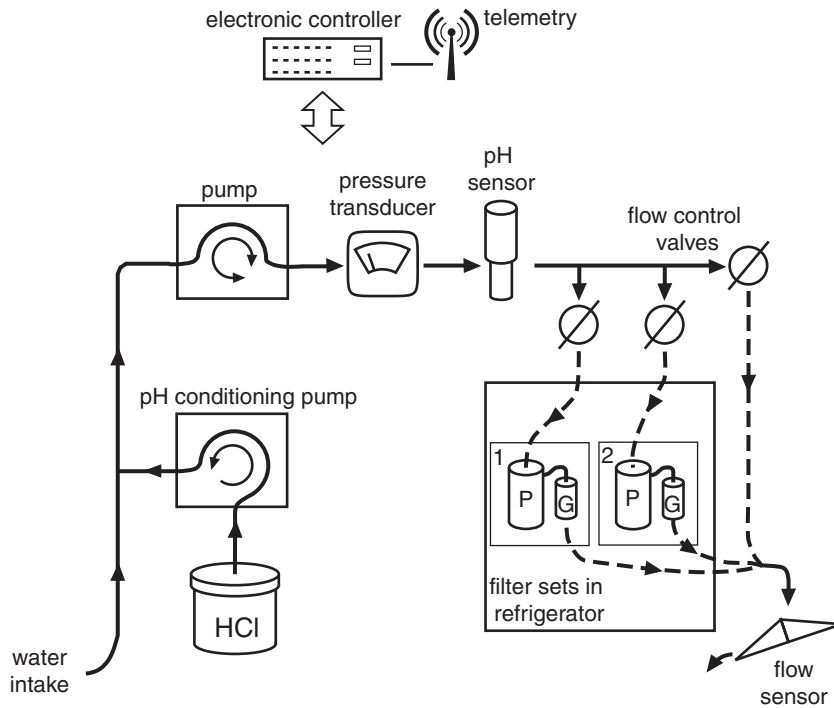

Fig. 2. Diagram of the automated large-volume virus sample collection and filtration system. “P” and “G” designations for the filter sets refer to prefilter and glass-wool filter, respectively.

events until opened for processing in the analytical laboratory. After each sampling event, the filter units were collected, placed in a plastic bag, sealed, and shipped to the analytical laboratory. Protective latex gloves

were worn throughout filter collection to prevent contamination. Fig. 3 shows an example of hydrograph coverage, pH conditioning, and system pressure throughout one sampling event.

Forty-three runoff event samples and 20 low-flow samples were collected during the study period. Mean sample volume was 376 L, and the mean number of subsamples per sample collected was 75.

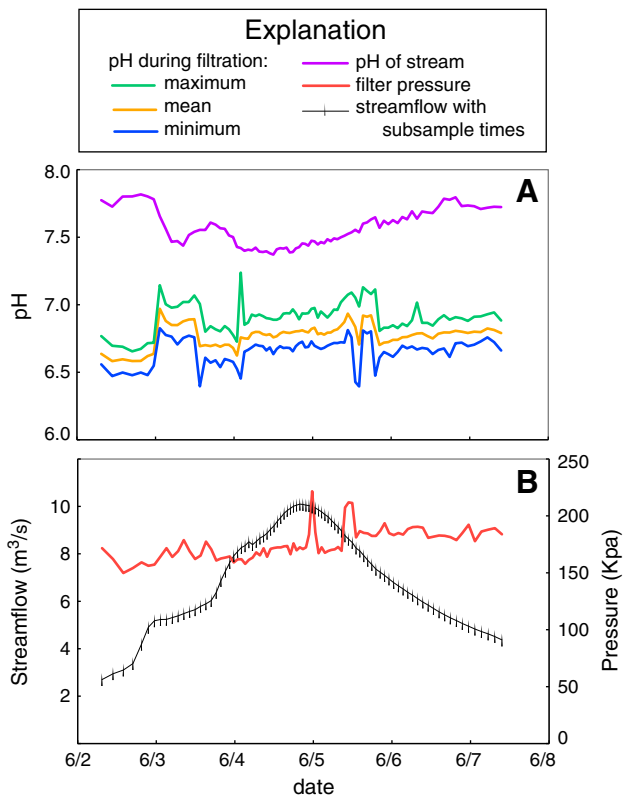

Fig. 3. Example of quality control results from the automated virus sample filtration process at Underwood Creek in June, 2007.

2.3. Virus analytical methods

Virus filters were shipped on ice overnight to the analytical laboratory and filters were eluted immediately upon arrival. Procedures for eluting viruses from the prefilters and glass-wool filters and for concentrating filter eluates by polyethylene glycol (PEG) precipitation were previously described (Lambertini et al., 2008; Millen et al., 2012). Eluates from the prefilter and glass-wool filter pair that composed a filter set were carried separately through the entire analytical process and the final results summed to calculate virus concentrations per sample. Throughout the study, 27% of human viruses and 47% of bovine viruses were captured in the prefilter. After PEG concentration, final concentrated sample volumes (FCSV) were stored at -80°C until nucleic acid extraction. Extraction was carried out using the QIAamp DNA blood mini kit and buffer AVL (Qiagen, Valencia, CA) as described previously (Borchardt et al., 2012).

All samples were analyzed for six human enteric viruses (adenovirus, enterovirus, norovirus genogroups I and II, hepatitis A virus, and rotavirus) and seven bovine enteric viruses (adenovirus, enterovirus, rotavirus group A, polyomavirus, coronavirus, and bovine viral diarrhea virus types 1 and 2) by real-time quantitative PCR and hydrolysis probes using the LightCycler 480 (Roche Diagnostics, Mannheim, Germany) and LightCycler 480 Probes Master kit (Roche Diagnostics). Human virus primers, probes, and standard curve performance are reported in Borchardt et al. (2012). Bovine virus primers, probes, standard curve performance, and bovine virus sources are reported in Table S1 and Table S2, Supporting information. qPCR reactions were performed in duplicate (see Borchardt et al., 2012 for RT-qPCR (two-step) and qPCR thermal conditions, reverse transcription procedure, the approach for

summarizing duplicate qPCR results, and the calculations for normalizing virus genomic copies to per liter volume sampled).

Every sample was measured for qPCR inhibition following methods described in Borchardt et al. (2012), and if necessary, inhibition was mitigated by dilution. Of the 126 study FCSVs (concentrated eluates from 63 pre-filters plus 63 glass wool filters) 79 required dilution. Every batch of reactions included the following controls: extraction positive and negative, no-template controls for reverse transcription and PCR master mixes, and a positive control for each virus seeded into a FCSV matrix blank at low copy number. All negative controls were negative (i.e., no crossing threshold) during the study. Five field blanks consisting of 10 L sterile phosphate buffer solution were collected through the auto-sampling system; all five were virus negative. Recovery controls were performed on one date (October 17, 2007) for each of the three monitoring sites following the procedure described in Lambertini et al. (2008). Among the three sites, mean (± 1 SD) poliovirus Sabin 3 recovery was $31\% \pm 31\%$, and mean adenovirus 41 recovery was $50\% \pm 22\%$.

Samples positive for enterovirus or adenovirus were identified to serotype by sequencing using the ABI Prism 3100 Genetic Analyzer and previously described methods (Borchardt et al., 2012).

Human enterovirus and adenovirus infectivity was evaluated by cell culture using three cell lines (BGMK, RD, and Caco-2) or two cell lines (Graham 293 and A549), respectively, as previously described (Borchardt et al., 2012). Only samples positive by qPCR for these viruses were evaluated. All cultures were held for six weeks and if cytopathic effect (CPE) was not observed, cell lysates from the two-week passage and the six-week culture were analyzed by qPCR (i.e., integrated cell culture – qPCR). If the number of virus genomic copies in the cell lysates was 10 times greater than the initial virus quantity added to the culture flask in the FCSV inoculum, evidence consistent with virus growth, the sample was designated as positive for infectious virus.

2.4. Data analysis

Virus occurrence and mean and maximum concentrations at each watershed during runoff events and during low-flow periods were compared using the Wilcoxon rank sum test. Results were explored further with multivariate regression using the sum of human viruses, the sum of bovine viruses, and the sum of all viruses as response variables. Individual virus types did not have high enough occurrence rates to warrant separate analysis. Predictor variables included a binary variable for indicating hydrologic condition (runoff event or low flow), antecedent baseflow, maximum flow during the sampling period, maximum flow difference during the sampling period, volume of streamflow during the sampling period, duration of sampling period, duration of runoff event (set to sampling period for low flow samples), rainfall depth for current runoff period, 1-, 2-, 3-, 5-, 7-, and 10-day antecedent rainfall depth, average rainfall intensity and 60-minute maximum rainfall intensity during the runoff event, mean cloud cover during the sampling period, mean air temperature during the sampling period, and a periodic seasonal term as given by the sine and cosine of T which is defined as 2π (julian day/365.25). Cloud cover and air temperature were from the Great Lakes Coastal Forecasting Center (Schwab and Bedford, 1999). All flow variables were divided by the drainage area to normalize by watershed size. The number of observations per site was not enough to warrant regression models for each individual site, so data was combined for the three sites with a predictor variable term to differentiate among sites.

Several factors were considered when choosing the multivariate regression technique, all arising from the nature of the virus data. The data had a considerable proportion of left-censored data (samples where viruses were not detected), so a technique that properly treats these data was preferred over those that require data imputation. There were a large number of predictor variables that could potentially be used in resulting models, so a reliable variable selection technique was needed.

There was a wide range of virus concentrations represented in the dataset, thereby needing a technique to differentiate between the magnitudes of concentrations.

A compromise between definition of the magnitude of concentrations and proper treatment of censored values was ultimately chosen by using the proportional odds logistic regression (POLR) modeling structure, a form of ordinal logistic regression. Ordinal logistic regression provides similar functionality to binary logistic regression, but includes greater than two categories in the response variable and recognizes the ordered nature of categories in the model structure. For example, in the case of virus concentrations for the present research, three categories are defined and used as the response variable: “not detected” < “detected at a medium concentration” < “detected at a high concentration”. Stepwise regression was used in the POLR algorithm with forward and backward selection to screen variables to assess which predictors had the greatest value in explaining variability of virus concentration categories. Variable selection began with the full model, and at each step one variable was removed or added. The variable that was removed or added was the one whose addition or removal did the most to reduce the Bayesian Information Criterion (BIC). If no such variable was found, then selection was considered complete. All statistical analyses were done using the R project for statistical computing using core functionality and the MASS package (Venables and Ripley, 2002; R Development Core Team, 2008).

Relations between virus concentrations and environmental variables were explored using POLR by defining ordered categorical variables from three data bins for each of the virus summations. These categorical variables were then used as the ordinal response variables. The first bin included all left-censored values. The second and third bins were divided at virus concentrations where natural break points occurred in a cumulative distribution curve. Concentrations used for this were 20.0 genomic copies/L for human viruses, 2.0 genomic copies/L for bovine viruses, and 14.0 genomic copies/L for the sum of all viruses. Resulting models provided a probability of occurrence for each of the three virus bins for any given combination of predictor variables. The bin with the largest probability of occurrence for that sample was chosen as the most likely outcome.

Flux of viruses was computed based on the loading of viruses (stream-water volume \times virus concentration) divided by the duration of the sampling period for each sample. These values were then normalized by drainage area to result in a flux per unit drainage area of each watershed (units of genomic copies/km²/h). This could also be referred to as a virus yield per unit time.

3. Results

A total of 63 samples were collected over a 17-month period across the three sampling locations for human and bovine virus analysis of which 20 were collected during low-flow periods and 43 were collected during rainfall or snowmelt runoff periods. Human viruses were present in 49% and bovine viruses were present in 41% of these samples (Fig. 4). Overall average concentrations were 56 genomic copies/L for the sum of human viruses and 1.2 genomic copies/L for the sum of bovine viruses.

3.1. Human viruses

3.1.1. Organisms

All six human viruses were detected at least one time. Adenovirus was present most often (40%) followed by GI norovirus (10%), enterovirus (8%), and rotavirus (6%). The greatest concentrations observed were for adenovirus (Cedar Creek and Milwaukee River), enterovirus (Cedar Creek), and GI norovirus (Milwaukee River) with concentrations exceeding 300 genomic copies/L (one sample each) all occurring in March 2007 during spring runoff events. GI norovirus (Cedar Creek, low-flow sample) and hepatitis A virus (Milwaukee River, runoff

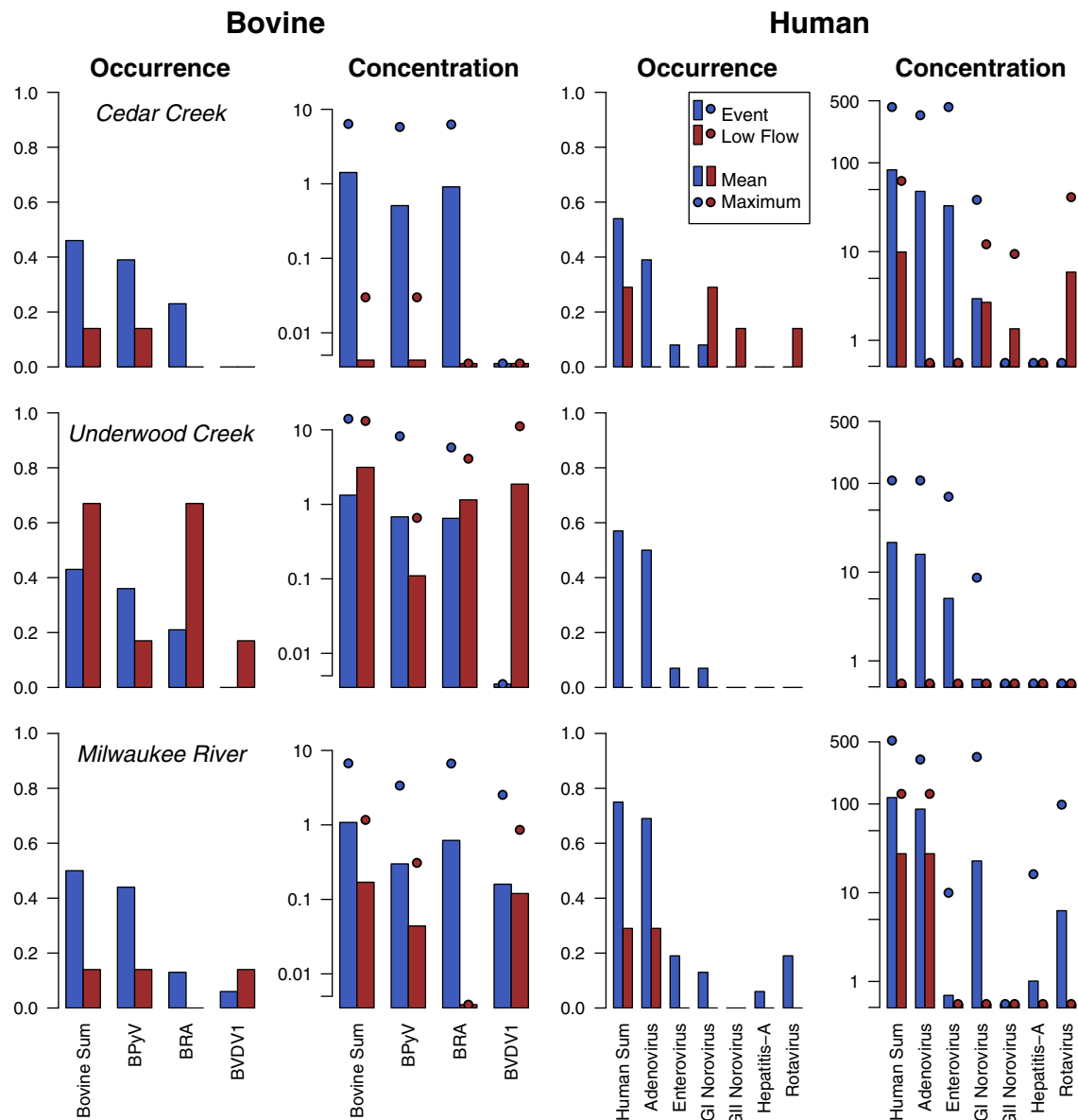

Fig. 4. Occurrence (fraction of samples that were virus positive), mean concentrations and maximum concentrations (genomic copies/L) of human and bovine viruses at three sites in the Milwaukee River watershed, Wisconsin from February 2007 to June 2008. BPvV represents bovine polyomavirus, BRA represents bovine rotavirus group A, BVDV1 represents bovine viral diarrhea virus type 1.

event sample) were each detected only one time during the study period.

3.1.2. Hydrologic condition

Human virus occurrence and mean concentrations in samples from all three sites were greater in runoff samples than in samples collected during low-flow periods (Fig. 4). Total concentrations (sum of all human viruses) averaged 76 genomic copies/L in runoff event samples and 13 genomic copies/L in low-flow samples. The difference in runoff event compared to low-flow occurrence was dominated by adenovirus and enterovirus occurrence. Occurrence of other viruses studied was not substantially different among the two hydrologic conditions. The average hourly loading (flux) of human-specific viruses from each site per unit area was greater during event periods than during low-flow periods ($p < 0.05$) at two of the three sites (Fig. 5). Flux during runoff events was greater at the Milwaukee River than other sites ($p < 0.05$), but there were no significant differences among sites during low-flow periods.

3.1.3. Season

Human virus occurrence through the study period was more prevalent in the cold-weather months from December–April (67%) than other months except for August 2007, which had 100% human virus occurrence in eight samples (Fig. 6). August human virus sample results, however, had relatively low concentrations (average = 10 genomic copies/L) compared to the cold-weather months sampled during the study period (average = 86 genomic copies/L). June was the only other month with relatively large human virus concentrations (average for 2007 and 2008 = 58 genomic copies/L). Samples were not collected in July and November.

3.1.4. Sampling locations

Comparing among monitoring locations, the Milwaukee River had greater overall human virus concentrations than Cedar and Underwood Creeks ($p < 0.05$). This pattern was true for runoff event samples and low-flow samples as well. The overall occurrence percentage of human viruses was slightly greater in the Milwaukee River (65%)

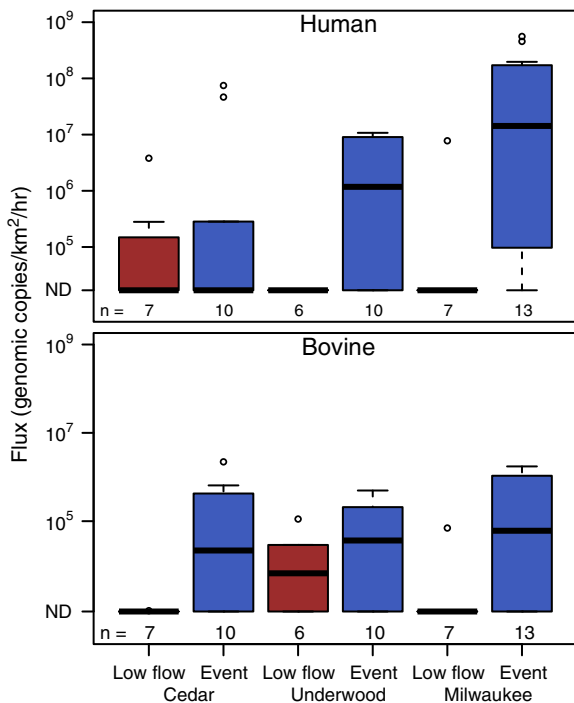

Fig. 5. Variability and magnitude in loadings of human and bovine viruses during event and low flow periods for the Milwaukee River watershed and two subwatersheds representing urban and agricultural land use. The box represents the 25th to 75th quantiles with a horizontal line for the median. The whiskers represent data beyond the box within 1.5 times the interquartile range. Circles are data points beyond the upper or lower limits of the whiskers. ND indicates no viruses detected.

followed by Cedar Creek (45%) and then Underwood Creek (40%). These differences were driven largely by a high percent occurrence of human viruses during runoff events in Milwaukee River samples and no occurrence during low-flow periods in Underwood Creek samples.

Serotype identification was conducted on the samples that were positive for human adenovirus (26 samples) and human enterovirus (5 samples). Four of these samples could not be definitively identified (three adenovirus and one enterovirus). Identified adenovirus serotypes included 2, 5, 6, 7, 40, and 41. Identified enterovirus serotypes included coxsackievirus B1 and B5, and echovirus 3. The most prevalent serotype was adenovirus type 41 (11 samples). All others had three or less occurrences. Adenovirus was detected in eight samples from Underwood Creek (types 2, 6, 7, and undetermined), in 14 samples from the Milwaukee River (types 2, 40, and 41), and in five samples from Cedar Creek (types 2, 6, and 41). Enteroviruses were detected in one sample from Underwood Creek (coxsackievirus B1), in three samples from Milwaukee River (coxsackievirus B5, echovirus 3) and in one sample from Cedar Creek (serotype undetermined).

Infectivity was also determined for those samples that were QPCR-positive for human adenovirus and human enterovirus. Six samples were shown to be infective, with five being infective for adenovirus (types 2, 6, 7, 40, and 41) and four for enterovirus (coxsackievirus B1 and B5 and echovirus 3). Three of these samples were from the Milwaukee River, two were from Underwood Creek, and one was from Cedar Creek. All of the samples determined to be infective were collected during runoff events from the months of March, April, June, and August. None of the samples with occurrence of human adenovirus and human enterovirus in low-flow samples were determined to be infective.

3.2. Bovine viruses

3.2.1. Organisms

Three of the seven bovine viruses analyzed were detected during the study period. Bovine polyomavirus was present most often (32%)

followed by bovine rotavirus group A (19%), and bovine viral diarrhea virus type 1 (5%). Maximum concentrations for these three viruses ranged from 6.7 to 11 genomic copies/L. Four of the seven bovine viruses analyzed in these 63 samples (bovine viral diarrhea virus type 2, coronavirus, enterovirus, adenovirus) were not detected.

3.2.2. Hydrologic condition

Bovine virus occurrence and mean concentrations at Cedar Creek and the Milwaukee River were greater during runoff periods than low-flow periods (Fig. 4). Total concentrations from these two sites (sum of all bovine viruses) averaged 1.2 genomic copies/L in runoff event samples and 0.09 genomic copies/L in low-flow samples. The difference in runoff event compared to low-flow occurrence for these two sites was dominated by bovine polyomavirus. Occurrence of other viruses studied was not substantially different among the two hydrologic conditions for these two sites. The combination of bovine polyomavirus and bovine rotavirus A contributed to the difference in concentrations between low-flow and runoff periods for these two sites. For Underwood Creek, occurrence was greater in samples collected during low-flow periods than runoff periods, but the sum of bovine virus concentrations were similar during the two hydrologic conditions with mean concentrations of 1.3 and 3.1 genomic copies/L for runoff events and low flow periods respectively. Occurrence level from Underwood Creek in low-flow samples was primarily driven by bovine rotavirus A which was present in 4 of 6 samples. The flux of bovine-specific viruses from each site per unit area was greater during event periods than during low-flow periods ($p < 0.05$, Fig. 5). Loadings of bovine viruses during low-flow periods were greater in Underwood Creek than in Cedar Creek and the Milwaukee River, and loadings were very similar among sites during runoff event periods.

3.2.3. Season

Bovine virus occurrence and concentrations varied somewhat between cold to warm weather months, but not as much as that for human viruses. Occurrence of bovine virus samples during cold weather months was 49% and during warm weather months was 30%. Concentrations of bovine virus samples collected during cold weather months averaged 4.8 genomic copies/L and during warm weather months averaged 1.7 genomic copies/L. The highest concentrations occurred in samples from December and January.

3.2.4. Sampling locations

Bovine virus concentrations at individual sites were not significantly different ($p > 0.05$) for the three sites when considering both hydrologic conditions together or when considering only runoff event samples. Low-flow concentrations at Underwood Creek were greater than the other two sites ($p < 0.05$), but considering that only 6 low-flow samples were collected at Underwood Creek and 7 at each of the other sites, it is difficult to make a conclusive statement of site-to-site variability based on these low-flow sample results. The percent occurrence during runoff events was very similar among sites, but Underwood Creek had greater occurrence during low-flow periods than the other sites.

3.3. Multivariate regression

The regression analysis identified variables that were valuable in describing variability of the sum of human viruses and the sum of all viruses, but not for the sum of bovine viruses. Variables that proved to be most valuable in describing variability of human viruses were maximum streamflow, a seasonal variable, and three rainfall-related variables (Table 2). Variables that were most valuable in describing variability of the sum of all viruses included hydrologic condition (event or low-flow) and a seasonal variable.

The modeling results can be used in two ways. First, direct prediction of the virus concentration category (not detected, detected at a low concentration, or detected at a high concentration), and second as an

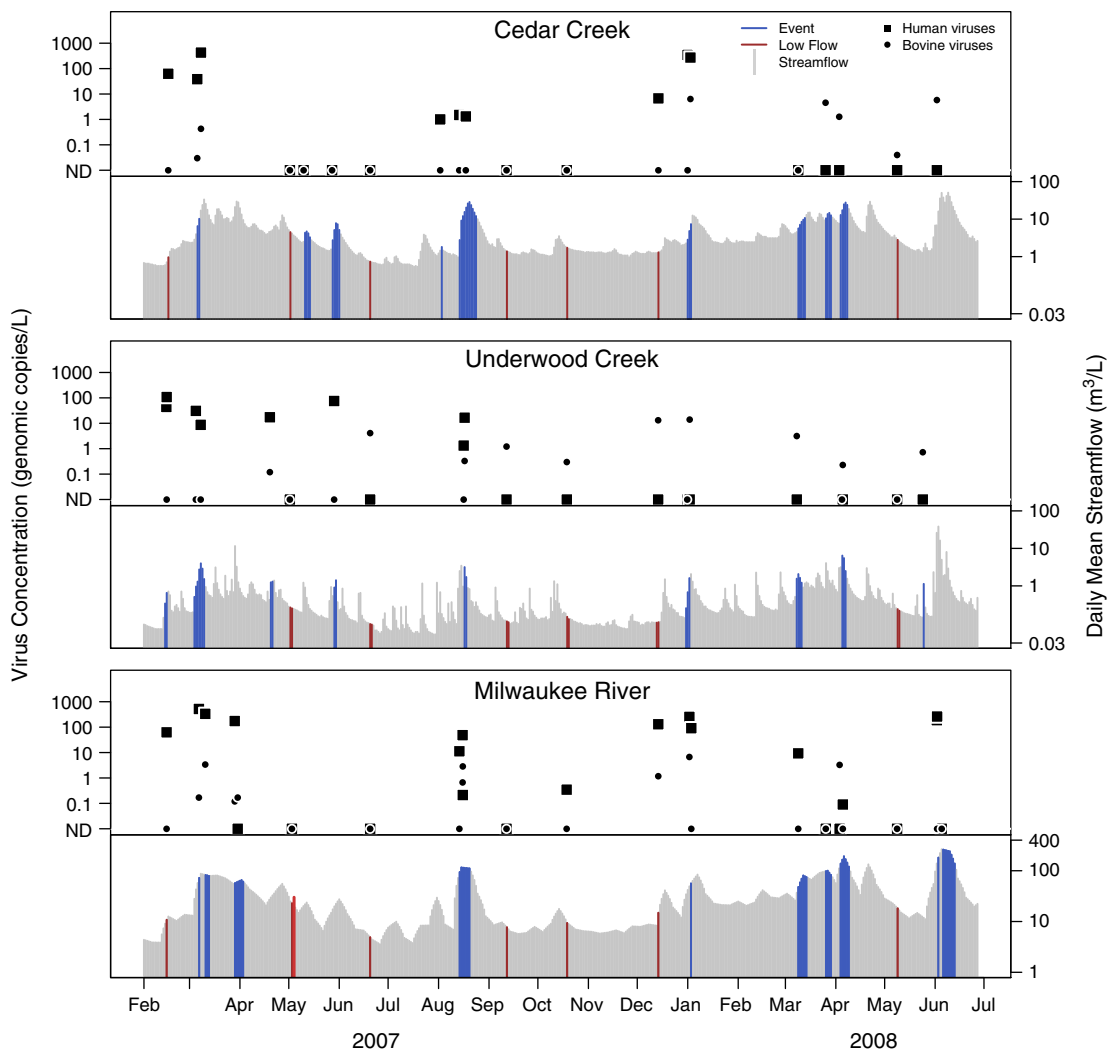

Fig. 6. Time series of human and bovine virus concentrations with streamflow for the Milwaukee River watershed and two subwatersheds representing urban and agricultural land use. Sampling periods are indicated by the width of red shading (low flow) and blue shading (runoff events) of the hydrographs. ND indicates no pathogens detected.

indication of virus occurrence by considering the second and third categories as one. In predicting the concentration category, the human virus model was correct for 72% and the model for all viruses was correct for 53% of the samples. In predicting the occurrence category (absent or present) using the same predictor variables as for concentration, the human virus model and the model for all viruses were correct for 75% and 83% of samples respectively.

Table 2
Predictors selected in multivariate regressions for pathogen concentrations in three Milwaukee, Wisconsin area streams, 2007–2008.

Pathogens	Predictor variables	Standardized coefficient
Human viruses	Maximum flow	7.60
	Cos(T) ^a	4.26
	Precipitation intensity	0.36
	3-day antecedent rainfall	0.006
	10-day antecedent rainfall	−0.002
Sum of human and bovine viruses	Event or low flow	3.75
	Cos(T)	2.00

^a Cos(T) = cosine($2\pi(\text{julian day} / 325.25)$) radians.

4. Discussion

Occurrence, concentration, and variability of human and bovine viruses were characterized in three streams over a 17-month period during low flow and increased runoff events using flow-weighted samples collected with custom-constructed automated samplers. Human enteric viruses are not uncommon contaminants in rivers located throughout the world and results from the present study for the Milwaukee River watershed proved to be no different. Forty nine percent of samples were human virus-positive. In comparison, reviewing more than two dozen published studies on human viruses in rivers, the occurrence rate typically reported for virus-positive samples was 30% to 80% (Kishida et al., 2012; Lee et al., 2013) and some studies report 100% of their river samples were virus positive. Samples from urban rivers in Barcelona, Spain and Rio Janeiro, Brazil (Calgua et al., 2013), the Ruhr and Rhine rivers in Germany (Hamza et al., 2009), and the Mille-Iles river in Quebec, Canada (Payment et al., 1988), were all positive for at least one type of human enteric virus; every sample of eight from the Maas and Waal rivers in the Netherlands contained four viruses: enterovirus, norovirus, reovirus, and rotavirus (Lodder and de Roda Husman, 2005). Virus concentrations in the rivers of the present study were on the order of tens to hundreds of genomic copies/L, at least two orders of magnitude lower than those measured in some other rivers. There

are many reports of adenovirus or norovirus concentrations in rivers of 10^4 genomic copies/L (Choi and Jiang, 2005; Hamza et al., 2009, 2011; Fong et al., 2010; Kishida et al., 2012; Calgua et al., 2013), which is only one or two orders of magnitude lower than virus concentrations found in wastewater treatment plant influent (Fong et al., 2010; Bradbury et al., 2013), suggesting that these rivers are highly polluted. The rivers sampled for the current study in the Milwaukee region might have less fecal pollution because of the substantial efforts in the region to minimize wastewater contamination by constructing a deep tunnel system for holding wastewater during combined sewer overflow events (Milwaukee Metropolitan Sewerage District). Another possible reason the Milwaukee River watershed virus concentrations were lower than previous studies is the sampling method. Previous studies on viruses in rivers used grab samples of various volumes, whereas the concentrations reported here are from flow-weighted samples collected over a minimum 24 hour period. This sampling method results in flow-weighted average concentrations while grab sampling could serendipitously reveal peak concentrations depending on the timing of sample collection.

Six samples from the Milwaukee River watershed were positive by cell culture for either or both adenovirus and enterovirus. Recent studies on viruses in rivers mostly rely on testing by PCR, only a few have tested for viruses by culture methods. Culturable viruses have been reported in 30% to 100% of samples from rivers in Japan (Tani et al., 1995), Korea (Lee et al., 2013), Quebec, Canada (Payment et al., 1988) and Michigan, USA (Jenkins et al., 2005). Choi and Jiang (2005) found that 16% of 114 samples from two rivers in southern California were positive for adenoviruses by qPCR with concentrations as high as 10^4 /L, yet none of these samples were culture positive on two cell lines, suggesting that the adenoviruses were inactivated. In the present study, culturable adenoviruses and enteroviruses were observed only during hydrologic events, never during low flow. This is likely due to increased sanitary sewer leakage or overflows during runoff events, but could also result from shorter transport time from contamination sources to sample location during runoff events allowing less time for inactivation by biotic and abiotic effects in the river.

While land use patterns differ among the drainage areas of the study rivers, all three are located in heavily populated southeastern Wisconsin where human fecal waste is treated by household septic systems or municipal sanitary sewer. Both treatment methods could be virus contamination sources because neither are 100% effective in removal. Conventional septic systems can release viruses to groundwater (Alhajjar et al., 1988; Scandura and Sobsey, 1997), whereupon they can be transported to groundwater gaining reaches of streams and rivers. Wastewater tertiary treatment, the level required for wastewater plants in the study area, provides only four or lower log removal of viruses, which may result in virus concentrations in the effluent on the order of 10^4 per liter (Myrmel et al., 2006; Fong et al., 2010) to be released at discharge pipes into rivers. Upstream from the sampling sites, wastewater effluent is discharged from one treatment plant on Cedar Creek and 14 small community plants discharge to the Milwaukee River. Although the Milwaukee River sampling site is located upstream from where the City of Milwaukee discharges effluent, the river occasionally reverses flow direction under the effects of the Lake Michigan seiche, possibly carrying Milwaukee effluent upstream to the sample site. Consistent with the number of wastewater inputs, the Milwaukee River did have the highest percentage of virus-positive samples.

Unlike Cedar Creek and the Milwaukee River, Underwood Creek does not have any septic systems or wastewater effluent discharge in its drainage area and yet 40% of the creek samples were human virus-positive. These viruses must have originated from the extensive sanitary sewer system within the urban basin. Sanitary sewers are known to leak outward (i.e., exfiltration) (Rutsch et al., 2006), and viruses released underground in untreated wastewater are capable of reaching groundwater and traveling long distances in short time periods (Hunt

et al., 2010, 2014; Bradbury et al., 2013). Two routes for exfiltrated sewage to contaminate rivers are possible, via groundwater flow to gaining river reaches or by infiltration into storm sewers that have river outfalls (Sercu et al., 2011). The latter route, particularly under wet conditions, would provide a rapid direct conduit to river waters. Sauer et al. (2011) investigated separated stormwater sewers (i.e., not combined with sanitary sewers) in the Milwaukee urban area and found that among 45 stormwater outfalls, all were positive at least once for human *Bacteroides*, suggesting that underground wastewater contamination from breaches in the sanitary sewer infrastructure was widespread and moving to stormwater sewers. Sercu et al. (2009) similarly used human *Bacteroides* to identify wastewater contamination of storm drains in Santa Barbara, CA, and in subsequent work in the same city used rhodamine dye tracer experiments to provide convincing evidence that sanitary sewers were, indeed, hydrologically connected to deeper storm drains (Sercu et al., 2011).

Bovine viruses detected in the present study (i.e., rotavirus, polyomavirus, and bovine viral diarrhea virus type 1) occurred at nearly the same frequency in the rivers as the human viruses, but their concentrations were nearly an order of magnitude lower. The difference in concentrations might be expected given the much higher population of humans compared to cattle in the river basins and that the sampling locations were far downstream of the most intensive agricultural areas, leaving time for settling or inactivation of bovine viruses before reaching the monitoring station. Four of the bovine viruses tested were undetected, probably because of low prevalence in the dairy herds in the basins. Measured at another time, the composition of bovine viruses in the rivers could be different.

In previous studies of rivers that had cattle in proximity, approximately 50% of river samples were positive for bovine viruses (Ley et al., 2002; Fong et al., 2005; Hundesa et al., 2006, 2010) except for a study on Maroochy River in Australia where only 10% of 40 samples were positive for bovine adenovirus (Ahmed et al., 2010). Consistent with these studies, bovine viruses were detected in the Milwaukee and Cedar rivers, where approximately 50% of the land use in the basins is agricultural, including dairy farming. However, bovine viruses were also present in Underwood Creek, a heavily urbanized river. The hydrologic patterns of bovine viruses in this river were also unusual in that the occurrence frequency and concentration decreased during runoff events, suggesting a contamination point source being diluted by the higher river discharges. One possible point source is the Milwaukee County Zoo, where cattle are housed and stormwater overland flow passing through animal pens could enter a tributary of Underwood Creek located on zoo property. Another source is a large meat packing plant that processes 1800 cattle per day. While not located in the creek basin, the plant's wastewater moves through the same sanitary sewer network serving the entire region, leaving open the possibility for bovine virus leakage via the same route as for human viruses. And lastly, it is possible that the bovine rotavirus A primers and probe amplified the bovine-origin VP1 gene of the human-bovine reassortant vaccine, RotaTeq (Matthijnssens et al., 2010), which was licensed in the US just as the present study began in 2006. As it is administered orally, the vaccine might have been present in Milwaukee wastewater. The vaccine is now widely administered in the US, limiting the value of bovine rotavirus VP1 as a target specific to a bovine source.

Among the many hydrometeorological variables examined in the present study, season, streamflow, and precipitation-related variables were positively associated with levels of human viruses and the combined sum of human and bovine viruses. Interestingly, antecedent rainfall, precipitation intensity, maximum streamflow, and season were also important predictors for high concentrations of *Cryptosporidium* in Cedar and Underwood Creeks (Corsi et al., 2003). Broadly speaking, that precipitation is related to river fecal contamination should not be surprising, knowing the myriad routes water takes to reach river ways and the opportunities these present to contact and carry fecal contamination: overland flow, groundwater flow, stormwater discharges,

combined and sanitary sewer overflow events, and sediment re-suspension. It is the specifics that are often lacking for modeling and predicting pathogen transport in watersheds (Ferguson et al., 2003).

The importance of precipitation and streamflow in the transport of protozoan and bacterial pathogens and fecal indicator bacteria in lotic systems has been frequently reported (Ferguson et al., 2003; Dorner et al., 2006; Wu et al., 2011; Duris et al., 2013), but only a handful of studies have related these environmental factors to virus transport and the findings have not been consistent. Rainfall or elevated river flow was associated with increased detection frequencies or increased virus concentrations at various sites in the area near Galveston, TX (Gerba et al., 1979), the Chicago area waterway system (Rijal et al., 2009), and the Atlamaha River, Georgia (Fong and Lipp, 2005). Rainfall did not increase virus levels in two rivers in southern California (Choi and Jiang, 2005), six river sites in Brisbane, Australia (Sidhu et al., 2012), and pathogen/virus levels even decreased during hydrologic events in the Grand River watershed, Ontario, Canada (Dorner et al., 2007). The reasons for this inconsistency are unknown; it could be related to site-specific factors such as hydromorphology, fecal contamination sources, and the epidemiology of viral infections at the times the studies were conducted. Another possibility is the variety of definitions by which the previous virus studies dealt with the precipitation predictor variables, primarily as a dichotomy (e.g., rainy season or dry season, rain or no rain, event or no event). For the present study, hourly radar-indicated precipitation data was available for each watershed and, adjusting for season, streamflow and precipitation-related variables were found to be the most important for describing variability of virus concentrations in the three study rivers. Perhaps as similarly specific data is measured in future studies, consistent patterns of precipitation effects on virus presence in rivers will emerge. For example, 10-day antecedent rainfall amount was negatively associated with human virus levels in the present study. Fong et al. (2005) observed a similar negative and significant association for human viruses and 30-day antecedent rainfall, suggesting that the association is not spurious and the mechanism should be identified and considered as future watershed models for viruses are developed.

The custom automated flow-weighted samplers are advantageous in being able to capture many events, regardless of the inconvenient times events happened. Another advantage is that the resulting data are flow-weighted average concentrations making it easy to compute accurate virus loading rates. Studies on pathogens and fecal indicator bacteria in rivers have typically relied on grab samples from which the resulting measured concentrations are multiplied by river discharge to calculate an instantaneous loading rate. Load can be better approximated from a load–duration curve derived from nearly continuous monitoring of discharge at a gauging station and more frequent grab samples (U.S. Environmental Protection Agency, 2001). For viruses, though, it is not practical to collect a sufficient number of grab samples for this approach; time constraints and cost of multiple samples per event are too limiting. If a sufficient number of grab samples are not collected, inaccuracies in load calculation are introduced by failing to account for streamflow-dependent changes in pathogen concentrations, that can vary substantially during an event hydrograph from rising limb to peak streamflow and recession (Krometis et al., 2007). The flow-weighted virus samplers avoided this problem. The primary disadvantage of this approach was that water quality data were collected at only three site locations; the samplers cannot be easily moved to alternative sampling locations. Resulting data represents all upstream processes influencing levels of viruses and other analytes, but without additional samplers, the variability in inputs and losses along discrete sections of the watershed length cannot be ascertained.

Similar to previous studies that have shown that bacterial loading rates in rivers increase during hydrologic events (Kistemann et al., 2002; Krometis et al., 2007), virus loading rates for the present study also increase with events, by two to three orders of magnitude compared to low flow conditions in two of the three study rivers. Such a

large difference suggests massive flushing of viruses from originating sources during events. A similar event effect, but not nearly of the same magnitude, was observed for bovine viruses in two of the three rivers. In contrast, for human viruses in Cedar Creek and bovine viruses in Underwood Creek, loading rates during low flow conditions were similar to loads during events, suggesting that in these rivers virus inputs were predominately more consistent sources. Identifying and mitigating virus inputs (i.e., fecal inputs) from these sources could quickly lead to water quality improvements in Cedar and Underwood Creeks during low flows.

Findings from the present study relating streamflow and precipitation to virus concentrations in Milwaukee-area rivers add further clarity to the emerging picture of the importance of the hydrologic cycle to pathogen transport and transmission of enteric infectious diseases. During periods of increased runoff when human virus concentrations become elevated in the Milwaukee River watershed, transmission could result from limited-contact recreational activities like wading, boating, and fishing. Participants in such activities in Chicago-area waters were found, using epidemiological methods, to have 46% to 50% increased risk for acute gastrointestinal illness (Dorevitch et al., 2012). In a similar study of recreational activities in the Chicago area waterway system using risk assessment methods, participants were at greatest risk for AGI recreating during wet weather (Rijal et al., 2009). Rivers are simply one link in the hydrologic cycle where pathogens can be measured and exposure can be assessed. During increased runoff periods in a heavily populated area with broad-scale movement of pathogens through the landscape, there may be other less obvious direct and indirect exposure routes that are responsible for a significant fraction of illness. In the Milwaukee area, Drayna et al. (2010) found that four days following rainfall of any amount, the number of children visiting a children's hospital emergency department for AGI treatment increased by 11%. Other studies have similarly linked heavy precipitation events with elevated AGI rates in Wisconsin (Uejio et al., 2014) and elsewhere (Curriero et al., 2001; Thomas et al., 2006). Recent downscaled climate models for the Milwaukee area predict that precipitation intensity and heavy precipitation events will increase to the point where daily rainfall depths of 7.6 and 10.2 cm occur twice as frequently by the mid 21st century as in the past (Vavrus and Behnke, 2013).

Given this scenario in Milwaukee and portended for other U.S. metropolitan areas as well, understanding transport of viruses and other enteric pathogens at the watershed scale will help identify where exposure can be prevented, sanitary infrastructure improved, and water treatment augmented to minimize precipitation-related enteric disease transmission.

Conflict of interest

The authors declare that there are no conflicts of interest.

Acknowledgment

Support for this research was provided by the Milwaukee Metropolitan Sewerage District (11E4WI24910031) and the U.S. Geological Survey. Thanks to Christopher Magruder from Milwaukee Metropolitan Sewerage District and Michelle Lutz and Jordan Gonnering in the U.S. Geological Survey, Cooperative Water Program for their contributions. Any use of trade, product, or firm names is for descriptive purposes only and does not imply endorsement by the U.S. Government.

Appendix A. Supplementary data

Supplementary data to this article can be found online at <http://dx.doi.org/10.1016/j.scitotenv.2014.05.072>.

References

- Abbaszadegan M, LeChevallier M, Gerba C. Occurrence of viruses in US groundwaters (PDF). *J Am Water Works Assoc* 2003;95(9):107–20. [Sep 1].
- Ahmed W, Goonetilleke A, Gardner T. Human and bovine adenoviruses for the detection of source-specific fecal pollution in coastal waters in Australia. *Water Res* 2010;44(16):4662–73. [Sep].
- Alhajar BJ, Stramer SL, Cliver DO, Harkin JM. Transport modelling of biological tracers from septic systems. *Water Res* 1988;22(7):907–15. [Jul].
- Aslan A, Xagorarakis I, Simmons FJ, Rose JB, Dorevitch S. Occurrence of adenovirus and other enteric viruses in limited-contact freshwater recreational areas and bathing waters: occurrence of adenovirus and other enteric viruses. *J Appl Microbiol* 2011;111(5):1250–61. [Nov].
- Borchardt MA, Bradbury KR, Alexander EC, Kolberg RJ, Alexander SC, Archer JR, et al. Norovirus outbreak caused by a new septic system in a dolomite aquifer. *Ground Water* 2011;49(1):85–97.
- Borchardt MA, Spencer SK, Kieke BA, Lambertini E, Loge FJ. Viruses in nondisinfected drinking water from municipal wells and community incidence of acute gastrointestinal illness. *Environ Health Perspect* 2012;120(9):1272–9. [Jun 1].
- Bosch A. Human enteric viruses in the water environment: a mini review. *Int Microbiol* 1998;1(3):191–6.
- Bradbury KR, Borchardt MA, Gotkowitz M, Spencer SK, Zhu J, Hunt RJ. Source and transport of human enteric viruses in deep municipal water supply wells. *Environ Sci Technol* 2013;47(9):4096–103. [May 7].
- Calgua B, Fumian T, Rusiñol M, Rodríguez-Manzano J, Mbayed VA, Bofill-Mas S, et al. Detection and quantification of classic and emerging viruses by skimmed-milk flocculation and PCR in river water from two geographical areas. *Water Res* 2013;47(8):2797–810. [May 15].
- Choi S, Jiang SC. Real-time pcr quantification of human adenoviruses in urban rivers indicates genome prevalence but low infectivity. *Appl Environ Microbiol* 2005;71(11):7426–33. [Nov 1].
- Corsi SR, Walker JF, Waschbusch RJ, Standridge J. Sources and variability of *Cryptosporidium* in the Milwaukee River. Report no.: 99-HHE-2. Alexandria, VA: Water Environment Research Foundation; 2003. p. 125.
- Curriero FC, Patz JA, Rose JB, Lele S. The association between extreme precipitation and waterborne disease outbreaks in the United States, 1948–1994. *J Inf [Internet]* 2001;91(8). [cited 2014 Feb 5]. Available from: <http://ajph.aphapublications.org/doi/abs/10.2105/AJPH.91.8.1194>.
- DeBorde DC, Woessner WW, Lauerma B, Ball PN. Virus occurrence and transport in a school septic system and unconfined aquifer. *Ground Water* 1998;36(5):825–34.
- Dorevitch S, Pratap P, Wroblewski M, Hryhorczuk DO, Li H, Liu LC, et al. Health risks of limited-contact water recreation. *Environ Health Perspect* 2012;120(2):192–7. [Feb].
- Dorner SM, Anderson WB, Slawson RM, Kouwen N, Huck PM. Hydrologic modeling of pathogen fate and transport. *Environ Sci Technol* 2006;40(15):4746–53.
- Dorner SM, Anderson WB, Gaulin T, Candon RM, Slawson RM, Payment P, et al. Pathogen and indicator variability in a heavily impacted watershed. *J Water Health* 2007;5(4):241–57. [Dec].
- Drayna P, McLellan SL, Simpson P, Li S-H, Gorelick MH. Association between rainfall and pediatric emergency department visits for acute gastrointestinal illness. *Environ Health Perspect* 2010;118(10):1439–43. [Oct].
- Duris JW, Reif AG, Krouse DA, Isaacs NM. Factors related to occurrence and distribution of selected bacterial and protozoan pathogens in Pennsylvania streams. *Water Res* 2013;47(1):300–14. [Jan 1].
- Ferguson C, Husman AMR, Altavilla N, Deere D, Ashbolt N. Fate and transport of surface water pathogens in watersheds. *Crit Rev Environ Sci Technol* 2003;33(3):299–361.
- Fong T-T, Lipp EK. Enteric viruses of humans and animals in aquatic environments: health risks, detection, and potential water quality assessment tools. *Microbiol Mol Biol Rev* 2005;69(2):357–71. [Jun 1].
- Fong T-T, Griffin DW, Lipp EK. Molecular assays for targeting human and bovine enteric viruses in coastal waters and their application for library-independent source tracking. *Appl Environ Microbiol* 2005;71(4):2070–8. [Apr 1].
- Fong T-T, Phanikumar MS, Xagorarakis I, Rose JB. Quantitative detection of human adenoviruses in wastewater and combined sewer overflows influencing a Michigan river. *Appl Environ Microbiol* 2010;76(3):715–23. [Feb 1].
- Fry J, Xian G, Jin S, Dewitz J, Homer C, Yang L, et al. Completion of the 2006 national land cover database for the conterminous United States. *Photogramm Eng Remote Sens* 2011;77(9):858–64.
- Gerba CP, Goyal SM, LaBelle RL, Cech I, Bodgan GF. Failure of indicator bacteria to reflect the occurrence of enteroviruses in marine waters. *Am J Public Health* 1979;69(11):1116–9. [Nov].
- Hamza IA, Jurzik L, Stang A, Sure K, Überla K, Wilhelm M. Detection of human viruses in rivers of a densely-populated area in Germany using a virus adsorption elution method optimized for PCR analyses. *Water Res* 2009;43(10):2657–68. [Jun].
- Hamza IA, Jurzik L, Überla K, Wilhelm M. Evaluation of pepper mild mottle virus, human picobirnavirus and Torque teno virus as indicators of fecal contamination in river water. *Water Res* 2011;45(3):1358–68. [Jan].
- Hundesa A, Maluquer de Motes C, Bofill-Mas S, Albinana-Gimenez N, Girones R. Identification of human and animal adenoviruses and polyomaviruses for determination of sources of fecal contamination in the environment. *Appl Environ Microbiol* 2006;72(12):7886–93. [Dec].
- Hundesa A, Bofill-Mas S, Maluquer de Motes C, Rodríguez-Manzano J, Bach A, Casas M, et al. Development of a quantitative PCR assay for the quantitation of bovine polyomavirus as a microbial source-tracking tool. *J Virol Methods* 2010;163(2):385–9. [Feb].
- Hunt RJ, Borchardt MA, Richards KD, Spencer SK. Assessment of sewer source contamination of drinking water wells using tracers and human enteric viruses. *Environ Sci Technol* 2010;44(20):7956–63. [Oct 15].
- Hunt RJ, Borchardt MA, Bradbury KR. Viruses as groundwater tracers: using ecohydrology to characterize short travel times in aquifers. *Groundwater* 2014;52(2):187–93. [Mar 1].
- Instituto Nacional de Estadística Geografía e Informática, The Atlas of Canada, U.S. Geological Survey. North American Atlas - Political Boundaries: Government of Canada, Ottawa, Ontario, Canada [Internet]. Instituto Nacional de Estadística, Geografía e Informática, Aguascalientes, Aguascalientes, Mexico;U.S. Geological Survey, Reston, Virginia, USA; 2006. Available from: <http://nationalatlas.gov/atlasftp-na.html>.
- Jenkins TM, Scott TM, Morgan MR, Rose JB. Occurrence of alternative fecal indicators and enteric viruses in Michigan Rivers. *J Great Lakes Res* 2005;31(1):22–31.
- Jiang SC, Chu W. PCR detection of pathogenic viruses in southern California urban rivers. *J Appl Microbiol* 2004;97(1):17–28.
- John DE, Rose JB. Review of factors affecting microbial survival in groundwater. *Environ Sci Technol* 2005;39(19):7345–56. [Oct].
- Kishida N, Morita H, Haramoto E, Asami M, Akiba M. One-year weekly survey of noroviruses and enteric adenoviruses in the Tone River water in Tokyo metropolitan area, Japan. *Water Res* 2012;46(9):2905–10. [Jun 1].
- Kistemann T, Claßen T, Koch C, Dangendorf F, Fischeher R, Gebel J, et al. Microbial load of drinking water reservoir tributaries during extreme rainfall and runoff. *Appl Environ Microbiol* 2002;68(5):2188–97. [May 1].
- Krometis L-AH, Characklis GW, Simmons III OD, Dilts MJ, Likirdopolos CA, Sobsey MD. Intra-storm variability in microbial partitioning and microbial loading rates. *Water Res* 2007;41(2):506–16. [Jan].
- Lambertini E, Spencer SK, Bertz PD, Loge FJ, Kieke BA, Borchardt MA. Concentration of enteroviruses, adenoviruses, and noroviruses from drinking water by use of glass wool filters. *Appl Environ Microbiol* 2008;74(10):2990–6. [May].
- Lee G-C, Jheong W-H, Kim M, Choi DH, Baik K-H. A 5-year survey (2007–2011) of enteric viruses in Korean aquatic environments and the use of coliforms as viral indicators. *Microbiol Immunol* 2013;57(1):46–53.
- Ley V, Higgins J, Fayer R. Bovine enteroviruses as indicators of fecal contamination. *Appl Environ Microbiol* 2002;68(7):3455–61. [Jul 1].
- Lodder WJ, de Roda Husman AM. Presence of noroviruses and other enteric viruses in sewage and surface waters in the Netherlands. *Appl Environ Microbiol* 2005;71(3):1453–61. [Mar 1].
- Matthijnssens J, Joelsson DB, Warakowski DJ, Zhou T, Mathis PK, van Maanen M-H, et al. Molecular and biological characterization of the 5 human-bovine rotavirus (WC3)-based reassortant strains of the pentavalent rotavirus vaccine, RotaTeq. *Virology* 2010;403(2):111–27. [Aug 1].
- Meixell BW, Borchardt MA, Spencer SK. Accumulation and inactivation of avian influenza virus by the filter-feeding invertebrate *Daphnia magna*. *Appl Environ Microbiol* 2013;79(23):7249–55. [Dec 1].
- Millen HT, Gonnering JC, Berg RK, Spencer SK, Jokela WE, Pearce JM, et al. Glass wool filters for concentrating waterborne viruses and agricultural zoonotic pathogens. *J Vis Exp Jove* 2012;61:e3930.
- Milwaukee Metropolitan Sewerage District. Milwaukee Metropolitan Sewerage District | Deep Tunnel. [Internet]. [cited 2014 Feb 5]. Available from: <http://www.mmsd.com/DeepTunnel.aspx>.
- Myrmel M, Rimstad E, Berg E, Grinde B. Enteric viruses in inlet and outlet samples from sewage treatment plants. *J Water Health* 2006;4:197–209. [Jan 1].
- National Atlas of the United States. National Atlas of the United States, county boundaries of the United States, 2001 [Internet]. Reston, VA: National Atlas of the United States; 2005 [Available from: <http://nationalatlas.gov/atlasftp.html>].
- Noble RT, Fuhrman JA. Enteroviruses detected by reverse transcriptase polymerase chain reaction from the coastal waters of Santa Monica Bay, California: low correlation to bacterial indicator levels. *Hydrobiologia* 2001;460(1–3):175–84.
- Payment P, Morin E, Trudel M. Coliphages and enteric viruses in the particulate phase of river water. *Can J Microbiol* 1988;34(7):907–10. [Jul 1].
- R. Development Core Team. R: a language and environment for statistical computing. [Internet]. Vienna, Austria. Available from: <http://www.R-project.org>, 2008.
- Rijal G, Petropoulou C, Tolson JK, DeFlaun M, Gerba C, Gore R, et al. Dry and wet weather microbial characterization of the Chicago area waterway system. *Water Sci Technol* 2009;60(7):1847. [Oct].
- Rutsch M, Rieckermann J, Krebs P. Quantification of sewer leakage: a review. *Water Sci Technol* 2006;54(6–7):135. [Oct].
- Rutsch M, Rieckermann J, Cullmann J, Ellis JB, Vollertsen J, Krebs P. Towards a better understanding of sewer exfiltration. *Water Res* 2008;42(10–11):2385–94. [May].
- Rzezutka A, Cook N. Survival of human enteric viruses in the environment and food. *FEMS Microbiol Rev* 2004;28(4):441–53. [Oct].
- Sauer EP, VandeWalle JL, Bootsma MJ, McLellan SL. Detection of the human specific *Bacteroides* genetic marker provides evidence of widespread sewage contamination of stormwater in the urban environment. *Water Res* 2011;45(14):4081–91. [Aug].
- Scandura JE, Sobsey MD. Viral and bacterial contamination of groundwater from on-site sewage treatment systems. *Water Sci Technol* 1997;35(11–12):141–6.
- Schijven JF, Hassanizadeh SM. Removal of viruses by soil passage: overview of modeling, processes, and parameters. *Crit Rev Environ Sci Technol* 2000;30(1):49–127. [Jan].
- Schwab DJ, Bedford KW. Great Lakes forecasting. In: Mooers C, editor. *Coast Ocean PredictAmer*. Geophys. Union Coastal and Estuarine Studies; 1999.
- Sercu B, Werfhorst LCV, Murray J, Holden PA. Storm drains are sources of human fecal pollution during dry weather in three urban southern California watersheds. *Environ Sci Technol* 2009;43(2):293–8. [Jan 15].
- Sercu B, Van De Werfhorst LC, Murray JLS, Holden PA. Sewage exfiltration as a source of storm drain contamination during dry weather in urban watersheds. *Environ Sci Technol* 2011;45(17):7151–7. [Sep 1].

- Sidhu JPS, Hodgers L, Ahmed W, Chong MN, Toze S. Prevalence of human pathogens and indicators in stormwater runoff in Brisbane, Australia. *Water Res* 2012;46(20):6652–60. [Dec 15].
- Southeastern Wisconsin Regional Planning Commission, Environmental Division, GIS Division. *SEWRPC digital watershed mapping; 2005* [Waukesha, Wisconsin].
- Tani N, Dohi Y, Kurumatani N, Yonemasu K. Seasonal distribution of adenoviruses, enteroviruses and reoviruses in urban river water. *Microbiol Immunol* 1995;39(8):577–80.
- Thomas KM, Charron DF, Waltner-Toews D, Schuster C, Maarouf AR, Holt JD. A role of high impact weather events in waterborne disease outbreaks in Canada, 1975–2001. *Int J Environ Health Res* 2006;16(3):167–80.
- U.S. Environmental Protection Agency. Protocol for developing pathogen TMDLs [Internet] Report no.: EPA 841-R-00-002. Washington D.C.: U.S. Environmental Protection Agency; 2001. p. 134 [Available from: http://www.epa.gov/owow/tmdl/pathogen_all.pdf].
- U.S. Environmental Protection Agency, U.S. Geological Survey. National hydrography dataset plus – NHDPlus, version 1 [Internet] Washington, D.C.: U.S. Environmental Protection Agency; 2005 [Available from: http://www.horizon-systems.com/NHDPlus/NHDPlusV1_data.php].
- Uejio CK, Yale SH, Malecki K, Borhardt MA, Anderson HA, Patz JA. Drinking Water Systems, Hydrology, and Childhood Gastrointestinal Illness in Central and Northern Wisconsin. *Am J Public Health*. 2014:e1–8.
- Vavrus SJ, Behnke RJ. A comparison of projected future precipitation in Wisconsin using global and downscaled climate model simulations: implications for public health. *Int J Climatol* 2013. [n/a-n/a].
- Venables WN, Ripley BD. *Modern applied statistics with S* [Internet] 4th ed. New York: Springer; 2002 [Available from: <http://www.stats.ox.ac.uk/pub/MASS4>].
- Wade TJ, Calderon RL, Sams E, Beach M, Brenner KP, Williams AH, et al. Rapidly measured indicators of recreational water quality are predictive of swimming-associated gastrointestinal illness. *Environ Health Perspect* 2006;114(1):24–8.
- Wisconsin Department of Natural Resources. Chapter nr113, servicing septic or holding tanks, pumping chambers, grease interceptors, seepage beds, seepage pits, seepage trenches, privies, or portable restrooms. *Wis Adm Code* [Internet] Madison, WI: Wisconsin Department of Natural Resources; 2002. Department of Natural Resources; 2001 [cited 2014 Apr 2]. p. 121-132. Available from: http://docs.legis.wisconsin.gov/code/admin_code/nr/100/113.pdf.
- Wade TJ, Calderon RL, Brenner KP, Sams E, Beach M, Haugland R, et al. High sensitivity of children to swimming-associated gastrointestinal illness: results using a rapid assay of recreational water quality. *Epidemiology (Cambridge, Mass.)* 2008;19(3):375–83.
- Wu J, Rees P, Dörner S. Variability of *E. coli* density and sources in an urban watershed. *J Water Health* 2011;9(1):94. [Mar].