

Available online at [www.sciencedirect.com](http://www.sciencedirect.com)**ScienceDirect**

Procedia Economics and Finance 35 (2016) 401 – 410

---



---

**Procedia**  
 Economics and Finance  

---



---

[www.elsevier.com/locate/procedia](http://www.elsevier.com/locate/procedia)

7th International Economics &amp; Business Management Conference, 5th &amp; 6th October 2015

## Factors Influencing Online Shopping Behavior: The Mediating Role of Purchase Intention

Yi Jin Lim<sup>a</sup>, Abdullah Osman<sup>b</sup>, Shahrul Nizam Salahuddin<sup>c\*</sup>, Abdul Rahim Romle<sup>d</sup>,  
Safizal Abdullah<sup>e</sup>

<sup>a</sup>College of Business, Universiti Utara Malaysia 06010 Sintok, Kedah, Malaysia

<sup>b</sup>Kulliyah Muamalat, Insaniah University College, 09300 Kuala Ketil, Kedah, Malaysia.

<sup>c</sup>College of Business, University Tenaga Nasional, 26700 Bandar Muadzam, Pahang

<sup>d</sup>College of Legal, Government & International Studies, Universiti Utara Malaysia 06010 Sintok, Kedah, Malaysia

<sup>e</sup>School of Business Innovation and Technopreneurship, Universiti Malaysia Perlis, 01000 Kangar, Perlis, Malaysia.

---

### Abstract

Internet shopping is a phenomena that is growing rapidly nowadays. A peep into the exponential growth of the main players in this industry indicates there is still a large reservoir of market potential for e-commerce. The conveniency of online shopping rendering it an emerging trend among consumers, especially the Gen Y. The prevalence of online shopping has raised the interest of the retailers to focus on this area. Therefore, this study was to determine the relationship between subjective norm, perceived usefulness and online shopping behavior while mediated by purchase intention. University students aged between 18 and 34 that currently pursuing their studies in University Malaysia Perlis were selected as the subject of analysis. 662 out of 800 sets of questionnaires distributed were valid for coding, analyzing and testing the hypothesis. Collected data were then analyzed using SPSS version 18.0 and AMOS version 16.0. Structural Equation Modeling to examine the model fits and hypothesis testing. The conclusion can be depicted that subjective norm and perceived usefulness significant positively influence online purchase intention but subjective norm insignificant influence shopping behavior in a negative way. It is interesting to note that perceived usefulness also insignificantly influence online shopping behavior. Finding also revealed that purchase intention significant positively influence online shopping behavior. For future research, sample from working adults and other variables that related to online shopping were to be included to minimise sampling bias.

© 2016 The Authors. Published by Elsevier B.V. This is an open access article under the CC BY-NC-ND license (<http://creativecommons.org/licenses/by-nc-nd/4.0/>).

Peer-reviewed under responsibility of Universiti Tenaga Nasional

**Keywords:** Subjective Norm; Perceived Usefulness; Purchase Intention; Online Shopping Behavior; University

---

\*Corresponding author. Tel: +609-4552020; fax: +609-4552006  
Email address: [ShahrulN@uniten.edu.my](mailto:ShahrulN@uniten.edu.my)

## 1. Introduction

Since its transition into a global interconnection network for sharing and delivering information, internet has emerged as a useful marketing tool to serve as a platforms for domestic and international transaction. According to A.T. Kearney (2015), retail e-commerce has grown nearly to US\$840 billions in 2014 surpassing the sales of US\$695 billions in year 2013 and it was estimated to increase to US\$1506 billions in 2018. The continuous sales increment indicated that e-commerce has enormous market potential. The operation and success of powerhouses such as Alibaba, Tenecent, Amazon and Groupon etc have set as a example for corporates to shift the model of their business from brick-and-mortar to brick-and-click. Regardless of the flourishing e-commerce on a global scale, Malaysia had dropped out from the 30<sup>th</sup> position in Top 30<sup>th</sup> Global Retail E-Commerce ranking in 2015 (A.T. Kearney, 2013). The slump in Malaysian spending capacity is consistent with the global financial crisis (Chen, Tan, & Chong, 2015; Ieconomics, 2015) . For a middle-income economies like Malaysia, it is reasonable for the citizens to curb their spending, especially when the Malaysian currency has confronted a steep fall since 2013 (Chew & Ng, 2013) . Yet, this condition is not upsetting few industries including online businesses and foreign direct investments into our countries. The global economy crisis could drive companies and entrepreneurs into online marketing as it is the cheapest way for advertising and reach out the vast custosmer base in short period of time (Business Insider, 2015). Masaya Ueno, the president and chief executive officer of Rakuten Online Shopping Malaysia regconised that online shopping is gaining its attention in Malaysia (The Star, 2014, March 29). It can be seen from the recent opened webstore such as 11street, a brand from South Korea which was deemed as the formidable intimidator in the already competitive market of domestic e-commerce in Malaysia (Law, 2015). Another local retailer that goes online this year is Atoz which sells electronic devices, stationeries, groceries and sundry goods (Atoz, 2015). As a matter of fact, e-commerce in Malaysia is still evolving from the current prototype and it is important to address the factors that influence online shopping behaviors. The changes of consumer behavior that over the decade has reined the retailers dig into the psychology of the virtual consumers. The difficulty of decoding the online consumer behavior is complicated by zero physical interaction during the transactions. (Jiang, Chen, & Wang, 2008; Mukherjee & Nath, 2007). Huge investment to grasp virtual consumers has induced the online sellers to go no further towards the understanding of consumer behavior. Although both government and private sectors have put in much efforts to prosper the virtual shopping platform, traditional store remains as the instinctive choice for majority of consumers. (Ramayah & Ignatius, 2005). A related study by IPSOS Open Thinking Exchange (2012) found that 56 percent of the respondents from 24 countries prefer to shop in a traditional store rather than an online store (Marketing Charts, 2012). Even in developed countries such as United States, out of 63 percent of the consumers would make a survey on the internet before proceed to purchase traditional consumer electronics online, but only half of the consumers will truly purchase online (NPD Group, 2011). The reluctance to change behavior and culture-bounded are the other factors that prevent Malaysian to embrace online shopping (Harn, Khatibi, & Ismail, 2006; Jamil & Mat, 2011). Hofstede (2012) claimed that Malaysia has a low score of 41 percent in pragmatism dimension indicating Malaysian has a normative culture. The consumers tend to listen to verbal recommendations from close families and relatives, friends or even media before making a shopping decision. Therefore, to change the Malaysian consumers' perception to e-store, online retailers need to maximize efforts in doing promotion and performing good customer services in order to raise their interest in online shopping. A study by Rakuten (2010) found that 71 percent of Malaysian online shoppers tend to regret their online purchases, 48 percent were dissatisfied due to mismatched expectations, 29 percent were disappointed with the poor product quality and 30 percent of Malaysians failed to complete their online purchases. The consumers also consider it a hassle when they faced difficulty to log in into the account, product information provided are limited and difficult to reach the online retailers by phone (Oracle, 2011). Online retailers need to design their website in such a way to make them user-friendly and actively manage the social media marketing to channel traffic to their online website. Rakuten (2010) stated that through learning to avoid the pitfall, online shopping experience could be more satisfying for Malaysian. To date, a study by Jamil and Mat (2011) found that there are only few studies conducted on online shopping behavior of consumers in Malaysia and a related study assent the authors that understanding towards online shopping in Malaysia is still lacking. Thus, this research is primarily to examine factors that could influence online shopping behavior in Malaysia.

## 2. Literature Review

### 2.1 Subjective Norm

Ajzen (1991) and Orapin (2009) advocated that external elements such as perceived social pressure may actually influence one's behavior. Previous studies on subjective norms focused on family Takaful scheme (Husin & Rahman, 2013), intention to work in older age (Lu, 2012), infused soft drinks (David, Tong, Yin, 2012), telepresence systems (Park, 2013), participation in online community (Zhou, 2011), online shopping (Al-Maghrabi, Dennis, & Halliday, 2011; Limayem et al., 2000; Jamil & Mat, 2011; Orapin, 2009; Tseng et al., 2011; Xie et al., 2011). The subjects of analysis of most researches focused on university students as respondents (David, Tong, Yin, 2012; Orapin, 2009; Zhou, 2011) and others on general public, including professional as the respondents (Al-Maghrabi et al., 2011; Husin & Rahman, 2013; Limayem et al., 2000; Lu, 2012; Jamil & Mat, 2011; Park, 2013; Tseng et al., 2011; Xie et al., 2011). There is no direct significant relationship between subjective norm and consumer behavior and it has been proven by Ajzen(1991) that personal considerations tend to overshadow the influence of subjective norm. Most of the studies on subjective norm are mediated by purchase intentions before performing actual buying (Choo, Chung & Pysarchik, 2004; Limayem et al., 2000; Jamil & Mat, 2011; Zhou, 2011). A related finding by Jamil and Mat (2011) proposed that subjective norm does not significantly influence actual buying through the internet but have a profound significant effect on online purchase intention. The results implied that families, friends and the media only have a minor influence on the actual internet purchasing. Subjective norm was the second most influential factors after perceived behavioral control to influence the purchase intention to shop online (Orapin, 2009). He et al. (2008) hypothesized that the recommendations by third parties (subjective norm) significantly impacted the purchase intention of the consumers. Most of the findings indicated that subjective norm does has a direct significant influence on purchase intention towards online shopping (Leeraphong & Mardjo, 2013; Jamil & Mat, 2011; Siti, Mohammed & Nik Kamariah, 2012; Xie et al., 2011). The conclusion is applicable to Malaysian since Malaysian is culture-bounded and averse to changes (Harn et al., 2006;Jamil & Mat, 2011).

### 2.2 Perceived Usefulness

Perceived usefulness is defined as the extent to which consumers feel the online website could add value and efficacy to them when performing online shopping (Hu et al., 2009; Lai & Wang, 2012). Perceived usefulness could also be defined from an individual's point of view that by using a system would improve task performance (Davis, 1989; Zhu, Lee, O'Neal & Chen, 2009; Liao et al., 2013). The perceived usefulness of the website usually depends on the efficiency of technological characteristics such as advanced search engines and the personal service provided by the service provider to consumers (Kim & Song, 2010). Various information and high quality goods' descriptions must be provided to the customers to help customers in making an well-informed decision. (Chen, Gillenson & Sherrell, 2002). Previous studies on perceived usefulness were mostly conducted in developing countries such as China (He et al., 2008; Hu et al., 2009; Lai & Wang, 2012; Liu et al., 2010; Xie et al., 2011; Zhao & Cao, 2012), Malaysia (Letchumanan & Muniandy, 2013; Yuliharsi et al., 2011) Vietnam (Nguyen & Barrett, 2006) and Iran (Aghdaie et al., 2011) while a minor percentage conducted in developed countries such as Taiwan (Liao et al., 2013), South Korea (Kim & Song, 2010; Seo, Kun & Dae, 2013) and Spain (Enrique, Carla, Joaquin & Silvia, 2008; Hernandez et al., 2011; Jose, Silvia, Carla & Joaquin, 2013). It is because developing countries are still at the infant stage of information technology compared to developed countries (Hana, Mike & Parvaneh, 2012). Previous studies on the correlation between perceived usefulness and consumer behaviors were conducted (Aghdaie et al., 2011; Hernandez et al., 2011; Ndubisi & Jantan, 2003). Hernandez et al. (2011) revealed that perceived usefulness has significant effect towards online shopping behavior in Spain but Aghdaie et al. (2011) suggested that perceived usefulness do not have significant effect on internet purchasing behavior in Iran. It could be due to different standpoints of respondent from developed and developing country regarding the perceived usefulness influence on their internet shopping behavior. Concerns of price, quality, durability and other product-related aspects are the main drivers of buying decision in developed countries but the considerations could be vary from the developing countries (Ahmed, 2012). Previous study in Malaysia found that perceived usefulness of a specific system will have a direct significant impact on its information system usage (Ndubisi & Jantan, 2003). According to Enrique et al. (2008), Kim & Song (2010) and Xie et al. (2011), perceived usefulness was proven to have significant impact on the intention to purchase via internet. A supported study by Kim & Song (2010) advocated that consumers expected to

receive useful information and to browse through merchandise conveniently for purchase. Otherwise, the online shoppers will shift to their competitors since there are many similar products on sale in other online store (Kim & Song, 2010). In short, perceived usefulness will influence consumers' intention to purchase in high risk condition (Xie et al., 2011).

### 2.3 *Purchase Intention and Consumer Behavior*

Ajzen (1991) suggested that intentions are presumed to be an indicator of to what extent people willing to approach certain behavior and how many attempts they are trying in order to perform certain behavior. According to the studies by He et al. (2008), lack of intention to purchase online is the main obstacle in the development of electronic commerce. The theory of planned behavior (TPB) applied on Thai consumers implied that the intention to shop online was most likely to be affected by perceived behavioral control and subjective norm, the sum of the attitudes from the people surrounding them (Orapin, 2009). Since these two factors can influence consumers' purchase intention, thus influencing their behavior towards online shopping and eventually lead to actual action (Orapin, 2009). The shopping intention as a substitute for purchasing behavior also needs to be explored. Although intention has been determined as a salient predictor of actual behavior to shop online (He et al., 2008; Orapin, 2009; Pavlou & Fygenson, 2006; Roca et al., 2009), it should be acknowledged that purchase intention does not translate into purchase action (Kim & Jones, 2009). Based on Technology Acceptance Model (TAM), perceived ease of use and perceived usefulness determined the online shoppers' decision after online behavioral intention sink in (Hu et al., 2009). An online website should understand the customers' purchasing behavior in order to build and maintain the good relationship with customers (Kim & Hong, 2010). Jamil and Mat (2011) proposed that purchase intention may have a positive influence on actual online purchasing and recommended to further investigate on the relationship between these two variables in future studies. Limayem et al. (2000) admonished researchers to investigate on the intention, assuming that behavior will automatically string along.

### 2.4 *Theory of Planned Behavior (TPB)*

The Theory of Planned Behavior (TPB) is the extension of the Theory of Reasoned Action (TRA) (Ajzen & Fishbein, 1980; Fishbein & Ajzen, 1975) due to the salient limitation in the previous theory in dealing with voluntary behavior while the latter theory proposed that behavior is not completely under control thus a voluntary action (Ajzen, 1991). TRA posited that a person's positive attitude together with the individuals' thought constituted to the behavioral intention of one person. Opposition to TRA, TPB model provide a better explanation of behavioral model that a person is assumed to perform certain behavior if that person has actual control over the behavior (Ajzen, 1991). Thus, when a person has a more favorable attitude and subjective norm, and with the acceleration of perceived behavioral control and intention, that particular person will perform the actual behavior (Ajzen, 1991; Caulfield, 2012). In TPB model, behavioral beliefs are expected to influence attitude, so as the effect of normative beliefs on the subjective norms while control beliefs constitute the foundation of behavioral control (Ajzen, 1991). Yet, the relationship between these variables remained ambiguous (Ajzen, 1991).

### 2.5 *Technology Acceptance Model (TAM)*

TAM is an adaption of the Theory of Reasoned Action (TRA) and was used to assess user's computer acceptance, which is measured by the intention and the influence of attitude, perceived usefulness, perceived ease of use toward the intention to use (Davis et al., 1989). The result showed that perceived usefulness strongly influenced intention to use but perceived ease of use only has a trivial effect on the intention to use. On the other hand, attitude partially mediated the effects of perceived usefulness and ease of use on intention to use (Davis et al., 1989). Since attitude did not play as an important determinant to influence the variables, TAM was then modified by removing the attitude variable found in TRA. The new TAM demonstrated the intention as a mediator to influence the relationship between perceived usefulness, perceived ease of use and usage behavior (Venkatesh & Davis, 2000). The result showed that perceived usefulness and perceived ease of use are determinant of intention to use. This was supported by several previous studies (Heijden et al., 2003; Kim & Hong, 2010; Kim & Song, 2010; Peng et al., 2008; Liu et al., 2010). A related study by Gong et al. (2013); Roca et al. (2009); Yunsiza (2007) found that perceived usefulness is an important determinant of intention to use, but perceived ease of use has an insignificant

influence on intention to use. Bagozzi (2007) urged that TAM model is not appropriate to investigate and explain usage behavior because perceived usefulness and perceived ease of use might not properly examine usage behavior. The supported study by Chuttur (2009) suggested that future research should investigate and develop new models that focus on the strengths of the TAM and abandon its weaknesses.

Based on the the previous studies, the hypothesis was then developed;

H1: Subjective norm significant positively influences online purchase intention.

H2: Subjective norm significant negatively influences online shopping behavior.

H3: Perceived usefulness significant positively influence online shopping intention.

H4: Perceived usefulness significant positively influence online shopping behavior.

H5: Online purchase intention significant positively influence online shopping behavior.

### 3. Research Methodology

The relationship of subjective norm, perceived usefulness and online shopping behavior while mediated by online shopping intention was investigated. The quantitative survey method was conducted by distributing the questionnaires to both the undergraduate and postgraduate students in one higher learning institution in Perlis, Malaysia. Close-ended questions with 7-point Likert type scale was used throughout the study. A multi-stage sampling method which combined both stratified and systematic sampling techniques was applied in this study. Pilot study was conducted by completion of questionnaire by 30 undergraduate students to test the reliability and validity of the study design. Subsequently, 800 questionnaires were distributed to the respondents and 662 questionnaires were collected, indicating 83% response rate. Then, the data was interpreted using analytical tools including SPSS and AMOS. The underpinning theory in this research is Theory of Planned Behavior (TPB). According to Taylor and Todd (1995), the modified model of the TPB has better interpretation ability compared to pure TPB and TRA models. Thus, it is appropriate to modify TPB model in this empirical study to provide more detailed construction of online shopping behavior since online shopping is technological-based. In order to improve the Theory of Planned Behavior (TPB) introduced by Ajzen, thus theoretical framework for this study was modified to suit the current study by addition of one variable (perceived usefulness) to the TPB model. According to Mathieson (1991) and Taylor and Todd (1995), TPB provided better assessment and specific information in comparison to TAM that provided very general information. It was supported by Legris, Ingham and Collette (2003) that TAM only interpreted about 40 percent of the system use. Furthermore, perceived ease of use in TAM is not suitable to be applied in the model since with more experience in internet usage, the influence of perceived ease of use on intention decreases and the evidence regarding perceived ease of use remained inconsistent (Al-Maghrabi et al., 2011). Therefore, the new theoretical framework is developed as shown in Figure 3.1.

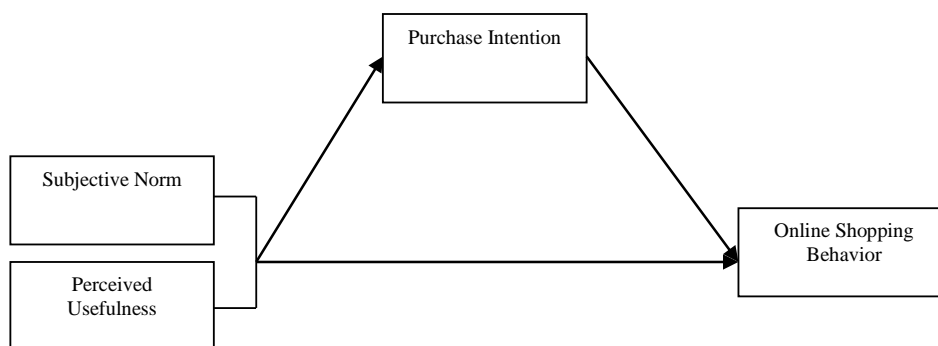

Fig 1. Theoretical Framework

## 4. Analysis and Findings

### 4.1 Pilot Study

Prior to questionnaire distribution, a pilot test for pre-testing purpose was conducted and distributed among 30 undergraduate students in University Malaysia Perlis. After granting permission from the lecturer, pilot test was conducted and a brief explanation regarding the research purpose was given in the class. The pilot test took about 25 minutes and all questionnaires were successfully collected. From the pilot study, all four variables (Subjective norm, perceived usefulness, purchase intention and online shopping behavior) have all above the good level of 0.80 as according to Sekaran (2003). No amendment had been made to the questionnaires and all items were remained as how it is being constructed.

### 4.2 Reliability Analysis

Table 1. Summary of Reliability Test

Variables	No. of Item	Cronbach's Alpha	Remarks
Subjective Norm	7	0.846	Good
Perceived Usefulness	8	0.939	Excellent
Purchase Intention	7	0.923	Excellent
Online Shopping Behavior	3	0.961	Excellent

From Table 1, since the Cronbach Alpha's value fall between 0.846 and 0.961, there are no items have been deleted as the values have fulfilled the requirement of over 0.70 as suggested Nunnally (1978). The internal consistency of all variables (subjective norm, perceived usefulness, purchase intention and online shopping behavior) indicated that all items remained good with the internal consistency of 0.846 while the variables with the highest reliability is online shopping behavior. Subsequently, all indicators were used for data collection.

### 4.3 Descriptive Analysis

Table 2. Summary of Descriptive Finding

Variables	N	Minimum	Maximum	Mean	Standard Deviation
Online Shopping Behavior	662	1.00	7.00	3.15	1.65
Online Purchase Intention	662	1.00	7.00	3.84	1.45
Subjective Norm	662	1.00	7.00	4.06	1.09
Perceived Usefulness	662	1.00	7.00	4.38	1.24

From Table 2, the mean scores are ranging from 3.00 to 5.00 indicated that all variables score moderate (Lopes, 2012). The lowest mean score of 3.15 goes to the dependent variable (online shopping behavior) and this showed that the respondents (university student) somewhat disagreed with the measurement. Perceived usefulness with the mean score of 4.38 showed the respondents neither agreed or disagreed with the indicator that represent perceived usefulness. The findings displayed acceptable variability within the data set as the standard deviation fell between 1.09 and 1.65. Thus, it shows that the respondents have different point of view regarding the studied variables.

### 4.4 Empirical Testing of Hypothesized Model

Since there were some value did not fulfilled the goodness of fit indices, a revised model was regenerated and some items have been deleted to improve the result based on the modification indices (MI) (Schumacker & Lomax, 2004). The revised model was subsequently displayed as below:

Table 3. Improvement of the Model

Model	Items	GFI	RMSEA	CFI	$\chi^2/DF$	TLI
1. Original Model	25	0.880	0.065	0.941	3.813	0.935
2. Revised Model	23	0.907	0.060	0.953	3.390	0.947

Based on Table 3, the total of 25 items have been reduced to 23 items to improve the overall fit. Subsequently,

the model indicated all of the requirements of goodness-of fit indices were achieved whereby the GFI was improved from 0.880 to 0.907 (> 0.90) as suggested by Hu & Bentler (1999), RMSEA from 0.065 to 0.060 ( $\geq 0.05$ ) (Kock, 2011), CFI from 0.941 to 0.953 (>0.95) (Kock, 2011), df/cmin from 3.813 to 3.390 ( $\geq 2 \leq 5$ ) (Marsh & Hocevar, 1985) and TLI from 0.935 to 0.947 ( $\geq 0.9$ ) (Vandenberg & Scarpello, 1994). The revised hypothesized model as showed in Figure 2 displayed that the dependent variable (online shopping behavior) were collectively explained 49% variance by the mediator (purchase intention) and independent variables (subjective norm and perceived usefulness). Subsequently, subjective norm and perceived usefulness jointly interpreted 51% variance of purchase intention.

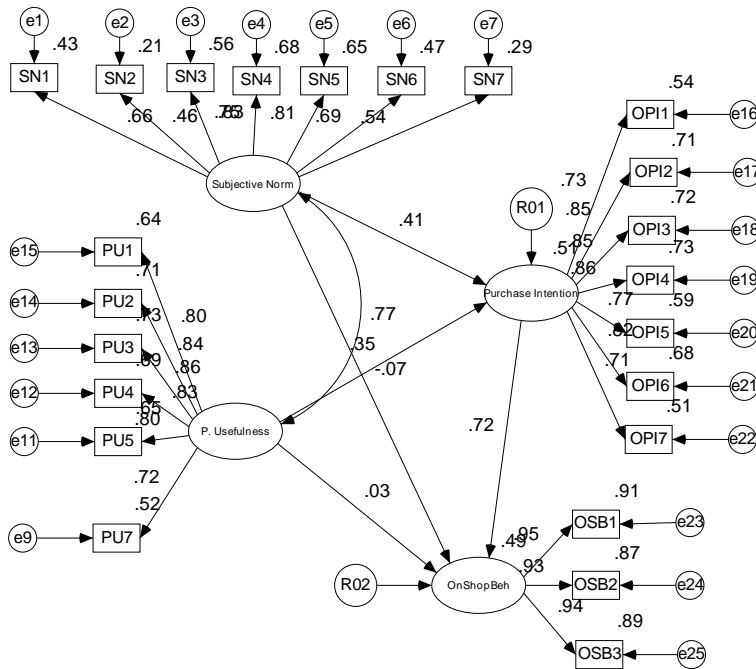

Fig 2. Revised Hypothesized Model

4.5 Hypothesis Testing Result of Direct Relationship of Variables

Hypotheses	Exogenous and Endogenous	Std. Estimate	Critical Ratio	Hypothesis
H1	SUB → PI	0.411	6.752***	Supported
H2	SUB → OS	-0.067	-1.121	Not Supported
H3	USE → PI	0.348	6.078***	Supported
H4	USE → OS	0.033	0.579	Not Supported
H5	PI → OS	0.723	13.301***	Supported

Table 4: Relationship between Exogenous and Endogenous Variable

The explanation of the hypothesized result was based on the revised model (Figure 2). According to Ghazali (2005), the path coefficient was significant at 0.05 level when the critical ratio was more than 1.96. Based on the table, hypothesis 1 was supported, whereby subjective norm significant positively influence online purchase intention ( $\beta = 0.411$ ) ( $p < 0.05$ ). Hypothesis 2 was not supported as the result showed insignificant results Hypothesis 4 was supported, indicating that perceived usefulness and purchase intention had moderate relationship. The relationship between perceived usefulness and online shopping behavior was very low positive relationship ( $\beta = 0.033$ ) and p-value more than 0.05, thus hypothesis 5 was rejected. Subsequently, hypothesis 7 was also supported and exhibited a very strong relationship ( $\beta = 0.723$ ) with the p-value less than 0.05.

## 5. Discussion and Conclusion

The findings showed three out of five hypotheses were supported. The connection between purchase intention and online shopping behavior showed the strongest relationship ( $\beta=0.723$ ,  $p<0.05$ ). The high effect of purchase intention towards online shopping behavior was consistent with previous studies (He et al., 2009; Orapin, 2009; Pavlou and Fyngenson, 2006; Roca et al., 2009) that the intention was a salient predictor of actual behavior to shop online. The second higher was between subjective norm and purchase intention with positive and significant result. The result implied that university students' purchase intention was influenced by perception of the families, friends and media. It was especially true when applied to Malaysians that culture-bounded and averse to change (Harn et al., 2006; Jamil & Mat, 2011). Hypothesis 3 was supported and in tandem with the findings from Enrique et al. (2008), Kim and Song (2010) and Xie et al. (2011). It is reasonable for the insignificant result between subjective norm and online shopping behavior as supported by Ajzen (1991) and Jamil and Mat (2011). Although perceived usefulness and online shopping behavior have weak positive relationship, the insignificant path was agreed by Aghdaie et al. (2011) and university students' actual online behavior tend to be more driven by other variables. This research has shown an increased explanatory power of the purchase intention and online shopping behavior compared to previous research. It also provides guideline for future research to concentrate on the strengths and terminate the weaknesses. As with any studies, there are some drawbacks in this research such as the sample chosen was limited to university students with higher education background. Thus, future study is suggested to select working adults and other variables that related to online shopping can be included.

## References

- A.T. Kearney., 2013. Online Retail is Front and Center in the Quest for Growth. Chicago: A.T. Kearney.
- A.T. Kearney., 2015. The 2015 Global Retail E-Commerce Index: Global Retail E-Commerce Keeps On Clicking. Chicago: A.T. Kearney.
- Aghdaie, S. F., Piraman, A., Fathi, S., 2011. An Analysis of Factors Affecting the Consumer's Attitude of Trust and their Impact on Internet Purchasing Behaviour. *International Journal of Business and Social Science*, 147-158.
- Ahmed, E.-K. (2012, November 1). 10 Consumer Behavior Differences between developed and developing Countries. Retrieved from We are development Website: <http://wearedevelopment.net/2011/11/01/10-consumer-behavior-differences-between-developed-and-developing-countries/>
- Ajzen, I., 1991. The Theory of Planned Behavior. *Organizational Behavior and Human Decision Processes*, 179 - 211.
- Ajzen, I., Fishbein, M., 1980. Understanding attitudes and predicting social behavior. Englewood Cliffs, NJ: Prentice.Hall.
- Al-maghrabi, T., Dennis, C., Halliday, S. V., 2011. Antecedents of Continuance Intentions towards e-shopping: the case of Saudi Arabia. *Journal of Enterprise Information Management*, 24(1), 85-111.
- Atoz., 2015. Atoz: It's just small thing, but we care. Retrieved June 21, 2015, from Atoz2u: <http://www.atoz2u.com/index.php?route=common/home>
- Bagozzi, R. P., Yi, Y., Phillips, L. W., 1991. Assessing Construct Validity in Organizational Research. *Administrative Science Quarterly*, 36(3), 421-458.
- Boundless., 2011. Attitude. Retrieved from Boundless Website: <https://www.boundless.com/marketing/consumer-marketing/personality-influences-on-the-consumer-buying-decision-process/attitude/>
- Business Insider. (2015, January 2). Why The Weakening Ringgit Is Not All Gloom and Doom. Retrieved June 21, 2015, from Business Insider: <http://www.businessinsider.my/why-the-weakening-ringgit-is-not-all-gloom-and-doom/#4boCLZDCior7Kkjo.97>
- Caulfield, B., 2012. The Theory of Planned Behaviour. Retrieved October 30, 2014, from A Trinity College Dublin Website: <http://www.tcd.ie/civileng/Staff/Brian.Caulfield/T2%20-%20Transport%20Modelling/The%20Theory%20of%20Planned%20Behaviour.pdf>
- Chen, C.-H., Zimitat, C., 2006. Understanding Taiwanese Students' Decision-making Factors regarding Australian International Higher Education. *International Journal of Educational Management*, 20(2), 91-100.
- Chen, L.-d., Gillenson, M. L., & Sherrell, D. L., 2002. Enticing Online Consumers: An Extended Technology Acceptance Perspective. *Information & Management*, 705-719.
- Chen, S., Tan, A., Chong, P. K. (2015, February 13). Pillar of Malaysia's Consumer Spending May Be Weakening. Retrieved June 21, 2015, from Bloomberg: <http://www.bloomberg.com/news/articles/2015-02-12/malaysia-spending-trackers-flash-reality-check-growth-warning>
- Chew, E., Ng, J. (2013, July 30). Malaysian Ringgit Slumps to 3-Year Low. Retrieved June 21, 2015, from The Wall Street Journal: <http://www.wsj.com/articles/SB10001424127887323854904578637444072954654>
- Choo, H., Chung, J.-E., Pysarchik, D. T., 2004. Antecedents to new food product purchasing behavior among innovator groups in India. *European Journal of Marketing*, 38(5/6), 608 - 625.
- Chuttur, M., 2009. Overview of the Technology Acceptance Model: Origins, developments and future directions. *Working Papers on Information Systems*, 9-37.
- Dabrowska, A., 2011. Consumer Behaviour in the Market of Catering Services in selected Countries of Central-Eastern Europe. *British Food Journal*, 113(1), 96-108.



- David, Y. K., Tong, X. F., Yin, E., 2012. Young consumers' views of infused soft drinks innovation. *Young Consumers*, 13(4), 392-406.
- Davis, F. D., 1989. Perceived Usefulness, Perceived Ease of Use, and User Acceptance of Information Technology. *Management Information Systems Quarterly*, 13(3), 319-340.
- Davis, F. D., Bagozzi, R. P., Warshaw, P. R., 1989. User acceptance of computer technology: A comparison of two theoretical models. *Management Science*, 35, 982-1003.
- Diallo, M. F., Chandon, J.-L., Cliquet, G., Philippe, J., 2013. Factors influencing Consumer Behaviour towards Store Brands: Evidence from the French Market. *International Journal of Retail & Distribution Management*, 41(6), 422-441.
- Enrique, B.-A., Carla, R.-M., Joaquin, A.-M., Silvia, S.-B., 2008. Influence of Online Shopping Information Dependency and Innovativeness on Internet Shopping Adoption. *Online Information Review*, 32(5), 648-667.
- Fishbein, M., Ajzen, I., 1975. *Belief, attitude, intention, and behavior: An introduction to theory and research*. Reading, MA: Addison-Wesley.
- Ghazali, I., 2005. *Model Persamaan Struktural - Konsep dan Aplikasi dengan Program AMOS Ver. 5.0*. Semarang, Indonesia: Badan Penerbitan Universitas Diponegoro.
- Gong, W., Stump, R. L., Maddox, L. M., 2013. Factors influencing consumers' online shopping in China. *Journal of Asia Business Studies*, 7(3), 214-230.
- Gunay, G. N., Baker, M. J., 2011. The factors influencing consumers' behaviour on wine consumption in the Turkish wine market. *EuroMed Journal of Business*, 6(3), 324-341.
- Hana, B.-S., Mike, M., Parvaneh, N., 2012. *E-Commerce is the Next Frontier in Global Expansion*. New York: AT Kearney. Retrieved from Arkearney website.
- Harn, A. C., Khatibi, A., Ismail, H., 2006. E-Commerce: A Study on Online Shopping in Malaysia. *Journal of Social Science*, 13(3), 231-242.
- He, D., Lu, Y., Zhou, D. (2008, June). Empirical Study of Consumers' Purchase Intentions in C2C Electronic Commerce. 13(3), 287-292.
- Heijden, H. v., Verhagen, T., & Creemers, M., 2003. Understanding Online Purchase Intentions: Contribution from Technology and Trust Perspectives. *European Journal of Information Systems*, 48.
- Hernandez, B., Jimenez, J., Martin, M. J., 2011. Age, gender and income: do they really moderate online shopping behaviour? *Online Information Review*, 36(1), 113-133.
- Hu, L.-t., Bentler, P. M., 1999. Cutoff criteria for fit indexes in covariance structure analysis: Conventional criteria versus new alternatives. *A Multidisciplinary Journal*, 6(1), 1-55.
- Hu, Y., Sun, X., Jing, Z., Zhang, X., Luo, F., Huang, L., 2009. A University Student Behavioral Intention Model of Online Shopping Based on TAM. *International Conference on Information Management, Innovation Management and Industrial Engineering* (pp. 625-628). IEEE Computer Society.
- Husin, M. M., Rahman, A. A., 2013. What drives Consumers to participate into Family Takaful Schemes? A Literature Review. *Journal of Islamic Marketing*, 4(3), 264-280.
- Ieconomics. (2015, June 21). *Malaysia Consumer Spending*. Retrieved June 21, 2015, from ieconomics: <http://ieconomics.com/malaysia-consumer-spending-forecast>
- Jamil, N. A., Mat, N. K., 2011. To Investigate The Drivers of Online Purchasing Behavioral In Malaysia Based on the Theory of Planned Behavior (TPB): A Structural Equation Modeling (SEM) Approach. *International Conference On Management*, (pp. 453-460).
- Jiang, J.-C., Chen, C.-A., Wang, C.-C., 2008. Knowledge and Trust in E-Consumers' Online Shopping Behavior. *International Symposium on electronic Commerce and Security* (pp. 652-656). IEEE Computer Society.
- Jose, M. P., Silvia, S.-B., Carla, R.-M., Joaquin, A.-M., 2013. Key factors of tennagers' mobile advertising acceptance. *Industrial Management & Data Systems*, 111(5), 732-749.
- Kim, E., Hong, T., 2010. Segmentating Customers in Online Stores from Factors that Affect the Customer's Intention to Purchase., (pp. 383-388).
- Kim, H., Song, J., 2010. The Quality of Word-of Mouth in the Online Shopping Mall. *Journal of Research in Interactive Marketing*, 4(4), 376-390.
- Kim, S., Jones, C., 2009. Online Shopping and Moderating Role of Offline Brand Trust. *International Journal of Direct Marketing*, 282-300.
- Kock, N. (2011). *E-Collaboration Technologies and Organizational Performance: Current and Future Trends*. Hershey: Information Science Reference.
- Koksal, M. H., 2007. Consumer Behaviour and Preferences regarding Children's Clothing in Turkey. *Journal of Fashion Marketing and Management*, 11(1), 69-81.
- Lai, E., Wang, Z., 2012. An Empirical Research on Factors Affecting Customer Purchasing Behavior Tendency During Online Shopping. (pp. 583-586). Institute of Electrical and Electronics Engineers.
- Law, J. (2015, April 25). 11street Officially Launches in Malaysia. Retrieved June 21, 2015, from hardwarezone: <http://www.hardwarezone.com.my/tech-news-11street-officially-launches-malaysia>
- Leeraphong, A., Mardjo, A. (2013, November). Trust and Risk in Purchase Intention through Online Social Network: A Focus Group Study of Facebook in Thailand. *Journal of Economics, Business and Management*, 1(4), 314-318.
- Legris, P., Ingham, J., Collette, P., 2003. Why do People use Information Technology? A Critical Review of the Technology Acceptance Model. *Information & Management*, 191-204.
- Letchumanan, M., Muniandy, B., 2013. Migrating to e-book: a study on perceived. *Library Hi Tech News*(7), 10-15.
- Liao, C., To, P.-L., Liu, C.-C., 2013. A Motivational Model of Blog Usage. *Online Information Review*, 37(4), 620-637.
- Limayem, M., Khalifa, M., Frini, A., 2000. What Makes Consumers Buy from Internet? A Longitudinal Study of Online Shopping. 421-432.
- Liu, Y., Chen, Y., Zhou, C. F., 2010. Determinants of Customer Purchase Intention in Electronic Service. Institute of Electrical and Electronics Engineers.
- Lopes, I. T., 2012. *Proceedings of the 7th European Conference on Innovation and Entrepreneurship (Vol. One)*. (C. Vivas, & F. Lucas, Eds.) Santarem: Academic Conferences Limited.
- Lu, L., 2012. Attitudes towards aging and older people's intentions to continue working: a Taiwanese study. *Career Development International*, 17(1), 83-98.
- Marsh, H.W., Hocevar, D., 1985. Application of confirmatory factor analysis to the study of self-concept: First- and higher order factor models and their invariance across groups. *Psychological Bulletin*, 97, 362-582.

- Marketing Charts., 2012. 6 in 10 Americans Prefer Shopping In Store to buying Online. MarketingCharts.
- Mathieson, K., 1991. Predicting user intentions: Comparing the Technology Acceptance Model with the Theory of Planned Behavior. *Information Systems Research*, 2(3), 173-191.
- Mukherjee, A., Nath, P., 2007. Role of Electronic Trust in Online Retailing: A Re-examination of the Commitment-Trust Theory. *European Journal of Marketing*, 41(9/10), 1173-1202.
- Ndubisi, N. O., Jantan, M., 2003. Evaluating IS Usage in Malaysian Small and Medium-sized Firms using the Technology Acceptance Model. *Logistic Information Management*, 16(6), 440-450.
- Nguyen, T. D., Barrett, N. J., 2006. The adoption of the internet by export firms in transitional markets. *Asia Pacific Journal of Marketing and Logistics*, 18(1), 29-42.
- Noor, N. A., Yap, S.-F., Liew, K.-H., Rajah, E., 2014. Consumer attitudes toward dietary supplements consumption: Implications for pharmaceutical marketing. *International Journal of Pharmaceutical and Healthcare Marketing*, 8(1), 6-26.
- Nordin, J. A., Nik Kamariah, M. N., 2011. To Investigate The Drivers of Online Purchasing Behavioral In Malaysia Based on the Theory of Planned Behavior (TPB): A Structural Equation Modeling (SEM) Approach. *International Conference On Management*, (pp. 453-460).
- NPD Group., 2011. *E-commerce and Consumer Electronics: Online Shopping and Purchasing"*. Washington: NPD Group.
- Nummally, J. C., 1978. *Psychometric Theory*. Michigan: McGraw-Hill.
- Oracle., 2011. *European Consumer Views of E-Commerce: A Consumer Research Study of Buying Behavior and Trends*. California: Oracle Corporation.
- Orapin, L., 2009. Factors influencing Internet Shopping Behavior: A Survey of Consumers in Thailand. *Journal of Fashion Marketing and Management*, 13(4), 501-513.
- Park, E., 2013. The adoption of tele-presence systems: Factors affecting intention to use tele-presence systems. *Kybernetes*, 42(6), 869-887.
- Pavlou, P. A., Fygenon, M. (2006, March). Understanding and Predicting Electronic Commerce Adoption: An Extension of The Theory of Planned Behavior. 30(1), 115-143.
- Peng, H., Wang, C., Cai, J., 2008. An empirical investigation on the adoption of online hopping of university students in China. *International Seminar on Business and Information Management* (pp. 498-501). Wuhan: Wuhan University.
- Rakuten., 2010. *Malaysian shoppers tend to regret their online purchases*. Tokyo: Rakuten Smart Shopping Survey.
- Raman, A., Annamalai, V., 2011. Web Services and e-Shopping Decision: A Study on Malaysian e-Consumer. *Wireless Information Networks & Business Information System*, 54-60.
- Ramayah, T., Ignatius, J., 2005. Impact of Perceived Usefulness, Perceived Ease of Use and Perceived Enjoyment on Intention to Shop Online. *Journal of Systems Management*, 1-16.
- Roca, J. C., Garcia, J. J., Vega, J. d., 2009. The Importance of Perceived Trust, Security and Privacy in Online Trading Systems. *Information Management and Computer Security*, 17(2), 96-113.
- Saylor., 2013. *Consumer Behavior: How People Make Buying Decisions*. Retrieved from Saylor Website: <http://www.saylor.org/site/wp-content/uploads/2013/02/BUS203-PoM-Ch3.pdf>
- Schumacker, R. E., Lomax, R. G., 2004. *A beginner's guide to structural equation modeling: Second Edition*. Mahwah, New Jersey: Lawrence Erlbaum Associates.
- Sekaran, U., 2003. *Research Methods for Business: A Skill Building Approach*, 4th edition. New Jersey: John Wiley & Sons.
- Seo, Y. W., Lee, K. C., Lee, D. S., 2013. The impact of ubiquitous decision support systems on decision quality through individual absorptive capacity and perceived usefulness. *Online Information Review*, 37(1), 101-113.
- Siti, O. N., Mohammed, A.-J. A., Nik Kamariah, N. M. (2012, June). Actual Online Shopping Behavior among Jordanian Customers. *American Journal of Economics*, 125-129.
- Taylor, S., Todd, P. A., 1995. Understanding Information Technology Usage: A Test of Competing Models. *Information Systems Research*, 6(2), 144-176.
- The Hofstede Centre., 2012. *What about Malaysia? The Hofstede Centre*.
- The Star. (2014, March 29). *Online shopping starts to gain more traction in Malaysia*. (Zieman, Ed.)
- Tseng, Y. F., Lee, T.-Z., Kao, S.-C., Wu, C., 2011. An extension of Trust and Privacy in the Initial Adoption of Online Shopping: An Empirical Study., (pp. 159-164).
- Vandenberg, R. J., Scarpello, V., 1994. A longitudinal assessment of the determinant relationship between employee commitments to the occupation and the organization. *Journal of Organizational Behavior*, 15(6), 535-547.
- Venkatesh, V., Davis, F.D., 2000. "A theoretical extension of the Technology Acceptance Model: Four Longitudinal Field Studies," *Management Science*, 46. 186-204.
- Xie, G., Zhu, J., Lu, Q., Xu, S., 2011. Influencing Factors of Consumer Intention towards Web Group Buying., (pp. 1397-1401).
- Yousaf, U., Altaf, M., Sarwar, N., Shah, S. A. (2012). Hesitancy Towards Online Shopping, A Study of Pakistani Consumers. *Journal of Management and Marketing*, 273-284.
- Yulihastri, Ku Amir, K. D., Md. Aminul, I. (2011, February). Factors that influence Customers' Buying Intention on Shopping Online. *International Journal of Marketing Studies*, 3(1), 128-139.
- Yusniza, K., 2007. Adoption of travel e-shopping in the UK. *International Journal of Retail & Distribution Management*, 35(9), 703-719.
- Zhao, Z., Cao, Q., 2012. An empirical study on continual usage intention of microblogging: the case of sina. *Nankai Business Review*, 3(4), 413-429.
- Zhou, T., 2011. Understanding online community user participation: a social influence perspective. *Internet Research*, 21(1), 67-81.
- Zhu, D.-S., Lee, Z.-C., O'Neal, G. S., Chen, Y.-H., 2009. The Effect of Trust and Perceived Risk on Consumers' Online Purchase Intention. *International Conference on Computational Science and Engineering*, (pp. 771-776).