

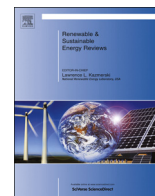

ELSEVIER

Contents lists available at ScienceDirect

## Renewable and Sustainable Energy Reviews

journal homepage: [www.elsevier.com/locate/rser](http://www.elsevier.com/locate/rser)

## Pre-processing of sugarcane bagasse for gasification in a downdraft biomass gasifier system: A comprehensive review

Anthony Anukam<sup>a,b,\*</sup>, Sampson Mamphweli<sup>a</sup>, Prashant Reddy<sup>c</sup>, Edson Meyer<sup>a</sup>, Omobola Okoh<sup>b</sup><sup>a</sup> Fort Hare Institute of Technology, University of Fort Hare, Private Bag X1314, Alice 5700, South Africa<sup>b</sup> Department of Chemistry, University of Fort Hare, Private Bag X1314, Alice 5700, South Africa<sup>c</sup> Department of Chemistry, Durban University of Technology, P.O. Box 1334, Durban 4000, South Africa

## ARTICLE INFO

## Article history:

Received 21 April 2015

Received in revised form

15 January 2016

Accepted 23 August 2016

Available online 1 September 2016

## Keywords:

Sugarcane bagasse

Biomass

Gasification

Pre-processing

Downdraft gasifier

Process efficiency

## ABSTRACT

The processing of sugarcane bagasse as a potential feedstock for efficient energy production has attracted a great deal of attention in the sugarcane industry, which has traditionally inefficiently burned bagasse in boilers for steam and electricity generation. Alternative technologies for more efficient utilisation of bagasse for energy production within the industry has also been hindered by the high degree of complexity involved in bagasse handling and pre-processing before it can be utilised as an energy feedstock. This can be attributed to unfavourable characteristics of mill-run bagasse, which includes low bulk and energy densities, a wide range of particle sizes and shapes as well as high moisture content. Gasification is regarded as one of the most promising energy recovery technologies for the widespread use of biomass because of its higher efficiency when compared to the combustion technology commonly used by the sugarcane industry. There has been a strong drive to identify efficient pre-processing methods that can be applied to bagasse to make it a suitable feedstock for energy production in thermochemical conversion systems. This work provides a comprehensive review on the pre-processing of bagasse for gasification, and the gasification technology options for its conversion into energy, with a particular emphasis on the downdraft gasification technology.

© 2016 The Authors. Published by Elsevier Ltd. This is an open access article under the CC BY-NC-ND license (<http://creativecommons.org/licenses/by-nc-nd/4.0/>).

## Contents

1. Introduction	776
2. Sugarcane bagasse generation and handling in South Africa	777
3. Sugarcane bagasse as an alternative energy resource	777
4. The composition and properties of sugarcane bagasse	778
4.1. Proximate and ultimate analysis of sugarcane bagasse	778
4.2. The heating value of sugarcane bagasse	778
4.3. The bulk density of sugarcane bagasse	779
4.4. Microstructure, macrostructure and chemical composition of sugarcane bagasse	779
5. Issues related to sugarcane bagasse utilisation	780
6. The pre-processing of sugarcane bagasse	781
7. The various pre-processing methods to improve bagasse quality	781
7.1. Densification	781
7.1.1. Pelletting	781
7.1.2. Briquetting	782
7.2. Comparison of different technologies used for densification	785
7.3. Densification systems process variables	785

Abbreviations: SCB, sugarcane bagasse; GHG, greenhouse gas; EOR, enhanced oil recovery; USDE, United States Department of Energy; USEPA, United States Environmental Protection Agency; SERI, Solar Energy Research Institute; NETL, National Energy Technology Laboratory; EBIA, European Biomass Industry Association

\* Corresponding author at: Fort Hare Institute of Technology, University of Fort Hare, Private Bag X1314, Alice 5700, South Africa.

E-mail address: [aanukam@ufh.ac.za](mailto:aanukam@ufh.ac.za) (A. Anukam).

<http://dx.doi.org/10.1016/j.rser.2016.08.046>

1364-0321/© 2016 The Authors. Published by Elsevier Ltd. This is an open access article under the CC BY-NC-ND license (<http://creativecommons.org/licenses/by-nc-nd/4.0/>).

7.3.1.	Pressure	786
7.3.2.	Temperature	786
7.3.3.	Die geometry and speed	786
7.3.4.	System retention time	786
7.4.	Torrefaction	787
7.5.	Drying and demoisturising	787
7.6.	Grinding	788
8.	The gasification process	788
8.1.	Drying zone	789
8.2.	Pyrolysis zone	790
8.3.	Oxidation zone	790
8.4.	Reduction zone	790
9.	Benefits of the gasification technology	790
9.1.	Efficiency benefits	790
9.2.	Environmental benefits	790
9.3.	Feedstock flexibility	791
9.4.	Product flexibility	791
9.5.	Carbon capture, storage and utilisation	791
10.	Types of gasification technologies	791
10.1.	The fixed-bed updraft or counter-current gasifier	791
10.2.	The fixed-bed downdraft or co-current gasifier	792
10.3.	The fixed-bed crossdraft gasifier	792
10.4.	The fluidised bed gasifier	793
10.5.	The entrained flow gasifier	793
10.6.	The plasma gasifier	794
11.	The choice of gasifier for sugarcane bagasse gasification	796
12.	Influence of gasifier design on the gasification process of sugarcane bagasse	796
13.	The chemistry of sugarcane bagasse gasification	796
14.	Summary	797
15.	Conclusions	797
	Acknowledgements	799
	References	799

## 1. Introduction

Sugarcane bagasse (SCB) is the fibrous residue obtained after the extraction of the sucrose-rich juice from sugarcane stalks. The various uses of SCB have been widely reported in the literature, and these include the manufacture of pulp and paper, animal feed, furfural, and other value added products [1,2]. However, these are limited markets which are also highly competitive. SCB has been considered as an agricultural biomass residue of great importance as a fuel for the sustainable production of electricity [1,3]. In the past, excess SCB was burned as a means of solid waste disposal, but as the cost of auxiliary fuels increased, the need to derive greater energy from all the SCB available to the factory became imperative. Currently in countries like South Africa, bagasse is used as a convenient fuel for the sugarcane industry but through inefficient combustion processes. This inefficient usage necessitates that in some instances supplementary fuels such as coal be used in significant amounts during factory operations. Consequently, for the industry to produce more energy from available SCB and offset the use of costly or non-renewable energy sources, more cost-effective and efficient technologies are required.

The application of SCB for optimal energy production requires an understanding of its composition, for which many studies have been performed. Mill-run bagasse contains approximately 50% fibre, 48% moisture and about 2% sugar [4–7]. This composition makes SCB an ideal material for energy production, however, its efficient utilisation for energy production in thermochemical conversion systems has been impeded by a number of factors, one of which is its handling and pre-processing which must be consistent with the energy conversion system that it is used in. There are various pre-processing methods that are available for biomass; however, there seem not to be a universal method or technology

pathway which is most appropriate for all types of biomass including SCB. There are a number of required characteristics for a pre-processing method to be considered industrially viable. These characteristics include the requirement that the pre-processing method should result in minimum degradation with maximum component recovery; it should have a low energy demand or be conducted in a way that the energy can be re-used in other process steps as secondary heat; and, it should have low capital and operational costs [8,9]. The use of physical methods for pre-processing can be considered as meeting all of these requirements. Pre-processing of SCB is intended to overcome inherent issues related to the disperse nature of bagasse, its high moisture and inorganic contents as well as its low energy and bulk densities. These shortcomings limit the widespread deployment of the thermochemical conversion systems using bagasse as feedstock for energy production purposes, rendering these systems unattractive. However, the complexity of SCB (in chemical composition and heterogeneity) is so high that its use as an energy feedstock requires further research and development to better understand the exact pre-processing and thermal conversion system parameters with respect to the polymeric structure and mineral composition of the material. One of the thermochemical conversion pathways by which SCB can be converted into energy is through gasification, which is a thermal devolatilisation process that breaks down any carbon-based material into its basic chemical constituents [10]. The process is based on a series of complex reactions that are influenced by many factors including the composition of the feed material to be converted, the pre-processing conditions of the feed and the operating conditions of the gasifier [11]. The feedstocks required for gasification, the advantages and disadvantages of the gasification technology as an energy production process are detailed later in Section 9 of this review.

This work therefore provides a comprehensive review of the pre-processing methods (with emphasis on the physical method of pre-processing) that can be applied on SCB to increase its value as a feedstock for the purpose of gasification in a downdraft biomass gasifier system. The idea is to identify and recommend the best pre-processing method for sugarcane bagasse after careful review of the various pre-processing methods. A description of the generation and current use of SCB and its handling including issues related to its efficient utilisation and the quality attributes of a pre-processed SCB are painstakingly described. The composition and properties of bagasse in relation to gasification are also discussed together with the possible effects of pre-processing not just on chemical and structural transformation of SCB, but also on gasification process efficiency. The pre-processing methods that are better suited for the purpose of gasification are also highlighted and described together with a review of the various gasification technologies including a comparison of the advantages and disadvantages of each gasification technology as well as the most suitable gasification technology for SCB conversion based on low cost, simplicity, ease of operation and efficiency.

## 2. Sugarcane bagasse generation and handling in South Africa

A surplus amount of SCB is generated in South Africa (about 3.3 million tons of raw bagasse is generated per annum) [12]. On average, about 30 t of wet (about 50% moisture) SCB is produced per 100 t of cane crushed per annum, and approximately 150 t of dry bagasse per 100 t of cane crushed is also produced per annum; so for every 3 kg of cane crushed, 1 kg of bagasse is produced, an amount could generate about 124 t/h of heat in the form of process steam to the mill, and about 56 MWe of electricity (10 MWe to be used by the sugar mill itself and 46 MWe by the rest of the community where the mill is located) [13–15]. Notwithstanding, SCB handling begins with the harvesting of the sugarcane crop from the growing fields before it is being transported to the sugar factory where it is crushed to extract the sucrose-rich juice [16]. After sucrose extraction, the resultant fibre (bagasse) is either immediately used as fuel in boilers or is stored for future use. Storage could be either in open heaps or in the form of bales. The process of handling the sugarcane fibre before and after processing the cane could result in the introduction of extraneous substances (foreign debris) that could appear as impurities, which could further reduce the value of SCB as a fuel for energy production as well as damage energy conversion systems including releasing harmful chemicals when bagasse is combusted [3]. Therefore, handling methods of SCB coupled with its low energy and bulk densities as well as its heterogeneous size and shape make it necessary for systems using bagasse as feedstock for energy production

purposes to undertake efficient pre-processing of the material to make it suitable for the energy conversion systems. As excess bagasse is generated during sugar processing, the sugar industry boilers are basically operated inefficiently to also dispose of the excess bagasse since there must be a balance between bagasse production and utilisation [17]. Fig. 1 shows a simplified SCB generation process diagram.

## 3. Sugarcane bagasse as an alternative energy resource

The selection of feedstock for energy production purposes is dependent upon certain criteria such as potential yield per hectare, feedstock properties and the potential uses [18]. SCB was chosen for this review because of its potential availability in excess of its usage as well as because of the fact that its use as a potential feedstock for efficient energy production has not been fully explored. However, the value of SCB as a fuel for energy production largely depends on its calorific value, which in turn depends on its composition, especially with regard to its moisture content and to the calorific value of the sugarcane plant, which mainly depends on its content of sucrose [19]. In sugar mills, bagasse is usually combusted in furnaces for steam production, and the steam in turn is used for power generation; but the challenge of this process is related to the net electrical efficiency, which is extremely low (between 10–20%) when compared with the gasification process, which can have an efficiency as high as 67–80% [20,21]. Another limitation of the use of the boiler technology for bagasse combustion is the duration of startup, which is usually up to 8 h as well as the use of auxiliary fuels as startup fuels, which results in SO<sub>2</sub> and NO<sub>x</sub> emissions including particulate emissions due to poor conditions of combustion in the boiler while it is cold during the startup period [21]. There are several pathways by which SCB can be converted into energy and some of those pathways include gasification, pyrolysis, liquefaction, fractionation, fermentation and hydrolysis [8]. However, the main focus of this review is on the pre-processing of SCB for the purpose of gasification, taking into account the quality of the pre-processed bagasse and its possible effects on gasification output parameters such as efficiency of the process and product gas yield.

Knowing the basic characteristics of biomass is key to successful operation of the energy conversion system using the biomass as feedstock [3]. The following section therefore details the composition and properties of SCB and their impact on gasification.

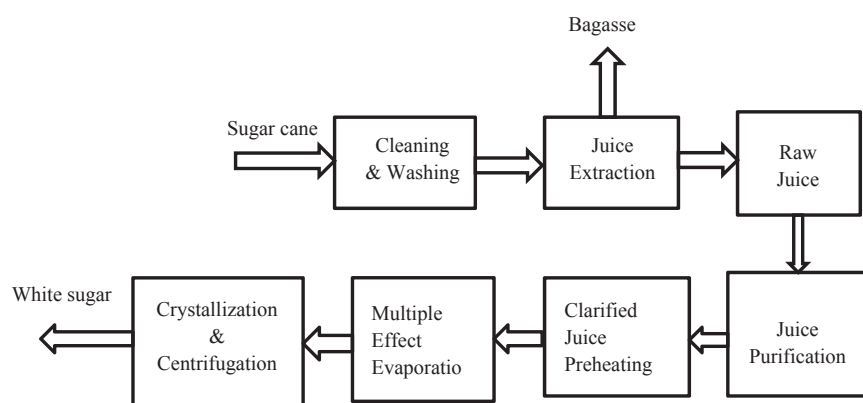

Fig. 1. A simplified process diagram for the generation of sugarcane bagasse [16].

#### 4. The composition and properties of sugarcane bagasse

The composition and the inherent properties of the source of biomass determine both the choice of the conversion process and any subsequent processing challenges that may arise, as the biomass choice is equally influenced by the form in which the energy is required, with the interplay between these two aspects enabling the introduction of flexibility into the application of biomass as an energy source [5]. The following sub-sections also presents and focuses on relevant properties and composition of SCB and their effect on gasification process efficiency based on studies conducted by previous authors.

##### 4.1. Proximate and ultimate analysis of sugarcane bagasse

The composition and properties of biomass can be described in terms of proximate and ultimate analyses, which are normally the first steps taken to evaluate the suitability of any biomass material for conversion into energy [22]. Proximate analysis provides the fuel properties in terms of the weight percentages of moisture, volatile matter and fixed carbon as well as ash content of the material. It is performed by heating the material to a set temperature, resulting in the decomposition of the material at that temperature to generate volatile substances. The volatile substances released from the decomposition reactions contain a series of gaseous molecules of CO, H<sub>2</sub> and CO<sub>2</sub> together with other hydrocarbons. The rate of decomposition and the released gas composition is dependent upon temperature and the heating rate of the decomposition reaction [22]. Pyrolysis or devolatilisation are terms used to describe these decomposition reactions. The moisture content of the biomass is the amount of water molecules that bond physio-chemically to the material, and can be removed by heating without the occurrence of chemical reactions in the process. Char is obtained as the left-over from the devolatilisation process of the biomass, and consists of fixed carbon and ash [22]. The proximate analysis data of SCB are listed in Table 1.

The data in Table 1 shows the extent of variation in the composition of SCB, which can be attributed to a number of factors including the source of the bagasse, the variety of the sugarcane crop and the growing conditions of the sugarcane including soil texture and composition where the cane was grown as well as weather and other conditions [3]. Although there is no significant variation in the composition of bagasse from Table 1, but it can also be clearly seen that SCB generally contain more volatile matter, which results in a lower char yield when bagasse is combusted or gasified. The moisture content varies depending on the source of the bagasse and specific handling conditions; however it is generally low because it is often air-dried from initial moisture content that is normally close to or above 50% as received before utilisation [23]. Generally, the proximate analysis of biomass provides a measure of the ease with which the biomass can be ignited and subsequently gasified or oxidised, depending on how the material is to be utilised as a source of energy [23]. However, pre-processing before conversion is intended to lower moisture content by drying, hence the low moisture contents reported in

**Table 1**  
Typical proximate analysis data of sugarcane bagasse (dry basis).

Proximate analysis (wt%)				
Moisture	Volatile matter	Fixed carbon	Ash	Reference
1.14	69.99	16.39	1.42	[23]
9.51	74.98	13.57	1.94	[24]
Not reported	84.83	13.28	1.89	[25]
Not reported	75.80	20.11	4.21	[26]

**Table 2**  
Typical ultimate analysis data of sugarcane bagasse (dry ash free basis).

Ultimate analysis (wt%)					
C	H	O	N	S	Reference
44.1	5.7	47.7	0.20	2.30	[23]
43.77	6.83	47.46	Not reported	Not reported	[24]
56.32	7.82	27.54	0.89	Not reported	[25]
44.1	5.26	44.4	0.19	Not reported	[26]

Table 1 by the first two authors.

Pre-processing of SCB has significant effects on all downstream processes and would ultimately influence the overall yield of the gasification process and cost [27]. As opposed to proximate analysis, ultimate analysis provides the elemental composition of biomass. It is performed by the complete combustion of a fuel, with the composition of the final products of combustion analysed and the main elements of the solid biomass determined. The ultimate analysis results of SCB from previous studies are also presented in Table 2.

It is evident from Table 2 that the main elemental constituents of SCB are C and O<sub>2</sub> with a negligible amount of H<sub>2</sub>. During gasification, H<sub>2</sub> plays a role in the final product gas composition due to its impact in the water-gas shift reaction discussed later in Section 13 (Table 6) of this review [28]. The high O<sub>2</sub> composition is due to the alcohol (OH) and carboxylic acid (COOH) groups in the main constituents of bagasse which are cellulose, hemicellulose and lignin, and which also accounts for the high reactivity and high ignition stability of SCB when used as fuel in thermochemical conversion systems such as the gasification systems [29]. However, the difficulties in using biomass materials such as SCB as fuel for energy production relates to its content of inorganic constituents, as some types of biomass may contain significant amounts of Cl, K and S in the salts of these elements (KCl and K<sub>2</sub>SO<sub>4</sub>) which are quite volatile. Their release may lead to large amounts of deposition on heat transfer surfaces, resulting in decreased heat transfer and enhanced rates of corrosion [30]. Unscheduled plant shutdown may be experienced due to severe deposits, and significant amounts of aerosols as well as relatively high emissions of HCl and SO<sub>2</sub>, which may also be generated due to the release of Cl, alkali metals and S in the gas-phase [30]. The metal/inorganic elements of bagasse are not given in Table 2 but can be determined from other analyses such as ash analysis.

##### 4.2. The heating value of sugarcane bagasse

The conversion process of SCB or any biomass material begins with the knowledge of the energy content of the biomass, measured in the units of MJ/kg [31]. The thermal conversion of biomass in the presence of excess amounts of air to release energy in the form of heat is termed its heating value or calorific value. This is usually measured using a bomb calorimeter; however in the absence of equipment for measuring the heating value of biomass, two common equations are used to estimate this value. These are the Dulong equation and the Boie equation [32,33]. The Dulong equation can be written as follows [31,32]:

$$HV(\text{MJ/kg})=33,823 \times C + 144,250 \left( \frac{H-O}{8} \right) + 9419 \times S \quad (1)$$

where HV is the heating value of the material in MJ/kg, and C, H, O and S are the elemental mass fractions of the material. However, Eq. (1) is only valid when the O<sub>2</sub> content of the biomass is less than 10% [31].

The Boie equation is given by the following [31]:

$$HV \text{ (MJ/kg)} = 35,160 \times C + 116,225 \times H - 11,090 \times O + 6,280 \times N + 10,465 \times S \quad (2)$$

where, C, H, O, N and S are the elemental mass fractions of the biomass material.

SCB is known to have a low heating value between 17 and 20 MJ/kg [23] because of its high O<sub>2</sub> composition, which is typical of biomass materials. Feedstocks with high heating values are always better for gasification, and the conversion efficiency of a gasification process is based purely on energy in the feedstock [34,35]. A high heating value material is beneficial as it leads to improved functionality and reduced energy use of feedstock conveyor at power plants [36]. The heating value of biomass is actually dictated by the amount of C and O<sub>2</sub> in the biomass, with the material having a higher amount of O<sub>2</sub> than C, which as a result lowers the calorific value per unit volume of the material [37]. Low energy density of biomass implies that cost of transportation would be high per unit energy, with more space required for storage, thereby, making material logistics expensive. System efficiency is also affected by low energy dense materials; and low energy density also means that more fuel would be required to obtain the same amount of energy [3,38].

#### 4.3. The bulk density of sugarcane bagasse

Efficient and economic conversion of biomass to energy rests on consistent and economic transportation of the biomass from the field to the bio-refinery. One major factor that affects the delivery cost of biomass is its bulk density during collection and transportation as well as during storage [39]. Bulk density is a biomass property that not only determines the cost of feedstock delivered to a bio-refinery, but also affects the design and operation of energy conversion systems and heat transfer equipment [40]. The bulk density of a material, denoted  $\rho_b$ , is defined as the weight per unit volume of that material, expressed in kilograms per cubic metre (kg/m<sup>3</sup>), and depends on certain factors such as composition, particle size ( $l$ ,  $d$ ) and shape ( $\phi$ ) as well as particle orientation ( $s$ ) and specific density of individual particles ( $\rho_p$ ) including particle size distribution (PSD) and moisture content ( $\omega$ ) of the biomass material [41,42]. The relationship between these parameters is given in Eq. (3) [43].

$$\rho_b = f(c, \rho_p, l, d, \phi, s, PSD, \omega, p) \quad (3)$$

where  $l$  and  $d$  are particle length and diameter respectively.

The variables on the right hand side of Eq. (3) are not all independent of each other. For example, moisture content has an impact on particle density. Similarly, particle size and distribution depends on the type of pre-processing method applied during the preparation of the biomass such as drying or grinding, while a

shape factor ( $\phi$ ) for the particle is defined by length ( $l$ ) and diameter ( $d$ ) of the particle. Bulk density is also affected by other factors such as surface characteristics of the biomass [43]. For biomass materials, bulk density is commonly expressed on an oven-dry-weight basis (with moisture content of the biomass nearing zero percent), or as received basis where the biomass moisture content (MC<sub>w</sub>) is indicated. Most biomass feedstocks generally exhibit low bulk densities, including SCB which has a relatively low bulk density (75–200 kg/m<sup>3</sup>), compared to other biomass materials; the bulk density of biomass can be determined experimentally from the following equation [3,24,29,43]:

$$\rho_b = \left( \frac{w_2 - w_1}{v} \right) \quad (4)$$

where  $\rho_b$  is the bulk density of the biomass material in g/cm<sup>3</sup>,  $w_2$  is the weight of the container and biomass in grams (g),  $w_1$  is the weight of the container in grams (g), while  $v$  is the volume of the container in cm<sup>3</sup>.

Fibrous materials with larger particles have low bulk density because they have more pore volume than smaller particles [44]. Low bulk density materials create feeding difficulties in gasification systems as materials with low bulk density do not allow for gravity feed inside the gasifier, a condition that leads to poor combustion conditions within gasification systems, resulting also in reduced process efficiency [45].

#### 4.4. Microstructure, macrostructure and chemical composition of sugarcane bagasse

SCB is highly complex in structure as well as in chemical makeup, so to better understand and describe thermochemical conversion processes using bagasse as feedstock for energy production, examination and analysis of the microstructure and macrostructure as well as the chemical makeup of bagasse are necessary [3]. The microstructure of bagasse is linked to its low molecular weight substances which include the organic and inorganic substances present in its structure, while its macrostructure are related to the cellulose, hemicellulose, and lignin present [46]. A diagrammatic representation of the composition of SCB based on the micro and macromolecular substances present is shown in Fig. 2.

Cellulose and hemicellulose have the formulae (C<sub>6</sub>H<sub>10</sub>O<sub>5</sub>)<sub>m</sub> and (C<sub>5</sub>H<sub>8</sub>O<sub>4</sub>)<sub>n</sub> respectively. These two compounds are polysaccharides with degree of polymerisation represented by  $m$  and  $n$ , and with degrees of polymerisation that are less than 10,000 and 50–300 for cellulose and hemicellulose respectively [22]. Lignin is highly irregular in structure and consists of aromatic, phenolic and various hydrocarbon groups. However, the fraction of these three main components of SCB varies among the species of sugarcane as well as its origin; therefore, the composition of SCB is usually written in

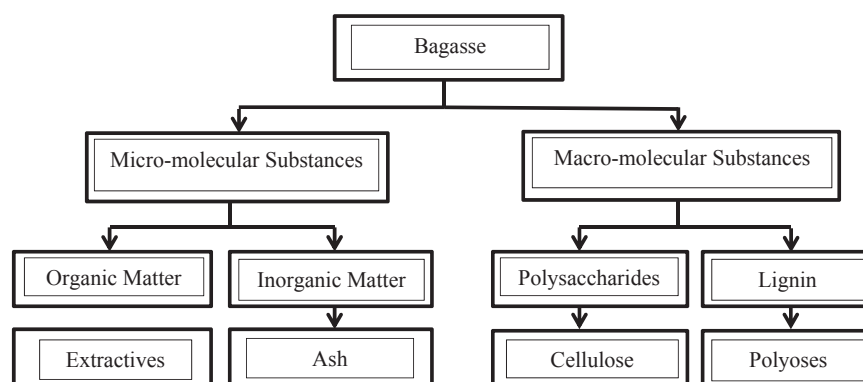
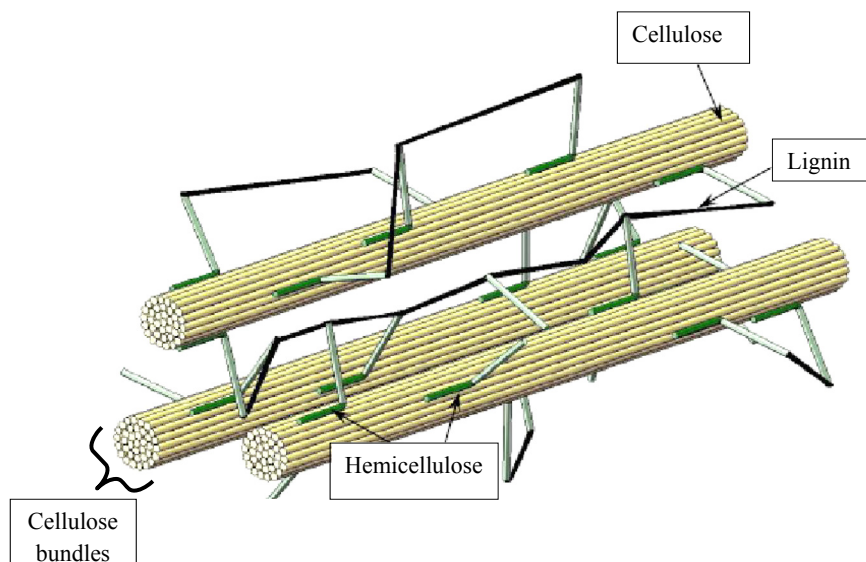

Fig. 2. A schematic representation of the composition of sugarcane bagasse. Copyright American Chemical Society. Reproduced with permission from [46].



**Fig. 3.** Structural arrangement of the plant cell wall showing the location of cellulose, hemicellulose and lignin in the plant matrix. Reproduced with permission by Elsevier from [50,51].

empirical form as  $\text{CH}_x\text{O}_y$ , which is based on the molar fraction of the elements present in bagasse [3]. Lignin provides many structural functions in plants including acting as glue to the cellulose and hemicellulose fibres, and as intrinsic resin. It also helps to form pellets or briquettes without binders because of its thermosetting properties at working temperatures of  $> 140^\circ\text{C}$  [47]. Adhesion in the structure of lignocellulosic plant material is permitted by the lignin content of that material, acting as a bulking and rigidifying agent; and the strength characteristics of briquettes made from lignocellulosic biomass materials are attributed to the adhesive properties of thermally-softened lignin [48,49]. The arrangement of cellulose, hemicellulose and lignin in the plant matrix is shown in Fig. 3. This is presented to better understand the arrangement of the main constituents of plant biomass and the structural functions of lignin.

The chemical composition of SCB or any biomass material for that matter is highly dependent on the material species and its source [22]. Studies have shown that C, H<sub>2</sub> and O<sub>2</sub> are the predominant chemical elements contained in SCB. In addition, a number of other inorganic elements are also present which represents the major source of metallic ions and other acidic substances that are formed when bagasse is combusted or gasified, including trace elements which act, even at very low concentrations [3]. However, the behaviour of cellulose during gasification is important in understanding the gasification of biomass materials as gasification rate becomes faster with increased biomass cellulose content, with tar and gas yields increasing as the content of cellulose increase, while char yield decreases; the main gas products from cellulose are CO<sub>2</sub> and CO due to monosaccharides compounds such as glucose from cellulose, which are decomposed through a decarboxylation process. The reaction behaviour of hemicellulose is similar to that of cellulose, while lignin decomposes at a much wider temperature range forming CO<sub>2</sub> and CH<sub>4</sub> during gasification, due largely to the dealkylation of the side chain of the alkylphenols in the lignin structure [52].

## 5. Issues related to sugarcane bagasse utilisation

There are various technical issues related to the use of sugarcane bagasse (SCB) as a fuel for energy production purposes. These are low energy density, low bulk density, high moisture

content and high metallic ion content as well as heterogeneous size, weight and shape, including storage related problems [3]. These shortcomings, as previously highlighted, limits the use of bagasse as feedstock for energy production due to certain operational challenges experienced during the conversion process of the material, which include low process efficiency [23]. In addition to the problems earlier highlighted for materials with low bulk density, handling and transportation challenges including storage and combustion process challenges with regard to gravity feeding in the conversion system are also issues related to materials with low bulk density. This would remain prone to caking in the pyrolysis zone of the conversion system, a condition which increases the possibility of bridging in the system; therefore, for bridging to be avoided, the ratio of the throat diameter to fuel diameter should be at least 6.8:1 [53]. Since gasification involves a series of concurrent and parallel reactions, the thermochemical processes taking place in the reactor is influenced by devolatilisation, which in turn affects the yield and composition of the product gas, while heating at an optimum rate for rapid devolatilisation of the major components may also be hindered with feedstock having low bulk density [54,55]. High moisture content also indicates that the already low energy density of bagasse would be further reduced as it leads to a reduction in energy value which could result in the production of less heat per unit mass of material during thermochemical conversion of bagasse, subsequently leading to reduced process efficiency. The high metallic ion content of bagasse leads to the production of acidic substances that may corrode system components, which may require intermittent replacement because of the production of highly corrosive ingredients, and may also result in plant shutdown; heterogeneous size, weight and shape also create problems related to decrease in specific area and surface energy per unit mass of bagasse, which may not facilitate faster rates of heat transfer [3]. Feeding biomass into the conversion system also becomes a challenge with irregular feedstock size, weight and shape as these may lead to some sort of blockages within the conversion system, resulting in poor combustion conditions, usually necessitating that some conversion systems are strict in terms of feedstock size requirements [3,45]. SCB, by its very nature consists of degradable or fermentable materials and represents a bulk material that presents a media through which moisture can migrate or be absorbed, a factor that add to storage related problems such as compounded mass loss due to microbial

contamination and wind erosion as a result of exposure to the environment leading to under-usage of the feedstock [16,23]. This factor greatly affect thermochemical conversion systems using bagasse as feedstock for energy production purposes due to the high level of impurities and particulate matter as well as high amount of tar produced along with soot formation and agglomeration, making the technologies unattractive [3].

## 6. The pre-processing of sugarcane bagasse

There are many challenges of efficiently converting raw SCB into usable and affordable customised bioenergy feed material. The pre-processing of SCB is intended to overcome technical issues of using bagasse as feedstock for energy production. Some of these issues have been previously highlighted, and the quality of a pre-processed material depends on the pre-processing methods applied [27]. As earlier mentioned, large quantities of bagasse is generated for every ton of cane crushed [13]. While most of this is consumed internally as fuel in boilers, there are still huge excess quantities to be handled. This excess quantity and the heterogeneous form in which it is present pose a serious challenge related to fire hazards to the sugar mill where it is mostly used. In addition, microbial reaction can lead to spontaneous combustion due to the burning properties of SCB [16]. Therefore, one of the measures that would help mitigate these hazardous conditions is to resort to efficient methods of disposing the excess bagasse generated, but yet maximizing this disposal process by thermochemically converting it to useful energy. This would, however require efficient pre-processing steps due to the disperse nature of bagasse and other inherent technical issues previously described. Apart from these challenges, pre-processing of SCB also allows the removal of foreign materials and dirt, eliminating significant downstream conversion issues related to the formation of slag and other foreign material issues.

## 7. The various pre-processing methods to improve bagasse quality

Biomass, including SCB is difficult to work with when compared with conventional fuels like coal, which are used by a variety of energy conversion systems, with their benefits making them almost the exclusive source of energy for most industrial systems [56]. This has significantly limited the deployment of the conversion systems using biomass as feedstock for energy production purposes. SCB in its original form is difficult to successfully use as a feedstock in conversion systems for energy production purposes under the current circumstances in which it is generated. This has been largely due to its wet and dispersed nature as well as other issues previously pointed out. However, the process of gasification is the most demanding among all thermal conversion processes in terms of product end-use, which can be affected by pre-processing of the feedstock to be converted [57]. As earlier stated, pre-processing of biomass is usually applied to reduce technical challenges associated with low bulk and energy densities as well as heterogeneous size. Among the pre-processing methods available to overcome the technical issues of using SCB as an energy resource, and to make it a valuable feedstock are drying, grinding, densification, torrefaction and steam explosion. A detailed description of these methods and a comparison of their advantages and disadvantages are given in the following sub-sections.

### 7.1. Densification

The most serious biomass size or shape-related problems when using improperly sized or shaped materials are issues linked to the chemistry of the biomass and its conversion process. Biomass thermochemical conversion to energy takes place at the interface of heat, O<sub>2</sub>, and the biomass as well as other reactive components as an interface reaction on the surface of the biomass material. Densification is one pre-processing method usually applied to achieve uniform properties and to increase the densities of biomass materials [27]. With densification, the problem of heterogeneous size and shape are addressed. A densified material is easy to handle, transport and store and densification can be achieved with most biomass materials including SCB, provided that they attain the correct moisture content and particle size [56]. Methods commonly used to achieve densification are pelleting or briquetting. These methods are detailed in the following sub-sections. A comparison of the different technologies for densification is also described including the advantages and disadvantages of each technology as well as their process variables.

#### 7.1.1. Pelleting

The issues stated earlier of using bagasse for energy production makes the material difficult and expensive to store, handle and transport. Bagasse pelleting could potentially reduce storage and handling costs. It could also reduce the consumption of fuel oil (residue obtained from petroleum distillation) at the mill, resulting in viable use of these alternatives. However, the use of biomass pellets or briquettes for energy production purposes depends largely on the type of conversion system employed [27]. Energy conversion systems such as the fixed bed downdraft gasification systems are relatively strict in terms of size requirements. Therefore, feedstock for conversion in these systems must be uniformly sized from 4 to 10 cm in length, and about 30–50 mm in diameter so as to avoid blockage of the throat of the gasifier, as blockage may lead to poor gasification conditions. As a result, the use of pellets in this type of gasifier is highly discouraged due to the size of the pellets, as blockages may occur within the combustion zone of the gasifier, resulting in combustion (a condition that leads to poor process efficiency) instead of gasification [45].

Even though biomass pellets have specifications, there are various sizes, densities and composition of pellets produced depending on how the biomass material is to be utilised [56]. Pellet shape is determined by the equipment used to make the pellet. Fig. 4 shows sugarcane bagasse pellets obtained from a pellet mill.



Fig. 4. Sugarcane bagasse pellets. Used with the permission of Hang Xanh International from [56].

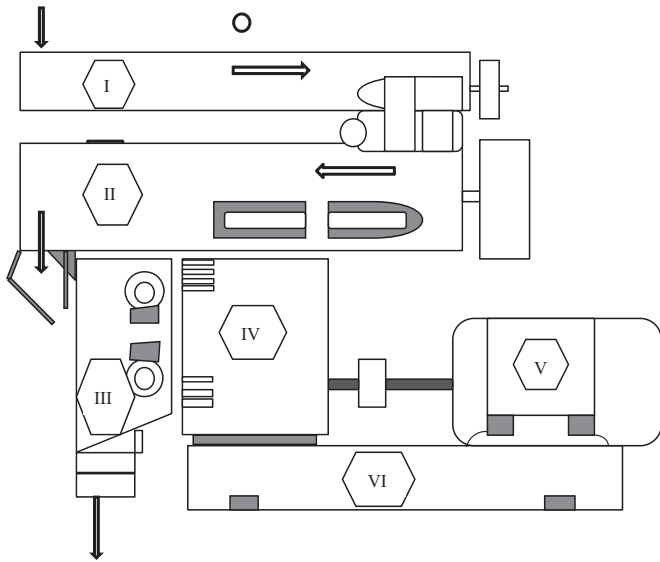

Fig. 5. A schematic diagram of a pellet mill. From [58]. Used with permission.

**7.1.1.1. The pellet mill.** Basically, pellet mills are designed in such a way that a large roller pushes the biomass through a small hole in a thick metal die that gets narrower around the centre of the die as the material gets compressed, binding together in the process under high temperatures. Pressure and friction between the die and the biomass cause significant heat up of the pellets as the material is compressed. Cutters are used to chop the pellets into length as the material begins to cool in its new shape of pellets on the other side of the die which is approximately 30 mm in diameter. The size of most pellets produced is in the range of 1/4" and 9/19" [56]. A schematic diagram of a typical pellet mill is shown in Fig. 5, where I, II, III, IV, V and VI represents the feeder, the conditioner, the pelleter, the speed reducer, the motor and base of the mill respectively.

The working principle of the pellet mill is such that the material from the feeder is uniformly delivered to the conditioner under controlled addition of steam or a binder to improve the process of pelletisation. A permanent magnet is used to discharge the feed from the conditioner into a feed spout which leads to the die of the mill. The rollers of the mill are driven by friction as the die revolves, forcing the feed through holes in the pelleting die. Fig. 6 presents a schematic of a typical pellet mill die with holes in between the die. The pellets extrude through the holes in the die.

I, II and III represent unpelleted material, the pellets extruded through the die plate, and pellet knives respectively. The unpelleted material is forced through the holes of the die and is made to extrude via a plate on the die of the mill as represented by the schematic diagram in Fig. 6. The pellet knives chop the pellets into size.

Pelleting may be a viable option for most biomass conversion systems because of the ease of handling of pellets, however, a major limitation in using biomass pellets is the energy requirements and associated cost of producing them. Compressing the biomass material through the openings of the die requires the use of large motors, which in turn requires large amount of energy for compression to be achieved [56]. Furthermore, the biomass material must be fairly small so as to be forced through the holes of the die, which may require the use of hammer mills to get the material into sawdust form. Therefore, the costs of energy and equipment for pelletisation are significant limitations of using this form of densified biomass feedstock. The power consumption of the pellet mill is in the range of 15–40 kWh/t of biomass [59]. Another disadvantage associated with the use of biomass pellets is

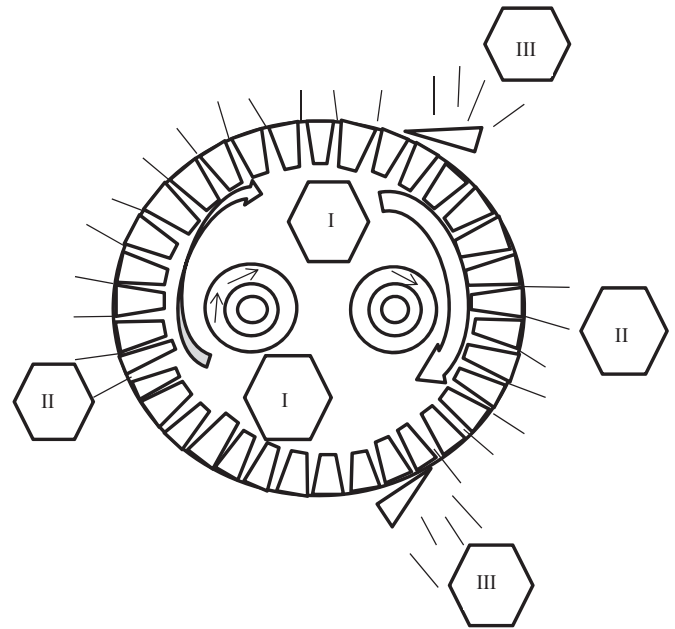

Fig. 6. The schematic diagram of a pellet mill die and its working principle. From [58]. Used with permission.

the generation of dust during feeding into the conversion systems because the pellets are easily disintegrated causing difficulties in handling [27]. In addition, the pellet mill is unable to handle large-sized feedstocks with high moisture contents [58].

### 7.1.2. Briquetting

Briquetting is a high-pressure compaction technology used to increase the densities of biomass materials and remains a viable and attractive solution to biomass utilisation as a potential feedstock for energy production. The process of briquetting is usually carried out with a hydraulic, mechanical or a roller press type of briquetting machine. After briquetting, the densities of the biomass are increased between 900 and 1500 kg/m<sup>3</sup>, which can conveniently be used in conversion systems or even in open fires; and larger sizes of materials with higher moisture contents can be handled by a briquetting machine unlike the pellet mill. Briquetting increases biomass densities and address the problem of heterogeneous size and shape of the biomass, resulting in uniform and improved combustion characteristics as well as low particulate emissions [27]. The technologies for briquetting are classified according to the method used to compress the material. These include the piston press, the screw extruder and the pellet mill which has earlier been described. The piston press densification technologies include the hydraulic piston press, the mechanical piston press and the roller press [60]. The following section elucidates the types of briquetting technologies that can be used for the densification of biomass. Their merits and demerits are also described.

**7.1.2.1. The hydraulic piston press.** The most common type of briquetting machine used for biomass densification is the hydraulic piston press, due to the ease of charging its furnace, its compact and light nature and its low output levels [27]. This type of briquetting machine works on a principle of fluid-pressure transmission that is based on Pascal's law, where the pressure exerted anywhere in a confined incompressible fluid is transmitted equally in all directions throughout the fluid in such a way that variations in pressure remain the same. A schematic representation of the hydraulic press briquetting machine is presented in Fig. 7.

The material for briquetting is fed through the feeding cylinder



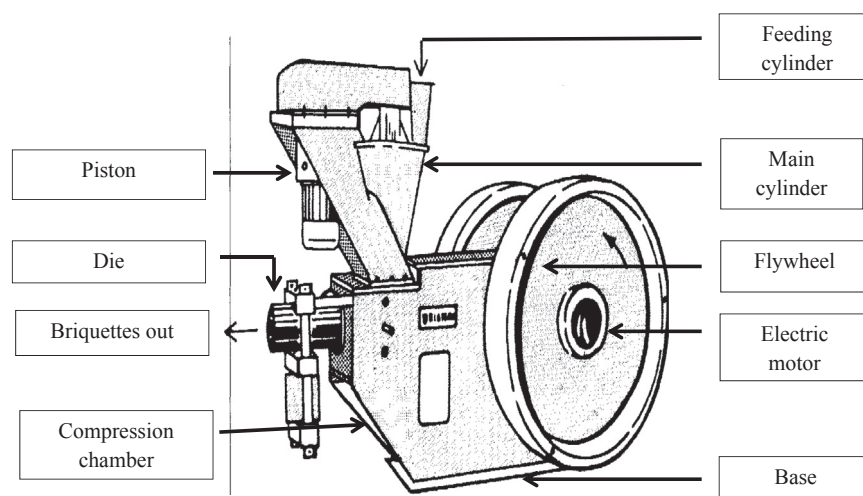

Fig. 7. Schematic of a hydraulic piston press showing its components. From [58]. Used with permission.



Fig. 8. Sugarcane bagasse briquettes from a hydraulic press. From [62]. Used with permission.

which often works by pre-compacting the material before the main cylinder is pressurised. Energy is transmitted from the electric motor as it rotates, to the piston which pushes the material into the compaction chamber where material compaction takes place. After compaction, the material is further pushed from the compaction chamber to the die section which allows for controlled expansion and cooling of the briquettes. The briquetted material then finally extrudes through the die, assuming the size as well as the shape of the die. The pellets are released from the die relatively warm and fragile, and would therefore need to be cooled further before it can be cut to the desired size [61]. Fig. 8 shows bagasse briquettes made from a hydraulic piston press type of briquetting machine.

The bulk density of briquettes is lower than  $1000 \text{ kg/m}^3$  due to limited pressure which is usually about 30 MPa; however, the hydraulic type of briquetting machine can tolerate material moisture content above 15% [61]. Another advantage of this type of briquetting machine is its limited daily service due to its long technical life. The die, piston and cylinder of the hydraulic press are the main wear parts, and the service lives given by manufacturers of this type of machine for these parts are between 500 and 1000 h [60].

**7.1.2.2. The mechanical piston press.** The mechanical piston press is a type of briquetting machine typically used for large-scale

production of biomass briquettes ranging from 200 to 2500 kg/h [27]. It is designed as an eccentric press due to the mechanism of compaction, which transforms rotational force from the motor into a force that performs the compression; hence it is primarily a mechanical process. In this type of briquetting however, the piston reciprocates after mounting it eccentrically on a crank-shaft with a rotating flywheel. An oil-bath is used to hold the shaft and the piston rod as well as the guide for the rod. Fig. 9 shows a typical mechanical piston press used for biomass densification.

The top of the piston of a mechanical piston press is normally shaped with a half-spherical section that protrudes and functions to get adherence of the compressed material from the one previously formed in the stroke. The die has a diameter in the range of 40,125 mm and remains a key factor that determines briquette quality [61]. The high forces acting during compression are absorbed by the moving parts which are mounted within a sturdy frame. Compression pressure in the mechanical briquetting press is in the range of 110–140 MPa, and a combination of this pressure with the heat produced as a result of friction from the walls of the die raises the temperature of the material to a level where the lignin content of the biomass begins to melt, acting as a binder in the process to produce a stable briquette [61]. Unlike the hydraulic piston press which is driven by a hydraulic motor, the mechanical piston press is driven by an electric motor. Energy loss in the machine is minimal with optimal output in relation to power consumption [27]. Fig. 10 presents a process flow diagram for ceaseless briquetting using a mechanical piston press.

After grinding, the material for briquetting is fed from a feeding system that is designed with a drilling device inside and which functions by rotation to push the material up by centrifugal force to the cyclone where separation of air and the raw material takes place through gravity and vortex. The feeding system is mounted some distance away from the briquetting press as shown in Fig. 10. The rotary valve also functions by rotation, regulating the passage of the material from the cyclone into the dosing silo which acts as a storage tank and designed with a protruding feeding screw somewhat underneath. The protruding screw system pushes the material from the silo to the briquetting machine where the material is compressed under high pressure (between 110–140 MPa). The briquettes are formed through the die section of the machine and remains relatively warm and fragile until cooled further before being cut into pieces of the desired size.

**7.1.2.3. The roller press.** Roller press briquetting machines have been in use since 1870 and operate on the principle of pressure and agglomeration such that pressure is applied between two

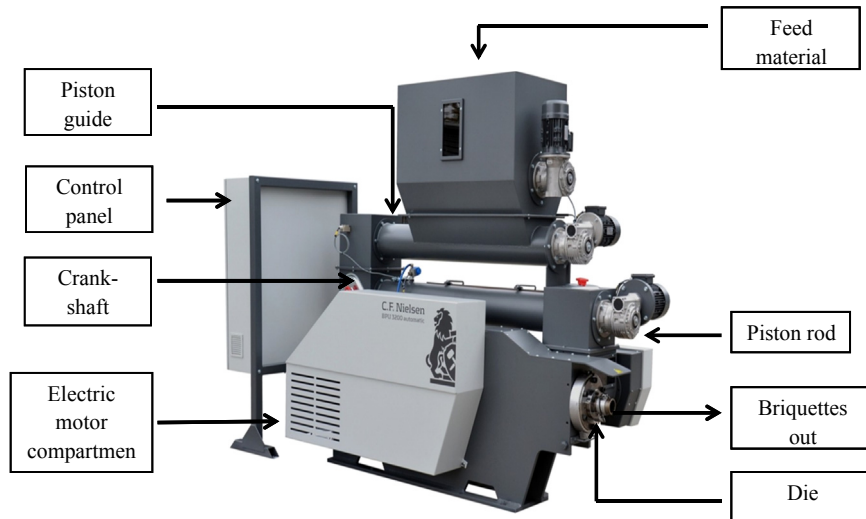

Fig. 9. Main features of a mechanical briquetting press. Used with permission from [63].

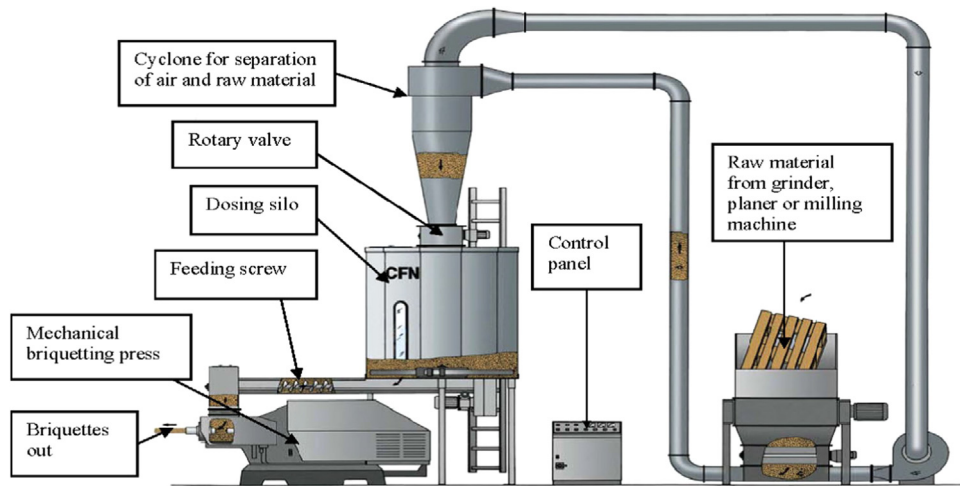

Fig. 10. Flow diagram for ceaseless briquetting using a mechanical piston press. Used with permission from [63].

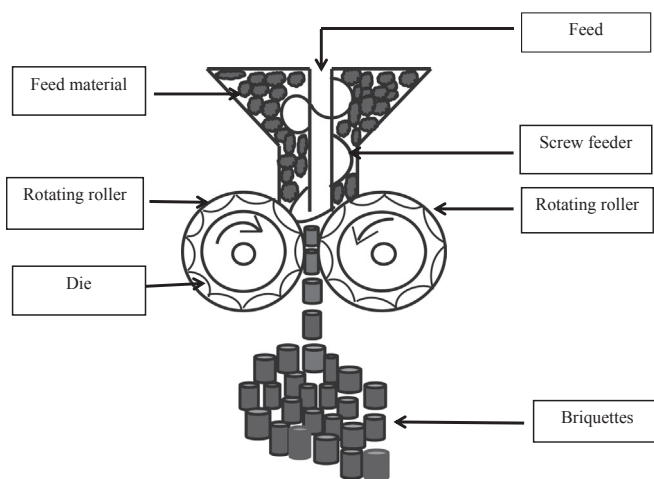
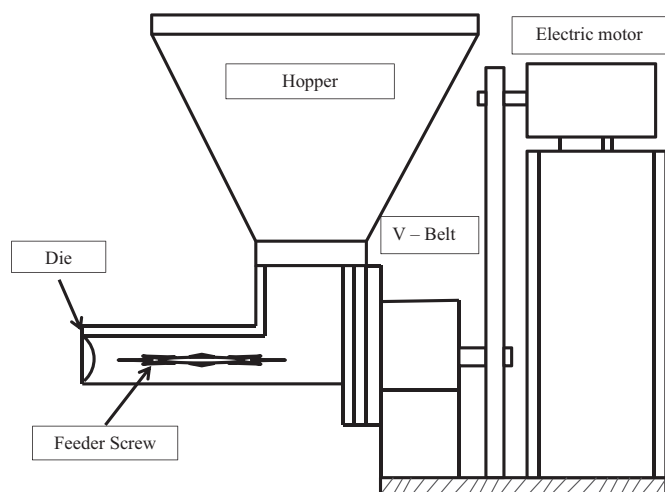

Fig. 11. Schematic of a roller press briquetting machine. From [58]. Used with permission.

counter rotating rollers. Briquetting using roller presses happens to be another approach readily adapted to densifying biomass materials to use for energy applications [58]. A schematic diagram of the roller press briquetting machine is shown in Fig. 11.

In roller presses, the material for briquetting is compressed between two counter-rotating rollers such that initial densification occurs through compression by the screw feeder in the feed mechanism. Removal of air from the material is the primary purpose of the initial densification process. The rollers are designed and arranged in such a way that a small gap exists between them to allow for compression; and the distance between the two rollers depends on a number of factors such as particle size, type of biomass and moisture content of the biomass [24]. High pressure is created as the material flows between the two rollers, resulting in final compaction of the material. The two rotating rollers function by drawing the feed material on one side, and the briquetted material discharged on the opposite side of the rollers with die openings to form the briquettes of the desired shape and size as the material passes in between the rollers. The shape of the briquetted biomass is dependent on the type of die [64].

**7.1.2.4. The screw compaction technology.** Screw presses were originally developed and used for sawdust briquetting. The aim of using the screw press for briquetting is for smaller particles to be brought closer to each other so that they are made stronger due to the forces acting on them, and in effect, providing more strength to the briquetted material [27]. During briquetting using the screw press, a rotating screw helps to move the material from the feed port through the barrel and against the die of the press. This



**Fig. 12.** A schematic diagram of a screw extruder. Reproduced with permission from [61].

results in significant pressure and friction between the walls of the barrel and the material due to shearing of the material [27]. Fig. 12 shows a schematic of a typical screw extrusion press for biomass briquetting.

The screw extruder basically works by continuously forcing the material into a die with the help of the feeder screw. The biomass is heated under increased temperature due to the combined impact of the high rotational speed of the feeder screw and the barrel wall friction as well as the internal friction in the material. The heated material is forced through the die of the extruder to form briquettes with the required shape or size. The main demerits of the screw press include the severe wear issue of the die and its head which results in high maintenance cost as well as its power requirements, which is also high when compared to the piston press such as the hydraulic, the mechanical or the roller press; however there are various advantages associated with the use of this technology, one of which is its continuous output with more uniformly sized briquettes as well as partially carbonised outer surface of the briquettes, which helps facilitate ignition and combustion and protects the briquettes from ambient moisture including the fact that the briquettes form a concentric hole that helps for better combustion due to air circulation during briquette combustion; the screw extruder also runs smoothly without any load-attributed shock [59]. Fig. 13 shows a heat log with a concentric hole made from a screw extruder.

The specification of a typical briquette made from a screw extruder is given in Table 3. This is presented to better understand the features of biomass after screw press method of pre-processing.

It is evident from Table 3 that the bulk density of briquettes increased significantly from  $200 \text{ kg/m}^3$  to  $1400 \text{ kg/m}^3$  after screw extrusion, which is typical of a briquetted biomass material made from a screw extruder. The high bulk density results in improved combustion characteristics of the briquettes and allows for gravity feeding with reduced particulate emission when combusted in thermochemical conversion systems [27,45].

## 7.2. Comparison of different technologies used for densification

There are various technologies available for densification of SCB. These technologies are classified according to the type of equipment and mode of operation including the operating conditions of the equipment as well as the applied pressure and temperature [65]. Table 4 summarizes the comparison between the various densification technologies in terms of the properties of



**Fig. 13.** Briquette with a concentric hole produced from a screw extruder/press. Used with permission by New-Air Technical Services Ltd. Leicester, England from [27].

**Table 3**

General briquette specification made from a screw extruder. Used with permission by New-Air Technical Services Ltd. Leicester, England from [27].

Material prior to extrusion	
Moisture content	8%
Average particle size	2–6 mm
Bulk density	$200 \text{ kg/m}^3$
Calorific value	$17.8 \text{ MJ/kg}$
After extrusion	
Moisture content	4%
Bulk density	$1400 \text{ kg/m}^3$
Calorific value	$19.53 \text{ MJ/kg}$
Ash content	0.3–0.5%

the feedstock, the energy consumption of each technology and the suitability of the densified material for different end-use applications.

It is evident from Table 4 that the screw extruder has a higher wear rate compared to other densification technologies (even though the briquettes made from it may be suitable for gasification), which results in high maintenance cost and this wear rate supports its demerits previously mentioned [58]. It is also clear from Table 4 that the energy requirement of the screw extruder is higher than the other densification technologies with  $36.8 \text{ kW h}$ , being the minimum energy that can be consumed per ton of briquettes [58]. For the piston press, the maximum consumable energy is about  $77 \text{ kW h/t}$ , which is significantly less than that consumed by the screw extruder. The roller press and the pellet mill have low maintenance costs even though they are characterised by high wear rates, which is most probably due to their low energy consumption rate [58].

## 7.3. Densification systems process variables

Studies have shown that process variables such as pressure, die temperature and die geometry play a major role in densification of biomass. Other process variables that also play major roles include material variables such as moisture content, particle size and

**Table 4**  
Comparison of the performance of different densification technologies [58,59,66,67].

	Piston press	Screw press	Roller press	Pellet mill
Optimum moisture content of material	10–15%	8–9%	10–15%	10–15%
Particle size of material	Larger	Smaller	Larger	Smaller
Wear of contact parts	Low	High	High	High
Output from machine	In strokes	Continuous	Continuous	Continuous
Specific energy consumption (kW h/t)	37.4–77	36.8–150	29.91–83.1	16.4–74.5
Throughputs (t/h)	2.5	0.5	5–10	5
Density of briquettes/pellets	1000–1200 kg/m <sup>3</sup>	1000–1400 kg/m <sup>3</sup>	600–700 kg/m <sup>3</sup>	700–800 kg/m <sup>3</sup>
Maintenance	Low	High	Low	Low
Combustion performance of briquettes	Moderate	Very good	Moderate	Very good

shape; and material composition such as cellulose, hemicellulose and lignin [51]. System variables for densification are important if the desired densities, durability and quality of the densified material are to be achieved, with proper process conditions ensuring improved briquette quality [27,68]. The following sections highlights the process variables that play important roles in attaining the desired product quality during briquetting of biomass, and these quality attributes are usually measured in terms of density and durability as well as in terms of heating value [27,58].

### 7.3.1. Pressure

Pressure is one important densification process variable that play a major role in the quality of a briquetted biomass material as the density of the material is proportional to the pressure applied since an increase in pressure ensures a significant increase in the density of the material [69]. Fractures may occur in biomass briquettes due to pressure applied beyond the optimum pressure required for briquetting, which may also lead to uneven briquette combustion during gasification of the briquettes. As a result, briquetting pressure should be kept at a value that is optimum to increase deformation due to influence on mechanical strength [69]. Diffusion of molecules from one particle to another at contact points may form solid bridges due to the application of high temperatures and pressure during briquetting, leading to a rise in briquettes density [27]. When a biomass material is compressed at a pressure rate of about 0.24–5 MPa, there seem to be a significant effect on density when moisture content of the biomass remains at about 10.3% [70]. A pressure increase from 300 to 800 MPa with material moisture content of 7% on a wet basis would sharply increase the density of the material by 78.6% during compaction [71].

### 7.3.2. Temperature

The importance of temperature during densification of biomass cannot be overstated because it greatly affects quality attributes such as bulk density and durability, and high temperature conditioning during densification results in increased durability [72]. Past studies [71] showed that the rate of compaction and dimensional stability increased at temperatures between 60 and 140 °C during briquetting of biomass, and that briquette expansion was reduced when system die temperature was between 90 and 140 °C. Due to chemical degradation, a charred surface and slight discoloration could be noticed on briquettes at temperatures above 110 °C, while significant improvement on durability could be achieved at temperatures less than 90 °C [73,74]. The glass transition temperature (75 and 100 °C) behaviour of lignin can be used to understand biomass behaviour during densification because temperature is inversely proportional to the moisture content of the biomass material [75]. Another study by Kaliyan and Morey [75] using three different temperatures, which included two within the glass transition temperature range and one outside it (150 °C), suggests that the temperature outside the glass

transition temperature and the durability values of the material were lower compared to the ones within the temperature range.

### 7.3.3. Die geometry and speed

The geometry (shape and size) of the die greatly affect both the amount of material that can be densified and the energy required for densification, and influences material properties such as bulk density and durability as well as moisture content, with degree of compression determined by die length to diameter (L:D) ratio during densification [27]. The pressure needed to press materials through the press channels in the matrix and through the matrix itself is actually determined by the die dimensions of the densification system, where the density of the briquette is greater for a constant mass of material when smaller die diameters are used at a given pressure [76]. The impact of die geometry and die speed as well as particle size of biomass was studied by Tabil and So-khansanj [73]. They found that using a smaller die with higher length to diameter (L:D) ratio significantly increased the durability of briquettes at a die speed rotation of about 250 rpm. Barrel temperature of the die and screw speed also affects, to a great extent, quality attributes such as density and hardness of the biomass material during densification using a screw extruder [77]. It has also been found that the flow rate of biomass feed is significantly affected by length to diameter ratio (L: D) of the die and screw speed during densification using a screw extruder, and the quality of the final briquetted material is also greatly affected by this flow behaviour [78]. The effect of three die sizes on durability of briquetted biomass was also studied by Heffner and Pfost in 1973 [79]. They used die sizes of 4.8 × 44.5, 6.4 × 57.2, and 9.5 × 76.2 mm respectively. Their results showed that the best durability values were briquettes produced on the smallest die (4.8 × 44.5).

### 7.3.4. System retention time

Briquette quality is also greatly affected by the time interval between the point of feeding into the densification system and the time required for compaction [73]. A study by Al-Widyan et al. [78] found that retention time between 5 and 20 s had no significant impact on the quality and durability of biomass briquettes, while Li and Liu [68] also concluded that at low pressure, retention time had more impact on the durability and stability of briquettes than at high pressure, concluding that at the highest pressure of 138 MPa, the impact of retention time became negligible. The effect on density of biomass briquettes is also negligible for a retention time greater than 40 s; and a 10 s time of retention could result in a 5% increase in briquette density whereas the effect could significantly be reduced at retention times longer than 20 s [27]. Generally, retention time has a significant impact on the density of biomass materials and depends on a number of factors such as temperature, pressure, flow rate, and so on. The final briquette obtained during densification would also depend on system die geometry, the magnitude and mode of compression as

well as the type and properties of the biomass including storage conditions [27].

#### 7.4. Torrefaction

In torrefaction, biomass materials are heated between the temperatures of 200–300 °C to change their properties to obtain a much better feedstock quality for energy conversion purposes [38]. Torrefaction involves heating the biomass to a target temperature in the complete absence of O<sub>2</sub> to drive off H<sub>2</sub>O and volatiles in order to increase the energy density of the material [78]. This process is described as a mild form of pyrolysis since volatiles are removed, resulting in a product with about 80–90% of the original calorific value of the material, but with only 70% of the initial weight [80]. The torrefaction process results in a very dry product with essentially no biological activity leading to microbial spoilage [80–82].

There are many advantages associated with torrefaction of biomass which include reduction in feedstock variability caused by differences in types and species of the biomass, climatic and seasonal variations as well as storage related conditions [83]. Torrefaction helps develop a feedstock with uniform properties and improves the physical characteristics of the material [84]. The feedstock properties affected are hydrophobicity, grindability and the ability of the material to form briquettes. The lignin content of biomass is considered the basic binding agent in the material, and the ability of any biomass material to form briquettes is evaluated on the basis of the amount of lignin contained in the material [27]. It is therefore, generally believed that the higher the amount of lignin in a biomass material, the better the binding ability of that material and the milder the process conditions. A number of lignin-active sites are opened up during the process of torrefaction, breaking down the hemicellulose matrix to form unsaturated compounds with better binding properties [85]. A flow diagram for the production of torrefied biomass briquettes as proposed by Bergman in 2005 [86] which could make the material suitable for energy conversion purpose is presented in Fig. 14.

During torrefaction, most of the water contained in the biomass is evaporated as the material undergoes drying and heating. This happens due to chemical reactions via a thermo-condensation process at a temperature above 160 °C resulting in the formation of CO<sub>2</sub> [87]. The hemicellulose content of the biomass is more affected by the decomposition reactions than the cellulose and lignin content, with the material retaining most of its energy and losing its hygroscopic properties [88,89]. The production of gas increases, resulting in the formation of CO and other heavier compounds including hydrocarbons such as phenol at reaction temperature of approximately 280 °C. At this temperature, the reaction is considered entirely exothermic. Temperatures beyond 300 °C are not recommended as these temperatures result in pyrolysis instead of torrefaction [90]. During torrefaction, the biomass loses its recalcitrant nature due to the breakdown of its hemicellulose matrix and cellulose depolymerisation, resulting in a reduced fibre length [82,89,90]. The process of torrefaction also results in shrinkage of the material, making it fragile, flaky and light-weight, while improving grinding and pulverising properties, and in the process, making the material hydrophobic mainly due

to the elimination of hydroxyl groups (OH), without the support of hydrogen bond formation [91,92]. Non-polar unsaturated compounds that result from the rearrangement reaction process of torrefaction help preserve the biomass by reducing biological degradation, which may render it less useful for energy production purposes [82,93]. More O<sub>2</sub> and H<sub>2</sub> are driven off as compared to C, increasing the calorific value of the material in the process [94]. The net calorific value of a biomass material that can be obtained after torrefaction is in the range of 18–23 MJ/kg (LHV, dry), or 20–24 MJ/kg (HHV, dry), depending on analysis conditions [89,95]. The proximate and ultimate compositions of the biomass are also significantly changed after torrefaction, making the material suitable for fuel applications [38].

In general, increasing the torrefaction temperature results in an increase in the C content of the torrefied material, with O<sub>2</sub> and H<sub>2</sub> contents decreasing due to the formation of H<sub>2</sub>O, CO and CO<sub>2</sub> [27]. The decrease in the ratio of H<sub>2</sub> to C (H:C) and that of O<sub>2</sub> to C (O:C) as torrefaction temperature and time increase results in less smoke and reduced formation of water vapour as well as reduced energy losses during the process of combustion or gasification [27]. A wide range of torrefaction processes were carried out by Sadaka and Negi [96]. Their results showed a significant reduction in the moisture content of the torrefied material from an initial of 70.5% to a final of 49.4% and 48.6% respectively, with a corresponding increase in calorific value from an initial of 15.3 MJ/kg to a final of 16.9 MJ/kg. Increasing the torrefaction temperature from 230 to 280 °C and time from 1 to 3 h results in an increase in the C content of the material, with a reduction in H<sub>2</sub>, O<sub>2</sub> and N<sub>2</sub> contents respectively due to H<sub>2</sub>O, CO and CO<sub>2</sub> formation [92]. Another study conducted by Bridgeman et al. [97] on the torrefaction of reed canary grass and wheat straw with composition and properties similar to those of SCB showed a reduction in moisture content from an initial value of 4.7% to a final value of 0.8%, with the content of C increasing from a value of 48.6% to a final value of 54.3%, and H<sub>2</sub> decreasing from 6.8% to 6.1% as well as a decrease in N<sub>2</sub> content from 0.3% to 0.1%.

#### 7.5. Drying and demosturising

Moisture content of biomass remains one of the major factors that affect the performance of densification processes and that of energy conversion systems because the quality of a densified material as well as successful operation of densification systems are highly moisture sensitive, which preferably should not exceed 15% [65]. For biomass materials such as SCB which is excessively moist at the source where it is generated, drying is essential if it is to be efficiently used as an energy resource. Drying and demosturising is one pre-processing method required during thermochemical conversion of biomass such as SCB to energy and results in higher quality products. Drying and de-moisturising have been used to form more stable and dense briquettes because it significantly increases the throughput of the briquetting machine, reducing the energy requirement per kg of briquettes formed [98–100]. Following size reduction, moisture content has to be reduced to a considerable level for which a dryer maybe used depending on the conversion technique employed for the biomass material [101]. Drying may also be achieved using the heat

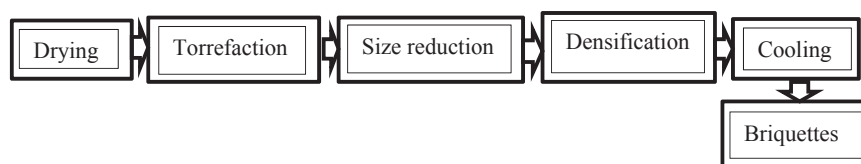

Fig. 14. A flow diagram of the production of torrefied biomass briquettes. Reproduced with permission from [86].

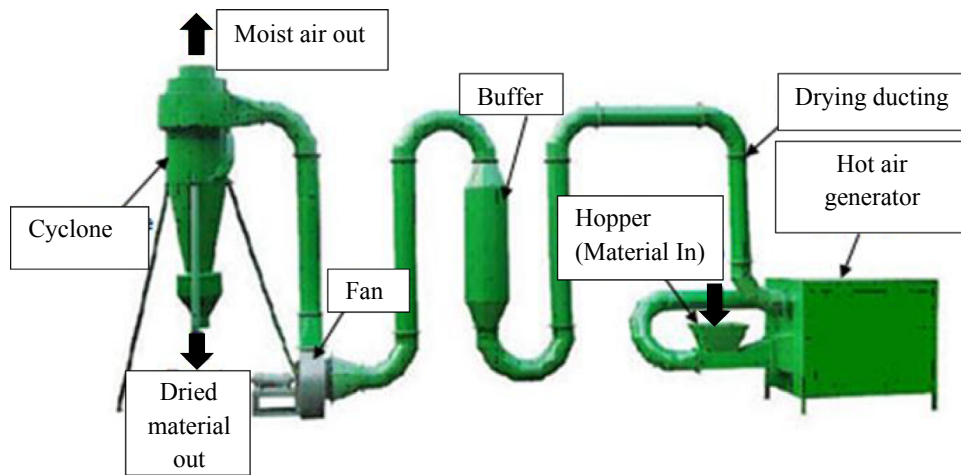

Fig. 15. A pneumatic dryer. Reproduced with permission from [102].

generated from the plant where the biomass is to be converted into energy. Fig. 15 shows a pneumatic-type of dryer that can be used for biomass drying.

Energy is required during moisture removal, which therefore increases the energy needed for pre-processing; however, heat recovery from a waste heat source from the dryer could improve energy efficiency as drying is an essential pre-processing method required in the conversion of any biomass material into energy because this process provides a measure of easy ignition of the biomass during gasification [101]. There are however, different drying methods that can be applied during biomass drying depending on how the biomass material is to be utilised as a source of energy. A classification of these methods is presented in Table 5.

During gasification, excess moisture in bagasse may reduce gasification system thermal efficiency; however, steam generated from moisture evaporation reacts with volatiles and char, converting them into product gas, and playing a role in the water-gas shift reaction (Table 6) which enhances  $H_2$  production [103–105]. This observation is true because of moisture removal due to heating from room temperature to a temperature of approximately  $100\text{ }^\circ\text{C}$ , and the latent heat of vaporisation as well as steam heating to gasification temperature lost from the system increases thermal cost [106].

### 7.6. Grinding

Size reduction of biomass materials are quite demanding due to the fibrous and tenacious nature of their structure. It is an important energy-intensive process that is essential for energy conversion purpose of biomass materials; however, the energy consumption of size reduction depends on certain factors including the initial particle size of the biomass, moisture content, biomass feed rate, biomass properties and the machine variables [107–109]. For thermochemical conversion of bagasse or any other biomass material, size reduction is necessary because most energy conversion systems cannot process feedstocks in their raw form; as previously mentioned, conversion systems are designed to accommodate specific feedstock sizes; hence most systems are

**Table 5**  
A classification of the various methods of drying [101].

Active dryers	Passive dryers
Boilers (flue gas or steam)	Solar dryer
Dryer burners	Open sun
Waste heat recovered from facility processes	Natural ventilation

relatively strict in terms of size requirements [110]. Prior to densification, the biomass is ground to a certain particle size so as to partially break down the lignin content of the material, increasing its specific area and improving binding properties [111]. The total surface area and the pore size of the material including the number of contact points for inter-particle bonding increases with particle size reduction during compression [112]. The process of size reduction is energy intensive, and for this reason, it cannot be met through combustion of the material. However, the energy demand for size reduction can be reduced when the material is first torrefied, and the reduction in energy can be as high as 80% [113].

## 8. The gasification process

Gasification is one of the most flexible technologies that can be used to produce clean energy. It is a thermo-chemical process that breaks down virtually any carbon-containing material into its basic chemical constituents, collectively known as synthetic gas (syngas). This process consists of a number of physical and chemical processes including rate-determining steps, and takes place under limited supply of  $O_2$  so that partial oxidation can increase the efficiency of the entire process [114]. The location of the chemical processes depends on the type of gasification technology, and the three major types are the fixed bed, fluidised bed and the entrained flow gasification systems [115]. A detailed description of these types of gasifiers is given in Section 11. Of these various types of gasifiers, the fixed bed is the most commonly used, and since the downdraft gasifier (which a fixed bed type of gasifier) is the focus of this review, the fundamental chemical kinetics of each gasification technology based on the operation of the downdraft gasifier are described, with emphasis on the four main processes (drying, pyrolysis, oxidation and reduction) occurring in the gasifier. Each of this processes is characterised by its own energy requirements and can be endothermic or exothermic, incorporating heat and mass transfers as well as the chemical kinetics of the reactions and pore diffusion as the main rate-controlling mechanisms involved in the processes. Other types of gasifiers are also reviewed, including their merits and demerits as well as their mode of operation so as to establish a clear justification for the selection of the downdraft gasifier for the gasification of SCB.

Fig. 16 shows the heat and mass flows characterised by the four main gasification processes based on the operation of a downdraft gasification system.

The mechanisms of heat and mass flows vary in magnitude

**Table 6**  
Chemical reactions involved in the gasification of biomass [144,147,148].

Reaction name	Chemical equation	$\Delta H_{923}^{\circ}$ (kJ/mol) <sup>a</sup>
Material reforming	$C_nH_mO_p + (2n - p)H_2O = nCO_2 + (m/2 + 2n - p)H_2$ (5)	- (endothermic)
Water-gas shift	$CO + H_2O \rightarrow CO_2 + H_2$ (6)	-35.6 (exothermic)
Methane reforming	$CH_4 + H_2O \rightarrow CO + 3H_2$ (7)	+224.8 (endothermic)
Water-gas (i)	$C + H_2O \rightarrow CO + H_2$ (8)	+135.8 (endothermic)
Water-gas (ii)	$C + 2H_2O \rightarrow CO_2 + 2H_2$ (9)	+100.3 (endothermic)
Oxidation (i)	$C + O_2 \rightarrow CO_2$ (10)	-394.5 (exothermic)
Oxidation (ii)	$C + 0.5O_2 \rightarrow CO$ (11)	-111.5 (exothermic)
Boudouard	$C + CO_2 \rightarrow 2CO$ (12)	+171.4 (endothermic)
Methanation	$C + 2H_2 \rightarrow CH_4$ (13)	-88.9 (exothermic)

according to the physical and chemical processes characterised by each zone, which include temperature, air moisture, heat losses, mass flow rate of air and gas, solid phases, feed rate, feed size, and moisture content [115]. The following sub-section details the processes in each zone of a gasification system based on the operation of the fixed bed systems.

### 8.1. Drying zone

This zone lies at the top of the gasifier, and the material is fed into the reactor at this point. As the material descends down into the gasifier, particles are consumed in this zone. The main function of the drying zone is to drive off moisture in the material in the

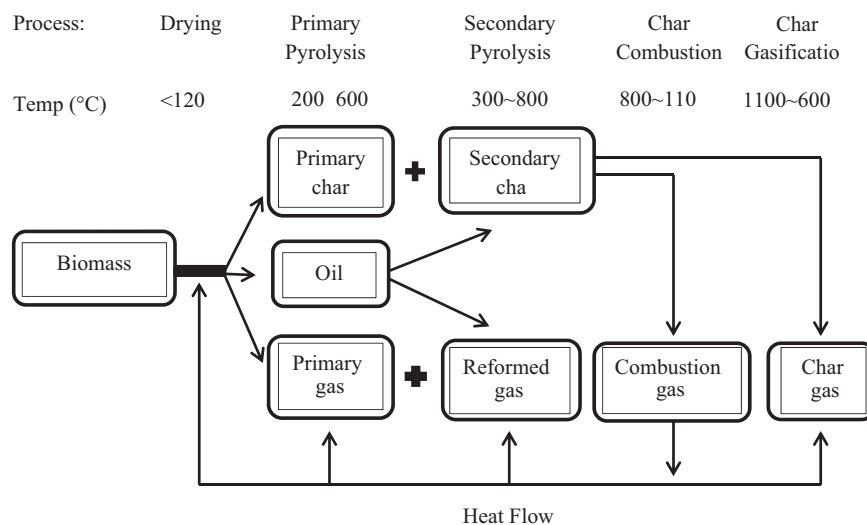

**Fig. 16.** Heat and mass flows in a gasification process [116]. With kind permission from Springer Science and Business Media.

form of water vapour. The heat necessary for this process is drawn from the pyrolysis and combustion zones of the gasifier [115]. The drying rate depends on the surface area of the material, temperature, velocity and relative humidity of the surrounding air as well as particles internal diffusivity, and this rate is governed by internal and external mass transfers [117]. The drying zone is characterised by a low temperature that is less than 120 °C, and heat transfer from this zone takes place by conduction from the material. The ability of the heat generated for drying to completely remove all the water from the material in this zone depends on the thermal conductivity of the material as some materials have low thermal conductivity [118].

### 8.2. Pyrolysis zone

This zone lies just below the drying zone with no air allowed in the zone during gasification. It draws heat from the surrounding oxidation zone. The material is initially broken down to tar, char and volatiles when heated in the absence of air between the temperature ranges of 200 °C and 600 °C. At a temperature of 250 °C, volatiles are released in a process known as primary pyrolysis where tar is generated near the surface. In this process, the tar generated is cracked at high temperatures (above 600 °C) into secondary char after escaping into a gas phase to form hydrocarbons such as methane [116,119]. This process is referred to as the secondary pyrolysis. In the pyrolysis zone, about 80–95% of the mass of the feed material for gasification is converted into liquid-phase products such as tar, oil, water, and gaseous phase products such as CO, H<sub>2</sub> and CO<sub>2</sub>, including hydrocarbons, with about 5–20% of reactive char remaining [120]. The composition and distribution of the products obtained at the pyrolysis stage of a gasification process depends on certain factors which includes feed composition, particle size, temperature and heating rate as well as the residence time of the gaseous components [117]. Char production also depends on the heating rate of the gasification process, and the lower the heating rate, the higher the production of char; at a low heating rate of 50 °C/min the reaction slowly breakdown the material, driving off carbon dioxide and water vapour in the process, and making the carbon content in the solid product higher than that in the feedstock [115]. The char and CO<sub>2</sub> produced in the pyrolysis zone then drifts down the oxidation zone for further reaction.

### 8.3. Oxidation zone

The oxidation zone, also known as the combustion zone, lies below the pyrolysis zone. It represents the zone through which oxygen is fed into the system to aid combustion. Oxygen in the form of input air reacts with the char produced in the pyrolysis zone, thus producing combustion gases such as CO<sub>2</sub> and H<sub>2</sub>O (water vapour). Char combustion is very rapid in this zone and results in a steep rise in temperature due to the exothermic nature of the reaction. The temperature in this zone is between 800–1100 °C, and the heat produced from the combustion of char is the main source of heat to other regions of the gasifier, while the hot combustion gas and water vapour produced in the combustion zone are drawn into the reduction zone [122]. Apart from heat generation, the combustion zone also serves to oxidise all condensable products from the pyrolysis zone. For these to be effectively achieved, temperature distribution must be uniform and cold spots avoided in the zone, which owes it to the gasifier geometry and the air inlet velocity [3,45].

### 8.4. Reduction zone

At the bottom of the downdraft gasifier lays the reduction zone.

The gasification process occurs as char reacts with carbon and steam to produce carbon monoxide and hydrogen. During this process only a small percentage of methane is formed due to the very high temperature in this zone which is not favourable for its formation. In this zone, hot gas temperature is also substantially reduced. An important consideration here is ash removal. If the ash were not removed continuously through the ash grate, ash would then build up inside the reduction zone and contaminate the reduction charcoal [120]. This would quickly lead to over-heating, which if not stopped in time could destroy the hearth. The automatic variable-speed ash grate prevents over-heating, provided it operates at the correct speed for a certain fuel; and the products of partial combustion (water, carbon dioxide and incombustible partially cracked pyrolysis products) now pass through a red-hot charcoal bed where reduction reactions take place [121]. The reactions here are endothermic, causing the temperature in the zone to decline from 1500 °C to about 600 °C [115].

## 9. Benefits of the gasification technology

Gasification technology has many great benefits, some of which have been highlighted in the following sub-sections.

### 9.1. Efficiency benefits

Gasification process efficiency is a major factor that influences the technical and economic viability of using the entire gasification technology for energy production; It is defined as the energy content of the product gas divided by the energy content of the gasification feedstock [45]. More economical electric power is an important benefit of higher process efficiencies [115]. In a typical biomass gasification power plant, heat from the plant can be converted into other forms of energy such as steam that drives a steam turbine/generator in addition to the syngas produced during gasification, which can also be used as fuel in stationary gas turbines for electricity generation. In gasification power plants, only about a third of the energy value of the feed material is actually converted; biomass gasification typically gets dual application from its product gases. The first application involves firing the product gases in a gas turbine, after being cleaned of impurities to generate one source of electricity. Secondly, some of the heat generated in the gasification process and the hot exhaust of the gas turbine are then used to generate steam for use in steam turbines/generators. This dual source of electricity generation is called a "combined cycle" which is considered a much more efficient way of converting the energy in biomass into usable energy [122].

### 9.2. Environmental benefits

The environmental benefits of biomass gasification stem from the ability of the technology to achieve extremely low concentrations of SO<sub>x</sub> and NO<sub>x</sub> together with reduced emission of particulates from combusting biomass-derived gases. Biomass materials including SCB generally exhibit low sulphur concentrations, which can be converted to hydrogen sulphide that can be captured by processes presently used in the chemical industry. In biomass gasification, the syngas produced is almost free of fuel-bound nitrogen with NO<sub>x</sub> from the gas turbine limited to thermal NO<sub>x</sub>, and advanced emission control processes to reduce NO<sub>x</sub> to as low as 2 ppm are being developed. These include multi-contaminant control processes to reduce pollutants to parts per billion levels which would be effective to clean up mercury and other trace elements, including metals [122]. Biomass gasification also



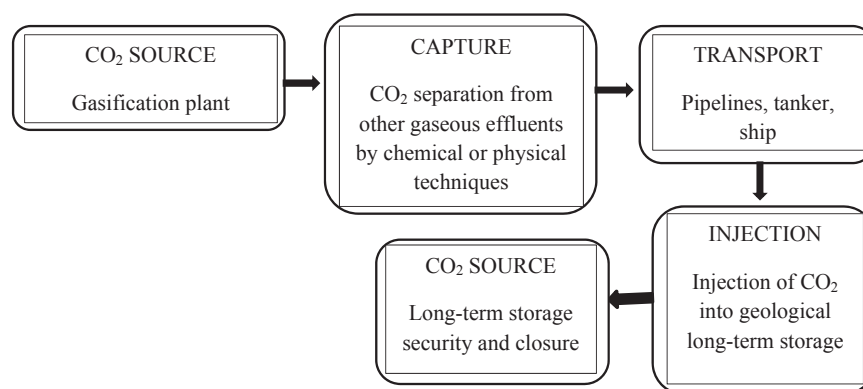

Fig. 17. The process of carbon capture, storage and utilisation. Used with permission from [124].

offers further environmental advantages in addressing the concern about atmospheric buildup of greenhouse gases (GHGs), such as carbon dioxide. If oxygen is used as the gasifying agent instead of air, the emission of CO<sub>2</sub> appears in the form of a concentrated gas stream in the syngas at high pressure, which can be captured and sequestered more easily at reduced costs. CO<sub>2</sub> capture, storage and utilisation is described in Section 10.5. If air is used as the gasifying agent, the CO<sub>2</sub> that results in the process appears diluted and as such, more expensive to separate [122].

### 9.3. Feedstock flexibility

Gasification systems have been developed to accommodate various types of feedstock, however, there is a need to understand gasifier operation to optimise the control of syngas properties based on feedstock variability. The feedstock flexibility of gasification technology arises from the ability of the process to thermochemically break down any carbon and hydrogen containing materials to a gas containing simple compounds that can be further processed into several products. In the case of the sugarcane industry in South Africa which generates large amounts of SCB as by-products, during sugarcane off crop season, the industry could potentially rely on the co-gasification of bagasse with coal as a means of overcoming the challenges of season limitation of bagasse if energy requirements of the industry are to be met. Both feedstocks (SCB and coal) are solid fuels and the equipment designed for bagasse combustion is also assumed to be able to use coal as well, and CO<sub>2</sub> emission should decline proportionally to the amount of coal offset by SCB [123].

Continuing research and development on feedstock pre-processing technologies and gasifier design remains the key to increasing adaptability of the gasification technology for any kind of feedstock. Research in this area is intended to minimise fuel costs for the gasification technology. Using more than one feedstock in a single facility reduces project risk and extends its lifespan [122]. However, there may be a need for the pre-processing of both feedstocks to make them suitable for gasification operations.

### 9.4. Product flexibility

The ability of the syngas produced to be further processed into high-energy dense products is a major advantage of the gasification technology. Liquid fuels such as diesel, gasoline and jet fuel as well as synthetic natural gas including hydrogen are some of the value-added products that can be obtained after further processing the syngas from the gasification of biomass [122]. A variety of fertilisers and other high-value chemicals which include naphtha, sulphur, phenol, anhydrous ammonia and ammonium sulphate can also be produced from further processing of the gasification

product syngas. About 45% of the syngas produced from biomass gasification worldwide is used in the production of chemicals and 28% for the production of liquid fuels, while 19% and 8% of world syngas production power are produced from power and gaseous fuels respectively [122].

### 9.5. Carbon capture, storage and utilisation

Carbon capture, storage and utilisation are a series of technological processes intended to mitigate GHG emissions. The process relies on the production of a concentrated stream of CO<sub>2</sub> that can be transported to a storage site [124]. Gasification of biomass lends itself to efficient CO<sub>2</sub> removal because of the high temperature and pressure associated with the product gas. CO<sub>2</sub> from a gasification plant can be captured and prevented from escaping into the atmosphere through either utilisation or storage. Two ways to achieve these are through sequestration, which involves injecting the CO<sub>2</sub> into deep geological formations for permanent storage; and through CO<sub>2</sub> enhanced oil recovery (CO<sub>2</sub> EOR), which relies on underground injection of CO<sub>2</sub> into mature oilfields to sweep residual oil, storing it in the process [124]. It occurs via four stages that are applicable in large centralised sources including gasification power plants [122,124]. Fig. 17 shows a simplified flow diagram of the stages involved in this process.

The first stage involves CO<sub>2</sub> capture from the gasification plant before it is transported to a suitable storage site for injection into deep geological formations where it is physically trapped below impermeable rocks [125]. It is of importance to monitor the CO<sub>2</sub> after injection to ensure it is permanently stored and remains safe for human health and the environment [124].

## 10. Types of gasification technologies

Since there must be interaction between the gasifying agent in a gasification process, in this case, air or oxygen, and the biomass material, gasifiers are classified according to the way the gasifying agent is introduced into the system [115,126]. Each type of gasifier is characterised by its own unique operational merits at a particular set of circumstances. The most common types are described in the following sub-sections.

### 10.1. The fixed-bed updraft or counter-current gasifier

In the updraft gasifier, the material is fed at the top of the gasifier and moves downward as it gets converted, i.e. the material for gasification move counter-current to the flow of the gasifying agent as it gets converted into syngas, hence this type of gasifier is also known as the counter-current type of gasifier. In moving

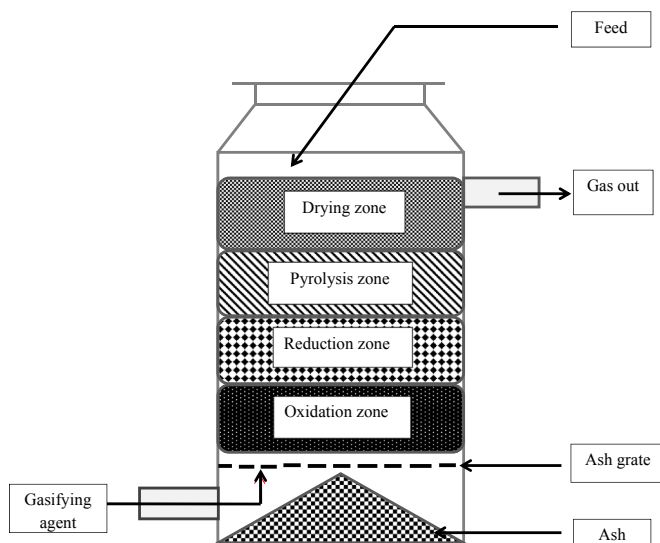

Fig. 18. Fixed bed updraft gasifier or counter-current gasifier. Reproduced with permission from [127].

counter-current to the gas flow, the material passes through the drying, pyrolysis, reduction and the oxidation zones. Fig. 18 shows a schematic representation of a typical updraft gasifier.

The fundamental chemical kinetics, with emphasis on the four main processes (drying, pyrolysis, oxidation and reduction) occurring in a gasification system have been given for each gasification technology based on the operation of the downdraft gasifier in Section 9, however, not much was mentioned about heat generation within the system for a typical updraft gasifier. In this type of gasifier, the heat for pyrolysis and drying is mainly supplied by the syngas which flows upward and partly by radiation from the oxidation zone. The oxidation zone lies just below the reduction zone in a typical updraft gasifier, where combustion reactions occur, followed by reduction reactions and the production of tar and volatiles which are carried in the gas stream [127]. The ash grate serves to allow ash generated in the process to be collected at the bottom of the gasifier, just below the oxidation zone. High charcoal burn-out, low gas exit temperatures as a result of internal heat exchange and high efficiency, as well as flexibility in feed-stock and ease of operation are among the advantages of the updraft gasifier [128]. Another advantage of this type of gasifier is the ability of the technology to tolerate feedstock with high moisture content, since the gasifying agent is introduced from the bottom of the gasifier and the gas exit is at the top of the gasifier. This allows for high rate of heat transfer as the hot gas from the oxidation zone of the gasifier interacts with the biomass material, drying the material on its way out [45]. However, the major limitations of using the updraft gasifier are the excessive amount of tar produced in the syngas and poor capability of loading as well as issues related to channelling in the equipment which can lead to explosive situations as a result of breakthrough in oxygen [127].

### 10.2. The fixed-bed downdraft or co-current gasifier

A solution to the problem of tar entrainment experienced by other types of gasifiers was addressed through the design of the downdraft gasifier in which the gasifying agent is introduced at or above the oxidation zone of the gasifier. Downdraft gasifiers are similar to updraft gasifiers, except that the zones are located in reverse order, where pyrolysis products pass through the high temperature oxidation zone and undergo further decomposition into combustion products [127]. A schematic of a typical downdraft gasifier is presented in Fig. 19.

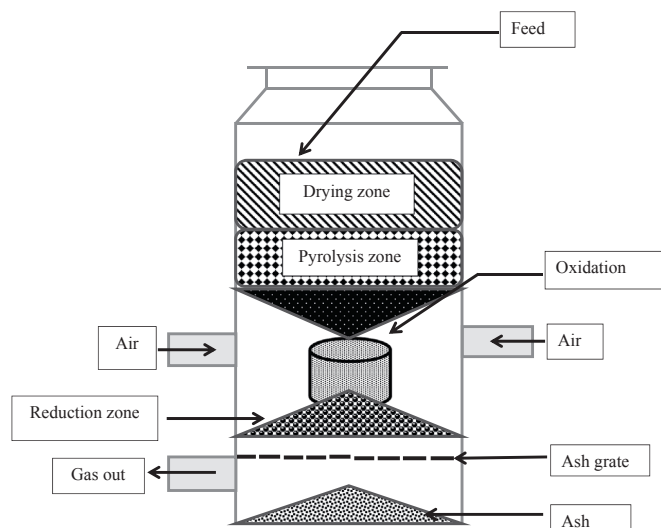

Fig. 19. Fixed bed downdraft or co-current gasifier. Reproduced with permission from [127].

Dehydration, as a consequence of moisture evaporation occurs in the drying zone of the gasifier, and the evaporated moisture serves as a reaction agent during gasification. The product gas exits from the bottom of the gasifier, and contains significantly less amount of tar, compared to the updraft gasifier with high quantities of tar in the product gas. As a result of this the need of gas cleaning reduces, and therefore leaves the gas suitable for a wide variety of applications. Depending on the temperature of the oxidation zone, tar and pyrolysis products from the feed pass through a glowing bed of charcoal and are converted into a gas containing CO, H<sub>2</sub> and CO<sub>2</sub> CH<sub>4</sub> [115].

The major advantages of the downdraft gasifier stem from its low tar production rate (most of the tar produced is disintegrated in the high-temperature oxidation zone of the gasifier, low entrainment of particulate matter, low capital, operational cost and its simplicity and ease of operation. The downdraft gasifier design has simple and easy control systems when compared to other types of gasifiers with expensive and complicated control systems such as the fluidised bed, the entrained flow and the plasma gasification systems described in Sections 10.4, 10.5 and 10.6 respectively. The wear rate of the downdraft gasifier is minimal; as a result, the maintenance cost is low [129]. Its major disadvantage lies in its difficulty to handle feed with high moisture and ash contents, and its inability to operate on a number of unprocessed fuels. Lack of internal heat exchange and lower heating value of the product gas from a downdraft gasifier are also some of the minor drawbacks of the system when compared with the updraft system [130]. As with most gasification systems, another major drawback of the downdraft gasifier is the inability of scale-up. The downdraft gasifier cannot be developed on a large scale (maximum thermal and power outputs are approximately 1300 kW<sub>th</sub> and 400 kVA respectively) due to non-uniform heat distribution within its oxidation zone, which also has been attributed to its design characteristics, however the time required to ignite and bring the plant to a working temperature is approximately 20–30 min, which is quite shorter than that required for the updraft gasifier [45].

### 10.3. The fixed-bed crossdraft gasifier

The fixed bed crossdraft gasifier exhibits many of the operating features of the downdraft gasifier. The gasifying agent is introduced from the side near the bottom, while the product gas

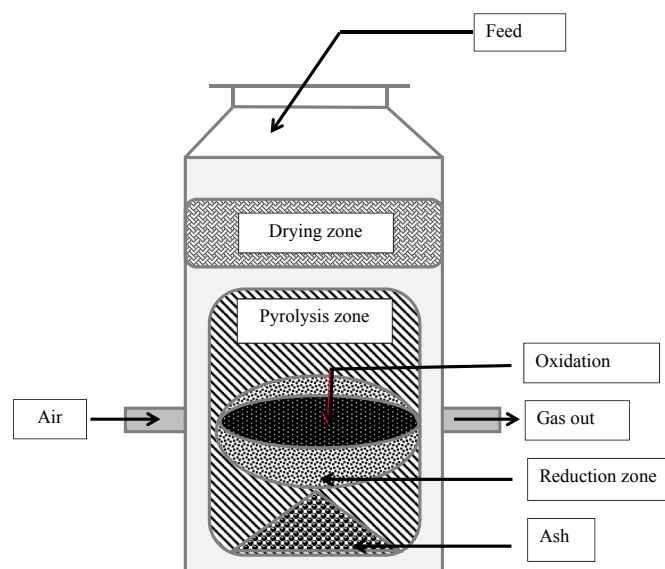

**Fig. 20.** A schematic diagram of a crossdraft gasifier. Reproduced with permission from [127].

exits from the opposite side of the system. The ash bin and the oxidation zone as well as the reduction zone in a crossdraft gasifier are separated from each other, unlike the updraft and the downdraft type of gasifiers. Due to this design characteristic, the type of feedstock for gasification is limited to low ash materials such as wood and charcoal [127]. A schematic representation of this type of gasifier is shown in Fig. 20.

Concentrated partial zones operating at a temperature as high as 2000 °C makes the load following abilities of the crossdraft gasifier suitable for gasification of low-ash feed materials [131]. Startup time is about 5–10 min, which is much faster when compared to other types of gasifiers such as the updraft or the downdraft gasifiers. However, this type of gasifier (crossdraft) has disadvantages in terms of its exit gas temperature and gas velocity, which are usually high, and also its poor reduction in CO<sub>2</sub>. These shortcomings are a consequence of its design, however the choice of one gasifier type over the other is dictated by a number of factors including the feedstock for gasification and the final available form of the feedstock, i.e. its size, moisture and ash contents among other factors [127].

#### 10.4. The fluidised bed gasifier

Fluidised bed gasifiers were originally developed to overcome operational challenges associated with fixed bed gasification systems. This type of gasifiers have no distinct reaction zones compared to the fixed bed systems as drying, pyrolysis and gasification occur simultaneously, with a relatively low gasification temperature which is approximately 750–900 °C [127]. They are made of chemically unreactive materials such as ash, sand or charcoal that acts as a heat transfer medium. A schematic representation of the fluidised bed gasification system is shown in Fig. 21.

In the fluidised bed gasification system, the gasifying agent is blown through a bed of solid particles which has been pre-heated to a set temperature. The feedstock for gasification is introduced at the set bed temperature which is high enough for ignition. The gasifying agent is blown through a distributor plate at a controlled rate, allowing the material to undergo fast pyrolysis, giving rise to a component mixture of gaseous materials. Further reactions related to tar-conversion reactions occur in this gaseous mixture. The high quantities of tar generated in this process are not completely disintegrated because of the low temperatures of the

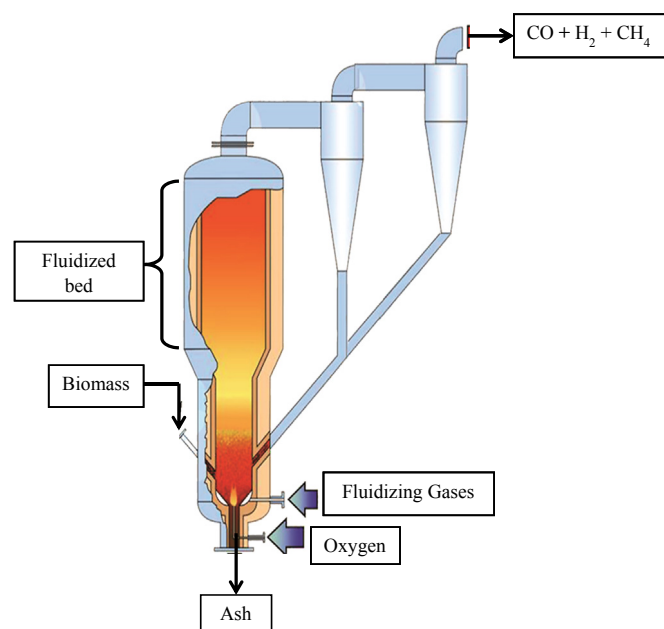

**Fig. 21.** Schematic diagram of a fluidised bed gasifier. Reproduced with permission from [132].

fluidised bed systems [127]. Char blow-out are minimised as much as possible because the fluidised bed gasifier, as with most gasification systems, is equipped with a cyclone.

A major advantage of the fluidised bed gasifier stems from its high rate of heat and mass transfer as well as excellent gas to solid contact including excellent heat transfer characteristics. Other advantages include good temperature control, flexibility in feedstock, co-feeding tendencies, large heat storage capacity, and a good degree of mixing [132]. In the light of these advantages, several shortcomings can also be encountered when fluidised bed gasification systems are used. These includes high tar content of the syngas produced (500 mg/m<sup>3</sup> gas), poor response to changes in load and incomplete carbon burn-out as well as the possibility of scale-up which is very minimal [127]. High capital and operational costs as well as complicated and expensive control systems are also some of the limitations of using this type of gasifier. Fluidised bed gasifiers operate at pressures slightly above the atmospheric pressure, which requires that leaks of any sort be avoided. These drawbacks have limited the widespread deployment of these systems for energy production purposes.

#### 10.5. The entrained flow gasifier

The entrained flow gasification systems are characterised by fuel particles that are dragged along with the gas stream at high temperatures typically between 1300 and 1500 °C; they are also characterised by short residence times and small fuel particles (typically < 100 μm), and operate under pressure with pure oxygen, with capacity often in the order of several hundreds of megawatts (MW) [133]. Fig. 22 shows a sketch of the entrained flow gasifier.

Materials for gasification using the entrained flow systems are generally introduced into the gasifier by pneumatic feeding systems after pressurising the system. The gasifying agent mostly employed is oxygen, which is co-currently fed into the gasifier with the feedstock, resulting in the oxidant entraining the material as it flows through the gasifier. High temperature and pressure as well as extremely unstable flow are characteristics of entrained flow gasification systems. These result in high throughput and rapid feed conversion, with gasification reactions occurring at a

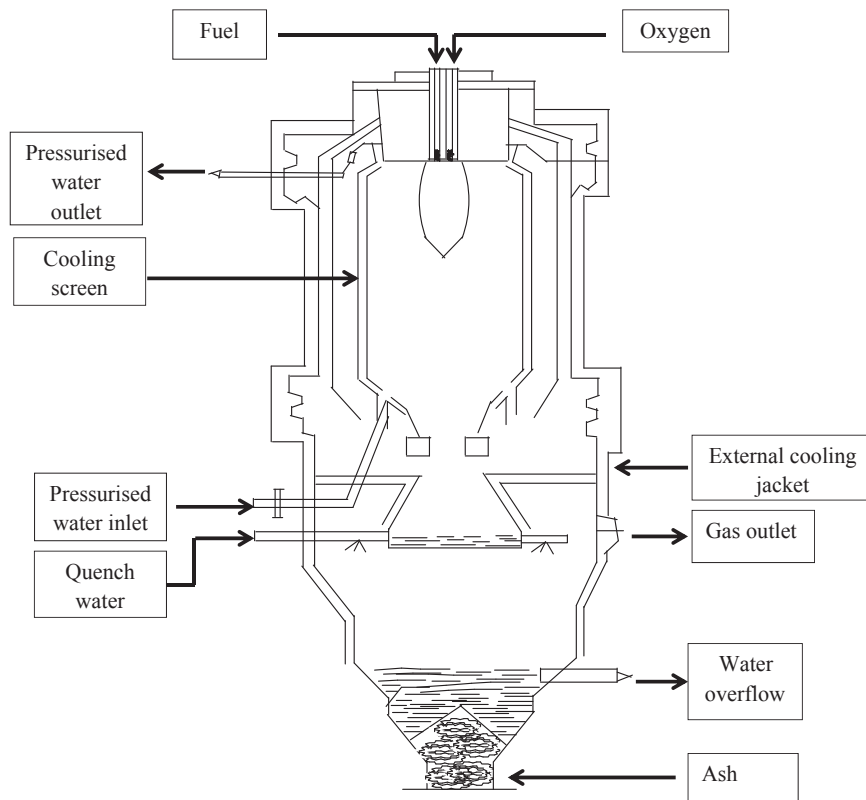

Fig. 22. Schematic diagram of an entrained flow gasifier [134].

high rate, allowing for high carbon conversion efficiencies in the range 98–99.5%. The residence time of the entrained flow gasifier is relatively low (in the order of few s), hence it operates at high temperature to achieve high carbon conversion efficiencies. The polyaromatic hydrocarbon compounds such as tar, phenols and other liquid compounds produced from the devolatilisation of the feedstock are decomposed into a mixture of gases containing CO, H<sub>2</sub> and trace amounts of light gases with similar properties to the hydrocarbons. The major advantage of the entrained flow gasifier lies in its ability to handle a variety of feedstock that can be fed into the gasifier in dry or slurry form, producing a clean, tar-free syngas. A simpler operation of the gasifier involves the slurry feed, but this introduces water into the gasifier, which needs to be evaporated to ensure optimum efficiency; the addition of water results in a product gas with higher ratio of H<sub>2</sub> to CO, and a reduced thermal efficiency. This remains one of the limitations of using the entrained flow gasifiers for the gasification of biomass materials such as SCB. Another issue with the entrained flow gasifier is the high temperatures involved, which tend to increase wear rate by shortening the life span of the components of the gasifier, including refractory lines because at high gasification temperatures, ash changes to the three states of matter (liquid, gas and solid states), wearing down refractory materials and causing fouling which can also lead to unplanned plant shutdown for repairs [135].

#### 10.6. The plasma gasifier

The plasma gasification technology uses a plasma technology to convert any organic matter into syngas in oxygen-deficient environment. In this type of gasifier, wastes are not combusted as they are in incinerators; instead, they are converted through an ionised gas (a gas containing free flowing electrons that give positive and negative charges to atoms, thus becoming a highly efficient conductors of electricity and generator of heat in the

process) into a fuel gas that still contains the entire chemical and heat energy from the waste; this process employs a plasma torch that is powered by an electric arc to ionise gas and catalyse the organic material into syngas. Plasma gasifiers are commercially used as a form of waste treatment, and have, however also been tested for the gasification of biomass and solid hydrocarbons such as coal [134]. Fig. 23 presents a schematic of a typical plasma gasification system showing its main components.

Plasma gasification takes place under high temperatures, typically above 6000 °C, and the process is driven by a plasma torch system which is located at the bottom of the gasifier. The feedstock is broken down into its constituent elements and dramatically increasing the kinetics of the various reactions occurring in the gasification zone, converting all organic materials into carbon monoxide (CO) and hydrogen (H<sub>2</sub>) in the process. Any residual material of inorganic and heavy metals will be melted and produced as a vitrified slag which is highly resistant to leaching [134]. Fig. 24 shows the components of a plasma gasifier torch and illustrates how the torch operates during gasification.

The plasma gasifier torch has two electrodes which creates an arc as electricity is fed to the torch. The process gas is heated to an internal temperature as high as approximately 14,000 °C as inert gas is passed through the arc-forming electrodes. The temperature close to the torch can be as high as 2760 °C to approximately 4500 °C, and due to these high temperatures, the waste is completely broken down into its basic elemental components [134]. There are no polyaromatic hydrocarbons (such as tar), and heterocyclic organic compounds (such as furan) formed during plasma gasification because of high temperatures associated with the process. All metals become molten and flow out through the bottom of the reactor. Inorganic materials such as silica, soil, concrete, gravel, glass, etc. are converted into glass; no ash is formed at these high temperatures [136]. A process flow diagram for plasma gasification is presented in Fig. 25.

The feedstock (usually organic waste) is delivered into the feed

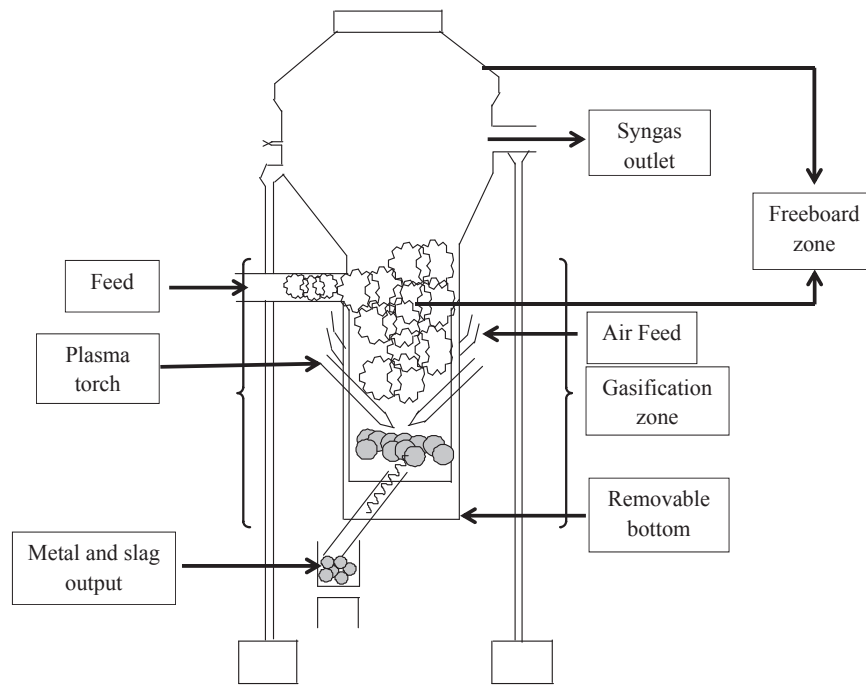

Fig. 23. A schematic diagram of a plasma gasifier [134].

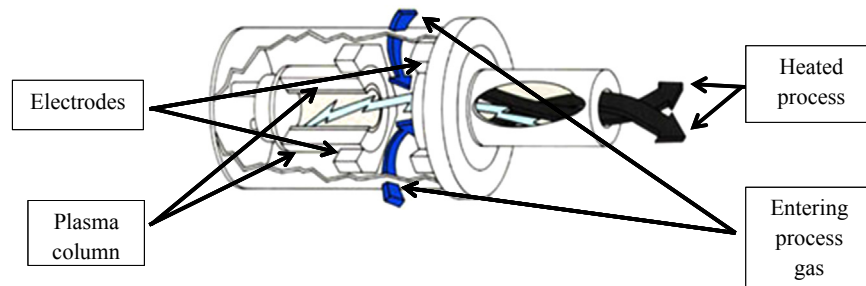

Fig. 24. A plasma gasifier torch [129].

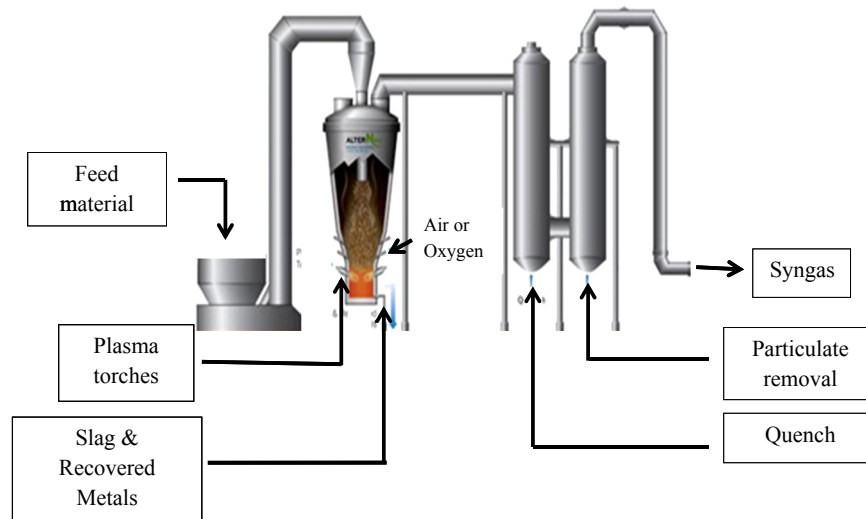

Fig. 25. The plasma gasification process [137]. Reproduced with permission from Phoenix Energy Australia Pty Ltd.

system and made to pass through an air-tight system which prevents gases escaping into the atmosphere. The plasma torches function to provide part of the heat needed to drive the endothermic gasification reactions. The torches are powered by an automatic control system that adjusts the gasification conditions

to accommodate potentially highly variable nature of the feed material [137]. The plasma arc is embedded in the plasma torch and as a result, the waste material is not directly exposed to the plasma arc, hence the classification of the process as plasma induced gasification. The main advantage of plasma gasification

includes non-discrimination between types of wastes for gasification. It can take virtually any type of waste, enabling the waste material to be used as fuel without the need for pulverising; no prior sorting of the waste is necessary [134]. However, the major drawbacks hindering the widespread use of this type of gasification technology at both laboratory-and pilot-scale include its high capital and operational costs together with the highly corrosive nature of the plasma flame. The latter arises as a result of bombardment by hot species from the flame, which may lead to frequent maintenance and replacement of components, resulting in intermittent shutdowns, including the production of toxic compounds due to embedded filters and gas treatment systems which are sources of toxic materials [136]. There is also limited information in the literature on studies dealing with modelling and simulation of gasification processes involving plasma gasifiers. Overall, plasma gasification is not well suited for the gasification of SCB because of the extremely high temperature of the process [134].

### 11. The choice of gasifier for sugarcane bagasse gasification

All types of gasifiers described in Section 11 can produce syngas for combustion purposes, with each designed for specific types of feedstock. However, gasifier efficiency remains an important factor that determines the technical operation as well as the economic viability of using a gasifier system [138]. Among other factors, the efficiency and effectiveness of these gasifiers is dependent upon the type and design of the gasifier [139]. Fluidised bed systems have been known to achieve higher efficiencies than other types of gasifiers but are not preferred for bagasse conversion for the purpose of electricity generation because of their high capital and operational costs as well as their high tar production rate; the production of tar creates major operational challenges such as clogging in engine valves resulting in high maintenance costs due to processes involved in tar removal [140]. Fluidised bed gasifiers are also known to have complex and expensive control systems when compared to other types of gasifiers, which limits their laboratory or large scale applications. Among the fixed bed systems, updraft gasifiers are more efficient but suffer from excess amount of tar in the product syngas which is not suitable for gas engines or turbines. Poor loading capabilities and breakthroughs in O<sub>2</sub> due to poor channeling (a situation prone to explosion) are also issues related to the use of this type of reactors; however downdraft gasifiers are preferred for the gasification of SCB or any other type of biomass material for the purpose of electricity generation because of their low entrainment of tar and particulates, which are characteristics of their design [136]. They are the most commonly used type of gasifier due to their low capital and operational costs, and due also to their simplicity and ease of operation combined with high process efficiency, with minimal wear and tear rate that results in low maintenance cost in comparison to other types of gasifiers [45]. Crossdraft gasifiers are also a type of fixed bed gasifiers that are efficient and effective. As previously stated, although they exhibit many of the operating characteristics of the downdraft system, they are not well suited for the conversion of biomass materials such as SCB for electricity and/or heat generation purposes because of their high sensitivity to the formation of slag and high pressure drops [128]. Entrained flow gasification systems are not common like the other types of gasifiers, but are also known to be efficient. A major limitation in the use of this type of gasifier, as previously mentioned, lies in the high temperatures involved, which tends to increase wear rate, making intermittent repairs unavoidable as a consequence of fouling. Plasma gasifiers are also not in widespread use because of their expensive nature and extremely high temperature as well as

because of the highly corrosive nature of the plasma flame which are a source of toxic compounds [136].

Based on the aforementioned technical and economic drawbacks on the use of other types of gasifier for the conversion of SCB into energy, the downdraft gasifier appears to be the most suitable gasification system due to its simplicity and ease of operation. However, as stated earlier, its only difficulty lies in its inability to handle feed with relatively high moisture and ash contents, and its inability to operate on a number of unprocessed fuels, which simply requires that pre-processing of the feedstock for gasification be undertaken to achieve the needed gasification process efficiency.

### 12. Influence of gasifier design on the gasification process of sugarcane bagasse

Gasifiers are designed in accordance with feedstock properties requirements, with each having its own unique operational advantages at a particular set of circumstances. This indicates large differences in the way gasifiers are designed including dimensions, material feeding point, reactor geometry, throat angle and throat diameter (in the case of downdraft gasifiers), etc. The influence of these design parameters on both input and output parameters during gasification of biomass cannot be overstated. They ultimately influence parameters not limited to syngas composition, calorific value and process efficiency. These parameters favour the gasification process of biomass including SCB under standard design parameters as well as under various gasifier operating conditions, regardless of the type of biomass material used as feedstock; these design parameters were tested when Hanaoka et al. [141] worked on 12 different types of biomass and found that syngas production increased with increasing feed volatile matter content under standard gasifier design parameters, regardless of feedstock variety. A study also conducted by Anukam et al. [3] on the simulated gasification process of SCB in a downdraft system proved that process efficiency, gasification rate and syngas heating value were all affected by certain gasifier design parameters such as throat angle and throat diameter. They concluded that efficiency improved upon employing gasification systems with smaller throat angles and throat diameters. Akay and Jordan [54] also performed an experimental study on the gasification of fuel cane bagasse (FCB) in a downdraft gasifier and reported that optimum efficiency obtained for the gasification process was as a consequence of free fuel flow down the combustion zone through the narrow throat of the gasifier due to sized fuel particle, which facilitated faster rates of heat transfer and rapid gasification reactions. According to Kaupp and Goss [53], to avoid bridging during gasification of biomass and to improve efficiency, the ratio of the throat diameter to the maximum diameter of the fuel should be at least 6.8:1. In another study conducted by Corella et al. [142] on the gasification of biomass using a fluidised bed reactor with an internal diameter of 60 mm, the effect of feeding point location was reported and it was concluded that the fluidised bed system used in their study suffered from poor bed material mixing under tested fluidisation conditions because of high char yield when the biomass was fed at the top of the gasifier, compared to feeding at the bottom. They further concluded that high char yield was as a result of segregation of the conversion products in the bed, which acted to restrict further chemical reactions between the char and volatiles from the material, adding that gasifier design also influenced the residence time of the product syngas.

### 13. The chemistry of sugarcane bagasse gasification

This section describes the reaction mechanism involved in the

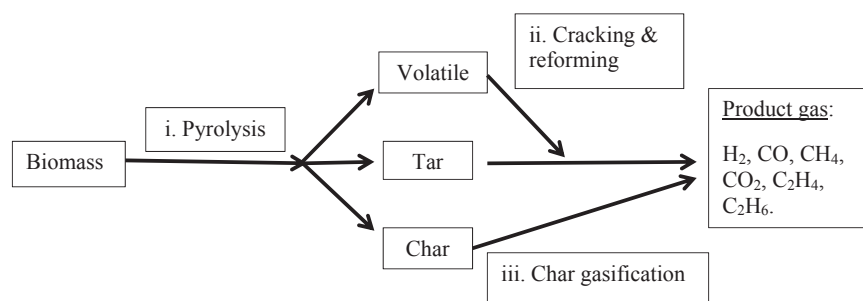

Fig. 26. General reaction mechanism and product distribution of the gasification process of biomass. Reproduced with permission by Elsevier from [143].

conversion of SCB to facilitate an understanding of the chemistry involved in its gasification process.

Clearly, as described in Section 8.1, there are no chemical reactions taking place in the drying zone of a gasification process employing the downdraft system due to the low temperature associated with this zone. However, material degradation occurs in the pyrolysis zone due to higher temperatures in this zone. A simplified general reaction mechanism for the gasification of biomass is given in Fig. 26.

The process in Fig. 26 involves three main steps that are distinguished by reaction temperature. The first step involves devolatilisation which occurs in the temperature range of 300 and 500 °C. At this temperature, 70–90% of the material is converted to volatile matter and solid char, while the second step incorporates tar cracking and reforming reactions, which occur at a temperature above 600 °C; this dominates reaction processes by influencing the final composition of the product syngas during gasification [144]. The tar is typically the condensable organic matter with molecular weights greater than benzene [145,146]. The last step of the gasification process incorporates char gasification reactions which occurs at high temperatures greater than 800 °C. Table 6 provides a series of complex reactions that includes gas-solid reactions between particles of the biomass material and the gasification medium (gasifying agent), which are a result of the reaction mechanism presented in Fig. 26.

Tar and volatile matter cracking are due to low temperature regions of the gasification process which are usually < 700 °C, and are therefore represented by Eq. (5) in Table 6, while Eq. (6), the prominent water-gas shift reaction in the gasification process of biomass remains the most dominant of the reactions due to high temperatures under which the reaction occurs (> 700 °C), and which, to a large extent, determines the final composition of the product gas [149]. The final product composition of a gasification process can be manipulated by controlling the reaction parameters, including the temperature of gasification and the ratio of the gasifying agent to that of the material [150]. The impact of these reaction parameters is to, amongst other things, enhance biomass conversion to the desired product gas. Tar concentration greater than 3 g/Nm<sup>3</sup> in the product gas can cause significant problems in gasification systems as well as in gas engines because it leads to blockage of valves and other engine components, resulting in shutdowns; however, tar destruction leads to a higher gas yield [151–154]. A solution to the problem of tar entrainment during gasification is addressed when the biomass material for conversion is taken through efficient and effective pre-processing steps to lower the concentration of tar forming elements such as carbon, hydrogen and oxygen as well as nitrogen and sulphur; these elements react at different stages of the gasification process depending on the reaction conditions of the process [140]. The properties of gasification by-products such as tar depend strongly on the feedstock properties and the type of gasifier used [155].

## 14. Summary

A summary of the comparison of the advantages and disadvantages of various pre-processing methods for sugarcane bagasse for the purpose of gasification are shown in Table 7. This is presented to have a clearer view of the best pre-processing method for sugarcane bagasse intended for gasification purposes.

The efficiency and effectiveness of a particular pre-processing method are usually linked to the advantages and disadvantages associated with each method, which in turn are also used as key indicators to determine the technical and economic viability of the pre-processing method [156]. However, it is quite evident from Table 7 that, of all the pre-processing methods described in this review, torrefaction appears to be a more reliable method than other pre-processing methods because of its limited disadvantages such as low volumetric energy density of the torrefied material, which can be compensated for by densifying the torrefied material, hence most studies dealing with biomass pre-processing for gasification purposes recommends a combination of torrefaction and densification since both methods address each other's drawbacks. The reduced power consumption of torrefaction also makes it a better choice for sugarcane bagasse pre-processing compared to other pre-processing methods since the process does not negatively affect material composition and improve its grinding properties for better gasification.

A summary of the comparison of the various types of gasifiers in terms of the advantages and disadvantages associated with each of them are also presented in Table 8. This is presented for the same reason previously adduced for the pre-processing methods.

## 15. Conclusions

The pre-processing of SCB for gasification has been comprehensively reviewed together with various gasification systems for its conversion into energy. It can be noted that pre-processing plays a very significant role in the gasification process of SCB when employing the downdraft gasification system, and remains a key bottleneck in the efficient utilisation of bagasse for energy production. Pre-processing is intended to overcome the limitations of efficiently using SCB for the purpose of energy production and also decrease the release of soil and water pollutants which may be produced due to elemental composition of bagasse. The pre-processing methods reviewed showed that the shortcomings of one method can be compensated for by other methods, since the methods seem to be complementary in their limitations and advantages. This also applies to the gasification systems comprehensively reviewed. However, among all pre-processing methods reviewed, torrefaction was identified as the most efficient and effective method considering its advantages over the other methods. Process variables such as temperature, pressure, time of retention play a major role in the quality attributes of a pre-

**Table 7**  
A comparison of the advantages and disadvantages of various pre-processing methods. Reproduced with permission from [35].

Pre-processing method	Advantages	Disadvantages
Size reduction	<ul style="list-style-type: none"> <li>Basic method that brings the feedstock to the size required by the gasification technology specification</li> </ul>	<ul style="list-style-type: none"> <li>Storage of the sized material can increase microbial activity and dry matter losses</li> <li>Storage of the material can be a source of significant emissions of GHG (CH<sub>4</sub>, N<sub>2</sub>O), due to microbial activities</li> </ul>
Drying	<ul style="list-style-type: none"> <li>Reduces loss of dry matter during storage of bagasse</li> <li>Reduces the risk of self-ignition and material decomposition</li> <li>Reduces fungal development and activity during storage</li> <li>Increases material's ignition ability and potential energy input during gasification</li> </ul>	<ul style="list-style-type: none"> <li>Non-friable character of bagasse can cause problems during sizing</li> <li>Natural drying is commonly applied, however, it has a disadvantage of unforeseeable weather conditions</li> <li>Drying using dryers require sized material which can constitute a problem due to non-friable character of bagasse</li> </ul>
Pelletising	<ul style="list-style-type: none"> <li>Higher energy density with transportation cost benefits</li> <li>Permits automatic handling and feeding during thermal conversion</li> <li>Require less storage space</li> <li>Dry feedstock with good storage properties, reduced health risk, reduced energy losses and higher calorific value</li> </ul>	<ul style="list-style-type: none"> <li>Despite benefits, pellets can be sensitive to mechanical damaging and can absorb moisture, swell, loose shape and consistency</li> <li>Specific storage environment is required for safe and efficient storage</li> </ul>
Briquetting	<ul style="list-style-type: none"> <li>Higher energy density with possibility for more efficient transportation</li> <li>Require less storage space</li> <li>Reduces the possibility of spontaneous combustion during storage</li> <li>Allows for gravity feeding in the gasifier during gasification</li> <li>Combustion rate can be compared with coal</li> </ul>	<ul style="list-style-type: none"> <li>Easy moisture uptake which may lead to biological degradation and loss of structure</li> <li>Briquettes require special storage conditions</li> <li>Hydrophobic agents can be added to the process of briquetting, but this leads to significant increase in cost</li> </ul>
Torrefaction	<ul style="list-style-type: none"> <li>Improved hydrophobic nature-easy and safe storage with reduced biological degradation</li> <li>Power consumption during sizing is reduced due to improved grinding properties of the torrefied material</li> <li>Increased uniformity and durability</li> </ul>	<ul style="list-style-type: none"> <li>Results in low volumetric energy density</li> </ul>

processed SCB. Therefore, it would be recommended to study the influence of pre-processing on other gasification process conditions (such as syngas composition and yield). More fundamental studies need to be undertaken to better understand how pre-processing impacts on SCB both on a molecular and structural level, and how these affect its gasification process. There is also a need for studies to be conducted on the impact of pre-processing

upon the concentration of trace elements in bagasse and how the gasification process is also affected by these elements as some trace elements can negatively influence the process even at very low concentrations. In addition, considering the fact that most renewable energy resources lack the ability to deploy the power generated to meet demand at any given time and need to be supported by storage facilities or facilities that use fossilised

**Table 8**  
A comparison of the advantages and disadvantages of various gasifiers [127–129,137].

Type of gasifier	Advantages	Disadvantages
Updraft	<ul style="list-style-type: none"> <li>Small pressure drops</li> <li>Good thermal efficiency</li> <li>Little tendency towards the formation of slag</li> </ul>	<ul style="list-style-type: none"> <li>High sensitivity to tar and fuel moisture content</li> <li>Startup of internal combustion (IC) engine require relatively long time</li> <li>Poor reaction capability with heavy gas loads</li> </ul>
Downdraft	<ul style="list-style-type: none"> <li>Flexible adaptation of gas production to loads</li> <li>Low sensitivity to charcoal dust and tar content of fuel</li> <li>Low entrainment of particulates</li> <li>Simple and easy control systems</li> <li>Simplicity and ease of operation</li> <li>Wear rate is minimal, as a result, maintenance cost is reduced</li> </ul>	<ul style="list-style-type: none"> <li>Design tends to be tall</li> <li>Not feasible for very small particle size of fuel (size requirement relatively strict)</li> <li>Only limited to small-scale applications (scale-up not feasible)</li> <li>Unable to handle feedstock with high moisture and ash contents</li> <li>Inability to operate on a number of unprocessed feedstocks</li> </ul>
Crossdraft	<ul style="list-style-type: none"> <li>Short design height</li> <li>Very fast response time to load</li> <li>Flexible gas production</li> </ul>	<ul style="list-style-type: none"> <li>Highly sensitive to slag formation</li> <li>High pressure drops</li> <li>Poor reduction in CO<sub>2</sub></li> <li>Limited to low ash materials such as wood and charcoal</li> </ul>
Fluidised bed	<ul style="list-style-type: none"> <li>Excellent gas to solid contact</li> <li>Excellent heat transfer characteristics</li> <li>High rates of heat and mass transfer</li> <li>Good temperature control</li> <li>Large heat storage capacity</li> <li>Good degree of mixing</li> </ul>	<ul style="list-style-type: none"> <li>Increased tar production rate</li> <li>Poor response to changes in load</li> <li>Incomplete carbon burn-out</li> <li>Possibility of scale-up is minimal</li> <li>Complicated and expensive control systems</li> <li>High capital and operational costs</li> </ul>
Entrained flow	<ul style="list-style-type: none"> <li>High throughput and rapid feed conversion as a consequence of the high temperature and pressure characterised by the process</li> <li>Feedstock can be fed in dry or slurry form</li> </ul>	<ul style="list-style-type: none"> <li>Water is introduced into the gasifier due to slurry feedstock, which results in reduced thermal efficiency</li> <li>High temperature increases wear rate</li> <li>Highly corrosive nature of the plasma flame</li> </ul>
Plasma	<ul style="list-style-type: none"> <li>Does not discriminate between types of waste for gasification</li> <li>Does not require prior sorting of the waste for gasification</li> <li>No need for pulverising</li> </ul>	<ul style="list-style-type: none"> <li>Extremely high temperature of the process leads to high wear rates</li> <li>Production of toxic compounds due to embedded filters and gas treatment systems</li> <li>High capital and operational costs</li> </ul>



resources, there is a need for an investigation to be undertaken on where the energy required for pre-processing would emanate from, and how this energy would balance with that produced during gasification.

Pre-processing difficulties for a dedicated heat and power plant using SCB as feedstock can be addressed when the pre-processing methods and their effects are well-understood. The technical and economic viability as a consequence of its design characteristics makes the downdraft gasifier well suited for the gasification of SCB.

## Acknowledgements

The authors wish to thank the National Research Foundation (NRF)-Sasol Inzalo Foundation (SIF) (Grant number 95584), the Fort Hare Institute of Technology (FHIT) (Grant number P822) and the Govan Mbeki Research and Development Centre (GMRDC) (Grant number P755) as well as the Chemistry Department of the University of Fort Hare( Grant number D154) for their financial supports.

## References

- Pandey A, Soccol CR, Nigam P, Soccol VT. Biotechnological potential of agro-industrial residues. I: sugarcane bagasse. *Bioresour Technol* 2000;74:69–80.
- Reddy MR, Chandrasekhariah M, Govindaiah T, Reddy GVN. Effect of physical processing on the nutritive value of sugarcane bagasse in goats and sheep. *Small Rumin Res* 1993;10:25–31.
- Anukam A, Mamphweli S, Meyer E, Okoh O. Computer simulation of the mass and energy balance during gasification of sugarcane bagasse. *J Energy* 2014 [Article ID 713054].
- Walford S. Sugarcane bagasse: how easy is it to measure its constituents? In: *Proceedings of the South African Sugar Technologists Association*. Vol. 81; 2008. p. 266–73.
- McKendry P. Energy production from biomass (part 1): overview of biomass. *Bio-Resour Technol* 2002;83:37–46.
- Ramjeawon T. Life cycle assessment of electricity generation from bagasse in Mauritius. *J Clean Prod* 2008;16:1727–34.
- Deepchand K. The role of regulators in a reforming power sector in sub-saharan Africa. *ESI Afr J* 2004(Issue 2):.
- Demirbas FM. Biorefineries for biofuel upgrading: a critical review. *Appl Energy* 2009;86:5151–61.
- Agbor VB, Cicek N, Sparling R, Berlin A, Levin DB. Biomass pretreatment: fundamentals toward application. *Biotechnol Adv* 2011;29:675–85.
- United States Department of Energy. Gasification technology research and development. (<http://energy.gov/fe/science-innovation/clean-coal-research/gasification>). [last accessed, January 2014].
- Slopiecka K, Bartocci P, Fantozzi F. Thermogravimetric analysis and kinetic study of poplar wood pyrolysis. *Appl Energy* 2012;97:491–7.
- Johannes T. Pyrolysis of sugarcane bagasse. Masters dissertation. University of Stellenbosch; 2010.
- South African Sugar Association. Sugarcane crushed by mills. Facts and Figures. ([http://www.sasa.org.za/sugar\\_industry/FactsandFigures.aspx](http://www.sasa.org.za/sugar_industry/FactsandFigures.aspx)); 2014 [last accessed February 2015].
- Rocha CJM, Gonçalves AR, Oliveira BR, Olivares EG, Rossell CEV. Steam explosion pretreatment reproduction and alkaline delignification reactions performed on a pilot scale with sugarcane bagasse for bioethanol production. *Ind Crops Prod* 2012;35(1):274–9.
- Lewis C. The South African Sugar Industry. Geography Department, Rhodes University; 2004.
- AXA Bharti General Insurance Company Limited. Lead article: Loss prevention in sugar industries. A quarterly loss prevention digest. 10th ed.; May 2013.
- Kinoshita CM. Co-generation in the Hawaiian sugar industry. *Bioresour Technol* 1991;35(3):231–7.
- Kurian JK, Raveendran GN, Hussain A, Raghavan GSV. Feedstocks, logistics and pre-treatment processes for sustainable lignocellulosic biorefineries: a comprehensive review. *Renew Sustain Energy Rev* 2013;25:205–19.
- Zafar S. Energy potential of bagasse. *Bioenergy Consult*. (<http://www.bioenergyconsult.com/energy-potential-bagasse/>); 2014 [last accessed, January 2015].
- Asadullah M. Barriers of commercial power generation using biomass gasification gas: a review. *Renew Sustain Energy Rev* 2014;29:201–15.
- Aul E. & Associates. Bagasse combustion in sugar mills. Emission factor documentation for AP-42, section 1.8.. (<http://134.67.104.12/html/chief/fbgdocs.htm>); 1993 [last accessed October 2014].
- Xu Q. Investigation of co-gasification characteristics of biomass and coal in fluidized bed gasifiers [Ph.D. thesis]. University of Canterbury; 2013.
- Anukam A, Mamphweli S, Meyer E, Okoh O. Gasification of sugarcane bagasse as an efficient conversion technology for the purpose of electricity generation. *Fort Hare Papers. Multidiscip J Univ Fort Hare* 2013;20(1) ISSN:0015-8054.
- Islam MR, Islam N and Islam MN. Fixed bed pyrolysis of sugarcane bagasse for liquid fuel production. In: *Proceedings of the international conference on mechanical engineering*. (paper ID ICME03)-TH-16, Dhaka, Bangladesh; 2003.
- Das P, Ganesh A, Wangikar P. Influence of pretreatment for deashing of sugarcane bagasse on pyrolysis products. *Biomass Bioenergy* 2004;27(5):445–57.
- Jorapur R, Rajvanshi AK. Sugarcane leaf-bagasse gasifiers for industrial heating applications. *Biomass Bioenergy* 1997;13(3):141–6.
- Tumuluru JS, Wright CT, Kenny KL, Hess JR. A review on biomass densification technologies for energy application. A technical report prepared for the U.S Department of Energy; 2010. Contract DE-AC07-05ID14517.
- Kumar A, Jones DD, Hanna MA. Thermochemical biomass gasification: a review of the current status of the technology. *Energies* 2009;2(3):556–81.
- Nordin A. Chemical elemental characteristics of biomass fuels. *Biomass Bioenergy* 1994;6:339–47.
- European Biomass Industry Association. Operational problems in biomass combustion. (<http://www.eubia.org/index.php/about-biomass/combustion/operational-problems-in-biomass-combustion>); 2012 [last accessed, December 2014].
- Capareda SC. Biomass energy conversion, Sustainable Growth and Applications in Renewable Energy Sources. In: Dr. Majid Nayeripour editors. ISBN: 978-953-307-408-5. InTech. (<http://www.intechopen.com/books/sustainable-growth-and-applications-in-renewable-energy-sources/biomasse-energy-conversion>); 2011 [last accessed January 2015].
- Gupta SC, Manhas P. Percentage generation and estimated energy content of municipal solid waste at commercial area of Janipur, Jammu. *Environ Conserv J* 2008;9(1):27–31.
- Annamalai K, Sweeten JM, Ramalingam SC. Estimation of Gross heating Values of Biomass Fuels. *Transactions of the ASAE. Am Soc Agric Eng* 1987;30(4):1205–8.
- Chandrakant T. Biomass Gasification-Technology and Utilisation. Humanity Development Library. Artes Institute, Glucksburg, Germany. ([www.pssurvi.com](http://www.pssurvi.com)); 2002 [Last accessed November 2012].
- Maciejewska A, Veringa H, Sanders J, Petevs S. Co-firing of biomass with coal: Constraints and role of biomass pre-treatment. Luxembourg: Office for Official Publications of the European Communities; 2006. p. 113.
- O'Donovan A, et al. Acid pre-treatment technologies and SEM Analysis of treated grass biomass in biofuel processing. *Biofuel Technologies*. Berlin Heidelberg: Springer; 2013. p. 97–118.
- Unger PW. Managing agricultural residues. Florida: CRC Press, Inc.; 1994.
- Nunes LJR, Matias JCO, Catalão JPS. A review on torrefied biomass pellets as a sustainable alternative to coal in power generation. *Renew Sustain Energy Rev* 2014;40:153–60.
- Sokhansanj S. Cost benefit of biomass supply and pre-processing, BIOCAP research integration program synthesis paper. Ottawa, Canada: BIOCAP Canada Foundation; 2006.
- Woodcock CR, Mason JS. Bulk solids handling: An introduction to the practice and technology. Glasgow, Scotland: Blackie and Son Ltd.; 1987.
- S Clarke and F. Preto Biomass densification for energy production. Factsheet of the Ontario Ministry of Agriculture, Food and Rural Affairs; 2011.
- Peleg M. Physical characteristics of food powders. In: Peleg M, Bagley EB, editors. *Physical properties of food*. Westport, Connecticut: AVI Publishing Company, Inc.; 1983. p. 293–321.
- Lam PS, Sokhansanj S, Bi X, Mani S, Lim CJ, Womac AR, Hoque M, Peng J, JayaShankar T, Naimi LJ, Nayaran S. Physical characterization of wet and dry wheat straw and switchgrass-bulk and specific density. In: Presented at the American Society of Agricultural and Biological Engineers International meeting, Minneapolis, Minnesota: Minneapolis Convention Center; 2007. [Paper no. 076058].
- Mani S, Tabil LG, Sokhansanj S. Grinding performance and physical properties of wheat and barley straws, corn stover and switchgrass. *Biomass Bioenergy* 2004;27(4):339–52.
- Mamphweli S. Implementation of a 150 KVA biomass gasifier system for community economic empowerment in South Africa [Ph.D. thesis]. University of Fort Hare, South East Academic Libraries System (SEALS); 2010 with website: <http://contentpro.seals.ac.za/iii/cpro/app?id=0191823284620280&itemld.def>.
- Mohan D, Pittman CU, Steele PH. Pyrolysis of wood/biomass for bio-oil: A critical review. *Energy Fuels* 2006;20:848–89.
- van Dam JEG, van den Oever MJA, Teunissen W, Keijsers ERP, Peralta AG. Process for production of high density/high performance binderless boards from whole coconut husk—Part 1: Lignin as intrinsic thermosetting binder resin. *Ind. Crops Prod*. 2004;19(3):207–16.
- Anglès MN, Ferrando F, Farriol X, alvadó J. Suitability of steam exploded residual softwood for the production of binderless panels: Effect of the pre-treatment severity and lignin addition. *Biomass Bioenergy* 2001;21:211–24.
- Granada E, González LML, Míguez JL, Moran J. Fuel lignocellulosic briquettes, die design, and products study. *Renew Energy* 2002;27:561–73.
- Murphy JD, McCarthy K. Ethanol production from energy crops and wastes

- for use as a transport fuel in Ireland. *Appl Energy* 2005;82:148–66.
- [51] Shaw M. Feedstock and process variables influencing biomass densification [Ph.D. thesis]. Saskatoon, Saskatchewan, Canada: University of Saskatchewan; 2008.
- [52] Lv D, Xu M, Liu X, Zhan Z, Li Z, Yao H. Effect of cellulose, lignin, alkali and alkaline earth metallic species on biomass pyrolysis and gasification. *Fuel Process Technol* 2010;91:903–9.
- [53] Kaupp A, Goss JR. Technical and economical problems in the gasification of rice hulls. Physical and chemical properties. *Energy Agric* 1981;1(201):1981–3.
- [54] Akay G, Jordan CA. Gasification of fuel cane bagasse in a downdraft gasifier: influence of lignocellulosic composition and fuel particle size on syngas composition and yield. *Energy Fuels* 2011;25:2274–83.
- [55] Di Blasi C, Signorelli G, Portorico G. Countercurrent fixed-bed gasification of biomass at laboratory scale. *Ind Eng Chem Res* 1999;38:2571–81.
- [56] Tallaksen J. Biomass gasification: A comprehensive demonstration of a community-scale biomass energy system. A case study in biomass pre-processing. Final report submitted to the USDA Rural Development Grant 68-3A75-5-232; 2011.
- [57] Tchapa HA, Pisupati SV. A review of thermal co-conversion of coal and biomass/waste. *Energies* 2014;2014(7):1098–148. <http://dx.doi.org/10.3390/en7031098> ISSN 1996-1073.
- [58] Kaliyan N, Morey RV, White MD, Doering A. Roller press briquetting and pelleting of corn stover and switchgrass. *Am Soc Agric Biol Eng* 2009;52(2):543–55.
- [59] Grover PD, Mishra SK. Biomass briquetting: Technology and practices. Regional Wood Energy Development Programme in Asia. Bangkok: Food and Agricultural Organization of the United Nations; 1996.
- [60] Visviva Renewable Energy. Various briquetting and pelletizing technologies. ([http://www.vvenergy.com/various\\_briquetting\\_and\\_pelletizing\\_technologies.html](http://www.vvenergy.com/various_briquetting_and_pelletizing_technologies.html)); 2011 [last accessed, December 2014].
- [61] FAO Corporate document repository. The briquetting of agricultural wastes for fuel. (<http://www.fao.org/docrep/t0275e/t0275e05.htm#Chapter%208>. Hydraulic%20piston%20presses); 2013 [last accessed, December 2014].
- [62] Agro Energy. Bagasse biomass briquettes. (<http://www.indiamart.com/rk-agro/bagasse-briquettes.html>); 2014 [last accessed December 2014].
- [63] Nielsen CF. Basic Briquetting Control System-A real briquette maker. (<http://www.cfnelsen.com/producten/22>); 2014 [last accessed December 2014].
- [64] Yehia KA. Estimation of roll press design parameters based on the assessment of a particular nip region. *Powder Technol* 2007;177:148–53.
- [65] Chandak SP. Physical conversion technologies. A training on technologies for converting waste agricultural biomass into energy. San Jose, Costa Rica: Organized by United Nations Environment Programme (UNEP, DTIE, IETC); 2013.
- [66] MacMahon MJ. Additives for physical quality of animal feed. In: Beaven DA, editor. *Manufacturing of Animal Feed*. Herts, England: Turret-Wheatland Ltd.; 1984. p. 69–70.
- [67] Yaman S, Şahan M, Haykiri-çama H, Şeşen K, Küçükbayrak S. Production of fuel briquettes from olive refuse and paper mill waste. *Fuel Process Technol* 2000;2000(68):23–31.
- [68] Li Y, Liu H. High pressure densification of wood residues to form an upgraded fuel. *Biomass Bioenergy* 2000;19:177–86.
- [69] Demirbas A, Şahin-Demirbaş A, Demirbaş AH. Briquetting properties of biomass waste materials. *Energy Sources* 2004;26:83–91.
- [70] Hill B and Pulkinen DA. A study of factors affecting pellet durability and pelleting efficiency in the production of dehydrated alfalfa pellets 1998; A special Report. Vol. 25. Tisdale, SK, Canada: Saskatchewan Dehydrators Association; 1988.
- [71] Smith IE, Probert SD, Stokes RE, Hansford RJ. The briquetting of wheat straw. *J Agric Eng Res* 1977;22:105–11.
- [72] Butler JL, McColly HF. Factors affecting the pelleting of hay. *Agric Eng* 1959;40:442–6.
- [73] Tabil LG, Sokhansanj S. Process conditions affecting the physical quality of alfalfa pellets. *Am Soc Agric Eng* 1996;12(3):345–50.
- [74] Shankar TJ, Sokhansanj S, Bandyopadhyay S, Bawa AS. A case study on optimization of biomass flow during single screw extrusion cooking using genetic algorithm (GA) and response surface method (RSM). *Food Bioprocess Technol*. 2008;3(4):498–510.
- [75] Kaliyan N, Morey R. Densification characteristics of corn stover and Switchgrass. In: Presented at the ASABE annual international meeting. Portland, OR, ASABE Paper No. 066174, ASAE, St. Joseph, MI, USA; 2006.
- [76] Heffner LE, Pfost HB. Gelatinization during pelleting. *Feedstuff* 1973;45(23):33.
- [77] Shankar TJ, Bandyopadhyay S. Process variables during single screw extrusion of fish and rice flour blends. *J Food Process Preserv* 2005;29:151–64.
- [78] Al-Widyan MI, Al-Jalil HF, Abu-Zreig MM, Abu-Handeh NH. Physical durability and stability of olive cake briquettes. *Can Biosyst Eng* 2002;44:341–5.
- [79] Van der Stelt MJC, Gerhauser H, Kiel JHA, Ptasinski KJ. Biomass upgrading by torrefaction for the production of biofuels: a review. *Biomass Bioenergy* 2011;35:3748–62.
- [80] Felfli FF, Luengo CA and Beaton PA. Bench unit for biomass residues torrefaction. In: Kopetz H. editor. *Biomass for Energy and Industry*. Proceedings in international conference. Wurzburg, Germany; 1998. p. 1593–95.
- [81] Lehtikangas P. Quality properties of fuel pellets from forest biomass [Licentiate Thesis]. Department of Forest Management and Products, Report 4, Uppsala; 1999.
- [82] Bergman PCA, Kiel JHA. Torrefaction for Biomass Upgrading. In: Published at the 14th European biomass conference and exhibition. Paris, France; 2005.
- [83] Bergman PCA. Combined torrefaction and pelletisation: The TOP process 2005; ECN-C-05-073.
- [84] Arcate JR. Global markets and technologies for torrefied wood in 2002. *Wood Energy* 2002;5:26–8.
- [85] Zanzi R, Ferro DT, Torres A, Soler PB and Bjornbom E. Biomass torrefaction. In: Proceedings of the 6th Asia-Pacific international symposium on combustion and energy utilization. Kuala Lumpur; 2002.
- [86] Shafizadeh F. Pyrolytic reactions and products of biomass. In: Overend RP, Milne TA, Mudge LK, editors. *Fundamentals of Biomass Thermochemical Conversion*. London: Elsevier; 1985. p. 183–217.
- [87] Williams PT, Besler S. The influence of temperature and heating rate on the slow pyrolysis of biomass. *Renew Energy* 1996;7:233–50.
- [88] Bourgeois J, Doat J. Proceedings of Conference on Bioenergy. Vol. 3. Göteborg; 1985, p. 153.
- [89] Bergman PCA, Boersma AR, Kiel JHA, Zwart RWH. Development of torrefaction for biomass co-firing in existing coal-fired power stations. *Biocoal Concept Version*, ECN Report; 2005.
- [90] Hakkou M, Pétrissans M, Gérardin P, Zoulalian A. Investigation of the reasons for fungal durability of heat-treated beech wood. *Polym Degrad Stab* 2006;91:393–7.
- [91] Arias B, Pedida C, Feroso J, Plaza MG, Rubiera F, Pis JJ. Influence of torrefaction on the grindability and reactivity of woody biomass. *Fuel Process Technol* 2008;89:169–75.
- [92] Pastorova I, Arisz PW, Boon JJ. Preservation of D-glucose oligosaccharides in cellulose chars. *Carbohydr Res* 1993;248:151–65.
- [93] Wooten JB, Crosby B, Hajaligol MR. Evaluation of cellulose char structure by 13C CP/MAS NMR. *Fuel Chem Div* 2000;46:191–3.
- [94] Uslu A, André PC, Faaij AB, Bergman PCA. Pre-treatment technologies, and their effect on international bioenergy supply chain logistics. Techno-economic evaluation of torrefaction, fast pyrolysis, and pelletization. *Energy* 2008;33:1206–23.
- [95] Prins MJ. Thermodynamic analysis of biomass gasification and torrefaction [Ph.D. thesis]. The Netherlands: Eindhoven Technical University; 2005.
- [96] Sadaka S, Negi S. Improvements of biomass physical and thermochemical characteristics via torrefaction process. *Environ Prog Sustain Energy* 2009;28(3):427–34.
- [97] Bridgeman TG, Jones JM, Shiel I, Williams PT. Torrefaction of reed canary grass, wheat straw and willow to enhance solid fuel qualities and combustion properties. *Fuel* 2008;87:844–56.
- [98] Bhattacharya SC, Sett S, Shrestha RM. State-of-the-Art for biomass densification. *Energy Sources* 1989;11:161–82.
- [99] Bhattacharya SC. State-of-the-Art of utilizing residues and other types of biomass as an energy source. *RERIC Int Energy J* 1993;15(1):1–21.
- [100] Aqa S, Bhattacharya SC. Densification of preheated sawdust for energy conservation. *Energy* 1992;17(6):575–8.
- [101] FAO. Biomass briquetting: Technology and Practices. In regional wood energy development program in Asia 1996; Report prepared by P.D. Grover and S. K. Mishra, GCP/RAS/154/NET,f40\_97.html; October 29, 2007.
- [102] Apted D. Dryers. Alaska Pellet Mill. Anchorage Alaska. (<http://www.alaska-pelletmill.com/dryers>); 2014 [last accessed January 2015. Last accessed March 2015].
- [103] Lv P, Yuan Z, Ma L, Wu C, Chen Y, Zhu J. Hydrogen-rich gas production from biomass air and oxygen/steam gasification in a downdraft gasifier. *Renew Energy* 2007;32:2173–85.
- [104] Yan F, Luo S-Y, Hu Z-Q, Xiao B, Cheng G. Hydrogen-rich gas production by steam gasification of char from biomass fast pyrolysis in a fixed-bed reactor: influence of temperature and steam on hydrogen yield and syngas composition. *Bioresour Technol* 2010;101:5633–7.
- [105] Hosseini M, Dincer I, Rosen MA. Steam and air fed biomass gasification: comparisons based on energy and exergy. *Int J Hydrog Energy* 2012;37:16446–52.
- [106] Singh RN. Equilibrium moisture content of biomass briquettes. *Biomass Bioenergy* 2004;26:251–3.
- [107] Bitra VSP, Womac AR, Chevanan N, Miu PI, Igathinathane C, Sokhansanj S, et al. Direct mechanical energy measured of hammer mill comminution of switchgrass, wheat straw, and corn stover and analysis of their particle size distributions. *Powder Technol* 2009;193:32–45.
- [108] Soucek J, Hanzlikova I, Hulta P. A fine disintegration of plants suitable for composite biofuels production. *Res Agric Eng* 2003;49(1):7–11.
- [109] Lopo P. The right grinding solution for you: roll, horizontal or vertical. *Feed Manag* 2002;53(3):203–6.
- [110] Tumuluru JS, Tabil LG, Song Y, Iroba KL, Meda V. Grinding energy and physical properties of chopped and hammer-milled barley, wheat, oat, and canola straws. *Biomass Bioenergy* 2014;60:58–67.
- [111] Peleg M, Mannheim CH. Effect of conditioners on the flow properties of powdered sucrose. *Powder Technol* 1973;7:45–50.
- [112] Drzymala Z. Industrial briquetting-fundamentals and methods. Studies in mechanical engineering. 13 Warszawa: PWN-Polish Scientific Publishers; 1993.
- [113] Agar D, Wihersaari M. Torrefaction technology for solid fuel production. *GCB Bioenergy* 2012;4(5):475–8.
- [114] Gustafsson E. Characterization of particulate matter from atmospheric fluidized bed biomass gasifiers [Ph.D. thesis]. Linnaeus University; 2011 <https://www.divaportal.org/smash/get/diva2:412937/FULLTEXT01.pdf>.

- [115] Jayah TH. Evaluation of a downdraft wood gasifier for tea manufacturing in Sri Lanka. Master's dissertation. The University of Melbourne; 2002.
- [116] Reed TB. Types of gasifiers and gasifier design considerations. In: Reed TB editor. Biomass gasification, Principles and Technology. New Jersey: Noyes Data Corp.; 1981. p. 184–99.
- [117] Buekens AG, Schoeters JG. In: Overend RP, Milne TA, Mudge LK, editors. Modelling of biomass gasification. Fundamentals of Thermochemical Biomass. London: Elsevier; 1985.
- [118] Graboski M, Bain R. Properties of biomass relevant to gasification. In: Reed TB editor. Biomass Gasification, Principles and Technology. New Jersey: Noyes Data Corp; 1981. p. 41–69.
- [119] Reed TB, Das A. Handbook of biomass downdraft gasifier engine system. Golden, Colorado: SERI; 1988.
- [120] Reed TB, Markson M. A predictive model for stratified downdraft gasification of biomass. In: Tillman DA, Jahn EC, editors. Progress in biomass conversion, 4. New York: Academic Press; 1983. p. 219–54.
- [121] Solar Energy Research Institute (SERI). Generator Gas-The Swedish Experience from 1939–1945. Golden, Colorado: SERI.; 1979 [Chapter 2].
- [122] National Energy Technology Laboratory. Gasification Technology R&D. World Gasification Database. (<http://energy.gov/fe/science-innovation/clean-coal-research/gasification/>); 2010 [last accessed, December 2014].
- [123] Sami M, Annamalai K, Wooldridge M. Co-firing of coal and biomass fuel blends. Prog Energy Combust Sci 2001;27:171–214.
- [124] Surridge AD. Carbon sequestration leadership forum: South Africa status report. Report to the National Committee on Climate Change. Pretoria; 2004.
- [125] Hitchon B. Aquifer disposal of carbon dioxide: Hydrodynamic and mineral trapping-proof of concept. Alberta, Canada: Geoscience Publishing; 1996.
- [126] National Energy Technology Laboratory. An overview. NETL gasification technologies Training; 2004. [Reprinted from M. Ramezan, Coal-based gasification technologies course].
- [127] Food and Agriculture Organization of the United Nations. Wood gas as engine fuel 1986; ([www.fao.org](http://www.fao.org/)); 1986 [last accessed, April 2012].
- [128] Rajvanshi AK. Biomass gasification. In: Yogi Goswami D, editor. Alternative energy in agriculture, vol. 2. CRC Press; 1986. p. 83–102 [Chapter 4].
- [129] Westinghouse Plasma Corporation. Waste to Energy. ([http://www.westinghouse-plasma.com/waste\\_to\\_energy/](http://www.westinghouse-plasma.com/waste_to_energy/)); 2015 [last accessed January 2015].
- [130] Eggen A, Kraatz R. Gasification of solid waste in fixed beds. Mech Eng 1976;98:24–9.
- [131] Panwar NL, Kothari R, Tyagi VV. Thermo chemical conversion of biomass-Eco friendly energy routes. Renew Sustain Energy Rev 2012;16:1801–16.
- [132] Lalou C. Distributed power with advanced clean coal gasification technology. Cornerstone. The official Journal of The World Coal Industry. (<http://cornerstonemag.net/distributed-power-with-advanced-clean-coal-gasification-technology/>); 2014 [last accessed, January 2015].
- [133] Van der Drift A, Boerigter H, Coda B, Cieplik M, Hemmes K. Entrained flow gasification of biomass. Ash behaviour, feeding issues, and system analyses. ECN Energy Innov 2004 ECN-C-04-039.
- [134] National Energy Technology Laboratory. (<http://www.netl.doe.gov/>); 2012 [last accessed, May 2012].
- [135] National Energy Technology Laboratory. Commercial gasifier: entrained flow gasifiers. (<http://www.netl.doe.gov/research/coal/energysystems/gasification/gasifipedia/entrainedflow/>); 2006 [last accessed, December 2014].
- [136] Lewis R. The recovered energy system. Extracting energy from waste without combustion. A discussion on plasma gasification. ([http://www.recoverenergy.com/d\\_plasma.html](http://www.recoverenergy.com/d_plasma.html)); 2014 [last accessed, December 2014].
- [137] Phoenix Energy. Plasma gasification. (<http://www.phoenixenergy.com.au/plasma-gasification/>); [last accessed, December 2014].
- [138] Schapfer P, Tobler J. Theoretical and practical investigations upon the driving of motor vehicles with wood gas. Bern; 1937.
- [139] Mamphweli NS, Meyer LE. Evaluation of the conversion efficiency of a 180 Nm<sup>3</sup>/h Johansson biomass gasifier. Int J Energy Environ 2010;1(1):113–20.
- [140] Milne T, Evans R, Abatzoglou N. Biomass gasifiers "Tars": Their nature, formation, and conversion. National Renewable Energy Laboratory. (<http://www.nrel.gov/docs/fy99osti/25357.pdf>); 1998 [last accessed December 2015].
- [141] Hanaoka T, Minowa T, Miyamoto A, Edashige Y. Effect of chemical property of waste biomass on air-steam gasification. J Jpn Inst Energy 2005;84:1012–8.
- [142] Corella J, Aznar MP, Delgado J, Aldea E. Steam gasification of cellulosic wastes in a fluidized bed with downstream vessels. Ind Eng Chem Res 1991;30:2252–62.
- [143] Higman C, van der Burgt M. Gasification. United States of America: Gulf Professional Publishing; 2003.
- [144] Antal Jr. JM, Edwards WE, Friedman HL, Rogers RE. A study of the steam gasification of organic wastes. Project report to United States Environmental Protection Agency: Liberick, W.W. Project Officer; 1984.
- [145] Abatzoglou N, Barker N, Hasler P, Knoef H. The development of a draft protocol for the sampling and analysis of particulate and organic contaminants in the gas from small biomass gasifiers. Biomass Bioenergy 2000;18:5–17.
- [146] Maniatis K, Beenackers AACM. Introduction: tar protocols. IEA Bioenergy gasification task. Biomass Bioenergy 2000;18:1–4.
- [147] Franco C, Pinto F, Gulyurtlu I, Cabrita I. The study of reactions influencing the biomass steam gasification process. Fuel 2003;82:835–42.
- [148] Turn S, Kinoshita C, Zhang Z, Ishimura D, Zhou J. An experimental investigation of hydrogen production from biomass gasification. Int J Hydrog Energy 1988;23:641–8.
- [149] Walawender WP, Hoveland DA, Fan LT. Steam gasification of pure cellulose. 1. Uniform temperature profile. Ind Eng Chem Process Des Dev 1985;24:813–7.
- [150] Florin NH, Harris AT. Enhanced hydrogen production from biomass with in situ carbon dioxide capture using calcium oxide sorbents. A review. Chem Eng Sci 2008;63:287–316.
- [151] Dayton D. A review of the literature on catalytic biomass tar destruction; 2002. [NREL/TP-510-32815].
- [152] Han J, Kim H. The reduction and control technology of tar during biomass gasification/pyrolysis: an overview. Renew Sustain Energy Rev 2006. <http://dx.doi.org/10.1016/j.rser.2006.07.015>.
- [153] Sutton D, Kelleher B, Ross JRH. Review of literature on catalysts for biomass gasification. Fuel Process Technol 2001;72:155–73.
- [154] Sutton D, Kelleher B, Doyle A, Ross JRH. Investigation of nickel supported catalysts for the upgrading of brown peat derived gasification products. Biosource Technol 2001;80:111–6.
- [155] The Global Carbon Capture and Storage Institute. Gasification by-products. (<http://decarboni.se/publications/34-gasification-products>); 2014 [last accessed February 2015].
- [156] Koppejan J, Sokhansanj S, Melin S, Madrali S. Status overview of torrefaction technologies. IEA Bioenergy Task 32 report. ([http://www.ieabcc.nl/publications/IEA\\_Bioenergy\\_T32\\_Torrefaction\\_review.pdf](http://www.ieabcc.nl/publications/IEA_Bioenergy_T32_Torrefaction_review.pdf)); 2012. p.1–54 [last accessed December 2015].