

Available online at www.sciencedirect.com

ScienceDirect

Physics Procedia 67 (2015) 116 – 122

Physics

Procedia

25th International Cryogenic Engineering Conference and the International Cryogenic Materials Conference in 2014, ICEC 25–ICMC 2014

Simulation of a novel single-column cryogenic air separation process using LNG cold energy

Zheng Jieyu^a, Li Yanzhong^{a, b, *}, Li Guangpeng^a, Si Biao^a

^a Institute of Refrigeration and Cryogenics, Xi'an Jiaotong University, Xi'an 710049, China

^b State Key Laboratory of Multiphase Flow in Power Engineering, Xi'an 710049, China

Abstract:

In this paper, a novel single-column air separation process is proposed with the implementation of heat pump technique and introduction of LNG cold energy. The proposed process is verified and optimized through simulation on the Aspen Hysys® platform. Simulation results reveal that the power consumption per unit mass of liquid product is around 0.218 kWh/kg, and the total exergy efficiency of the system is 0.575. According to the latest literatures, an energy saving of 39.1% is achieved compared with those using conventional double-column air separation units. The introduction of LNG cold energy is an effective way to increase the system efficiency.

© 2015 The Authors. Published by Elsevier B.V. This is an open access article under the CC BY-NC-ND license (<http://creativecommons.org/licenses/by-nc-nd/4.0/>).

Peer-review under responsibility of the organizing committee of ICEC 25-ICMC 2014

Keyword: heat pump; cryogenic air separation; single-column process; LNG cold energy recovery; Aspen Hysys® simulation

Nomenclature

Ex	enthalpy exergy of working fluid (J/s)
Ex_{in}	net input exergy of the system (J/s)
Ex_{out}	net output exergy of the system (J/s)
H	enthalpy of the working fluid at the end state (J/s)
H_0	enthalpy of the working fluid at reference environmental state (J/s)
m_{LN}	mass flow rate of liquid nitrogen (kg/h)

* Corresponding author. Tel: +86-29-82668725; Fax: +086-29-82668789
E-mail address: yzli-epe@mail.xjtu.edu.cn

m_{LOX}	mass flow rate of liquid oxygen (kg/h)
N_{LIQ}	power consumption per unit mass of liquid product (kW·h/kg)
N_{LOX}	power consumption per unit mass of liquid oxygen (kW·h/kg)
N_{TOTAL}	total power consumption of the entire system (kW·h/kg)
S	entropy of the working fluid at the end state (J/K·s)
S_0	entropy of the working fluid at reference environmental state (J/K·s)
T_0	temperature at the reference environmental state (K)

Abbreviations

APS	air pretreatment system
ASP	air separation process
DS	distillation system
LC	lower column
LMTD	logarithmic mean temperature difference
LNG	liquefied natural gas
LTRS	LNG thermal recovery system
PPU	pre-purification unit
UC	upper column

Greek symbols

η_{ex}	system exergy efficiency
-------------	--------------------------

1. Introduction

Liquefied natural gas (LNG) as a clean and high efficient source of energy is transported all around the world. With a storage temperature of 110 K, LNG's utilization requires revaporization before transmission to the costumers, which is generally a heat transferring process with seawater or ambient air in the practice, 230 kWh/t of valuable cold energy gets wasted. LNG cold energy is used in freezing foods, making dry ice, low temperature crushing, light ends fractionation, air separation, etc. Over all, the air separation process (ASP), with a minimum temperature of 100 K (feed air) available through heat exchanging, is most suitable for full recovery of LNG cold energy.

The concept of ASP using external cold resources has long been proposed. Baxter [1] published a conceptual ASP with an auxiliary refrigerating cycle at an early stage. It's not until the 1980s that the technology of air separation integrated with the LNG cold energy has grown to maturity, and was applied to several engineering practices in Japan, Korea, France and China. Takagi and Nagamura [2] brought forward a more economical method to use external cold source effectively in an air separation apparatus. Agrawal [3] from company APCI presented his invention involving several LNG integrated processes for liquefaction of the nitrogen stream produced by a cryogenic air separation unit. Chinese researchers started the research on LNG integrated air separation technology since Chen et al. [4] first proposed a process with the combination of inner and out nitrogen cycle. Simulation results showed that system producing 1 kg liquefied oxygen can save 60 to 73.5% of the consumed electric energy compared with those without LNG. Recently, Xu et al. [5] proposed a comparatively more mature and simple ASP based on the processes of Chen et al. [4], and Yan et al. [6], which widens the operating temperature range of LNG cold energy from 133 -203 K to 113 -283 K.

Generally speaking, the LNG integrated air separation system can be divided into three parts: the air pretreatment system (APS), distillation system (DS) and LNG thermal recovery system (LTRS). Among all the accessible studies, the main focus is on the improvement of LTRS, while none of them focuses on the distillation system. The conventional double-column cryogenic ASP is the most popular choice. However, the occurrence of high-pressure column makes it necessary to compress all the feed air, while essentially only the nitrogen in the air needs compression. In this sense, an approximate energy saving of 20% (the volume content of oxygen in atmosphere) can be achieved by eliminating the pressure difference between columns. Such an innovative cryogenic ASP was recently proposed by Kansha et al. [7] based on self-heat recuperation technology with the column operating pressure of 200 kPa gauge, and Zhou et al. [8] proposed a cryogenic ASP operating at 0.13 MPa. Fu and Gundersen

[9] disclosed a scheme of recuperative vapor recompression heat pumps to substitute the conventional thermally coupled distillation columns. Based on previous researches, a novel one-column ASP using LNG cold energy is proposed and simulated in this work. The basic idea is to combine the newly developed cryogenic ASP with an LTRS to improve the power efficiency in large-scale LNG receiving terminal station.

2. Process discussion

Heat pump technology is one of the most commonly used ways to maximize the thermodynamic efficiency of the sub-ambient distillation process. Such an application has been discussed by Fu and Gundersen [9]. Unlike the case in above-ambient distillation, heat is always more valuable than work in sub-ambient temperatures. Consequently, compression is preferably done at around ambient temperature. Another advantage of this configuration is the avoidance of low temperature compression which may cause technical barriers. Fig. 1(a), demonstrates a fairly detailed flowsheet of an atmospheric one-column ASP. The key feature of this process is the substitution of a nitrogen compressor for the traditional air compressor. Such a modification dramatically decreases the operation pressure of the distillation column. Moreover, the traditional two columns can also be substituted by a single column, since the two columns are operated at the same pressure, which results in a reduction of equipment investment. In order to make up the cold energy deficit as well as to maintain a reasonable temperature differences in the multi-stream heat exchangers, an additional refrigeration cycle is used. The combination of compressor and expander in the refrigeration cycle can be substituted by a compander to achieve more energy savings.

Inert gas recycle such as nitrogen or argon is commonly used to act as a medium to transfer refrigeration from the LNG to the air separation plant for the sake of safety. The recycled gas is better not introduced into the distillation column system as with the prior art, in consideration of mitigating of the potential risk of the formation of very hazardous mixtures with oxygen. On the basis of such knowledge, the novel process is proposed and demonstrated in Fig. 1(b). A part of pure nitrogen is recompressed by main compressor (M-Com) to 0.45 MPa, then condensed against liquid nitrogen (0.38 MPa), liquefied at the LNG heat-exchanger system and oxygen from the bottom of the column. The obtained liquid is then further cooled and throttled to 0.12 MPa as the reflux of the distillation column. Another part of the pure nitrogen is compressed to around 1.8 MPa acting as a medium transferring LNG cold energy and is self-liquefied. The obtained liquid nitrogen is partly pumped to 8 to 10 MPa as working fluid for a refrigeration cycle making up the cold energy deficit of the LNG heat-exchanger system. Another part of it is extracted to maintain the operation of the distillation system. The rest is restored as the product. The liquid oxygen product is obtained from the bottom of the distillation column.

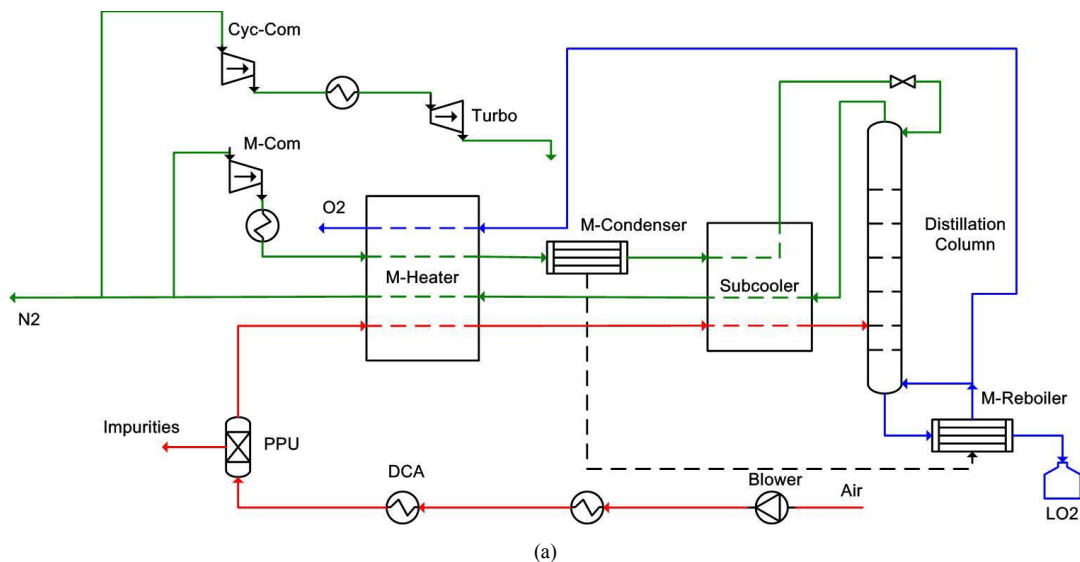

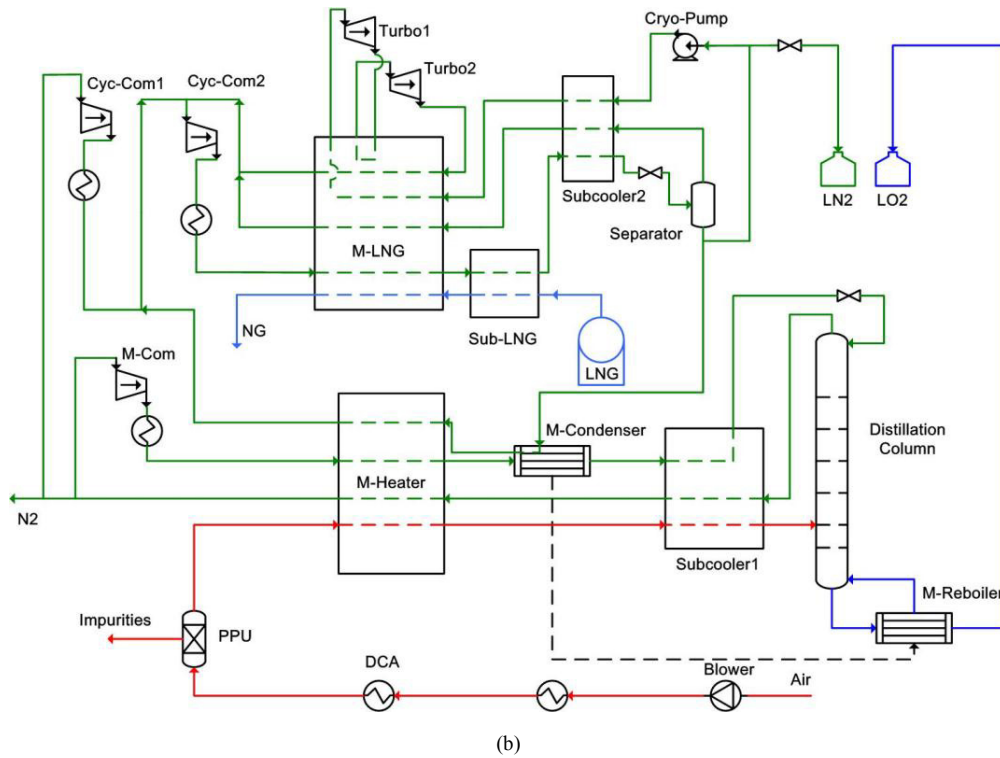

Fig. 1. Flowsheet of single-column atmospheric cryogenic ASP.

3. Case study

3.1. Operational conditions and analysis methods

All the presented cycles are simulated with Aspen HYSYS[®]. The Peng-Robinson (PR) method is employed for calculating the thermodynamic properties of air separation related streams and SRK property method for LNG. The feed air (298.15 K, 0.1 MPa) flow rate is 50,000 Nm³/h. The desired products are high-purity liquid nitrogen (99.999 mol %) and liquid oxygen (around 99.8 mol %).

The isentropic and mechanical efficiency of the feed air compressor and nitrogen compressor is 0.8 and 0.95, respectively. The isentropic and mechanical efficiency of turbine and cryogenic pump is 0.75 and 0.95, respectively. The minimum temperature approach of the Sub-LNG heat-exchanger is 1 K, while that of the other heat-exchangers is 1.5 K for practical consideration. All logarithmic mean temperature difference (LMTD) for the heat-exchanger is confined to as low as possible. The cold energy loss rate is 20 kW for the system.

Previous researchers mainly refer to the power consumption per unit mass of liquid products and oxygen (referred to as formula (1) and (2)) to evaluate the overall power consumption performance of the LNG cold energy integrated ASP. However, the valuable LNG cold energy, which is converted directly from mechanical work, is neglected in the overall power efficiency evaluation of the plant. Through introduction of exergy analysis in the next section, we are capable of treating the LNG cold energy equally as power consumption.

$$N_{LIQ} = \frac{N_{TOTAL}}{m_{LN} + m_{LOX}}, \tag{1}$$

$$N_{LOX} = \frac{N_{TOTAL}}{m_{LOX}}, \tag{2}$$

where N_{LIQ} is the power consumption per unit mass of liquid product, N_{TOTAL} is the total power consumption of a specified system, and m_{LN} and m_{LOX} are the mass flow rate of liquid nitrogen and oxygen product, respectively. N_{LOX} is the power consumption per unit mass of liquid oxygen, characterizes the oxygen producing efficiency of the process.

Exergy analysis is commonly used to analyze the irreversibility of all the parts and the whole system with the system gray box analysis model being used. The process is only a physical change process of steady flow, i.e. no chemical reaction is involved. Therefore only the physical exergy of each stream is calculated in this paper, and the exergy of streams is calculated by the formula (3). For simplicity, the environmental air contains 20.9% oxygen and 79.1% nitrogen, LNG merely contains methane. The reference environmental state is defined as 0.1MPa, 298.15K, were represented as subscript "0".

$$Ex = (H - H_0) - T_0(S - S_0). \quad (3)$$

The system exergy efficiency is calculated by the formula (4):

$$\eta_{ex} = \frac{Ex_{out}}{Ex_{in}}. \quad (4)$$

3.2. Result and discussion

The LNG cold energy integrated air separation system can be divided into three parts: the APS, DS and LTRS. The APS mainly deals with the impurities in the feed air. The power consumption of this system is approximately estimated according to the study of Jin and Hu [10]. The DS is the vital part of the entire system, due to limitations of space, this work will not be discussed in this paper, and some of the important operation parameters are listed in Table 1.

Table 1. Operation conditions for distillation column.

Number of stages	feedstock					Reflux Nm ³ /h	Reflux ratio	Liquid oxygen Nm ³ /h	Liquid nitrogen Nm ³ /h
	Type of feedstock	Position of feedstock	Flow rate Nm ³ /h	Quality of feed air	P/MPa				
60	air	30	50,000	0.99	0.12	31,950	1.58	10,250	14,287

In the following section, the variation characteristics of the LTRS will be investigated, the exergy efficiency η_{ex} of total system, exergy efficiency η_{ex} of LTRS, N_{LIQ} and N_{LOX} of the total system and N_{LIQ} of the LTRS will be calculated as the basis for plant performance comparison. To focus on the main characteristic of the system, the shaft work is used during the calculation of exergy efficiency.

3.2.1. Optimization of the LTRS

Fig. 2 indicates the performance of the total system and LTRS varied with cyclic nitrogen flow rate. N_{LIQ} and N_{LOX} decreases greatly as the cyclic nitrogen flow rate changing from 40 to 60 kNm³/h. Correspondingly, the total exergy efficiency increases in this process. However, the performance of the LTRS is less influenced by the cyclic nitrogen flow rate as the exergy efficiency η_{ex} and N_{LIQ} of the LTRS is slightly decreased and increased with the changing of the flow rate, respectively.

The maximum pressure of cyclic nitrogen is directly influencing performance of the heat exchangers in the LTRS. As showed in Fig. 3, N_{LIQ} and N_{LOX} increases as the maximum pressure of cyclic nitrogen varies from 40 to 60 kNm³/h. The total exergy efficiency decreases in this process. The exergy efficiency η_{ex} and N_{LIQ} of the LTRS is decreased and increased with the changing of the maximum pressure of cyclic nitrogen, respectively.

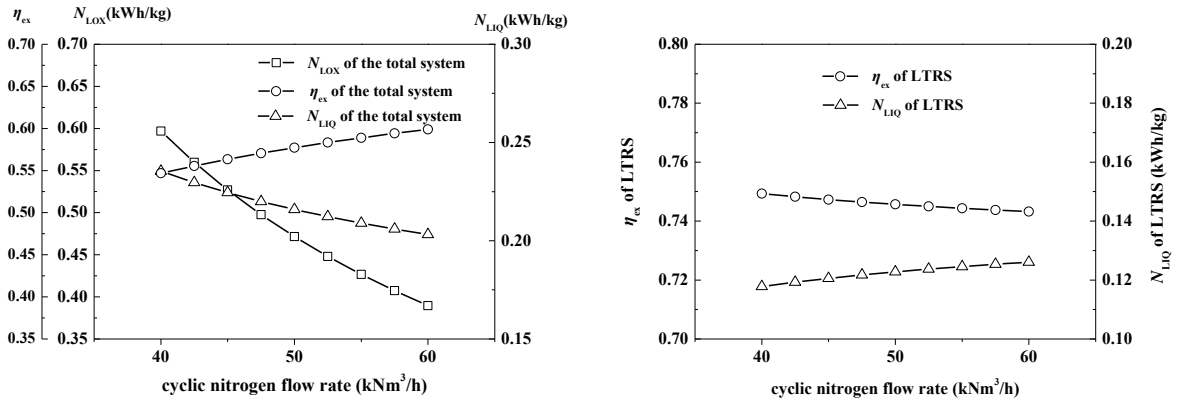

Fig. 2. The systematic performance varied with the cyclic nitrogen flow rate.

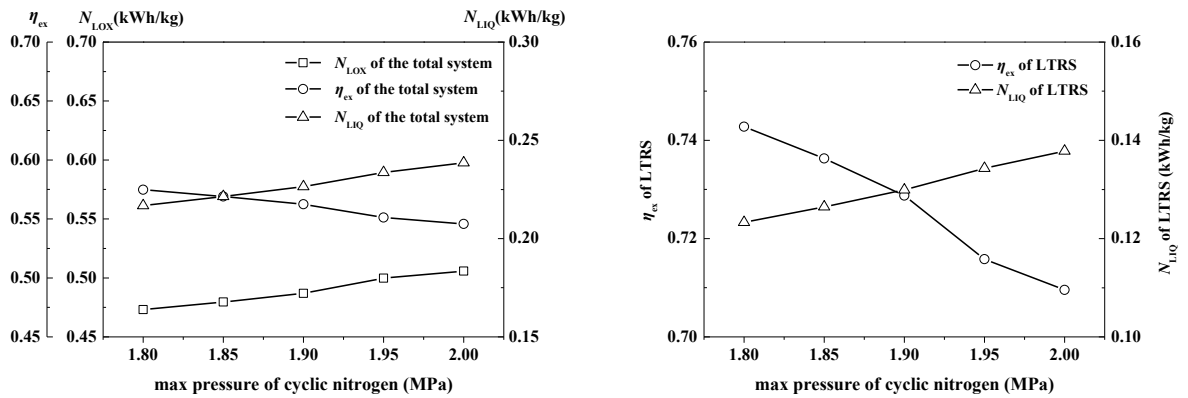

Fig. 3. The systematic performance varied with maximum pressure of cyclic nitrogen.

The total system will perform better at a higher cyclic nitrogen flow rate and a lower cyclic pressure at the same time. Yet, the cyclic nitrogen pressure must be over 1.72 MPa to maintain a necessary heat exchanging temperature difference from LNG to nitrogen. The practical minimum temperature difference is set at 1 K according to Fu and Gundersen [9], and thus the optimal value 1.82 MPa. As a compromise of quicker start-up of the process and the power efficiency, the cyclic nitrogen flow rate is set at 50,000 Nm³/h, and the pump pressure at 9 MPa.

3.2.2. Plant performance comparison

Based on the discussion in the section 3.2.1, the optimal parameters are obtained. Compared with the similar works by Xu et al. [5], as showed in Table 2, the proposed process is more efficient in producing liquid product with a N_{LIQ} around 0.218 kWh·kg⁻¹. However, the flow ratio of cyclic nitrogen and processing air is greater than the traditional process, which means a longer start-up time.

The total exergy efficiency is 50.5% higher than the traditional process. The LNG may be compressed before entering the LTRS, since LNG at elevated pressure have a better heat exchanging matching characteristic, and further studies can be done on the design of new LTRS with a higher LNG cyclic pressure.

Table 2. Simulation results of the traditional and novel LNG cold energy integrated ASPs.

Technical Specifications	Traditional process	Novel process
Handling capacity of air (t·h ⁻¹)	20	20
LNG outlet pressure (MPa), Temperature (K)	3.0, 300	0.11, 283
LNG consumption (t·h ⁻¹)	4.98	4.434
Flow ratio of cyclic nitrogen and processing air	0.6875	0.9713
Compression work of air (kW)	1580	113.6
Compression work of nitrogen (kW)	462.6	2029.5
Air pretreatment system power consumption (kW)	600	142.9
The maximum operating pressure (MPa)	2.6	1.82
Power consumption per unit mass of liquid products (kWh·kg ⁻¹)	0.358	0.218
Total exergy efficiency (%)	38.2	57.5

4. Conclusion

A novel single-column ASP using LNG cold energy is proposed. Compared with the conventional ASU application, the novel process utilizes a nitrogen compressor acting as a heat pump, which recuperates both the latent and sensible heat in the system. The process is verified and optimized on the Aspen HYSYS[®] simulation platform. Results show that the cyclic nitrogen flow rate and maximum pressure of cyclic nitrogen are the vital factors for a LNG heat exchanger system. The obtained optimal cyclic pressure is 1.82 MPa. As a compromise of quicker start-up of the process and the power efficiency, the cyclic nitrogen flow rate is set at 50,000 Nm³/h, and the pump pressure at 9 MPa. The proposed process provides standard liquid products of nitrogen (99.999%) and oxygen (99.8%) at 14,287 Nm³/h and 10,250 Nm³/h, respectively. The N_{LIQ} is 0.218 kWh/kg, and the total exergy efficiency of the system is 0.575, which is a 39.1% lower energy consumption and a 50.5% higher efficiency than those of the traditional process. LTRS with elevated LNG pressure would further improve the power efficiency.

Acknowledgement

This work was supported by the research fund of National Key Technology Support Program of China (2012BAA08B03), National Natural Science Foundation of China (51376142), and the Specialized Research Fund for the Doctoral Program of University by MOE China (20130201110069). The authors would like to thank the organizations above for their financial support.

References

- [1] Baxter GJ. Process and apparatus for the low temperature separation of air. *US3058314*; 1962.
- [2] Takagi HLLSD and Nagamura TLLSD. Method of using an external cold source in an air separation apparatus. *EP0304355 B1*; 1991.
- [3] Agrawal R. Liquefied natural gas refrigeration transfer to a cryogenics air separation unit using high pressure nitrogen stream. *US5137558*; 1992.
- [4] Chen Z, Cheng W and Hu P. A new air separation system by using cold energy of LNG. *J Eng Thermophys-Rus* 2004; 25: 913-6.
- [5] Xu W, Duan J and Mao W. Process study and exergy analysis of a novel air separation process cooled by LNG cold energy. *J Therm Sci* 2014; 23: 77-84.
- [6] Yan N, Li Y and Tuo H. Novel liquid product air separation system based on cold energy of liquefied natural gas. *J Xi'an Jiaotong Uni* 2007; 41: 122-4.
- [7] Kansha Y, Kishimoto A, Nakagawa T and Tsutsumi A. A novel cryogenic air separation process based on self-heat recuperation. *Sep Purif Technol* 2011; 77: 389-96.
- [8] Zhou H, Cai Y, Xiao Y, et al. Process configurations and simulations for a novel single-column cryogenic air separation process. *Ind Eng Chem Res* 2012; 51: 15431-9.
- [9] Fu C and Gundersen T. Recuperative vapor recompression heat pumps in cryogenic air separation processes. *Energy* 2013; 59: 708-18.
- [10] Jin T and Hu J. An air separation process by using LNG cold energy. *Gas Separation*. 2005; 5: 15-20.