

Available online at [www.sciencedirect.com](http://www.sciencedirect.com)**ScienceDirect**

Procedia Engineering 97 (2014) 1322 – 1331

---

**Procedia  
Engineering**

---

[www.elsevier.com/locate/procedia](http://www.elsevier.com/locate/procedia)

12th GLOBAL CONGRESS ON MANUFACTURING AND MANAGEMENT, GCMM 2014

## Optimum linkage for biped mechanism

Sushant Sukumaran<sup>a</sup>, R. Deivanathan<sup>b\*</sup><sup>a</sup>*M.Tech Student, SMBS, VIT University, Chennai Campus, India.*<sup>b</sup>*Associate Prof., SMBS, VIT University, Chennai Campus, India.*

---

### Abstract

Locomotion of a robot has been achieved with many possible solutions like legged or wheeled type. But the optimum linkage mechanism for a biped robot is yet to be specified for the purpose of walking. In this paper, different types of linkages depending upon their degree of freedom (DOF) have been compared and the best of them have been selected with help of ADMAS software. The biped mechanism consists of only two legs that are connected at the hip joint and are used for the locomotion of the robot/humanoid. This mechanism is selected based on parameters which are force developed in joints, trajectory of centre of mass (COM) of links and kinetic energy attained by all the links.

© 2014 The Authors. Published by Elsevier Ltd. This is an open access article under the CC BY-NC-ND license (<http://creativecommons.org/licenses/by-nc-nd/3.0/>).

Selection and peer-review under responsibility of the Organizing Committee of GCMM 2014

*Keywords:* Degree of freedom; gait; biped; center of mass.

---

### 1. Introduction

A biped robot is a robot that has two links, joint at the hip and which oscillate to produce a walking like motion/gait. The biped robot has been of keen interest for many researches as it is more complicated, and adds the robot with a more human like feature. With the help of many research conducted it has been inferred that legged locomotion is more efficient, versatile, and speedy than the one by wheeled and tracked vehicles when operated in a rough terrain [1].

---

\* Corresponding author. Tel.: +91-8754519412; +91-9789092344 ; fax: +044 3993 2555.

*E-mail address:* [deivanathan.r@vit.ac.in](mailto:deivanathan.r@vit.ac.in); [sushant.sukumaran2013@vit.ac.in](mailto:sushant.sukumaran2013@vit.ac.in)

The biped mechanism consists of only two legs that are connected to the hip joint and are used for the locomotion of the robot/humanoid. The most prominent problem with a biped walking mechanism is the stability of the complete robot. Different methods have been developed for stabilizing the robot both statically and dynamically [2] for example, stabilization of humanoid robot was attempted based on omnidirectional Visual Gyroscope, utilizing OcamCalib toolbox of Matlab [3].

The first one is the simple application of the inverse kinematics for the lower limb. Overall Centre of Mass (COM) of the body is selected as the end effector coordinates and the respective joint angles are calculated. This method has a disadvantage of not providing a single solution which leads to ambiguous conclusions if the authority of making the decision is left with the controller.

The second method is a simple concept of locating a point where the inertial and gravitational moment cancels out each other. This point is also called Zero Moment point (ZMP). The requirement for the stability of the robot is that, the ZMP should lie in the support polygon/convex hull. The locating of this point can be done effectively with the use of a force/torque sensor below the foot, which will give the real time position of the ZMP in different stages of the gait [4,5]. This is the most widely used method as it gives a better and easily calculated way for achieving a stable position of the robot/humanoid.

The third method is the Foot Placement Estimator (FPE). In this type, analytical methods are used to define the bounds of region of stability. The FPE with combination of the state machine generates a gait cycle without any pre-calculated trajectories.

The fourth method is the Inverted pendulum method, which is one the most basic method for the stabilizing of the robot. It is recently used with collaboration of control of ZMP [4,6]. During the single support stage, the bottom part/ the foot part is connected to the ground and the COM of the robot/humanoid is moved, giving an inverted pendulum system. We can further proceed by applying analytical methods to the system.

From this we can conclude that there are different methods for the stabilization of the robot/humanoid and no optimum method.

## 2. Methodology

Methodology followed consists of taking into consideration two different linkage systems which are most commonly found in nature, and analysing them for a better trajectory of the centre of gravity (COG) while in motion with the simple understanding that the whole system will be better stabilized if the path followed by the COG is a straight line.

For a biped robot/humanoid, two limbs can be considered under two categories in which the number of links and the number of joints differ respectively as shown in Table.1 [1, 7].

Table 1. Different categories based on number of links & joints.

Sr.No	Category	DOF/(limb)
1.	A- 3links and 3 joints	3
2.	B- 4 links and 4 joints	4

## 3. Part design

The software used for designing and modelling of parts is CATIA V5. This software is very user friendly and analysis of required parameters can be done easily.

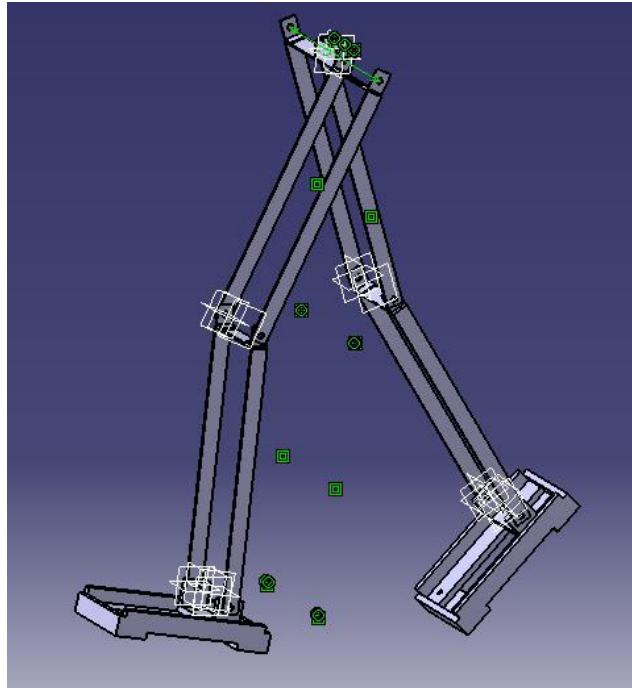

Fig.1 CAD model of the A-category

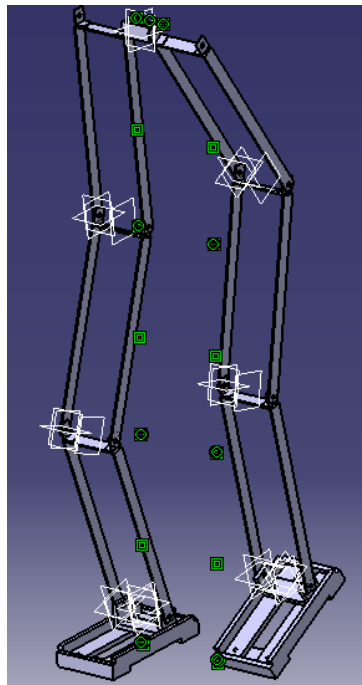

Fig.2 CAD model of the B-category

### 3.1. Category-A (3 links and 3 joints)

This linkage is the normal system in which 3 links and 3 joints are considered, replicating a normal human being's hind limb structure which consists of a femur, tibia and metatarsals and is in reference to Fig 1.

### 3.2. Category-B (4 links and 4 joints)

This linkage system consists of the most commonly observed linkage system in which there are 4 links and 4 joints which is visible in dogs, cats and many other mammals. They are also called as digitigrades. This is same in case of humans; the only difference is in the last third link to be divided into two links increasing the total number of link to 4 links.

Fig 2 shows the linkage which has more DOF leading to a more stable gait cycle of the complete mechanism.

## 4. Part simulation

For the simulation of both the categories we have used a multibody dynamics simulation software called as ADAMS software [8]. For the comparison criterion we have considered parameters like trajectory of the COM of linkages, force at the joints and kinetic energy attained by the linkages in both the cases. In this simulation only link mass has been considered.



Fig.3 ADAMS model of the A-category

### 4.1 Category-A simulation

For this category we have considered 3 links and 3 joints in which for the angle of rotation of the link at the two lower joints are controlled.

In Fig 3, the linkage system consists of 3 links replicating the human anatomy and consisting of a femur (pink;

link 1), tibia (light blue; link 2) and the foot (green and yellow; link 3).

The link 1 and link 2 are connected to each other with a revolute joint (JOINT\_1) and the link 2 and link 3 are connected with another revolute joint (JOINT\_2). Motion two both the joints have been given.

Fig 4 and Fig 5 depicts the force (N) developed in both joints when it is simulated for a period of 5 seconds. We can infer from the graph that there is a very slight change in the magnitude of force developed, the only difference between them is, with due course of time in JOINT\_1 the force decreases and in JOINT\_2 the force increases very marginally.

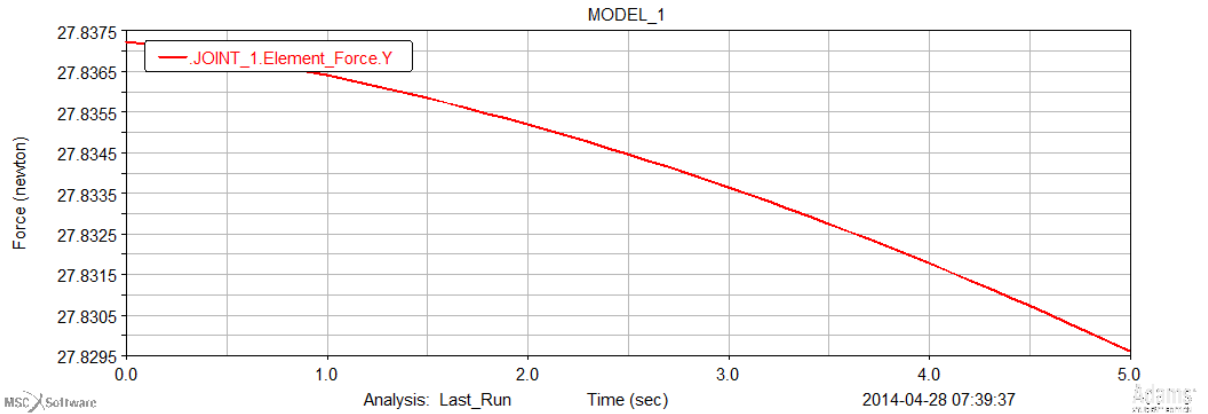

Fig.4 Force in JOINT\_1

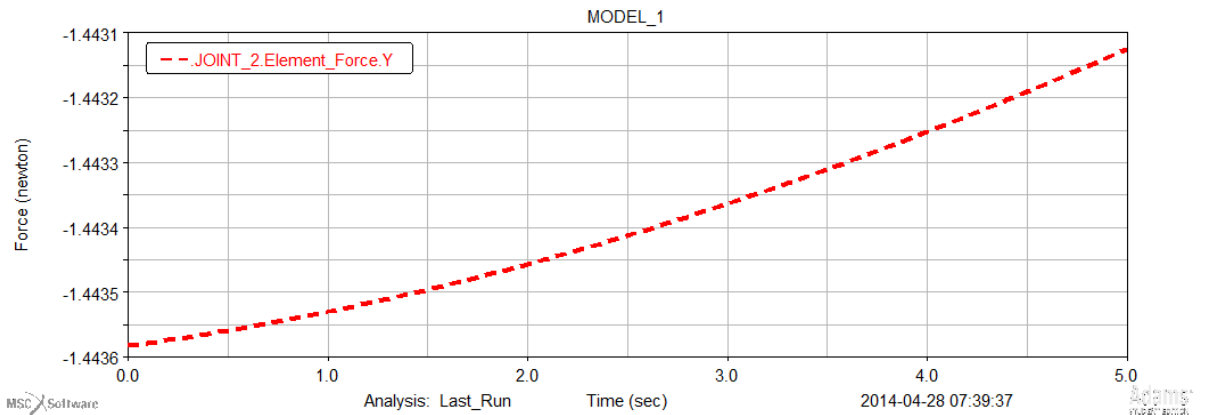

Fig.5 Force in JOINT\_2

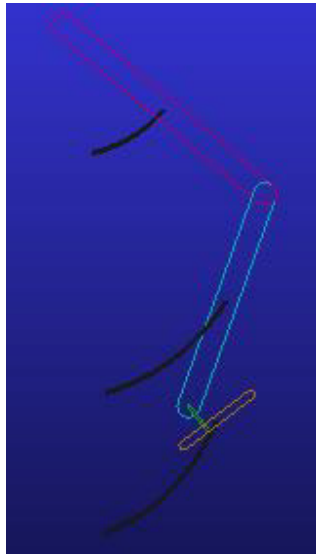

Fig.6 Trace of COM

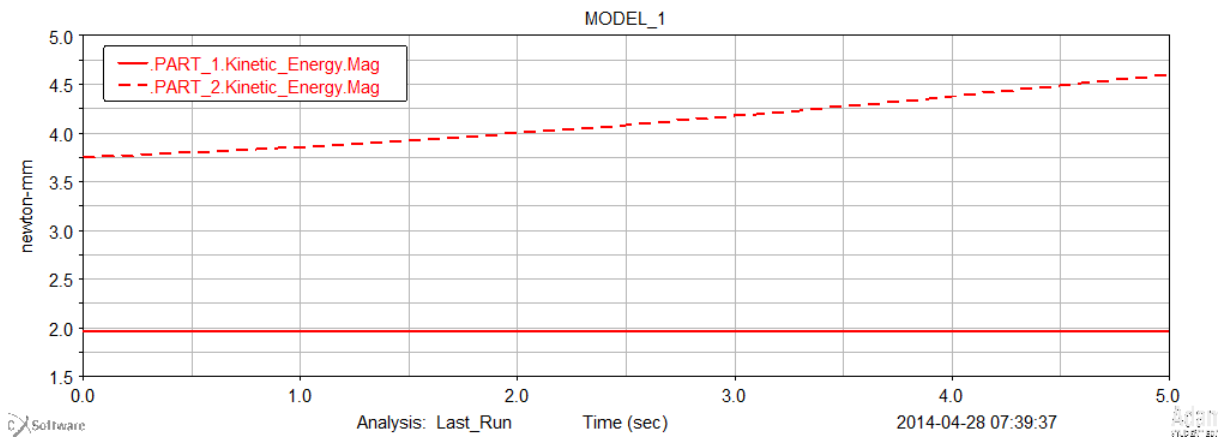

Fig.7 Kinetic energy of the 2 links

Fig 6 shows the path followed by the centre of mass (COM) of the most important three links which gives us a rough idea of how the centre of gravity (CG) will shift.

Fig 7 gives the kinetic energy (N-mm) in PART\_1 (link 1) and PART\_2 (link 2), and as we can see that in case of the link 1, the kinetic energy is increasing and in case of link 2, it remains same with a very minimal change.

In this simulation, for the category-A type, we have a control over the velocity of the joint; hence we will not be plotting the graph for displacement and velocity.



Fig.8 ADAMS model of the B-category

4.2 Category-B simulation

Fig 8 gives the pictorial representation of the linkage system. This category consists of 4 links and mainly 3 joints.

The link 1 and link 2 are connected to each other with revolute joint named as JOINT\_2. Link 2 and link 3 is joined by JOINT\_3 and for the link 3 and link 4, JOINT\_4. This linkage has more DOF which makes it more dexterous but at the same time makes the controlling procedure more complex as the number of input data increases.

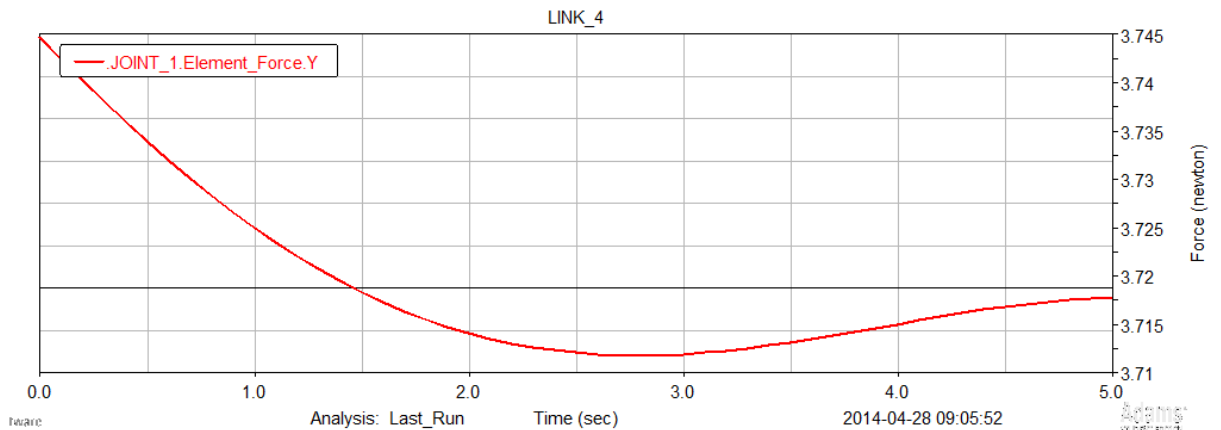

Fig.9 Force in JOINT\_1

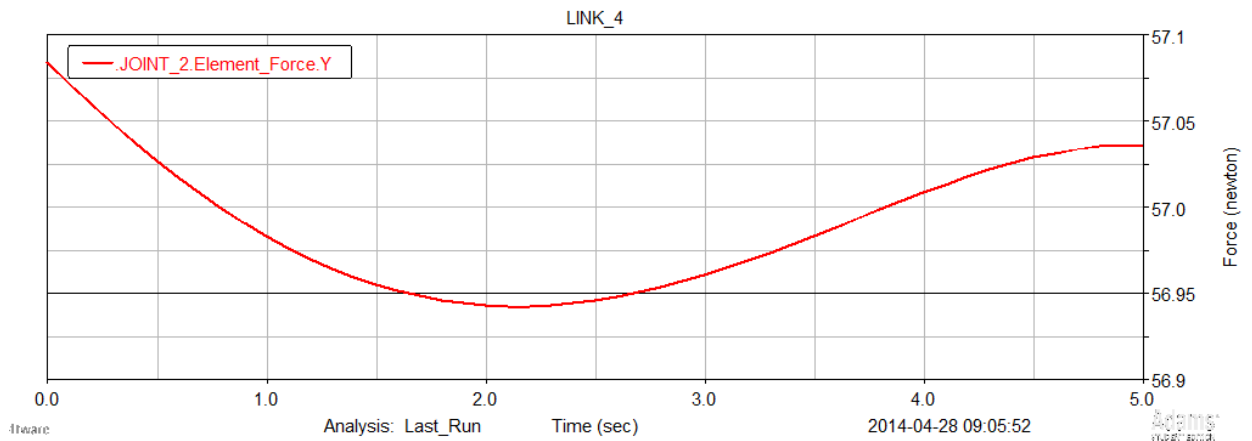

Fig.10 Force in JOINT\_2

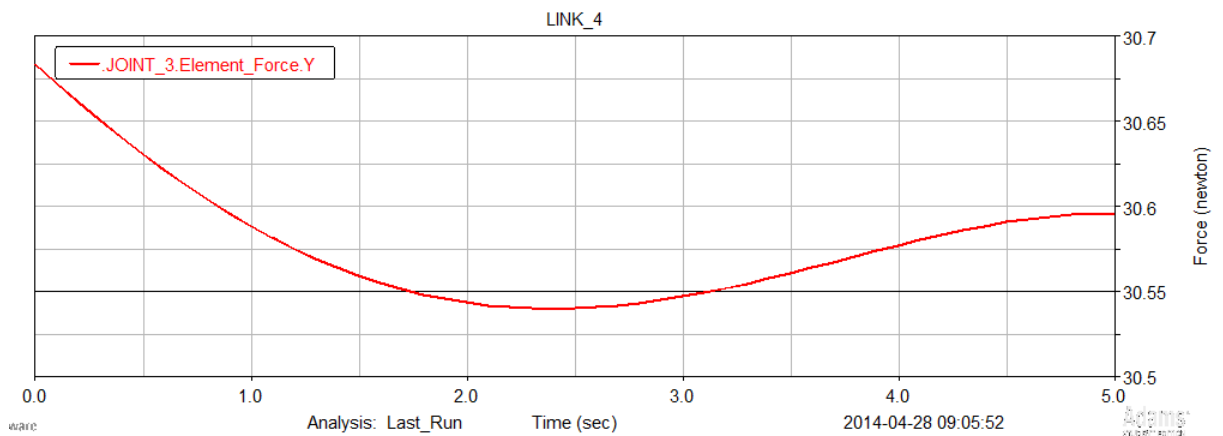

Fig.11 Force in JOINT\_3

The above three graphs (i.e. Fig.9, Fig.10 and Fig.11) represent the force developed in the three joints. We can infer that, all the joints follow the same path of change of force with the difference in the magnitude. This similar pattern of change in force gives rise to uniformity in the design and equal force induced.

The Fig 12 gives the trajectory followed by the COM of the different linkages. There is a similarity in the pattern of the path followed by each link. This similarity gives it a more stable COM.

From the Fig 13 we can understand that variation in the kinetic energy attained by the link 3 is the maximum when compared with the other two. The link 1 has a very stable and is close to zero value, whereas starting with a negative slope and then attaining a positive slope for kinetic energy is the case of the link 2.



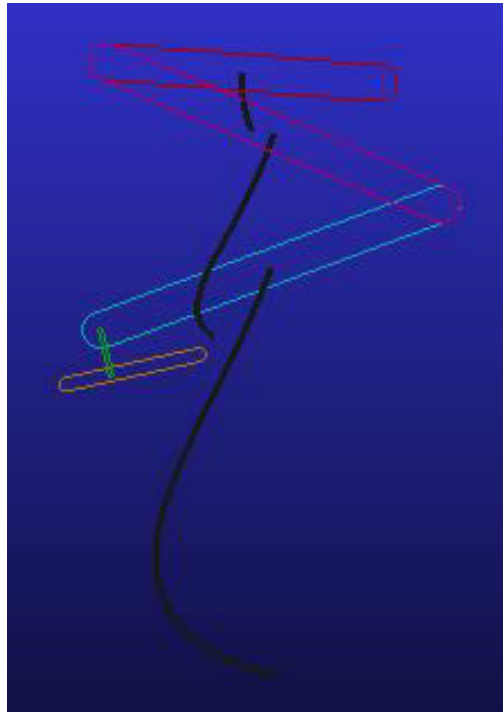

Fig.12 Trace of COM

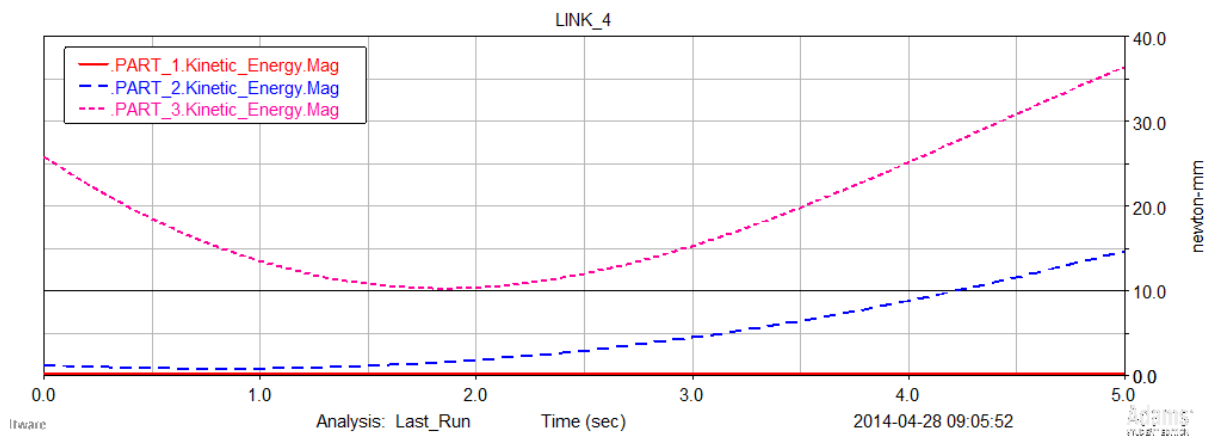

Fig.13 Kinetic energy of links

## 5. Result and discussion

From the above analysis done of the two different categories A and B, on the parameters of the force developed in the joints, trajectory of the COM and the kinetic energy developed in the links, we understand that:

- There is similarity in the force variation taking place in the joints for the B-category when compared with the A-category.

- The path followed by the COM of the links of B-category is a curve with a backward sweep as in the case of the A-category, it is in the forward direction.
- As there is more number of linkages in B-category, each link attains a particular amount of kinetic energy which leads to the overall increase in the total kinetic energy of the system.

## 6. Conclusion

Based on the results and discussion stated above we can make the following conclusions:

- The uniformity in the B-category due to the similarity in force variation in the joints leads to increase in stress and strain in overall structure. Whereas in case of A-category there is decrease in the force induced in the JOINT\_1 with gradual increase in JOINT\_2 which in a way counter acts the overall force.
- The forward sweeping movement of the COM of the A-category makes it easy for attaining required gait as the overall forward movement of the legs will give it a moment of inertia in the forward direction.
- More links will lead to more kinetic energy attained leading to very high moment of inertia which needs to be controlled to attain stability, hence more complexity in the controlling the legs.

From the above drawn conclusions, we can state that A-category is the most suited linkage system for biped mechanism with advantages of less complexity in controlling, assisted forward locomotion and less force development in joints.

## References

- [1] Jun-Ho Oh, David Hanson, Won-Sup Kim, Il Young Han, Jung-Yup Kim, Ill-Woo Park, Design of Android type Humanoid Robot Albert HUBO, in: IEEE/RSJ International Conference on Intelligent Robots and Systems, Beijing, China, 2006, pp. 1428-1433.
- [2] C. Chevallereau, D. Djoudi and J.W. Grizzle, Stable Bipedal Walking with Foot Rotation Through Direct Regulation of the Zero Moment Point, IEEE Transactions on Robotics, 24(2) (2008) 390-401.
- [3] Matteo Finotto, Emanuele Menegatti, Humanoid Gait Stabilization based on Omnidirectional Visual Gyroscope, in: Proceedings of the 4th Workshop on Humanoid Soccer Robots, IEEE-RAS Intl. Conf. On Humanoid Robots, Paris(France), 2009, pp. 52-59.
- [4] Shuuji Kajita, Mitsuharu Morisawa, Kensuke Harada, Kenji Kaneko, Fumio Kanehiro, Kiyoshi Fujiwara and Hirohisa Hirukawa, Biped walking Pattern Generator allowing Auxiliary ZMP Control, in: Proceedings of IEEE/RSJ International Conference on Intelligent Robots and Systems, Beijing, China, 2006, pp. 2993-2999.
- [5] Dorian Scholz, Martin Friedmann, Oskar von Stryk, Fast Robust and Versatile Humanoid Robot Locomotion with Minimal Sensor Input, in: Proceedings of the 4th Workshop on Humanoid Soccer Robots, IEEE-RAS Intl. Conf. On Humanoid Robots, Paris(France), 2009, pp. 66 - 72.
- [6] Shuuji Kajita, Mitsuharu Morisawa, Kanako Miura, Shin'ichiro Nakaoka, Kensuke Harada, Kenji Kaneko, Fumio Kanehiro and Kazuhito Yokoi, Biped Walking Stabilization Based on Linear Inverted Pendulum Tracking, in: IEEE/RSJ International Conference on Intelligent Robots and Systems, Taipei, Taiwan, 2010, pp. 4489 - 4496.
- [7] Brett C. Brown, Design of a single degree of freedom biped walking mechanism, Undergraduate Honors Thesis, The Ohio State University, Department of Mechanical Engineering, 2006.
- [8] ADAMS/Insight Trainig Guide, 2003.