

Available online at [www.sciencedirect.com](http://www.sciencedirect.com)**SciVerse ScienceDirect**

Procedia Technology 3 (2012) 316 – 323

**Procedia**  
Technology

## Adaptive Electrical Stimulation to Improve In-Vitro Cell Growth

Luis Niño de Rivera<sup>a\*</sup>, Ernesto Paredes Martínez<sup>a</sup>, Daniel Robles Camarillo<sup>b</sup>,  
Wilfrido Calleja Arriaga<sup>c</sup>

<sup>a</sup>National Polytechnic Institute of Mexico (IPN), ESIME-UPC. México D.F.

<sup>b</sup>Polytechnic University of Pachuca

<sup>c</sup>National Institute of Astrophysics, Optics and Electronics, Puebla, Mexico

---

### Abstract

An adaptive system is used to stimulate electrically (In-Vitro) muscle vagina cells and epithelial rabbit bladder cells with external electrical stimulation ES. Waveform stimulation is synthesized from both: A specific known action potential or by a set of independent ionic potentials conforming a multi output system. Each ionic potential is the output of a set of FIR filters in which the coefficient adaptation is carried out by using a time varying step size normalized LMS (NLMS) algorithm. The adaptive system output stimulates in-vitro culture cells emulating biological neurotransmitters action. Electrical stimulation (ES) shows that cells under test grow faster than non-stimulated ones, observing bigger cell viability in stimulated cells than non stimulated. The objective of the experiment is to analyze the effect of external electrical stimulation ES on confluence and cell viability in culture cells by MTT (3-[4,5-Dimethylthiazol-2-Yl]-2,5-diphenyl-tetrazolium bromide) assays <sup>[A]</sup>.

© 2012 Published by Elsevier Ltd. Open access under [CC BY-NC-ND license](http://creativecommons.org/licenses/by-nc-nd/3.0/).

**Key Words:** Culture cells, action potential, adaptive filter, electric cell stimulation

---

### 1. Introduction

Action potential is a short-lasting event in which the electrical membrane potential of a cell rapidly rises and falls, following a consistent trajectory. Action potentials occur in several types animal cells, called excitable

---

\* Corresponding author. Tel.:5-5556562058; fax: 5-5556562058.  
E-mail address: [luisninoderivera@gmail.com](mailto:luisninoderivera@gmail.com)

cells, which include, muscle and endocrine cells. In neurons, they play a central role in cell-to-cell communication. In other types of cells, their main function is to activate intracellular processes. In muscle cells, for example, an action potential is the first step in the chain of events leading to contraction. Action potentials in neurons are also known as "nerve impulses" or "spikes", and the temporal sequence of action potentials generated by a neuron is called its "spike train". A neuron that emits an action potential is often said to "fire". Special types of voltage-gated ion channels embedded in a cell's plasma membrane generate action potentials as indicated by Constance Hammond. These channels are shut when the membrane potential is near thirsting potential of the cell, but they rapidly begin to open if the membrane potential increases to a precisely defined threshold value. When the channels open, they allow an inward flow of sodium ions, which changes the electrochemical gradient, which in turn produces a further rise in the membrane potential. This effect causes then more channels to open, producing a greater electric current, and so on. The process proceeds explosively until all of the available ion channels are open, resulting in a large upswing in the membrane potential. The rapid influx of sodium ions causes the polarity of the plasma membrane to reverse, and the ion channels then rapidly inactivate. As the sodium channels close, sodium ions can no longer enter the neuron, and they are actively transported out of the plasma membrane. Potassium channels are then activated, and there is an outward current of potassium ions, returning the electrochemical gradient to the resting state. After an action potential has occurred, there is a transient negative shift, called the after hiper-polarization or refractory period, due to additional potassium currents. This is the mechanism which prevents an action potential traveling back.

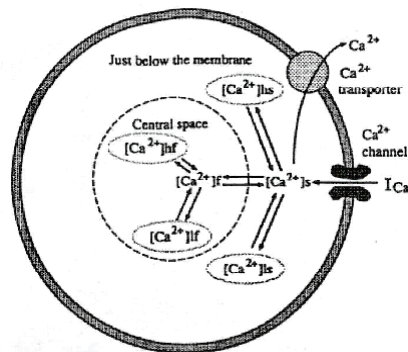

**Figure 1** Scheme of ionic channels at the cell membrane

Previous studies have shown that ES produces regeneration in neurons, promotes the speed and accuracy of motor axonal function regeneration, promoting the reinnervation of appropriate muscle pathways by femoral motor nerves, just to name a few, Abdulhakeem., et al or Thomas M, Brushart., et al. All these suggest that ES of neural tissues seems to have a neuron protective action. Cell Engineering is a very recent and promising research field which efforts look for the development of efficient artificial tissue growth methods, see Atlantida M, Raya-Rivera et al. The main idea in this work is to get an artificial external procedure to induce equivalent biological action potentials in the culture cells to open and close their ionic channels in order to stimulate membrane interchanges of ionic currents with its environment.

External electric fields applied in culture cells interact with ionic fields inside cells forcing their ionic channels interchanging sodium, calcium and potassium through the ionic channels, Colin D. Mc Gaig., et al . We show in Fig.1 a scheme of the effects of external action potential on cells opening and closing cell membrane channels. According to Constance Hammond we can observe action potential read on the cell membrane where the Na<sup>+</sup> channels are opened during the polarization time from -70mV to + 40 mV; Na<sup>+</sup> channels keeping inactive in +40 mV; K<sup>+</sup> channels are opened from +40 mV to -100 mV; in -100 mV Na<sup>+</sup> channels are closed again, and finally, K<sup>+</sup> channels are close in rest potential (-70 mV).

Electrical stimulation applied in-vitro cells produces similar effects than natural neurotransmitter, then it is possible to open and close ionic channels by the action of properly selected external action potential. In order to fire a specific ionic channel we require the generation of specific electrical action potential.

## 2. Methodology

A Cell is a very complex processor; we show in figure 1 a simplified representation of the intracellular cycle. The calcium ionic current depends, among other variables, on the open/close cycle of the ionic  $Ca^{2+}$  channel. Equation (1) is used to describe the performance the ionic current cell, including its resting state,  $V_{rest}$  is the value at which the sum of membrane currents (active pump currents included) is equal to zero. This value represents a condition of electrical equilibrium for the membrane since the neither current does nor change the total charge and hence they potential are also not changing. The equilibrium value of the potential, or resting potential  $V_{rest}$  is thus given by:

$$g_n(V_{rest} - E_k) + g_{Na}(V_{rest} - E_{Na}) + g_{Ca}(V_{rest} - E_{Ca}) + g_{Cl}(V_{rest} - E_{Cl}) + \dots g_n(V_{rest} - E_k) + i_{Na/k} + i_{Ca} + \dots = 0 \dots (1)$$

where  $i$  is the current generated by operation of the various ionic pumps, and  $i$  may depend upon  $V$ , ionic concentration. The ellipses indicate possible addition of other channels and pumps. It should also be noted that for each ionic current there are often several different type of channel with distinct non-linear conductance and gating properties, in the present simplified scheme, there are all lumped together into a single species.

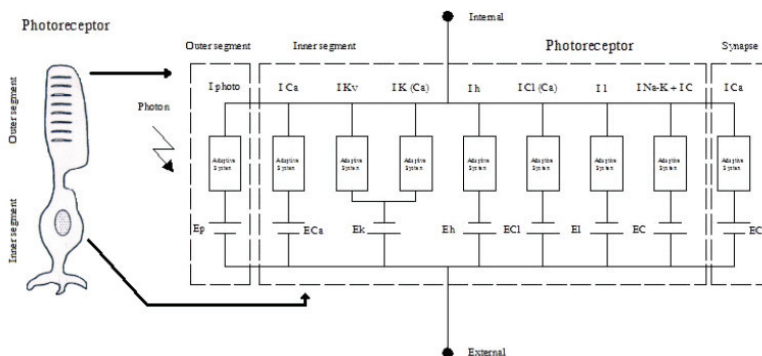
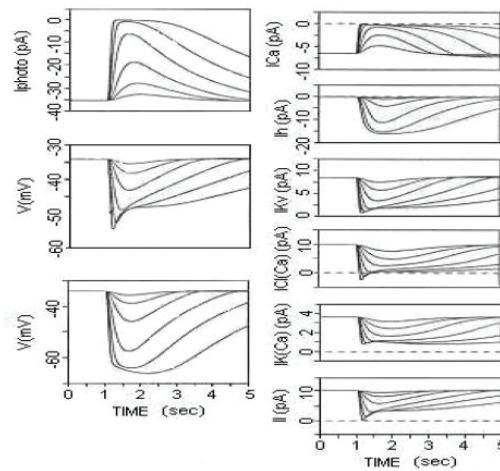

Fig. 2. Adaptive ionic cell current model.

According to equation (1) we propose a new model to represent each ionic current by a set of adaptive filters as indicated in figure 2. Each adaptive filter estimates the desired ionic current which parameters are calculated by the well-known Least Mean Square (LMS) adaptive algorithms. Each current source is then the output of an adaptive FIR filter that estimates each ionic current from the set of known or desired  $d(n)$  ionic currents as indicated in Figure see Usui et al., and Luis Niño-de-Rivera et al.,



**Fig. 3.** A different set of time varying ionic currents in cone cell proposed by Usui

The desired action potential to stimulate in vitro culture Cells is sketched by a friendly software. We show in Fig. 4. A friendly software display that let choose any action potential to be estimated by the LMS algorithm.

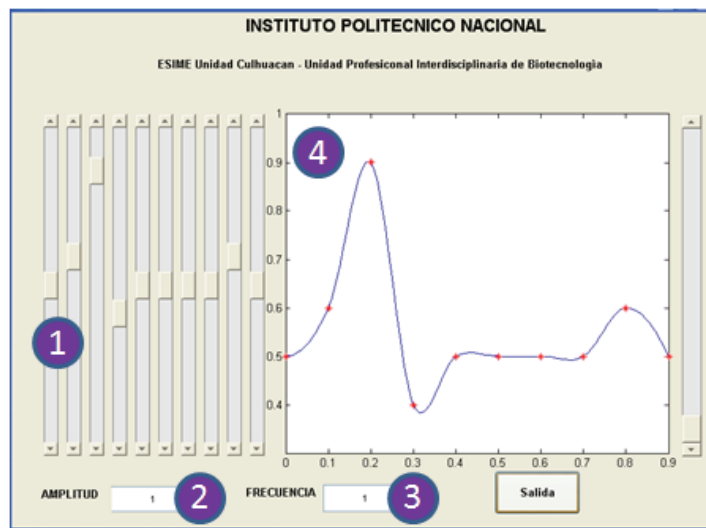

**Fig. 4.** A friendly software sketches the desired any ionic current to be estimated by FIR filters.

The selected waveform is estimated by a set of adaptive filters in identification configuration as indicated in Fig. 5. The unknown block represents the desired action potential  $d(n)$  to be estimated by an adaptive filter. The coefficients of the FIR filter estimated by the NLMS algorithm are the impulse response of the desired signal  $d(n)$  sketched by virtual sliders in figure 4. A detailed discussion about NLMS algorithm is presented by Luis Niño-de-Rivera et al. Then the proposed adaptive system can stimulate culture cells which waveforms and parameters are a copy of biologically ionic currents. Once the desired  $d(n)$  action potential is defined, we model the action potentials by both: a set of continues polynomials, and a set of discrete values. The curves are processed such statistical data to obtain a model through of the mean square statistical

regression method. Then we get a group of data that allow the description of the action potential by three continuous polynomial as indicated in table 1, see Daniel Robles et al. Each polynomial in table 1 is represented by a set of weights W1, W2 ... Wn, in Fig. 7. The intensity variations are adjusted by the corresponding “kn” constant factor (waveform voltage amplitude). The system’s adaptation is carried out using the normalized convergence algorithm NLMS shown in equation (2).

**Table 1.** Mathematical model parameters

Time intervals	Section 1	Section 2	Section 3
Start time (ms)	0	36.95	71.73
End time (ms)	39.13	69.56	100
Section	Fitting polynomials		
1 <sup>st</sup>	-0.1517-0.1683t+0.1234 t <sup>2</sup> -0.1798 t <sup>3</sup> +0.1293 t <sup>4</sup>		
2 <sup>nd</sup>	(1x10 <sup>4</sup> ) * (1.1975-0.1024t+0.0032 t <sup>2</sup> -0.000012 t <sup>3</sup> )		
3 <sup>rd</sup>	(1x10 <sup>4</sup> ) * (3.0895-0.1463t-0.0026t <sup>2</sup> -0.00001346t <sup>3</sup> )		

$$w(n + 1) = w(n) + \frac{\alpha}{x(n) * x(n)^T} * x(n) * e(n).....(2)$$

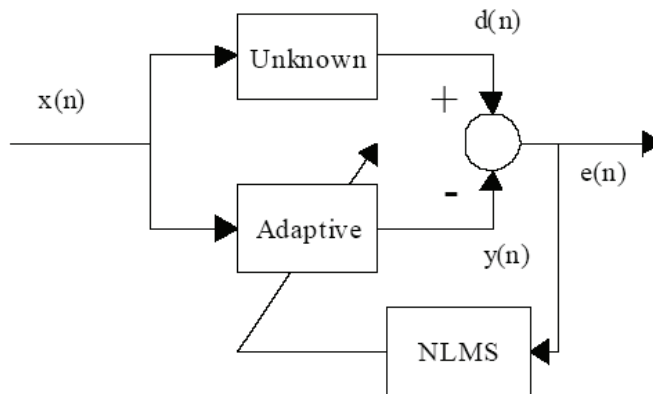

**Fig. 5.** Adaptive model for action potential cells estimation.

Any new time varying action potentials can be generated again by a set of FIR filterers. The stimulation system can estimate sixteen different action potential simultaneously to fire sixteen outputs. The system

has a friendly software interface shown in Figure 7 that let define a set of 16 d(n) ionic or action potential waveforms by the simple positioning of virtual sliders. The display shows the output with 16 previously selected waveforms

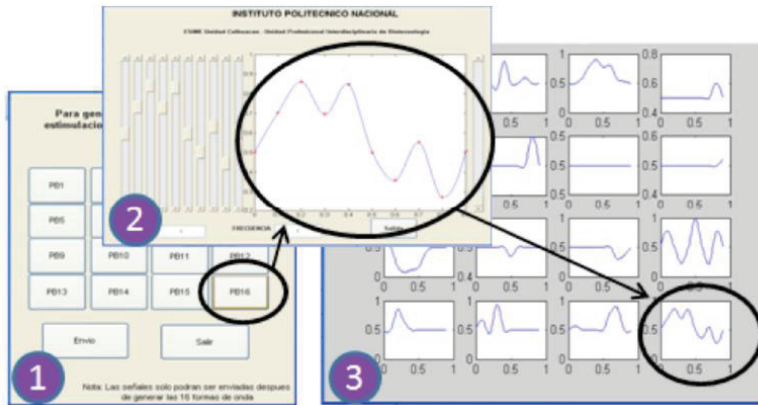

Fig. 7. Software interface to define desired equivalent action potential

### 3. Results

EXPERIMENT 1 and 2:

Cells type: muscle vagina cells.

Initial cells counting: 900,000.

Stimulation parameters: 200 Hz, signal amplitude 400 mVpp.

1. In Fig. 8, the cell concentration at the beginning of experiment 1 there were 900,000 cells. After 3 days of culture, muscle stimulated cells reached 1,430,000 cells (530,000 more cells), while CONTROL cells fell from 900,000 to 620,000 cells.

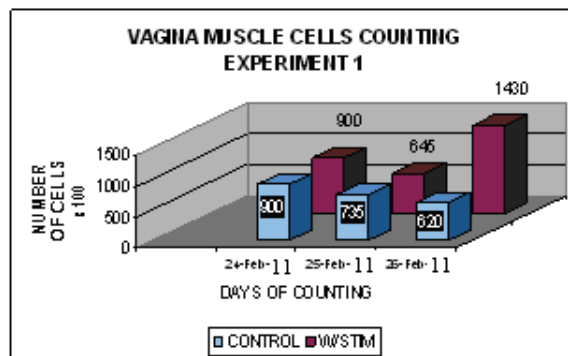
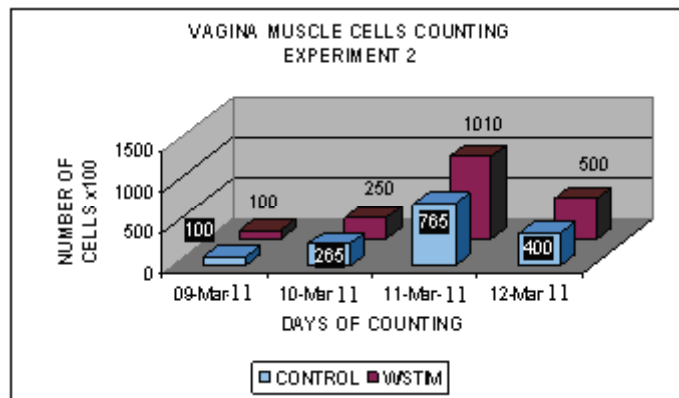

Fig 8. Results of first experiment with vagina cells (Number of cells x100).



**Fig 9.** Results of second experiment.

In Fig. 9, the cell concentration at the beginning of experiment was 100,000. After 4 days of culture, muscle stimulated cells reached 500,000 cells (meaning 5 times more), while CONTROL cells reached 4 times more (400,000 cells).

#### 4. Discussion and conclusions

These experiments reported show that cell growth is related with frequency stimulation, voltage amplitude, and passing number, seems to be that 10 Hz in passing 3 gives better results than 3.3 Hz in passing 2. A future application of ES on muscle and epithelial bladder cells is to treat neurogenic bladder in humans, as an alternative to solve urinary incontinence by improving elastic properties in neo-tissue, see Mou'ine et al., and Erick Mendoza and Carrillo et al., [5, 6]. More experiments are necessary to find the optimum parameters in frequency and amplitude for the stimulus signal. ES on bladder cells has some advantages like: 1) Reduce bladder neo-tissue timing culture, 2) We have evidences of better speed and confluence of cell growing. Future research is required to understand properly other collateral effects in cells performance.

#### Acknowledgements

The authors of this paper thank to the National Council of Science and Technology of Mexico (CONACyT) and to the National Polytechnic Institute of México for the provided support to realize this work.

## References

- [1] Constance Hammond. *Cellular and Molecular Neurophysiology*. Third edition. Academic Press. 2008
- [2] Abdulhakeem., et al. Brief Electrical Stimulation Promotes the Speed and Accuracy of Motor Axonal Regeneration. *The Journal of Neuroscience* , April 1, 2000, pp. 2602-2608.
- [3] Thomas M, Brushart., et al. Electrical Stimulation Promotes Motoneuron Regeneration without Increasing Its Speed or Conditioning The Neuron. *The Journal of neuroscience* August 1, 2002, pp. 6631-6638.
- [4] Colin D. McGaig., et al. Controlling Cell Behavior Electrically Current Views and Future Potential. *Physiol Rev.* 85: 943-978, 2005.
- [5] Atlantida M, Raya-Rivera., Carlos Baez., Anthony Atala., and James J, Yoo. Tissue Engineered Testicular Prosthesis with Prolonged testosterone Release
- [6] Daniel Robles-Camarillo., Luis Niño de Rivera., H. Quiroz Mercado., M. J. López Miranda., V. Ponomaryov., E. Escamilla, G. Garcia., and C. Herrera. Cornea's Stimulator Electronic System. *Biosignal* 2008.
- [7] Luis Niño-de-Rivera, Héctor Pérez Meana, Edgar Sánchez-Sinencio. A Modular Analog NLMS Structure for Adaptive Filtering. *Analog Integrated Circuits and Signal Processing*, 21, 127-142 (1999).
- [8] Usui., et al. Physiological Engineering Model of the Outer Retina *Progress in Retinal Research*. Vol. 7, (1997), pp. 15-46. Jaouhar.
- [9] Mou'ine., Daniel Brunner., and Zied Chtourou. Design and Implementation of a Multichannel Urinary Incontinence Prosthesis. *Proceedings of the 22<sup>nd</sup> Annual EMBS International Conference*. July 23-28, 2000, Chicago IL, pp. 1100-1103.
- [10] Erick Mendoza Carrillo., Roberto Vega Serrano., Gildardo Navarro Peña., and Néstor Ceballos C. Electrical Stimulation, Applications and News in Urology. *Urinary Mexican College*. Vol. XVII, No. 4. October-December 2002, pp. 207-214