

15p

N63-14326

NASA TN D-1673

code 1

NASA TN D-1673



# TECHNICAL NOTE

D-1673

## A SURVEY OF LARGE SPACE CHAMBERS

R. T. Hollingsworth

Goddard Space Flight Center

Greenbelt, Maryland

NATIONAL AERONAUTICS AND SPACE ADMINISTRATION

WASHINGTON

April 1963

554164

20p

# A SURVEY OF LARGE SPACE CHAMBERS

by

R. T. Hollingsworth  
*Goddard Space Flight Center*

## SUMMARY

14626

Construction has been authorized for a number of large thermal-vacuum chambers to simulate orbital altitudes in the environmental testing of complete spacecraft. The proposed facilities shall be capable of simulating the low temperatures, solar and earth radiation, and vacuum of outer space.

We have outlined in this report the individual specifications and capabilities of each of the proposed space simulation facilities. Since the field of space simulation is growing rapidly, it is recognized that this survey will be out of date upon issue.

# A SURVEY OF LARGE SPACE CHAMBERS

by

R. T. Hollingsworth  
*Goddard Space Flight Center*

The need for ground-test facilities which simulate environments encountered at orbital altitudes has caused the government and private industry to authorize and construct large thermal-vacuum chambers for testing complete spacecraft in many combined environments.

Since the major portion of a spacecraft's operational life is spent in a vacuum, high reliability must be assured by ground testing in a similar environment prior to launching. Some of the principal space environment factors are: the low temperatures, solar and earth radiation, ionizing radiation, meteoritic impacts, and zero gravity. Current technological limitations preclude the simulation of the last three factors in large space chambers. The remaining factors are chiefly concerned with the thermal cycles, heat balance, and temperature extremes experienced by the spacecraft.

While scientific theory and analytical procedures permit design calculations, the many simplifying assumptions must be verified by testing of the final complex structure. It is often necessary to control the spacecraft temperature within a few degrees centigrade for proper operation of scientific instruments and experiments; this is achieved by regulation and ejection of the heat generated by internal power sources. The complexity of this problem with large spacecraft is so great that experimental verification must be made under test conditions simulating outer space.

The current thermal-vacuum techniques employed at the Goddard Space Flight Center include the following:

1. Uniform soak temperature. – For spinning satellites of simple geometric configuration, with very low power dissipation, a uniform soak test may be sufficient. Even for complex systems, it is felt that a soak test is required as a preliminary test to provide a well defined datum plane.

2. Predicted temperature contour reproduction. – This method involves using a combination of cold walls and lamps to reproduce the temperatures predicted (by the thermal design) in several important regions of the spacecraft. Usually the spacecraft is brought to "power-off" temperatures, and the inputs are held constant when the power is turned on. This technique was employed with Explorer XII. In this test, realistic temperature gradients are produced to verify performance.

The following will briefly illustrate the above: The solar aspect for Explorer XII was 150 degrees in September, 1961. The solar aspect for March, 1962 (shown in position 2 on Figure 1) was

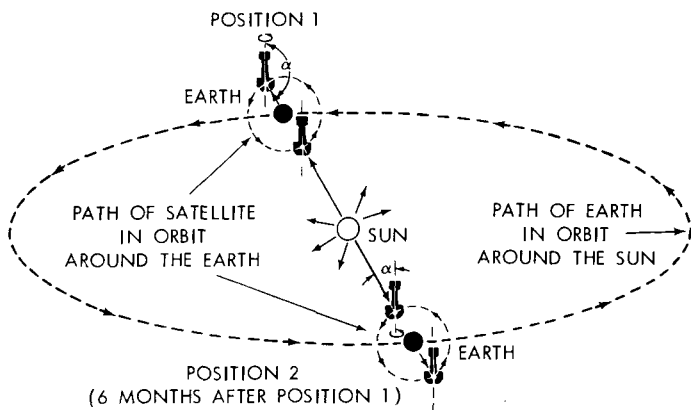

Figure 1—Relative positions of sun and satellite at different times of year.

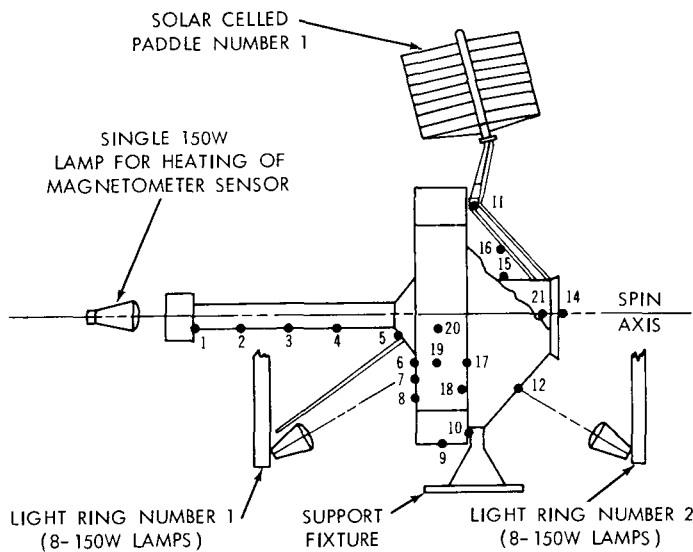

Figure 2—Thermal-vacuum aspect tests. Numbers designate thermalcouple stations.

30 degrees. Figure 2 shows the positioning of the lamps for the thermal-vacuum testing of Explorer XII. The two aspect tests were chosen because the main instrumentation compartment is located in the octagon, while the transmitter section is near the base of the spacecraft. Since these two locations will alternately "see" the direct solar radiance and the cold of space, the thermal-vacuum test was designed to observe the thermal gradients through the spacecraft and their effect, if any, on the subsystems.

As spacecraft become more sophisticated, more accurate simulation of the expected environment will be required. Thus, many facilities now planned or under construction will include solar simulation and cryogenic wall temperatures.

In light of the foregoing, it is interesting to review the facilities under consideration for the spacecraft of the future. The following pages present illustrations and tabular summaries of a number of such facilities.

SPACE SIMULATION FACILITY  
REPUBLIC AVIATION CORPORATION  
FARMINGDALE, LONG ISLAND, NEW YORK

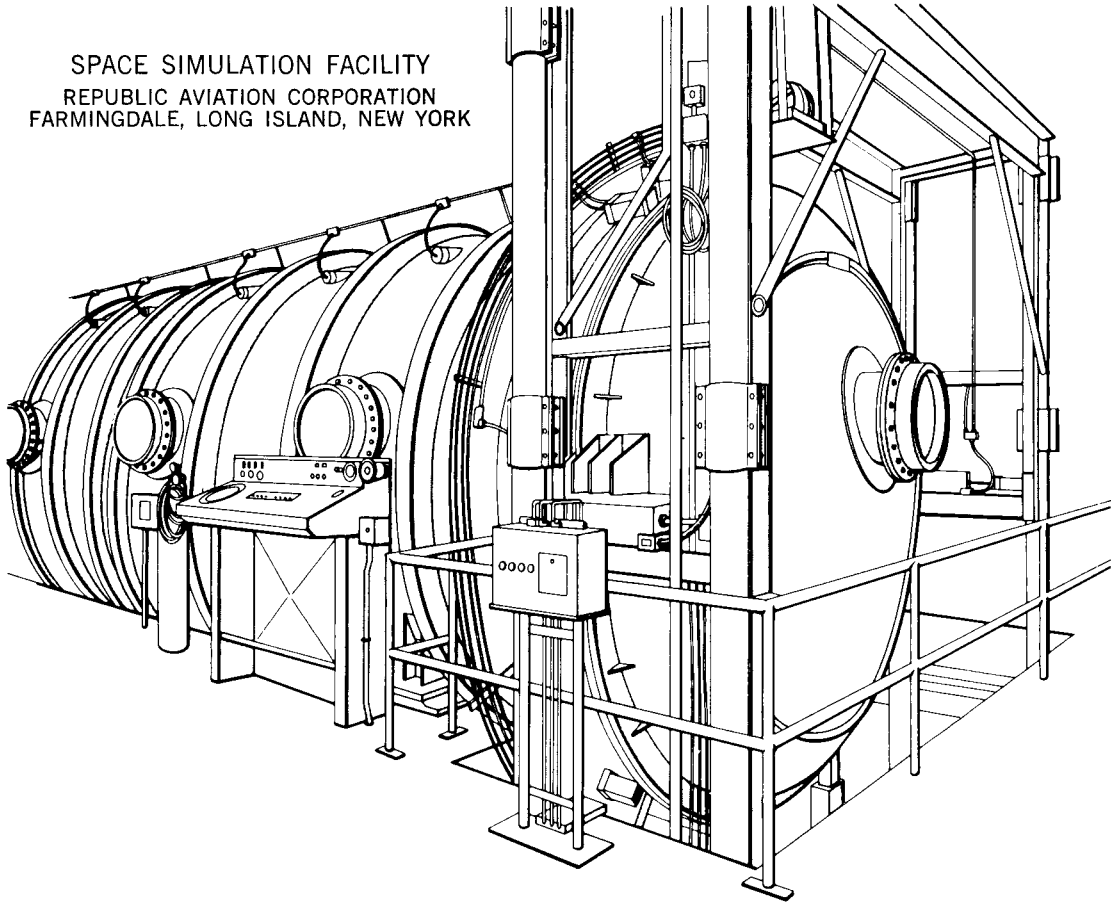

Construction:

Overall dimensions: 13 ft diameter x 30 ft long.  
Construction material:  
Shell: 304 Stainless Steel.  
Work space dimensions:  
Entry lock: 13 ft diameter x 8 ft long.  
Operating lock: 13 ft diameter x 18 ft long.

Pressure:

Ultimate pressure:  $8.8 \times 10^{-7}$  mm-Hg.  
Time to achieve ultimate pressure: 3 hours.  
Pumping system: Electronic gettering and blower system.

Temperature:

Temperature range: Under evaluation.  
Thermal system: Under evaluation.

Cryogenics:

LN<sub>2</sub> panel area: Under evaluation.  
He panel area: Under evaluation.

Solar Simulation:

Area illuminated: 10 ft diameter  
Maximum intensity: 250 watts/ft<sup>2</sup>.  
System type: Xe lamps.

Other Environment Capabilities:

A sinusoidal vibration system with a 30,000-pound force output is being installed.

Systems Contractor:

Design: Tenney Engineering, Inc.  
Fabrication: Tenney Engineering, Inc.

Operational Date:

September, 1961 (vacuum).

HIVOS (HIGH VACUUM ORBITAL SIMULATOR)  
LOCKHEED AIRCRAFT CORPORATION  
SUNNYVALE, CALIFORNIA

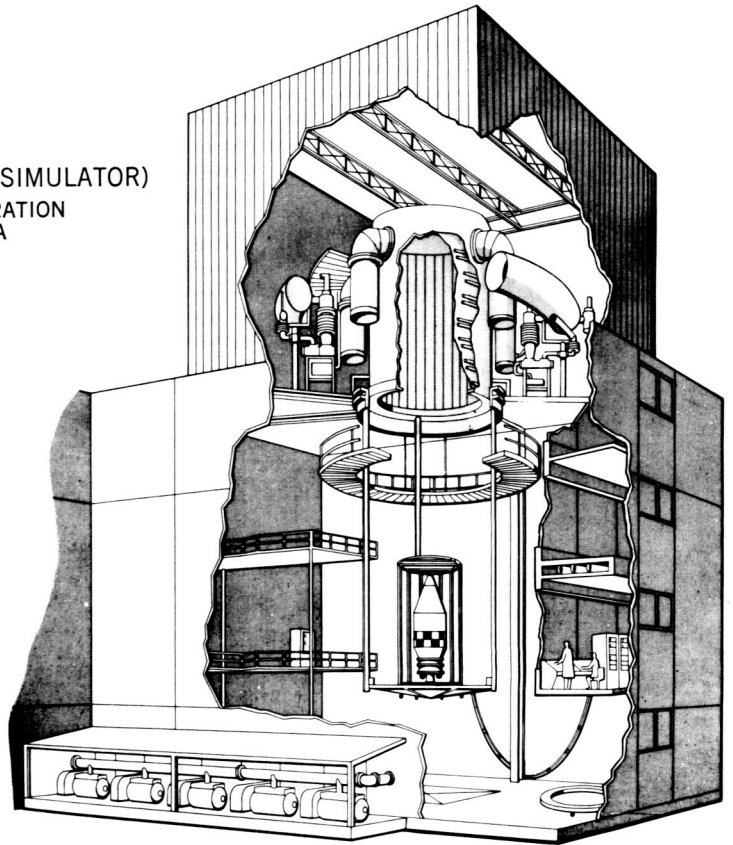

Construction:

Overall dimensions: 18 ft inside diameter x 20 ft high.

Construction materials:

Shell: 304 Stainless Steel.

Shroud: extruded aluminum.

Work space dimensions:

Initial configuration for 5 ft diameter x 15 ft vertically mounted vehicle.

Pressure:

Ultimate pressure:  $1 \times 10^{-8}$  mm-Hg.

Time to achieve ultimate pressure: 4 hours.

Pumping system: Twenty-two 32-inch oil diffusion pumps backed by diffusion ejector and mechanical pumps.

Temperature:

Temperature range: Shell — 273°F, ambient to +375°F.

Thermal system: Circulating Dowtherm-A.

Cryogenics:

LN<sub>2</sub> panel area: 5800 square feet.

Heat Flux:

Present configuration: 5 ft diameter x 15 ft with 1000 Btu/hr/ft<sup>2</sup>.

System type: Quartz lamps backed by alum. reflectors, computer programmed for simulated orbital motion.

Systems Contractor:

Design: Consolidated Vacuum Corporation.

Fabrication: Consolidated Vacuum Corporation (prime).

Operational Date:

February 1, 1962.

RCA SPACE CENTER  
RADIO CORPORATION OF AMERICA  
PRINCETON, NEW JERSEY

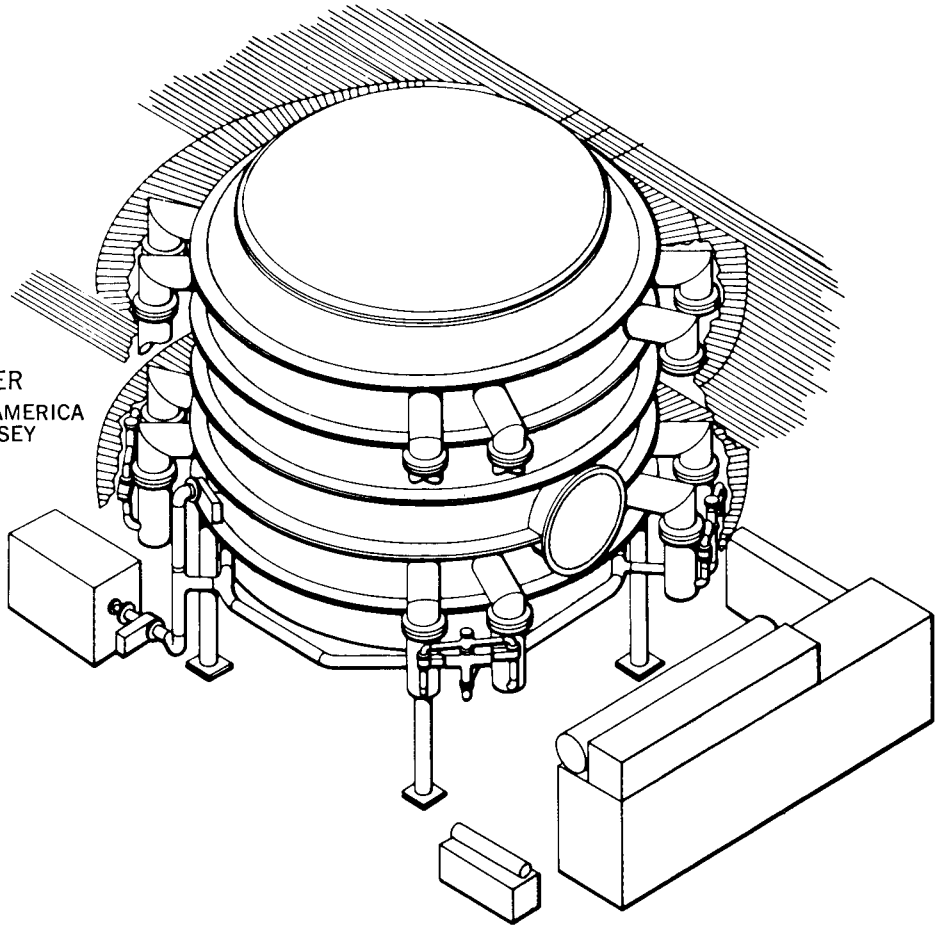

Construction:

Overall dimensions: 30 ft diameter x 34 ft high.  
Construction materials:  
Shell: 304 Stainless Steel.  
Work space dimensions: 24 ft diameter x 20 ft.

Pressure:

Ultimate pressure:  $10^{-7}$  or better,  $5 \times 10^{-6}$  mm-Hg  
with test vehicle.  
Time to achieve ultimate pressure: 24 hours.  
Pumping system: Sixteen 32-inch oil diffusion  
pumps backed by booster and  
mechanical pumps.

Temperature:

Temperature range:  $-100^{\circ}$  F to  $+250^{\circ}$  F.  
Thermal system: Cascade Freon 13 brine  
system and immersion  
electric heaters.

Cryogenics:

Forecasted for 1962: Operational  $\text{LN}_2$  open  
cycle.

Solar Simulation:

Forecasted for 1963.

Other environment capabilities of this chamber:

28,000 vibration potential.

Systems Contractor:

Design: RCA Major Systems Division.  
Fabrication: Chicago Bridge and Iron Company.

Operational Date:

November, 1961.

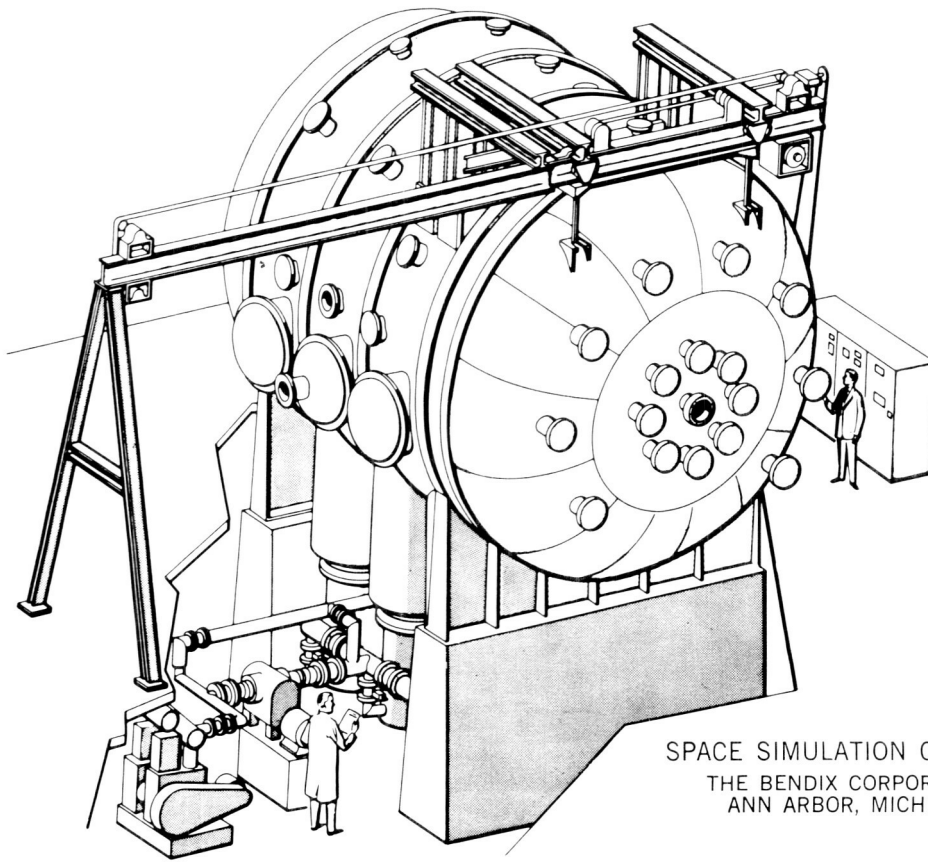

SPACE SIMULATION CHAMBER  
THE BENDIX CORPORATION  
ANN ARBOR, MICHIGAN

Construction:

Overall dimensions: 20 ft diameter x 27 ft long.

Construction materials:

Shell: 304 Stainless Steel.

Shroud: 304 Stainless Steel.

Work space dimensions: 18 ft diameter  
x 20 ft long.

Pressure:

Ultimate pressure:  $4.8 \times 10^{-8}$  mm-Hg with  
cold wall.

Time to achieve ultimate pressure: 11-12 hours.

Pumping system: Six 32-inch oil diffusion  
pumps backed by blower  
pumps and rotary gas pumps.

Temperature:

Temperature range:  $-300^{\circ}$  F to  $+2000^{\circ}$  F.

Thermal system: Quartz lamps and nitrogen  
curtain wall.

Cryogenics:

LN<sub>2</sub> panel area: 1600 square feet.

Solar Simulation:

Area illuminated: 7 ft diameter

Maximum intensity: 140 watts/ft<sup>2</sup>.

System type: Carbon arc.

Other Environment Capabilities:

Structural loading, shock and vibration  
provisions.

Systems Contractor:

Design: Bendix Systems Division.

Fabrication: Chicago Bridge and Iron Company.

Operational Date:

Vacuum: November, 1961.

Complete system: January, 1962.



25-FOOT SPACE ENVIRONMENT FACILITY  
JET PROPULSION LABORATORY  
PASADENA, CALIFORNIA

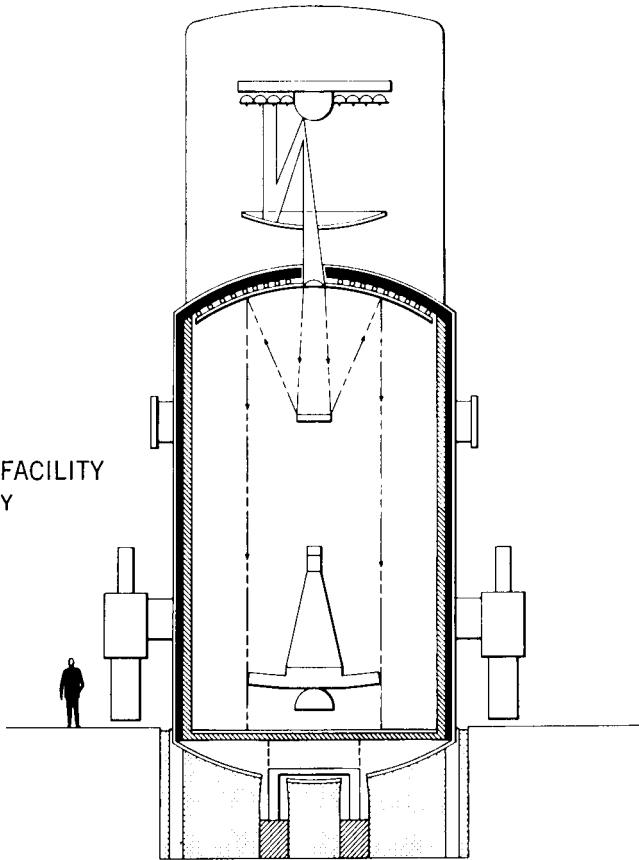

Construction:

Overall dimensions: 27 ft diameter x 80 ft high.

Construction materials:

Shell: 304 Stainless Steel.

Shroud: Aluminum.

Work space dimensions: 25 ft diameter  
x 25 ft high.

Pressure:

Ultimate pressure:  $1 \times 10^{-6}$  mm-Hg.

Time to achieve ultimate pressure: 3-1/4 hours.

Pumping system: Ten 36-inch oil diffusion  
pumps backed by blowers and  
the wind tunnel compressors.

Temperature:

Temperature range:  $-320^{\circ}$  F to ambient  
(possible).

Thermal system: LN<sub>2</sub> panels and solar  
simulation.

Cryogenics:

LN<sub>2</sub> panel area: 4200 square feet.

Solar Simulation:

Area illuminated: 11 ft diameter.

Maximum intensity: 75 watts/ft<sup>2</sup> (or 5 ft  
diameter 130 watts/ft,  
future 15 ft diameter  
275 watts/ft<sup>2</sup>).

System type: Hg-Xe lamps.

Other Environment Capabilities:

Provision is made to use electrodynamic  
shakers in the chamber with force ratings up  
to approximately 30,000 pounds.

Systems Contractor (Prime):

Design: Consolidated Vacuum Corp.

Fabrication: Consolidated Vacuum Corp.

Operational Date:

December, 1962.

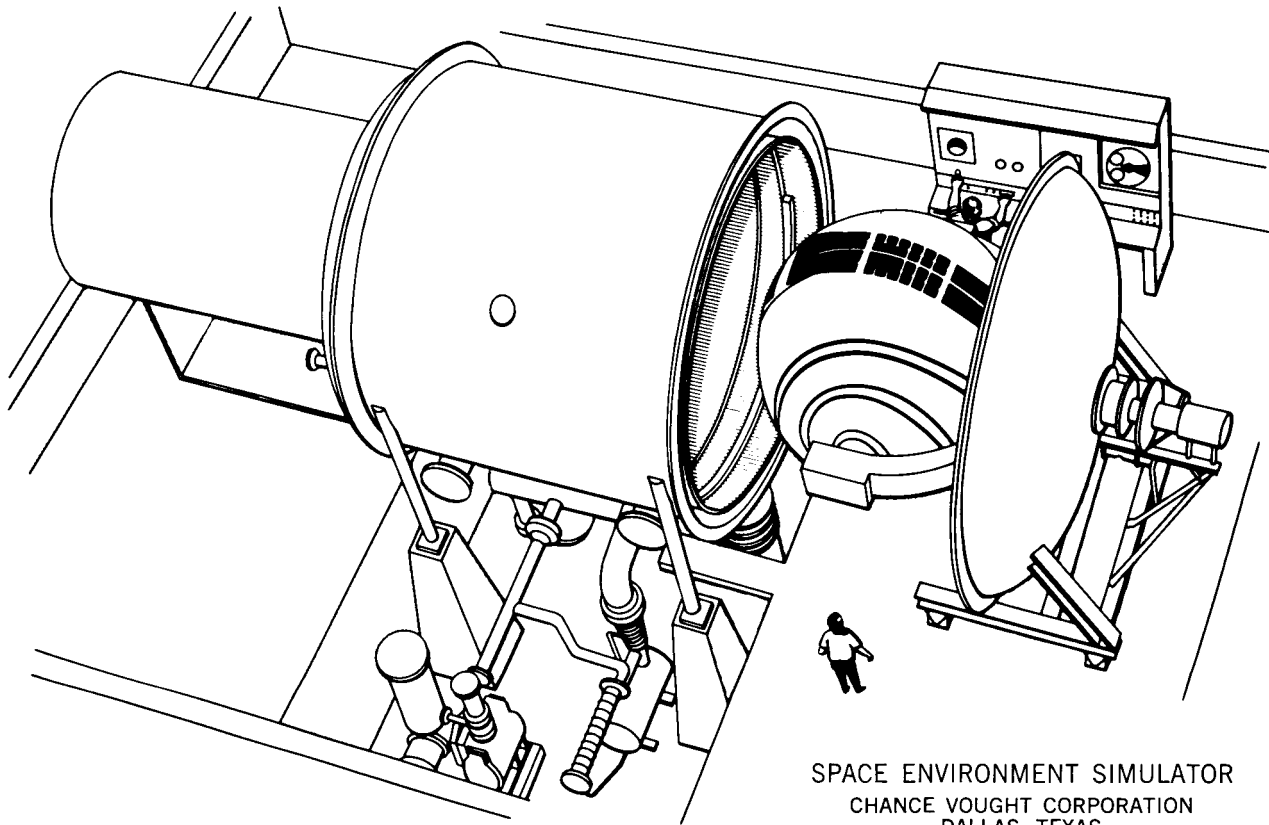

SPACE ENVIRONMENT SIMULATOR  
 CHANCE VOUGHT CORPORATION  
 DALLAS, TEXAS

Construction:

Overall dimensions: 12 ft diameter x 15 ft long.  
 Construction materials:  
 Shell: 304 Stainless Steel.  
 Shroud: Finned aluminum tubing.  
 Work space dimensions: 10 ft diameter x 10 ft.

Pressure:

Ultimate pressure:  $1 \times 10^{-7}$  mm-Hg.  
 Time to achieve ultimate pressure: 2-1/2 hours.  
 Pumping system: Three 32-inch oil diffusion pumps backed by a booster and mechanical pump.

Temperature:

Temperature range:  $-320^{\circ}$  F to ambient.  
 Thermal system:  $LN_2$  heat sink and solar simulation.

Cryogenics:

$LN_2$  panel area: 460 square feet.

Solar Simulation:

Area illuminated: 6 ft diameter.  
 Maximum intensity: 130 watts/ft<sup>2</sup>.  
 System type: Hg-Xe lamps with external elliptical reflectors.

Other Environmental Capabilities:

Two-axis orbital rotation of specimen of 1000-pound maximum weight. Maximum envelope of 8-foot diameter sphere. Slip rings on motion gimbal for power in/data out.

Systems Contractor:

Design: Tenney Engineering, Inc.  
 Fabrication: Tenney Engineering, Inc. (prime).

Operational Date:

December, 1961 (partial operation).

SPACE SIMULATION SYSTEM  
GRUMMAN AIRCRAFT ENGINEERING CORPORATION  
BETHPAGE, LONG ISLAND, NEW YORK

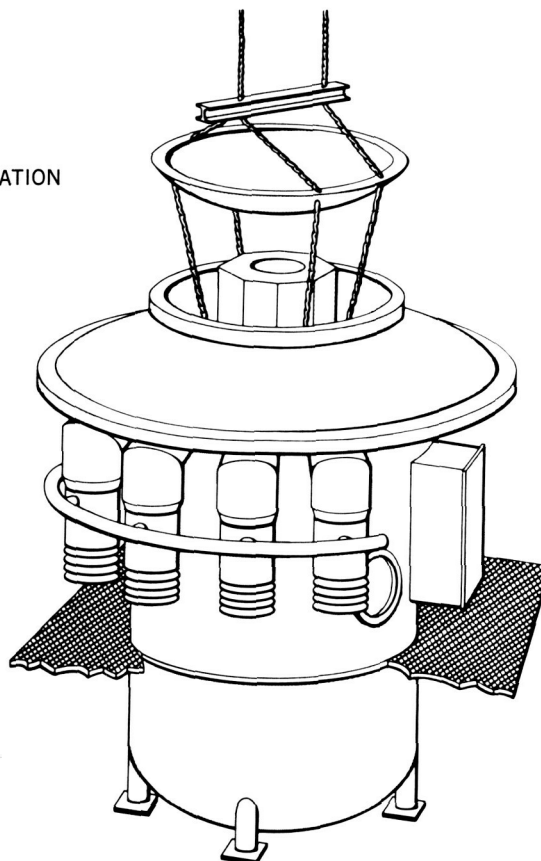

Construction:

Overall dimensions: 19 ft diameter (30 ft at bustle) x 28 ft high.

Construction materials:

Shell: 304 Stainless Steel.

Shroud: Stainless steel.

Work space dimensions: 15 ft diameter x 20 ft high.

Pressure:

Ultimate pressure:  $5 \times 10^{-9}$  mm-Hg with cryo.

Time to achieve ultimate pressure: 6 hours.

Pumping system: Eight 32-inch oil diffusion pumps backed by roughing system.

Temperature:

Temperature range:  $-320^{\circ}$  F to  $+300^{\circ}$  F.

Thermal system: Liquid or gaseous N in shroud.

Cryogenics:

LN<sub>2</sub> panel area: 2200 square feet.

Solar Simulation:

Provisions made for heat flux simulation tailored to specific project.

Other Environment Capabilities of this Chamber:

Backfilling with N<sub>2</sub> gas 1 to 3 tor.

Systems Contractor (Prime):

Design: Chicago Bridge and Iron Co.

Fabrication: Chicago Bridge and Iron Co.

Operational Date:

March 1, 1962.

SPACE ENVIRONMENT SIMULATOR  
 GENERAL ELECTRIC COMPANY  
 VALLEY FORGE, PENNSYLVANIA

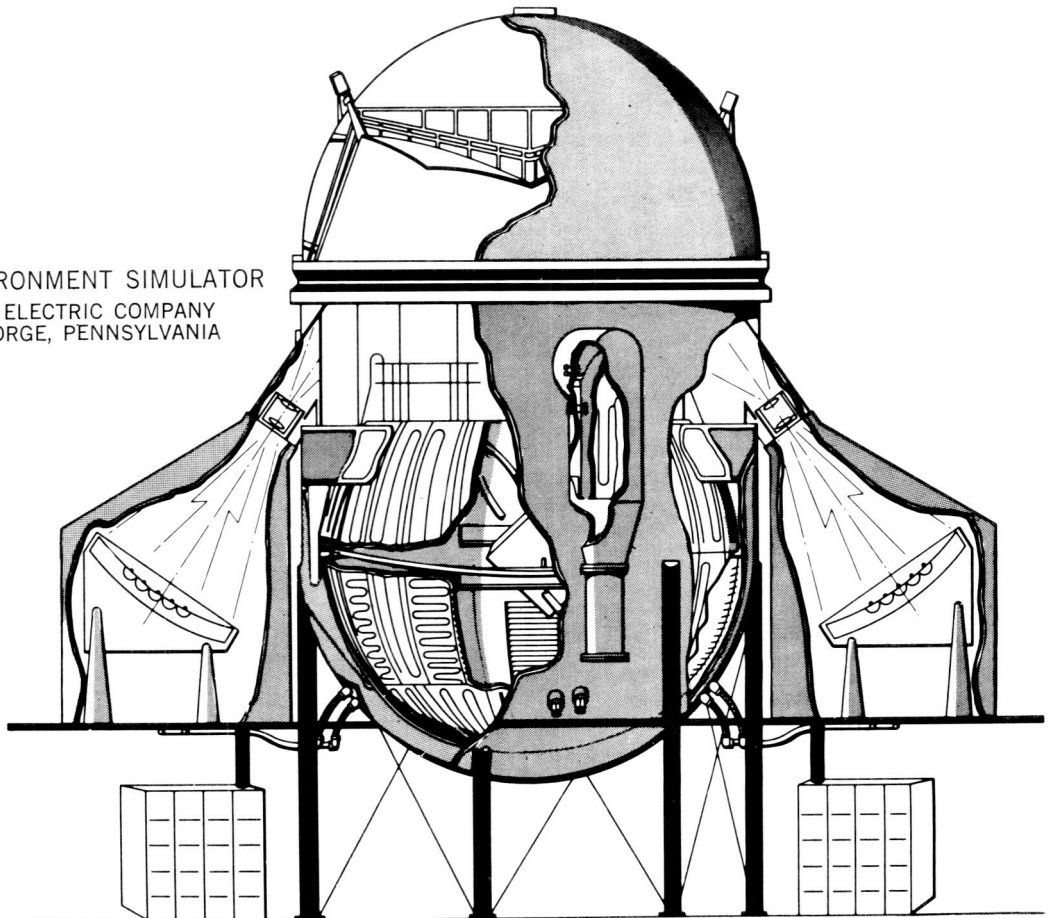

Construction:

Overall dimensions: 32 ft diameter x 54 ft high.  
 Construction materials:  
 Shell: 304 Stainless Steel.  
 Shroud: Aluminum.  
 Work space dimensions: 20-ft diameter sphere.

Pressure:

Ultimate pressure:  $1 \times 10^{-9}$  mm-Hg.  
 Time to achieve ultimate pressure: 6 hours.  
 Pumping system: Cryogenic pumping and two 32-inch oil diffusion pumps backed by booster and mechanical pumps.

Temperature:

Temperature range: Function of experiment design.  
 Thermal system: Solar simulation and 100°K walls.

Cryogenics:

LN panel area: 5400 square feet.  
 He panel area: 725 square feet.

Solar Simulation:

Area illuminated: 20 ft diameter.  
 Maximum intensity: 140 watts/ft<sup>2</sup>.  
 System type: Off axis parabolic collimating reflector with xenon arc-lamp source.

Other Environment Capabilities:

Provision for future addition of vibration facilities.

Systems Contractor:

Design: General Electric Company.  
 Fabrication: General Electric Company (prime).

Operational Date:

March, 1962.  
 November 1962 for Solar.

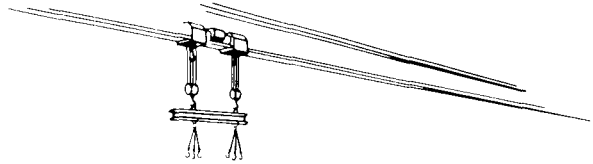

30-FOOT THERMAL-VACUUM AND SPACE  
SIMULATION TEST FACILITY  
SPACE TECHNOLOGY LABORATORIES, INC.  
LOS ANGELES, CALIFORNIA

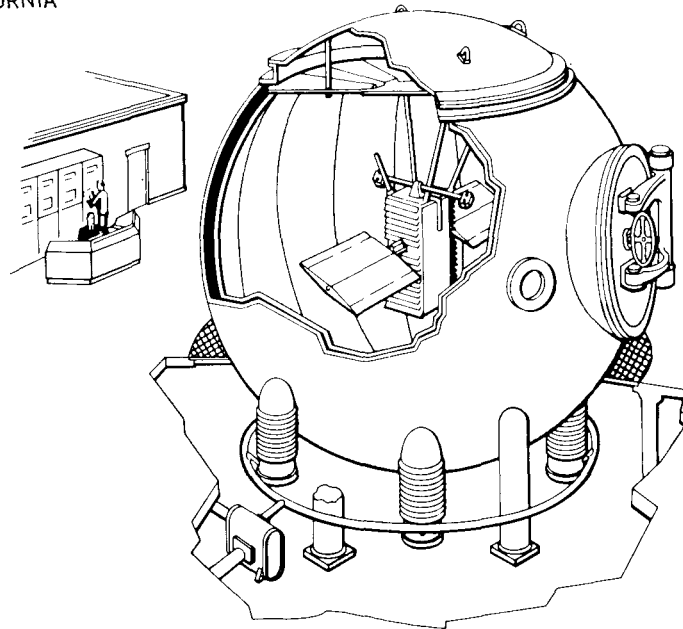

Construction:

Overall dimensions: 30-ft diameter sphere.  
Construction materials:  
Shell: 304 Stainless Steel.  
Shroud: Aluminum.  
Work space dimensions: 28-ft diameter sphere.

Pressure:

Ultimate pressure:  $3 \times 10^{-7}$  mm-Hg.  
Time to achieve ultimate pressure: 12 hours.  
Pumping system: Four 32-inch oil diffusion  
pumps backed by blower and  
mechanical pumps.

Temperature:

Temperature range:  $-320^{\circ}$  F to  $+275^{\circ}$  F.  
Thermal system: Gaseous N within shroud.

Cryogenics:

LN<sub>2</sub> panel area: 2450 square feet.

Solar Simulation:

Area illuminated: 7 ft x 4 ft expandable to  
11 ft x 11 ft.  
Maximum intensity: 260 watts/ft<sup>2</sup>, current  
system 130 watts/ft<sup>2</sup>.  
System type: Carbon arc source.

Systems Contractor:

Design: Chicago Bridge and Iron Co.  
Fabrication: Chicago Bridge and Iron Co.

Operational Date:

November, 1962; with solar January 1, 1963.

MARK I AEROSPACE SIMULATOR  
ARNOLD ENGINEERING DEVELOPMENT STATION  
ARNOLD AIR FORCE STATION, TENNESSEE

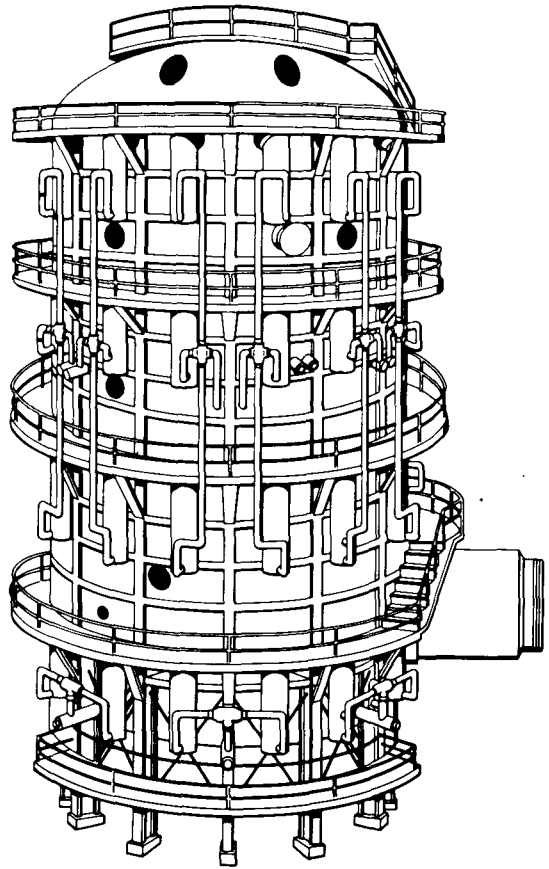

Construction:

Overall dimensions: 42 ft diameter x 82 ft high.  
Construction materials:  
Shell: 304 Stainless Steel.  
Shroud: Copper.  
Work space dimensions: 35 ft diameter x 65 ft.

Pressure:

Ultimate pressure:  $1 \times 10^{-8}$  mm-Hg.  
Time to achieve ultimate pressure: 24 hours.  
Pumping system: Forty-eight 32-inch oil diffusion pumps and a  $20^\circ$  K cryogenic system backed by roughing pumps and wind tunnel facilities.

Temperature:

Thermal system: Solar simulation and LN<sub>2</sub> panels.

Cryogenics:

LN<sub>2</sub> panel area: 13,376 square feet.  
He panel area: 8160 square feet.

Solar Simulation:

Area illuminated: 5 ft x 32 ft.  
Maximum intensity: 130 watts/ft<sup>2</sup>.  
System type: Carbon arc lamps in optical system.

Other Environment Capabilities:

Vibration: Up to 200,000-pound force from 10 to 600 cps.

Up to 5,000-pound force from 600 to 2000 cps.

Ascent simulation: Sea level to 80,000 feet in 90 seconds.

Systems Contractor:

Design: Radio Corporation of America.  
Fabrication: Compudyne Corp.

Operational Date:

August, 1963.

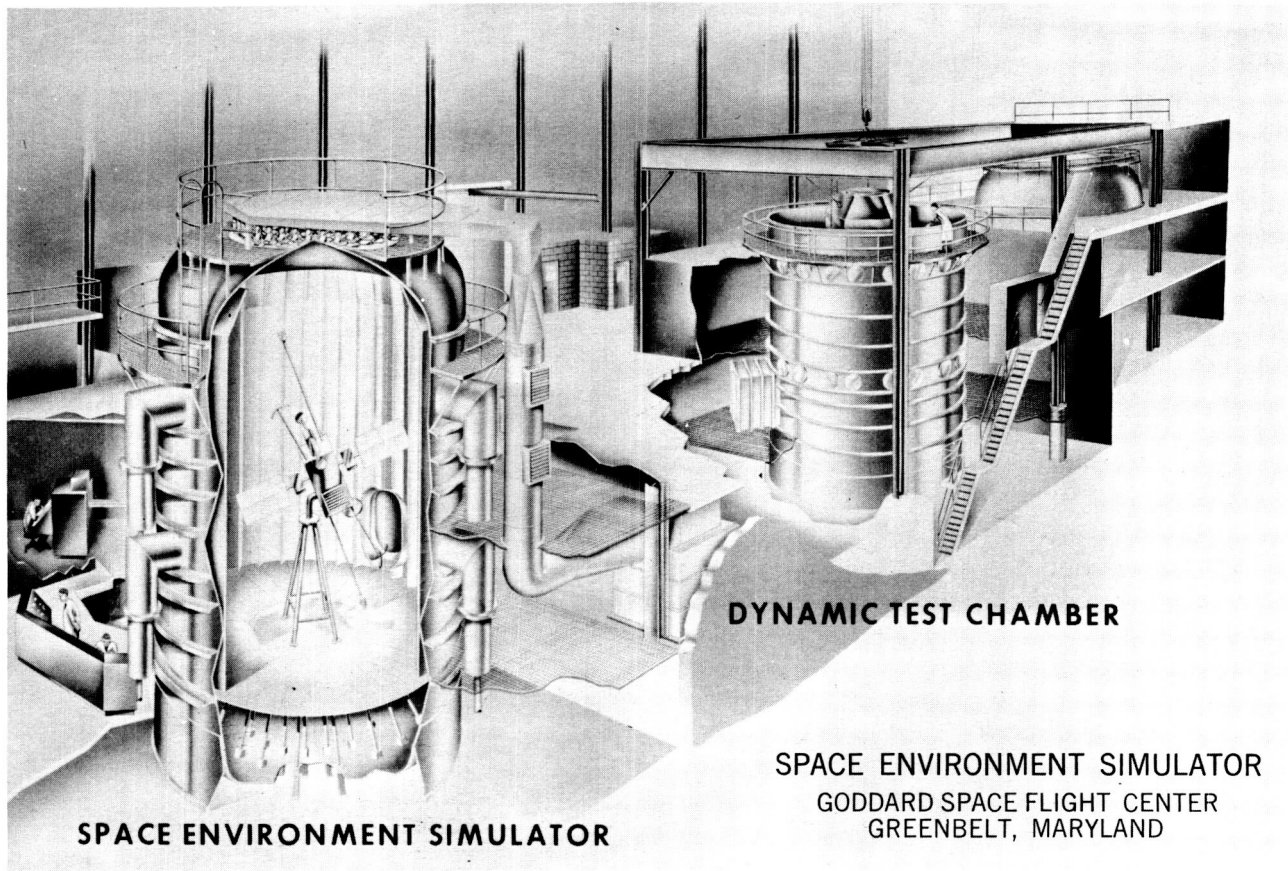

**SPACE ENVIRONMENT SIMULATOR**

**DYNAMIC TEST CHAMBER**

**SPACE ENVIRONMENT SIMULATOR**  
**GODDARD SPACE FLIGHT CENTER**  
**GREENBELT, MARYLAND**

Construction:

Overall dimensions: 35 ft diameter x 60 ft high.  
 Construction materials:  
 Shell: 304 Stainless Steel.  
 Shroud: Aluminum.  
 Work space dimensions: 28 ft diameter x 40 ft.

Pressure:

Ultimate pressure:  $2 \times 10^{-9}$  mm-Hg.  
 Time to achieve ultimate pressure: 24 hours.  
 Pumping system: Cryogenic and seventeen 32-inch oil diffusion pumps backed by mechanical booster pumps.

Temperature:

Temperature range:  $-320^{\circ}\text{F}$  to  $+215^{\circ}\text{F}$ .  
 Thermal system: Liquid and gaseous N.

Cryogenics:

LN<sub>2</sub> panel area: 8000 square feet.  
 He panel area: 2000 square feet.

Solar Simulation:

Area illuminated: 20 ft diameter.  
 Maximum intensity: 275 watts/ft<sup>2</sup>.  
 System type: Multimodular, He-Xe lamps.

Systems Contractor:

Design: Minneapolis-Honeywell Regulator Company (Prime).  
 F. J. Stokes Corp. - Vacuum and Cryogenics.

Fabrication: Minneapolis-Honeywell Regulator Company (Prime).  
 F. J. Stokes Corp. - Vacuum and Cryogenics.

Operational Date:

December, 1962.  
 Solar Simulation - early 1963.