

NASA TECHNICAL NOTE

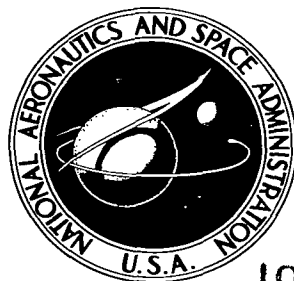

NASA TN D-2499

12

NASA TN D-2499

LOAN COPY: RETU
AFWL (WLIL-
KIRTLAND AFB, N



0154703

TECH LIBRARY KAFB, NM

**THE SUSCEPTIBILITY OF SIX STAINLESS
STEELS TO STRESS CORROSION AT
AMBIENT AND ELEVATED TEMPERATURES**

by David N. Braski

Langley Research Center

Langley Station, Hampton, Va.



THE SUSCEPTIBILITY OF
SIX STAINLESS STEELS TO STRESS CORROSION AT
AMBIENT AND ELEVATED TEMPERATURES

By David N. Braski

Langley Research Center
Langley Station, Hampton, Va.

NATIONAL AERONAUTICS AND SPACE ADMINISTRATION

For sale by the Office of Technical Services, Department of Commerce,
Washington, D.C. 20230 -- Price \$0.50

THE SUSCEPTIBILITY OF
SIX STAINLESS STEELS TO STRESS CORROSION AT
AMBIENT AND ELEVATED TEMPERATURES

By David N. Braski
Langley Research Center

SUMMARY

The susceptibility of six stainless steels to stress corrosion has been determined by exposing self-stressed specimens indoors and outdoors at ambient temperatures and also at 550° F (561° K). The salt-coated stainless steels were resistant to stress corrosion cracking at 550° F (561° K) for exposures from 4000 to 10,000 hours. Specimens of AM-350 DA and AM-367 stainless steel were found to be very susceptible to stress-corrosion cracking with exposures less than 5000 hours in both the indoor (with a salt coating) and outdoor (with and without a salt coating) environments, while the AM-350 CRT, AISI 301, PH 15-7 Mo, and PH 14-8 Mo displayed excellent resistance. In general, the stainless steels with higher austenite contents appeared to have better resistance to the corrosive effects of salt, both at room temperature and at 550° F (561° K).

INTRODUCTION

At present there is much concern about the possible problem of stress-corrosion cracking in the titanium alloys and stainless steels being considered for use on a Mach 3 supersonic transport (ref. 1). The skin and other structural members of such an aircraft would be subjected to the following conditions that could produce stress-corrosion cracks: Induced or residual tensile stresses, sea-coast environments, salt treatment of runways, and exposure to temperatures up to 600° F (589° K).

In a recent study at the NASA Langley Research Center the relative susceptibility of four titanium alloys to salt-stress corrosion at 550° F (561° K) was investigated (ref. 2). The purpose of the present investigation is to determine the effects of stress corrosion on six stainless steels at room temperature and at 550° F (561° K), as well as in outdoor environments. A metallurgical study is also included which consists of microstructural examinations, crack-penetration measurements, and determinations of retained austenite made by X-ray diffraction techniques.

MATERIALS AND SPECIMEN

Specimens were taken from the following stainless-steel sheet materials: AM-350 cold-rolled and tempered (CRT), AM-350 double aged (DA), AISI 301, PH 15-7 Mo, all 0.025 inch (0.064 cm) thick; PH 14-8 Mo, and AM-367, 0.050 inch (0.127 cm) thick. The chemical composition, heat treatment, and room-temperature tensile properties for each are listed in tables I, II, and III, respectively.

Self-stressed specimens, similar to those used in reference 2, were constructed from sheet material as shown in figure 1. The specimens were fabricated in both longitudinal and transverse grain directions to provide a maximum fiber stress of 100 ksi (690 MN/m^2) as follows:

- (1) Cut and machine 4 by 1/4 inch (10.16 by 0.64 cm) strips (fig. 1(a)).
- (2) Heat treat if applicable. (See table II.)
- (3) Bend ends of each strip to proper bend angle (approximately 25° for 0.025 inch (0.064 cm) and 12° for 0.050 inch (0.127 cm) material). (See fig. 1(b).)
- (4) Clean the strips chemically. (See appendix.)

(5) Place two cleaned strips together, clamp the ends and spot-weld (fig. 1(c)). All specimens were handled carefully with clean white gloves throughout this operation to prevent any contamination.

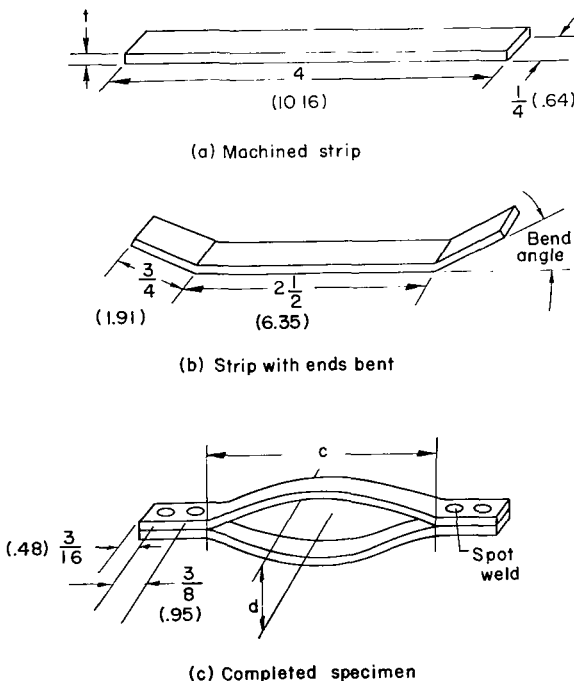

Figure 1.- Construction of self-stressed specimen. Dimensions are given in inches and parenthetically in centimeters.

The magnitude of the inner and outer fiber stresses in each strip depends upon the radius of curvature, the thickness, and Young's modulus for the material at the exposure temperature. As long as elastic conditions prevail, the distance d (fig. 1(c)) between the inner faces of the strips can be determined for a given maximum fiber stress from the following geometric, stress-strain relationship:

$$d = 2R - \sqrt{4R^2 - C^2}$$

where

R radius of curvature of curved portion of each strip, $tE/2\sigma$, in. (m)

C chord length or distance between bent-up ends, in. (m)

TABLE I.- CHEMICAL ANALYSIS OF THE STAINLESS STEELS

[Weight percentages supplied by producers]

Alloy	Weight, percent											
	C	Mn	P	S	Si	Cr	Ni	Co	No	Ti	Al	Fe
AM-350	0.080	0.76	0.019	0.012	0.30	16.80	4.15	-----	2.80	----	----	Bal
AISI 301	.089	.154	.023	.017	.47	17.30	7.70	0.05	.16	----	----	Bal
PH 15-7 Mo	.063	.55	.020	.011	.44	14.96	7.23	-----	2.15	----	1.14	Bal
PH 14-8 Mo	.040	.28	.008	.003	.67	14.38	8.14	-----	2.00	----	1.22	Bal
AM-367	.021	.024	.002	.009	.08	14.25	3.40	15.47	1.99	0.35	.03	Bal

TABLE II.- HEAT TREATMENT OF THE STAINLESS STEELS

Alloy	Condition	Heat treatment
AM-350	CRT	Cold rolled 20 percent; tempered 3 to 5 min at 930° F (772° K); air cool
AM-350	DA	Anneal at 1850° to 1975° F (1283° to 1353° K), air cool; reheat at 1375° F (1019° K) for 3 hr, air cool; age 3 hr at 850° F (728° K), air cool
AISI 301	56 % CR	Anneal at 2000° F (1366° K), air cool; cold reduced 56 percent
PH 15-7 Mo	TH 1050	Anneal at 1950° F (1339° K), air cool; reheat at 1400° F (1033° K) for 1/2 hr, quench to 60° (289° K); age 1½ hr at 1050° F (838° K) air cool
PH 14-8 Mo	SRH 950	Anneal at 1825° F (1270° K), air cool; reheat at 1700° F (1200° K) for 1 hr, quench to -100° F (200° K), and hold for 8 hr; age 1 hr at 950° F (783° K), air cool
AM-367	Maraging	Anneal at 1400° F (1033° K); quench to -100° F (200° K), and hold for 16 hr; age 8 hr at 850° F (728° K), air cool

TABLE III.- ROOM-TEMPERATURE TENSILE PROPERTIES OF THE STAINLESS STEELS

Alloy	Condition	Thickness		Yield strength				Tensile strength				Elongation, % in 2-in. length	
				Longitudinal		Transverse		Longitudinal		Transverse		Longitudinal	Transverse
		in.	cm	ksi	MN/m ²	ksi	MN/m ²	ksi	MN/m ²	ksi	MN/m ²		
AM-350	CRT	0.025	0.064	181.0	1248	168.0	1158	205.0	1413	208.3	1436	18.5	17.5
AM-350	DA	.025	.064	152.5	1051	158.0	1089	185.7	1280	188.0	1296	14.5	12.7
AISI 301	56 % CR	.025	.064	189.5	1306	181.7	1253	209.0	1441	216.0	1489	5.5	6.0
PH 15-7 Mo	TH 1050	.025	.064	211.4	1457	216.4	1492	215.0	1482	221.2	1525	5.0	4.7
PH 14-8 Mo	SRH 950	.050	.127	183.0	1262	183.5	1265	225.0	1551	227.0	1565	12.2	9.5
AM-367	Maraging	.050	.127	242.0	1668	-----	-----	243.4	1678	-----	-----	4.2	----

t strip thickness, in. (m)
E Young's modulus, ksi (MN/m²)
σ tensile or compressive stress, ksi (MN/m²)

The units used herein for physical quantities are given in the U.S. Customary System and parenthetically in the International System (abbreviated as SI). Resolution 12 of the Eleventh General Conference on Weights and Measures (ref. 3) established the SI as a practical system of measurements for international use. Conversion factors relating these units in the two systems are:

Length: Inches × 0.0254 = Meters (m)

Force: Pounds × 4.448 = Newtons (N)

Stress: ksi × 6.894 = Meganewton/square meter (MN/m²)

Temperature: $\frac{5}{9}({}^{\circ}\text{F} + 459.67) = {}^{\circ}\text{K}$

PROCEDURE

Salt Coating

The corroding agent, pure sodium chloride, was applied to the specimens by dipping them into a boiling, supersaturated salt solution, after which they were dried in an oven at 250° F (394° K). This procedure was repeated as many times as needed to produce a uniform salt coating of 0.004 inch to 0.006 inch (0.010 to 0.015 cm) over the surface of the specimen. The ends of the specimens were cleaned to prevent corrosion from developing at or near the spot welds.

Exposure

The specimens were exposed to the following environments:

(1) Exposure at 550° F (561° K): Salt-coated and uncoated specimens were placed in individual electric ovens for exposure times up to 10,000 hours.

(2) Exposure at ambient temperatures:

(a) Indoor exposure: Salt-coated specimens were exposed at the ambient room temperature indoors for times up to 2500 hours.

(b) Outdoor exposure: Uncoated specimens were exposed outdoors at ambient temperatures for times up to 10,000 hours at the Langley Research Center which is located near the mouth of the Chesapeake Bay.

(c) Outdoor exposure with salt dipping: Uncoated specimens were exposed outdoors and dipped twice a week in a cold saturated salt solution. Exposure times ran up to 2500 hours. The accumulation of salt on these specimens was slight.

(3) Exposure at 550° F (561° K) combined with indoor exposure: Salt-coated specimens were exposed for various times at 550° F (561° K) with subsequent indoor exposure at room temperature. Total exposure times were from 6000 to 9000 hours.

Only a limited number of specimens were available for environments 2(a), 2(c), and 3 because the original program was designed to evaluate environments 1 and 2(b).

Compression Tests

After exposure, the salt coatings were removed with a water rinse, and the specimens were tested under compression at room temperature. The compression-test apparatus and clamping fixtures are shown in figure 2. Two clamping fixtures were used to support the specimen vertically in the hydraulic testing machine. A load of 200 pounds (890 N) per minute was applied and recorded automatically against the head displacement. The head displacement, which is equivalent to specimen shortening, was measured by a deflectometer consisting of an aluminum-alloy cantilever beam instrumented with strain gages at the base of the beam.

Metallurgical Study

Metallographic examinations.- A metallographic examination of the specimens was necessary to determine whether the degradation of the material was caused by general corrosion, pitting, stress-corrosion cracking, or metallurgical changes. Metallographic samples were cut from the curved portions of the untested specimens and from sections of the tested specimens that were remote from the fracture zone where severe bending had a tendency to open cracks. The samples were edge mounted, polished, and etched with a solution containing 4 grams of cupric sulphate, 20 milliliters of concentrated hydrochloric acid, and 30 milliliters of water. The various samples were examined, and photomicrographs of representative pits and stress-corrosion cracks were made in a research metallograph.

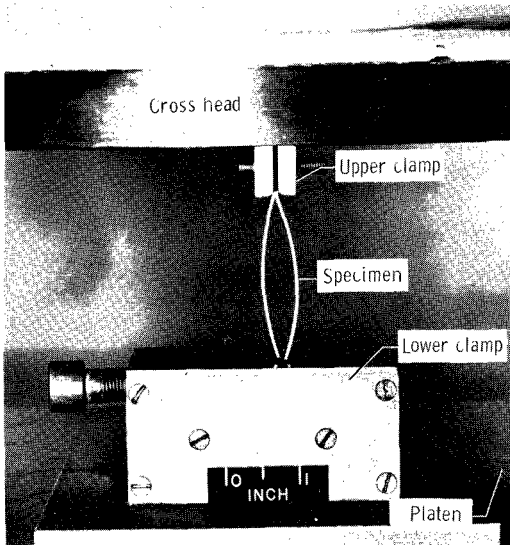

L-64-8301
Figure 2.- Clamping fixtures and
compression-test apparatus.

Penetration of cracks into the base material was measured with a microscope and micrometer eyepiece.

Determination of retained austenite.- The amount of retained austenite in PH 15-7 Mo, PH 14-8 Mo, AM-350 CRT, and AM-350 DA was determined to see whether this factor could be correlated to the susceptibility of a material to stress-corrosion cracking. The "two peak" method described in reference 4 was used, which utilizes the (200) martensite peak and (220) austenite peak as determined by an X-ray diffractometer. Chromium $K\alpha$ radiation with a power setting of 45 kilovolts and 15 milliamperes is used with a 3° beam slit, medium-resolution collimator, 0.2° detection slit, and a vanadium filter. Coupons 1 inch (2.54 cm) square of each sheet material were examined on one face which was hand polished through 600-grit paper. The following formula was used to determine the approximate percentage of retained austenite:

$$\text{Percent} = \frac{100}{1 + \frac{A_{200}}{A_{220}} K}$$

where A_{200} is the area under (200) martensite peak and A_{220} , the area under (220) austenite peak. The constant $K = 2.5$ is based on information supplied by G. K. Clark of the Allegheny Ludlum Steel Corporation.

RESULTS AND DISCUSSION

Typical specimen configurations before and after compression testing are illustrated in figure 3. Unexposed specimens of most materials as well as exposed specimens showing good resistance to stress-corrosion cracking and pitting could be compressed as shown in figure 3(b). Several materials exhibited a somewhat lower bend ductility in the transverse grain specimens. Specimens that were vulnerable to stress-corrosion cracking or other types of corrosion suffered losses in bend ductility and fractured after relatively small amounts of shortening (fig. 3(c)). Apparent metallurgical changes in one alloy after long exposure at an elevated temperature also caused reductions in bend ductility.

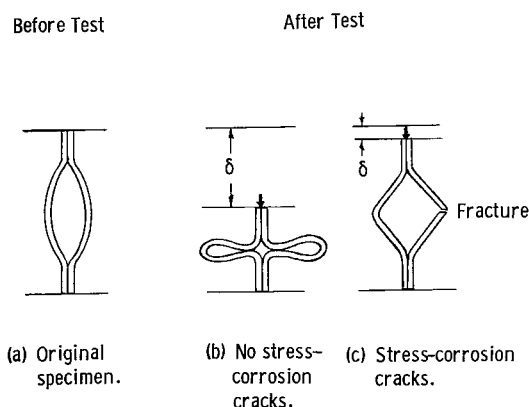

Figure 3.- Effect of stress-corrosion cracks on configuration of specimens tested in compression.

In reference 2 a direct correlation was shown to exist between the shortening at which fracture occurred and the maximum crack penetration in titanium specimens. In the present investigation, a similar correlation was made for AM-350 DA. However, the scatter of pit-penetration values in several stainless steels discouraged any direct correlation of shortening with pit penetration.

The results of the compression tests for the stainless-steel specimens after exposure are shown in figures 4, 5, and 6. The values of shortening at fracture are plotted against exposure in the five different environments. Limiting curves are drawn through the data to represent the most severe corrosion damage that occurred. Figure 4 shows the results of tests on specimens exposed at 550° F (561° K). Figure 5 illustrates the effects of exposure, indoors and outdoors, at ambient temperatures (figs. 5(a), (b), and (c)) and exposure outdoors with periodic salt-water dips (fig. 5(d)). Figure 6 shows the effects of a combined exposure at 550° F (561° K) and exposure indoors. In figure 6 the axis representing exposure time employs two scales; as the exposure at 550° F (561° K) increases, exposure at room temperature decreases so as to maintain a constant exposure time for each material.

Stress-Corrosion Cracking

At 550° F (561° K).- All six salt-coated stainless steels were resistant to stress-corrosion cracking at 550° F (561° K). This result is demonstrated in figure 4 for AM-350 CRT (fig. 4(a)), AM-350 DA (fig. 4(b)), and PH 14-8 Mo

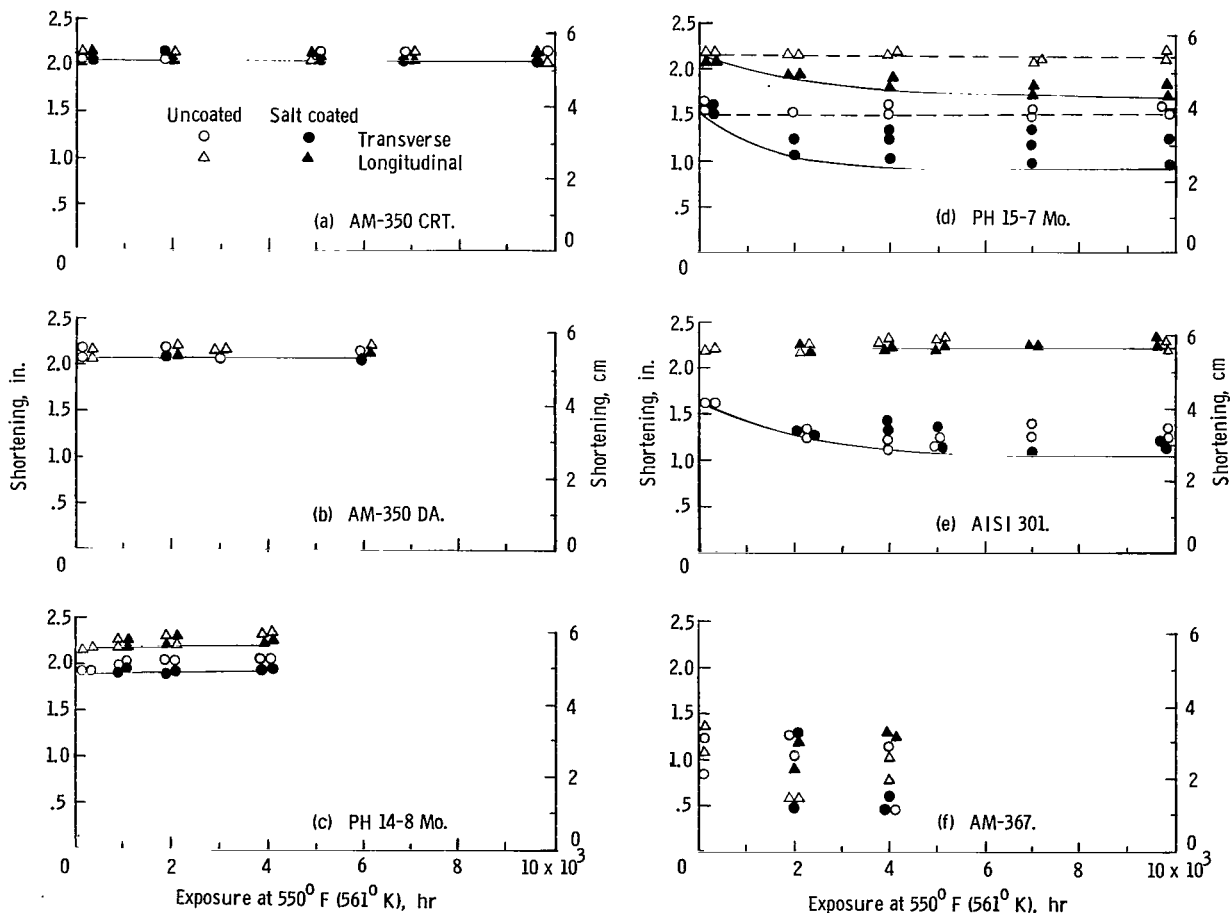

Figure 4.- Results of compression tests on specimens exposed at 550° F (561° K).

(fig. 4(c)) by the straight limiting curves. The PH 15-7 Mo specimens (fig. 4(d)) showed slight losses of bend ductility but no traces of stress-corrosion cracking. The losses were caused by pitting which will be discussed subsequently.

The results of tests on longitudinal AISI 301 specimens (fig. 4(e)) indicate there is little difference between the bend ductilities of salt-coated and uncoated specimens with exposures up to 10,000 hours. The transverse specimens, however, showed a noticeable loss of bend ductility within 3000 hours exposure. Since uncoated specimens as well as coated ones showed these losses, it is unlikely that corrosion in any form is a factor. In a recent investigation of AISI 301 (ref. 5) electron microscopy indicated that precipitation of very fine particles occurs after aging at 850° F (728° K). Moreover, electron micrographs of AISI 301, cold reduced 67 percent and aged at 650° F (616° K) and 750° F (672° K), suggested incipient precipitation within the microstructure. Unpublished NASA data on foil-gage AISI 301 sheet obtained at the Langley Research Center showed marked losses in elongation during tensile tests at 400° F to 800° F (478° to 700° K). Other unpublished NASA room-temperature tensile data on AISI 301 showed 50 percent losses in elongation after prolonged exposure at 550° F (561° K). These results suggest that some metallurgical change occurs in AISI 301 at 550° F (561° K). However, no logical explanation can be given concerning why the losses of bend ductility should be limited to the transverse specimens in this study.

Although no stress-corrosion cracks were detected visually in any of the AM-367 specimens exposed at 550° F (561° K), the data in figure 4(f) demonstrated a large amount of scatter, and no definite limiting curves could be drawn. This scatter may be due in part to the instability of the material, which was part of one of the first experimental heats produced.

At ambient temperatures.- In the indoor and outdoor exposures at ambient temperatures, AM-350 DA (fig. 5) and AM-367 were the only materials susceptible to stress-corrosion cracking. The outdoor exposure with a periodic salt-water dip caused the greatest damage to the AM-350 DA specimens with one specimen failing completely after 576 hours exposure (fig. 5(d)). Exposure indoors with salt caused somewhat less damage (fig. 5(a)), while exposure outdoors without salt produced even less damage (fig. 5(b)).

A limited number of AM-367 specimens were tested indoors and outdoors. Two transverse specimens failed completely within 6500 hours of indoor exposure, while two longitudinal specimens displayed reduced shortening values of 0.16 and 0.42 inch (0.41 and 1.07 cm). One transverse and one longitudinal specimen of AM-367 failed after 2760 hours and 4248 hours of outdoor exposure, respectively. Stress-corrosion cracks were observed on both specimens after approximately 1000 hours.

On the basis of the limited number of tests, on AM-350 DA and AM-367, it appeared that the greater the amount of moisture at ambient temperatures, the greater the damage due to stress-corrosion cracking.

Combined exposure.- Of the three materials (AM-350 DA, AM-350 CRT, and AISI 301) exposed at 550° F (561° K) with subsequent exposure at room

temperature, the AM-350 DA was the only one that developed stress-corrosion cracks. Figure 6(a) shows that two transverse AM-350 DA specimens failed completely after exposure for 5000 hours at 550° F (561° K) followed by 1000 hours at room temperature. Since the AM-350 DA showed good resistance at 550° F (561° K), it seems reasonable to assume that stress-corrosion cracking occurred during the exposure at room temperature. However, it appeared that exposure at 550° F (561° K) accelerated the subsequent stress-corrosion process at room temperature as shown by the limiting curve for the combined exposure (fig. 6(a)). This curve shows much greater stress-corrosion damage than the curve for specimens which were exposed indoors only (fig. 5(a)).

Pitting

At 550° F (561° K).- All stainless steels except PH 15-7 Mo were resistant to pitting with salt at 550° F (561° K). All salt-coated PH 15-7 Mo

Longitudinal	Transverse		
□	△	AM-350 CRT	■ Salt coated
△	□	AM-350 DA	□ Uncoated
◇	○	AISI 301	■ Dipped in salt solution
◇	△	PH 15-7 Mo	⊠ Failed during exposure
△	◇	PH 14-8 Mo	

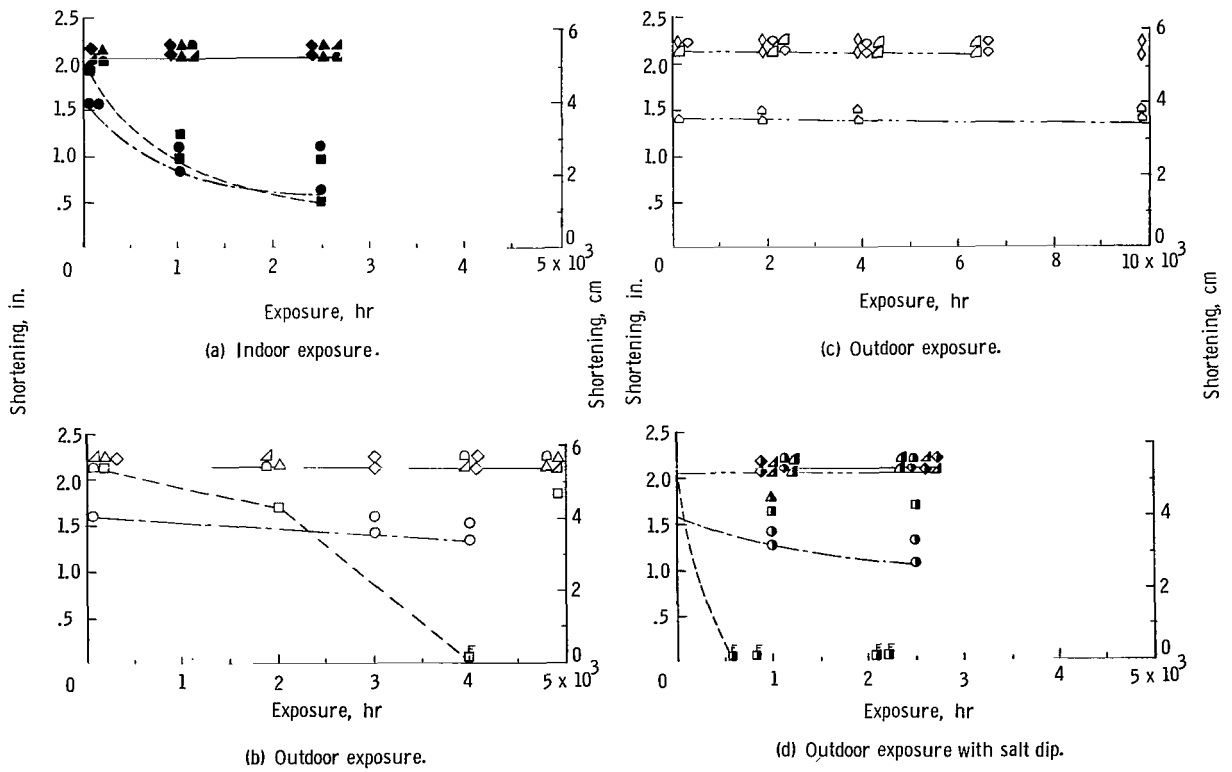

Figure 5.- Results of compression tests on specimens exposed at ambient temperatures; indoors and outdoors.

specimens displayed reduced shortening values due to pitting. The transverse specimens showed a slightly greater susceptibility to pitting than the longitudinal ones. (See fig. 4(d).)

At ambient temperatures.- Alloy AISI 301 was susceptible to pitting in the tests at ambient temperatures (figs. 5(a), (b), and (d)). Again, losses in bend ductility due to pitting were restricted to the transverse specimens. The longitudinal specimens appeared to have as much pitting corrosion as the transverse ones but suffered no losses of bend ductility. Consequently, the limiting curves for AISI 301 are based on the transverse specimens. The salt-coated AISI 301 exposed indoors demonstrated the greatest tendency for pitting (fig. 5(a))

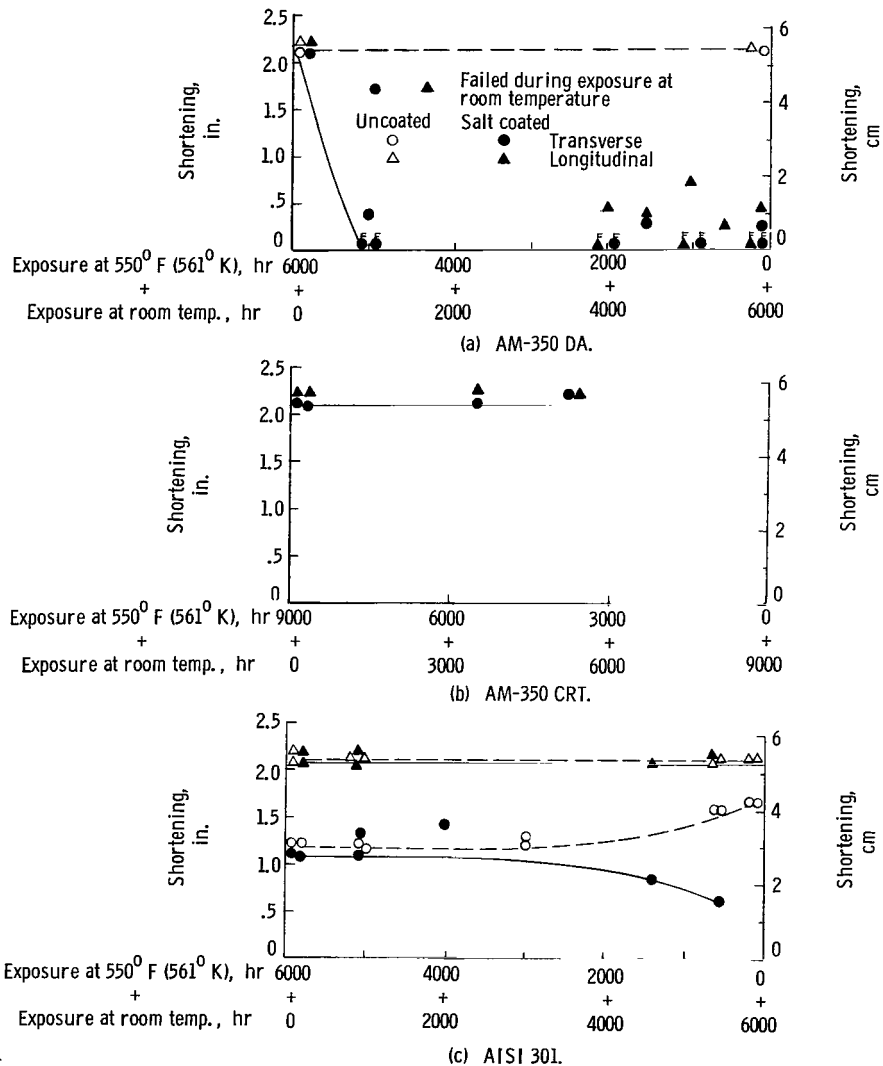

Figure 6.- Results of compression tests on specimens exposed first at 550° F (561° K) and then at ambient indoor temperatures.

whereas those exposed outdoors with periodic salt dips were somewhat less pitted (fig. 5(d)). The uncoated AISI 301 exposed outdoors showed the least amount of pitting (fig. 5(b)).

Several salt-coated PH 15-7 Mo specimens exposed to the indoor environment and several uncoated specimens exposed outdoors with a salt dip displayed shortening values similar to coated PH 15-7 Mo specimens with an equivalent exposure at 550° F (561° K). The uncoated PH 15-7 Mo specimens exposed outdoors (fig. 5(c)) were quite resistant to pitting, even after 10,000 hours exposure.

The results indicate that the greater the amount of salt present in the corroding environment, the greater the pitting damage in AISI 301 and PH 15-7 Mo. Slight to moderate pitting was noted in both the AM-350 DA and AM-367 specimens exposed indoors and outdoors, but the effect on bend ductility was completely overshadowed by the effects of stress-corrosion cracking.

Combined exposure.- Figure 6(c) shows the effect of exposure at 550° F (561° K) followed by exposure at room temperature on salt-coated AISI 301 specimens. Again the only changes in shortening at the fracture point or bend ductility occurred in the transverse specimens. Note that with longer exposures at 550° F (561° K), both salt-coated and uncoated transverse specimens demonstrated reduced shortening; whereas with longer exposures at room temperature only the salt-coated specimens demonstrated reduced shortening. Metallographic examination of these latter specimens attributed the shortening reductions to pitting. It appears, therefore, that two separate processes occurred which lowered the bend ductility of the transverse AISI 301 specimens: the metallurgical changes, which were dependent on elevated temperature exposures; and pitting, which depended on exposure at room temperature.

Metallurgical Study

The following paragraphs discuss the microstructure of each material and its possible relation to the resistance of the material to stress-corrosion cracking. Photomicrographs of typical stress-corrosion cracks are also presented. Table IV gives the results of the X-ray diffraction determinations of retained austenite in AM-350 CRT, AM-350 DA, PH 15-7 Mo, and PH 14-8 Mo.

AM-350 CRT.- The microstructure of AM-350 CRT consists of delta-ferrite stringers in a matrix of martensite with approximately 79 percent retained austenite. The high percentage of retained austenite content in AM-350 CRT probably accounts for its good resistance to pitting. Reference 6, on page 272, states that ferritic and

TABLE IV.- X-RAY DIFFRACTION DATA

Alloy	Peak	2θ, deg	Area, units ²	$\frac{A_{200}}{A_{220}}$	Retained austenite, percent
AM-350 CRT	Mart (200)	105.06	156	0.104	79
	Aust (220)	128.24	1504		
AM-350 DA	Mart (200)	105.42	309	4.12	9
	Aust (220)	128.40	75		
PH 15-7 Mo	Mart (200)	105.39	606	5.46	7
	Aust (220)	128.20	112		
PH 14-8 Mo	Mart (200)	105.38	676	.964	29
	Aust (220)	128.22	701		

martensitic steels have a greater tendency toward pitting than austenitic steels. The high austenite content of AM-350 CRT could also account, at least partly, for its excellent resistance to salt-stress corrosion at 550° F (561° K).

AM-350 DA.- Figure 7 shows an edge view of a stress-corrosion crack in a longitudinal specimen of AM-350 DA exposed 6000 hours at room temperature. The crack penetrates through more than half the thickness of the 0.025-inch (0.064-cm) sheet.

Figure 8 shows the results of representative crack-penetration measurements as a function of combined exposure at 550° F (561° K) and room temperature. It is seen that there is a wide range of crack penetrations at any one exposure. A limiting curve is drawn to represent the maximum crack penetration or maximum damage due to the stress-corrosion cracks. This curve gives a good correlation with the results of the compression tests shown in figure 6(a). Note that several cracks penetrated to a depth approaching the thickness of the sheet which would account for many of the failures of the AM-350 DA specimens during exposure.

Figure 9 illustrates the intergranular nature of stress-corrosion cracking in an AM-350 DA longitudinal specimen exposed for 500 hours at 550° F (561° K) followed by 5500 hours at room temperature. The microstructure of AM-350 DA consists of delta-ferrite pools in a martensite plus 9 percent retained austenite matrix. A network of carbide precipitates lies in the grain boundaries. These carbide precipitates are mainly chromium carbides which deplete the regions directly adjacent to the grain

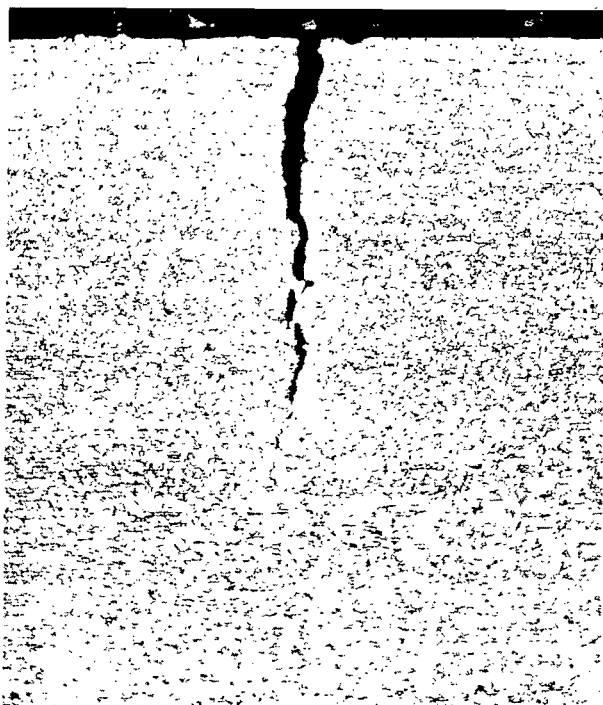

L-64-8302
Figure 7.- Edge view of stress-corrosion crack in AM-350 DA longitudinal specimen exposed 6000 hours at room temperature. 150X.

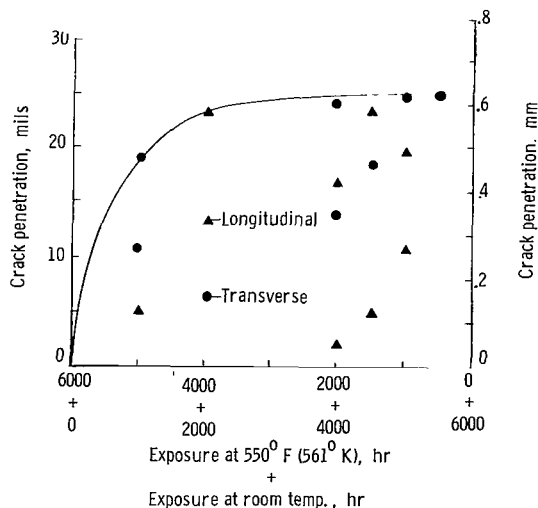
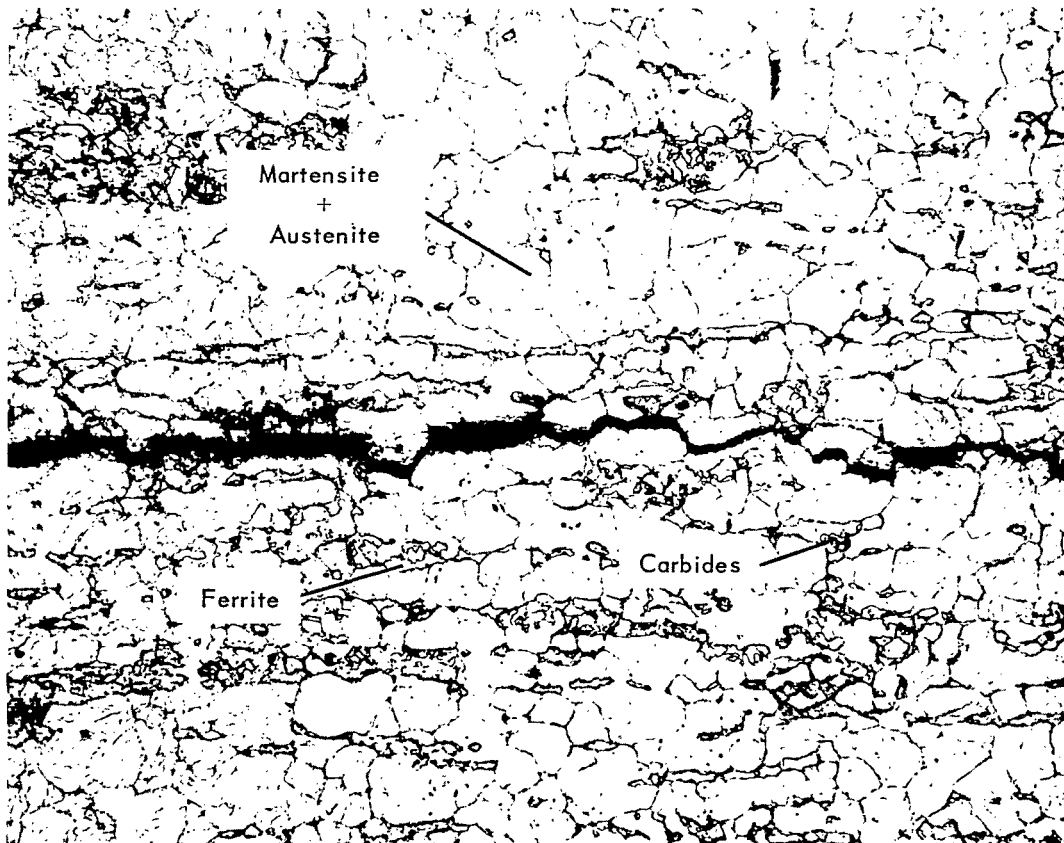

Figure 8.- Crack-penetration values in longitudinal and transverse AM-350 DA specimens plotted as a function of combined exposure at 550° F (561° K) and at ambient indoor temperatures.

boundaries of chromium and thereby lower the corrosion resistance of these regions with respect to the grains. This generally accepted theory (ref. 7) would explain the vast difference between the stress-corrosion resistance of AM-350 DA and AM-350 CRT, which contains no precipitates. The fact that AM-350 CRT contains almost nine times more retained austenite than AM-350 DA would also add to its ability to resist corrosion.

AISI 301.- The microstructure of AISI 301 consists of 100 percent austenite, and this material would therefore be expected to display good resistance to salt pitting. However, the compression tests and metallographic examinations showed that this material was susceptible to pitting. The residual stresses which remained as a result of the severe cold reduction (56 percent) and the 100 ksi (690 MN/m²) induced by the specimen probably were the factors promoting pitting in AISI 301. Reference 8, on page 171, showed results where severely cold worked 18-8 stainless steel pitted more than annealed 18-8 stainless steel in 4 percent sodium chloride solution. The reason for the sensitivity to a slight amount of pitting in transverse specimens but not in longitudinal specimens is as yet unknown.



L-64-8303

Figure 9.- Top view of stress-corrosion crack in AM-350 DA longitudinal specimen exposed 500 hours at 550° F (561° K) followed by 5500 hours at room temperature. 800x.

PH 15-7 Mo.- Figure 10 is a micrograph of typical pits in PH 15-7 Mo. The pit on the left penetrates approximately 1 mil (0.025 mm) into the material. Figure 11 shows the microstructure of PH 15-7 Mo. The microstructure contains 0.063 percent carbon and ferrite in a martensite plus 7 percent retained austenite matrix. A rather continuous network of carbides lies in the grain boundaries and a moderate number of inclusions were also observed in the microstructure.

PH 14-8 Mo.- The microstructure of PH 14-8 Mo, as shown in figure 12, contains only 0.040 percent carbon and consists of ferrite pools in a martensite plus 29 percent retained austenite matrix. The lack of a carbide network and higher austenite content in PH 14-8 Mo are probably the main reasons why it has better resistance to pitting than PH 15-7 Mo. The fact that PH 14-8 Mo has fewer inclusions than PH 15-7 Mo may also add to its corrosion resistance.

AM-367.- Figure 13 shows an edge view of stress-corrosion cracking in the transverse AM-367 specimen which failed after 2760 hours of outdoor exposure. This crack penetrated 20 mils (0.051 cm) into the 25-mil (0.064-cm) sheet. The microstructure of AM-367 consists of small inclusions in a matrix of fine martensite.



L-64-8304

Figure 10.- Pits in PH 15-7 Mo transverse specimen exposed for 7000 hours at 550° F (561° K). 500x.

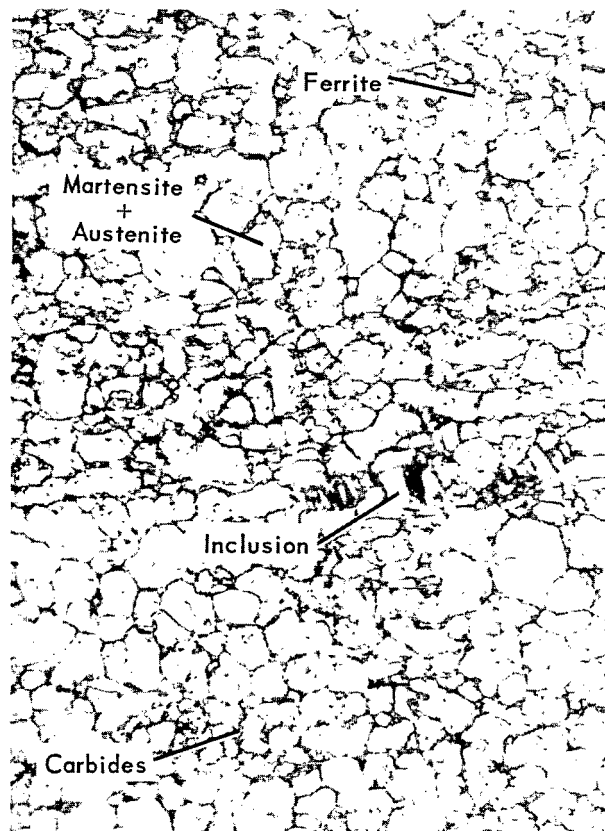

L-64-8305

Figure 11.- Microstructure of PH 15-7 Mo longitudinal specimen with zero exposure. 800x.

Qualitative Ratings of

Stainless Steels

In table V an attempt has been made to give each stainless steel a qualitative rating for each of the five environments based on the results of the compression tests. Each material is rated in respect to its resistance to stress-corrosion cracking and pitting with salt. Several comments can be made concerning these general results. First, AM-350 DA was found to exhibit poor stress-corrosion resistance in all environments involving exposure at ambient temperatures. This result is not surprising since AM-350 DA is known to be quite susceptible to stress-corrosion cracking in seacoast environments. Unlike the AM-350 DA specimen, the AM-350 CRT specimen is seen to display good to excellent resistance to corrosion in all five environments. The AISI 301 specimen showed excellent resistance to stress-corrosion cracking but suffered some pitting corrosion. The

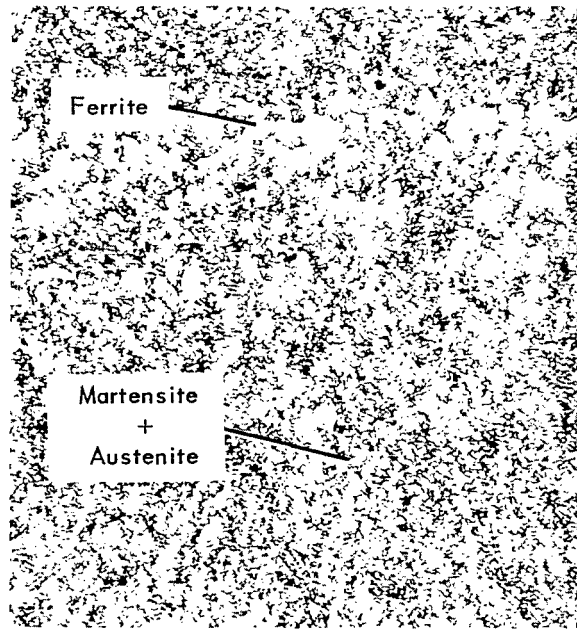

L-64-8306

Figure 12.- Microstructure of PH 14-8 Mo longitudinal specimen with zero exposure. 800x.

TABLE V.- QUALITATIVE RATINGS^a OF THE STAINLESS STEELS

Alloy	Salt-coated specimens						Uncoated specimens		Salt-dipped specimens	
	550° F (561° K)		550° F (561° K) combined with room temperature		Indoor		Outdoor		Outdoor	
	Stress-corrosion cracking	Pitting	Stress-corrosion cracking	Pitting	Stress-corrosion cracking	Pitting	Stress-corrosion cracking	Pitting	Stress-corrosion cracking	Pitting
AM-350 CRT	Excellent	Excellent	Excellent	Excellent	Excellent	Good	Excellent	Excellent	Excellent	Good
AM-350 DA	Excellent	Good	Poor	Fair	Poor	Fair	Poor	Fair	Poor	Fair
AISI 301 56% CR	Excellent	Good	Excellent	Fair	Excellent	Fair	Excellent	Good	Excellent	Fair
PH 15-7 Mo TH 1050	Excellent	Fair	Excellent	Fair	Excellent	Fair	Excellent	Good	Excellent	Fair
PH 14-8 Mo SRH 950	Excellent	Excellent	(b)	(b)	Excellent	Excellent	Excellent	Excellent	Excellent	Excellent
AM-367 maraging	(b)	(b)	(b)	(b)	Poor	Fair	Poor	Fair	(b)	(b)

^aRating evaluation:

Excellent (no evidence of corrosion)

Good (slight corrosion but bend ductility not markedly affected)

Fair (moderate corrosion with the bend ductility substantially reduced)

Poor (severe corrosion with severe losses of bend ductility)

^bNo tests or results inconclusive.

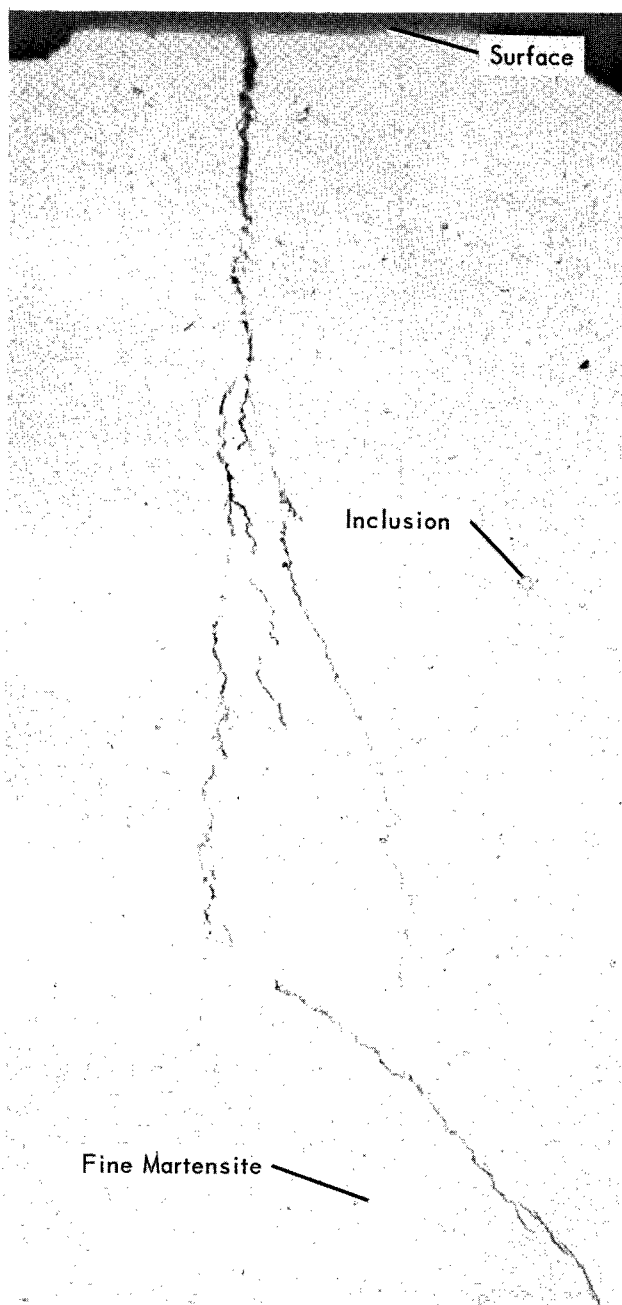

Figure 13.- Edge view of stress-corrosion cracks in AM-367 transverse specimen exposed 2760 hours outdoors. 200x. L-64-8307

PH 15-7 Mo specimen had excellent resistance to stress corrosion but suffered moderate pitting corrosion in almost every environment. This deficiency was apparently corrected in PH 14-8 Mo which demonstrated excellent resistance to both pitting and stress-corrosion cracking. It was difficult to make a fair appraisal of AM-367 because the specimens were taken from one of the first experimental heats produced and only a small number of specimens were tested.

CONCLUDING REMARKS

The results of stress-corrosion tests on salt-coated AM-350 CRT, AM-350 DA, AISI 301, PH 15-7 Mo, PH 14-8 Mo, and AM-367 specimens have shown these stainless steels to be resistant to stress-corrosion cracking at 550° F (561° K) under the test conditions and exposure times used. Specimens of AM-350 DA and AM-367 were very susceptible to stress-corrosion cracking in both indoor and outdoor exposures at ambient temperatures, whereas AM-350 CRT, AISI 301, PH 15-7 Mo, and PH 14-8 Mo displayed excellent resistance to stress corrosion in these environments. Specimens of AISI 301, PH 15-7 Mo, AM-350 DA, and AM-367 showed varying tendencies toward pitting in exposures at 550° F (561° K) and also in those conducted indoors and outdoors at ambient temperatures.

The heat treatment, as demonstrated for AM-350 DA and AM-350 CRT, or the alloy composition, as in PH 14-8 Mo and PH 15-7 Mo, can drastically affect the corrosion resistance of a material to salt. For better corrosion properties in those stainless steels, heat treatments or alloy compositions that cause the precipitation of carbides in the grain boundaries should be avoided. The stainless steels with higher

austenite contents generally appeared to have better resistance to the corrosive effects of salt at room and elevated temperatures. However, the effects of severe cold reduction appeared to promote pitting in the all-austenitic AISI 301.

Langley Research Center,
National Aeronautics and Space Administration,
Langley Station, Hampton, Va., August 24, 1964.

APPENDIX

CLEANING PROCEDURE

The cleaning procedure for the particular stainless steels are as follows:

For AM-350 CRT, AM-350 DA, AISI 301, and AM-367,

- (1) Vapor degrease by means of trichloroethylene.
- (2) Rinse in hot water.
- (3) Immerse in nitric acid, 20 percent by volume, for approximately 5 minutes.
- (4) Wash in hot water and follow with cold rinse.
- (5) Wipe dry with a soft clean cloth.

For PH 15-7 Mo and PH 14-8 Mo,

- (1) Vapor degrease by means of trichloroethylene.
- (2) Rinse in hot water.
- (3) Hand scrub with fiber brush and 1 part acid-base detergent diluted with 20 parts water, by volume.
- (4) Rinse with warm water.
- (5) Dry immediately by use of hand-type hair dryer.

REFERENCES

1. Raring, Richard H.; Freeman, J. W.; Schultz, J. W.; and Voorhees, H. R.: Progress Report of the NASA Special Committee on Materials Research for Supersonic Transports. NASA TN D-1798, 1963.
2. Braski, David N.; and Heimerl, George J.: The Relative Susceptibility of Four Commercial Titanium Alloys to Salt Stress Corrosion at 550° F. NASA TN D-2011, 1963.
3. Anon.: International System of Units, Resolution No. 12. NASA TT F-200, 1964.
4. Ogilvie, Robert E.: Retained Austenite by X-Rays. Norelco Repr., vol. 6, May-June, 1959, pp. 60-61.
5. Banerjee, B. R.; and Hauser, J. J.: Research and Application Engineering to Determine the Effect of Processing Variables on Crack Propagation of High-Strength Steels and Titanium. ASD-TDR-62-1034, Pt. I, U.S. Air Force, Apr. 1963.
6. Uhlig, Herbert H.: Corrosion and Corrosion Control. John Wiley & Sons, Inc., c.1963.
7. Franks, Russell: Chromium-Nickel Austenitic Stainless Steels. The Corrosion Handbook, Herbert H. Uhlig, ed., John Wiley & Sons, Inc., c.1948, pp. 150-165.
8. Uhlig, H. H.: Pitting in Stainless Steels and Other Passive Metals. Herbert H. Uhlig, ed., John Wiley & Sons, Inc., c.1948, pp. 165-173.

2-11/25

"The aeronautical and space activities of the United States shall be conducted so as to contribute . . . to the expansion of human knowledge of phenomena in the atmosphere and space. The Administration shall provide for the widest practicable and appropriate dissemination of information concerning its activities and the results thereof."

—NATIONAL AERONAUTICS AND SPACE ACT OF 1958

NASA SCIENTIFIC AND TECHNICAL PUBLICATIONS

TECHNICAL REPORTS: Scientific and technical information considered important, complete, and a lasting contribution to existing knowledge.

TECHNICAL NOTES: Information less broad in scope but nevertheless of importance as a contribution to existing knowledge.

TECHNICAL MEMORANDUMS: Information receiving limited distribution because of preliminary data, security classification, or other reasons.

CONTRACTOR REPORTS: Technical information generated in connection with a NASA contract or grant and released under NASA auspices.

TECHNICAL TRANSLATIONS: Information published in a foreign language considered to merit NASA distribution in English.

TECHNICAL REPRINTS: Information derived from NASA activities and initially published in the form of journal articles.

SPECIAL PUBLICATIONS: Information derived from or of value to NASA activities but not necessarily reporting the results of individual NASA-programmed scientific efforts. Publications include conference proceedings, monographs, data compilations, handbooks, sourcebooks, and special bibliographies.

Details on the availability of these publications may be obtained from:

SCIENTIFIC AND TECHNICAL INFORMATION DIVISION
NATIONAL AERONAUTICS AND SPACE ADMINISTRATION

Washington, D.C. 20546