

**NASA TECHNICAL NOTE**

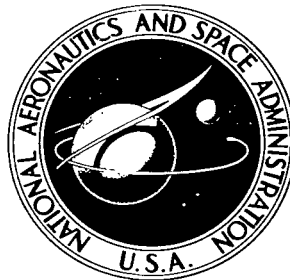

**NASA TN D-3190**

*a.1*

**NASA TN D-3190**

LOAN COPY: RETURN  
AFWL (WLIL-2)  
KIRTLAND AFB, N

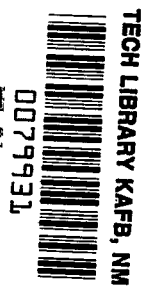

# ROOM-TEMPERATURE TENSILE BEHAVIOR OF $\langle 100 \rangle$ ORIENTED TUNGSTEN SINGLE CRYSTALS WITH RHENIUM IN DILUTE SOLID SOLUTION

*by M. Garfinkle*  
*Lewis Research Center*  
*Cleveland, Ohio*

NATIONAL AERONAUTICS AND SPACE ADMINISTRATION • WASHINGTON, D. C.

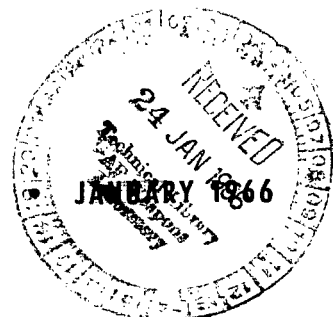



ROOM-TEMPERATURE TENSILE BEHAVIOR OF  
<100>ORIENTED TUNGSTEN SINGLE CRYSTALS WITH  
RHENIUM IN DILUTE SOLID SOLUTION

By M. Garfinkle

Lewis Research Center  
Cleveland, Ohio

NATIONAL AERONAUTICS AND SPACE ADMINISTRATION

---

For sale by the Clearinghouse for Federal Scientific and Technical Information  
Springfield, Virginia 22151 - Price \$1.00

# ROOM-TEMPERATURE TENSILE BEHAVIOR OF $\langle 100 \rangle$ ORIENTED TUNGSTEN SINGLE CRYSTALS WITH RHENIUM IN DILUTE SOLID SOLUTION\*

by M. Garfinkle

Lewis Research Center

## SUMMARY

Tungsten single crystals oriented in the  $\langle 100 \rangle$  direction with rhenium contents from 0 to 9 atomic percent were deformed in tension at room temperature. The addition of rhenium drastically affected the tensile behavior of these crystals. Rhenium additions increased the proportional limit stress and decreased both the flow stress and the rate of work hardening. In addition, discontinuous yielding and necking during deformation were observed in crystals containing 5 atomic percent or more rhenium. Necking was not observed in unalloyed  $\langle 100 \rangle$  oriented crystals. While deformation in the unalloyed  $\langle 100 \rangle$  oriented crystals apparently involved both  $\{110\}$  and  $\{112\}$  slip, crystals with rhenium contents of 5 atomic percent or more deformed primarily by  $\{112\}$  slip. Traces attributable to  $\{110\}$  slip were found only in the work-hardened necked region of the 9 atomic percent rhenium crystals. The tensile behavior of these rhenium-containing crystals was similar to that of  $\langle 110 \rangle$  oriented unalloyed tungsten crystals.

## INTRODUCTION

The hardness of polycrystalline tungsten at room temperature has been observed to be decreased substantially by the addition of approximately 5 atomic percent rhenium (refs. 1 and 2). Observation of this effect has prompted several investigators (refs. 2 to 4) to examine the tensile properties of dilute polycrystalline tungsten-rhenium alloys to determine whether a corresponding increase in ductility occurs. Increased ductility

---

\*The material contained herein was presented as a paper at the Fourth Symposium on Refractory Metals sponsored by the Refractory Metals Committee of the Institute of Metals Division of AIME, French Lick, Indiana, October 4, 1965.

has been observed in both worked and recrystallized material. A maximum in room-temperature ductility occurs at approximately 5 atomic percent rhenium.

The particular manner in which rhenium additions affect the mode of deformation of tungsten has not been well documented. In fact, uncertainties still exist as to the slip systems responsible for deformation in unalloyed tungsten single crystals.

Although it is generally agreed that the slip direction in body-centered-cubic metals is  $\langle 111 \rangle$ , there are various opinions as to the slip planes (refs. 5 and 6). Garlick and Probst (ref. 7) have shown that slip in tungsten occurs on  $\{112\}$  planes in  $\langle 100 \rangle$  oriented single crystals at room temperature, but slip lines were observed only after 10 percent elongation.

The tensile curve for the  $\langle 100 \rangle$  oriented crystals showed no yield point, with plastic flow being evident (shortly after loading) at a very low stress level.

The present study was initiated to determine the effects of rhenium on the room-temperature deformation behavior of  $\langle 100 \rangle$  oriented tungsten single crystals.

TABLE I. - TYPICAL IMPURITY LEVELS IN  
TUNGSTEN SINGLE-CRYSTAL RODS

Element	Amount, ppm	Element	Amount, ppm
Aluminum	<0.01	Molybdenum	2
Beryllium	.001	Nickel	.2
Calcium	.1	Niobium	<1
Carbon	3	Nitrogen	5
Chromium	.3	Oxygen	5
Cobalt	.02	Silicon	<.1
Copper	.09	Tantalum	<3
Hydrogen	<1	Titanium	.01
Iron	.2	Vanadium	.05
Magnesium	<.01	Zirconium	.01

## MATERIALS AND EXPERIMENTAL PROCEDURE

Single crystals, nominally 1/8 inch in diameter and containing 0, 3, 5, 7, and 9 atomic percent rhenium, were prepared by zone melting of sintered and swaged powder compacts by utilizing the electron-beam apparatus described by Witzke (ref. 8). The desired orientation was produced by growth onto  $\langle 100 \rangle$  oriented seed crystals of unalloyed tungsten.

The orientations of all single crystals were determined by Laue back-reflection techniques to be within  $4^\circ$  of the  $[001]$  direction. Typical impurity levels of single-crystal rods are presented in table I. The rhenium contents of the crystal rods were within 0.5 percent of their nominal values.

These crystals were cut and centerless ground to buttonhead specimens with a reduced section 1.125 inches in length and

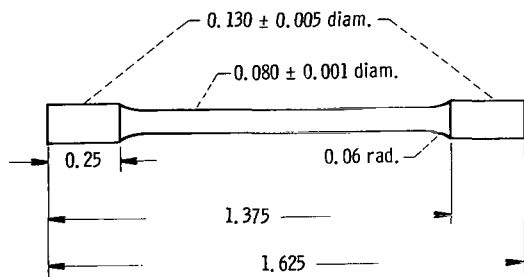

Figure 1. - Buttonhead tensile specimen (all dimensions in inches).

0.085 inch in diameter (fig. 1). On several specimens, 1/2-inch-long flats were ground in the reduced section parallel to specific crystallographic planes. The orientations of these flats were within  $4^{\circ}$  of the desired crystallographic planes. The worked surface layer of all specimens was removed by electropolishing in a sodium hydroxide solution to a depth of at least 0.005 inch.

Several tensile specimens of each composition (without flats) were fitted with foil strain gages having a gage length of 0.035 inch. Two gages were mounted at the midpoint of each specimen on opposite sides of the reduced section.

The tensile specimens were loaded on an Instron Universal Testing Machine. Strain was monitored through an external bridge circuit in which the specimen strain gages comprised two arms of the bridge. The bridge output was recorded against the applied stress.

## RESULTS

The room-temperature tensile behavior of the  $\langle 100 \rangle$  oriented tungsten and tungsten-rhenium single crystals is summarized in figure 2. Localized deformation was not observed until at least 3 percent strain.

The addition of rhenium had four distinct effects on the tensile behavior of tungsten single crystals:

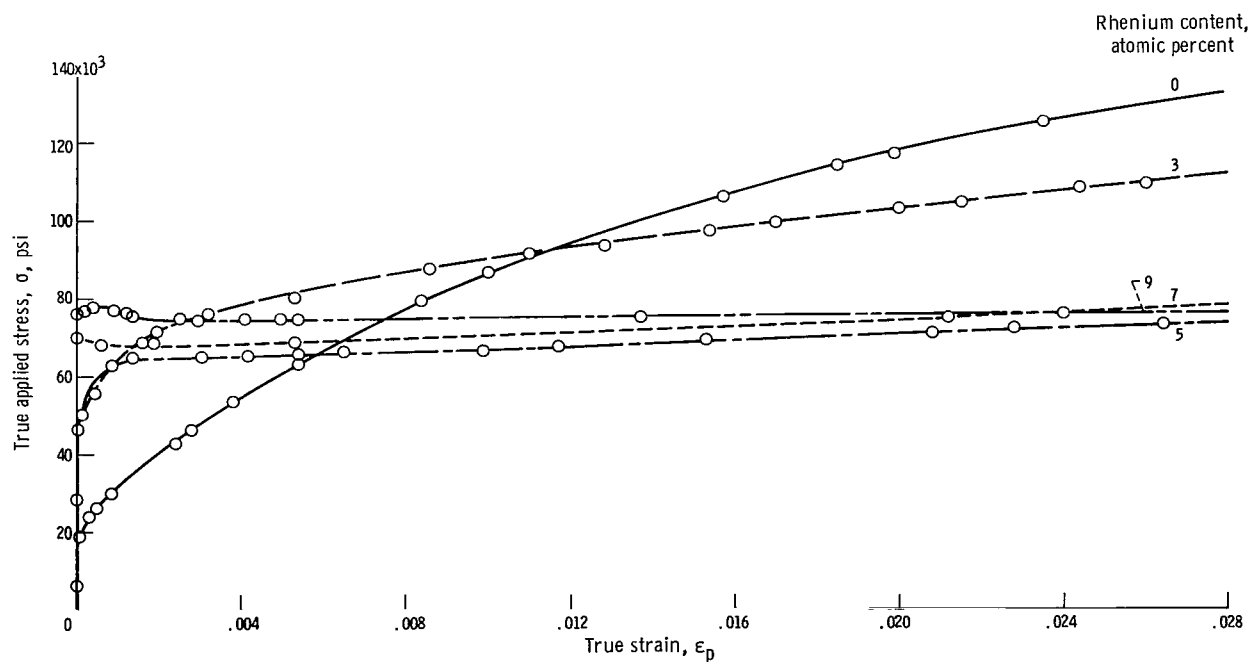

Figure 2. - Tensile curves of  $\langle 100 \rangle$  oriented tungsten single crystals containing various rhenium contents. Beyond 0.030 strain localized deformation occurs in 5, 7, and 9 atomic percent rhenium specimens.

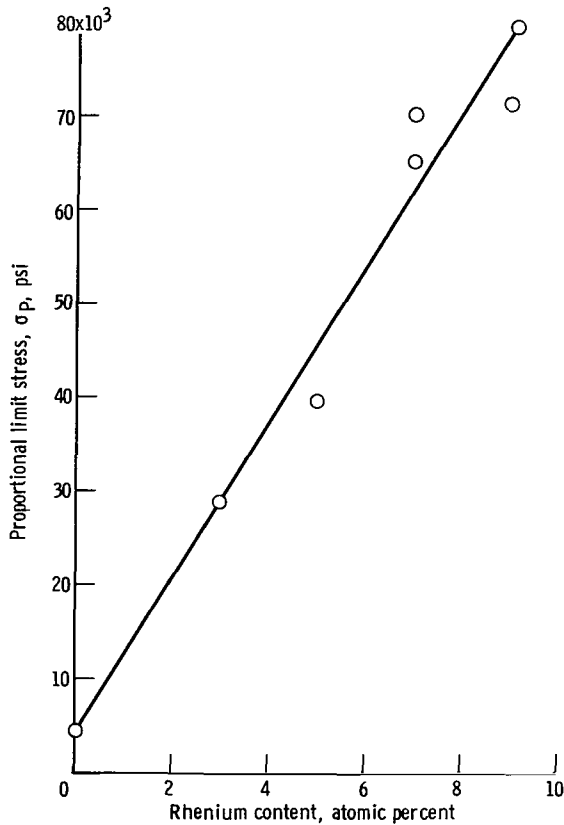

Figure 3. - Effect of rhenium on proportional limit stress of  $\langle 100 \rangle$  oriented tungsten single crystals.

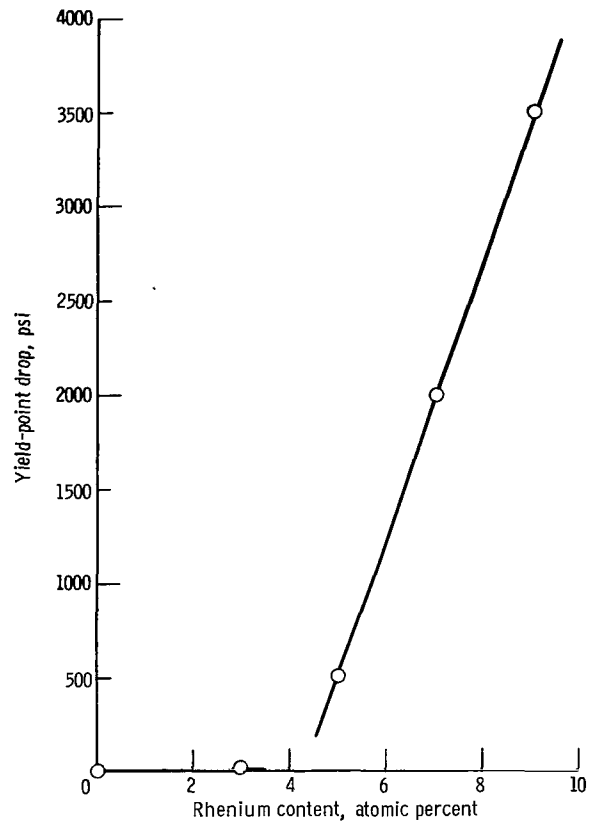

Figure 4. - Yield-point drop exhibited by  $\langle 100 \rangle$  oriented tungsten crystals with rhenium in solid solution.

(1) Rhenium increased the proportional limit stress. This effect is illustrated in figure 3. Because the tensile curves of the 0 and 3 atomic percent alloys did not show an abrupt transition from linear behavior, the proportional limit stresses of these alloys were determined by repeated reloading to successively higher stresses until nonlinear tensile behavior was observed.

(2) Rhenium promoted discontinuous yielding behavior at levels of 5 atomic percent and greater. The 5 atomic percent rhenium specimen exhibited elastic behavior until plastic flow began abruptly and continued at an essentially constant stress. Some 5 atomic percent rhenium specimens showed a small yield-point drop. The magnitude of the yield-point drop increases with increasing rhenium content above 5 atomic percent, as is illustrated in figure 4. When unloaded and immediately reloaded after yielding, a 9 atomic percent rhenium crystal did not exhibit a yield-point drop but began to yield at the same stress at which it had been when unloaded. After aging at  $1000^{\circ}\text{C}$  for 1/2 hour in a vacuum of approximately  $10^{-5}$  torr, the yield-point drop reappeared on reloading. An unalloyed specimen, similarly strained and aged, did not show a yield-point drop.

(3) The flow stress and work hardening rate decreased with increasing rhenium

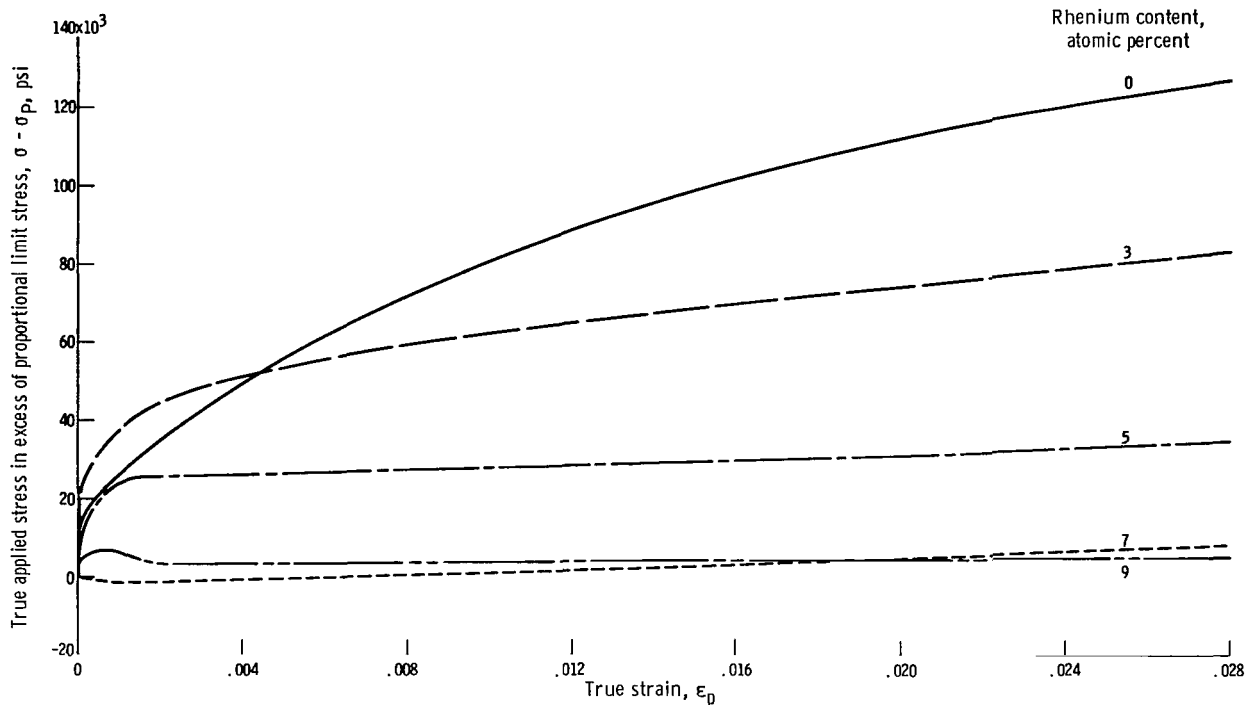

Figure 5. - Effect of rhenium on flow stress in excess of proportional limit stress of  $\langle 100 \rangle$  oriented tungsten single crystals.

content. Figure 5 illustrates the stress in excess of the proportional limit stress necessary to continue plastic flow.

(4) Rhenium increases the reduction in area at fracture of  $\langle 100 \rangle$  oriented crystals, as is illustrated in figure 6. All the crystals, regardless of rhenium content, failed by cleavage. From macroscopic examination, the cleavage plane appeared to be the (001) plane. The cross sections of the unalloyed and the 3 atomic percent rhenium crystals at failure were essentially circular. The cross sections of the 5, 7, and 9 atomic percent rhenium crystals, however, were elliptical.

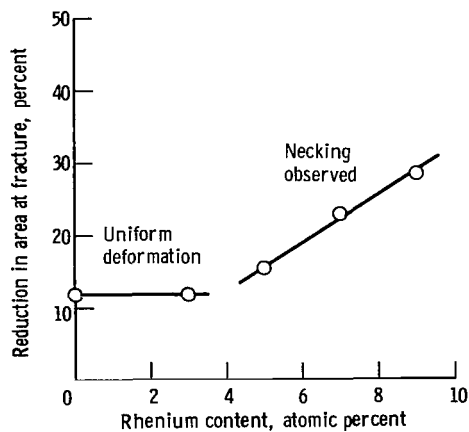

Figure 6. - Effect of rhenium on reduction in area of  $\langle 100 \rangle$  oriented tungsten single crystals.

failure were essentially circular. The cross sections of the 5, 7, and 9 atomic percent rhenium crystals, however, were elliptical.

The elliptical cross sections exhibited by the alloy specimens resulted from highly localized deformation, which began at approximately 3 percent elongation.

The 5 atomic percent rhenium specimen necked and then failed in the necked region. The 9 atomic percent rhenium specimen, however, necked to an essentially constant cross section, the length of which increased at the expense of the remaining circular cross-sectional material. The axes of the el-

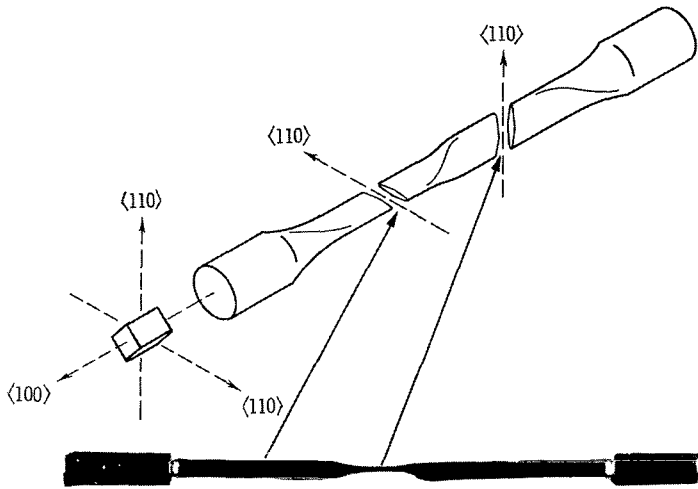

Figure 7. - Tungsten - 9 atomic percent rhenium tensile specimen after 15 percent strain.

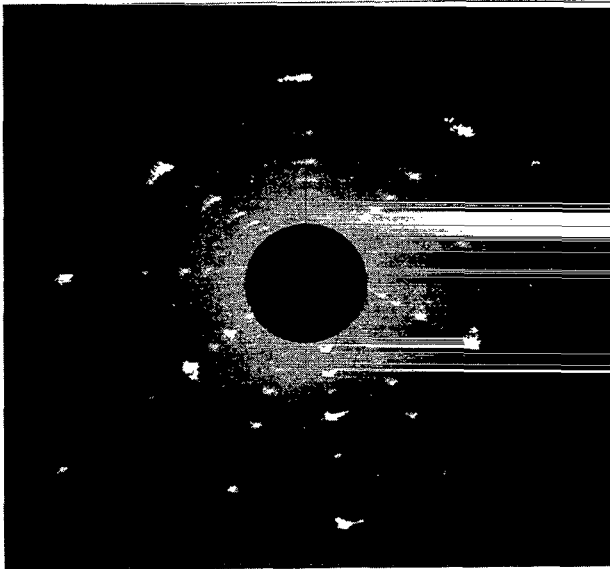

Figure 8. - Asterism exhibited by  $\langle 110 \rangle$  Laue back-reflection pattern of reduced section of tungsten - 9 atomic percent rhenium specimen.

liptical cross sections were always in  $\langle 110 \rangle$  directions.

Localized necking in the 9 atomic percent rhenium crystal often occurred in more than one region, and the necked portions finally joined to produce an elliptical cross section in the entire reduced section. In some cases, the major axes of the two necked regions were  $90^\circ$  apart, so that they could not join. Such a specimen is illustrated in figure 7. Once such a neck had formed, both the circular and elliptical regions of the 9 atomic percent rhenium specimens remained essentially constant in cross-sectional area during further plastic straining. The overall straining was accommodated by an increase in the length of the elliptical region at the expense of the circular region. Because the load during plastic flow was constant, the stresses in the circular and the elliptical regions were also constant and were calculated to be 74 000 and 141 000 psi, respectively.

An analysis of the asterism exhibited by a  $\langle 110 \rangle$  Laue back-reflection pattern of the elliptical region (fig. 8) on the 9 atomic percent rhenium specimen indicates that the crystallographic planes rotate about a  $\langle 110 \rangle$  axis during deformation. Total rotation of the tensile axis in this region was approximately  $4^\circ$ .



Slip behavior was studied on the 0, 5, and 9 atomic percent rhenium tensile specimens by examining slip traces on the (100) and ( $\bar{1}\bar{1}0$ ) oriented flats after straining in approximately 1 percent increments. Before reloading, the specimens were electrolytically repolished. This process was continued to fracture.

No slip traces were observed on the unalloyed tungsten specimens even after straining to failure (approx. 14 percent total elongation). This observation is similar to that in previous work (ref. 7), where traces were not observed until 10 percent strain on  $\langle 100 \rangle$  oriented tungsten crystals.

In view of this inability to observe slip traces on the as-deformed surfaces, an unalloyed tungsten crystal which had been strained 14 percent was etched and examined to see whether etching might reveal any evidence of the deformation mode. The etching revealed bright line traces, apparently corresponding to slip traces, which had not been visible on the as-deformed surface. On this particular specimen (illustrated in fig. 9), the flats were parallel to  $\{110\}$  planes,  $90^\circ$  apart. Two sets of lines were evident on each flat, one set between  $51^\circ$  and  $57^\circ$  and the other set between  $123^\circ$  and  $129^\circ$  to the tensile axis. These lines correspond to slip on  $\{110\}$  planes.

On a second unalloyed tungsten specimen, strained only 1 percent and similarly etched, etch pits were observed which defined a lamellar pattern (fig. 10). The lamellae

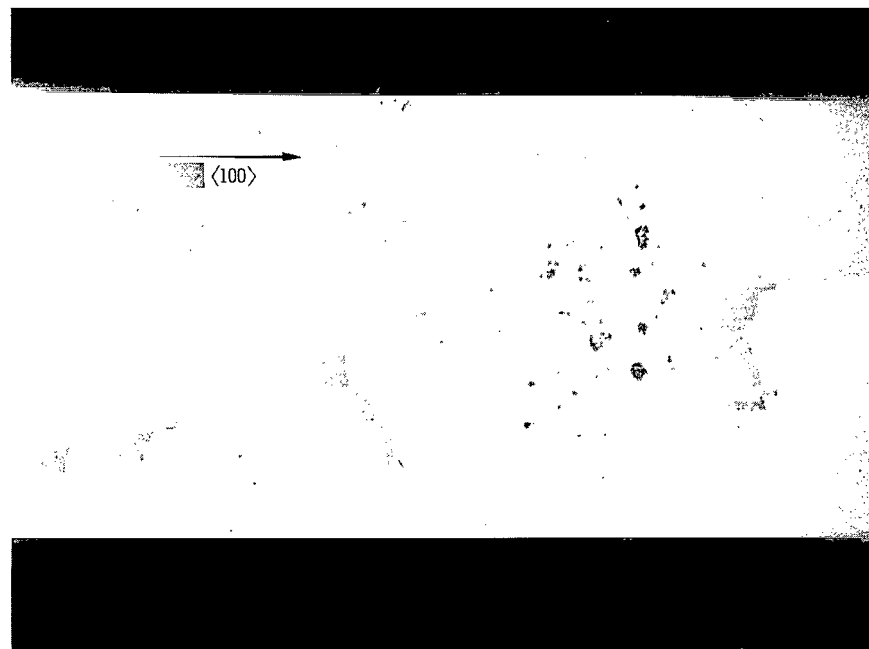

Figure 9. - Bright line traces on  $\{110\}$  flat of  $\{100\}$  oriented tungsten single crystal after 14 percent elongation. Etched with copper sulfate - ammonium hydroxide solution; X100.

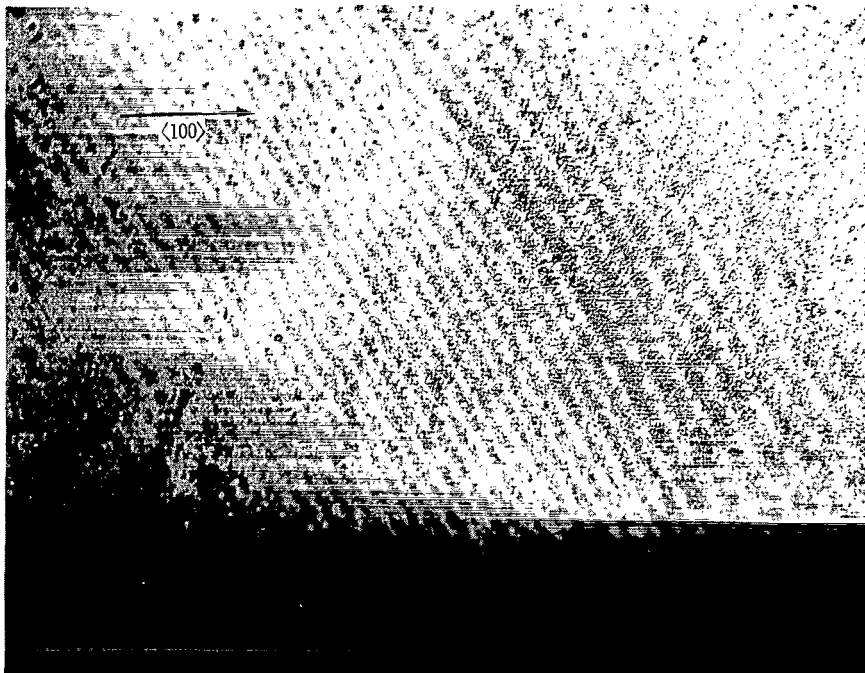

Figure 10. - Etch-pit pattern on {110} flat of {100} oriented tungsten single crystal after 1 percent elongation. Etched with copper sulfate - ammonium hydroxide solution; X250.

observed on the {110} face were  $54^\circ$  to the tensile axis. The {110} face was uniformly etched. If these lamellae correspond to slip traces in a manner analogous to the finding of Low and Guard (ref. 9) in silicon iron, then slip has occurred on a plane of the  $\langle 111 \rangle$  zone. This zone includes both {110} and {112} planes.

On another unalloyed specimen, also strained 1 percent and etched, etch pit lines were observed on a {100} face. These lines were at angles of  $25^\circ$ ,  $42^\circ$ ,  $61^\circ$ , and  $87^\circ$  to the tensile axis. The {112} planes of the  $\langle 111 \rangle$  zone intersect the {100} face at  $26.6^\circ$  and at  $63.4^\circ$ , while the {110} planes of this zone intersect the {100} face at  $45^\circ$  and at  $90^\circ$ . This observation indicates that both {112} and {110} are operating slip planes in unalloyed tungsten crystals at room temperature.

In contrast to the behavior observed in unalloyed tungsten, slip traces were readily visible on the unetched 5 atomic percent rhenium alloy after only 1 percent strain. The slip traces on the {110} flat were  $90^\circ$  to the tensile axis and wavy (fig. 11(a)). The traces on the {100} flat were straight (fig. 11(b)) and at an angle of  $61^\circ$  to  $67^\circ$  with the tensile axis. These observations are consistent with slip on {112} planes. In some regions,  $(\bar{1}12)$  slip predominated, while in other regions  $(1\bar{1}2)$  slip was more apparent. In intermediate regions, both slip planes were equally operative.

Essentially the same traces were visible in this alloy after 4 percent strain, with the traces being more distinct in the necked portions of the specimen. Traces attributable to {110} slip were found only in the necked region adjacent to the failure.

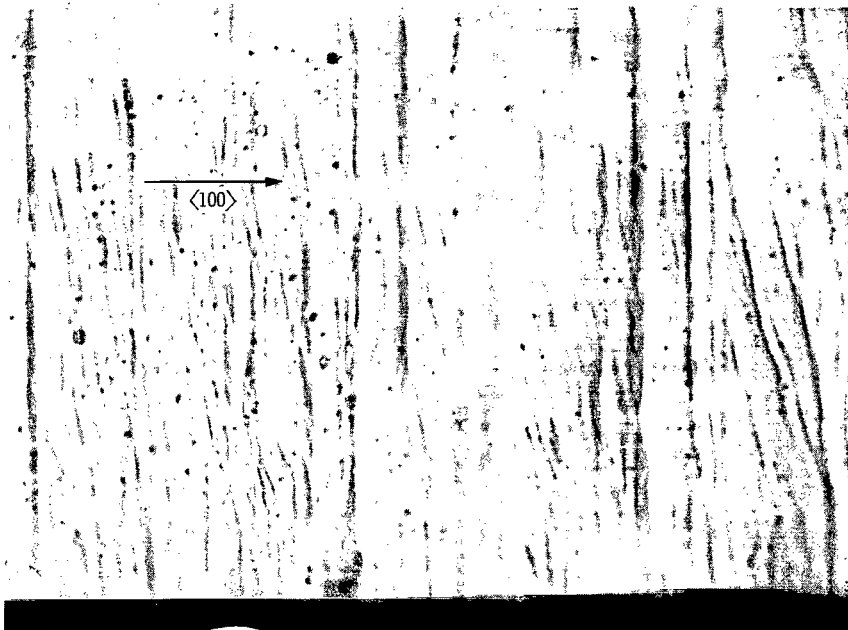

(a)  $\{110\}$  flat.

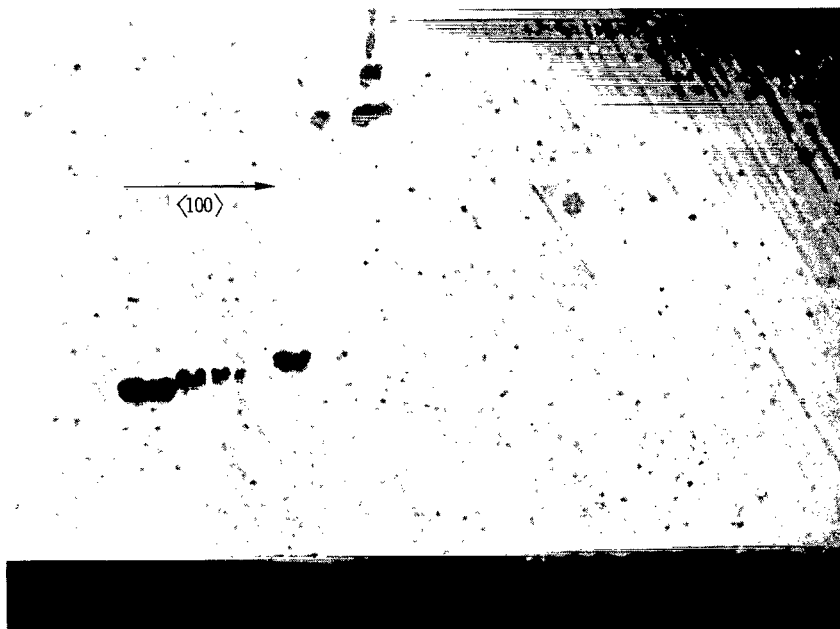

(b)  $\{100\}$  flat.

Figure 11. - Slip line traces on flats of  $\{100\}$  oriented tungsten - 5 atomic percent rhenium single crystal after 1 percent elongation. Unetched; X100.

Slip traces were distinct on the unetched 9 atomic percent rhenium specimen over the entire reduced section after 1 percent elongation. As in the case of the 5 atomic percent rhenium specimens, traces on the (110) flat were  $90^\circ$  to the tensile axis and wavy. On the (010) face, the traces were at angles of  $62^\circ$  and  $118^\circ$  to the tensile axis, which indicated both  $(\bar{1}12)$  and  $(1\bar{1}2)$  slip. Traces attributable to  $\{110\}$  slip were visible along the elliptical necked region only.

## DISCUSSION

The most noticeable effect of rhenium on the tensile behavior of  $\langle 100 \rangle$  oriented tungsten single crystals was the decrease in work-hardening rate with increasing rhenium content. Discontinuous yielding was observed at 5 atomic percent rhenium and higher, and the primary mode of deformation became  $\{112\}$  slip.

The processes involved in the deformation of  $\langle 100 \rangle$  oriented unalloyed tungsten crystals have not been well documented, because slip traces are not observable until considerable deformation has occurred. The etch-pit pattern observed in the present study after 1 percent elongation can be attributed to both  $\{110\}$  and  $\{112\}$  slip. Slip in unalloyed tungsten single crystals can thus be attributed to both  $\{112\} \langle 111 \rangle$  and  $\{110\} \langle 111 \rangle$  slip systems, which possibly leads to dislocation interactions that cause the high rates of work hardening observed.

The high degree of work hardening evident in unalloyed  $\langle 100 \rangle$  oriented tungsten single crystals may explain the difficulty in observing slip traces in the early stages of deformation. The amount of slip that can occur in any localized region may be so small that slip bands intersecting the surface are too narrow to be observed.

Work hardening is less evident for single crystals containing rhenium and is apparently virtually absent at a rhenium content of 9 atomic percent during uniform deformation.

Deformation in the 9 atomic percent rhenium alloy occurs by  $\{112\} \langle 111 \rangle$  slip. The slip direction was confirmed by the asterism exhibited by the  $\langle 110 \rangle$  Laue pattern of the deformed region, which indicates bending of crystallographic planes about a  $\langle 110 \rangle$  axis. The slip direction must be perpendicular to this axis of bending and in the slip plane (ref. 10). Only  $\langle 111 \rangle$  slip meets these conditions.

During necking, which started at approximately 3 percent strain, slip on  $\{112\}$  planes of the 9 atomic percent rhenium crystals was localized in the region joining the circular and elliptical cross sections of the specimen, which caused the elliptical region to increase in length. Since the tensile flow stress did not vary during plastic deformation, the resolved shear stress to sustain slip on the  $\{112\} \langle 111 \rangle$  system can be calculated as 35 000 psi. The resolved shear stress on the same  $\{112\} \langle 111 \rangle$  systems in the necked

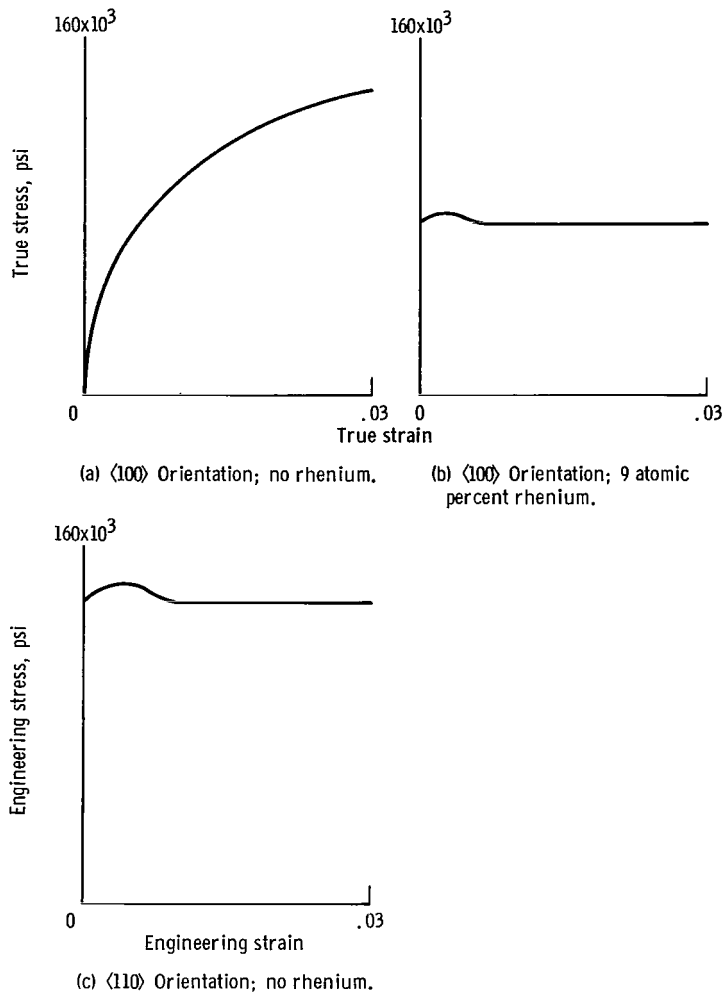

Figure 12. - Effect of orientation and rhenium content on tensile behavior of tungsten single crystals.

region was calculated to be much higher, 66 500 psi. Because  $\{110\}$  slip traces were visible only in the work-hardened elliptical necked region, slip on this plane apparently is suppressed in rhenium-containing crystals until a relatively high shear stress is achieved.

Discontinuous yielding in  $\langle 100 \rangle$  oriented crystals first became evident at a rhenium content of approximately 5 atomic percent. Both the yield-point drop and the previously discussed decrease in work hardening became more pronounced with increasing rhenium content up to at least 9 atomic percent, which suggests that these observed phenomena are probably related. In addition, the work-hardening behavior of the  $\langle 100 \rangle$  oriented 9 atomic percent rhenium crystals was similar to that previously observed for unalloyed  $\langle 110 \rangle$  oriented tungsten single crystals before necking (ref. 7), as is illustrated in figure 12. Both materials show upper yield points. Furthermore,  $\langle 110 \rangle$  oriented unalloyed

crystals neck to an essentially elliptical cross section with the major axes in the  $\langle 110 \rangle$  direction (ref. 11), as do the 9 atomic percent rhenium crystals. This behavior, along with asterism studies of the necked region of a  $\langle 110 \rangle$  oriented unalloyed crystal conducted by R. G. Garlick of Lewis, indicated that they both deform by slip on the  $\{ 112 \}$  plane. The flow stress of the  $\langle 110 \rangle$  oriented unalloyed tungsten crystal is, however, considerably higher than that of the  $\langle 100 \rangle$  oriented 9 atomic percent rhenium crystals.

Any mechanism of deformation speculated upon to explain the observed behavior must account for both the orientation and the rhenium effects. When pulled in the  $\langle 110 \rangle$  direction, a tungsten single crystal exhibits a yield point, and subsequent plastic flow is primarily by slip on  $\{ 112 \}$  planes. Such a yield point and slip system were not observed by crystals pulled in the  $\langle 100 \rangle$  direction unless they contained greater than 5 atomic percent rhenium in solid solution. The proportional limit stress of the rhenium-containing crystals was greater than that of the unalloyed  $\langle 100 \rangle$  oriented crystals. The proportional limit stress of the  $\langle 110 \rangle$  oriented unalloyed crystals was probably greater than that of the  $\langle 100 \rangle$  oriented crystals because their observed yield point occurred at a considerably greater stress than the initial flow stress of the  $\langle 100 \rangle$  oriented crystals.

Snoek (ref. 12) has suggested that an applied stress that produces a nonspherically symmetric lattice distortion can cause a redistribution of interstitials to particular sites and thus reduce the strain energy of the lattice. Furthermore, Nabarro (ref. 13) has pointed out that the stress field associated with a distorted lattice can strongly interact with the shear stress component of a dislocation stress field. Such an interaction could cause a redistribution of interstitials in the stress field of the dislocation. Schoeck and Seeger (ref. 14) have suggested that such a redistribution can reduce the strain energy of a dislocation.

If the applied stress considered is a tensile stress, the resulting lattice distortion will depend on the crystallographic direction of this stress, and, thus, so would also the distribution of interstitials in the stress field of the dislocation.

If the applied stress is in this  $\langle 100 \rangle$  direction, the resulting interstitial distribution might have only a negligible effect on the strain energy of dislocations and thus permit dislocation motion at a relatively low stress level on both  $\{ 110 \}$  and  $\{ 112 \}$  planes with a resulting high rate of work hardening.

Alternatively, the interstitial distribution resulting from a  $\langle 110 \rangle$  tensile stress might significantly decrease the strain energy of the dislocations and restrict their motion, which would thus prevent plastic flow until dislocation multiplication occurs primarily on  $\{ 112 \}$  planes.

The addition of rhenium to tungsten may affect interstitial-dislocation interactions, possibly the distribution of interstitials at dislocations. That rhenium can affect interstitial-dislocation interactions is suggested by the aging experiments. While a strained unalloyed  $\langle 100 \rangle$  oriented crystal does not exhibit a yield-point drop after aging,

a similar specimen, similarly strained and aged, containing 9 atomic percent rhenium does.

If such a redistribution significantly decreases dislocation strain energy, dislocation motion can be restricted. This restriction would prevent plastic flow until dislocation multiplication occurs on only the  $\{112\}$  plane, which would result in a yield-point drop. Plastic flow could then occur with little work hardening.

## SUMMARY OF RESULTS

The addition of rhenium to  $\langle 100 \rangle$  oriented tungsten single crystals had a significant effect on deformation behavior.

1. Rhenium additions both increased the proportional limit stress and decreased the flow stress of tungsten single crystals. While work hardening was appreciable in unalloyed tungsten, it was essentially nonexistent in the 9 atomic percent rhenium alloy until necking occurred.

2. Discontinuous yielding occurred at 5 atomic percent rhenium, with the magnitude of the yield-point drop increasing with increasing rhenium content. The yielding and flow behavior of the 9 atomic percent rhenium  $\langle 100 \rangle$  oriented crystals was similar to that exhibited by unalloyed  $\langle 110 \rangle$  oriented tungsten single crystals but at a much lower stress level.

3. Alloys with 5 atomic percent or more rhenium necked before failure; the cross section of the necked region was elliptical with axes in the  $\langle 110 \rangle$  direction. This deformation process involves bending of crystallographic planes about the  $\langle 110 \rangle$  axis. Similar behavior has been observed in the deformation of  $\langle 110 \rangle$  oriented unalloyed tungsten crystals.

4. While deformation of unalloyed crystals apparently involves slip on both  $\{112\}$  and  $\{110\}$  in the  $\langle 111 \rangle$  direction, the addition of rhenium promoted  $\{112\}$   $\langle 111 \rangle$  slip. Faint  $\{110\}$  slip traces were observed in the rhenium alloys only during necking. The 9 atomic percent rhenium alloy deformed uniformly only by  $\{112\}$   $\langle 111 \rangle$  slip;  $\{110\}$  slip traces were observed only in the elliptical necked region. This observation suggests that work hardening in tungsten may be associated with interference between the  $\{112\}$   $\langle 111 \rangle$  and  $\{110\}$   $\langle 111 \rangle$  operating slip systems.

5. A possible mechanism is proposed to elucidate both the effect of dilute rhenium additions observed in the present study and the orientation effect observed previously in unalloyed tungsten. Essentially, these observed phenomena are interpreted in terms of the orientation dependence of the sites occupied by interstitials in the stress field of dis-

locations when the lattice is elastically deformed and in terms of the effect of rhenium additions on the distribution of interstitials in tungsten.

Lewis Research Center,  
National Aeronautics and Space Administration,  
Cleveland, Ohio, October 8, 1965.

## REFERENCES

1. Allen, B. C. ; and Jaffee, R. I. : The Hardness Behavior of Chromium Alloyed with Group IV-A to VIII Transition Metals. ASM Trans. , vol. 56, no. 3, Sept. 1963, pp. 387-402.
2. Pugh, J. W. ; Amra, I. H. ; and Hurd, T. D. : Properties of Tungsten-Rhenium Lamp Wire. ASM Trans. , vol. 55, no. 3, Sept. 1962, pp. 451-561.
3. Ratliff, J. L. ; Maykuth, D. J. ; Ogden, H. R. ; and Jaffee, R. I. : Tungsten Sheet Alloys with Improved Low-Temperature Ductility. AIME Trans. , vol. 230, Apr. 1964, pp. 490-500.
4. Raffo, Peter L. ; Klopp, William D. ; and Witzke, Walter R. : Mechanical Properties of Arc-Melted and Electron-Beam Melted Tungsten-Base Alloys. NASA TN D-2561, 1965, p. 16.
5. Hoke, J. H. ; and Maddin, R. : Deformation of Molybdenum Single Crystals in Compression. J. Mech. Phys. Solids, vol. 5, no. 1, Nov. 1956, pp. 26-40.
6. Leber, Sam; and Pugh, J. W. : High-Temperature Slip in Tungsten. AIME Trans. , vol. 218, Oct. 1960, pp. 791-793.
7. Garlick, R. G. ; and Probst, H. B. : Investigation of Room-Temperature Slip in Zone-Melted Tungsten Single Crystals. AIME Trans. , vol. 230, Aug. 1964, pp. 1120-1125.
8. Witzke, W. R. : Zone Melting of Tungsten by Electron Bombardment. Proc. Symposium on Electron-Beam Melting, Boston (Mass. ), Mar. 20, 1959, p. 73.
9. Low, J. R. , Jr. ; and Guard, R. W. : Dislocation Structure of Slip Bands in Iron. Acta Met. , vol. 7, no. 3, Mar. 1959, pp. 171-179.
10. Maddin, R. ; and Chen, N. K. : Geometrical Aspects of the Plastic Deformation of Metal Single Crystals. Vol. 5 of Prog. in Metal Phys. , Pergamon Press, 1954, p. 53.



11. Rose, R. M. ; Ferriss, D. P. ; and Wulff, J. : Yielding and Plastic Flow in Single Crystals of Tungsten. AIME Trans. , vol. 224, Oct. 1962, pp. 981-990.
12. Snoek, J. L. : Effect of Small Quantities of Carbon and Nitrogen on the Elastic and Plastic Properties of Iron. Physica, vol. 8, no. 7, July 1941, pp. 711-733.
13. Nabarro, F. R. N. : Mechanical Effects of Carbon in Iron. Rept. Conf. Strength of Solids. Phys. Soc. (London), 1948, pp. 38-45.
14. Schoeck, G. ; and Seeger, A. : Flow Stress of Iron and Its Dependence on Impurities. Acta Met. , vol. 7, no. 7, July 1959, pp. 469-477.

3/22/45  
08

*"The aeronautical and space activities of the United States shall be conducted so as to contribute . . . to the expansion of human knowledge of phenomena in the atmosphere and space. The Administration shall provide for the widest practicable and appropriate dissemination of information concerning its activities and the results thereof."*

—NATIONAL AERONAUTICS AND SPACE ACT OF 1958

## NASA SCIENTIFIC AND TECHNICAL PUBLICATIONS

**TECHNICAL REPORTS:** Scientific and technical information considered important, complete, and a lasting contribution to existing knowledge.

**TECHNICAL NOTES:** Information less broad in scope but nevertheless of importance as a contribution to existing knowledge.

**TECHNICAL MEMORANDUMS:** Information receiving limited distribution because of preliminary data, security classification, or other reasons.

**CONTRACTOR REPORTS:** Technical information generated in connection with a NASA contract or grant and released under NASA auspices.

**TECHNICAL TRANSLATIONS:** Information published in a foreign language considered to merit NASA distribution in English.

**TECHNICAL REPRINTS:** Information derived from NASA activities and initially published in the form of journal articles.

**SPECIAL PUBLICATIONS:** Information derived from or of value to NASA activities but not necessarily reporting the results of individual NASA-programmed scientific efforts. Publications include conference proceedings, monographs, data compilations, handbooks, sourcebooks, and special bibliographies.

*Details on the availability of these publications may be obtained from:*

SCIENTIFIC AND TECHNICAL INFORMATION DIVISION  
NATIONAL AERONAUTICS AND SPACE ADMINISTRATION

Washington, D.C. 20546