

NASA TECHNICAL NOTE

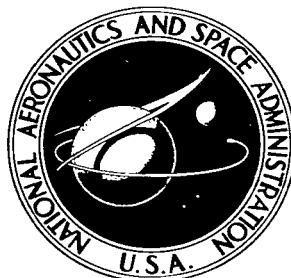

NASA TN D-3376

NASA TN D-3376

LOAN COPY
AFSC
KIRTLAND



IMP-I SPACECRAFT MAGNETIC TEST PROGRAM

by C. L. Parsons and C. A. Harris

Goddard Space Flight Center

Greenbelt, Md.



TECH LIBRARY KAFB, NM



0130244

NASA TN D-3376

IMP-I SPACECRAFT MAGNETIC TEST PROGRAM

By C. L. Parsons and C. A. Harris

Goddard Space Flight Center
Greenbelt, Md.

NATIONAL AERONAUTICS AND SPACE ADMINISTRATION

For sale by the Clearinghouse for Federal Scientific and Technical Information
Springfield, Virginia 22151 - Price \$1.35

ABSTRACT

The magnetic tests of the IMP-I spacecraft (Explorer XVIII) include both individual component and integrated spacecraft test results. By having incorporated component testing in the early stages of the program, it was possible to obtain the following information: (1) individual component magnetic field disturbance magnitudes, (2) possible spacecraft field contribution due to assembled components, (3) to determine which components have excessive magnetic field, (4) a means by which excessive field could be reduced, and (5) possible results due to perming and deperming effects.

Based upon the magnetic test results and upon the telemetered in-flight data, the design goal (magnetic) for the IMP-I was achieved.

CONTENTS

| | |
|---|----|
| Abstract | ii |
| INTRODUCTION. | 1 |
| TEST OBJECTIVES | 2 |
| TEST PLAN | 2 |
| Components Magnetic Field Measurements | 2 |
| Spacecraft Magnetic Field Measurements | 3 |
| TEST RESULTS. | 3 |
| Components. | 3 |
| Spacecraft. | 6 |
| CONCLUSIONS AND RECOMMENDATIONS | 13 |
| Components. | 13 |
| Spacecraft. | 15 |
| ACKNOWLEDGMENT | 15 |
| Bibliography | 16 |
| Appendix A—Description of Spacecraft. | 17 |
| Appendix B—Test Facilities | 19 |
| Appendix C—Test Procedure | 29 |
| Appendix D—Test Activity Log | 43 |
| Appendix E—Components Magnetic Test Data Summary Table | 45 |
| Appendix F—Components Magnetic Test Reports | 53 |
| Appendix G—Facet C Comparison Data | 69 |
| Appendix H—Atlantic Missile Range Magnetic Field Survey | 77 |
| Appendix I—Perming Effects of Tools and Equipment. | 83 |
| Appendix J—Spacecraft Magnetic Check at Fredericksburg, Va. | 87 |

IMP-I SPACECRAFT MAGNETIC TEST PROGRAM

by

C. L. Parsons and C. A. Harris

Goddard Space Flight Center

INTRODUCTION

The need for the inception of a detailed magnetic test program for the IMP-I Spacecraft became apparent due to the stringent requirements for a *magnetically clean* spacecraft in order to insure the success of the magnetic field experiments. To achieve this goal, it was deemed necessary to incorporate separate magnetic tests and design goals for both the spacecraft and its associated components.

When the initial component test data were combined and extrapolated to the distance of 72 inches by assuming identical moment orientation *blackest picture*, the results obtained are listed in Table 1.

As the components test program proceeded and as analysis and reduction tests were performed for diminishing the magnetic field disturbance of various components, it was possible to reduce the computed (components) spacecraft post deperm magnitude from 2.4 to 1.4 gamma. In addition, the stray magnetic field magnitude was reduced from 3.3 to 0.5 gamma.

Concurrent with and subsequent to the components test program, complete spacecraft magnetic tests were performed in order to satisfy the following conditions:

1. to insure the fabrication of a *magnetically clean* spacecraft with a magnetic field disturbance of less than 0.5 gamma at the flight detector positions,
2. to determine maximum magnetic field disturbance magnitudes due to 25-gauss exposure (simulating maximum vibrational exposure field magnitudes),
3. to determine possible perming effects due to all phases of environmental background field exposure.

Table 1

Component Data - Computed Spacecraft
Magnetic Field Disturbance

| Magnetization | Extrapolated Magnitude (gamma at 72 inches) |
|---------------|--|
| Initial Perm | 6.8 |
| Post Exposure | 30.2 |
| Post Deperm | 2.4 |
| Stray | 3.3 |

Table 2

Measured Spacecraft Total Magnetic Field Disturbance.

| Magnetization | Magnitude (gamma at 72 inches) |
|------------------------|-----------------------------------|
| Initial Perm | 1 |
| Post 25 Gauss Exposure | 13.5 |
| Post 50 Gauss Deperm | < 0.5 |
| Stray | < 0.5 |

The necessary spacecraft data were obtained by conducting a series of four magnetic tests which included the required exposure and deperm treatments. Table 2 summarizes the results of the magnetic test data obtained, and indicates the measured spacecraft magnetic field disturbance at the spin axis (72-inch) position.

These data indicated a total magnetic field disturbance of less than 0.25 gamma at the three flight sensor positions.

In the case of the components, the magnetic field measurements were performed at the Goddard Space Flight Center, Component Magnetic Test Facility, (CMTF); whereas, the spacecraft tests were performed at the Naval Ordnance Laboratory Magnetic Test Facility, Building 206.

The purpose of this report is to present in detail the results of the IMP-I magnetic test program and the corresponding magnetic tests which were performed during the pre-launch life of the spacecraft. After launch this spacecraft was redesignated as Explorer XVIII.

TEST OBJECTIVES

The IMP-I magnetic test program was formulated in order to achieve the following objectives:

1. Obtain design control information pertaining to the magnetic field disturbance of the individual spacecraft components.
2. Perform analysis and reduction tests on those components the magnetic field of which exceeds the design goal limits.
3. Survey the integrated spacecraft to ascertain that the magnetic field disturbance at the flight sensor positions does not exceed the design goal limits, thereby affecting the performance of the magnetometers.
4. Perform the necessary pre- and post-environmental measurements and exposure tests in order to obtain control data to compile a complete magnetic history of the spacecraft and to establish the stability of the magnetic state of the spacecraft.

TEST PLAN

The IMP-I spacecraft magnetic test plan was separated into two categories.

Components Magnetic Field Measurements

The spacecraft component magnetic field measurements were primarily performed at the Component Magnetic Test Facility, GSFC (refer to Appendix B-1) between August 9, 1962 and November

22, 1963. These component measurements generally included an initial test (pre-environmental) and a final test (post environmental). When applicable in the case of some components, various analysis and reduction tests were also performed. Appendix C-1 outlines the component test procedure as adopted for measurements at the Component Magnetic Test Facility.

Spacecraft Magnetic Field Measurements

Due to the limitations of the Component Magnetic Test Facility, i.e., size, fixturing, and perm-deperm capability, the spacecraft magnetic field disturbance measurements were performed at the Naval Ordnance Laboratory Magnetic Test Facility, Building 206 (refer to facility description in Appendix B-2) by GSFC Magnetic Test Section personnel with the assistance of NOL personnel. Four separate magnetic tests were performed at the NOL facility: deperm, initial, post vibration, and final. Appendix C-2 details the spacecraft magnetic test procedure for these tests as conducted at the NOL facility. Two separate spacecraft tests were performed prior to the environmental test sequence (balance, thermal-vacuum, and vibration) and subsequently, in order to determine the effects of the environmental testing, a special post-vibration exposure test was conducted. At the conclusion of the final vibration and balance tests, and prior to launch, the fourth and final magnetic test was performed.

TEST RESULTS

Components

The IMP-I spacecraft components and integral parts magnetic field measurements were initiated in August 1962, and at this time, tests were performed on magnesium samples, which were to be utilized in the University of Chicago experiment. The actual components measurements began later in December 1962, when an initial test was conducted on the Ames Proton Analyzer. Appendix D-1 is a log which summarizes the history of the component measurements. Since the Proton Analyzer's post 25-gauss exposure magnetic field disturbance magnitude was quite high (138 gamma at 18 inches), additional analysis and reduction tests were performed on the component and its integral parts. These tests indicated that the primary source of magnetic field contamination was the nickel wiring utilized within the circuit of the unit. As a result of subsequent changes made by the experimenter, the magnetic field of this unit was then reduced to an acceptable level (post 25-gauss exposure magnitude less than 32 gammas at 18 inches). Data pertaining to this component as well as all other components tested, are presented in the component summary table included in Appendix E. In addition to the Proton Analyzer, several other units had excessive perm fields. These units, after having been measured initially (as received state), were tested and analyzed in order to locate the possible sources of magnetic field contamination and subsequently *cleaned up*. Table 3 lists six components, the percentage of perm field reduction achieved and, the contributing sources of contamination. Further information pertaining to the analysis and reduction tests and the sources of contamination is included in Appendix F.

Table 3

Components Perm Field Reduction Results.

| Component | Perm Field Magnitude in Gamma at 18 inches | | Reduction (%) | Prime Source of Magnetization |
|-----------------------|---|-------|---------------|-------------------------------|
| | Initial | Final | | |
| Proton Analyzer | 138.4 | 7.4 | 95 | Nickel Wiring |
| Prime Converter | 117.6 | 60.5 | 49 | Wiring and Components |
| Ion Chamber | 51.4 | 7.2 | 86 | P. S. Electronics Board |
| R vs dE/dx | 118.0 | 21.6 | 82 | Photo Tubes and Leads |
| Programmer #4 | 34.0 | 4.8 | 86 | Relay |
| Relay and Despin Card | 275.2 | 21.5 | 92 | Relay |

The problems encountered in the reduction of the permanent magnetic field disturbances varied with the component; notwithstanding this, the prime contributors were found to be wiring and leads, i.e., nickel ribbon wire, capacitor leads, and numerous transistor leads. An example of the problems presented by magnetic wire leads would be a photo-multiplier tube (refer to R vs dE/dx test report Appendix F). When exposed, the photo-multiplier tube (similar to that in the R vs dE/dx telescope) was measured and determined to have a field magnitude of 71.1 gamma at 18 inches. When the leads were clipped short and measured separately by simulating the same special arrangement resulting from being attached to the tube, a field magnitude of 61.5 gamma was measured. By having cropped the leads as short as possible, the perm field of the tube was reduced 86 percent. Not only is it important to avoid the use of magnetic wiring in the construction of components, but, in addition, inner-connecting wire should also be non-magnetic. In the case of one range and range-rate unit (refer to Appendix F), it was determined that the harness had increased the perm field of the unit as much as 77 percent. Furthermore, the importance of continuous magnetic testing of parts and components cannot be overemphasized even when specified non-magnetic materials are utilized. To cite an example, one can refer to the case of the IMP spacecraft wiring harness (Appendix F) which supposedly contained non-magnetic wire. In this particular instance *one* black insulated wire, 26 gauge was found to be magnetic while other sizes of the black wire, in addition to all other colors, were non-magnetic.

Another source of magnetic field disturbance which can be troublesome occurs when relays are incorporated in components. Two possible solutions to this problem are cancellation by placing two relays back-to-back or replacement by selecting other equivalent types which are known to be less magnetic. The relay replacement method was utilized in the case of the programmer #4 card (Appendix G) and the relay and despin card by replacing the original relays with ones whose magnetic field was 1/10 as large (refer to components summary table Appendix E). Stray field (power on) analysis and reduction tests were also conducted on those components which exhibited excessive stray field magnetization. Table 4 lists such components and indicates the percentage reduction of the associated stray field achieved by compensation. As would be expected, units

Table 4

Components Stray Field Reduction Results.

| Component | Stray Field Magnitude in Gamma at 18 inches | | Reduction (%) | Current (amperes) |
|-----------------------|--|-------|---------------|-------------------|
| | Initial | Final | | |
| Battery | 87.2 | 4.9 | 95 | 3 |
| Prime Converter | 87.7 | 4.2 | 95 | 2.5 |
| Performance Parameter | 14.6 | 1.6 | 93 | 5&2 |
| E vs dE/dx | 46.6 | 3.5 | 93 | 0.08 |

operating with currents above 1 ampere have rather high stray fields and require special attention. In the event where one is attempting to construct a *magnetically clean* spacecraft as in the case of the IMP, even low operating currents can generate excessive fields and require compensation, i.e., E vs dE/dx.

To prevent the creation of outside stray fields which might lead to erroneous stray field readings during the stray-field measurements, tightly twisted pair leads were used to connect the component to the external power supply. In order to achieve stray field reduction, two techniques were utilized: (1) rewiring the circuit to avoid current loops and (2) adding to the circuit special compensation loops. When the compensation loops were used to reduce or cancel the stray field (method 2), it became necessary to conduct additional tests in order to determine the most effective loop size and position required for obtaining the desired field levels (stray field disturbance of <5 gamma at 18 inches). As indicated in Table 4, over 90 percent stray field reduction was accomplished for each of the four listed components. Although the stray field could be reduced to a level of 10 gamma without much difficulty, for those levels of less than 10 gamma the positioning of the compensation loop became quite critical. Thus, to insure that the loop had not shifted appreciably after having been properly located, post-plotting checks were also performed.

The E vs dE/dx power supply is one example of a part which employed compensation loops (Appendix F). With the proper number of compensation loops, it was possible to reduce the stray field at 18 inches from 7.5 to 2.4 gamma for this sample unit. As a result, by compensating the power supply it was further possible to reduce the stray field of the complete unit. In effect, these compensation loops can either be return current leads whose fields are in opposition to that of the offending source or, they can consist of an expanded auxiliary loop which has been twisted 180 degrees to obtain the desired cancellation. Again in the case of the E vs dE/dx experiment, a problem arose with the use of a non-toroidal inductor which because of its permeable material, created a stray field problem. By switching to a toroid, this problem was thereby eliminated.

Due to the fact that the components (and spacecraft) are exposed to magnetic fields in excess of the ambient geomagnetic field (0.6 gauss) especially during the vibration phase of the environmental

test sequence, an investigation was conducted to determine the effects of this exposure. Since the vibrator table stray field magnitudes fall within the 0.5 to 25 gauss range, tests were performed to determine what percentage of perming might be expected to occur when components are exposed to these fields. In addition, deperm tests were included in order to compare the results of individual card deperm in relation to assembled facet deperm. The detail description and results of these tests is included in Appendix G. Summarizing briefly, the overall results obtained indicated that

1. satisfactory deperming results can be obtained by either deperming the individual components or the complete assembly,
2. components in a demagnetized state (depermed) change little as a result of vibration in earth's field (0.6 gauss),
3. components exposed to and vibrated in fields exceeding 0.6 gauss tend to perm or deperm according to the magnitude and direction of the applied field.

In the components test program it is of some interest to note that the perm and stray field reduction was achieved without the use of shielding. Although it is possible to reduce magnetic fields by the use of certain shielding materials, the use of these materials was not adopted in the case of the IMP spacecraft program due to the problems presented by the use of such material.

Particular attention was devoted to ensure that the solar paddles did not contribute appreciable perm nor stray magnetic field disturbances at the magnetometer sensor position (approximate distance from center of paddle to fluxgate is 3 feet). In September 1963, the prototype solar paddle was measured. This paddle had a perm field of 0.3 gamma at 24 inches, a magnitude well within the design goal limits. Because of late delivery problems, the flight solar paddles were not readily available for testing at GSFC. Although, as indicated in the case of the first paddle, the flight paddles would not be expected to have significant perm fields, quick checks at Atlantic Missile Range (AMR) revealed irregularities in the perm fields of these paddles. As a result, it became necessary to measure and deperm the paddles in order to select four which would be magnetically acceptable. Further detailed surveys indicated that 5 of the 10 paddles had sizeable and unacceptable perm fields (caused by the use of Kovar instead of copper strips in the construction of the paddles) and it then became necessary to rebuild these paddles for future flight use. In order to obtain paddles with a minimum stray field, special back-wiring techniques (developed by the magnetic fields experimenter) were employed to achieve effective compensation. Each cell module was back-wired within the paddle structure so that individual cell breakdown would not change the required compensation currents.

Early tests conducted by the magnetic fields experimenter indicated that it was possible to reduce the stray field of the pre-prototype paddle from a magnitude of 1.25 gamma to 0.5 gamma (distance = 75 cm) thus achieving a 60 percent stray field reduction.

Spacecraft

To fulfill the magnetic test requirements established for the IMP-I spacecraft, a series of four spacecraft magnetic tests were performed between the months of August and October 1963. The

Table 5

IMP-I Spacecraft Magnetic Tests.

| No. | Test | Measurements | Condition | Date |
|-----|--------------------------------|----------------------------------|--------------------|------------|
| 1. | Deperm | Perm, Deperm | Pre-Environmental | 8/8/63 |
| 2. | Initial | Perm, Exposure, Stray, Deperm | Pre-Environmental | 8/12-13/63 |
| 3. | Post Environmental Exposure | Perm | Post Vibration | 9/16/63 |
| 4. | Final | Perm, Deperm | Post Environmental | 10/23/63 |

tests which were performed and the corresponding test procedures have been previously discussed under the test plan for spacecraft magnetic field measurements. Table 5 indicates the four tests, dates, and the specific measurements conducted.

Each of these tests included initial perm* and post deperm (when applicable) data, whereas, the initial test (August 12-13, 1963) included exposure and stray field measurements as outlined in the spacecraft test procedure (Appendix C-2). Although the spacecraft tests provided valuable design control data, the primary goal of these tests was to ensure that the magnetic field disturbance attributed to the spacecraft was less than 0.25 gamma at the flight detector positions. In addition to the actual spacecraft tests, special tests and magnetic surveys were performed in order to determine those areas and those possible conditions which might tend to produce substantial changes in the magnetic field characteristics of the spacecraft; i.e., environmental testing and AMR pre-launch checks. The background magnetic field surveys of environmental test areas in Building 7, GSFC (thermal-vacuum, solar simulation, and vibration) indicated the presence of ambient background fields whose magnitudes corresponded to that of the regional geomagnetic field (0.6 gauss) except in the near vicinity of the vibration exciter tables. (Appendix G, Tables IV and V). In the case of the vibrators, the dc-field magnitudes ranged from 1 to 25 gauss depending upon the type of exciter table and the relative location about the table. By performing measurements on the spacecraft before and after the vibrational tests, it was possible to determine any magnetic field change which had occurred as a result of the vibrational field exposure. These data combined with the facet-C test results (Appendix G) provided reliable information concerning the perming effects which might be expected in the case of the IMP spacecraft. Additionally, it was possible to determine the perming effects resulting from normal spacecraft handling and movement by measuring the spacecraft before and after transporting the spacecraft to and from GSFC, NOL, and Fredericksburg Magnetic Observatory (FMO). In July 1963, a special magnetic-field survey was performed by Magnetic Test Section personnel at the Atlantic Missile Range in order

*Initial perm measurements are performed during the various magnetic tests by measuring the permanent magnetization of the item while it is in the "as received" state and should be differentiated from other permanent magnetization states (Post Exposure, Post Deperm). The purposes of these initial measurements are (1) to show one possible level of perm which may exist for a newly manufactured item of the same design, (2) to obtain data which would indicate what significant changes, if any, occurred after the previous test measurements, and (3) to obtain a relative magnitude of field which is used to determine the effectiveness of the deperm treatment.

to obtain ambient magnetic field data. The three areas in which the spacecraft ordinarily would be located were surveyed at this time; i.e., checkout and storage building, spin facility, and launch complex. Although it was determined that the ambient magnetic-field magnitude was less than 1 gauss (Appendix H), a check was conducted on hand tools on a rack located in the spin facility and some were found to possess substantial magnetic fields. As a result of the AMR tool measurements, additional data were obtained at the Component Test Facility, GSFC, that illustrated the possible magnetizing effects resulting from the use of magnetic tools (Appendix I). Since tools of this type are normally used when working on the spacecraft, special provisions were made to insure that these tools remained in a demagnetized state by the use of a portable ac deperming coil.

Deperm Test Results

On August 8, 1963, prior to a calibration of the spacecraft fluxgate and rubidium magnetometers* at the controlled zero field coil facility at Fredericksburg Magnetic Observatory, the IMP-I spacecraft was delivered to the NOL Test Facility, Building 206, for a magnetic survey and

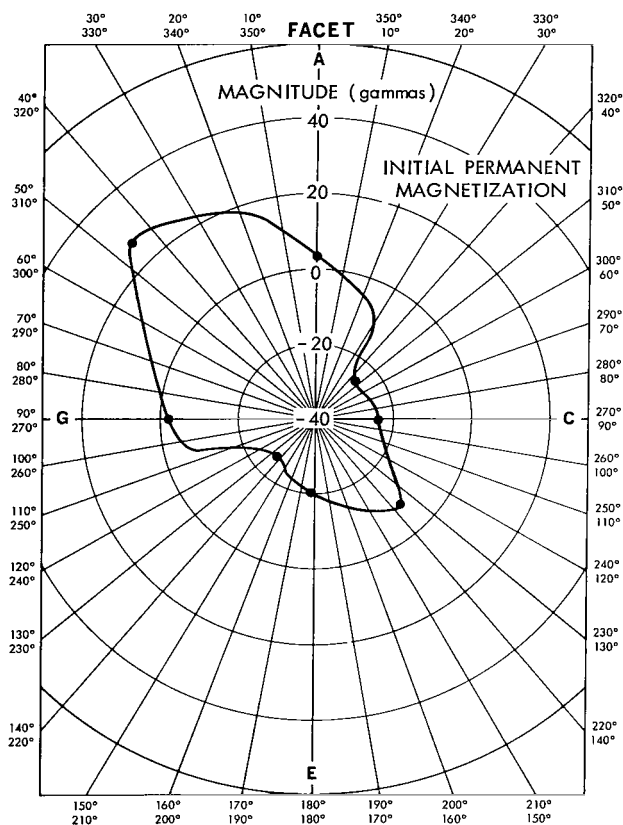

Figure 1—Magnetic field disturbance of spacecraft - Radial component (H_x). Initial permanent magnetization in gamma at 27.8 inches.

deperm. At this time, the magnetic field disturbance of the spacecraft was measured and both rotational and *fall-off* data were obtained (refer to the IMP-I spacecraft magnetic test procedure included in Appendix C-2). Figure 1 is a polar graph representation of the magnetic field disturbance (radial component) of the spacecraft as initially measured. It should be noted that a simple dipole representation was not achieved due to the fact that the field magnitude was not measured at a distance of at least 3 times the overall dimension of the spacecraft (90 inches). Figure 2, indicates the facet arrangement for the spacecraft and its associated components. Because of the low fields associated with the spacecraft, particularly after deperming (Figure 3), the measurements were performed at the indicated nearer distance. By referring to the magnetic-field change-versus-distance curves (fall off) shown on the logarithmic graphs in Figure 4, one notes that the radial component field diminished by the $1/r^5$ instead of the expected $1/r^3$. However, then the data are readjusted so that the center of the facet nearest the detector (facet F) is considered to be the source of field (a reasonable assumption due to the facet

*In the case of the calibration checks at FMO, these checks were performed by the experimenter with the assistance of FMO personnel. Appendix J outlines the calibration procedure as performed with the IMP-I spacecraft.

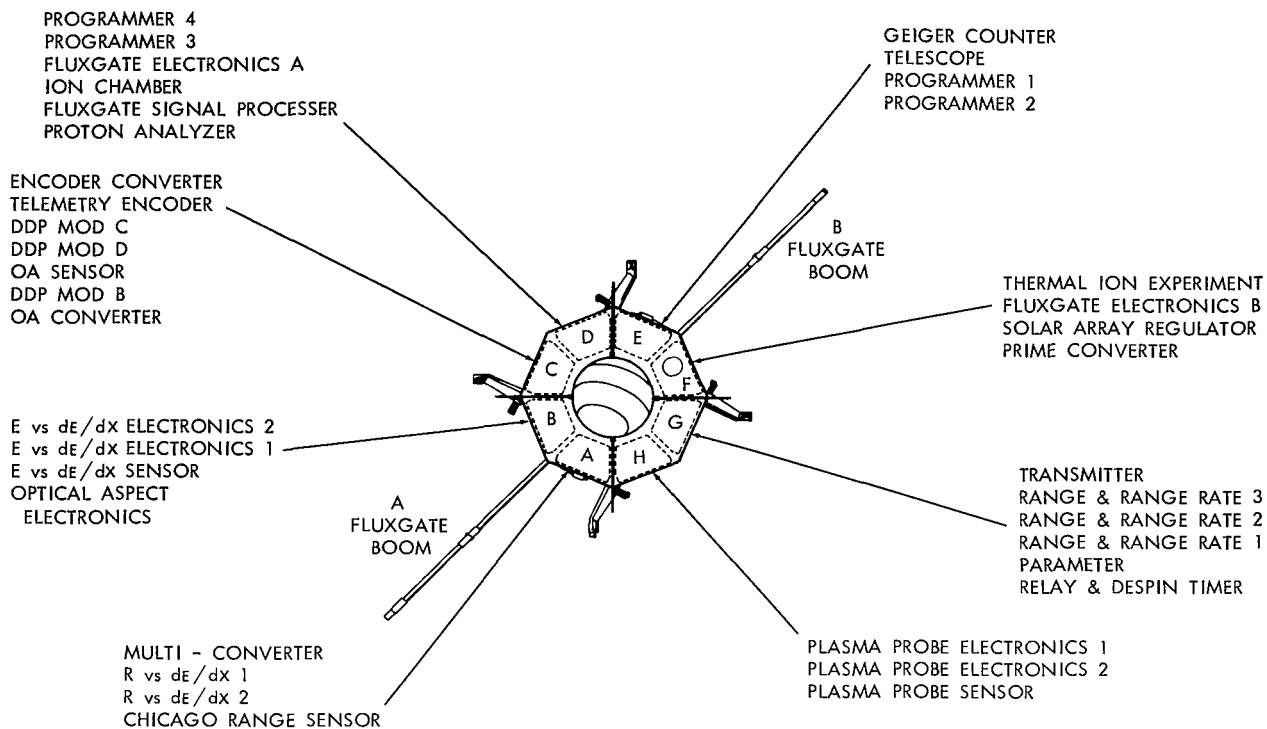

Figure 2—IMP-I (Explorer XVIII) Spacecraft.

configuration and separation distances) the field falls off by the $1/r^3$. In Figure 4, the fall-off data shows the spacecraft field magnitude to be less than 0.5 gamma at the sensor position. At the conclusion of the initial perm measurements, the spacecraft received a spin axis deperm (Appendix C-2 III E), and was then remeasured. The peak-to-peak rotational data obtained indicated that the vertical component (H_z) magnitude of the spacecraft field had been reduced 71 percent (from 7 to 2 gamma). In the case of the radial component (H_x), only a 53 percent reduction was achieved (60 gamma to 28 gamma); however, after a second deperm treatment with the field directed along the horizontal axis of the spacecraft (Appendix C-2 III D) the peak-to-peak magnitude was reduced to 5 gamma (a 92 percent reduction of the initial magnitude). At the completion of the full deperm treatment, the magnetic field disturbance at the three detector positions was less than 0.5 gamma. In addition, the resultant magnetic moment of the spacecraft was less than 31 cgs units.

Initial Test - August 12-13, 1963

Following the spacecraft magnetometer performance checks at FMO, the spacecraft was returned to NOL for intensive perm and stray checks. After the brief initial perm measurements, the spacecraft was then exposed (spin and horizontal axes) to a 25 gauss dc field. While in the exposed state, rotational and fall-off data were obtained. In this state it was determined that the magnetic moment of the spacecraft had increased by a factor of twelve (moment magnitude of ≥ 377 cgs units). Although the field of the spacecraft in the exposed state was quite high, the data obtained

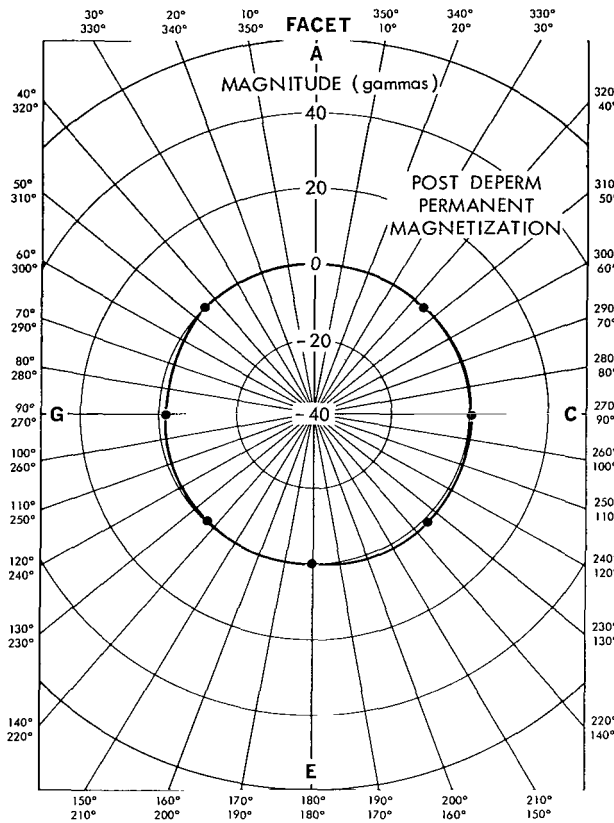

Figure 3—Magnetic field disturbance of spacecraft - Radial component (H_x). Post deperm permanent magnetization in gamma at 27.8 inches.

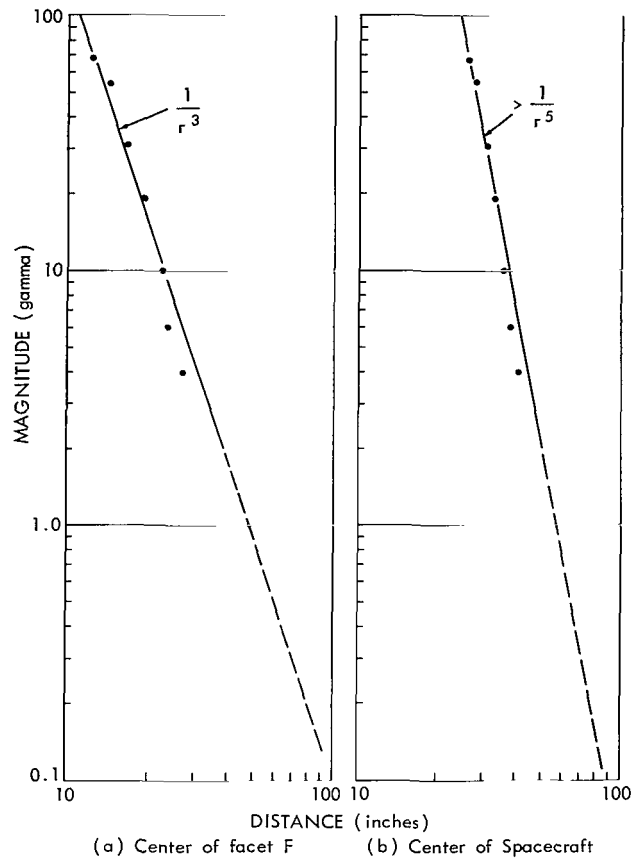

Figure 4—Magnetic field change versus distance (fall-off) from Facet F. Initial perm.

during the component tests tended to indicate such an increase could be expected with the application of a 25-gauss exposure field. Figure 5, is a polar graph which represents post exposure magnetic field disturbance of the spacecraft as measured at the mid-height and 27.8-inch distance position. Again, in the case of fall-off, the post exposure magnetic field along the fluxgate "A" boom axis exceeded the inverse cube power (3.5 power); however, with the facet center distance adjustments the inverse cube falloff is substantiated as indicated in Figure 6. In the case of the measurements along the spin axis, as shown in Figure 7 an inverse cube falloff could be directly related to the center of the spacecraft (mid-height of facets). Upon application of the deperming treatment, the field of the spacecraft (exposed state) was reduced to a level comparable to the post deperm magnitude on August 8, 1963. Table 6 tabulates the magnetic field disturbance magnitudes at the three flight detector positions for the initial perm, post exposure and post deperm conditions and includes as well the other test results. Figure 3 shows that at a distance of 27.8 inches (from the center of the spacecraft), the magnetic field disturbance is approaching a magnitude of less than 1 gamma after deperming. Since the perm measurements were made with the spacecraft non-operative (no power), separate measurements were obtained with the spacecraft power on. Figure 8 is a polar graph which represents the stray magnetic field change which occurred as power was applied to the

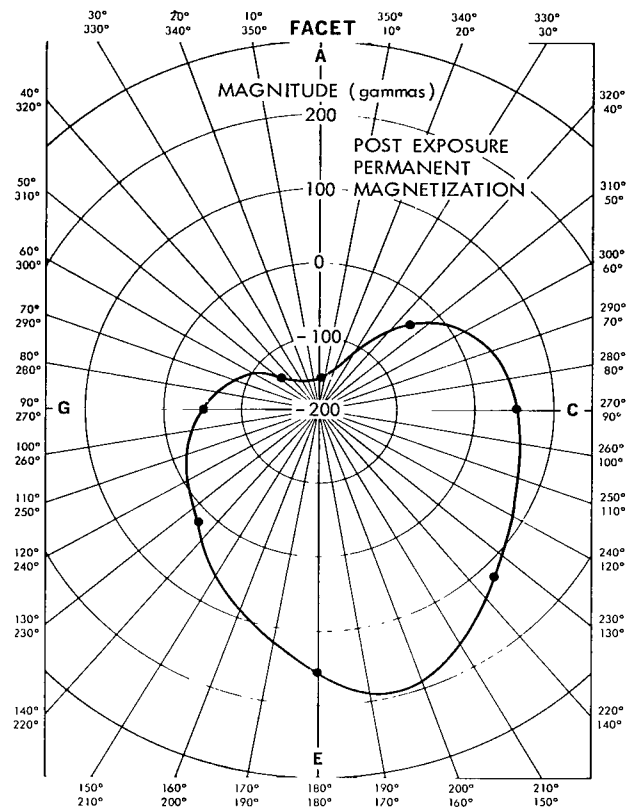

Figure 5—Magnetic field disturbance of spacecraft - Radial component (H_x). Post exposure in gamma at 2.7 inches.

spacecraft. As indicated in Figure 8, an 11 gamma stray field disturbance existed in the direction of facet H. Also, as the thermal Ion and Electron (I&E) experiment calibration cycle occurred, an additional stray field pulse of 11 gammas was detected. Since this field was not directed towards either fluxgate A or B and is of short duration it does not affect the magnetometers;* thus the stray magnetic field disturbance is less than 1/2 gamma at the flight detector positions (refer to Table 6).

The stray magnetic field measurements also included a check on the solar paddle loading circuit in order to detect any large stray field loops which might have been created by improper wiring.† The spacecraft measurements were performed without the solar paddles attached to the spacecraft; however, separate detailed solar paddle magnetic surveys were conducted at the Component Magnetic Test Facility (refer to Appendix E for component summary table data). The stray magnetic field moment of the spacecraft was determined to be ≤ 30 cgs units.

*The I&E experiment is not normally energized by the spacecraft power system during the magnetic field measurements. These five current calibration steps occur at a time other than during the Rb magnetometer measuring sequence.

†An example of such a magnetic field disturbance is that of the UK II spacecraft, which had a spin axis stray field magnetic field disturbance of 3 gamma at a distance of 53-3/4 inches from the center of the spacecraft that was attributed to such a circuit.

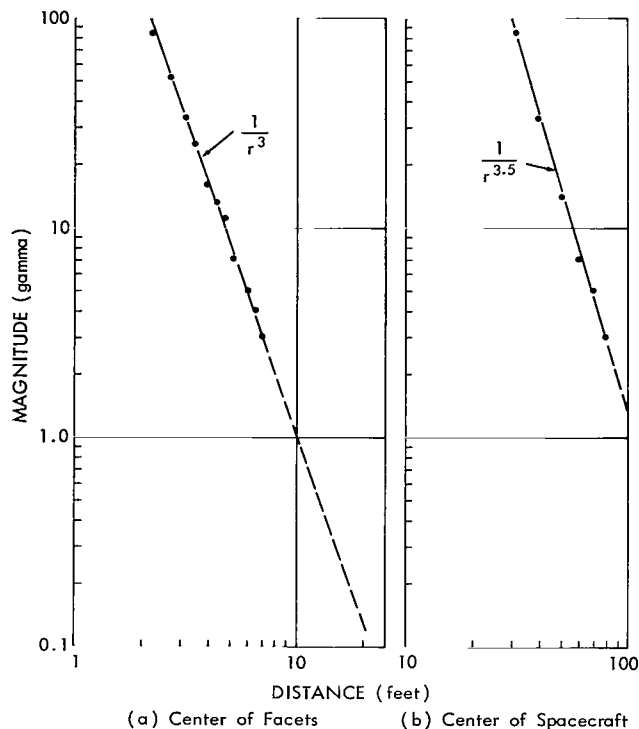

Figure 6—Magnetic field change versus distance (fall-off) along fluxgate-A boom Axis. Post exposure.

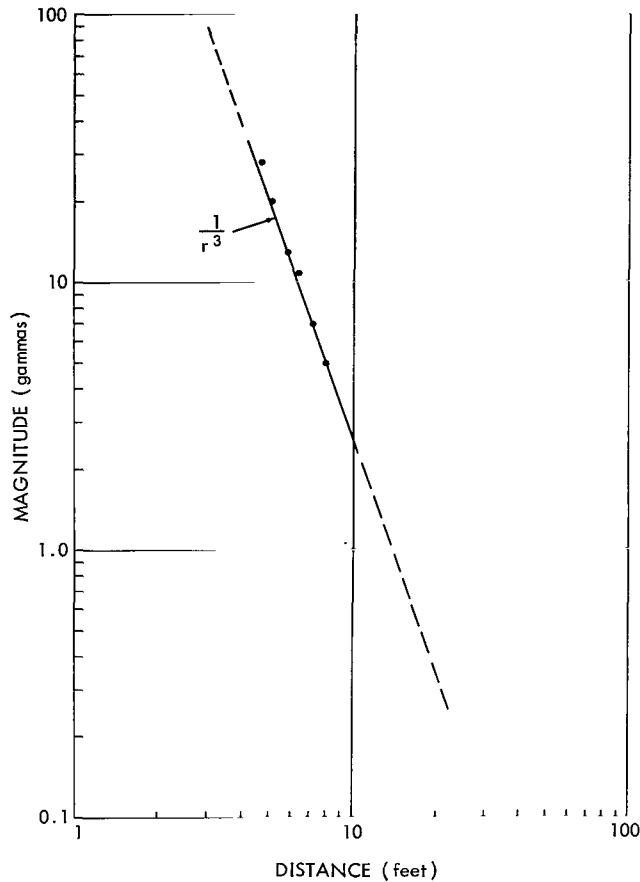

Figure 7—Magnetic field change versus distance (fall-off) along spin axis. Post exposure.

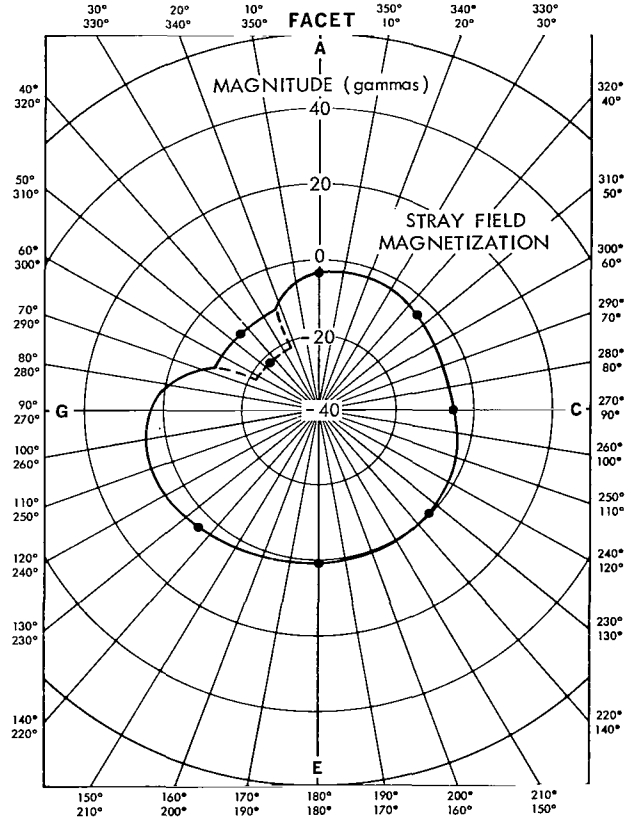

Figure 8—Stray magnetic field disturbance of spacecraft - Radial component (H_x). (Magnitude in gamma at 27.8 inches.)

Table 6
IMP-I Spacecraft - Magnetic Test Results,
Total Magnetic Field Disturbance in Gamma at Flight Sensor Positions

| Magnetization | Test Date | Fluxgate "A" 82 ^{11*} | Fluxgate "B" 82 ^{11*} | Rubidium | |
|---------------|-----------|-----------------------------------|-----------------------------------|--------------------|-------------------|
| | | | | 65 ^{11**} | 72 ^{11*} |
| Initial | 8/8/63 | <1 | <1 | - | - |
| Post Deperm | 8/8/63 | <1/2 | <1/2 | <1/2 | <1/2 |
| Initial | 8/12 | - | - | - | - |
| Post Exposure | 8/12 | 7 | 4 | ≤19 | 13.5 |
| Post Deperm | 8/13 | <1/2 | <1/2 | <1/2 | <1/2 |
| Stray | 8/13 | <1/2 | <1/2 | <1/2 | <1/2 |
| Initial | 9/6 | <1/2 | <1/2 | 2 | 1.5 |
| Initial | 10/23 | <1/2 | <1/2 | 10 | 7 |
| Post Deperm | 10/23 | <1/2 | <1/2 | <1 | <1 |

*Measured

**Extrapolated by $1/r^3$.

Final Test - October 23, 1963

The IMP-I spacecraft received a final deperm prior to being shipped to AMR. At this time the spacecraft was measured initially, depermed, and then remeasured. Although initially a magnetic field disturbance of 7 gamma was measured at the spin axis detector position of 72 inches, this field was reduced to less than 1 gamma after the deperm treatment. In addition, the mid-height peak-to-peak magnetic field disturbance was reduced 65 percent (from 34 to 12 gamma) resulting in a magnetic field disturbance at the fluxgate sensor position of less than 0.5 gamma. At the time of this test, the geiger counter telescope was not integrated in the spacecraft (facet E); however, it was depermed separately prior to integration into the spacecraft (refer to component test summary table in Appendix E). Since the spacecraft was revibrated between the time of the post-vibration test and the final test, this field of 7 gamma (spin axis) equivalent to a perm increase of 54 percent, indicates that the spacecraft had been exposed to a field with a magnitude of approximately 10 gauss.

CONCLUSIONS AND RECOMMENDATIONS

Components

The value of the components magnetic test program has been demonstrated simply on the basis of the final test results obtained. These data which show the magnetic field disturbances of numerous components whose magnitudes were reduced to desirable design goal limits are presented in the components summary tables in Appendix E. In addition, the overall effectiveness of the test program can be shown by combining all the components* data (normal spacecraft composition) and comparing the initial test magnitudes with the final test results. Table 7 separately totals both the initial test results and the successive or final test condition results. With these data it is also possible to determine the overall perm and stray field reduction achieved. The percentage reduction for each condition is also indicated in Table 7.

Table 7
Component Magnetic Field Reduction Results.

| Magnetization | Magnetic Field Magnitude in Gamma at 18 inches | | Reduction (%) |
|---------------|---|---------------|---------------|
| | Initial Results | Final Results | |
| Initial Perm | 431.9 | 160.3 | 63 |
| Post Exposure | 1932.9 | 1396.5 | 28 |
| Post Deperm | 152.9 | 89.8 | 42 |
| Stray | 209.4 | 33.0 | 85 |

*The simplest method of summarizing was adapted (i.e., all moments are considered to have the same orientation) so that it was possible to add the component magnitudes to obtain the total magnitude. Due to the design of the spacecraft and the component fabrication techniques, it is expected that the individual cards would have quite similar magnetic moment orientations. This would be the case especially subsequent to the 25-gauss exposure where the moments would be directed primarily along the spin axis of the spacecraft.

When the final test data tabulated in Table 7 is extrapolated to the spin axis distance of 72 inches compared with the measured spacecraft magnitude, the value of the component testing becomes apparent. Without the component test program, it would not have been possible to successfully integrate the components into the spacecraft and fulfill the design goal requirements as indicated in Table 8. In regard to the orientation of the moments of the individual components, Table 8 also shows the percentage compensation which occurred.

Table 8

Component and Spacecraft Magnetic Test Summary Table.

| Magnetization | Total Magnetic Field Disturbance in Gamma at 72 inches | | |
|---------------|---|------------|------------------|
| | Components | Spacecraft | Compensation (%) |
| Initial Perm | 2.5 | ≤ 1 | ≥ 60 |
| Post Exposure | 21.8 | 13.5 | 38 |
| Post Deperm | 1.4 | < 0.5 | > 64 |
| Stray | 0.5 | < 0.5 | -- |

In the beginning of the components test program, provisions were made for deperming the components in a dc-field of 25 gauss (identical to exposure field magnitude). Later, with equipment changes, it was possible to increase the deperm field magnitude to 50 gauss (identical to spacecraft deperm field magnitude). By comparing the results obtained in the case of facets C and E versus dE/dx electronics units 1 and 2 for the two different levels of deperm, it became apparent that the percentage deperm increased 10 percent in the case of E and #1 and #2, and 19 percent in the case of the facet C (these data are also presented in Table 9). At the conclusion of the component test program, the deperm field was changed to 50 gauss ac. In the case of the IMP-I it has not been possible to present data indicating the relative effectiveness of ac versus the type of dc depermitted; however, subsequent component test data tend to favor the ac deperm as being more effective. In the matter of time required to perform the component tests, a full magnetic survey required less than 4 hours (due to features of the Component Magnetic Test Facility), whereas the time required for the final survey could be reduced by one half. Although it has been possible to present the results of the IMP magnetic test program, what cannot be shown are the contributions of all those connected with the program without whose efforts such results could not have been achieved.

Table 9

Deperm Field Results.

| Magnetization | Magnitude in Gamma at 18 inches | | Deperm (%) | |
|-----------------|---------------------------------|-------------|------------|-------------|
| | Facet C | E vs dE/dx* | Facet C | E vs dE/dx* |
| Pre Deperm | 97.4 | 46.5 | | |
| 25 Gauss Deperm | 31.4 | 7.3 | 64 | 84 |
| 50 Gauss Deperm | 11.8 | 3.0 | 83 | 94 |

*For electronics units #1 and #2.

Spacecraft

Based upon the magnetic test results and the in-flight measurements,* the IMP-I aptly achieved the magnetic field disturbance design goal by providing an integrated spacecraft whose total magnetic field disturbance was less than 0.25 gamma at the extended flight sensor positions. Although, as indicated by the component test results, it was possible to produce a magnetically clean spacecraft, deperm treatments were utilized in order to remove any perming effects which may have resulted from the environmental test sequence. Because of the structural arrangement of the spacecraft and the location of the rubidium magnetometer, particular attention was paid to the radial component field magnitude along the spin axis. The measurements and tests performed concerning the possible perming effects resulting from exposure during environmental testing combined with the in-flight results* indicated that the spacecraft could be depermed after the environmental tests and then be expected to remain in this depermed state through calibration checks, earth's field exposure, shipping, and probably through launch.

The overall results obtained have clearly indicated the success of the IMP magnetic test program; and, even though the results obtained with successive IMP spacecraft have been as fruitful, the data obtained have indicated that minor physical changes can cause a significant change in the magnetic field characteristics of a spacecraft even where similar components are utilized. As a result, continued, if not intensive, component and spacecraft testing is important to insure the further success of the program. The IMP-I was the first of a new spacecraft series, and as such, much was learned about the magnetic testing of this type of a spacecraft. Consequently, with the testing of successive IMP spacecraft, i.e., 02, 03, certain additional refinements have been utilized in the tests which have added even more background information as well as improving the relative accuracy of the measurement data.

ACKNOWLEDGEMENT

A major portion of the burden of insuring the assembly of a magnetically clean spacecraft was assumed by the magnetic fields experimenter, Dr. Norman F. Ness, and members of his section who actively participated in the magnetic test program.

The success of the component test program was due in part to the availability of the Component Magnetic Test Facility at the Goddard Space Flight Center. Mr. William D. Kenney was the principal engineer responsible for the design and development of this facility which was efficiently operated by members of the Magnetic Test Section.

Magnetic tests of the completed spacecraft were performed at the Magnetic Test Facility at the U. S. Naval Ordnance Laboratory. The cooperation and assistance of Mr. James Ford and members of the facility staff is gratefully acknowledged.

*Ness, N. F., C. S. Searce, and J. B. Seek, Initial Results of the IMP-I Magnetic Field Experiment, *J. Geophys. Res.*, 69(17):3542, September 1, 1964.

The calibration of flight magnetometers was performed at the Fredericksburg Magnetic Observatory of the Coast and Geodetic Survey, of the Environmental Services Administration. The cooperation and assistance of Mr. Richard Kuberry and members of the observatory staff is gratefully acknowledged.

BIBLIOGRAPHY

- Heppner, J. P., Ness, N. F., Scarce, C. S., and Skillman, T. L., "Explorer 10 Magnetic Field Measurements," *J. Geophys. Res.* 68(1):1-46, January 1, 1963.
- Ness, N. F., Scarce, C. S., and Seek, J. B., "Initial Results of the Imp I Magnetic Field Experiment," *J. Geophys. Res.* 69(17):3531-3569, September 1, 1964.
- Ness, N. F., "The Magnetohydrodynamic Wake of the Moon," *J. Geophys. Res.* 70(3):517-534, February 1, 1965.
- Ness, N. F., "Magnetic Field Restraints for IMP's F and G," GSFC Document X-672-64-167, July 1964.
- Ness, N. F., "The Earth's Magnetic Tail," GSFC Document X-612-64-392, December 1964 (revised, January 1965).
- Ness, N. F., and Wilcox, J. M., "On the Solar Origin of the Interplanetary Magnetic Field," GSFC Document X-612-64-250, August 1964.

Appendix A

Description of Spacecraft

The IMP-I (Explorer XVIII) has an octagonally shaped main body (Figure A-1) 28 inches in diameter and 9 inches in depth. The satellite has four solar paddles, each 26 inches long by 20 inches wide, mounted 90 inches apart. Because of the extreme sensitivity of the fluxgate magnetometers and the rubidium 87 vapor magnetometer, the magnetic field sensing elements were located on booms at a position remote from the spacecraft. Figure A-2 shows the locations of these sensors and their distance from the center of the spacecraft.

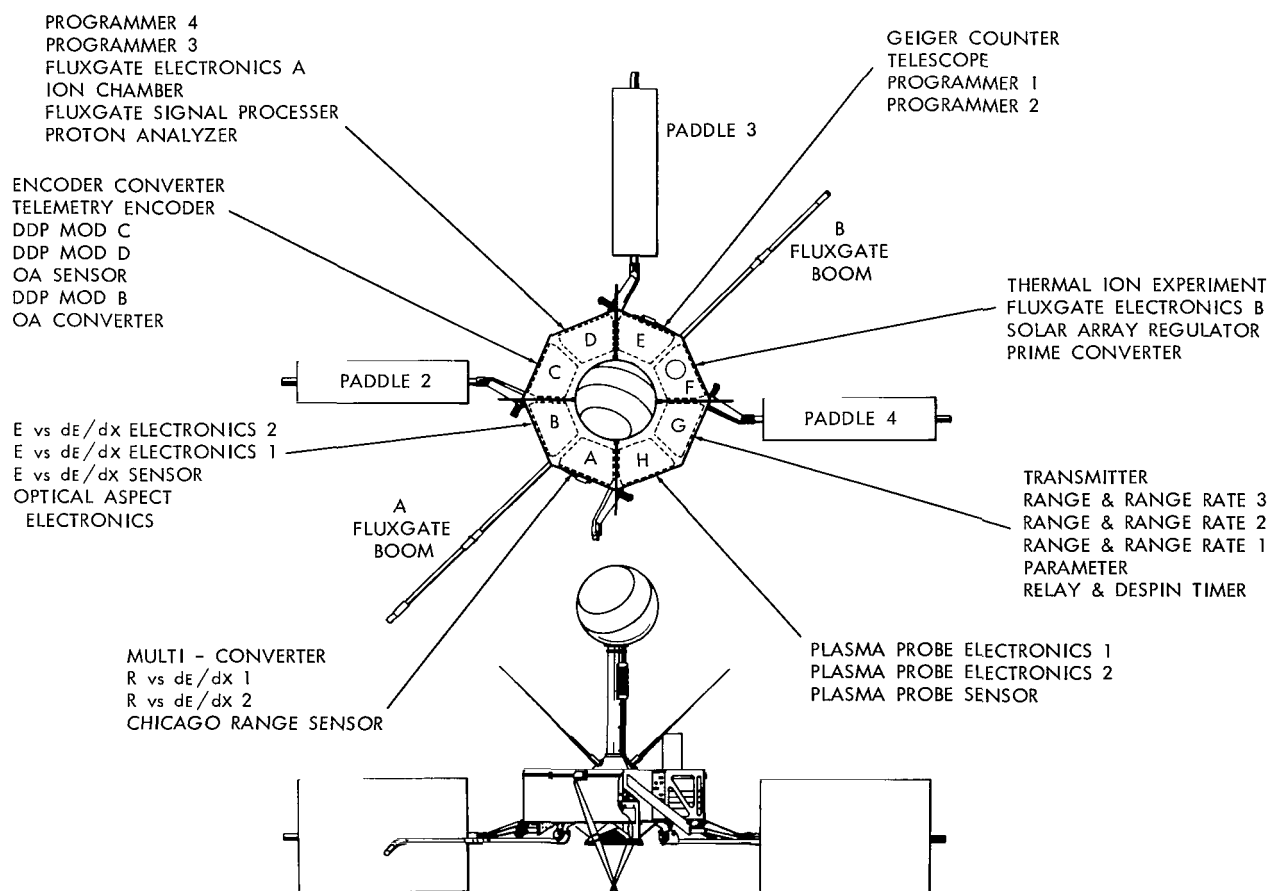

Figure A-1—Interplanetary Monitoring Probe (IMP, S-74).

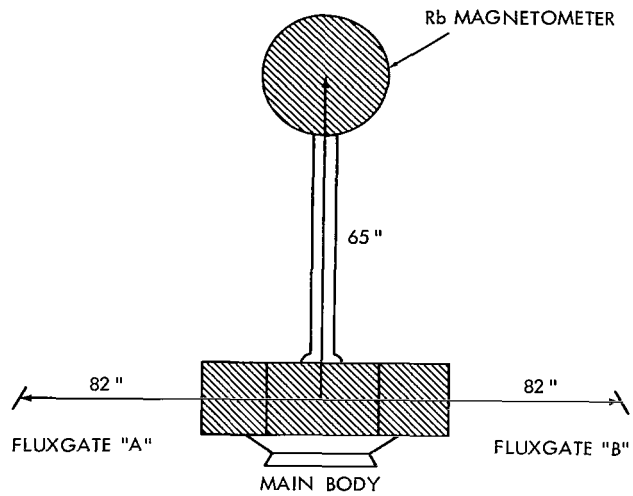

Figure A-2—Sketch of the IMP Spacecraft illustrating location of fluxgate and rubidium magnetometer sensor.

Appendix B

Test Facilities

B-1 Component Magnetic Test Facility - (CMTF-GSFC)

Introduction

The Component Magnetic Test Facility was built primarily as a zero magnetic field facility for the testing of OGO spacecraft components. By the addition of a smaller sized gimbal fixture, the facility fulfilled the magnetic field measurement requirements of the IMP spacecraft program.

For a complete description of this facility see GSFC Document No. X-325-65-312, dated July 1965, entitled Component Magnetic Test Facility - Operations and Test Procedure Manual.

Building

The Component Magnetic Test Facility is housed in a wooden frame building (Figure B-1) $20 \times 20 \times 20$ feet in size. Because of the urgent needs of the OGO program, the building was constructed of conventional materials, i.e., wood, concrete, steel nails, steel bolts, and composition roofing. However, within the confines of the coils, all materials used are non-magnetic.

Coil System

The CMTF coil system consists of three orthogonal sets of square modified Helmholtz coils (Figure B-2) with a spacing of $b = 0.6a$ (a = side length of coil). Table B-1 summarizes the dimensions and constants for the coils.

Normally, the coils are operated in the zero field mode by producing the following cancellation fields under the listed current conditions:

| <u>Coil</u> | <u>Current (amps)</u> | <u>Field (gamma)</u> |
|----------------|-----------------------|----------------------|
| X | 1.22 | 13,200 |
| Y | 1.32 | 14,200 |
| Z ₁ | 0.89 | 56,000 |
| Z ₂ | 0.89 | Combined magnitude |

With the external power supply current adjusting controls, it is possible to obtain ≤ 0.2 gamma resolution of the field generated by the coils. As indicated by the normal X and Y coil fields, the

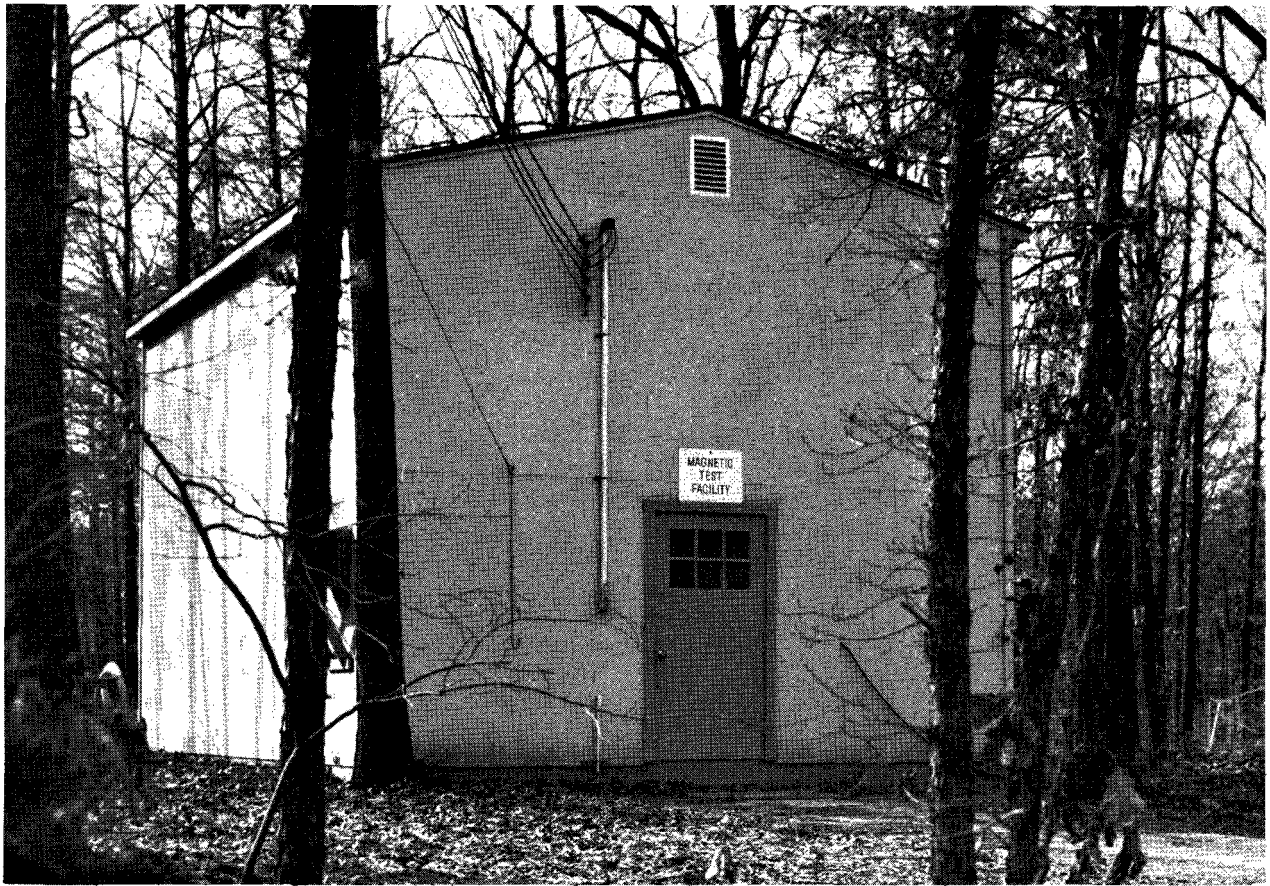

Figure B-1—Component Magnetic Test Facility Building.

Table B-1

Coil System Dimensions and Constants.

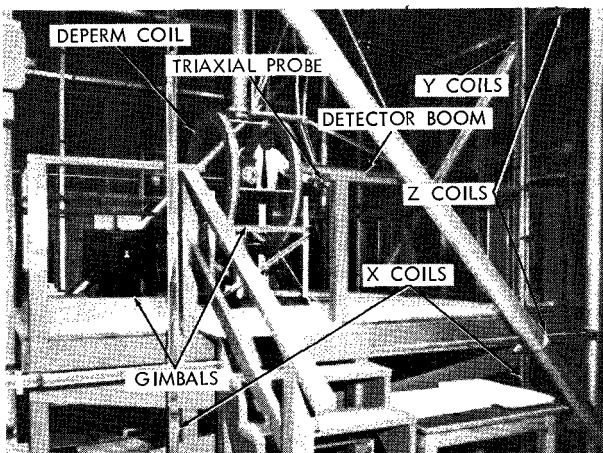

Figure B-2—Component Magnetic Test Facility.

| | X Coil | Y Coil | Z Coil |
|----------------------------------|----------|----------|----------|
| Side length (feet) | 14.0 | 13.7 | 14.3 |
| Separation (feet) | 8.4 | 8.4 | 8.4 |
| Number of turns per loop | 30 | 30 | 175 |
| Total number of turns | 60 | 60 | 350 |
| Coil resistance (ohms) | 35 | 35 | 130 |
| Coil constant (gamma/amp) | 10,785 | 10,785 | 62,912 |
| Field cancellation range (gamma) | 0-20,000 | 0-20,000 | 0-60,000 |

building is aligned such that the Y coil has a West magnetic declination of 043° . When the coils are adjusted for zero field operation, the homogeneity for the center of the coil system within a sphere of 1 foot diameter is such that the field varies by less than 50 gamma from the value at the center. The field homogeneity for the system is as follows:

| <u>Spherical Diameter</u> (Feet) | <u>Spherical Radius</u> (Inches) | <u>Percentage Homogeneity</u> |
|-------------------------------------|-------------------------------------|-------------------------------|
| 1 | 6 | 0.12 |
| 2 | 12 | 0.31 |
| 3 | 18 | 0.66 |

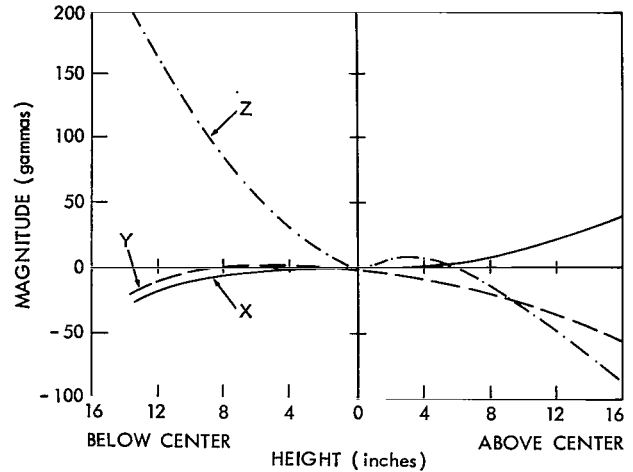

Figure B-3—Zero field - Z coil axis.

The field change (gamma) with distance (inches) along each coil axis (3 component data) is shown in the enclosed graphs (Figures B-3, B-4, and B-5). Due to the structural limitations of the facility, the vertical axis measurements were possible only for a distance of 14 inches above and below the center of the coil system. Additional X and Y coil axis data indicate that a gradient of less than 200 gamma/foot is maintained within a one and one-half foot radius of the center of the coils (Figures B-6 and B-7).

Perm-Deperm Coil

The coil used for the 25 gauss exposure field and the 50 gauss deperming field consists of a single axis circular Helmholtz coil pair (Figure B-2). The physical dimensions and coil constant of the coil are shown in Table B-2.

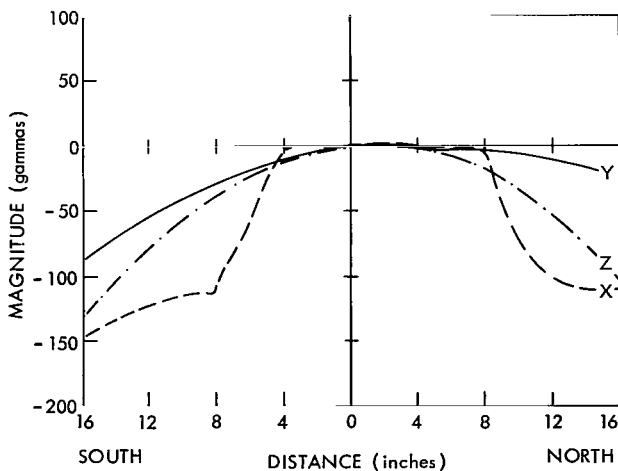

Figure B-4—Zero field - Y coil axis.

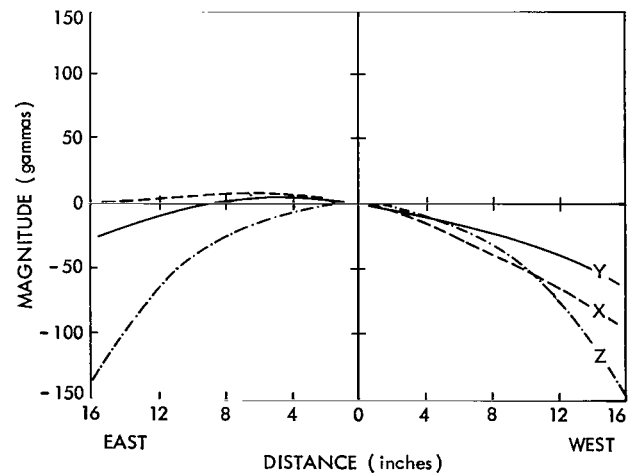

Figure B-5—Zero field - X coil axis.

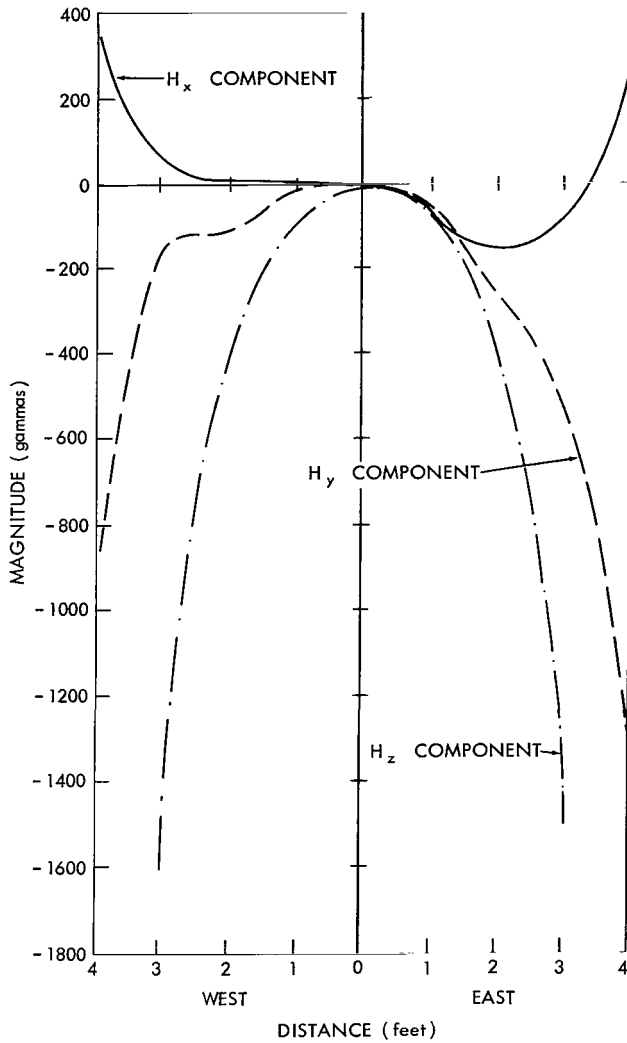

Figure B-6— H_x horizontal axis gradient zero field.

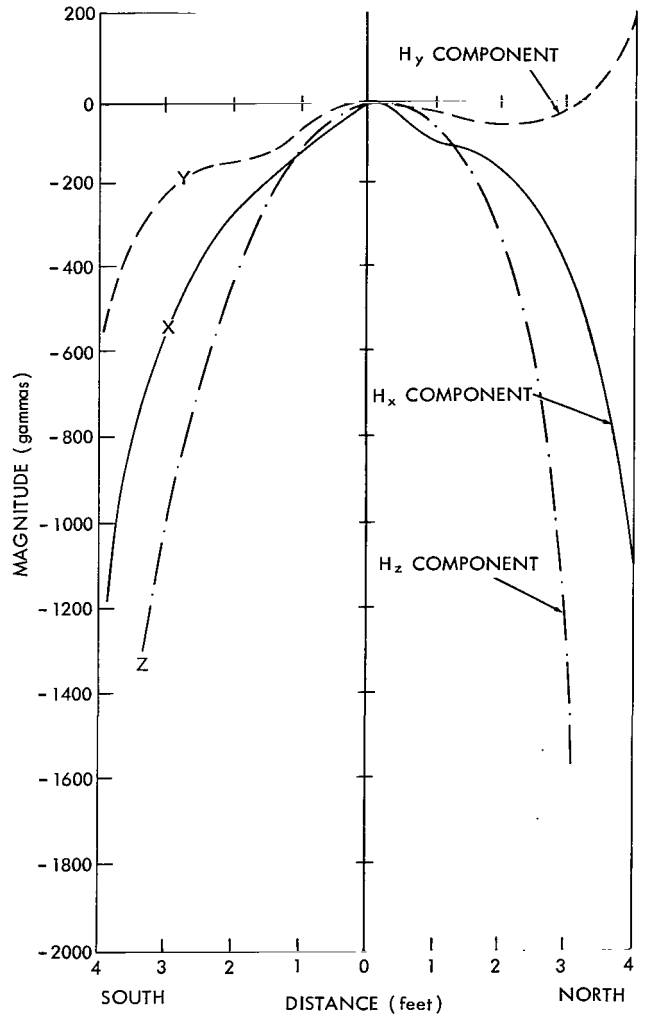

Figure B-7— H_y horizontal axis gradient zero field.

Table B-2

Deperm Coil Data.

| | |
|----------------------------|--------|
| Radius (inches) | 22.81 |
| Separation (inches) | 23.00 |
| Number of turns per loop | 676 |
| Coil resistance (ohms) | 14 |
| Coil constant (gauss lamp) | 5.2197 |

The coil is wired in parallel and is constructed so that the two coil frames can be removed from their position in the center of the coil system when required.

Equipment

All the equipment for the operation of the facility is housed in the control console (Figure B-8). Associated with this equipment are the fixtures utilized in the measurements of components. These fixtures, all non-magnetic, are

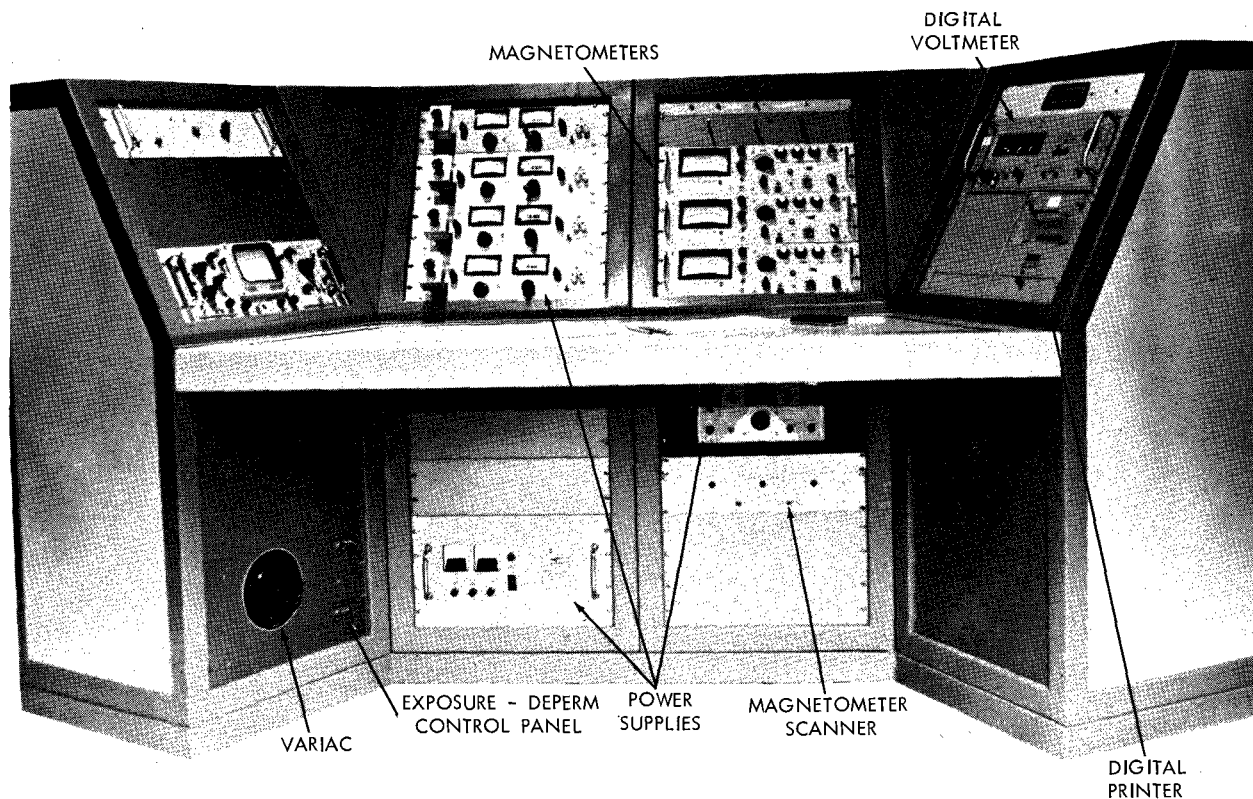

Figure B-8—Control console.

located within the confines of the coil system (Figure B-2). The following list itemizes the equipment employed in the facility:

- 4 - Princeton Applied Research, Model TC-602R - Power Supplies
- 1 - Trygon Electronics Inc., Model C160-160 - Power Supply
- 1 - Electro Products Laboratory, Model EF - Power Supply
- 1 - Variac Autotransformer, Model W50MM - Power Supply
- 3 - Forster-Hoover, Model MF-5050 - Magnetometers
- 1 - Forster-Hoover, Model MF-T-165 - Triaxial Probe
- 1 - Hewlett-Packard, Digital Model 560A - Printer
- 1 - Hewlett-Packard, Digital Model 405CR - Voltmeter
- 1 - GSFC Fabricated - Magnetometer Scanner
- 2 - GSFC Fabricated - Gimbal Fixtures
- 1 - GSFC Fabricated - Detector Boom Assembly with Probe Holder

B-2 Naval Ordnance Laboratory
Magnetic Test Facility - Building 206

Introduction

The Magnetic Ship Model Laboratory - Building 206 which is located at the U. S. Naval Ordnance Laboratory, White Oak, Maryland is primarily a facility for the study of magnetic ship models; however, due to its unique features; i.e., size, equipment, and fixtures, it has served adequately

as a zero magnetic field test facility for the IMP and other spacecraft magnetic field measurements. The mechanical translating carriage system permits the movement of one or more detectors for the purpose of obtaining magnetic field full-off data. In the case of the IMP spacecraft, the spacecraft itself was moved while the fixed detectors monitored the spacecraft field. Figure B-9, is a sketch which shows the facility and its associated equipment.

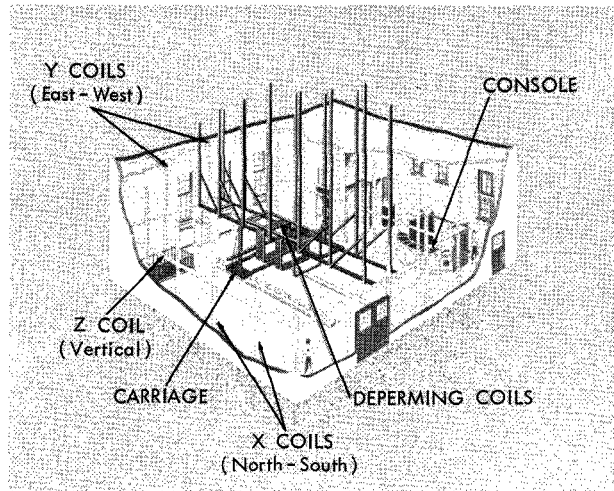

Figure B-9--Naval Ordnance Laboratory - Magnetic Test Facility, Building 206.

Facility Description

A. Building

The building which houses the coil system and associated equipment is constructed of cinder block, concrete,

wood, copper nails and brass bolts in order to avoid the use of ferrous materials. In addition such items as service wiring and plumbing were constructed of nonmagnetic materials. To avoid outside interference the building is located in an isolated area which has been specifically established for magnetic work.

B. Coil System

The facility coil system consists of three mutually perpendicular series of cable loops, held in place by wooden cable carriers, which are mounted on the inner surfaces of the coil room. The coils are constructed of special 37 conductor AWG #14 cables. Table B-3, indicates the coil constants and dimensions.

When the coils are energized to compensate earth's field (zero field) the normal currents and field magnitudes used are as follows:

| <u>Coil</u> | <u>Current (amps)</u> | <u>Field (gamma)</u> |
|-------------|-----------------------|----------------------|
| X | 1.30 | 17,450 |
| Y | 0.01 | 30 |
| Z | 2.40 | 53,690 |

Table B-3

Coil System Dimensions and Constants.

| | X Coil | | Y Coil | Z Coil | |
|---|------------------------|-----------------------------|----------------|------------------------|-----------------------------|
| | Main X ₁ | Auxiliary X ₂ | Y ₁ | Main Z ₁ | Auxiliary Z ₂ |
| Dimensions (feet) | | | | | |
| North-South | 36.3 | 36.3 | 37.9 | 37.1 | 37.1 |
| East-West | 29.1 | 29.1 | 30.3 | 29.7 | 29.7 |
| Height | 29.1 | 29.1 | 30.3 | 29.7 | 29.7 |
| Spacing (feet) | 7.3 | 7.3 | 7.6 | 7.4 | 7.4 |
| Number of Loops per coil | 6 | 6 | 5 | 5 | 5 |
| Number of Cable Turns per Loop | | | | | |
| Outer | 2 | 2 | 2 | 3 | 2 |
| Middle | 2 | * | 1 | 2 | * |
| Center | 2 | * | 1 | 3 | * |
| Number of conductors per Turn per Loop | | | | | |
| Outer | 31 | 31 | 33 | 37 | 37 |
| Middle | 10 | 10 | 18 | 15, 16 | 16, 15 |
| Center | 14 | 14 | 27 | 18, 10, 18 | 18, 10, 18 |
| Total No. of Conductors | 220 | 220 | 195 | 330 | 330 |
| Coil Resistance (ohms) | 300 | 300 | 370 | 300 | 300 |
| Coil Constant (gamma/amp) | 14,190 | 14,190 | 12,870 | 22,370 | 22,370 |
| Field Cancellation range (gamma) (4 amps limit) | 0-56,760 | 0-56,760 | 0-51,480 | 0-89,480 | 0-89,480 |

*Shares conductors with main coil.

The geomagnetic field can be nulled to zero within 0.1% uniformity throughout a volume at the center of the coil of 6' x 6' x 12'. Since the center of the coil system is approximately 7 feet above the main floor and is occupied by rails and fixtures used for ship model testing, the spacecraft is not normally placed in the center of the coils except during the exposure and deperm treatment. A gradient survey was conducted throughout the normal zero field region in which the spacecraft is placed. Figures B-10, B-11, and B-12 show the H_x, H_y, and H_z component gradients for the X, Y, and Z coil axes for a center point which is 38-3/4" below the center of the coil system. The zero field homogeneity for the test volume is as follows:

| Spherical Diameter (feet) | Spherical Radius (inches) | Percentage Homogeneity |
|---------------------------|---------------------------|------------------------|
| 1 | 6 | 0.02 |
| 2 | 12 | 0.04 |
| 3 | 18 | 0.06 |
| 4 | 24 | 0.08 |
| 6 | 36 | 0.14 |

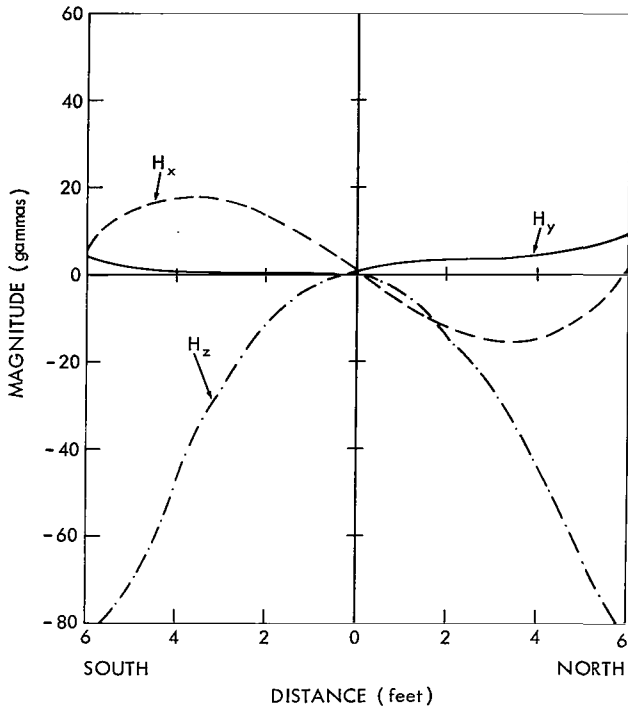

Figure B-10—Zero field - X coil axis.

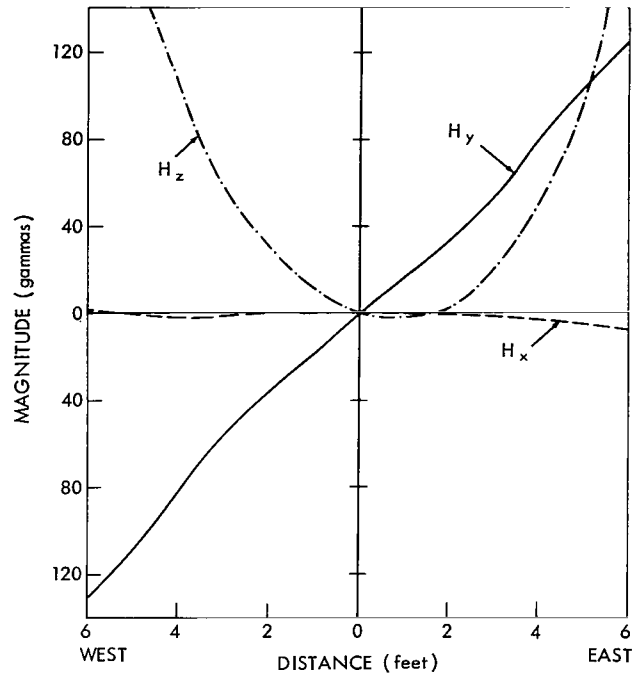

Figure B-11—Zero field - Y coil axis.

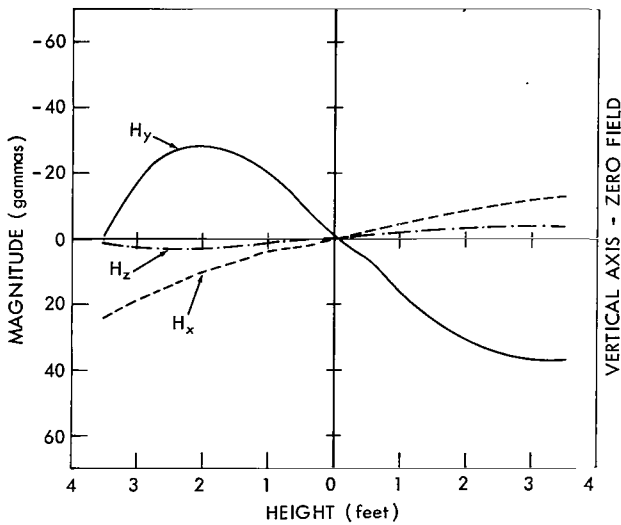

Figure B-12—Zero field - Z coil axis.

C. Perming and Deperming Coil

Overhead mounted coils consisting of 14 square wood frames (36" × 36") which during use are normally spaced 1 foot apart except for the two end frames and contain 25 turns each of No. 6 round magnet wire. The coils are hung so that the solenoid axis is parallel with the North-South coil axis. When not in use the frames can be pushed back in each direction and also raised by a hoist to an overhead position which allows suitable clearance for entering into the coil system. The coils are normally used for deperming (ac) and have a 50 gauss field capability; however, an external dc supply can be hooked to the coils when required for exposure tests.

D. Automatic Translator

A longitudinal carriage 13' × 4' × 1/2' which moves along rails in the North-South direction contains an east-west oriented horizontal "I" beam upon which detectors are mounted.

This detector boom can be raised or lowered in height a distance of approximately four feet. With this carriage it is possible to obtain translatory "fall-off" data by the following two means:

1. Detector motion with spacecraft stationary.
2. Spacecraft motion with detector stationary.

The longitudinal carriage is driven by a variable speed power system through a 27 ft K-monel shaft and silicon bronze roller chains. The drive controls are located in the console. The power system, which consists of a 1/2 hp dc motor and gear reducer, is located in the basement room annex outside the field area.

E. Master control console

The Master control console contains all the controls necessary for the operation of all the equipment in the facility. It is basically a 10 ft. diameter wood and brass cabinet (Figure B-9) within the console are the following controls and equipment.

- 10 - Magnaflux FM 204 Magnetometers
- 3 - NJE Corp QR-36-4 power supplies
- 1 - Huston Instrument Corp HR-97 X-Y plotter
- 1 - Dymec 2401A integrating digital voltmeter
- 1 - AC Deperming Shaker Circuit
- 1 - Carriage and Deperm Coil hoist motion and speed control.



Appendix C

Test Procedure

C-1. IMP-I Components Magnetic Test Procedure

Introduction

Magnetic field measurements are performed on the IMP spacecraft components in order to obtain design control data. The measurements are performed at the beginning (initial test) and conclusion (final test) of the environmental test sequence. The initial test consists of measurements of the permanent (initial, post exposure, and post deperm) induced 0.26 gauss applied field, and stray field magnetization of the component as specified in the IMP Environmental Test Specification for Components GSFC-S-320-IMP-I, paragraph 4-2, which are as follows:

4.2 PRE-TEST MAGNETIC FIELD MEASUREMENT.

Magnetic Field Measurements shall be taken at 18 to 36 inches. The requirements shown in Table II shall be applicable to components undergoing both Design Qualification and Flight Acceptance measurements.

Table II
Initial Magnetic Field Measurement.*

| Condition | Applied Field (gauss) | Magnetic Field Disturbance (gamma) | |
|---------------------------------------|-----------------------|------------------------------------|---------------------|
| | | 18 inches** Max.*** | 36 inches** Max. |
| (1) Perm - Initial | 0 | 8 | 1 |
| Post 25 - gauss exposure | 0 | 32 | 4 |
| Post 50 - gauss Deperm | 0 | 2 | 0.25 |
| (2) Induced | 0.26 | 2 | 0.25 |
| (3) Stray - power "on" vs power "off" | 0 | 4 | 0.50 |

*Design goal for the integrated spacecraft is that the total magnetic field disturbance for all sources aboard the spacecraft shall not exceed 1/2 gamma measured at the magnetometer sensors in their final extended positions.

**Measured from Geometric Center of component.

***If the Magnetic Field Disturbance measurement at 18 inches is 10 gamma or less the magnitude at 36 inches may be computed using the inverse distance cubed relationship. For large packages, which preclude measurements at 18 inches, measurements shall be made at 36 inches and 48 inches, to determine the rate at which the magnetic field diminishes with distance.

The final test is then performed at the conclusion of the environmental test sequence as specified in paragraph 4.9 which is listed below.

4.9 FINAL MAGNETIC FIELD MEASUREMENT

Magnetic Field Measurements shall be taken at 18 and 36 inches. The requirements shown in Table XVII shall be applicable to all components and are also applicable for both Design Qualification and Flight Acceptance measurements.

Table XVII

Post-Test Magnetic Field Measurement.

| Condition | Applied Field (gauss) | Magnetic Field Disturbance* (gamma)* | |
|-----------|-----------------------|--------------------------------------|-------------|
| | | 18 inches** | 36 inches** |
| Perm | 0 | 2 | 0.25 |

*The measured magnetic field disturbance for any component shall not exceed the value measured in 4.2 Table II condition (1).

**Measured from geometric center of component.

The IMP components are measured in accordance with these specifications by following the detailed Magnetic Test Procedure.

INITIAL TEST

A. Initial Perm

1. With the component in zero field and the detector 18 inches from the geometric center of the component, measure the maximum positive and negative radial component by following the radial component magnitude determinations procedure listed in step 2 below.
2. Radial Component Magnitude Determinations
 - a. With the test assembly in the gimbal, rotate the gimbal in zenith and azimuth in order to locate the maximum radial component (plus peak), recheck with additional zenith and azimuth rotation. Then record the gimbal azimuth and zenith angles for the peak.
 - b. First, record the peak magnitude (angle), return the gimbal to the zero reference position (0), and then record the zero reference magnitude.
 - c. Repeat step b and then check the difference between the peak and zero magnitudes. If these values agree within 0.3 gamma continue to step d; if not, repeat step b.
 - d. Next, rotate the gimbal and locate the minus peak. Record these angles. Note: When the azimuth angle of rotation exceeds 180° use a 180° rotation in zenith instead.

- e. Repeat the measurement steps b and c in order to determine the magnitude of the minus peak.
- f. Unclamp the gimbal to release the assembly.
- g. With the assembly in the zero reference position, record the magnitude (assembly-in), then remove the assembly and record the background (assembly-out) magnitude.
- h. Repeat step g in order to obtain 0.3 gamma agreement.
- i. Once the magnitude of the assembly is known for the zero reference position (difference between out-and-in), the magnitude, when added to the mean difference between the zero position and the peak position determines the actual peak magnitude.
- j. The magnitude reported is the maximum (positive or negative) magnitude which was measured.
- k. Example 1 - Positive Reference Magnitudes

| | <u>Positive Peak</u> | | <u>Negative Peak</u> | |
|-----------------------|----------------------|------------|----------------------|------------|
| Peak (angle) | 4.5 | 4.7 | -4.2 | -4.2 |
| Reference (o) | <u>1.3</u> | <u>1.3</u> | <u>1.3</u> | <u>1.3</u> |
| Difference | +3.2 | +3.4 | -5.5 | -5.5 |
| Mean | +3.3 | | -5.5 | |
| Assembly in | | 1.3 | 1.1 | |
| Assembly out | | <u>0.2</u> | <u>-0.2</u> | |
| in vs out | | +1.1 | +1.3 | |
| Mean | | | +1.2 | |
| Actual peak magnitude | +1.2 | | +1.2 | |
| | <u>+3.3</u> | | <u>-5.5</u> | |
| | +4.5 | | -4.3 | |

Example 2 - Negative Reference Magnitudes

| | <u>Positive Peak</u> | | <u>Negative Peak</u> | |
|-----------------------|----------------------|-------------|----------------------|-------------|
| Peak (angle) | 5.2 | 4.9 | -4.5 | -4.7 |
| Reference (o) | <u>-3.5</u> | <u>-3.7</u> | <u>-3.2</u> | <u>-3.1</u> |
| Difference | +8.7 | +8.6 | -1.3 | -1.6 |
| Mean | +8.7 | | -1.4 | |
| Assembly in | | -3.1 | -3.3 | |
| Assembly out | | <u>0.5</u> | <u>0.7</u> | |
| in vs out | | -3.6 | -4.0 | |
| Mean | | | -3.8 | |
| Actual peak magnitude | -3.8 | | -3.8 | |
| | <u>+8.7</u> | | <u>-1.4</u> | |
| | +4.9 | | -5.2 | |

3. Record the measured data on the data sheet. If the magnetic field disturbance of the component exceeds 10 gamma, remeasure the component at 36 inches.
4. Before the measurement probe is moved, check the zero field for drift, adjusting if necessary, then move the probe to the second distance. Readjust the step compensation switches as required in order to rezero the magnetometers.
5. Measure the maximum radial component (step 1).
6. Return the probe to the initial measurement position (18 inches) and readjust the zero field compensation (reverse procedure of step 4).

B. Induced

1. With all the magnetometer sensitivity switches on zero, reverse the Y coil (field changed from compensating to aiding earth's field) by throwing the Y coil reversing switch from cancel to double. (Effective applied field 0.26 gauss).
2. Make a note of the position of the magnetometer compensation control settings (Y axis magnetometer electronics). Return this magnetometer to the one scale by adjusting the step compensators as needed.

Note: Do not change the fine adjust compensating potentiometer.

3. Measure the maximum (plus and minus) radial components at the angles previously determined from initial perm measurements of paragraph A by following the radial component measurement procedure (paragraph A step 2).
4. Since these measurements are induced plus permanent magnetization, algebraically subtract the permanent magnetization, values obtained in paragraph A, from the induced plus perm magnitudes just obtained. These magnitudes represent the induced magnetization of the assembly for an applied field of 0.26 gauss.
5. Record the induced data on the data sheet. If the field exceeds 10 gamma, then second distance (36 inches) measurements are to be performed.
6. When second distance measurements are made, move the probe to the second distance and then adjust the magnetometer compensation as needed.
7. Measure the maximum radial component (repeat steps 3, 4, and 5).
8. Return the probe to the initial measurement position, with the magnetometer range selector switch in the zero position, return the "Y" coil current reversing switch to cancel and the compensators to their original positions.
9. When the maximum induced plus permanent radial component has a direction other than that of the maximum permanent radial component, it will be necessary to determine the initial

permanent radial component magnitude for this direction in order to compute the maximum induced magnetization.

C. 25 Gauss Exposure

1. In order to expose the component to the 25 gauss field, determine the location and polarity of the permanent magnetic moment of the component by referring to the angles and magnitudes recorded in paragraph A.
2. With the component in the gimbal, align the moment along the axis of the exposure coils so that both fields are in the same direction.
3. Turn all the magnetometers to the zero position, then with the coils connected to the dc power supply, apply 5 amps of current to the coils—normal exposure time at least 3 seconds—.
4. Turn the current off and break the circuit. Turn the magnetometers to the appropriate sensitivity scale for measuring the magnitude of the component. Check the component to see if the direction of the peak has shifted. If the peak has shifted more than 10 degrees then repeat the 25 gauss exposure (step 6) on the new peak.
5. With the component in zero field, measure the maximum radial component following the procedure in paragraph A.
6. Record the measured data on the data sheet. If the post 25 gauss exposure magnitude at 18 inches exceeds 10 gamma remeasure the component at 36 inches.

D. Deperm

1. With the component removed from the gimbal, rezero the field. Replace the component in the gimbal and then clamp the component in the gimbal.
2. With the component turned to the maximum exposure angle (paragraph C-2) and the magnetometers turned to the zero position, apply 10 amperes of 60 cycle ac current to the Helmholtz perming coils. Decrease this current slowly to zero.
3. Turn the magnetometers to the one scale and locate the direction of the maximum radial component.
4. If the direction of the maximum radial component has shifted and, or, its magnitude is not below 95% of the maximum post exposure magnitude, repeat step 2 in the new direction or on the peak radial component.
5. When it is not possible to deperm the assembly below 95% of the post exposure magnitude, ascertain if the component contains parts with permanent magnets such as relays which would not deperm in the 50 gauss field.

6. Measure the maximum radial component following the procedure in paragraph A, step 2.
7. Record the measured data on the data sheet. If the magnitude at 18 inches exceeds 10 gamma remeasure the component at 36 inches.

E. Stray

1. With the probe located at the measurement distance (18 inches) connect the power cables to the component and then clamp the component in the gimbal.
2. After the experimenter or his representative has determined that the component is operating and the voltage and current adjustments have been completed, the stray field measurements can be made.
3. Record the operational voltage and current magnitudes for the component.
4. The stray field measurements are then made by recording the field magnitude with the component operating and with the component non-operative (power-on vs power-off).
5. Obtain information from the experimenter as to possible current changes which would occur while the component is functioning, i.e., calibration, step functions, stand-by or transmit conditions. In the event several such modes of operation occur, record the maximum stray field magnitude condition.
6. Measure the stray field (radial component) along each face of the component (+X, -X, +Y, -Y, +Z, -Z).
7. Select the component face which has the highest magnitude then shift the gimbal in azimuth and zenith to locate the peak stray field magnitude and direction.
8. When the magnitude at 18 inches exceeds 10 gamma, second distance measurements (18 inches) of the maximum radial component of the stray field are to be performed.

FINAL TEST

A. Permanent Magnetization

1. With the component in zero field, and the detector 18 inches from the geometric center of the package, measure the maximum positive and negative radial component by following the radial component magnitude determinations procedure in the initial test procedure—paragraph A, step 2.
2. Record the measured data on the data sheet. If the magnetic field disturbance of the component exceeds 10 gamma, remeasure the component at 36 inches.

B. Deperm

1. Deperm the component as outlined in the initial test procedure paragraph D, steps 1-5.
2. Measure the remanent magnetic field disturbance of the component (initial test procedure paragraph D steps 6 and 7).

ANALYSIS AND REDUCTION TESTS

In the event that a component or components have magnetic field disturbance magnitudes which exceed the design goal values, further (Analysis and Reduction) tests are then performed. These tests are utilized in order to determine the possible sources of magnetic field disturbance and means by which these magnitudes can be reduced. Since these tests vary with the component and the associated type of magnetic field disturbance problem (perm and/or stray), no one particular test procedure is followed; however, as a guide refer to the initial test procedure.

C-2 IMP-I Spacecraft Magnetic Test Procedure - NOL Facility

- I. Facility Operational Procedure
- II. Spacecraft Test Arrangement
- III. Spacecraft Test Procedure
- IV. Deperm Measurements
- V. Initial Test Measurements
- VI. Post Environmental Exposure Measurements
- VII. Final Test Measurements

I. FACILITY OPERATIONAL PROCEDURE

A. Equipment

Bldg. 206 Coil Facility

- 3 - Fluxgate Magnetometers MAGNAFLUX FM 204
- 3 - Tripole Detectors (X, Y, and Z probes)
- 3 - Power Supplies (Magnetically regulated) NJE Corp. Model QR-36-4
- 1 - Y-Y Plotter Huston Instrument Corp. Model HR-97
- 2 - Strip Chart Recorders - Mosley Model 681
- 1 - Integrating Digital Voltmeter (Current Measuring) Dymec Model 2401A
- 1 - Vertical Gimbal Fixture
- 1 - Horizontal Fixture
- 1 - AC Deperming Shaker Circuit (50 Gauss Capacity)

B. Equipment Operation

1. With the spacecraft removed from the facility, turn on all equipment listed in paragraph A excluding deperming and perming coils.
2. After at least 30 minutes warm-up, set zero field

| Coil - Direction | Approximate Settings |
|------------------|------------------------|
| X Coil - South | 389.53 volts 1.30 Amps |
| Y Coil - East | 3.71 volts 10 MA |
| Z Coil - Up | 708.39 volts 2.40 Amps |

C. Magnetometer Adjustments

1. After the detectors have been positioned (Section II), the magnetometers are then adjusted.
2. Connect the three tripoles to the respective magnetometers which are to be used.
3. With the coil system operating - zero field - compensate the magnetometers to zero and then calibrate the magnetometers and the recorders.

II. SPACECRAFT TEST ARRANGEMENT

A. Vertical (Spin Axis) Detector at Rb Magnetometer Flight Position.

1. Remove overhead carriage and release pull cables.
2. Place detector #9 overhead and mount on top of the deperming coil hoist rails. Align the detector so that the center lines of the three probes are aligned with the vertical center line coil axis. Adjust the height of the detector by raising or lowering the depermm coils so that the vertical sensing probe (H_z) will be 72 inches from the center of the spacecraft (middle of facets). Figure C-1 indicates the spacecraft test arrangement.

B. Tripod (Horizontal Axis) Detector at Fluxgate Sensor Flight Position

1. Mount a second detector on an adjustable tripod, align the X, Y, and Z probes so that their axes correspond with the coil system axes. X (North-South), Y (East-West) and, Z (Vertical).
2. Position the X probe so that it is 84 inches North of the center of the coil system.
3. Adjust the height of the tripole so that its center will be 10-1/4 inches below the center of the spacecraft (fluxgate sensor flight position).
4. Mark the tripod leg positions.

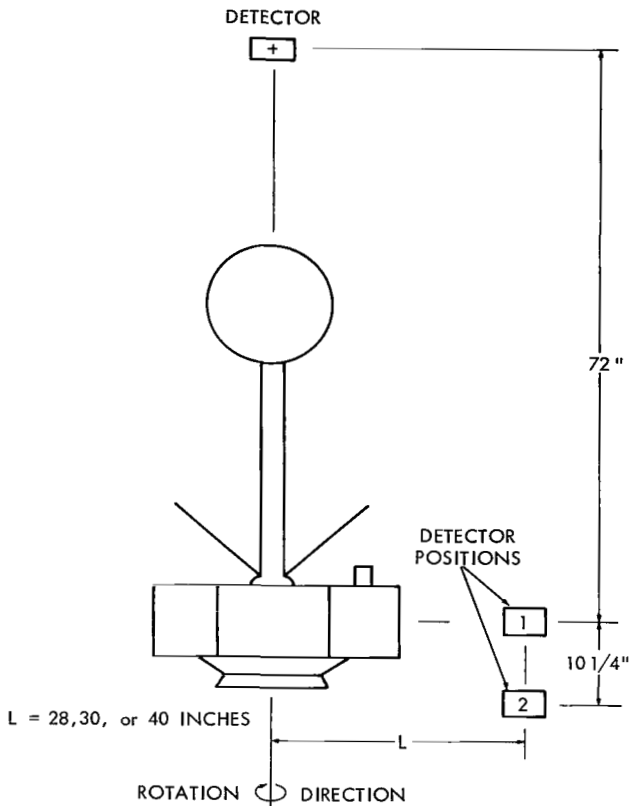

Figure C-1—Test arrangement for vertical spin axis rotation of spacecraft.

2. Adjust the height of the detector until it will be at the spacecraft mid-height position.
3. Move the carriage until the E-W sensor is 28 inches North of the center of the coils.

D. Spacecraft Gimbal Fixture

1. Select the vertical rotational spindle and place it in the center of the coil system.

E. Carriage Fixture

1. Place the large mounting plate on the carriage and attach the spacecraft adapter ring to the plate. Center this fixture on the carriage so that the spacecraft (when mounted) will be centered in the coil system along the East-West axis.
2. Extend the East-West center line in the East side of the carriage and position a center line pointer on the side of the carriage (used for North-South distance measurements). Figure C-2 indicates the carriage test arrangement.

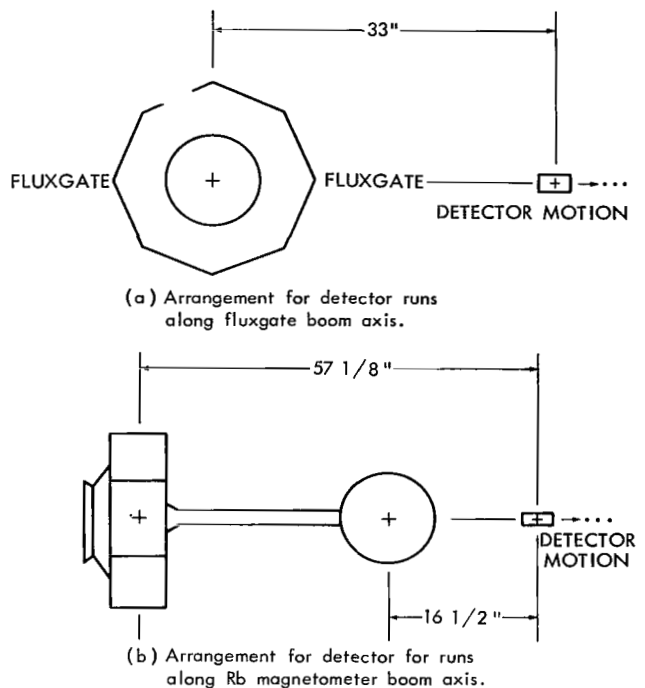

Figure C-2—Test arrangement for fall-off with distance along spin and boom axis.

C. Carriage (Mid-Height) Detector

1. Position the third tripole (#5) on the carriage detector beam and align in the center of the system.

3. Step up the tripod detector so that it is centered along the X coil axis (North-South) and 60 inches North of the center of the coils.
4. Mark the position of the tripod legs.
5. With the tripod as zero and moving south, mark the even foot distances along the carriage track (from 3 to 7 feet) including a center of the coils mark.
6. Adjust the height of the vertical detector to 72 inches.

III. SPACECRAFT TEST PROCEDURE

A. Spacecraft Rotational Data

1. Connect the X-Y plotter to the carriage (#5) detector magnetometer and set the magnetometer selector switch on the X component position. Switch in the X compensator and compensate the magnetometer to zero.
2. Rotate the spacecraft 360 degrees while operating the X-Y plotter.
3. Adjust the recording speed so that two complete rotations of the spacecraft can be recorded on the graph paper.
4. Select the proper sensitivity range. Whenever possible use the 1 range (2 gamma per division sensitivity).
5. Connect the brush recorder to the vertical and tripod detector magnetometers. Select the X component and center the recording pens with the magnetometer compensation networks (normal adjustment of magnetometers for zero).
6. First start the recorders and then rotate the spacecraft (vertical rotational spindle) two complete revolutions while indexing each 45 degree increment of rotation with the recorder event markers.
7. Select the next component or adjust the position of the detectors as required and then repeat the rotational data procedure (steps 1-6).

B. Spacecraft Fall-Off Data - Spacecraft Motion

1. Set up the tripod detector at the fall-off data position (60 inches north of the coil center).
2. Mount the spacecraft on the carriage.
3. Rotate the spacecraft to the reference position.
4. Clamp the spacecraft to the fixture.

5. Connect the X-Y plotter to the tripod detector magnetometer, selecting the X component.
6. Run the carriage North until the spacecraft is 28 inches south of the center of the tripod detector (start position).
7. With the X-Y recorder and the spin axis recorder operating, translate the carriage south indexing the even foot distances plus the center position.
8. At the 7 foot distance stop the carriage and the recorders, select the next component. Note the field change as the spacecraft is returned to the zero position. Stop the carriage and then select the proper sensitivity range for recording.

C. Spacecraft Fall-Off Data - Detector Motion

1. Mount the spacecraft on the vertical or horizontal spindle fixture, Figure C-2 indicates the spacecraft and detector test arrangement.
2. Adjust the height of the carriage detector for the proper measurement height.
3. Rotate the spacecraft to the reference position.
4. Run the carriage south to the start position.
5. With the X-Y recorder operating (X component) translate the carriage North indexing the even foot distances.
6. Stop at the end position and return the carriage to the start position repeat step 5 if necessary.

D. Exposure and Deperming - Horizontal Axis

1. With the spacecraft on the vertical rotational fixture, extend the fixture by raising the spacecraft into the deperming coils. Lock the fixture except for the upper spindle.
2. Slide the frames together adjusting for normal coil spacing and then center, vertically, on the mid-height of the spacecraft. Figure C-3 indicates the test arrangement.
3. Apply the exposure field (25 gauss dc) coil constant 1 gauss 1 amp or deperming field (50 gauss ac). Slowly rotate the spacecraft. Exposure time - 15 seconds.
4. Remove the exposure field or in the case of the deperming field, rotate the spacecraft as the field is diminished to zero.
5. Slide back the coil frames and then lower the spacecraft on the spindle.

E. Exposure and Deperming - Spin Axis (Figure C-3)

1. Attach the horizontal mounting fixture to the upper railing.

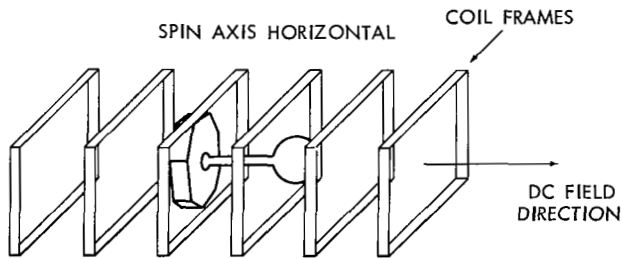
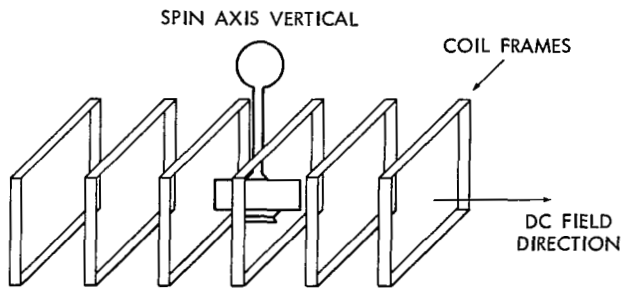

Figure C-3—Test arrangement for exposure and deperming of spacecraft.

2. Mount the spacecraft on the fixture.
3. Slide the deperming coil frames together and center the spacecraft.
4. Apply the exposure (25 gauss) or deperming field (50 gauss).
5. At the conclusion of the exposure or deperming sequence, remove the spacecraft.

IV. DEPERM TEST MEASUREMENTS

A. Initial Permanent Magnetization

1. With the mid-height detector at 28 inches, record X, Y, and Z component rotational data (Section III A).
2. Repeat step 1 with detector at 40 inches.

3. With the spacecraft in the center of the coil system and mounted on the vertical spindle fixture, obtain mid-height radial component fall-off data. Start with detector at 25.8 inches then move the carriage north to 60 inches.

B. Deperm

1. Deperm spacecraft in a 50 gauss ac deperm field (Section III E).
2. Repeat the initial permanent magnetization measurement sequence (step 1).
3. With spacecraft on horizontal spindle fixture measure radial component fall-off along spin axis - 54.4 to 110 inches (Section III C).
4. Deperm spacecraft (Section III D).
5. Repeat step 2.
6. Repeat step 5 with detector at 40 inches.

V. INITIAL TEST MEASUREMENTS

A. Initial Permanent Magnetization

1. With the mid-height detector at 30 inches, and the 20 inches above and below mid-height detectors at 20 inches, record X, Y, and Z component rotational data (Section III A).

B. 25 Gauss Exposure

1. Expose the spacecraft (Section III D and E).
2. Repeat the initial permanent magnetization measurement sequence (Paragraph A).

C. Deperm

1. Deperm spacecraft (Section III D and E).
2. Repeat the initial permanent magnetization measurement sequence (Paragraph A).

D. 25 Gauss Exposure

1. Re-expose the spacecraft (Section III D and E).
2. Measure X, Y, and Z component fall-off with distance along fluxgate "A" boom axis. Start detector at 33 inches and stop at 90 inches (Section III C).
3. Repeat step 2 and measure fall-off along fluxgate "B" boom axis.
4. Measure X, Y, and Z component fall-off along spin axis - 57.2 to 104 inches (Section III C).
5. Measure X, Y, and Z component fall-off along fluxgate "A" boom axis. Detector at 40 inches and spacecraft then moved outward to 150 inches. (Section III B).
6. Repeat step 5 and measure fall-off along fluxgate "B" boom axis.
7. Deperm the spacecraft.

E. Stray Field Magnetization

1. Measure X, Y, and Z component stray field for the following positions and distances:

| | |
|-----------------|---------------------------|
| Spin axis | 74 inches |
| Fluxgate A axis | 30, 40, 50, and 60 inches |
| Fluxgate B axis | 30, 40, 50, and 60 inches |

2. With detector 30 inches from spacecraft and at fluxgate height, measure 3 component rotational data (Section III A).
3. With spacecraft on horizontal spindle fixture and large turntable, measure X, Y, and Z component rotational data with detector at 40.8 inches.

VI. POST ENVIRONMENTAL EXPOSURE MEASUREMENTS

1. Measure X, Y, and Z component fall-off data (Initial test measurements, Section V, D, steps 5 and 6). Place second detector overhead to obtain spin axis fall-off data.

VII. FINAL TEST MEASUREMENTS

A. Initial Permanent Magnetization

1. Obtain mid-height radial component rotational data (Section III A) with detector at 25.8 inches.
2. Repeat step 1 with detector at fluxgate height.

B. Deperm

1. Deperm spacecraft (Section III D and E).
2. Repeat initial permanent magnetization measurements, steps 1 and 2, Paragraph A.

Appendix D

Test Activity Log

D-1 Components Magnetic Test Log

| <u>Date</u> | <u>Item</u> | <u>Test & Remarks</u> |
|-------------|---------------------------|---|
| 8-12-62 | Chicago Magnesium Samples | Perm Check |
| 12-18-62 | Proton Analyzer | Initial Perm |
| 2-11-63 | Performance Parameter | Initial Stray |
| 3-7-63 | Dumping Circuit Resistor | Stray |
| 3-21-63 | Battery | Initial Stray Check |
| 3-22-63 | Prime Converter | Initial Perm & Stray |
| 3-23-63 | E vs dE/dx Units | Initial Perm & Stray |
| 3-27-63 | Battery | Stray Analysis & Reduction |
| 4-1-63 | Ion Chamber | Initial Perm |
| 4-1-63 | Wiring Harness | Perm Check |
| 4-3-63 | Ion Chamber Parts | Perm Analysis & Reduction |
| 4-18-63 | Proton Analyzer | Perm Reduction Check |
| 4-19-63 | E vs dE/dx Power Supply | Stray Analysis & Reduction |
| 5-4-63 | Performance Parameter | Stray Analysis & Reduction |
| 5-7-63 | R vs dE/dx Photo Tube | Perm Analysis & Reduction |
| 5-15-63 | Ion Chamber | Perm Reduction Check |
| 5-16 to | | |
| 6-11-63 | Facet C Tests | Deperm & Vibration |
| 5-17-63 | Prime Converter | Stray Analysis & Reduction |
| 5-21-63 | R vs dE/dx components | Perm Analysis & Reduction |
| 6-18-63 | Deperm | Increased dc Deperm Magnitude to 50 gauss |
| 7-3-63 | E vs dE/dx | Stray Analysis & Reduction |

| <u>Date</u> | <u>Item</u> | <u>Test & Remarks</u> |
|-------------|--------------------|-----------------------------------|
| 7-10-63 | Field Measurements | AMR Background Field Measurements |
| 9-19-63 | Solar Paddle | Initial Perm & Stray |
| 11-22-63 | Deperm | Changed to 50 Gauss ac Deperm |

D-2 Spacecraft Magnetic Test Log

| <u>Date</u> | <u>Item</u> | <u>Remarks</u> |
|-------------|--------------------------------------|-------------------------|
| 7/8-10/63 | AMR Survey | |
| 7/20/63 | Perming of Tools | |
| 8/8/63 | Deperm Test - NOL | Deperm |
| 8/9/63 | Magnetometer Calibration-FMO | |
| 8/12-12/63 | Initial Test - NOL | Full Survey |
| 8/9/63 | Post-Vibration Test - NOL | Perm Check |
| 10/9/63 | Magnetometer Calibration - FMO | |
| 10/24/63 | Final Test - NOL | Final Survey and Deperm |
| 10/23/63 | Final Magnetometer Calibration - FMO | |
| 10/24/63 | Tool Depermer Utilized | |

Appendix E

Components Magnetic Test Data Summary Table



IMP-I Component Magnetic Test Data
Radial Component Magnitude in Gammas at 18 Inches.

| Item | Date | Magnetization | | | | | Test | S/N | Notes |
|-------------------------------|---------|---------------|-------------|-------------|----------------------------|------|-------|----------|-------------------|
| | | Initial Perm | Post Expos. | Post Deperm | Induced Stray (0.26 Gauss) | | | | |
| FACET A | | | | | | | | | |
| O.A. Electronics | 6/14 | 2.0 | 9.8 | 1.0 | 0.6 | - | I | 02 | |
| E vs dE/dx Electronics #1 | 3/23 | 9.6 | 24.2 | 0.9 | 1.6 | 23.8 | I | - | |
| | 6/5 | - | - | - | - | 5.6 | Stray | 01 | |
| E vs dE/dx Electronics #2 | 3/23 | 13.8 | 29.6 | 4.8 | 3.3 | 23.0 | I | 01 | |
| | 6/5 | 16.2 | 38.9 | 2.5 | - | 3.8 | A&R | 01 | |
| E vs dE/dx Sensor | 3/23 | 13.2 | 107 | 3.8 | 2.4 | 0.6 | I | 01 | |
| | 5/7 | 45.8 | 160.4 | 5.2 | - | - | I | 02 | |
| | 9/17 | 10.6 | 134.8 | 0.8 | 8.1 | 0.7 | I | 03 | |
| E vs dE/dx E.E. 1 & 2 | 4/6 | - | - | - | - | 46.6 | Stray | 02 | |
| | 6/5 | - | - | - | - | 6.6 | Stray | 01 | |
| | 6/24 | - | - | - | - | 3.5 | A&R | 02 | |
| | 7/3 | 8.2 | 47.4 | 3.4 | 5.6 | 5.6 | I | 03 | |
| | 7/12,15 | - | - | - | - | 3.6 | A&R | 03 | |
| | 8/13 | - | - | - | - | 1.5 | A&R | 04 | Initial Stray 5.1 |
| E vs dE/dx E.E. 1 & 2, Sensor | 10/24 | 20.0 | - | 4.1 | - | - | I | 04,04,03 | |
| | 10/31 | 19.9 | - | 3.3 | - | - | F | 04,04,03 | |
| FACET B | | | | | | | | | |
| Multi-converter | 3/4 | 3.1 | - | - | - | 1.4 | I | 01 | |
| | 3/30 | 2.1 | 22.3 | 1.3 | 2.5 | 4.0 | I | 02 | |
| | 4/13 | 1.3 | 55.7 | 1.6 | 7.4 | 0.9 | A&R | 02 | |
| | 6/11 | 2.2 | 26.6 | 1.6 | 2.6 | 0.6 | I | 03 | |
| | 10/17 | 2.5 | 26.8 | 0.9 | 2.9 | 0.5 | I | 06 | |
| | 10/24 | 8.6 | - | 1.0 | - | - | F | 06 | |
| Range vs dE/dx #1 | 4/3 | 4.6 | 45.5 | 2.8 | 4.4 | - | I | 02 | |
| | 4/9 | 35.9 | 58.1 | 9.6 | - | - | I | 02 | Exposed to magnet |
| Range vs dE/dx #2 | 4/3 | 4.0 | 57.0 | 5.4 | 3.3 | - | I | 02 | |
| | 4/9 | 1.4 | 56.7 | 1.5 | - | - | I | 02 | Post change |
| Range vs dE/dx sensor | 4/3 | 105.7 | 155.3 | 8.3 | 4.0 | - | I | 02 | |
| R vs dE/dx E 1 & 2, sensor | 4/3 | >118 | - | - | - | 0.7 | I | 02 | |
| | 5/7 | 38.9 | 136.4 | 4.4 | - | - | A&R | 02 | |
| | 6/21 | 21.6 | 145.8 | 1.0 | 11.6 | 1.1 | I | 02,04 | |
| | 10/24 | 42.0 | - | 3.5 | - | - | F | 04,03 | |

Magnetization

| Item | Date | Initial Perm | Post Expos. | Post Deperm | Induced Stray (0.26 Gauss) | | Test | S/N | Notes |
|--------------------------|----------|--------------|-------------|-------------|----------------------------|------|------|----------|-----------|
| FACET C | | | | | | | | | |
| Encoder-Converter | 3/28 | 2.0 | 10.4 | 0.5 | 2.0 | 1.8 | I | 01 | |
| Telemetry Encoder | 1/28 | 23.2 | - | - | - | - | I | 02 | |
| DDP Model C | 1/22 | 24.0 | - | - | - | - | I | 02 | |
| DDP Model D | 1/22 | 11.2 | - | - | - | - | I | 02 | |
| O.A. Sensor | | | | | | | | | |
| DDP Model B | 1/22 | 23.2 | - | - | - | - | I | 03 | |
| Optical Aspect Converter | 3/21 | 2.4 | 5.6 | 0.8 | 1.9 | - | I | 01 | |
| DDP's + Encoder | 11/22 | 29.9 | - | - | - | - | I | 02,03,02 | |
| DDP's + Enc. + Conv. | 4/8 | 27.0 | 154.0 | 20.6 | 24.8 | 1.8 | F | 02,03,02 | |
| FACET D | | | | | | | | | |
| Programmer #4 | 4/10 | 34.0 | 266.5 | 32.0 | 4.2 | - | I | - | |
| | 5/28 | 4.8 | 108.0 | 4.6 | 11.0 | - | I | 01 | |
| Programmer #3 | 4/10 | 1.4 | 20.4 | 1.2 | 4.3 | - | I | 01 | |
| Programmers 3 & 4 | 4/9 | 73.8 | 230.8 | 31.9 | - | - | I | - | |
| Fluxgate A Elect. | 5/20 | 3.2 | 31.7 | 1.0 | 4.2 | - | I | 01 | |
| | 7/10 | 1.2 | 10.6 | 0.4 | 3.6 | - | I | - | |
| Fluxgate Sig. Proc. | 5/20 | 0.9 | 1.2 | 0.4 | 1.2 | - | I | 01 | |
| Fluxgate Electronics | 1/7 | ≤8 | 129.0 | 0.8 | 10.1 | <0.2 | I | 01 | |
| 1 & 2 + Sig. Proc. | 5/20 | 3.2 | 31.7 | 1.0 | 4.2 | - | I | 01 | |
| Proton Analyzer | 12/18/62 | 2.4 | 138 | 1.6 | <8 | 8 | I | 02 | |
| | 2/4 | 11.2 | 138.4 | 0.7 | - | - | A&R | 02 | |
| | 3/4 | 2.8 | 7.1 | 2.8 | 1.7 | - | A&R | 02 | No ribbon |
| | 4/18 | 4.1 | 17.3 | 1.9 | 1.9 | 8 | I | 03 | |
| | 10/24 | 2.2 | - | 1.7 | - | - | F | 06 | |
| Ion Chamber | 12/7/62 | <8 | - | - | <8 | <8 | I | - | |
| | 4/1 | 7.6 | 51.4 | 3.9 | 3.2 | <8 | I | - | |
| | 5/15 | 1.8 | 7.2 | 0.5 | 1.7 | 1.0 | I | 03 | |
| FACET E | | | | | | | | | |
| Geiger Ctr. Tel. | 2/14 | 20.8 | 166.4 | 3.2 | 23.2 | <0.1 | I | 01 | |
| | 10/24 | 10.7 | - | 5.6 | - | - | I | 02 | |
| | 10/25 | 9.9 | - | 1.5 | - | - | F | 02 | |
| | 11/9 | 31.4 | - | 9.1 | - | - | F | 01 | |
| Programmer #1 | 4/10 | 1.3 | 16.4 | 0.9 | 1.3 | - | I | 01 | |
| Programmer #2 | 4/10 | 1.1 | 7.9 | 0.9 | 1.5 | - | I | 02 | |
| Programmer 1 & 2 | 4/8 | 2.5 | 20.2 | 0.8 | 20.0 | - | I | 01,02 | |

Magnetization

| Item | Date | Initial Perm | Post Expos. | Post Deperm | Induced Stray (0.26 Gauss) | | Test | S/N | Notes |
|-----------------------|-------|--------------|-------------|-------------|----------------------------|-------|-------|-----|-------|
| FACET F | | | | | | | | | |
| Thermal Ion | 5/13 | 3.9 | 28.9 | 1.9 | 4.2 | 159.6 | I | 01 | |
| Fluxgate Electr. "B" | 5/20 | 2.0 | 21.1 | 0.7 | 2.4 | - | I | 01 | |
| | 6/12 | 0.5 | 13.3 | 0.1 | 4.1 | - | I | - | |
| Solar Array Regulator | 3/22 | 0.4 | 2.1 | 0.1 | 0.5 | <0.1 | I | 03 | |
| Prime Converter | 3/22 | 8.8 | 117.6 | 10.4 | 10.4 | 35.2 | I | 03 | |
| | 3/27 | 24.0 | - | - | - | 87.7 | A&R | 02 | |
| | 4/10 | 14.9 | - | - | - | 46.0 | A&R | 02 | |
| | 4/26 | 12.7 | 94.3 | 8.1 | 7.3 | 20.7 | I | 04 | |
| | 4/29 | 10.5 | - | - | - | 14.5 | A&R | 04 | |
| | 4/29 | 14.7 | - | - | - | - | A&R | 02 | |
| | 5/10 | 3.3 | 94 | 8.1 | 7.3 | 2.9 | I | 06 | |
| | 5/17 | 4.0 | 60.5 | 3.3 | 14.7 | 4.2 | A&R | 06 | |
| | 6/18 | 8.6 | 79.9 | 2.5 | 7.7 | 6.0 | I | 07 | |
| | 9/24 | - | - | - | - | 5.1 | A&R | 03 | |
| | 10/28 | 17.9 | 82.5 | 2.0 | 6.5 | 9.1 | A&R | 04 | |
| 11/4 | 25.9 | - | 1.5 | - | - | F | 03 | | |
| FACET G | | | | | | | | | |
| R&RR Transmitter | 3/29 | 2.4 | - | 1.7 | - | - | I | 01 | |
| | 4/11 | 3.0 | 6.5 | 1.8 | 1.8 | - | I | 07 | |
| R&RR #3 | 3/29 | 15.6 | - | 0.4 | - | - | I | 01 | |
| | 4/11 | 1.2 | 14.0 | 1.8 | 2.4 | - | I | - | |
| R&RR #2 | 3/29 | 0.5 | - | 0.5 | - | - | I | 01 | |
| | 4/11 | 1.1 | 15.5 | 0.5 | 0.3 | - | I | - | |
| R&RR #1 | 3/29 | 3.4 | - | 0.9 | - | - | I | 01 | |
| | 4/11 | 0.8 | 14.9 | 0.8 | 1.0 | - | I | - | |
| R&RR Trans. 1, 2, & 3 | 3/29 | 15.0 | 80.0 | 0.5 | 10.9 | 0.9 | I | 01 | |
| | 4/11 | 2.0 | 59.9 | 3.5 | 7.0 | 0.9 | I | - | |
| Performance Parameter | 1/29 | 1.2 | 8.7 | 0.3 | 0.6 | >8 | I | 01 | |
| | 2/11 | 1.1 | 8.7 | 0.3 | 0.6 | 14.6 | A&R | 01 | |
| | 2/20 | - | - | - | - | 5.0 | A&R | 01 | |
| | 3/6 | 1.0 | 2.7 | 0.4 | 1.3 | 12.2 | I | 03 | |
| | 3/28 | - | - | - | - | 7.9 | A&R | 01 | |
| | 4/12 | - | - | - | - | 7.5 | A&R | 01 | |
| | 5/4 | - | - | - | - | 1.6 | Stray | 02 | |
| | 5/4 | - | - | - | - | 1.7 | Stray | 03 | |
| | 5/4 | - | - | - | - | 2.5 | I | 04 | |
| | 5/4 | - | - | - | - | 1.9 | Stray | 05 | |
| | 11/8 | 8.2 | - | 0.4 | - | - | F | 04 | |
| Relay & Despin timer | 2/20 | 276 | - | - | - | - | I | 01 | |
| | 4/10 | 21.5 | 266.5 | 32.0 | 1.3 | 2.6 | F | 01 | |
| | 10/24 | 39.3 | - | 36.3 | - | - | F | 02 | |
| | 11/9 | 44.4 | - | 32.0 | - | - | F | 03 | |

Magnetization

| Item | Date | Initial Perm | Post Expos. | Post Deperm | Induced Stray (0.26 Gauss) | | Test | S/N | Notes |
|--------------------------|---------|--------------|-------------|-------------|----------------------------|--------|------|-----|--|
| FACET H | | | | | | | | | |
| Plasma Probe #1 | 4/15 | 5.5 | 48.8 | 0.3 | 1.4 | - | I | 01 | |
| | 5/9 | 7.1 | 44.3 | 0.9 | - | - | I | - | |
| Plasma Probe #2 | 5/9 | 4.9 | 26.6 | 1.1 | - | - | I | - | |
| Plasma Probe Sensor | 5/9 | 8.5 | 29.6 | 5.7 | - | - | I | - | |
| P.P. 1, 2, Sensor | 12/4/62 | < 8 | - | - | < 8 | < 8 | I | - | |
| | 5/8 | 15.2 | 114.6 | 7.9 | 10.7 | 0.9 | I | - | |
| R vs dE/dx Parts | | | | | | | | | |
| Photo-multiplier tube | 4/23 | 46 | 85 | 6.9 | - | - | I | - | |
| S.S. Screws (12) | 4/23 | < 0.2 | < 0.5 | << 0.1 | - | - | I | - | |
| Solid State detector | 4/23 | < 0.1 | < 0.1 | - | - | - | I | - | |
| Ames Exp. Transformers | 5/6 | < 0.1 | < 0.5 | << 0.1 | 0.2 | << 0.1 | I | - | |
| E vs dE/dx P.S. | 4/19 | 2.3 | 20.2 | 1.2 | 2.7 | 13.0 | I | 8/1 | |
| | 4/26 | - | - | - | - | 28.1 | A&R | 8/1 | |
| | 6/14 | - | - | - | - | 7.5 | A&R | 8/1 | |
| | 6/20 | 1.4 | 7.9 | 0.7 | 1.4 | - | A&R | 8/1 | |
| | 6/20 | - | - | - | - | 2.3 | A&R | 8/1 | |
| Transistors | | | | | | | | | |
| 2N1908 | 6/17 | 3.3 | 16.2 | 0.4 | 0.5 | - | I | - | |
| 2N1724 | 6/25 | 2.3 | 2.4 | 0.3 | 0.5 | - | I | - | |
| STC 5553 | 6/25 | 0.3 | 1.3 | 0.1 | 0.4 | - | I | - | |
| Relays | | | | | | | | | |
| Babcock BR5 | 3/4 | 6.9 | - | - | - | - | I | - | |
| BR 9AX | 3/4 | 10.8 | - | - | - | - | I | - | |
| P&B SL11D | 3/4 | 72.0 | - | - | - | - | I | - | |
| Tuning Fork | | | | | | | | | |
| 63069 | 4/18 | 1.3 | 128.4 | 0.9 | 3.7 | 0.1 | I | - | |
| 4896 | 4/18 | 2.4 | 31.6 | 0.9 | 2.4 | - | I | - | |
| Battery | 3/21 | << 0.1 | 0.1 | << 0.1 | << 0.1 | 87.2 | I | 01 | |
| | 3/27 | - | - | - | - | 12.8 | A&R | 02 | |
| | 4/6 | - | - | - | - | 6.1 | A&R | 01 | |
| | 4/13 | - | - | - | - | 4.7 | A&R | 01 | |
| | 6/26 | 0.1 | 0.1 | < 0.1 | 0.1 | 4.7 | A&R | - | |
| | 9/20 | - | - | - | - | 4.9 | A&R | 08 | |
| | 11/1 | < 0.1 | - | - | - | - | F | 06 | |
| Yardney Cell Sil Cad 5AH | 4/6 | < 0.1 | - | - | - | ~ 7 | I | 5AH | Plastic case 3 cells back to back |
| | 4/6 | - | - | - | - | ~ 7 | I | 5AH | |

Magnetization

| Item | Date | Initial Perm | Post Expos. | Post Deperm | Induced Stray (0.26 Gauss) | | Test | S/N | Notes |
|---|--------|--------------|-------------|-------------|----------------------------|-----|------|------|------------|
| Yardney Cell 12AH | 4/6 | < 0.1 | - | - | - | - | I | 4P | Steel case |
| 12 AH | 4/6 | < 0.1 | - | - | - | - | I | 5P | Steel case |
| 12 AH | 4/6 | < 0.1 | - | - | - | - | I | 6P | Steel case |
| Sonotone NICAD 3 AH | 4/6 | 7 | - | - | - | - | I | 2P | |
| 4 AH | 4/6 | 67 | - | - | - | - | I | 1P | |
| 12 AH | 4/6 | 100 | - | - | - | - | I | 3P | |
| Ion Chamber Parts | | | | | | | | | |
| GM Tube A | 3/4 | < 0.2 | 0.9 | < 0.2 | 0.2 | - | I | 223 | |
| B | 3/4 | < 0.2 | 1.0 | < 0.2 | 0.2 | - | I | 223 | |
| P.S. ML 165-1 | 3/4 | 1.6 | 13.2 | 1.6 | 1.0 | - | I | - | |
| Shield Assembly | 3/4 | < 0.2 | < 0.2 | < 0.2 | < 0.2 | - | I | - | |
| Electronics board | 9/10 | 1.8 | 20.1 | 0.6 | 2.2 | - | I | D | |
| GM Counter Telescope | 6/24 | 0.1 | 0.1 | << 0.1 | 0.1 | - | I | - | |
| U.V. Converter | 3/30 | 0.5 | 3.8 | 0.2 | 1.1 | 0.4 | I | - | |
| U.V. Regulator | 6/17 | 1.4 | 7.9 | 0.7 | 1.4 | - | I | - | |
| 1 Yr. Timer | 4/10 | 0.6 | 1.5 | 0.6 | 1.0 | 2.4 | I | 02 | |
| Dumping Circuit Resistor | | | | | | | | | |
| Dale NH 50 50Ω | 3/7 | < 0.1 | - | - | - | 0.2 | I | - | |
| RH 55 50Ω | 3/7 | < 0.1 | - | - | - | 1.6 | I | - | |
| RH 55 13Ω | 3/7 | < 0.1 | < 0.1 | - | - | 5.8 | I | - | |
| NH 50 13Ω | 5/1 | < 0.1 | - | - | - | 0.4 | A&R | 6314 | |
| Wiring Harness | 4/1 | 64.8 | - | - | - | - | I | - | |
| Magnetic Field Magnitude in Gammas at 24 Inches | | | | | | | | | |
| Solar Paddles | 9/19 | 0.3 | - | - | - | 4.3 | I | 05 | |
| | 11/5 | 0.2 | 0.7 | < 0.1 | - | - | I | 02 | |
| | 11/5-6 | 14.0 | 383 | 0.3 | - | - | A&R | 08 | |
| | 11/5-6 | 0.8 | 59 | 0.7 | - | - | A&R | 10 | |
| | 11/5-6 | 60.0 | 830 | 0.3 | - | - | A&R | 11 | |
| | 11/6-8 | 0.8 | 30 | 0.2 | - | 1.6 | A&R | 09 | |
| | 11/8 | - | - | - | - | 1.8 | A&R | 10 | |
| | 11/9 | 0.7 | - | - | - | - | A&R | - | Post T.V. |
| | 11/9 | 111 | 447 | 0.8 | - | - | A&R | 03 | |
| | 11/9 | 31 | 437 | 0.9 | - | - | A&R | 06 | |
| | 11/9 | 24 | 302 | 0.7 | - | - | A&R | 07 | |
| 11/22 | 0.1 | 1.4 | 0.9 | - | - | A&R | 02 | | |

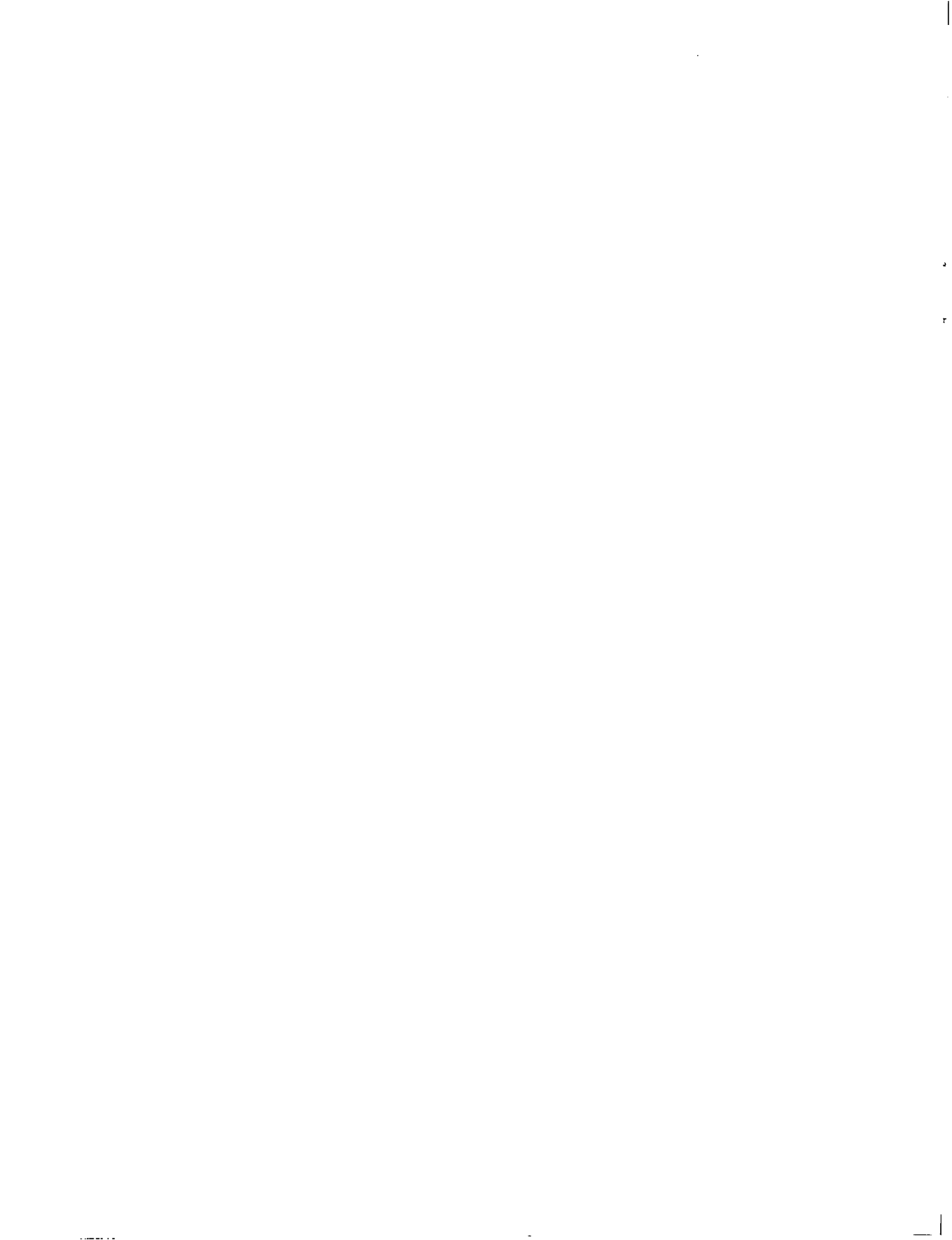

Appendix F

Components Magnetic Test Reports



(PRELIMINARY) REPORT OF AN ENVIRONMENTAL TEST

GENERAL INFORMATION

| | | | |
|--|--|--------------------|------------------------|
| 1. PROJECT S-74 IMP | 2. TYPE TEST MAGNETIC | 3. TAR NO. 3336 | 4. TEST DATE 4/1/63 |
| 5. TEST ITEM IMP Wiring Harness | 6. MODEL Prototype | 7. SERIAL NUMBER | |
| 8. ITEM LOCATION IN S/C: (IF S/C TEST, AXES ORIENTATION) | 9. TEST EQUIPMENT/FACILITY GSFC-MTF | | |
| 10. TEST OBJECTIVE(S) Test for magnetic components. | | | |

TEST PERSONNEL

| | |
|-------------------------------------|---|
| 11. TEST COORDINATOR H.P. Norris | 12. EVALUATION ENGINEER C. Harris |
| 13. PROJECT MANAGER REPRESENTATIVE | 14. DESIGN GROUP REPRESENTATIVE/EXPERIMENTER F. Carr |

TEST SET-UP

| | |
|---|--|
| 15. INSTRUMENTATION: Forster/Hoover Model 331 Tripole MF-T-165 Digital Recorder RFL 1890 Gaussmeter | |
|---|--|

| |
|---|
| 16. TEST SPECIFICATIONS: Environmental Test Specification S-74 IMP No. S-2-901, para. 4.2. |
|---|

| |
|--|
| 17. TEST PROCEDURE: Refer to Item # 16. |
|--|

| | |
|--|--|
| 18. PREPARED BY: C. Harris EVALUATION ENGINEER | 19. COORDINATION: H.P. Norris TEST COORDINATOR |
|--|--|

DISTRIBUTION: SCHEDULE "()"

PAGE 1 OF

TO: Magnetic Test Section Files
 FROM: C. A. Harris - Test Engineer
 SUBJECT: S-74 IMP Inner-Connecting Wiring

April 3, 1963

A series of magnetic tests were performed during the interval from March 29, 1963 to April 1, 1963 on various inner-connecting wires and inner-connecting wire samples. The wires which were tested were of the type which are to be used to inner-connect the components in the IMP spacecraft. In addition, the IMP wiring harness was tested as a unit. Subsequently, the individual harness wires were then tested separately.

The necessity for further tests of the IMP inner-connecting wires became evident when it was determined that the loops of Amphenol co-axial polyethylene teflon wire, which were used to inner-connect the Range & Rate Transmitter and Electronics units, indicated a permanent magnetism of 20 gamma at a distance of 12 inches from the magnetometer probe. The results obtained from further tests on various types of inner-connecting wires and wire samples is summarized in the attached table.

The magnetic test which was conducted on the IMP wiring harness (see attached Magnetic Test Report), revealed that the #26 black conductor Raychem wire had a magnetization of 20 gamma at a distance of 12 inches from the detector. On the basis of the data obtained from these tests, it is recommended that magnetic tests be conducted on samples of the actual wires which are to be used in the spacecraft.

C. A. Harris
 Test Engineer
 Magnetic Test Section

MAGNETIC TEST RESULTS

| WIRE TYPE - WIRE LENGTH | ALIGNMENT | MAGNETIZATION (GAMMA) AT 12 INCHES |
|---|-----------|---------------------------------------|
| Amphenol Coaxial Polyethylene Teflon - 8-1/2" | ⊥ | 5 |
| | | 38 |
| Amphenol #21-598 Coaxial - 10-1/2" | | 14 |
| | ⊥ | 2 |
| Raychem RG 178 Coaxial - 18" | | 10 |
| | ⊥ | 2 |
| Raychem RG 188 - 17" | ⊥ | 0.2 |
| Belden RG 55/U - 3-3/4" | | 0 (1 inch dist.) |

The inner-conductor and outer shield wires were tested for each type listed above and it was determined that the inner-conductor was magnetic while the shield wire was non-magnetic. After exposure to a 25 Gauss field, the magnetization for each wire increased except for the Belden RG 55/U wire which retained its non-magnetic properties.

PROJECT S-74 IMP
ITEM IMP Wiring Harness
TEST DATE 4/1/63

(PRELIMINARY) REPORT OF AN ENVIRONMENTAL TEST
(CONTINUATION SHEET)

(CONTINUATION OF ANY SECTION WHERE MORE SPACE IS REQUIRED.)

20. MAGNETIC TEST RESULTS:

The Imp Wiring Harness was first tested as a complete unit. The approximate center of the harness was at a distance of 19 inches from the magnetometer probe. The harness was then positioned so as to obtain its maximum measurable magnetization (this resulted in locating the outer group of wires and connectors approximately 12 inches from the probe). In this position, the harness indicated a magnetization of 54 gamma. Due to the fact that the harness was a complete unit, it was not possible to use the magnetometer to locate the source of magnetization. As a result, the individual wires were tested with an RFL 1890 Gaussmeter. From these tests, it was determined that the black conductor Raychem wire size # 26 was the source of magnetization. Further tests were then made with the magnetometer when the individual harness wire samples were obtained. The other sizes (#20, #22, and #28) of the black conductor Raychem wires were tested and determined to be non-magnetic.

Results of tests on 3 feet of the black conductor #26 Raychem wire placed with its nearest end 12 inches from the probe (parallel to the probe axis) and with the center of the wire 12 inches from the probe (perpendicular to the probe axis) are as follows:

| RAYCHEM #26 Black Conductor (Three Feet) | Magnetization Distance - 12 inches |
|---|---------------------------------------|
| Parallel | 20 gamma |
| Perpendicular | 4 gamma |

The other colors (green, yellow, red, orange, & brown) of Raychem wire sizes: # 20, 22, 26, & 28 was determined to be non-magnetic when tested at a distance of one inch from the probe.

Since the magnetic #26 black conductor wire was interlaced throughout the wiring harness, it was not possible to affirm the presence of other sources of magnetization; however, there was an indication that some of the short buss wires and a printed circuit plate had some magnetization. Since the black conductor #26 wire was employed throughout the harness, there is every indication that the measured 54 gamma field (complete wiring harness unit) can be attributed to the #26 black conductor wire.

(PRELIMINARY) REPORT OF AN ENVIRONMENTAL TEST

GENERAL INFORMATION

| | | | |
|--|--------------------------|--|-------------------------|
| 1. PROJECT S-74 IMP | 2. TYPE TEST MAGNETIC | 3. TAR NO. 3331 | 4. TEST DATE 3/29/63 |
| 5. TEST ITEM Range & Range Rate Transmitter and Electronics | 6. MODEL Prototype | 7. SERIAL NUMBER It 10,09,08,07 | |
| 8. ITEM LOCATION IN S/C: (IF S/C TEST, AXES ORIENTATION) G-1,2,3,4, | | 9. TEST EQUIPMENT/FACILITY GSFC-MTF | |
| 10. TEST OBJECTIVE(S) Initial Test | | | |

TEST PERSONNEL

| | |
|-------------------------------------|--|
| 11. TEST COORDINATOR H.P. Norris | 12. EVALUATION ENGINEER C. Harris |
| 13. PROJECT MANAGER REPRESENTATIVE | 14. DESIGN GROUP REPRESENTATIVE/EXPERIMENTER J. Rodgers |

TEST SET-UP

| |
|--|
| 15. INSTRUMENTATION: Forster/Hoover Model 331 Tripole MF-T-165 Digital Recorder |
| |
| |
| |
| |
| |
| |
| |

| |
|--|
| 16. TEST SPECIFICATIONS: Environmental Test Specification No. S-2-90], para. 4.2. |
| |
| |
| |

| |
|--|
| 17. TEST PROCEDURE: Refer to Item # 16. |
| |
| |
| |

| | |
|--|--|
| 18. PREPARED BY: C. Harris EVALUATION ENGINEER | 19. COORDINATION H. P. Norris TEST COORDINATOR |
|--|--|

DISTRIBUTION: SCHEDULE "()"

(PRELIMINARY) REPORT OF AN ENVIRONMENTAL TEST

TEST RESULTS

MAGNETIC TEST

| 20. TYPE OF MAGNETIZATION | RADIAL COMPONENT OF MAGNETIC FIELD IN GAMMA | | |
|--|---|-------------------------------|----------------------------------|
| | AT $\frac{18}{(3XL)**}$ INCHES | AT $\frac{19}{(6XL)*}$ INCHES | AT $\frac{36}{REQUESTED}$ INCHES |
| Permanent | | | |
| Initial | 66.9 | 56.7 | 5.2 |
| Post 25 gauss exposure | | | |
| Post Deperm | | | |
| Induced | | | |
| 26,000 gamma applied | 10.9 | 9.2 | 0.7 |
| Stray | | | |
| For 80 m amps. 240 ma. at 12 volts 50 volts | 0.9 | 0.8 | 0.1 ** |

21. DIRECTION OF MAGNETIC MOMENT: (Show by Simple Diagram)

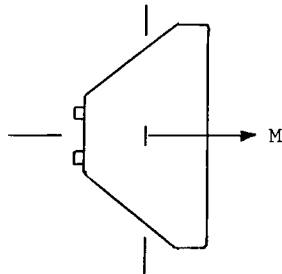

GIMBAL POSITION

AZIMUTH 0°
 ZENITH 180°

22. COMMENTS:

The complete R&RR unit - Transmitter, R&RR #3, R&R #2, and R&RR #1 was tested. At the conclusion of these tests, the complete unit was disassembled in order to determine which unit or units were the cause of the large initial perm value.

First, the inner-connecting loops of Amphenol coaxial Teflon wire were tested separately. At a distance of 12 inches each loop measured 20 gamma. With the inner-connecting wires removed from the complete unit, the following initial perm was measured at the 19 inch distance.

| | 18" ** | 19" | 36** |
|-----------------------------------|---------------|---------------|--------------|
| Initial Perm- w/o innerconnectors | 15.6 γ | 13.2 γ | 2.0 γ |

Next, the two mounting bolts were removed and the complete unit was measured with the following results:

| | 18"** | 19" | 36** |
|---|---------------|---------------|---------------|
| Initial Perm- w/o innerconnectors & bolts | 15.0 γ | 12.7 γ | 1.9 γ |
| Post 25 Gauss Exposure- w/o i.&b. | 80.0 γ | 67.8 γ | 10.0 γ |
| Post Deperm- w/o i.&b. | 0.5 γ | 0.4 γ | 0.1 γ |

* MAXIMUM LENGTH DIMENSION **Extrapolated Values.

(PRELIMINARY) REPORT OF AN ENVIRONMENTAL TEST

GENERAL INFORMATION

| | | | |
|---|--------------------------|---|-------------------------|
| 1. PROJECT S-74 IMP | 2. TYPE TEST Magnetic | 3. TAR NO. 3031 | 4. TEST DATE 2/12/63 |
| 5. TEST ITEM Ames Proton Analyzer Assemblies | 6. MODEL | | 7. SERIAL NUMBER |
| 8. ITEM LOCATION IN S/C: (IF S/C TEST, AXES ORIENTATION) | | 9. TEST EQUIPMENT/FACILITY GSCF Magnetic Test Facility | |
| 10. TEST OBJECTIVE(S) Perform pre-environmental tests of individual assemblies for analysis of magnetic characteristics. | | | |

TEST PERSONNEL

| | |
|--|--|
| 11. TEST COORDINATOR H. P. Norris | 12. EVALUATION ENGINEER C. A. Harris |
| 13. PROJECT MANAGER REPRESENTATIVE Dr. N. F. Ness | 14. DESIGN GROUP REPRESENTATIVE/EXPERIMENTER R. Hedlund |

TEST SET-UP

| | |
|--|--|
| 15. INSTRUMENTATION: | |
| Forster/Hoover Model 331 | |
| Tripole MF-T-165 | |
| Digital Recorder | |
| | |
| | |
| | |
| | |
| | |
| | |
| 16. TEST SPECIFICATIONS: Environmental Test Specifications, IMP, S-74 (unpublished) | |
| 17. TEST PROCEDURE: Magnetic Test Procedure (unpublished) | |

| | |
|---|---|
| 18. PREPARED BY: C. A. Harris EVALUATION ENGINEER | 19. COORDINATION: TEST COORDINATOR |
|---|---|

DISTRIBUTION SCHEDULE "()"

PAGE 1 OF ____

(PRELIMINARY) REPORT OF AN ENVIRONMENTAL TEST

TEST RESULTS

MAGNETIC TEST

| 20. TYPE OF MAGNETIZATION | RADIAL COMPONENT OF MAGNETIC FIELD IN GAMMA | | | | | |
|---------------------------|---|-------|-----------------------------------|--|---|-------|
| | AT $\frac{18}{(3XL)^*}$ INCHES | | AT $\frac{\quad}{(6XL)^*}$ INCHES | | AT $\frac{36}{\text{REQUESTED}}$ INCHES | |
| | Trans. | Elec. | | | Trans. | Elec. |
| Permanent | | | | | | |
| Initial | 2.6 | 22.6 | | | 0.3 | 2.8 |
| Post 25 gauss exposure | 2.7 | 160 | | | 0.3 | 19.9 |
| Post Deperm | 1.8 | 9.1 | | | 0.2 | 9.1 |
| Induced | | | | | | |
| 13,000 gamma applied | | | | | | |
| Spray | | | | | | |
| For _____ amps. | | | | | | |
| at _____ volts | | | | | | |

21. DIRECTION OF MAGNETIC MOMENT: (Show by Simple Diagram)

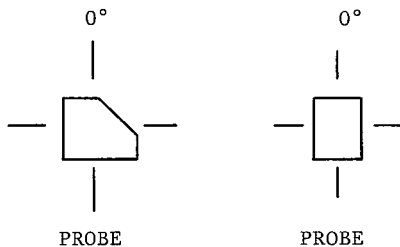

GIMBAL POSITIONS

| | | |
|--------------|---------|------|
| TRANSFORMERS | AZIMUTH | 180° |
| | ZENITH | 310° |
| ELECTRONICS | AZIMUTH | 20° |
| | ZENITH | 355° |

22. COMMENTS:

The transformer and etched circuits were tested first by being placed in the triangular mounting box (position in gimbal as indicated in above diagram). At the conclusion of these tests the electronics unit (without the transformer portion of the electronics) was placed in the mounting box and tested separately. Further tests were made on innerconnecting wire samples and duplicate electronic components (resistors, capacitors and resistors). Of these samples tested, the nickel wire and component wire produced measurable magnetic properties (in gimbal at 18 in. from the measuring probe):

| | | |
|-----------------------------|----------------|--------------------|
| 45" folded in 1-1/2" strips | Nickel Wire | Initial Perm - 0.4 |
| | | Post Exposure - 10 |
| 3" length | Component Wire | Initial Perm - 0.8 |
| | | Post Exposure - 2 |

** Extrapolated values.

*MAXIMUM LENGTH DIMENSION

(PRELIMINARY) REPORT OF AN ENVIRONMENTAL TEST

GENERAL INFORMATION

| | | | |
|--|--------------------------|--|------------------------|
| 1. PROJECT S-74 | 2. TYPE TEST MAGNETIC | 3. TAR NO. 3343 | 4. TEST DATE 4/3/63 |
| 5. TEST ITEM Ion Chamber Unit | 6. MODEL Flight | 7. SERIAL NUMBER | |
| 8. ITEM LOCATION IN S/C: (IF S/C TEST, AXES ORIENTATION) | | 9. TEST EQUIPMENT/FACILITY GSFC-MTF | |
| 10. TEST OBJECTIVE(S) ANALYSIS & REDUCTION TESTS. | | | |

TEST PERSONNEL

| | |
|------------------------------------|---|
| 11. TEST COORDINATOR H. NORRIS | 12. EVALUATION ENGINEER C. HARRIS |
| 13. PROJECT MANAGER REPRESENTATIVE | 14. DESIGN GROUP REPRESENTATIVE/EXPERIMENTER F. CARR |

TEST SET-UP

15. INSTRUMENTATION:

| |
|--------------------------|
| Forster/Hoover Model 331 |
| Tripole MF-T-165 |
| Digital Recorder |
| |
| |
| |
| |
| |
| |

16. TEST SPECIFICATIONS:

Environmental Test Specifications S-74 IMP No. S-2-901, para. 4.2.

17. TEST PROCEDURE:

Refer to Item # 16.

| | |
|--|--|
| 18. PREPARED BY: C. HARRIS EVALUATION ENGINEER | 19. COORDINATION: H. NORRIS TEST COORDINATOR |
|--|--|

| | |
|-----------|-------------------|
| PROJECT | S-74 IMP |
| ITEM | Ion Chamber Parts |
| TEST DATE | 4/3/63 |

**(PRELIMINARY) REPORT OF AN ENVIRONMENTAL TEST
(CONTINUATION SHEET)**

(CONTINUATION OF ANY SECTION WHERE MORE SPACE IS REQUIRED.)

20. MAGNETIC TEST RESULTS

In order to determine which component was contributing to the large Post Exposure field which was measured 4/1/63, the separate components of the Ion Chamber unit were measured after exposure to a 25 Gauss field and after having been Depermed. The results of these tests are as follows:

| COMPONENT | MEASUREMENT DISTANCE - 19 INCHES | |
|----------------------------------|----------------------------------|----------------|
| | POST EXPOSURE | POST DEPERM |
| Cinch Connectors | | |
| #1. | 0.7 gamma @ 1" | 0.7 gamma @ 1" |
| #2. | 0.4 " " | 0.4 " " |
| Teflon Wire 5" | No Field | No Field |
| Power Supply & Electronics Board | 45.9 gamma | 5.6 gamma |
| Power Supply | 8.0 " | 1.1 " |
| Electronics Board | 33.0 " | 5.3 " |

The results of these tests clearly indicate that the Electronics Board is the source of the large Post Exposure field that was measured with the complete unit. So that a comparison could be made between the test measurements of 4/1 and 4/3, the power Supply and Electronics Board were combined in their original positions and then separated after Exposure and Deperming and measured separately. The measurements taken on 4/1 are as follows:

| | Measurement Distance - 19 Inches | |
|------------------|----------------------------------|-------------|
| | Post Exposure | Post Deperm |
| Ion Chamber Unit | 43.6 gamma | 3.3 gamma |

(PRELIMINARY) REPORT OF AN ENVIRONMENTAL TEST

GENERAL INFORMATION

| | | | |
|--|--|-------------------------------------|------------------------|
| 1. PROJECT S-74-IMP | 2. TYPE TEST Magnetic | 3. TAR NO. 3134-35 | 4. TEST DATE 5/7/63 |
| 5. TEST ITEM E vs. dE/dx Photo. Tubes Range vs. dE/dx Telescope & Photo. Tubes | 6. MODEL Engr Proto | 7. SERIAL NUMBER EE-3-00 ER-3-02 | |
| 8. ITEM LOCATION IN S/C: (IF S/C TEST, AXES ORIENTATION) H-3 B-4 | 9. TEST EQUIPMENT/FACILITY CTF/GSFC | | |
| 10. TEST OBJECTIVE(S) Determine if photo multiplier tube is chief offender in Range vs. dE/dx Telescope. | | | |

TEST PERSONNEL

| | |
|--|---|
| 11. TEST COORDINATOR H. P. Norris | 12. EVALUATION ENGINEER A. G. Barr |
| 13. PROJECT MANAGER REPRESENTATIVE | 14. DESIGN GROUP REPRESENTATIVE/EXPERIMENTER Dr. Ness, Dr. Simpson |

TEST SET-UP

| | |
|------------------------|--|
| 15. INSTRUMENTATION: | |
| Forster/Hoover Mod 331 | |
| Tripole MF-T-165 | |
| Digital Recorder | |
| | |
| | |
| | |
| | |
| | |
| | |
| | |

| |
|---|
| 16. TEST SPECIFICATIONS: Environmental Test Specification S-74-IMP No. S-2-901, para 4.2. |
|---|

| |
|---|
| 17. TEST PROCEDURE: See section No. 16 |
|---|

| | |
|---|---|
| 18. PREPARED BY: A. G. Barr EVALUATION ENGINEER | 19. COORDINATION: H. P. Norris TEST COORDINATOR |
|---|---|

PROJECT S-74 - IMP
 ITEM ER-3-02
 TEST DATE 5/7/63

(PRELIMINARY) REPORT OF AN ENVIRONMENTAL TEST

TEST RESULTS

MAGNETIC TEST

| 20. TYPE OF MAGNETIZATION | RADIAL COMPONENT OF MAGNETIC FIELD IN GAMMA | | | |
|-----------------------------------|---|---------------------|----------------------------------|-------|
| | AT <u>19</u> INCHES | AT <u>19</u> INCHES | AT <u>18</u> INCHES REQUESTED | |
| | A | B | A* | B* |
| Permanent | | | | |
| Initial | 38.9 | 3.6 | 45.75 | 4.23 |
| Post 25 gauss exposure | 136.4 | 31.2 | 160.41 | 36.69 |
| Post Deperm | 4.4 | 1.4 | 5.17 | 1.65 |
| Induced | | | | |
| 13,000 gamma applied | | | | |
| Stray | | | | |
| For _____ amps. at _____ volts | | | | |

21. DIRECTION OF MAGNETIC MOMENT: (Show by Simple Diagram)

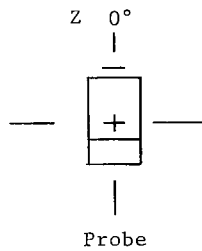
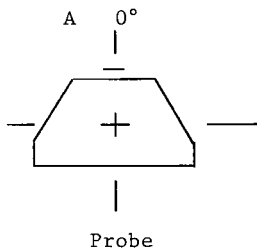

Gimbal Positions

Column A

- ↪ Azimuth 180°
- ↪ Zenith 350°

Column B

- ↪ Azimuth 90°, 270°
- ↪ Zenith 0°, 0°

22. COMMENTS:

A comparison of the data on the sheet with that on the continuation sheet indicates that the photo multiplier tube is indeed the chief source of permanent field.

* Extrapolated by inverse cube from column indicated.

*MAXIMUM LENGTH DIMENSION

(PRELIMINARY) REPORT OF AN ENVIRONMENTAL TEST
 (CONTINUATION SHEET)

| All Measurements Taken at 18 Inches | | | | | | | | | | | | |
|-------------------------------------|--------------------------|----------------|---|----------------|--------------------------|---------------|------------------|-------------|---|---------------------|----------------|---------------------|
| SER. 3.2.2.1 | | | SER. 4.2.151 | | | SER. 4.2.139 | | | SER. 6.2.67 | | | |
| Field in Gamma | Condition | Field in Gamma | Condition | Field in Gamma | Field in Gamma | Condition | Field in Gamma | Condition | Field in Gamma | Field in Gamma | Field in Gamma | |
| 21.9 53.8 | Initial Post 25 gauss | 25.9 69.6 | 10° | 18.6 53.8 | Initial Post 25 gauss | 29.3 212.0 | 10° 5° 50° | 63.4 1.4 | Initial Post 25 gauss Post deperm | 10.0 77.2 1.4 | 28.6 1.3 | 22.0 31.2 0.5 |
| | | | Fig. 1 $\frac{13}{4}$ | Fig. 2 | Fig. 3 | | | | | | | |
| | | | Leads that were clipped off formed in approximate volume found in fig. 1, 2 | | | | | | | | | |
| | | | 61.5 | 3.6 | 3.7 | | | | | | 2/7 | 2.8 |

REPORT OF AN ENVIRONMENTAL TEST

GENERAL INFORMATION

| | | | |
|---|--------------------------|--|----------------------------|
| 1. PROJECT S-74 IMP | 2. TYPE TEST MAGNETIC | 3. TAR NO. 3910 | 4. TEST DATE 6/20/63 |
| 5. TEST ITEM EE-2 POWER SUPPLY | | 6. MODEL ENG | 7. SERIAL NUMBER PS-8/1 |
| 8. ITEM LOCATION IN S/C: (IF S/C TEST, AXES ORIENTATION) H-1 | | 9. TEST EQUIPMENT/FACILITY GSFC-MTF | |
| 10. TEST OBJECTIVE(S) STRAY LOOP COMPENSATION TESTS | | | |

TEST PERSONNEL

| | |
|-------------------------------------|---|
| 11. TEST COORDINATOR H.P. NORRIS | 12. EVALUATION ENGINEER C. HARRIS |
| 13. PROJECT MANAGER REPRESENTATIVE | 14. DESIGN GROUP REPRESENTATIVE/EXPERIMENTER P. JANNICHE |

TEST SET-UP

| | |
|--------------------------|--|
| 15. INSTRUMENTATION: | |
| FORSTER/HOOVER MODEL 331 | |
| TRIPOLE MF-T-165 | |
| DIGITAL RECORDER | |
| | |
| | |
| | |
| | |
| | |
| | |

| | |
|-------------------------|---|
| 16. TEST SPECIFICATION: | T & E SPECIFICATION S-2-901 PARA. 4.2. |
|-------------------------|---|

| | |
|---------------------|-------------------|
| 17. TEST PROCEDURE: | REFER TO ITEM #16 |
|---------------------|-------------------|

| | |
|--|---------------------------------------|
| 18. PREPARED BY: C. HARRIS EVALUATION ENGINEER | 19. REVIEWED: TEST COORDINATOR |
|--|---------------------------------------|

(PRELIMINARY) REPORT OF AN ENVIRONMENTAL TEST
 (CONTINUATION SHEET)

(CONTINUATION OF ANY SECTION WHERE MORE SPACE IS REQUIRED.)

20. MAGNETIC TEST RESULTS.

20.

Matrix power supply PS 8/1 was initially measured for stray magnetization on 6/14 in order to determine if this part was the main source of the stray field of 6.6 gamma (at 18") measured 6/4 - units EE # 1 & 2 combined. At this time (6/14), the stray field produced by the p.s. was 7.5 gamma (at 18").

Tests were conducted with the matrix p.s. to determine the effectiveness of the three arrangements of compensation loops. Three loops with 25 turns each were wound on the p.s. and located as shown in the following sketch. Measurements were made as the individual loops were inserted in the circuit in order to determine the effectiveness of the compensation by each loop. All three loops effectively reduced the maximum stray field of the p.s.; however, due to the number of turns, each loop actually over compensated the field. Since each loop was positioned differently, the resultant compensated field for the p.s. at right angles to the main axial field (side & top) varied slightly. The following diagrams indicate the magnitudes and directions of these components for the p.s. without and with the compensation loops:

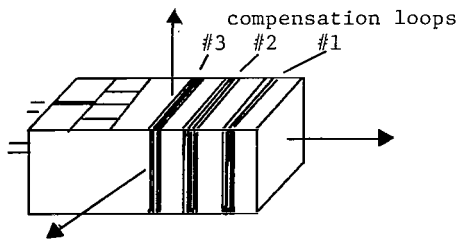

RADIAL COMPONENT OF MAGNETIC FIELD IN GAMMA AT 18 INCH

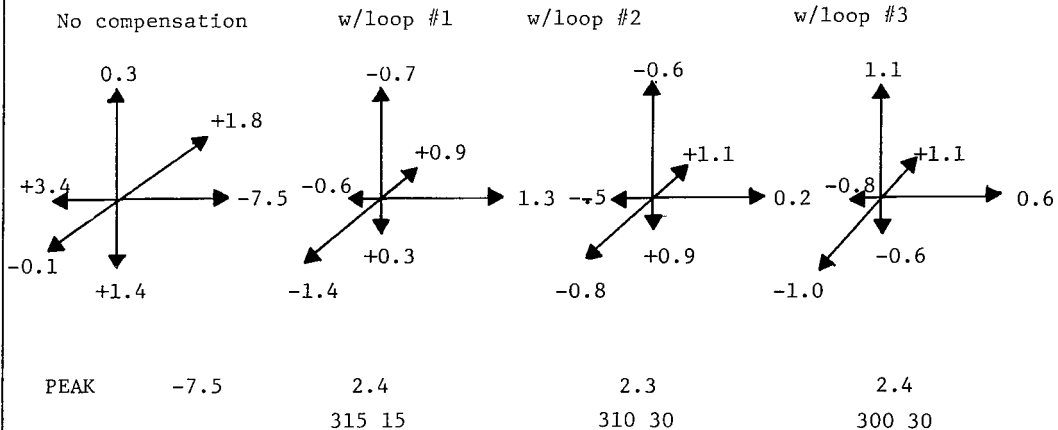

Appendix G

Facet C Comparison Data



REPORT OF AN ENVIRONMENTAL TEST
GENERAL INFORMATION

| | | | |
|---|--------------------------|--|------------------------------------|
| 1. PROJECT S-74 IMP | 2. TYPE TEST MAGNETIC | 3. TAR NOS. 3279, 3406, 3412 | 4. TEST DATES 5/16, 29; 6/11/63 |
| 5. TEST ITEM FACET "C" 4 - CARDS | 6. MODEL ENG. | 7. SERIAL NUMBER IT-1, 2, 3; IP-7A | |
| 8. ITEM LOCATION IN S/C: (IF S/C TEST, AXES ORIENTATION) FACET C | | 9. TEST EQUIPMENT/FACILITY GSFC-MTF | |
| 10. TEST OBJECTIVE(S) DEPERM AND VIBRATION COMPARISON TESTS | | | |

TEST PERSONNEL

| | |
|--------------------------------------|--|
| 11. TEST COORDINATOR H. P. NORRIS | 12. EVALUATION ENGINEER C. HARRIS |
| 13. PROJECT MANAGER REPRESENTATIVE | 14. DESIGN GROUP REPRESENTATIVE/EXPERIMENTER |

TEST SET-UP

| | |
|--|--|
| 15. INSTRUMENTATION: FORSTER/HOOVER MODEL 331 TRIPOLE MF-T-165 DIGITAL RECORDER VIBRATION TESTS: MB C-50 SHAKER | |
|--|--|

| | |
|--|--|
| 16. TEST SPECIFICATIONS: T & E SPECIFICATION S-2-901 TAR 3279 May 10, 1963 | |
|--|--|

| | |
|--|--|
| 17. TEST PROCEDURE: REFER TO SECTION # 16 | |
|--|--|

| | |
|--|---------------------------------------|
| 18. PREPARED BY: C. HARRIS EVALUATION ENGINEER | 19. REVIEWED: TEST COORDINATOR |
|--|---------------------------------------|

Magnetic Test Results

S-74 (IMP) Facet C Deperm and Vibration Tests

Summary

The results of the magnetic tests related to a comparison of differences between two modes of deperming and the effects of vibration of a depermed unit in either the geomagnetic field or the normal vibration exciter field which have been conducted with S-74 (IMP) Facet C components are presented. From these test results, the following information has been obtained:

1. The facet deperm is slightly more effective than the individual card deperm.
2. The depermed state of the facet and the individual cards is not appreciably altered when the facet is vibrated in earth's field.
3. The permanent magnetization of the depermed facet (along the component parallel to and in the direction of the field generated by the vibration exciter) is increased 36% when the magnitude of the vibration exciter field is approximately 8.5 gauss at the center of the facet.

A series of magnetic tests were conducted with S-74 (IMP) Facet C electronic card components to determine the differences between the deperming of individual cards and the deperming of the cards when assembled as a facet. In addition, tests were also conducted to determine the extent to which the depermed state of the components and the facet would be changed when they are vibrated in earth's field (0.5-0.7 gauss). Additional tests were performed with the depermed facet vibrated in a normal vibration exciter field in order to determine the possible perming effects of the vibration exciter.

For the purpose of these tests, the following electronic cards of the Facet C assembly were used: Encoder converter, DDP Model B, DDP Model C, and DDP Model D. When the electronic cards were combined in order to perform the facet measurements and tests, the cards were stacked in the following order: Encoder converter - top, DDP Model B, DDP Model C, and DDP Model D - bottom. The tests were conducted on the following dates: May 16, 1963 - Deperm and geomagnetic field vibration tests (table I); May 29, 1963 - Deperm and vibration in vibration exciter field (table II); and June 11, 1963 - Vibration in vibration exciter field (table III). All magnetic measurements were conducted at the Component Magnetic Test Facility and the vibration tests were performed in Building 7, on the C-50 vibration exciter (table IV and V).

The deperming tests which were performed in order to compare facet deperm vs card deperm were conducted in the following manner:

1. The individual cards were depermed along the axis of the maximum radial component.
2. The facet was depermed along the axis of the maximum resultant radial component.

In all cases, the measurements were made with the detector 18 inches from the center of the measured cards or facet. The results of these tests are listed in tables I and II. A comparison

between the two types of deperming indicates that, in the case of the Facet C cards, a slightly more effective deperme is obtained by deperming the facet rather than the individual cards.

The vibration tests with the facet vibrated in the earth's field were performed in the following two ways: (1) vibration of the facet after the cards were depermed individually, and (2) vibration of the facet after the facet was depermed. In order to vibrate the facet in earth's field, it was necessary to place the C-50 in the horizontal position so that the facet could be mounted at a distance of 19 inches from the top of the exciter while being vibrated. This position was necessary since the peak magnetic field generated by the C-50 at a distance of one inch above the exciter is 20 gauss. (See enclosed C-50 Vibration Exciter table IV). The results of these tests (table I) indicate a 5% increase in the maximum radial component of the facet and a slightly smaller overall change in the maximum radial components of the individually depermed cards. The test data also indicate that the post deperme stability for the two types of deperming are comparable.

The tests on May 29, 1963 (table II) were conducted with the facet mounted so that Card D was nearest to the top of the vibrator (field - 12 gauss) and the encoder converter card farthest away (field - 5 gauss). The vibration tests of June 11, 1963 (table III) were conducted with the facet placed on the C-50 in an inverted position. The encoder converter was nearest to the top of the vibrator and the DDP Model D card farthest away. When the facet was vibrated on the C-50 in the normal upright position May 29, 1963, the moments of two cards and the facet were directed downward; therefore, these moments decreased in magnitude while the two cards whose moments were directed upward were increased in magnitude. June 11, 1963, the facet assembly was placed on the C-50 in the inverted position so that the moments of the facet and two cards were directed upward. This resulted in an increase of the moment when vibrated. The average percentage change in the maximum radial component of the facet was 27% while the radial components of the facet parallel to the vibration exciter field were changed 36%.

Since the exposure field of the C-50 was 12 gauss at the base of the facet and 5 gauss at the top, inversion of the facet resulted in a change in the exposure field for the individual cards. For this reason, the percentage changes due to the vibration tests as listed in tables 2 and 3 are not equal. Due to the limited accuracy in the measurements ± 0.2 gamma, the data for the Encoder Converter Card seem somewhat erratic and is shown for comparison purposes only. The location of the maximum radial component of the DDP Model B Card is such that the increase in the maximum radial component after vibration shows only a 26% change while the other measurements show a change of more than 100%.

TABLE I

S-74 IMP DEPERM & VIBRATION TESTS
 MAXIMUM RADIAL MOMENT IN GAMMA AT 18 INCHES

MAY 16, 1963

| CARD | POST DEPERM - SEPARATE | POST DEPERM - FACET | % CHANGE |
|-------------------|------------------------|---------------------|----------|
| Encoder Converter | 1.0 | 0.5 | 50 |
| DDP Mod B | 8.2 | 5.9 | 28 |
| DDP Mod C | 11.1 | 10.3 | 7 |
| DDP Mod D | 15.8 | 15.4 | 3 |
| Facet | (30.1) | 31.2 | 1 |

(FACET DEPERM SEPARATE DEPERM)

VIBRATION TESTS - EARTH'S FIELD

| | PRE-VIBRATION | POST VIBRATION | |
|-------------------|---------------|----------------|----|
| Encoder Converter | 1.0 | 0.7 | 30 |
| B | 8.2 | 8.6 | 5 |
| C | 11.1 | 11.0 | 1 |
| D | 15.8 | 15.9 | 1 |
| Facet | (30.1) | 29.5 | 2 |
| Encoder Converter | (0.7) | 0.7 | 0 |
| B | (6.4) | 6.0 | 7 |
| C | (10.5) | 10.6 | 1 |
| D | (15.4) | 15.7 | 2 |
| Facet | 30.6 | 32.2 | 5 |

() values culled from data and not directly observed.

TABLE II

S-74 IMP DEPERM & VIBRATION TEST
 MAXIMUM RADIAL MOMENT IN GAMMA AT 18 INCHES

MAY 29, 1963

| CARD | POST DEPERM - SEPARATE | POST DEPERM - FACET | % CHANGE |
|-------------------|------------------------|---------------------|----------|
| Encoder Converter | 0.7 | 0.1 | 86 |
| DDP Mod B | 6.1 | 5.5 | 10 |
| DDP Mod C | 9.9 | 9.8 | 1 |
| DDP Mod D | 15.2 | 15.4 | 1 |
| Facet | 31.3 | 30.9 | 1 |

VIBRATION TEST - 12 GAUSS FIELD - DIRECTED UPWARD

| | PRE-VIBRATION | POST VIBRATION | |
|--|---------------|----------------|-----|
| Encoder Converter | 0.1 | - 1.7 | |
| B | 4.7 | 5.9 | 2 |
| C | 9.8 | 8.3 | 15 |
| D | 15.4 | 12.0 | 22 |
| Facet | 30.9 | 22.4 | 28 |
| ----- Radial Component Co-axial with Vibration Field ----- | | | |
| Encoder Converter | 0.0 | -0.8 | - |
| B | 1.5 | 3.4 | 127 |
| C | 9.4 | 7.6 | 19 |
| D | 12.4 | 8.7 | 30 |
| Facet | 26.0 | 16.3 | 37 |

TABLE III
 S-74 IMP FACET C VIBRATION TEST
 MAXIMUM RADIAL COMPONENT IN GAMMA AT 18 INCHES
 12 GAUSS FIELD - DIRECTED UPWARD

JUNE 11, 1963

FACET INVERTED

| CARD | PRE-VIBRATION | POST VIBRATION | % CHANGE |
|-------------------|---------------|----------------|----------|
| Encoder Converter | 0.7 | 0.3 | 57 |
| DDP Mod B | 5.0 | - 2.4 | 148 |
| DDP Mod C | 10.2 | 12.1 | 19 |
| DDP Mod D | 15.1 | 17.4 | 15 |
| Facet | 31.4 | 39.5 | 26 |

----- Radial Component Co-axial with Vibration Field -----

| | | | |
|-------------------|------|-------|-----|
| Encoder Converter | 0.5 | 2.2 | 340 |
| B | 1.8 | - 0.6 | 133 |
| C | 9.5 | 11.7 | 23 |
| D | 12.7 | 14.4 | 13 |
| Facet | 26.7 | 36.0 | 36 |

TABLE IV
 EXCITER TABLE - MB C-50

| Height Above Center Inches | Field in Gauss | | |
|-------------------------------|-------------------|--------------|-------------------|
| | Background (1) | DC On (2) | DC & AC On (3) |
| 2 | 0.34 | 20.0 | No Change |
| 3 | 0.31 | 14.0 | No Change |
| 4 | 0.27 | 11.5 | No Change |
| 5 | 0.25 | 8.1 | No Change |
| 6 | 0.35 | 6.5 | No Change |
| 8 | 0.38 | 4.8 | No Change |
| 11 | 0.52 | 2.7 | No Change |
| 13 | 0.60 | 2.0 | No Change |
| 16 | 0.60 | 1.0 | No Change |
| 19 | 0.60 | 0.6 | No Change |

The peak field of 20 gauss (initial current 45 amperes) at 2 inches gradually decreased to 10 gauss (current stabilized at 40 amperes) after the DC current had been applied to the coils. The time for this decrease was approximately ten minutes.

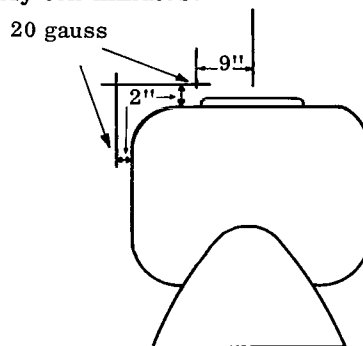

TABLE V
EXCITER TABLE - MB C-125

| Height Above Center Inches | Background (1) | Field in Gauss | |
|-------------------------------|-------------------|----------------|-------------------|
| | | DC On (2) | DC & AC On (3) |
| 1 | 2.5 | 20.0 | No Change |
| 2 | 2.2 | 17.0 | No Change |
| 3 | 1.8 | 14.0 | No Change |
| 4 | 1.7 | 12.0 | No Change |
| 5 | 1.4 | 10.0 | No Change |
| 6 | 1.2 | 8.2 | No Change |
| 7 | 1.0 | 6.7 | No Change |
| 8 | 0.9 | 5.7 | No Change |
| 9 | 0.8 | 4.7 | No Change |
| 10 | 0.7 | 4.0 | No Change |
| 11 | 0.65 | 3.4 | No Change |
| 12 | 0.6 | 2.8 | No Change |
| 16 | 0.6 | 1.0 | No Change |

The peak field of 20 gauss gradually decreased to 13.5 gauss about ten minutes after the application of the DC power.

Appendix H

Atlantic Missile Range Magnetic Field Survey

MEMORANDUM
Report No. 635-001
July 29, 1963

MEMORANDUM

To: Mr. Kenneth Mercy
Acting Head, Systems Evaluation Branch

From: Mr. William Kenney
Engineering Design Branch

Subject: Magnetic Measurements during Pre-Launch Operations of a Thor Delta Vehicle

SUMMARY

A magnetic survey was conducted for the S-74 (IMP) Project at the Atlantic Missile Range (AMR) to determine the magnetic environment present during the pre-launch operations. This is the first time magnetic measurements have been made of pre-launch operations. Three areas were covered: (1) the spacecraft laboratory, (2) the spin facility, and (3) the launch complex itself. The results of measurements taken in these areas indicate that there are some high fields (a maximum of 2.2 kilogauss was recorded), but fortunately these high fields fall off rapidly. Some tools which could be used near the spacecraft were found to have a field of 50 gauss.

The effect of the service tower as it moved away from the missile was measured and found to produce a change of 0.1 gauss. It is recommended that measurements be made at launch time to insure that handling equipment and tools or modifications of facilities themselves do not introduce any high fields near the spacecraft. Reference: X-623-63-65, Project Delta, Test Plan for Magnetic Measurements at AMR.

INTRODUCTION

Magnetic measurements were made at AMR on July 8, 9, and 10. The referenced test plan was followed with few exceptions. The required instruments were obtained and calibrated before leaving GSFC. On arrival at AMR, it was determined to make measurements first at the launch

complex. The T-10 test of Syncom was in progress and measurements were made during very similar launch day operations. A brief physical tour of the area to be measured was made to determine possible sources of fields. Notes were made of these objects to assure a more detailed analysis later. For the most part, two portable gaussmeters were used, one for dc and one for ac. Readings were taken of the ac and dc fields present. The maximum value of fields was obtained by repositioning the probe. At high sources, the rate of fall-off was determined by measuring approximately 12 in. away from the source.

DETAILED ANALYSIS OF EACH AREA

Complex 17 - From Figure H-1, it can be seen that data was taken at all areas which could affect the spacecraft as it approaches the launcher. Possible sources of field were examined in more detail than others. Where values are not listed, the values were approximately earth's field or less than .1 gauss ac.

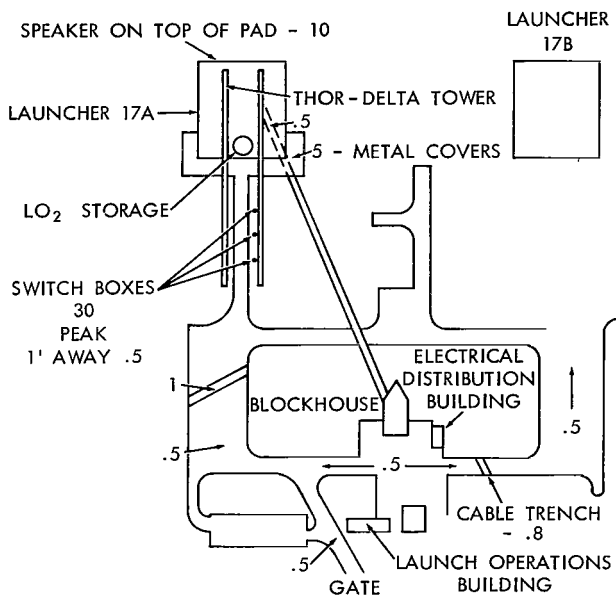

NOTE: A.C. MEASUREMENTS WERE MADE AT SAME LOCATIONS ALL READING LESS THAN .1.

ALL VALUE LISTED ARE IN GAUSS

Figure H-1—Complex 17.

Rather than measure the effect as the spacecraft was hoisted to level 9A, it was decided that it would be more meaningful to examine each level for possible high sources. Figure H-2 indicates magnetic fields that were observed on the various levels of the tower.

Effect of the Tower - An experiment was conducted to measure the over-all magnetic effect of the service tower as it was moved away from the missile. Anticipating that it might be possible to do this, provision was made for a long cable to connect the probe to the measuring instrument. A Hewlett-Packard probe was attached to the skin of the fairing and the cable was brought down the umbilical tower to the instrument on the pad. A summary of results is shown below:

| <u>Function</u> | <u>Change in Magnetic Field</u> |
|--------------------------|---------------------------------|
| Lower floors raised | 0.06 gauss |
| Level 9A floors raised | 0.13 gauss |
| Service tower moved back | 0.10 gauss |

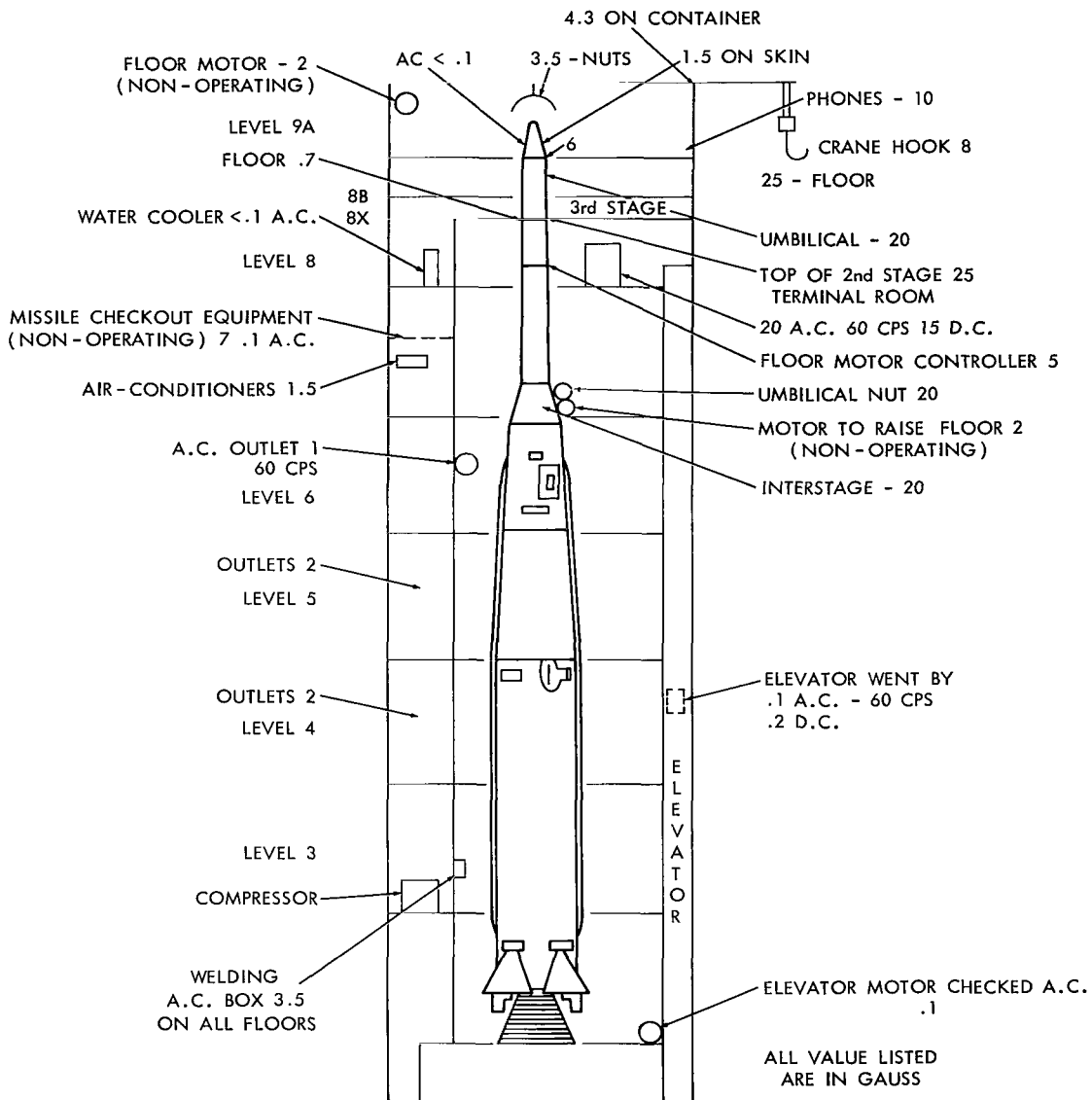

Figure H-2—Thor-Delta tower.

Additional Items - The transporter dolly and transfer truck were in the area and were checked. A field of three gauss was found on the bolts on top of the dolly. Some batteries being used on level 8B to power equipment in the missile had a field of five gauss. These were 24-cell NiCad, manufactured by the Sonotone Corporation.

Spacecraft Laboratory - Figure H-3 shows various fields that were measured in the spacecraft laboratory. Some of these areas are not completed. Benches and shelves were not in their final positions in the assembly area. One of the motors for the crane was measured on the ground (2 gauss). The doors in the shipping area were not installed. There was no equipment in the solar room.

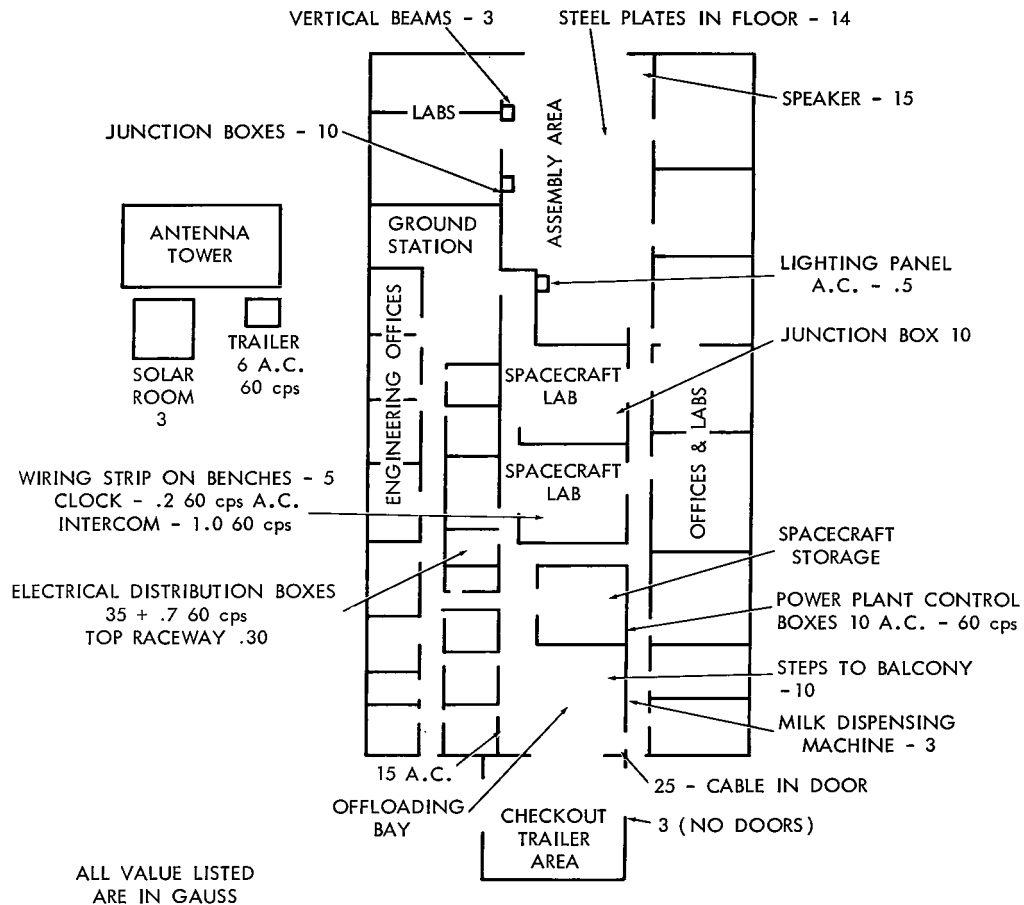

Figure H-3--Spacecraft laboratory Building A-E.

Spin Facility - The physical layout of the equipment used in the spin facility with their measured fields is shown in Figure H-4. It was here that the highest field was measured. In the bottom of the nozzle alignment jig, evidently some piece was permanently magnetized but localized to a very small area. One foot away earth's field was measured. A new large spin jig facility which is to be used for IMP had not arrived.

Other Items Measured

| <u>Item</u> | <u>Gauss</u> |
|--------------------------------|--------------|
| Hand Tools | |
| Screw driver | 50 |
| Socket Wrench | 7 |
| Lifting harness | 5 |
| Lifting beam with steel cables | 7 |
| Attach fitting | 1 |

| <u>Item</u> | <u>Gauss</u> |
|--------------------------------------|--------------|
| Fairing | |
| Connectors | 20 |
| Cable tie-down bolts | 3 |
| Carrying handle bolts | 3 |
| Spacecraft handling container | |
| Canopy rivets | 3 |
| Locking clips | 3 |
| X-248 Rocket motor | |
| Rivets in explosive bolt ring | 3 |
| Other parts | 1 |

CONCLUSIONS

Even though there are several objects which could affect the spacecraft, these objects would definitely have to be moved close to the spacecraft itself. For the most part, the high field objects are separated by at least twelve inches and are not normally removable. One class of objects which are movable and could be used on the spacecraft are hand tools. Therefore, it is recommended that non-magnetic tools be obtained and used. Also, it would be advisable to obtain non-magnetic clips and hardware for the fairing and the spacecraft container. The removal of permeable objects in the vicinity of a spacecraft is desirable. Therefore, to insure a more successful flight, it is recommended that final precautions be made at launch time. Personnel assigned to the spacecraft can be given instructions that magnetic equipment is not allowed near the spacecraft, under any circumstances. Personnel, with the proper equipment, can be assigned to "guard" the spacecraft from high fields. A check of areas can be made before the spacecraft is brought into the area. These last-minute measurements would take care of changes in facilities which could affect the spacecraft.

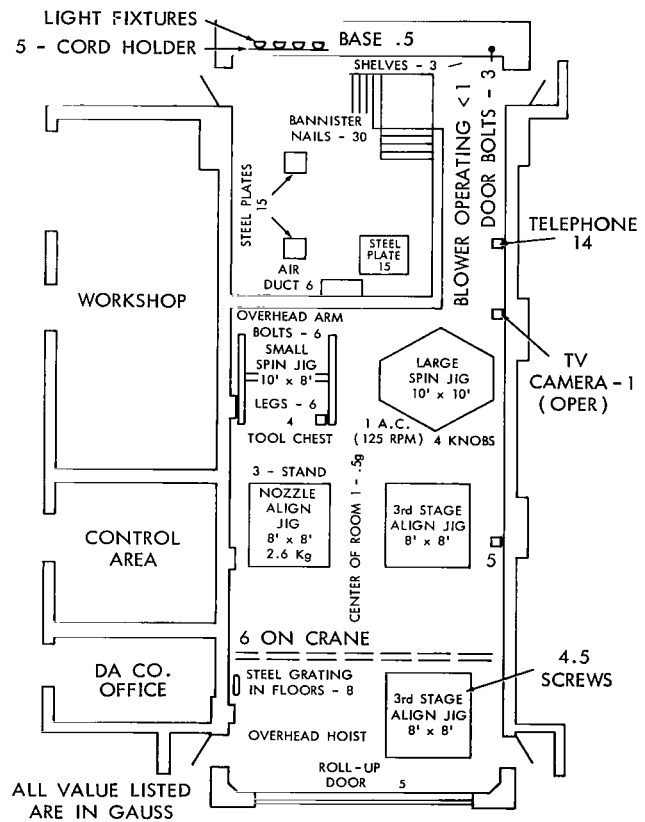

Figure H-4—Spin facility.

Appendix I

Perming Effects of Tools and Equipment

Engineering Design Branch Files

Mr. Charles Harris
Magnetic Test Section

Magnetization of Components with Magnetic
Tools and Equipment

Information has been gathered regarding the magnetizing effects of magnetized tools and equipment which have been used to expose various samples. The results of the tests performed clearly indicate that magnetic tools can magnetize items; however, the intensity of magnetization would be somewhat less than that of an applied exposure field of equal magnitude. In addition, it is possible for the tools to demagnetize instead of magnetizing the item if their fields are in opposition. Where requirements demand that components or spacecraft not be magnetized to any noticeable extent, then, in order to remove any possible magnetizing effects from tools either or both of the following courses of action are recommended:

1. Deperm all tools which might come in contact with the components or spacecraft.
2. Monitor the components or spacecraft so as to prevent the use of magnetic tools near the components or spacecraft.

There has arisen some question in regard to what effect tools and equipment which are magnetic would have on components when the components are exposed to the tools. In order to resolve these questions, a number of measurements have been taken and the results are now summarized.

Data on the magnitude of the field which might be found with various tools is included in the enclosed list of tools (Table I-1) which have been measured. In the case of these particular tools, the maximum field detected was 100 gauss (measured on the surface of the item). For all the tools, the fall off rate of the field was such that at 1 inch from the item, the magnitude of the field was less than one gauss. At 12 inches, the field would be less than 500 gamma. In order for the tool to have any effect on the component, it would be necessary to bring the component to within a distance of less than 1 inch from the tool or vice versa.

The extent to which a component is magnetized by a tool depends mainly upon the magnitude and uniformity of the exposure field and the internal composition of the component. An example of this increase in the permanent magnetization can be seen in the enclosed Table I-2. In this case

Table I-1
Assorted Tools.

| Item | Maximum Field on Surface in Gauss |
|--|-----------------------------------|
| Holding Screwdriver | 30 |
| Diagonals (small) | 33 |
| Scissors (long) | 12 |
| 6-inch Steel Tape | 5.5 |
| Red-Handled Strippers | 20 |
| Dividers | 25 |
| Diagonals (small) | 14 |
| 12-inch Rule Steel | 30 |
| Phillips Screwdriver (6" long) (Table I-3) | 55 |
| Long Nose Pliers (small) | 13 |
| Long Nose Pliers (large) | 10 |
| Scriber | 100 |
| Socket Box | 8 |
| Scale 6-inch Steel | 20 |
| Hammer | 5 |
| Hatchet | 4 |
| Simpson Multimeter (on meter glass face) | +125 |

Table I-2
Magnetic Field Effect.

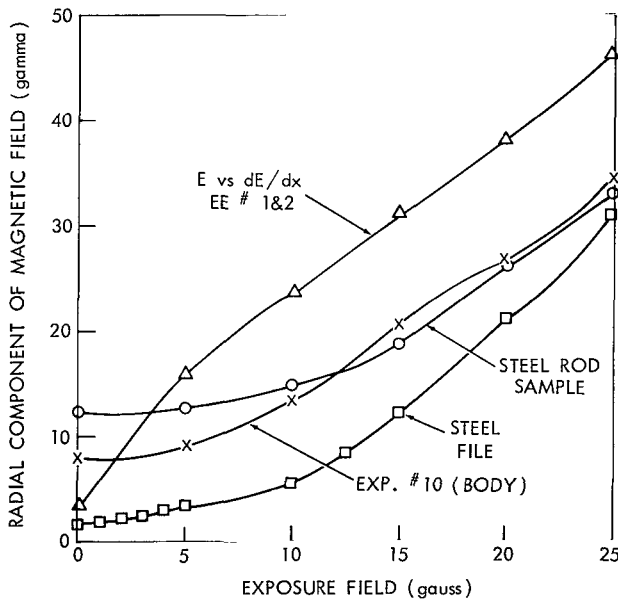

the exposure field is quite uniform so that the extent of magnetization is greater than that obtained with a tool which had the same magnitude of field. This table indicates that the normal component or item could be exposed to a field of less than 5 gauss without a significant increase in its initial permanent magnetization; whereas, a component with a smaller field is noticeably effected. A series of comparison tests were performed with Raychem #26 wire (previously tested and determined to be magnetic). It was determined that when the wire was exposed to a field greater than 5 gauss, the permanent magnetization of the wire increased, (Table I-3). In the case where the wire was cut with diagonal cutters (maximum field on surface 33 gauss) the permanent magnetization of the wire increased from 0.8 gamma to 4.8 gamma (distance - 12 inches). When this wire was exposed to a uniformly

directed 25 gauss perming field, the permanent magnetization increased from 0.8 gamma to 26.4 gamma (distance - 12 inches). Although the 33 gauss exposure (diagonals) was not as effective as the 25 gauss field which is used for magnetic tests, the permanent magnetization of the wire did increase as it was cut by the diagonals.

In the case where it is necessary to use various tools near components, it would be preferred to have these tools depermed in order to reduce the magnitude of the field on the tool so

that it would not magnetize a component. In the specific case listed below, it is possible to compare the magnetizing effects of a tool (normal random field) with the slightly higher field which was created when the tool was exposed to a uniformly directed 25 gauss field. After the tool was depermed, it was used in an attempt to magnetize a piece of the Raychem wire, but it did not magnetize the wire indicating that the depermed tool could safely be used on components.

In addition to tools, a Simpson multimeter was measured and a field of 125 gauss (on the glass surface of the meter) was detected. Samples, when exposed to this field, were also magnetized to some extent. This indicates the need for keeping meters and such items away from components.

Even though components might come in contact with tools and equipment with large fields, it still would be possible for the component to have its magnetic field decreased instead of increased according to the polarity of the exposure field.

Table I-3

Phillips Long-Handled 6-inch Screwdriver.

| Magnetization | Peak Field in Gauss on Surface | Raychem Wire % increase at Initial Magnetization |
|------------------------|--------------------------------|--|
| Initial | 55 Gauss | 83 |
| Post 25 Gauss Exposure | 60 Gauss | 170 |
| Post Deperm (ac) | 2.8 Gauss | 0 |

Charles A. Harris



Appendix J

Spacecraft Magnetic Check at Fredericksburg, Va.

In order to determine whether the magnetic field experiment aboard the IMP spacecraft is operating properly, it is necessary to simulate interplanetary magnetic field conditions and place the spacecraft in such an environment so that the magnetic field sensing equipment can be checked for range and calibration. The Fredericksburg Magnetic Observatory has a facility for creating this environment.

The purpose of these notes is to outline the tests and the procedure so that the personnel involved may be better informed and thus participate more fully in the orderly completion of the program.

The tests to be run fall into three general categories:

1. Fluxgate Magnetometers
2. Fluxgate Signal Processor
3. Rubidium Vapor Magnetometer

1. Fluxgate Magnetometers

There are five tests to be conducted on each fluxgate magnetometer: zero, sensitivity calibration, linearity, saturation, and polarity.

(a) Zero check and sensitivity calibration

These two tests are run at the same time. The fluxgate booms are aligned such that the fluxgate sensors lie in the north-south direction in the horizontal plane. The sensors are then, on alternate fluxgate encoder frames, unplugged and reversed. At each position the appropriate frame should be printed out from the portable de-com. and the sensor direction noted on the print out by a plus or minus sign. To conform with previous convention and to assure uniformity, the white end of the sensor plugged into the cable is positive.

The sensitivity calibration is automatically recorded at each print out.

(b) Linearity check

Position of the sensors remains the same. This test is performed by connecting a constant current source directly to the FMO magnetic field coils. A field up to and including ± 50 gamma is produced in 10 gamma steps. At each step the results should be printed out and appropriately

labeled. It may be necessary to return to a zero reference in between the 10 gamma steps if the earth's magnetic field is noisy on the day in question.

(c) Saturation check

This check can be made at any convenient time. It consists of running each fluxgate in earth's field in both the plus and minus direction to determine the positive and negative saturation levels. As in the other tests, the results should be printed out and properly documented.

(d) Polarity check

By using another fluxgate magnetometer whose polarity is known, one can determine the direction of the field within the coil system and hence ascertain the polarity of the spacecraft sensors.

2. Fluxgate Signal Processor

This test determines the minimum level at which the signal processor operates, and ascertains that the flux-maximum indication occurs at the proper time.

A sinusoidal current simulating spacecraft spin is fed from the flux-maximum panel to a coil placed over the fluxgate "A" sensor. The output from a Strobotac, which flashes on the optical aspect sensor, is sent to the flux-maximum panel. The signal level for operation of the fluxgate signal processor is monitored at the turn-on panel.

At the beginning of this test it would be advantageous to start with a signal level of 3 volts P-P and make sure everything is operating properly. Then the amplitude should be reduced to 0.5 volts P-P and gradually raised to 3 volts P-P in 0.5 volt P-P increments.

To determine whether the flux-maximum indication occurs at the proper time, a comparison is made in the time between the optical aspect pulse and the flux-maximum pulse in both the flux-maximum panel output and the telemetry output. This should correlate within 2 or 3 counts.

It is very important that the signals in the flux-maximum panel and the spacecraft be in phase. In other words, a positive field simulation from the current source in the flux-maximum panel should appear as a positive field to the fluxgate sensor.

3. Rubidium Vapor Magnetometer

The tests to be performed on the Rb magnetometer are: range, nulls, and bias sphere calibration

Sometime prior to these tests, the bias sphere and heat shield should be removed so that the Rb lamp can be heated to the proper operating temperature. These are not replaced until the bias sphere test is to be performed.

(a) Range test

For this test it is necessary that the spacecraft be oriented such that the Rb magnetometer, i.e., the spin axis, is at an angle of 45° with the horizontal, and aligned in the north-south direction. The entire fourth sequence should be printed out and appropriately labeled.

(b) Nulls test

For this test the payload is rotated about the east-west axis to determine how close to the null points the magnetometer will operate. Assuming the magnetometer tube is pointing directly north and designating this position as 0° , these null points would be 0° , 90° , and 180° . The magnetometer output is printed out and the angular position on each side of each null point at which the magnetometer signal "locks in" is recorded.

(c) Bias sphere calibration

The bias sphere must be replaced on the tube assembly for this test, and the payload oriented as in test 3(a). The entire fourth sequence should be printed out and labeled.

The following is a list of some of the equipment to be furnished by the integration personnel: portable de-com., turn-on panel, interrupter boxes (one for each type connector), flux-maximum panel, coils for fluxgate sensors with cables and connectors for flux-maximum panel, and equipment necessary for exciting the sun sensor. In addition all curves (period count to temperature, period count to fluxgate voltage or magnetic field) must be available. Also the experimenter requires the output of the fourth sequence from telemetry filtered sufficiently that it may be counted. The experimenter will furnish counter and printer for this output.

The following data should be provided for the experimenter:

1. All printouts properly labeled for all tests.
2. For the flux-maximum test the output counts from the telemetry and the flux-maximum panel must be in the same format so that comparison can be made.
3. Temperatures from PP-6 and PP-13.

"The aeronautical and space activities of the United States shall be conducted so as to contribute . . . to the expansion of human knowledge of phenomena in the atmosphere and space. The Administration shall provide for the widest practicable and appropriate dissemination of information concerning its activities and the results thereof."

—NATIONAL AERONAUTICS AND SPACE ACT OF 1958

NASA SCIENTIFIC AND TECHNICAL PUBLICATIONS

TECHNICAL REPORTS: Scientific and technical information considered important, complete, and a lasting contribution to existing knowledge.

TECHNICAL NOTES: Information less broad in scope but nevertheless of importance as a contribution to existing knowledge.

TECHNICAL MEMORANDUMS: Information receiving limited distribution because of preliminary data, security classification, or other reasons.

CONTRACTOR REPORTS: Technical information generated in connection with a NASA contract or grant and released under NASA auspices.

TECHNICAL TRANSLATIONS: Information published in a foreign language considered to merit NASA distribution in English.

TECHNICAL REPRINTS: Information derived from NASA activities and initially published in the form of journal articles.

SPECIAL PUBLICATIONS: Information derived from or of value to NASA activities but not necessarily reporting the results of individual NASA-programmed scientific efforts. Publications include conference proceedings, monographs, data compilations, handbooks, sourcebooks, and special bibliographies.

Details on the availability of these publications may be obtained from:

SCIENTIFIC AND TECHNICAL INFORMATION DIVISION
NATIONAL AERONAUTICS AND SPACE ADMINISTRATION
Washington, D.C. 20546