

X-520-66-107

55441

PRELIMINARY ANTENNA DESIGN CONSIDERATIONS FOR A STADAN RELAY SATELLITE SYSTEM

FACILITY FORM 602

N66-23469
(ACCESSION NUMBER)

38
(PAGES)

TMX
55441
(NASA CR OR TMX OR AD NUMBER)

(THRU)

(CODE)

31
(CATEGORY)

GPO PRICE \$ _____

CFSTI PRICE(S) \$ _____

Hard copy (HC) 2.00

Microfiche (MF) 1.50

BY

ff 653 July 85

W. F. GABRIEL

MARCH 1966



GODDARD SPACE FLIGHT CENTER
GREENBELT, MARYLAND

X-520-66-107

PRELIMINARY ANTENNA DESIGN CONSIDERATIONS
FOR A STADAN RELAY SATELLITE SYSTEM

by

W. F. Gabriel

March 1966

Goddard Space Flight Center
Greenbelt, Maryland

PRELIMINARY ANTENNA DESIGN CONSIDERATIONS FOR
A STADAN RELAY SATELLITE SYSTEM

W. F. Gabriel

Abstract

23469

A STADAN supplementary relay satellite system capable of direct two-way communication with instrumentation spacecraft is examined from an antenna system point of view. The required relay satellite antenna is of the simultaneous multiple-beam, wide-angle scanning, phased array type. Preliminary antenna design considerations indicate that such an antenna would be gain limited to approximately 30 db, and this gain limitation would not permit satisfactory operation with many present spacecraft which are typically of low radiated power. The concept becomes quite feasible in the 136 mc VHF band when spacecraft radiated power is increased to approximately 10 watts, and further system design-analysis for this band is recommended. Operation in the 400 mc band is also feasible for a spacecraft radiated power level of 10 or 20 watts, but the relay satellite antenna-receiver system becomes more complex and costly. S-band operation would be impractical for this general purpose concept because it would require the spacecraft to carry a moderately high-gain retrodirective antenna.

Author

CONTENTS

| | <u>Page</u> |
|--|-------------|
| Abstract | iii |
| I. INTRODUCTION | 1 |
| II. SOME RELAY SYSTEM CONSIDERATIONS | 1 |
| III. ANTENNA SYSTEM PARAMETERS | 5 |
| IV. SPACECRAFT TO RELAY SATELLITE LINK | 9 |
| IVa. 136 mc Relay Satellite Case | 10 |
| IVb. 400 mc Relay Satellite Case | 21 |
| IVc. S-Band Relay Satellite Case | 22 |
| IVd. Relay Satellite Antennas Above S-Band | 25 |
| V. GROUND STATION TO RELAY SATELLITE LINK | 26 |
| VI. CONCLUSIONS | 28 |
| References | 29 |

PRELIMINARY ANTENNA DESIGN CONSIDERATIONS FOR A STADAN RELAY SATELLITE SYSTEM

I. INTRODUCTION

Communication relay satellites placed in synchronous orbit are being considered by various groups for applications involving the relay transmission of voice, telemetry data, television, and tracking (or navigation) signals. One of these applications that is of interest to the Tracking and Data Systems group at Goddard is the use of synchronous satellites as a possible future supplement to the present global STADAN system. The interest stems from the fact that relay satellites can provide dependable channel links between all ground stations, thus permitting real-time communication between spacecraft and a single ground control center, with the consequent benefits of real-time mission control, data processing, etc. In addition, relay satellites can be designed with multiple beam, wide-angle scanning to obtain direct pathlinks with spacecraft, thus improving the spacecraft orbit coverage and eliminating possible "blind spots" that cannot be seen by ground stations. An ultimate objective would be to permit the STADAN to operate successfully either with fewer ground stations or simpler ground stations.

The purpose of this report is to present some preliminary antenna design considerations for the multiple beam, wide angle scanning relay satellite system concept, discussing the associated limitations and trade-offs involved. Attention has been directed toward the unmanned, instrumentation type of spacecraft ordinarily associated with the STADAN, although some of the analysis and comment applies equally well to manned spacecraft communications relay problems.

II. SOME RELAY SYSTEM CONSIDERATIONS

The geometry of a sample relay system based upon three ground stations and three synchronous satellites is shown in Figure 1. Each satellite is linked to two ground stations and vice versa such that the control center (CC) would have channel links with all three relay satellites and also the other ground stations. Thus, the control center would always have at least one communication link with any given spacecraft at all times, even for low altitude orbits where earth shadowing becomes a problem. Most of the time, a spacecraft would have contact with either two or all three of the relay satellites, which offers redundancy and affords good space diversity protection against possible interference from earth-reflected signals (multipath).

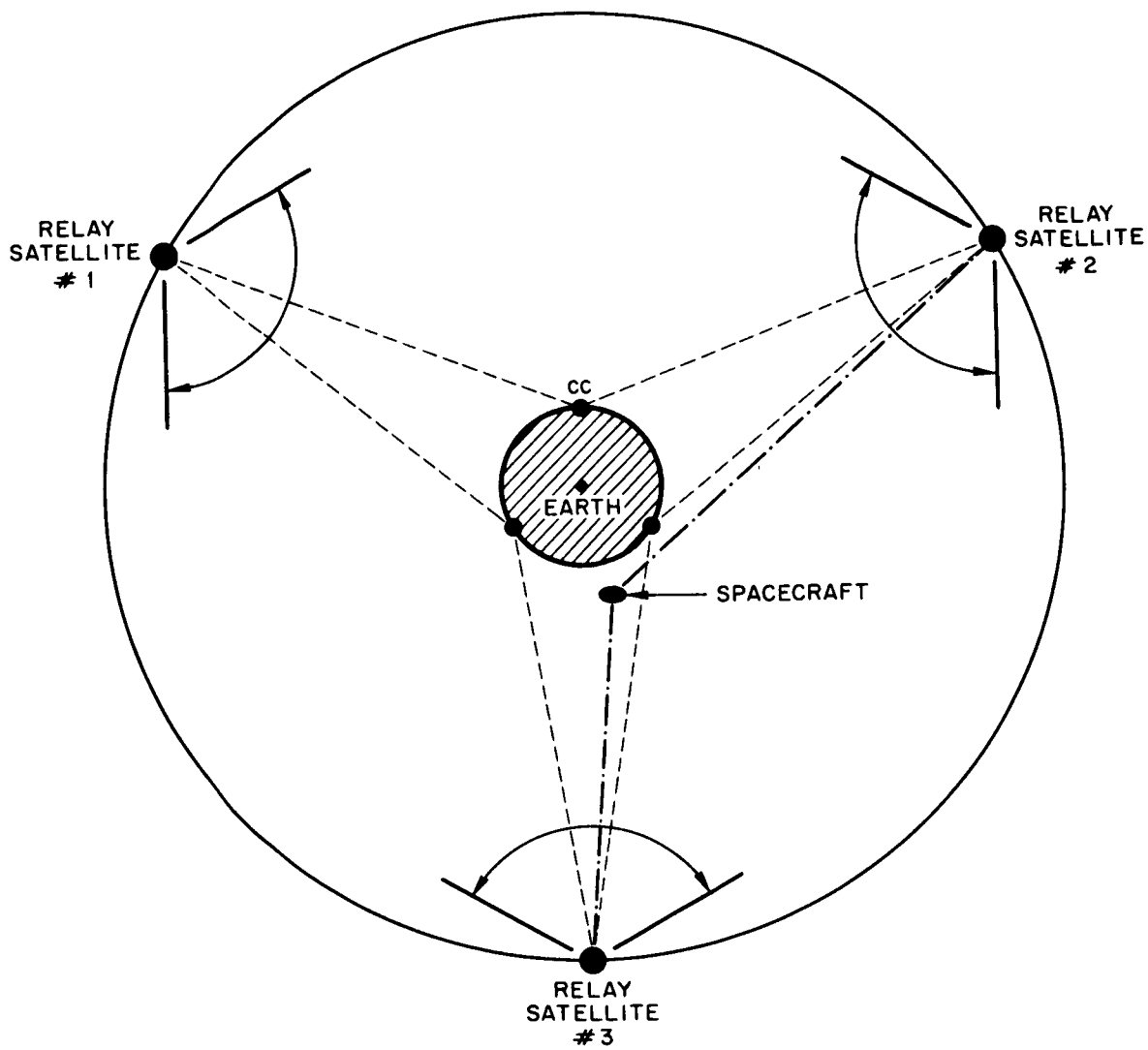

Figure 1-Relay Satellite System With Three Ground Stations

The length of service required of these satellites must be on the order of several years, so that it is assumed they would be either spin stabilized or gravity gradient stabilized, with an earth orientation sensing and drift correcting system.

Although present statistics are not a sure indication of the future, it is nevertheless of interest to examine the Stadan Projected Loading Study ¹ through 1970 in order to get an indication of orbits and frequency bands. Statistics derived from this document are listed in Table I and Table II for 116 spacecraft. This data shows that the great majority of spacecraft have orbits within the synchronous orbit altitude and transmit in the 136 mc frequency band, so that proposed system design should nominally favor the handling of spacecraft with these two characteristics. As it turns out, this choice is the most reasonable from the standpoint of feasibility, and it also is compatible with the concept of the relay satellites functioning as a supplement to the ground stations.

Table I

| Orbit Parameter Limit | Number of Spacecraft |
|-----------------------------------|----------------------|
| Perigee less than 22,000 miles | 108 |
| Apogee less than 22,000 miles | 91 |
| Synchronous Orbit | 4 |
| Perigee greater than 22,000 miles | 4 |
| Apogee greater than 22,000 miles | 21 |

Table II

| Frequency Band Utilized | Number of Spacecraft |
|----------------------------------|----------------------|
| VHF Band (136 megacycle typical) | 105 |
| UHF Band (400 megacycle typical) | 21 |
| S-band (1700 megacycle typical) | 4 |

Because of the orbit spread, the relay antenna system that provides two-way communication with several spacecraft simultaneously must be designed for a cone coverage of at least 120 degrees included angle; i.e., ± 60 degrees from the centered earth pointing direction (see Figure 1). The range is large enough that high-gain multiple-beam antennas must be used in which beam pointing can be accomplished by command control, using computed orbit predictions. Also, an automatic self-adapting mode of operation is desirable wherein the relay satellite automatically performs its own acquisition, hold, and retro-directive transmission whenever spacecraft signals hit it.

From a communication point of view, there are four fundamental limitations involved in such a relay system:

1. the RF transmit power of the spacecraft
2. the antenna gain of the spacecraft
3. the antenna gain of the relay satellite
4. noise.

Spacecraft that are presently in orbit or under development are designed for use with the present ground station high-gain antennas, so that they typically carry an omnidirectional unity gain antenna and a low transmitter power on the order of 1 watt or even less. This is highly desirable from the standpoint of keeping the spacecraft as simple as possible, but it obviously would require the relay satellite to have as much gain as the ground station antennas, and even more if the range is larger as in the case of low altitude orbits. In general, a relay satellite has a practical gain limitation which is lower than a ground based antenna, so that one may expect some difficulty in attempting to handle present spacecraft with their low gain-power products. Consequently, the concept of a STADAN supplementary relay satellite system is examined here from the standpoint of future spacecraft in which the gain-power product could be reasonably increased.

No attempt will be made to discuss the problem of tracking a spacecraft via a relay satellite for the following reasons:

- a. For the fixed orbits of typical instrumentation type spacecraft, tracking information in addition to that supplied by the ground stations would be highly redundant and unnecessary.
- b. It would be extremely difficult to implement accurate tracking angle information from an unmanned relay satellite space platform because of the dual problems of providing adequate platform stabilization orientation and accurate multiple-beam tracking.

- c. Because of antenna gain limitations on the relay satellite, it would be difficult to obtain sufficient signal-to-noise ratio and bandwidth to implement an accurate ranging scheme except for the special case where the tracked spacecraft carries a sufficiently high-gain antenna. Also, if the ranging scheme requires relaying of a coherent carrier, the receiver cost in a multiple-beam antenna system would probably become prohibitive.

In brief, then, accurate tracking is considered to be too much of a burden to place upon a multi-beam relay satellite, at least for the present state-of-the-art.

III. ANTENNA SYSTEM PARAMETERS

The antenna system parameters are related either directly or indirectly by the equation that defines received signal to noise ratio,

$$\left(\frac{S_0}{N_0} \right) = \frac{\left[\frac{P_t G_t G_r \lambda^2}{(4 \pi R)^2} \right]}{K T_0 B} \quad (1)$$

where (S_0/N_0) = receiver output signal to noise power ratio

P_t = transmitter power radiated

G_t = transmitter antenna gain

G_r = receiving antenna gain

λ = wavelength

R = range

K = Boltzmann Constant = 1.38×10^{-23}

T_0 = system operating noise temperature

B = receiver noise bandwidth

The most fundamental limiting quantity in equation (1) is the system operating noise temperature, T_0 , which may be written as,

$$T_0 = \left(\frac{T_a}{L_r} \right) + T_r + T_e \quad (2)$$

where T_a = noise temperature seen by the antenna
 L_r = receiver antenna network losses
 T_r = noise temperature contributed by network losses
 T_e = effective noise temperature of the receiver

Of these noise contributions, the antenna noise is the least predictable and, unfortunately, it is also the greatest offender for the most popular band of 136 mc. This is illustrated in Figure 2, which is a graph of cosmic noise versus frequency taken from a report by Krause and Ko.² The maximum curve would correspond to a beam pointed toward the galactic center, and the minimum curve would correspond to a beam pointed toward a galactic pole. If we assume an average galactic contribution represented by the "standard" curve in Figure 2, then our three frequencies listed in Table II would be affected as follows:

cosmic noise at 136 mc \approx 1400° Kelvin
 cosmic noise at 400 mc \approx 200° Kelvin
 cosmic noise at 1700 mc \approx 10° Kelvin

Some beams must necessarily point toward the earth and would see the earth temperature of approximately 290° Kelvin for all three frequencies. Contribution from the sun is generally negligible except for the beams that point toward it, in which case the noise temperature increases approximately by,

$$T_{as} = T_s \left(\frac{0.5}{\theta_a} \right)^2 \text{ for } \theta \geq 0.5 \text{ degrees} \quad (3)$$

where T_s = sun noise temperature $\approx 2.10^{14}/f$ Kelvin
 θ_a = antenna half-power beamwidth

It is possible for the sun to "noise jam" a beam that points toward it and this must be kept in mind in designing the system.

Low-noise preamplifiers will be required in large quantities, hundreds or thousands, so that weight and economy would become as important as the noise figure and would probably limit the choice to either transistor types or tunnel diode types. However, the superior noise performance of parametric amplifiers warrants careful evaluation of their use, in spite of the complications introduced by their pump requirements. For the present preliminary discussions, it is desirable to choose the more conservative approach and, therefore, transistor or tunnel diode types will be assumed. Taking present state-of-the-art receiver

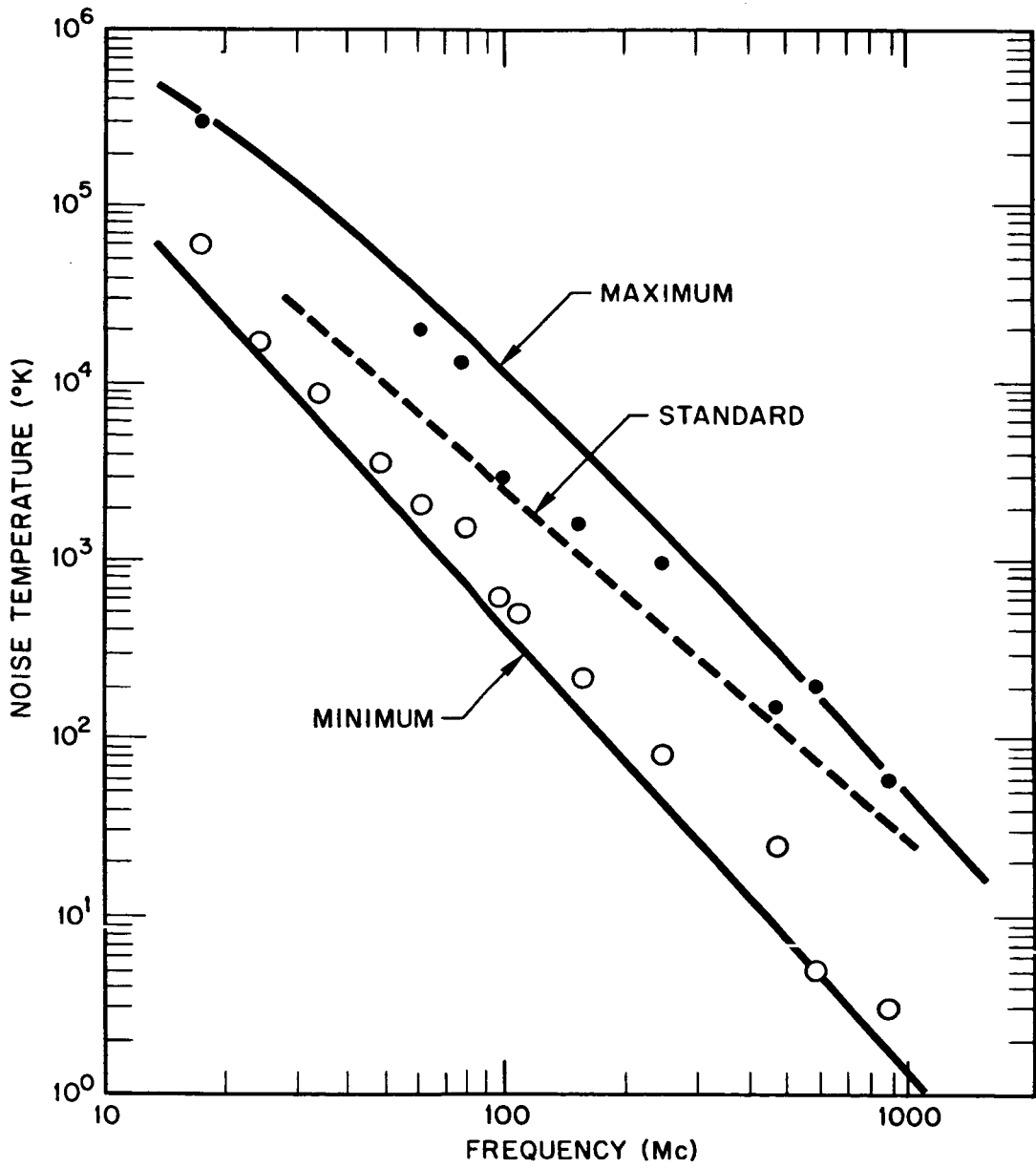

Figure 2-Cosmic Noise Temperature*

*Figure taken from report by J.K. Krause and H.C. Ko, see reference (2).

noise figures for the three frequency bands, a value of 4 db would be typical for good transistor preamplifiers at 136 mc and 400 mc, and tunnel diode preamplifiers at 1700-2300 mc. T_e would therefore be approximately

$$T_e = (F - 1) 290^\circ = (2.5 - 1) 290^\circ = 435^\circ \text{ Kelvin} \quad (4)$$

Neglecting network losses, the sum of the typical worst antenna noise temperature and the receiver noise temperature would be:

$$T_o = 1835^\circ \text{ Kelvin at 136 mc (cosmic plus 4 db receiver)}$$

$$T_o = 725^\circ \text{ Kelvin at 400 mc (earth plus 4 db receiver)}$$

$$T_o = 725^\circ \text{ Kelvin at 1700 mc (earth plus 4 db receiver)}$$

Doppler frequency shift constitutes another antenna system factor that must be kept in mind in designing the receivers, and it may be calculated from the equation,

$$\Delta f_d = \frac{\nu}{\lambda} \quad (5)$$

where ν = relative radial velocity.

For our three frequencies, a typical maximum radial velocity of 26,400 feet per second would result in the following doppler shifts,

$$\Delta f_d = 3.65 \text{ Kc at 136 mc}$$

$$\Delta f_d = 10.7 \text{ Kc at 400 mc}$$

$$\Delta f_d = 45.6 \text{ Kc at 1700 mc}$$

Since doppler shift will be both plus and minus, simple receiver bandwidths must be at least double these values as a minimum bandwidth requirement. It is possible to remove the doppler shift as a bandwidth factor by utilization of a frequency tracking scheme such as a phase-lock-loop, but this greatly increases the complexity and cost of a receiver and should be avoided in the relay satellite by deferring it to the ground station equipment if possible.

A brief look at the two different path-links involved in Figure 1 quickly points up the fact that the real problem is centered in the link between the spacecraft and the relay satellite, so that most of the discussion to follow will deal with this link.

IV. SPACECRAFT TO RELAY SATELLITE LINK

This link is characterized by the following factors:

- a. Wide-angle acquisition, hold, and tracking required on several spacecraft simultaneously by the relay satellite.
- b. Multiple frequencies and channels
- c. Doppler shift present
- d. No direct atmospheric effects, but ionospheric scintillations can occur for orbits below 400 miles altitude.
- e. Earth based RF interference probable
- f. Weight limitation
- g. Spacecraft power limitation
- h. Spacecraft antenna gain limitation
- i. Relay satellite antenna gain limitation
- j. RF field polarization variation
- k. Large dynamic range of signal amplitudes
- l. Multipath via earth reflections

A good starting point for this discussion is antenna gain. Equation (1) shows that signal-to-noise ratio and bandwidth are proportional to antenna gain, so that it is always desirable to have as much gain as possible both on the relay satellite and on the spacecraft. However, high-gain antennas plus their associated acquisition equipment become very expensive for space use, such that one generally settles for the minimum gain needed to do the job. In the particular case of instrumentation spacecraft operating in the VHF band, it is most economical and advantageous to employ a simple omnidirectional whip-turnstile antenna of unity gain so that the spacecraft will not be burdened with acquisition and beam pointing equipment. If we assume this unity gain antenna for the spacecraft, then all of the antenna gain, acquisition, and beam pointing burden is thrown upon the relay satellite. This VHF case is discussed in Section IVa to follow.

Section IVb treats the UHF band, section IVc discusses S-band, and Section IVd comments on frequencies above S-band.

IVa. 136 mc Relay Satellite Case

A consideration of the case where the spacecraft carries a unity gain antenna can be conveniently undertaken by plotting signal-to-noise ratio versus receiver noise bandwidth for various gain-power products. Upon substituting into Equation (1) a range of $R = 21,000$ nautical miles, a wavelength for 136 mc of $\lambda = 7.2$ feet, the system operating noise temperature of $T_o = 1800$ degrees Kelvin (cosmic noise plus 4 db receiver NF) found in Section III, and a polarization loss of 3 db, we obtain

$$\left(\frac{S_o}{N_o}\right) = 400 \left(\frac{P_t G_t G_r}{B}\right). \quad (6)$$

Equation (6) is shown plotted in Figure 3, where it is easy to see the effect of the gain-power product, $P_t G_t G_r$.

At 136 mc, it is difficult to conceive of an antenna aperture size on the relay satellite exceeding 5000 square feet on account of the severe construction and deployment problems involved with large physical sizes on satellites. If this assumption is valid, then from the antenna gain equation,

$$G = \eta \frac{4 \pi A}{\lambda^2} \quad (7)$$

where $\eta =$ antenna efficiency

$A =$ aperture area

it follows that a relay satellite would be gain limited to about $G_r = 30$ db maximum at 136 mc.

In addition, solar power requirements, weight, reliability, and cost make it unreasonable to push spacecraft RF power in excess of about 100 watts at the antenna terminals for typical spacecraft missions. If this assumption is valid, then we have a maximum $(P_t G_t G_r)$ product of about 50 dbw for the unity gain spacecraft and the relay satellite at 136 mc. The 50 dbw curve is the maximum curve plotted in Figure 3 and represents an approximate system performance limit.

Based upon present technology, it appears reasonable to design for system operation somewhere between the 30 dbw and 40 dbw curves in Figure 3. As a matter of interest, it will be noted that this region encompasses the proposed operating point for the ATS experiment on VHF aircraft communications.³

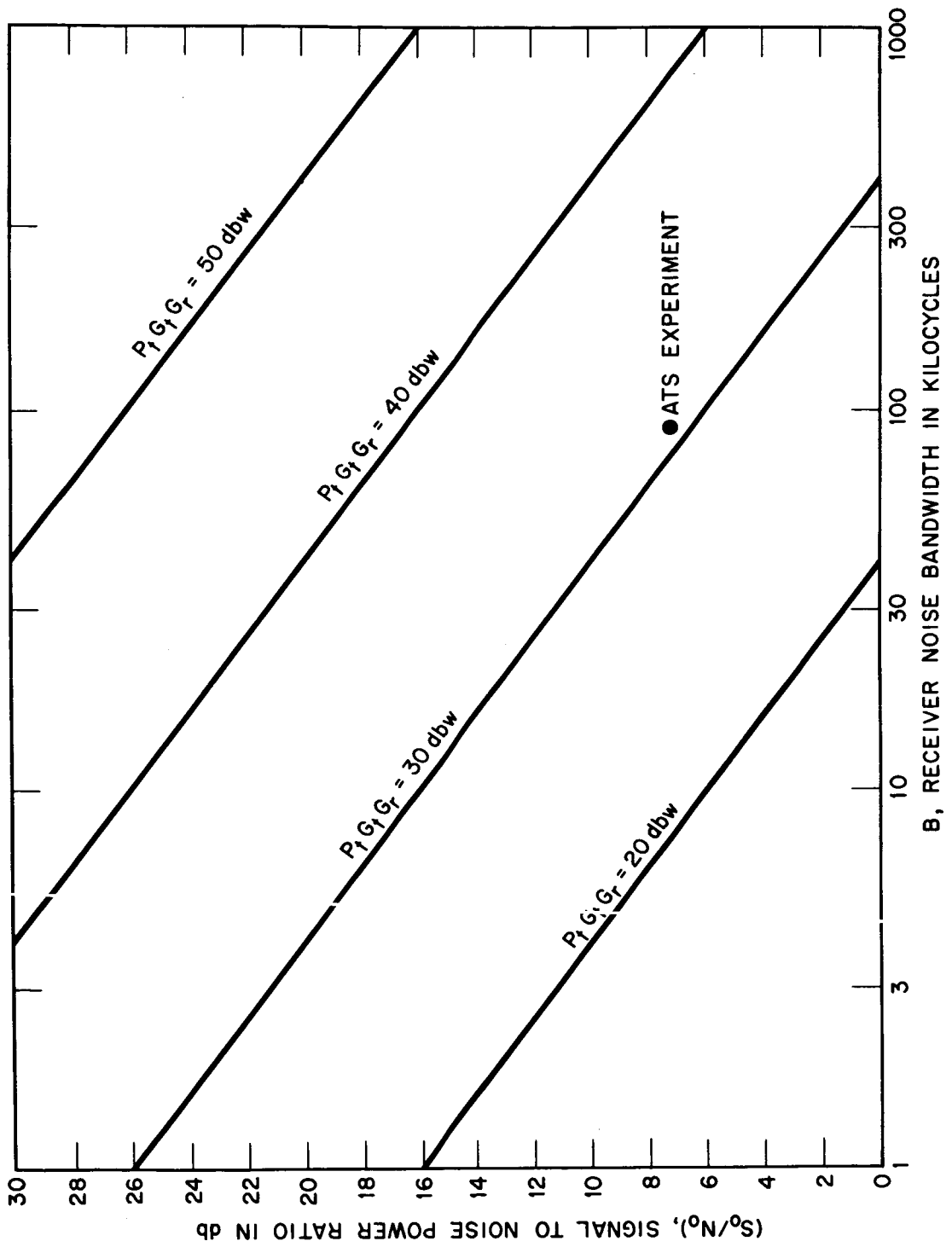
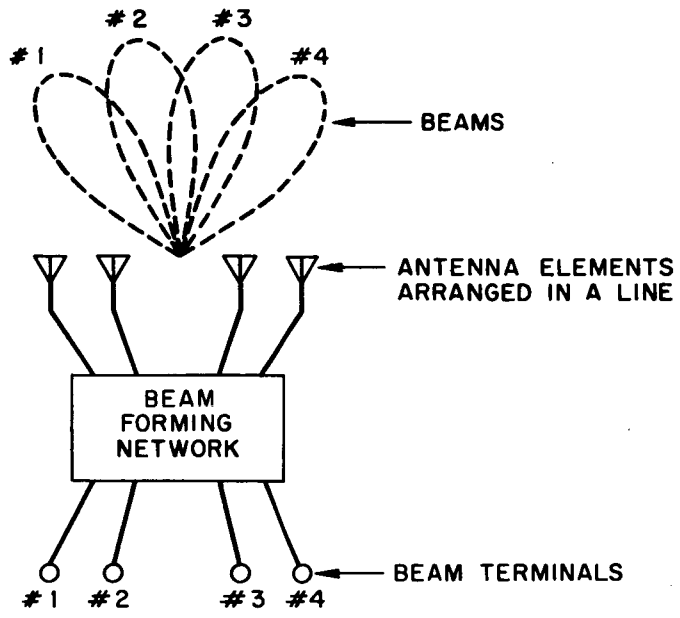

Figure 3—(S_0/N_0) vs. B at 136 mc

Assuming that the relay satellite receiver would be of the frequency-translation type, then channel bandwidth would be bounded on the low end by doppler shift of about 7 Kc, and on the high end by typical maximum channel bandwidths of about 100 Kc. This defines our design region in Figure 3 and shows that 100 Kc bandwidth operation would be characterized by (S_o/N_o) ratios of roughly 6 db to 16 db at maximum range. The lower limit of 6 db for the 30 dbw gain-power product may be somewhat marginal, since this would mean that roughly 20 percent of the relay satellite RF power transmission to ground would be wasted on the relay channel noise. However, this question will not be resolved here because the lowest practical (S_o/N_o) working limit is intimately tied to the particular receiver-transmitter technique employed on the relay satellite, and this topic deserves a separate, detailed analysis of its own as part of an overall communication link treatise.

Having defined a design goal region on the basis of Figure 3, the next step is to discuss appropriate antenna solutions. A very attractive multiple beam antenna solution for the VHF band is the phased hybrid matrix beam forming array. This type of multiple beam antenna lends itself to lightweight construction techniques and it can be designed either in planar form^{4,5,6,7,8} for use with gravity gradient stabilization, or in cylindrical form^{9,10,11} for use with spin stabilization. It should be noted that References 10 and 11 discuss a 4π steradians coverage antenna, sponsored by NASA Goddard Space Flight Center, which utilizes both the planar array and the cylindrical array in combination. Since the theory of operation of these arrays is well covered in the listed references, it will not be repeated here, but for the unfamiliar reader a simple block diagram of the antenna arrangement is shown in Figure 4. The basic points to note are: that the beam forming network provides a separate terminal for each individual beam; each beam has the full gain of the array; and the beams overlap to provide continuous coverage in space over the solid angle sector for which the array is designed. The beam forming network is entirely passive and consists of hybrid junctions, fixed phase shifters, and transmission line.

A cylindrical array form intended for spin stabilization with the spin axis perpendicular to the synchronous orbit plane is depicted in Figure 5. This cylindrical array is based upon a 16 element circular array multiplied by an 8 element linear array, resulting in a total of 128 elements on the cylinder. As shown in Figure 5, at 136 mc it would have a diameter of about 18 feet and a height of about 30 feet, resulting in a possible effective aperture area of 540 square feet and a gain of about 20 db. (Note that this amount of gain would require a minimum spacecraft radiated power of 10 watts in order to achieve the 30 dbw curve in Figure 3.) Characteristics of this cylindrical array are as follows.



a) LINEAR ARRAY

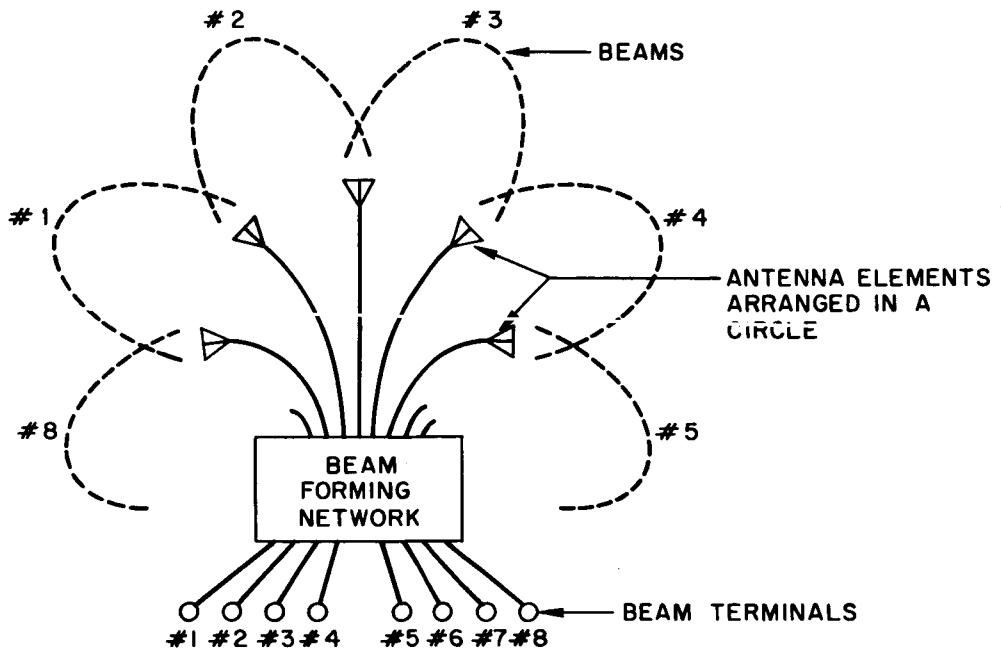

b) CIRCULAR ARRAY

Figure 4—Simple Representation of Phased Hybrid Matrix Arrays

- a. gain - approximately 20 db
- b. beamwidth - approximately $18^\circ \times 22\text{-}1/2^\circ$
- c. Number of beams - 16×8 or 128 total basic beams. Auxiliary circuits can implement beam combining to increase the total to 450 beams in order to hold beam cross-over gain drop to less than 2 db.
- d. High-gain angular coverage - almost omnidirectional, there being two "low gain" cones of about 45° included angle aligned with the spin axis of the relay satellite.

Although this antenna is of considerable size, the VHF band is very amenable to unfolding and unfurlable deployment techniques that could reduce the launch size, if necessary. The large cylindrical outer surface could readily accommodate additional higher frequency array antennas and, also, the usual solar cell panels. In order to achieve maximum gain, low noise receive performance, and "graceful death" failure performance of the transmit power stages, it would probably be necessary for each antenna element to connect into a module consisting of a transmit transistor RF power amplifier, a low-noise transistor receiver preamplifier, and the necessary diplexer filters. These modules would then connect into the beam forming network.

A possible arrangement for the relay satellite receive-transmit system is shown in Figure 6, which is based upon the possibility of being able to select any particular beam for any channel in the VHF band, with all channels operating simultaneously and, of course, simultaneous transmit and receive. Two modes of operation are employed here: a command mode in which ground control signals operate the beam switching for any or all channels, and an automatic mode in which the receiver automatically switches to the strongest beam ("greatest of" selection) for each channel. The automatic mode would constitute a "self adapting" system since it automatically performs acquisition, hold, and retro-directive transmission whenever spacecraft signals above threshold hit it.

There are a number of ways in which the automatic mode of operation can be achieved, and Figure 7 illustrates one of these arrangements. The outputs from the various beam ports are mixed down to a suitable IF, amplified, and separated into particular channels by a filter bank, corresponding to the various active spacecraft. Figure 7 shows the detail block diagram for the F_5 channel on beam 1R. Since a strong spacecraft signal could be present in several beams (both main lobes and sidelobes) it is extremely important that the receiver adapt itself automatically to the strongest beam. Figure 7 illustrates one means for doing this "greatest of" selection; by means of a floating AGC bus that becomes biased by the strongest AGC signal. The strongest signal feeds the bus thru a diode, and the resultant current creates a voltage difference across the input of

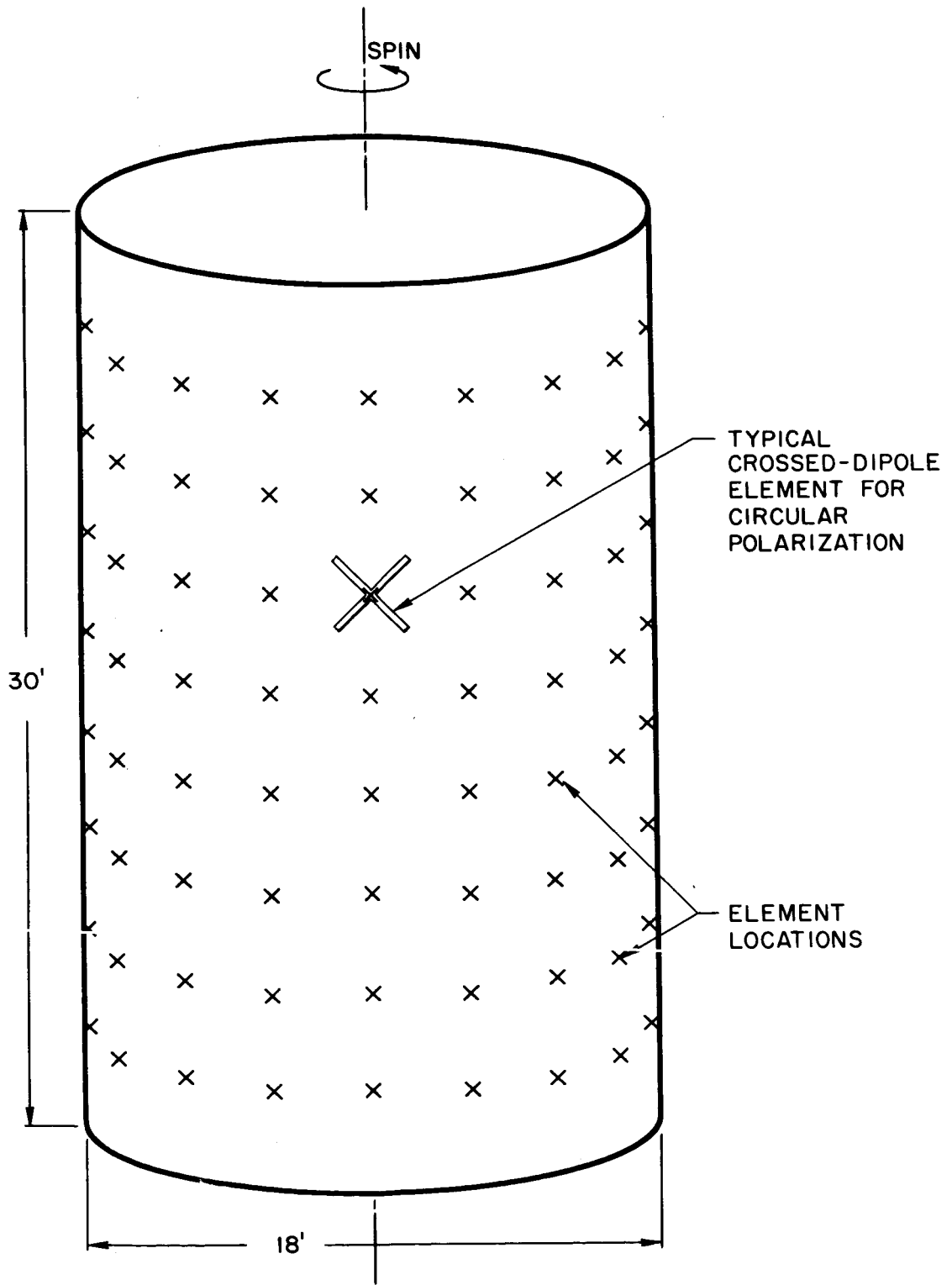

Figure 5-136 mc Cylindrical Hybrid Matrix Phased Array for Spin Stabilization

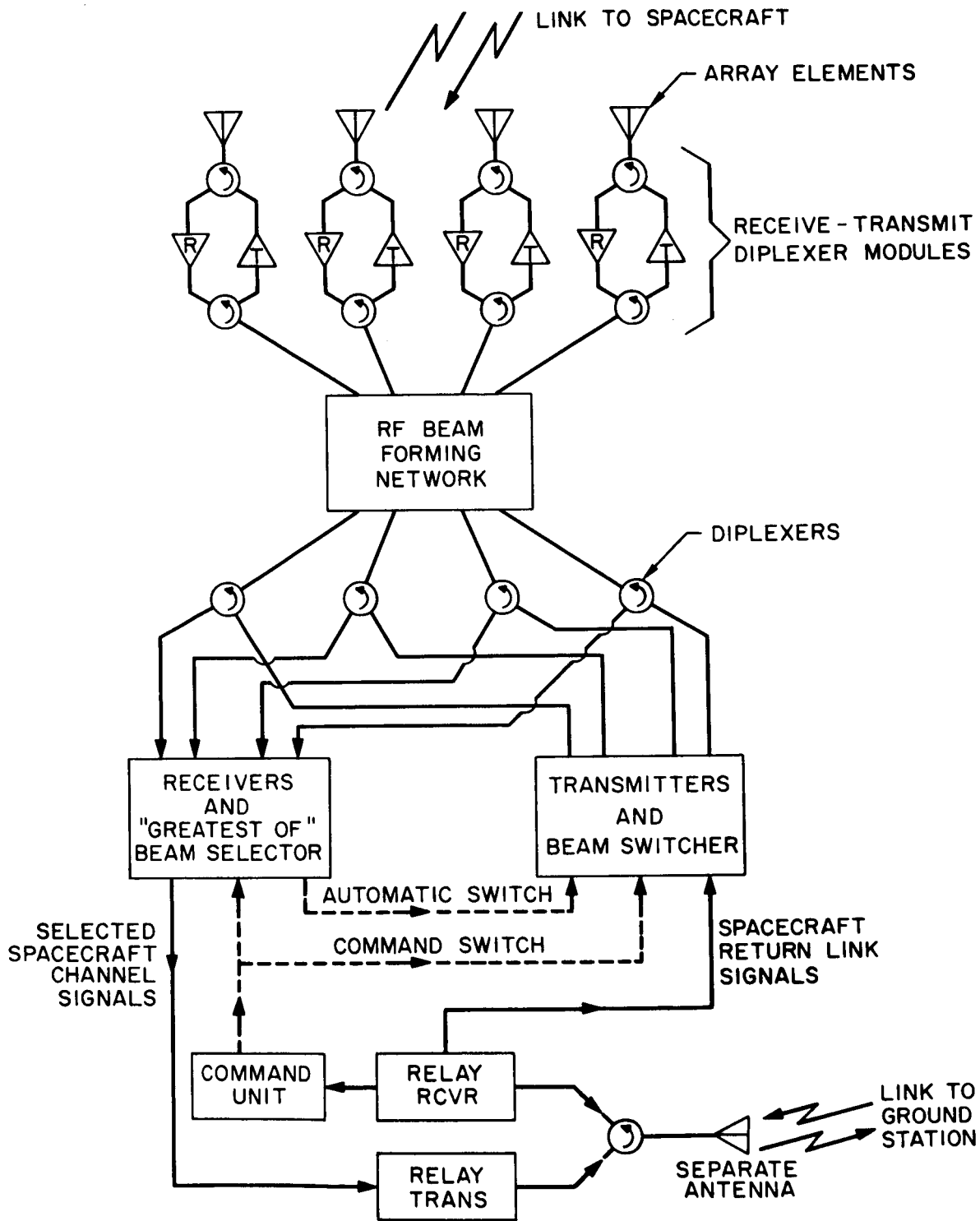

Figure 6-Simple Block Diagram of Relay Satellite Receive-Transmit System

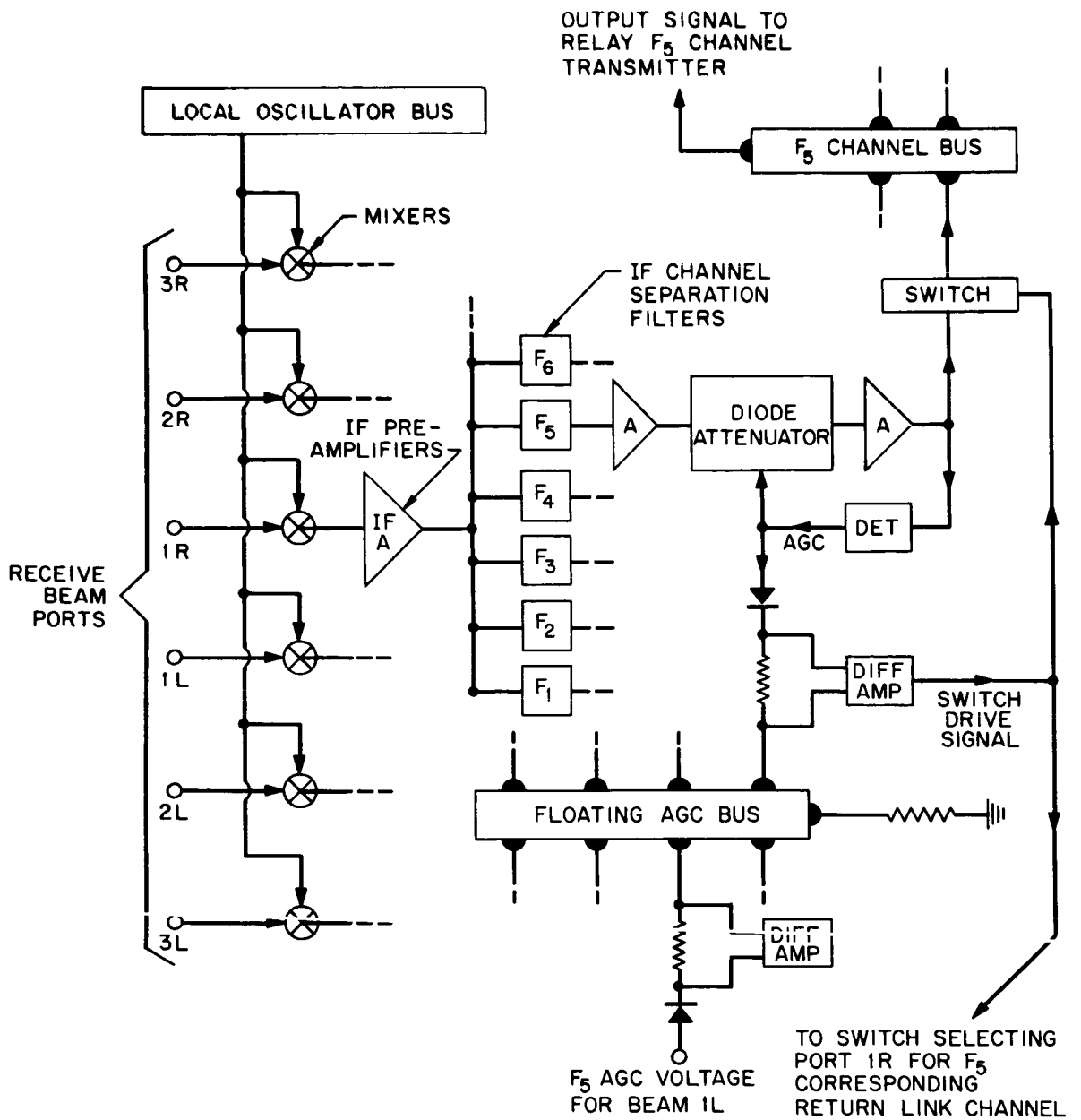

Figure 7—Automatic Multiple Channel Receiver

a differential amplifier. The differential amplifier output then drives two switches; one of which connects the strongest beam channel into a channel bus that feeds the Relay output transmitter for the ground link, and the other of which connects the corresponding 148 mc return link channel to the transmit beam port identical to the strong receive port. In this manner, the array automatically adapts itself to keep a given two-way link open. The problem of automatic handover from one beam to the next can also be handled by this receiver, provided the phase lengths of the receiver channels are kept equal. The cross-over between two beams results in equal AGC signal such that both differential amplifiers trip their switches and connect both beams into the same channel but, if the phase lengths are equal, this merely results in a "cosine taper" beam centered between the two ($\sin\theta/\theta$) beams. Thus, beam cross-over could be smooth and almost unnoticeable.

The receiver of Figure 7 is intended to be a "frequency translation" receiver; i.e., the signal from the spacecraft is not demodulated and then re-modulated for the groundlink transmission, but is simply translated in frequency to the ground-link RF band by mixing the amplified I.F. signal with an appropriate RF carrier. This simplifies the relay satellite receiver system and defers the more expensive demodulation receivers to the ground-based end of the system.

Spin stabilization of this cylindrical array requires a counter de-spinning of the multiple beams, but this should not present a problem for the receiver sketched in Figure 6. Beam despin would be handled in the automatic mode as a normal functioning of the "greatest of" beam selection, and in the command mode it would be handled by introducing computed de-spin beam switching command signals.

If gravity gradient stabilization proves to be practical at synchronous orbit altitude, then a planar array can be utilized which is somewhat simpler in implementation than the cylindrical array discussed above. Figure 8 illustrates an 8×8 element planar array (64 elements total) at 136 mc which would measure about 30×30 feet, resulting in a possible effective aperture area of 900 sq ft at broadside. Aperture area decreases as the cosine of the scan angle off broadside for a planar array, so that if we wish to scan off broadside by about ± 60 degrees as required in the Figure 1 system configuration, then aperture would decrease to about 450 sq ft at the scan limits or a gain of about 20 db. The total number of basic beams would be 64, which is exactly half the number required for the cylindrical array.

The receive-transmit system could be the same as that shown in Figure 6, although the planar array beam forming network is so simple that it might be desirable to utilize separate networks for transmit and receive in order to ease the diplexing problem. Figure 9 is intended to illustrate the simplified diplexing made possible by using separate networks (only one row of 8 elements is shown).

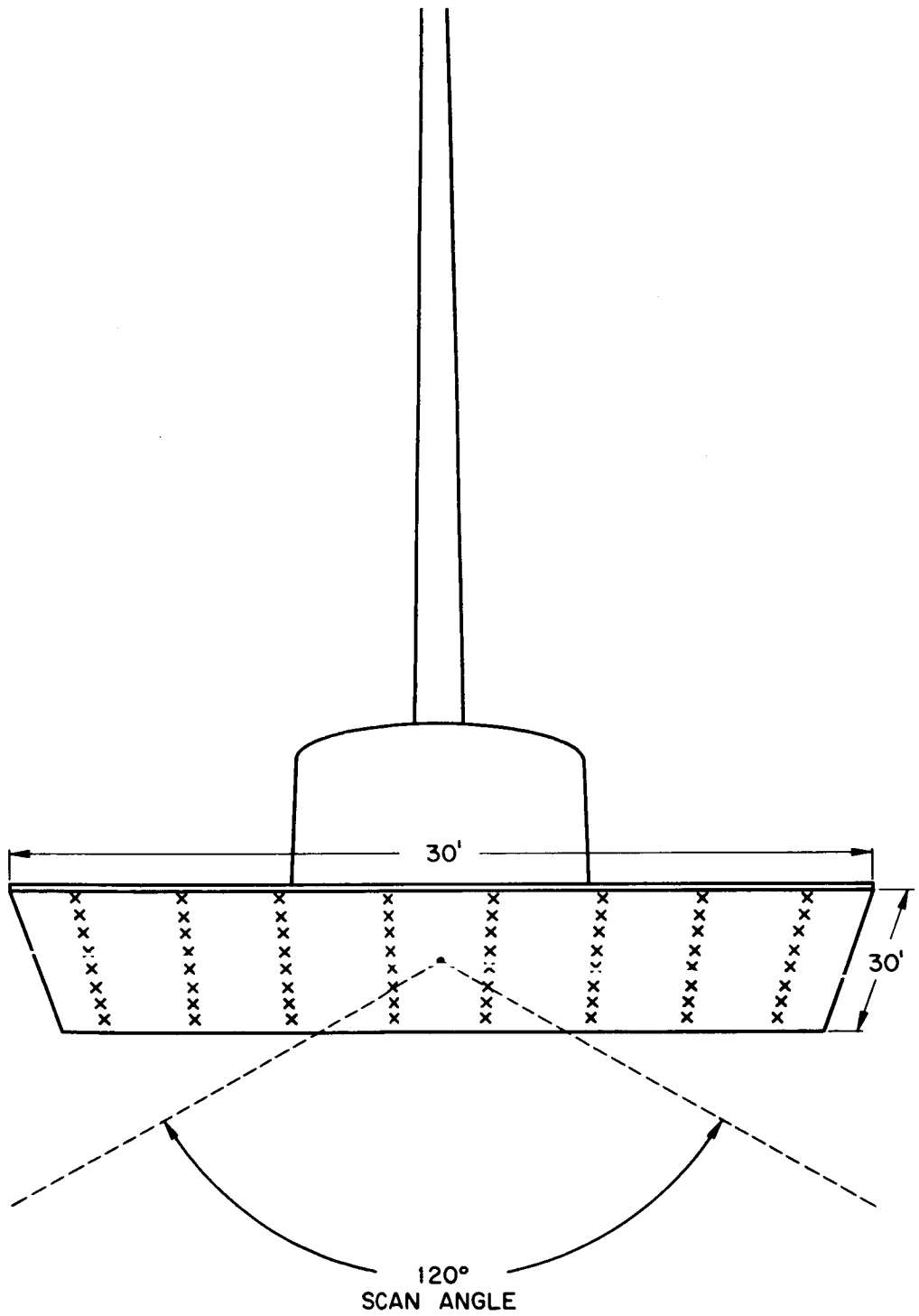

Figure 8-136 mc Planar Hybrid Matrix Phased Array for Gravity Gradient Stabilization

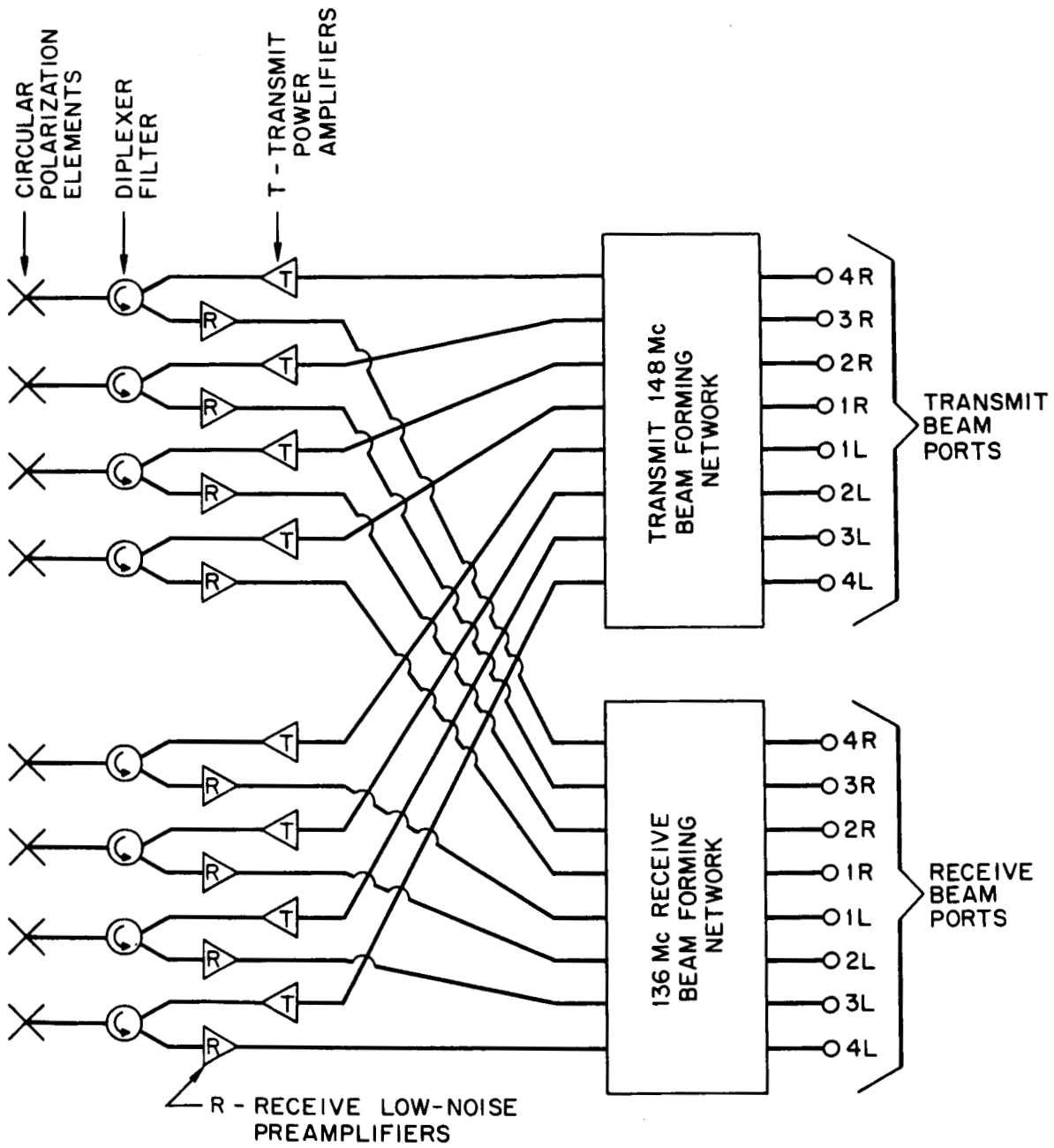

Figure 9-Diplexing Arrangement with Separate Beam Forming Networks

The automatic receiver arrangement of Figure 7 applies to the planar array the same as it did to the cylindrical array and, in fact, would be better because only half as many beams are needed and there is no beam despinning involved.

In comparing the two types of arrays, one should not overlook the fact that the cylindrical array has almost omnidirectional scan coverage and, therefore, is better able to handle spacecraft orbits that exceed synchronous orbit altitude, if that should become desirable.

IVb. 400 mc Relay Satellite Case

Increasing the frequency to 400 mc results in some advantages and disadvantages. In Section III it was shown that cosmic noise drops to a reasonable value such that the worst antenna-receiver noise temperature drops to about $T_0 = 725$ degrees Kelvin (earth temperature plus 4 db receiver NF). Substituting this into equation (1) together with $\lambda = 2.46$ feet, $R = 21,000$ nautical miles, and a polarization loss of 3 db results in

$$\left(\frac{S_o}{N_o}\right) = 118 \left(\frac{P_t G_t G_r}{B}\right) \quad (8)$$

Comparing this against Equation (6) for the 136 mc case, we see that our multiplying constant is smaller by a factor of four, so that a larger gain-power product is needed in order to obtain the same bandwidth. Equation (8) is shown plotted in Figure 10. In addition to the decrease in the multiplying factor, the 400 mc channels are typically wider in bandwidth than at 136 mc, going up to 300 kilocycles, so that we now need a $P_t G_t G_r$ product about 11 db higher than at 136 mc.

The higher gain-power product is difficult to achieve from increased spacecraft transmitter power because transmitter problems are even worse at 400 mc than they are at 136 mc, so that a practical upper limit of about 100 watts would still apply on a system basis. Thus, if a unity gain antenna is to be used on the spacecraft, then most of the 11 db increase should appear as increased antenna gain on the relay satellite, which would necessitate a total gain on the order of $G_r = 31$ db. From Equation (7) it will be found that this amount of gain requires an antenna aperture size of about 750 square feet for an efficient array, and scanning loss would increase that to 1500 square feet for a planar array, which amounts to a diameter of some 44 feet.

Such a large array antenna is technically feasible at 400 mc, but the implementation for space use is severe. For instance, with elements spaced by $\lambda/2$

on centers, it would require about 1000 elements, and the sheer magnitude of this number of required low noise preamps, power stages, diplexers, etc., would result in an uncomfortably high cost and weight for the relay satellite. Thus, for multibeam array antennas, there is a practical "numbers limit" in an application such as this, and it is probably reasonable to assume that a magnitude of 1000 elements is about the top design limit that could be tolerated.

As soon as one chooses a limit for the number of elements, then a gain limit independent of frequency is set because array gain is equal to

$$\text{(broadside) } G_r \approx \pi \eta N \quad (9)$$

where η is the array efficiency and N is the number of elements spaced $\lambda/2$ on centers. (Note that if we substitute 1000 elements, an array efficiency of 80 percent, and reduce the result by 3 db to account for scanning loss, then our gain limit is roughly 31 db for G_r , which checks with the initial value used.) Referring to Figure 10, this gain limit would, in turn, require a spacecraft radiated power level of about 10 watts in order to get a minimum (S_o/N_o) of 6 db at a 300 Kc channel bandwidth, so that the unity gain spacecraft antenna concept is still feasible at 400 mc, although the relay satellite antenna-receiver system would be about ten times more complex and costly than the 136 mc system as described in the preceding section.

IVc. S-Band Relay Satellite Case

Increasing the frequency to S-band forces complete abandoning of the spacecraft unity gain concept because doppler shift is now consuming about 100 Kc of bandwidth, typical channel bandwidths are 1 mc or even higher, and the range-wavelength loss has increased by more than an order of magnitude. At 1700 mc equation (1) becomes

$$\left(\frac{S_o}{N_o}\right) = 6.5 \left(\frac{P_t G_t G_r}{B}\right), \quad (10)$$

where it is evident that a gain-power product of at least 60 dbw is required. Equation (10) is shown plotted in Figure 11.

S-band frequencies are still low enough that array techniques are preferable to optical analogue techniques for multiple beam antennas on satellites, so that the array discussions in the preceding sections would still apply. An S-band relay satellite antenna would therefore be gain limited to approximately the

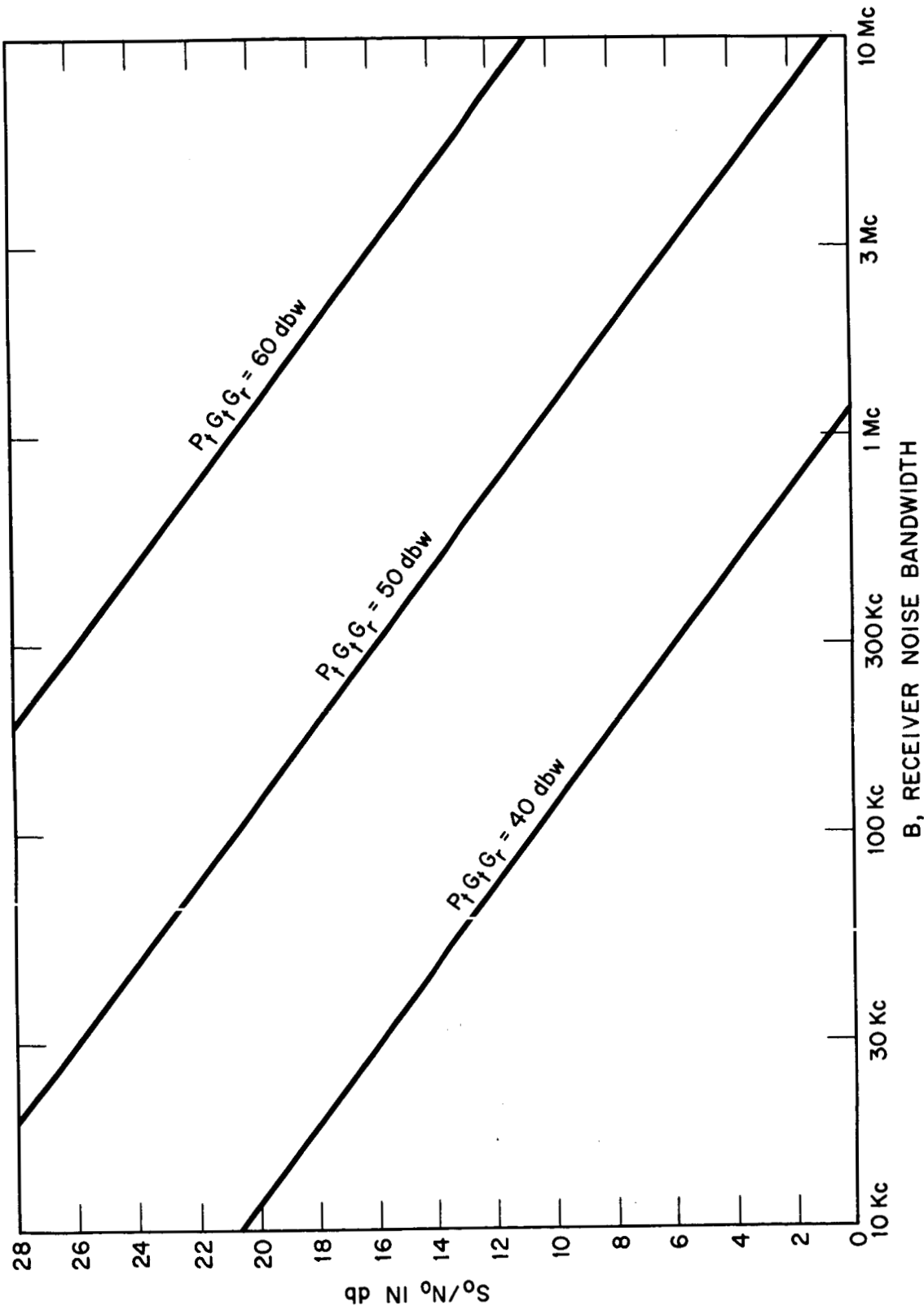

Figure 10—(S_0/N_0) vs. B at 400 mc

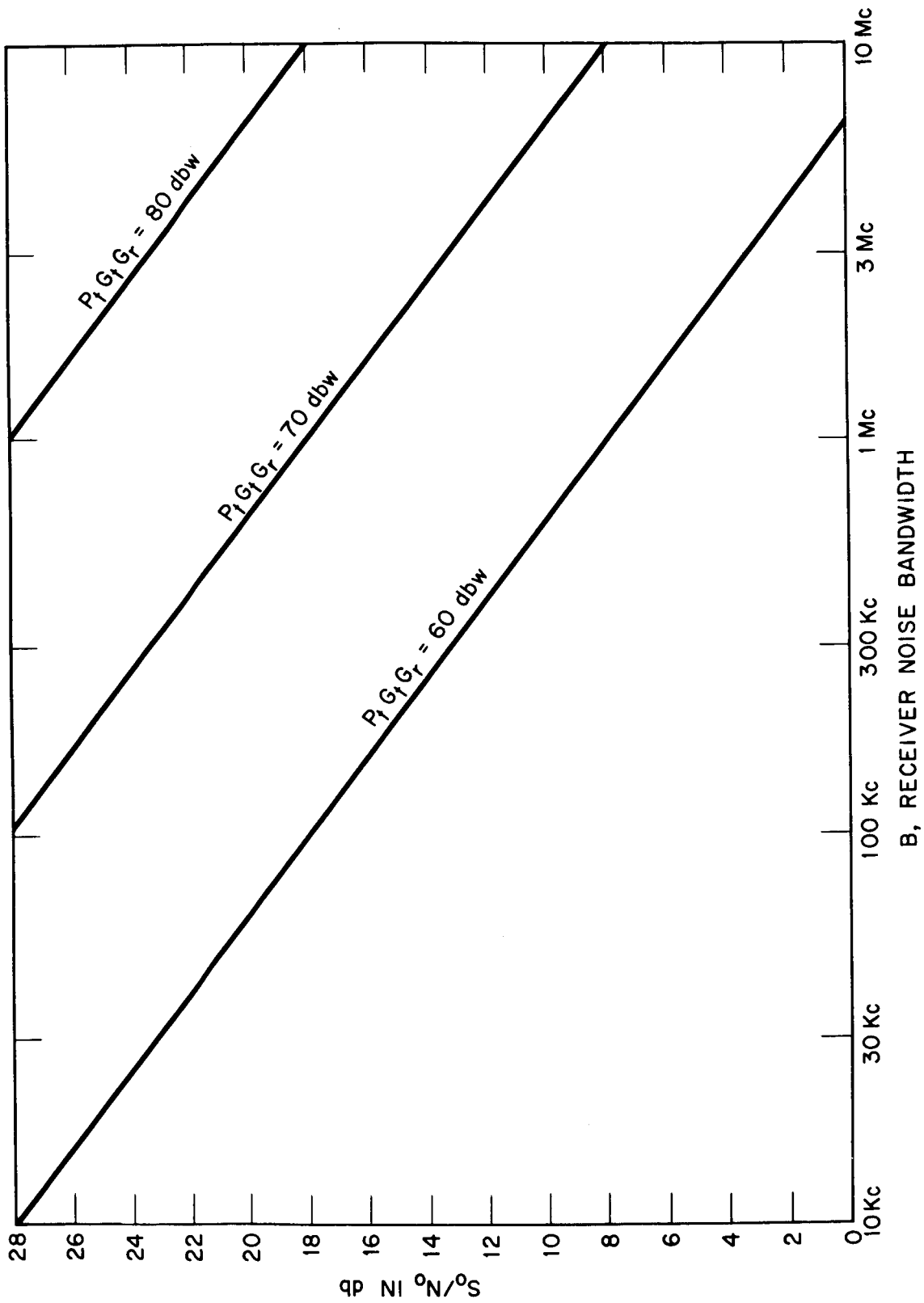

Figure 11 - (S_o/N_o) vs. B at 1700 mc

same 30 db for the reasons cited, the only difference being that its aperture size is now much smaller, being on the order of 85 square feet.

If one assumes the same spacecraft transmit power limitation of about 100 watts, then a spacecraft antenna gain in the range of 10 db to 20 db is indicated, and this complication would tend to make the relay system impractical for general purpose spacecraft use at S-band. However, it is worthwhile noting that if these were special purpose spacecraft missions where spacecraft gain was justified, then S-band could actually be preferable to a lower frequency because of the smaller antenna sizes involved for the same bandwidth. This point will be pursued further in the following section IVd.

IVd. Relay Satellite Antennas Above S-Band

At frequencies above S-band, phased array antenna techniques become increasingly complex, difficult, and expensive to implement, whereas optical analogue antenna techniques become increasingly simple. Thus, reflectors and lenses take over, gain is easily achieved with reasonable size apertures, and it actually becomes realistic to manipulate Equation (1) into the following form,

$$B = \frac{P_t A_t A_r f^2}{c^2 K T_0 (S_o/N_o) R^2} \quad (11)$$

where f = RF carrier frequency
 c = velocity of light
 A_t = transmit antenna effective aperture area
 A_r = receive antenna effective aperture area

and the other quantities are the same as defined previously for Equation (1). This equation clearly shows that for given size antenna apertures and other factors remaining equal, communication bandwidth can be increased as the square of the carrier frequency. This fundamental relationship forms the basis for the intense interest and study efforts that are presently being devoted to millimeter waves and optical frequencies (laser systems) for space communications.

Of course, these extremely high frequencies are not without their problems. For example, it is soon recognized that acquisition and tracking become increasingly difficult as the frequency goes up because the associated beamwidths get smaller and smaller; spacecraft stabilization requirements become severe; doppler shift becomes excessive and requires removal; and transmitters and

receivers generally have poor performance characteristics. Research and development efforts in these problem areas have not as yet produced solutions that would be satisfactory for the relay satellite system envisioned here as a STADAN supplement. However, progress is rapid and will probably produce significant results within the next 5 year time span, so that frequencies above S-band must be periodically reviewed for application.

The narrow pencil beam, high-gain, optical-analogue techniques are better suited to single link operation than multiple link. As an example, Figure 12 depicts a self-adapting configuration based upon a high-gain dish being slaved to null on a broadbeam acquisition interferometer signal, thereby aligning its bore-sight close enough to permit lock-on with its own tracking feed. In order to initially acquire the signal, the interferometer must have a narrow-band, phase-lock-loop receiver that can search, acquire, and track the doppler shifts. The mechanical positioning is undesirable, of course, and may require counter-acting torques in the space platform, but it has the advantage of far less weight and cost than a fully electronic steering system. In order to handle several spacecraft, it would be necessary to have multiple replicas mounted on the space platform.

V. GROUND STATION TO RELAY SATELLITE LINK

This link must perform two functions; it must provide a two-way communications link between ground stations in the usual Comsat manner, and it also must provide a two-way communications link between the spacecraft channels and the ground stations. The link is characterized by the following factors:

- a. Essentially fixed antenna orientation, no scanning
- b. No doppler shift
- c. Wide bandwidth to accommodate many channels
- d. Atmospheric noise, attenuation, and scintillation, plus ionospheric scintillation.
- e. Occasional rainy weather operation
- f. Probable man-made interference signals
- g. High performance ground antenna-receiver

Either S-band or C-band is a good choice for the frequency band of this particular link because of the strong influence of atmospheric effects and the need for wide bandwidth to accommodate many channels.

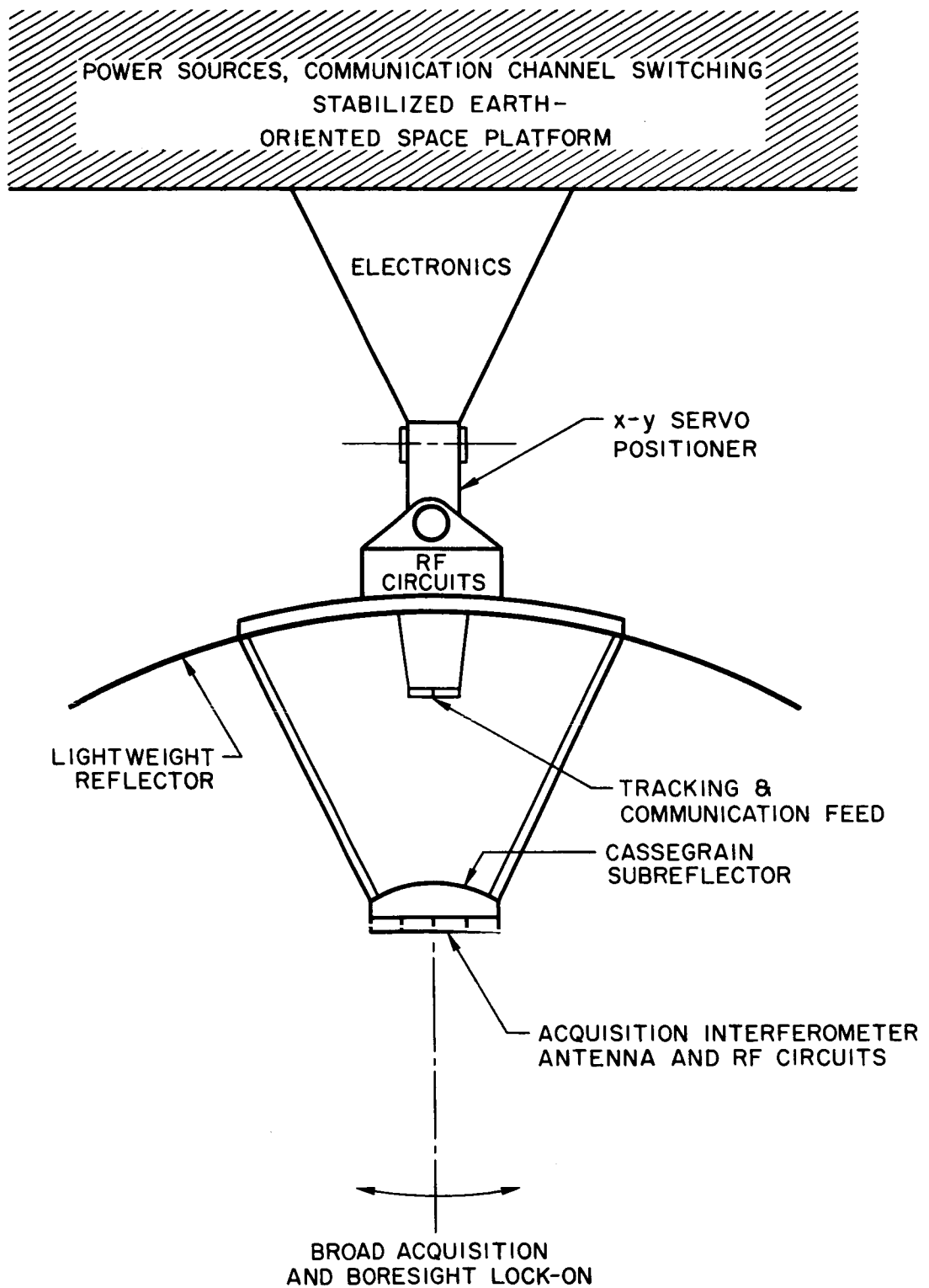

Figure 12—Self-Adapting Single Link Antenna

NASA already has good 30 foot, 40 foot, and 85 foot precision tracking antennas for the ground station end of the link, together with high power transmitters and good low-noise receivers. With such high performance obtainable on the ground station end of the link, the relay satellite end antenna requirements are very modest and could consist of a small array with a beamwidth of about 20 degrees (to cover the earth) and a gain of about 18 db. Gain-power products of 80 dbw at S-band are readily realized for achieving very wide bandwidths.

The major problem for this link is how to handle the multitude of channels involved, and it deserves separate treatment as part of an overall communication link analysis.

VI. CONCLUSIONS

The foregoing preliminary antenna design considerations for a STADAN multiple beam, wide-angle scanning relay satellite system lead to the following conclusions:

- a. The practical gain limitations of relay satellite multi-beam antennas would not permit this concept to be applied as a general purpose relay station which could be utilized for the typical spacecraft of today. Present spacecraft gain-power products are too low.
- b. By raising spacecraft radiated power into the range of about 10 or 20 watts, then the concept becomes quite feasible in the 136 mc VHF band, utilizing an omnidirectional unity-gain spacecraft antenna. A very attractive solution for the relay satellite high-gain antenna is the phased hybrid matrix beam forming array, which can be designed either in cylindrical form for spin stabilization or in planar form for gravity gradient stabilization, with dimensions on the order of 30 feet.
- c. At 400 mc a spacecraft radiated power level of 10 or 20 watts would still be feasible for system operation, but the relay satellite array antenna is pushed to a practical gain limitation due to "numbers of components" involved. Implementation of the antenna-receiver system at 400 mc would be at least ten times more costly than at 136 mc.
- d. At S-band, the relay satellite gain limitation forces abandonment of an omnidirectional unity-gain spacecraft antenna. The spacecraft would have to have antenna gain, with its associated acquisition and beam pointing complexity, together with a moderate transmitter power.

Therefore, the most practical operating band for this particular relay satellite concept is the 136 mc VHF band. Assuming continued heavy utilization of

this band for future spacecraft transmissions, it appears worthwhile to pursue the concept further into a detailed system design-analysis and an associated weight-cost estimate. An interesting sidelight is that the relay satellite required for this job would also be well suited, with minor modifications, for handling several other VHF communications link jobs such as military field communications, military and civilian aircraft communications, etc., so that a possibility for cooperation and cost sharing exists. In addition, if there is sufficient interest in the concept, it would appear desirable to utilize the ATS series of satellites for conducting some preliminary performance evaluation tests. The concept has several points in common with the aircraft VHF communication experiment that will be conducted as part of the ATS program.³

ACKNOWLEDGMENT

The author wishes to acknowledge helpful discussions held on this topic with Dr. R. J. Coates, J. Purcell, T. S. Golden, and others at Goddard Space Flight Center.

References

1. "Stadan Projected Loading Study, July 1965 thru December 1970," Goddard Space Flight Center, I-535-65-126.
2. J. Krause & H. C. Ko, "Celestial Radio Radiation," Contract AF19(604)-1591, Ohio State University, RF Project 673, Scientific Report No. 1, May 1957.
3. David W. Lipke, "Advanced Technological Satellite Experimental Communications System Description and Requirements," Goddard Space Flight Center - S11-012, 15 November 1965.
4. J. L. Allen, et al, "Phased Array Radar Studies," Lincoln Lab. M.I.T. Tech. Rept. No. 228, pp. 217-230, August 1960; Astia 249470, H-335.
5. J. P. Shelton and K. S. Kelleher, "Multiple Beams from Linear Arrays," IEEE Trans. on Ant. & Prop., Vol AP-9, pp. 154-161, March 1961.
6. J. L. Allen, et al, "Phased Array Radar Studies," Lincoln Lab. M.I.T. Tech Rept. No. 236, pp. 19-53, November 1961.
7. W. P. Delaney, "An RF Multiple Beam Forming Technique," Lincoln Lab. M.I.T. Tech. Rept. No. 41-G-0012, Contract AF19(604)-7400, August, 1961; Astia 262017, H-334.

8. C. A. Belfi, et al, "A Satellite Data Transmission Antenna," IEEE Trans. on Ant. & Prop., Vol AP-12, No. 2 pp. 200-206, March 1964.
9. G. G. Chadwick, J. C. Glass, "Investigation of a Multiple-Beam Scanning Circular Array," Scientific Report No. 1, AFCRL Contract No. AF19(628) 367, December 1962; Astia 411868.
10. G. G. Chadwick, et al, "A High-Gain Omnidirectional Satellite Antenna Technique," Radiation Systems Inc. TR-68, NASA Contract No. NAS53947, September 1965.
11. W. Korvin and G. G. Chadwick, "A Phased Array Antenna System for Communication Satellites," Electronics, Vol. 39, scheduled for publication in May, 1966.