

X-724-66-539

GPO PRICE \$ \_\_\_\_\_

CFSTI PRICE(S) \$ \_\_\_\_\_

Hard copy (HC) 3.00

Microfiche (MF) 165

NASA

55694

# 653 July 65

# MOBILE AEROBEE LAUNCH FACILITY

BY

J. R. BUSSE

NOVEMBER 1966

N67 18753

(ACCESSION NUMBER)

12  
(PAGES)

NASA TMX 056294  
(NASA CR OR TMX OR AD NUM. BER)

(THRU)

(CODE)

(CATEGORY)

FACILITY FORM 602



GODDARD SPACE FLIGHT CENTER

GREENBELT, MARYLAND

X-724-66-539

MOBILE AEROBEE LAUNCH FACILITY

by

J. R. Busse

November 1966

Goddard Space Flight Center  
Greenbelt, Maryland

# MOBILE AEROBEE LAUNCH FACILITY

Jon R. Busse  
Goddard Space Flight Center  
Greenbelt, Maryland

## Abstract

Pertinent details are provided describing the establishment of the Mobile Aerobee Launch Facility (MALF), a completely portable facility including: 50 foot length launch tower, propellant servicing system, helium pressurization system, launch control console, and rocket handling and loading equipment. MALF was designed and built to permit increased selectivity of launch location for scientists launching space science payloads to observe spatial phenomena only observable from particular geographic locations (solar eclipses, magnetic and other spatial anomalies, southern hemisphere stellar objects, etc.). All aspects of design, construction, assembly, and operation of the portable liquid rocket launching facility, including data on dispersion and wind weighting, methods for analyzing liquid propellants, and packaging and storing techniques, are discussed. Information is provided regarding procedures required for emplacing and operating the facility, and the sequence of events for conducting the first launch operation for the facility in Natal, Brazil (4th quarter 1966). In addition to discussing salient points of conducting launch operations in remote locations using the MALF, the paper outlines future simplifications planned for the facility. Such discussions include the Rail Aero-

bee Launch Facility (RALF), a concept which proposes launching an Aerobee Sounding Rocket from a thirty-foot length rail mounted on a Nike-Ajax military launcher.

## I. Introduction

The Mobile Aerobee Launch Facility (MALF) is a portable facility which includes a launch tower, propellant servicing and helium pressurization systems, launch control console, rocket handling and loading equipment and a combination storage and workshop trailer. The MALF has been established to permit increased selectivity in the launch location of space science payloads flown on the Aerobee 150 rocket (see Figures 1a and 1b) and thus permits scientists to observe spatial phenomena only observable from particular geographic locations. Examples of these spatial phenomena are solar eclipses, magnetic and other anomalies, and southern hemisphere stellar objects. The initial Aerobee 150 launch from the MALF will scan segments of the southern sky inaccessible from the northern hemisphere to identify new x-ray source regions. The launch will be conducted from the Brazilian launch range in Natal (5° 54' S, 35° 15' W) where the MALF is presently located.

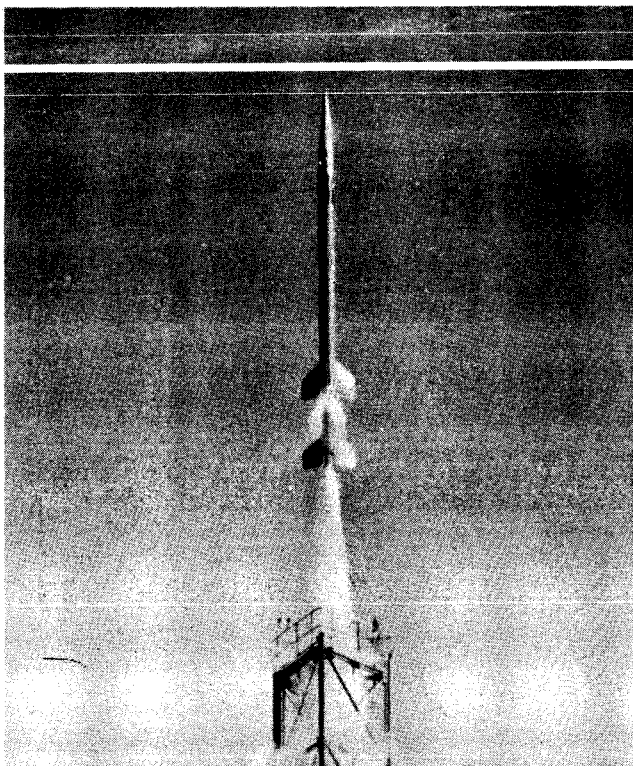

Figure 1a. Aerobee 150  
Exiting Launch Tower

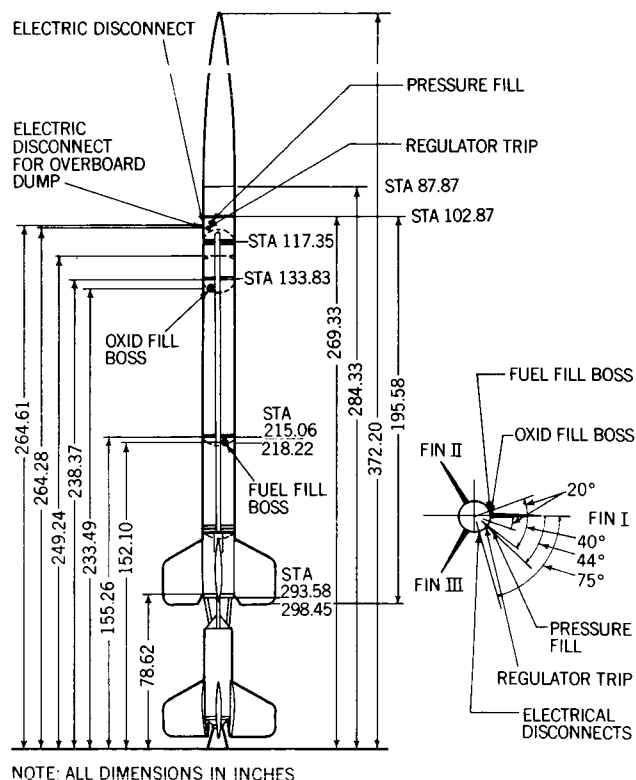

Figure 1b. Aerobee 150 Outline Drawing Showing  
Dimensions and All Umbilical Connections

The facility was developed at a low cost (less than \$50,000) making maximum use of existing hardware and proven components and designs. The low facility development cost coupled with the reliability and versatility of the Aerobee 150 vehicle, which has a success rate of more than 90% in over 500 launches, made the concept very practical to meet space science exploration requirements. The versatility of the Aerobee 150 is reflected in the wide variation in payload weights (100 to 350 pounds); payload volumes (up to 12 cubic feet); and the variety of ancillary equipment, including yo-yo and gas despin systems; solar, inertial, and stellar pointing controls with pointing errors of less than 1 minute of arc; many standard payload tip and door ejection systems; and a recovery package that has had more than 50 consecutive successful flights.

The facility utilizes a launch tower that was originally used for five shipboard launches in 1949. The tower was 90 feet long at that time and was mounted on the USS Norton Sound. Subsequently, the tower was shortened to 70 feet in length (for unknown reasons) and cut into three pieces for purposes of storage and transportation. In 1962 the Naval Ordnance Test Station (NOTS), China Lake, California contracted with the Food Machinery Chemical Corporation to incorporate platforms on the tower for personnel working areas. In addition FMC built an erector on which the 70 foot tower was mounted to position the tower in elevation and azimuth. The tower and erector combination were used by NOTS for six launches from Walker Cay in the Bahamas in 1963 and 1964. Upon completion of the Walker Cay program, the Advanced Research Projects Agency (ARPA) of the Department of Defense (DOD) transferred the launcher and other usable ancillary equipment to NASA, Goddard Space Flight Center (GSFC).

For MALF operations the tower has been shortened from 70 feet to 50 feet in length by removing one of the three tower sections. The tower was shortened this 20 feet to improve the transportation and handling characteristics of the facility. The increase in dispersion, which is the only detrimental effect of shortening the tower, is not of sufficient magnitude to cause concern. Dispersion data for the present 50-foot tower length is presented later in this report. Figure 2 shows a sketch of the present launcher configuration which includes two tower sections and the erector. Figure 2 also shows the rocket being positioned for a loading operation. The rocket and pay-

load are breech loaded into the tower when the tower is in a horizontal position by using two "A" frames and a loading rail which projects from the back of the tower. Figure 3a shows a picture of the launcher in the erected position in Natal, Brazil, and Figure 3b shows the tower during checkout at Goddard Space Flight Center.

For mobility, the tower is separated into two sections and mounted on specially built trailers. The third piece, the erector, has an integral trailer-truck hitch and four sets of detachable wheels which provides its mobility. The three pieces are pictured in Figure 4 prior to emplacement and assembly in Natal.

The non-portable aspect of the MALF is the launch pad to which the tower and the erector are attached. Figure 5 shows the pad that was constructed in Natal to accommodate the launcher. The design required a minimum amount of concrete and labor but still represents the only portion of the MALF that is not transportable. In Brazil, the launch pad was built in a period of three days. An additional eight days curing time for the concrete was required before the initial launcher erection. A small amount of launch dynamics analysis was performed to verify structural integrity of the launcher and pad. As the launcher had already been analyzed and used for six launches in a longer configuration, i.e., the tower was seventy feet long at that time, the main analysis was performed on the launcher-launch pad interactions. A load of sufficient magnitude to fail the rocket was applied at the top of the launcher and large positive margins resulted everywhere in the pad indicating a conservative design.

While the launcher emplacement in Brazil was accomplished with assistance of a crane, the emplacement could have been accomplished with the "A" frames that are also used for rocket handling. However, if the "A" frames are used to emplace the tower, a hard surface must be provided around the launch pad for the "A" frames to roll on.

## II. Ancillary Equipment

The ancillary equipment used with the MALF reflects the designs currently used at White Sands, Fort Churchill, and Wallops Island missile ranges. Improvements and simplification of design have been incorporated where practical. High reliability and safety were emphasized in the design and construction of all equipment, especially

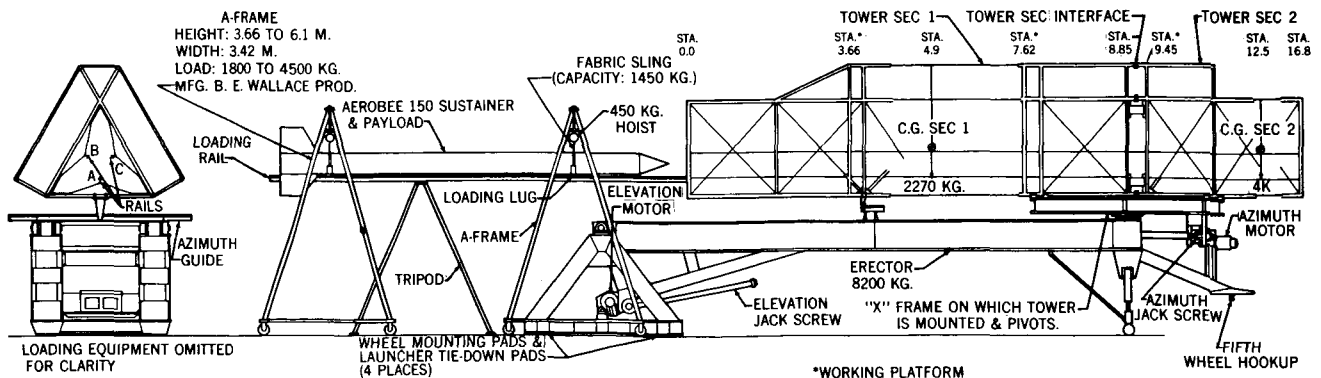

Figure 2. Launching Configuration; Launcher Loading Altitude

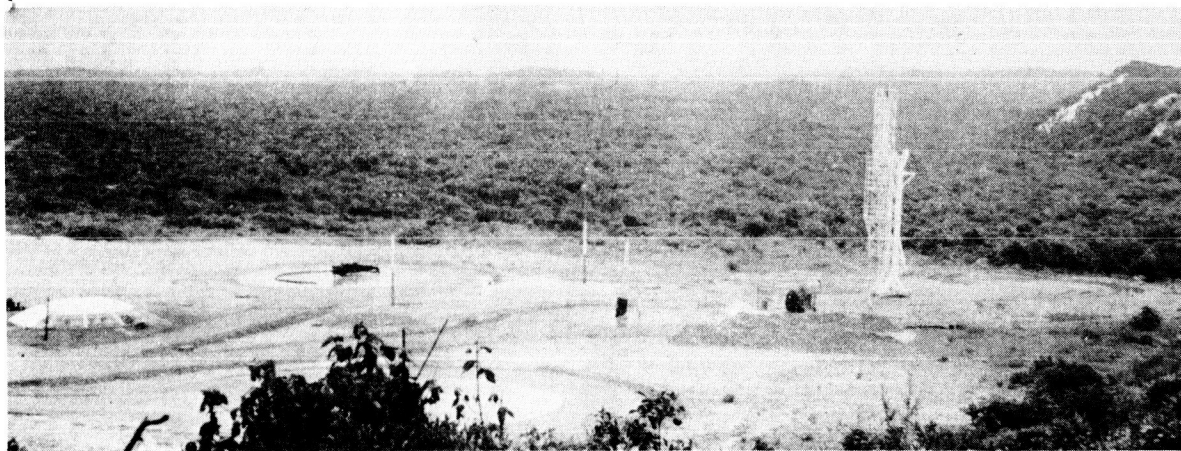

Figure 3a. Launcher in Erected Position in Natal, Brazil

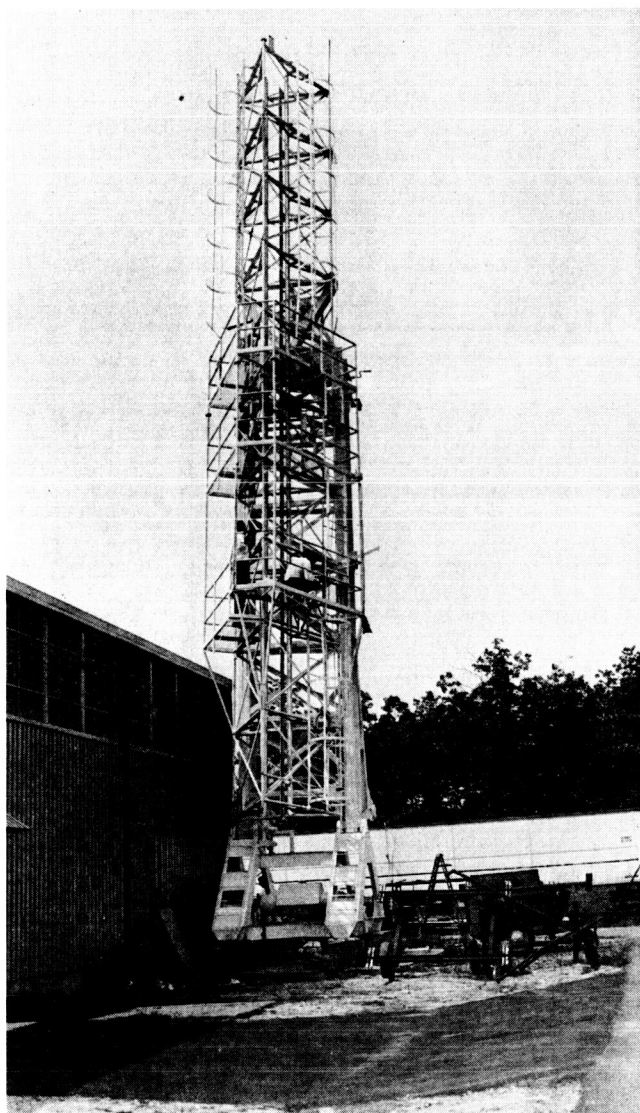

Figure 3b. Launcher in Erected Position During Check-out at Goddard Space Flight Center

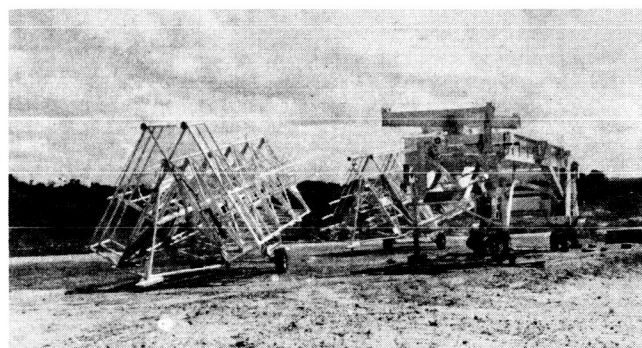

Figure 4. Tower Sections; Mobile Aerobee Launch Facility

remoteness of potential launch areas and the resulting non-availability of replaceable components (except those carried as spares) and the frequent lack of adequate medical facilities.

#### High Pressure Helium System

Figure 6 shows a schematic diagram of the high pressure helium system. The system expands helium at an initial pressure of 6000 PSI through a helium flow control console into the rocket. The 24 cubic feet of 6000 PSI helium carried on each helium cart, is sufficient to pressurize six Aerobee 150 rockets - each rocket requiring 2.5 cubic feet of 3,500 PSI helium. American Instrument Company (AMINCO) super pressure equipment was used throughout the system. For example, the valves are rated at 30,000 PSI working pressure and the tubing is rated at 60,000 PSI working pressure. Such plumbing gives large margins of safety for a small cost in dollars and pounds of weight. The large margins of safety are desirable considering the varying environments to which the equipment is subjected in transportation, storage, and operation, and in addition, frequent replacement and refurbishment of parts is not practical. The helium flow is controlled by a variable orifice which is manually set from a 0 to 0.050 inch diameter equivalent sharp edge orifice to pressurize the rocket helium bottle in time varying from 5 to 30 minutes. Flow is established by either operating a hand valve on the helium control console or by operating the

the propellant and helium servicing systems. Reliability and safety are of particular importance because of the

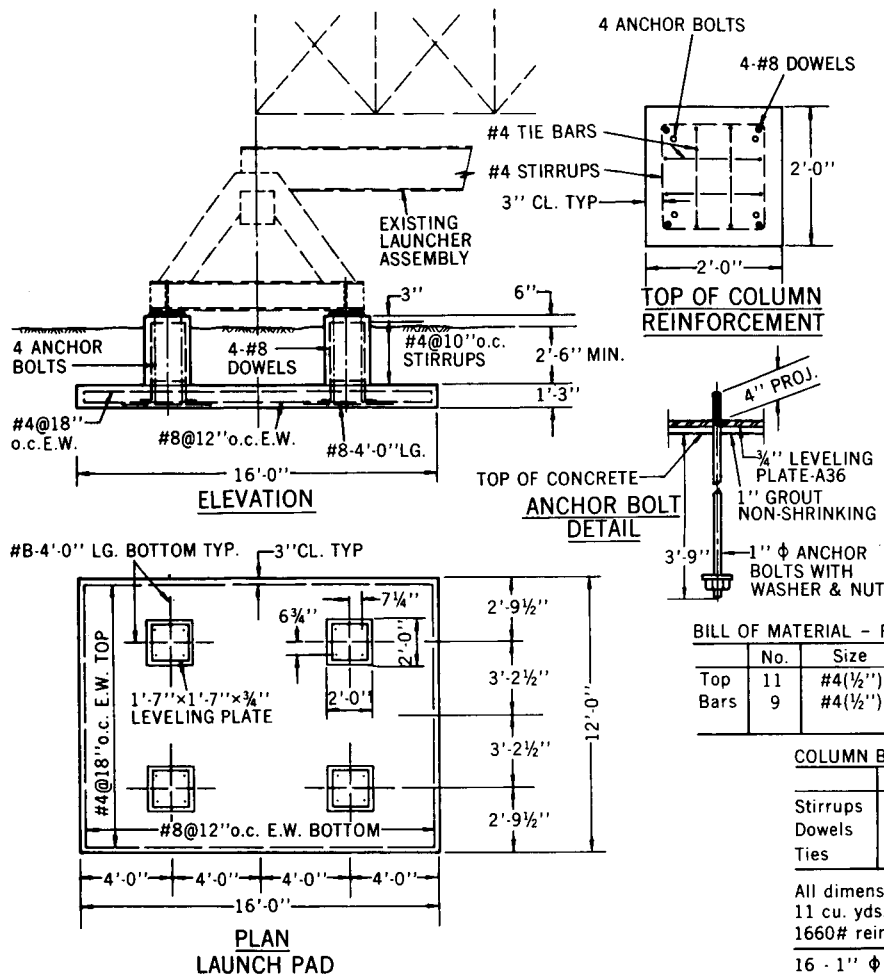

- GENERAL NOTES:
- 1 - All concrete shall be 3000 P.S.I. min. compressive strength at 28 days.
  - 2 - Reinforced steel: ASTM A-15 intermediate grade, deformed bar.

BILL OF MATERIAL - FOOTING - STRAIGHT BARS

	No.	Size	Length		No.	Size	Length
Top Bars	11	#4(1/2")	11'-6"	Bottom Bars	17	#8(1")	11'-6"
	9	#4(1/2")	15'-6"		13	#8(1")	15'-6"
					8	#8(1")	4'-0"

COLUMN BENT BARS

	No.	Size	Length
Stirrups	16	#4(1/2")	6'-6"
Dowels	16	#8(1")	4'-3"
Ties	16	#4(1/2")	2'-9"

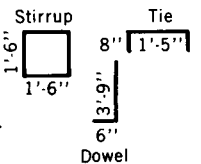

All dimensions are out to out  
 11 cu. yds. of concrete  
 1660# reinforcing bars

16 - 1"  $\phi$  anchor bolts w/washers & nuts  
 4 - 1'-7" x 3/4" leveling plates

Figure 5. Launch Pad for Aerobee Mobile Launch Tower in Natal, Brazil

solenoid fill valve on the helium console from the firing console at a remote location. The venting operation may be accomplished either at the helium control console or remotely through a solenoid valve. The remote operation using the solenoid valves is the more desirable one; however, a completely manually system of pressurizing is available if conditions warrant.

The use of large volume, high pressure helium bottles to fill the rocket eliminates the need for a helium compressor and other ancillary equipment. This greatly simplifies the operation and requires only that the bottles be returned to the United States, or other places which have a high pressure helium pumping capability, infrequently for refilling operations. As an example, the helium contained on one trailer is adequate to pressurize all rockets anticipated for launch in an 18 month period. A small helium booster pump, built by Sprague Engineering, is included with the MALF equipment for emergency use. The pump, driven by compressed air, could boost low pressure helium to the required 3500 PSI rocket pressure. The helium control console and the tubing (both flexible and hard line) between the helium supply and the tower can be assembled in a very short period of time and likewise disassembled rapidly. The rigid tubing is cut in 10-foot lengths for ease of storage and transportation.

Propellant Servicing System

Figure 7 shows a sketch of the propellant servicing system. Two systems, one for fuel and one for oxidizer, are required. For simplicity of design and maintenance, especially maintenance of spare parts, both systems are identical - the components of the fuel system are compatible with acid and vice versa but obviously not at the same time.

The drums that the vendor (General Chemical Division of Allied Chemical Corporation) delivers the acid in are used for pumping acid into the rocket. The normal drum cap is replaced with a propellant "thief" just prior to propellant servicing. The propellant is pumped from the drum with an Eco pump and into the rocket via a flex line "Y" nozzle combination (see Figure 7 again). The proximity of the propellants and transfer equipment to the rocket during servicing simplifies the operation and minimizes the number of people required to conduct propellant servicing. Present plans are to use three people in the propellant servicing operation - one man on the tower to handle the "Y" nozzles and observe the propellant flow through sight glasses, one man to operate the Eco pump and transfer valves on the propellant carts, and one man to stand by in the event of any problems. All men will be equipped with propellant servicing outfits similar to those used at

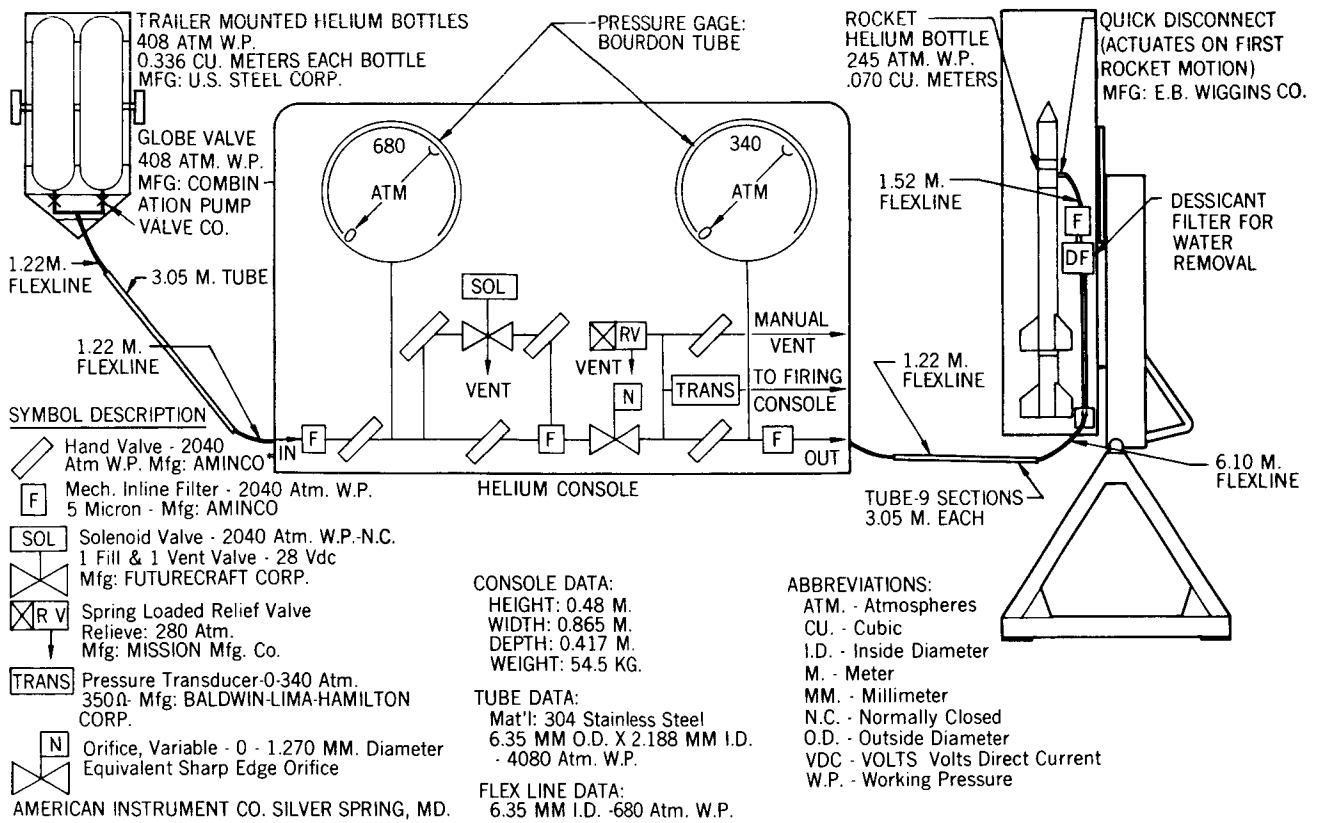

Figure 6. Schematic Diagram; High Pressure Helium System (AMLF)

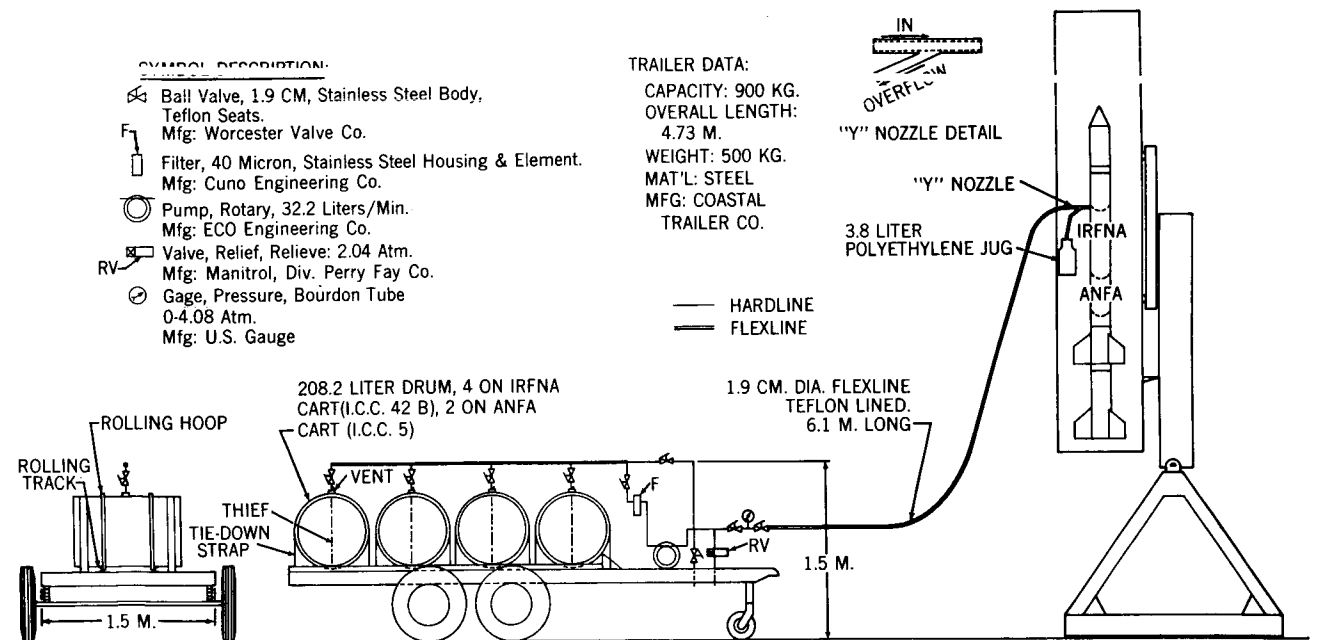

Figure 7. Propellant Servicing System (AMLF)



domestic launch sites. At Natal, a 500 gallon water supply and 60 gallon per minute pump, plus accessories, are available on the launch pad.

### III. Preflight Rocket Preparation Propellant Analysis

Weekly venting of the acid drums is required when the propellants are to be stored for extended periods of time. The fuel which is a mixture of aniline and furfuryl alcohol 65%, 35% respectively by weight are premixed in the United States at either White Sands or Wallops Island, and shipped in drums similar to those used for the acid. Consequently, like the acid, no transfer operations are required in the field except from the storage drums directly to the rocket.

Vendor certifications and analyses conducted just prior to shipment from the United States are relied upon primarily for assuring proper composition of the liquid propellants. Field tests are limited to visual examination of samples, specific gravity measurements, and 10% accuracy water and NO<sub>2</sub> determinations which can be performed on the acid only. Years of experience with the fuel indicates that no problems should be encountered if the fuel is properly sealed. If the acid is properly sealed and vented periodically, the only possible problem that can result is acid deterioration from extended time storage at a high temperature (in excess of 100° F). Such dissociation should be apparent from the NO<sub>2</sub> and water determination tests run at the launch site. Consequently, there is no danger of launching a rocket without specification propellants, only the remote possibility of being inconvenienced while waiting for delivery of a new propellant supply. Checkout operations run at GSFC indicate that the total propellant servicing time for a rocket should not exceed one hour.

#### Rocket and Booster Preparation

The sustainer and booster handling procedures and equipment for buildup of the Aerobee 150 rockets used with the MALF are the same as those utilized at Wallops Island, White Sands and Fort Churchill missile ranges. The same checkout procedures, including the gas leak checks, thrust chamber misalignment checks and fin alignment checks, are used on mobile facility launches as elsewhere. To facilitate the checkout, however, parts of the rocket that are normally disassembled in the field before launch are disassembled and re-assembled in the United States prior to shipment to the mobile launch site. Likewise the fins are set prior to shipment and the settings are merely verified in the field. Rocket wiring and plumbing of pressure transducers and other ancillary equipment such as gas despin systems is accomplished prior to shipment. Performance of checks and installations in the United States simplifies the operation in a remote site. However, in the event of difficulty, any rocket check could be accomplished or any rocket component replaced at the mobile launch site - provided the parts are available.

#### Rocket-Tower Installation

The tower loading operation is accomplished by transferring the rocket and payload from the handling dolly to

hoist operated slings mounted on two "A" frames (see Figure 2). After transfer to the slings, the sustainer and payload are raised horizontally approximately 15 feet into the air until the rocket is slightly above the loading rail, which projects back from the launch tower. The rocket is then translated over the loading rail and lowered down on to the rail. Two sets of special lugs on the sustainer engage the channel cross section of the loading rail. A cable which is passed down the center of the bore of the launch tower is attached to the nose of the rocket and the rocket is pulled slowly into the tower by retracting the cable with the boreage hoist. The "A" frames are moved forward toward the tower with the rocket as long as possible to provide additional safety in the loading operation. After the sustainer has been pulled into the bore approximately eight feet, the operation is repeated with the Aerobee booster. After the sustainer and booster are mated in the bore of the tower the special loading shoes are removed and three plates are attached to the tower rails aft of the booster to provide support for the rocket assembly during erection of the launcher.

The rocket and payload procedures employed after the rocket and payload are installed in the tower are substantially the same as those followed at the other Aerobee launch facilities. No special tests or procedures are required. The working space on the tower itself is considerably less than that on the larger towers such as White Sands; consequently, the scientists are encouraged to minimize their payload work after installation of the payload in the tower.

#### Launch Control System

The launch control systems for this facility is in two consoles. The larger launcher control console contains the transformer rectifier and other electrical hardware and circuitry to position the launcher and readout the position. The launcher control console uses the equipment from the Walker Cay facility repackaged in a weather-tight console. The firing console is contained in a "suitcase" weighing approximately 15 pounds, and is shown in Figure 8. The "suitcase" firing console and associated circuitry were designed and built by the Washington Technological Associates of Rockville, Maryland. The functions of the launch control system are to position the tower in azimuth and elevation, to readout the azimuth and elevation, to pressurize the rocket, to monitor the firing circuits, and to launch the rocket.

#### Dispersion and Wind Weighting

Of particular importance to the missile ranges at which the mobile facility will be used in the dispersion, wind weighting and performance information. Figures 9 and 10 summarize the performance of the Aerobee 150 rocket when launched from sea level. Based on this performance, Space General Corporation, El Monte, California performed a dispersion study.\* The increase in dispersion due to the 50 foot length tower over that experienced at

\*Aerobee 150 Dispersion and Wind Weighting Data for 50 Foot Mobile Launch Tower, Report No. 870 FR-7, Space General Corp., El Monte, California.



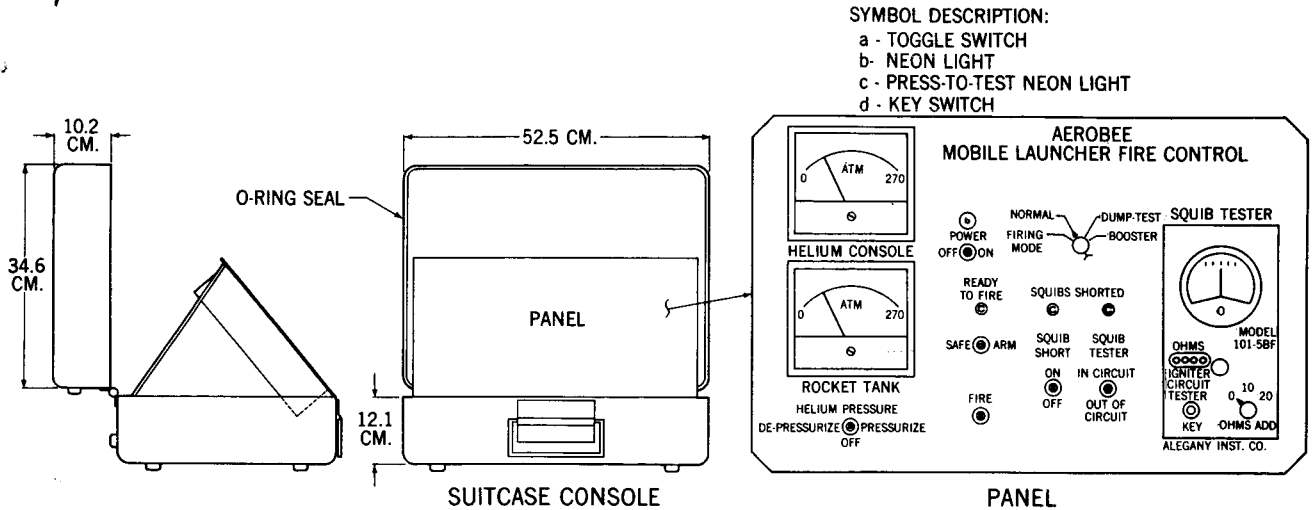

Figure 8. Aerobee Mobile Launcher Fire Control Console

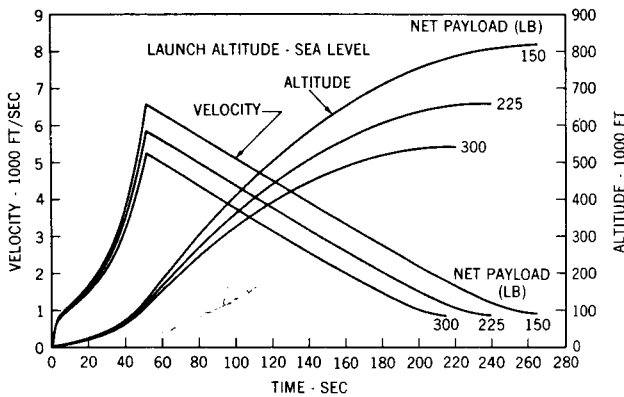

Figure 9. Aerobee 150 Altitude and Velocity vs Time (Sea Level Launch)

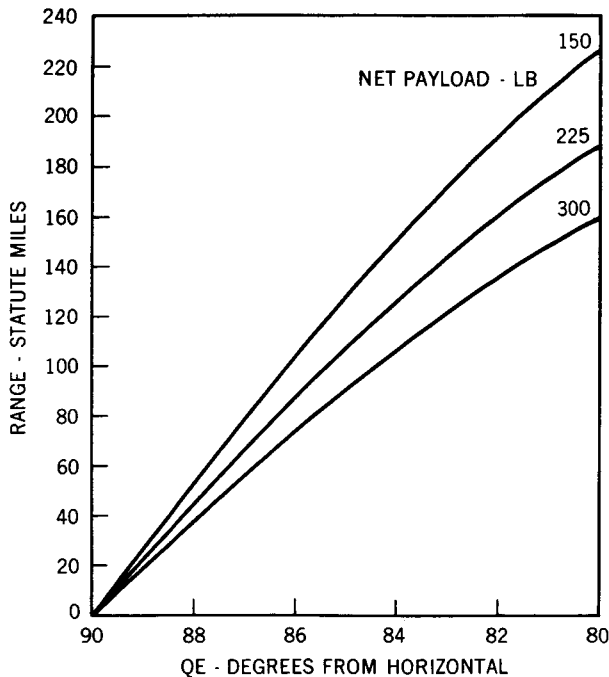

Figure 10. Aerobee 150 Range vs Launch Elevation (Sea Level Launch - Mobile Tower)

the other missile ranges was of special interest. The resulting two sigma dispersion for the Aerobee 150 was computed to be a circle of 30.4 statute miles radius. The two sigma dispersion circle radius for the Aerobee booster was computed to be 835 feet. Since the effective launcher elevation is expected to be no more than 87°, no problems should exist because an impact range of 63 s.m. is expected with a nominal payload at an effective elevation of 87°. The wind weighting factor, ballistic factor, tower tilt displacement, and a tower setting nomograph are shown in Figures 11, 12, 13, and 14 for information purposes. Comparable data were generated for the booster but are not included here for purposes of brevity. The outstanding feature of the dispersion study is that the Aerobee dispersion does not go to prohibitive values even though the tower length has been reduced to one third the length of the existing White Sands towers. This factor takes on additional significance when considering Aerobee launches from an even shorter rail launcher.

#### IV. Future Possibilities

While the Mobile Aerobee Launch Facility is a significant improvement to sounding rocket operations, in that it adds versatility to the very useful Aerobee 150 rocket system, additional streamlining of operations is in process

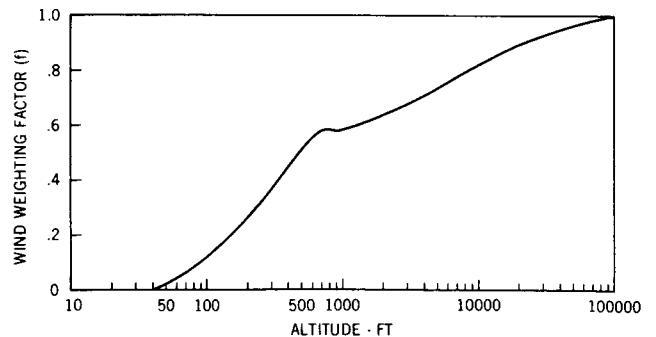

Figure 11. Aerobee 150 Wind Weighting Factor vs Altitude; Mobile Tower; Rail Length 50 Feet (Effective Length 41 Feet); Sea Level Launch

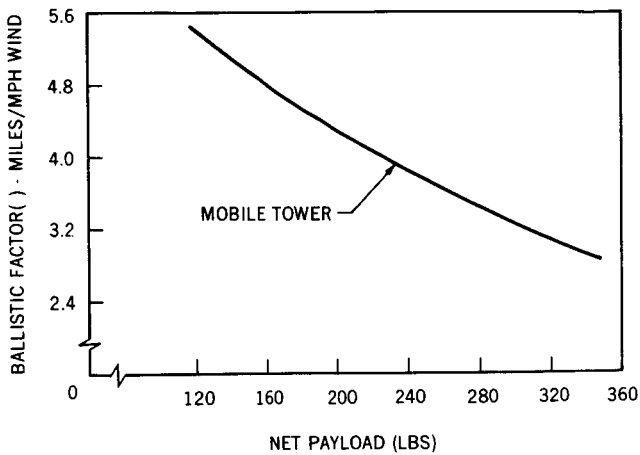

Figure 12. Aerobee 150 Ballistic Factor vs Net Payload; Mobile Tower; Sea Level Launch

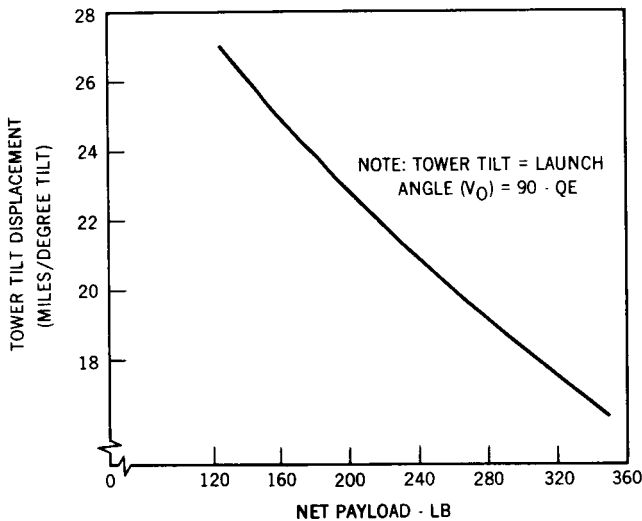

Figure 13. Aerobee 150 Tower Tilt Displacement vs Net Payload; Mobile Tower; Sea Level Launch

and should be in practice within the next year. In the next generation the Aerobee launch facility is appropriately named the Rail Aerobee Launch Facility (RALF). The RALF concept proposes launching an Aerobee from a 30 foot rail mounted on a Nike Ajax military launcher. The advantages of the RALF concept are:

- (1) It utilizes a smaller, more portable launcher.
- (2) There are many Nike Ajax launchers already emplaced around the world for example India, Sweden, Norway, Alaska, Argentina, Brazil and elsewhere, which further simplifies the logistics.
- (3) The bulky launcher control console will no longer be required.

All other ground support equipment will remain essentially unchanged and only a portable gantry type tower will have to be built to replace the existing work areas on Aerobee towers. The so-called gantry would be placed around the Nike Ajax launcher after the Aerobee rocket and payload have been mounted on the launcher and erected. The gantry would be used during payload checkout, pro-

pellant servicing and final rocket launch preparations. Just prior to launch (approximately T-2 hours) the gantry would be removed. The gantry could be fabricated from lightweight material such as aluminum and would be of a "knockdown" type of construction to maintain the requirement of simplicity, light weight, and small volume, for shipment and handling.

There are three major problems to be solved before conducting an operational launch of an Aerobee from a rail launcher. The first is to design launch lugs and a rail on which to mount the Aerobee. The second is to assure that the dispersion does not reach values that would prohibit its use at foreign launch sites. The dispersion work already performed on the MALF indicates that the second problem should not be of great magnitude.

The third problem is to determine the dynamic characteristics of an Aerobee 150 on an exiting from a 30 foot rail. This is certainly the biggest problem and will require at least a dummy launch off of a Nike-Ajax launcher with a modified rail to confirm calculations. A dummy launch is a launch with an inert Aerobee sustainer and a live booster. The inert sustainer would have the same structural and mass distribution properties as the Aerobee 150 sustainer.

As a future program, consideration is being given to rail launching an Aerobee 350. The Aerobee 350 utilizes a cluster of 4 Aerobee 150 thrust chambers and 4 times as much propellant as the Aerobee 150, a Nike solid propellant booster, is 22 inches in diameter, and can carry payloads in excess of 500 pounds. It is reasonable to expect requirements for launching rockets with the capabilities of the Aerobee 350 from various geographic locations. A Nike Hercules or other heavy duty rail or boom launcher would logically be used for the Aerobee 350 launcher. While all the existing information on the Aerobee 350 mobile launch system is preliminary, the concept is mentioned here in the hope of creating interest and constructive suggestions for establishing such a facility.

## V. Conclusion

To summarize, the MALF provides scientists with an existing capability of launching Aerobee 150 rocket systems from anywhere in the world. While the launcher is currently located in Natal, Brazil there are certainly no restrictions on moving it to any other desired location. The Mobile Aerobee Launch Facility retains all of the operational features and characteristics of the existing launch facilities. Consequently, scientists familiar with existing Aerobee operations will have no problems in adapting to an Aerobee launch in a remote location. The Rail Aerobee Launch Facility (RALF) promises even more flexibility in terms of selecting launch locations and will give the scientists a large number of locations to choose from, any of which could be established as Aerobee launch sites. With RALF, six or eight Aerobee launch sites could be established with no more investment than the cost of the ground support equipment, which is less than \$25,000 per launch site. The future is indeed bright for scientists desiring launches of sophisticated payloads with equally sophisticated ancillary hardware from geographic locations previously considered inaccessible.

I. PROCEDURE FOR MOBILE TOWER SETTING

- (1) Record desired impact point: Range = \_\_\_\_\_ Statute Miles  
Azimuth = \_\_\_\_\_ Degrees
- (2) Record Net payload weight: NPL = \_\_\_\_\_ lb
- (3) Determine ballistic wind from north \_\_\_\_\_ Ft/Sec (Pos. from north)  
(Neg. from south)
- (4) Determine ballistic wind from east \_\_\_\_\_ Ft/Sec (Pos. from east)  
(Neg. from west)
- (5) Mark desired impact point on upper right hand figure of tower setting graph.
- (6) Project lines from marked impact point to left and down (parallel to quadruled grid) to intersect with appropriate payload line from Step 2.
- (7) Follow curving grid lines to 150 lb net payload lines (starting from intersections of Step 6).
- (8) Project lines to left and down (from intersections with 150 lb payload lines) to intersect appropriate ballistic wind lines (from Steps 3 and 4).
- (9) Project lines down and to left (from intersections of Step 8) to intersect on polar grid in lower left of tower setting graph.
- (10) Read required tower azimuth and elevation at intersection of Step 9.

Tower Azimuth = \_\_\_\_\_ Degrees

Tower Elevation = \_\_\_\_\_ Degrees

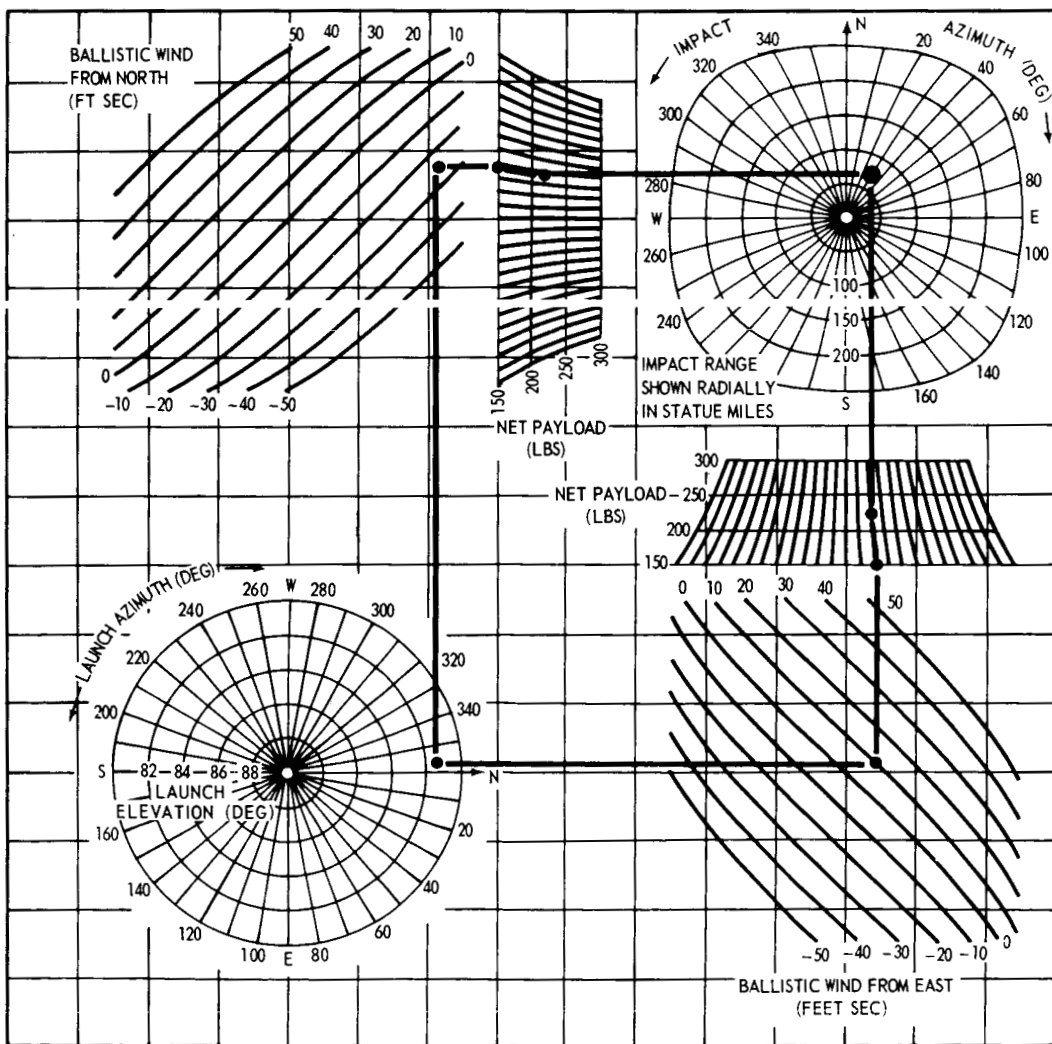

Figure 14. Aerobee Tower Setting Graph; 50 Foot Mobile Launcher