

NASA TECHNICAL NOTE

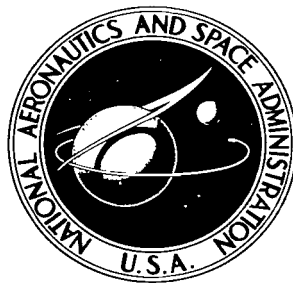

NASA TN D-4227

c.1

NASA TN D-4227

LOAN COPY
AFWL
KIRTLAND



**EXPERIMENTAL STEADY-STATE PERFORMANCE
OF A MULTITUBE, CENTRALLY FINNED,
POTASSIUM CONDENSING RADIATOR**

by Orlando A. Gutierrez, Loren W. Acker, and Nick J. Sekas

Lewis Research Center

Cleveland, Ohio

TECH LIBRARY KAFB, NM



0130909

EXPERIMENTAL STEADY-STATE PERFORMANCE OF A MULTITUBE,
CENTRALLY FINNED, POTASSIUM CONDENSING RADIATOR

By Orlando A. Gutierrez, Loren W. Acker, and Nick J. Sekas

Lewis Research Center
Cleveland, Ohio

NATIONAL AERONAUTICS AND SPACE ADMINISTRATION

For sale by the Clearinghouse for Federal Scientific and Technical Information
Springfield, Virginia 22151 - CFSTI price \$3.00



CONTENTS

	Page
SUMMARY	1
INTRODUCTION	1
FACILITY	3
Heating Loop	3
Two-Phase Loop	3
Heat Sink	4
TEST CONDENSING RADIATOR	4
Description	4
Design	5
Mounting	7
INSTRUMENTATION	7
Loop Instrumentation	7
Flow rate	7
Temperature	7
Pressure	8
Electric power	9
Condensing Radiator Instrumentation	9
Header temperatures	10
Longitudinal temperature profiles	10
Cross-sectional temperature profiles	10
Recording Equipment	10
Temperatures	10
Pressures	10
Flow rates	10
EXPERIMENTAL PROCEDURE	11
Filling and Starting	11
All-Liquid Runs	11
Transition from Liquid to Two-Phase Operation	12
Condensing Runs	12
DATA HANDLING	12
Data Acquisition	12

Data Reduction	13
Analytical Procedure	14
RESULTS AND DISCUSSION	14
Temperature Profiles	15
Longitudinal temperature profiles	15
Cross-sectional temperature profiles	16
Pressure Drop	17
Tube entrance pressure drop	17
Overall pressure drop	17
Correlation of tube two-phase frictional pressure drop with results from other fluids	18
Condensing Length	18
Stability	19
SUMMARY OF RESULTS	20
APPENDIXES	
A - SYMBOLS	22
B - ALL-LIQUID DATA REDUCTION	26
C - CONDENSING DATA REDUCTION	30
D - ANALYTICAL METHODS USED TO PREDICT PERFORMANCE OF CONDENSING RADIATOR	36
E - MAXIMUM SYSTEMIC ERROR DUE TO RADIATOR TUBE SURFACE THERMOCOUPLE APPLICATION	43
REFERENCES	45

EXPERIMENTAL STEADY-STATE PERFORMANCE OF A MULTITUBE,
CENTRALLY FINNED, POTASSIUM CONDENSING RADIATOR
by Orlando A. Gutierrez, Loren W. Acker, and Nick J. Sekas
Lewis Research Center

SUMMARY

A horizontal, multitube, centrally finned radiator panel was operated as a potassium condenser in a vacuum environment as part of a research program applied to advanced Rankine cycle system components. The AISI 316 stainless-steel radiator panel consisted of nine tubes 14 feet long manifolded into common inlet and outlet headers. The finned tubes had a 0.500-inch (1.27 cm) inside diameter with 0.42-inch-thick (1.07 cm) walls; the fins were 0.84 inch (2.13 cm) wide and 0.082 inch (0.208 cm) thick.

The potassium condensing radiator was operated at nominal vapor temperatures of 1700^o R (944^o K), 1810^o R (1006^o K), and 1890^o R (1050^o K) at vapor flow rates ranging from 122 to 468 pounds per hour (55 to 212 kg/hr) and with inlet qualities from 0.50 to 0.95. No operational difficulties were encountered.

Longitudinal temperature profiles along each of the tubes were measured as a means of determining condensing lengths. Transverse temperature profiles along the surface of tubes and fins were also obtained at three different locations.

Condensing lengths and pressure drops were compared with values predicted by the use of a two-dimensional heat-transfer analysis of the tube-fin cross section, and by a Martinelli-Lockhart two-phase correlation, respectively. Predicted condensing lengths were 11 to 19 percent shorter than measured values.

The measured entrance pressure loss to the tubes yielded a loss coefficient between 1.1 and 1.2. Two-phase frictional pressure drop in the tubes for inlet qualities above 0.65 correlated satisfactorily with data for water and Freon-113, using single-phase vapor inlet flow conditions.

INTRODUCTION

Future exploration of space may require rather large amounts of electrical power

for propulsion systems, life support systems, and operation of scientific experiments. One method of generating electrical power is to drive an electric generator with a turbine in a Rankine cycle system. In this cycle, vapor is generated in a boiler, expanded through a turbine and then condensed. The liquid condensate is pumped back to the boiler and reevaporized. The heat source for the system could be a nuclear reactor or a large solar collector. The waste heat of the cycle, the heat of condensation, must ultimately be rejected to space by thermal radiation since no fluid heat sinks are available.

There exist two alternate heat rejecting schemes: one in which the turbine outlet vapor is condensed in a small heat exchanger, transferring the heat of condensation to an auxiliary cooling fluid which, in turn, releases the heat to space in a radiator, and the other wherein the working vapor is condensed in a radiator directly. In either case, the radiator is a large, heavy component of the system. Its heat flux is proportional to the fourth power of its surface temperature. Therefore, to minimize size, the temperature of the radiator fluid should be maintained at a high level.

Alkali metals, such as potassium, sodium, etc., are being considered as cycle fluids. One of the main advantages offered by these fluids is high saturation temperature at low vapor pressure. As previously indicated, high vapor temperatures decrease the required size of the system components. Other properties of the alkali metals that make their use attractive are good wetting characteristics, high liquid thermal conductivity, and large latent heats.

A considerable amount of analytical work, as indicated in the bibliographies of references 1 to 3, has been done on the subject of radiative condenser design. Experimental data on condensing radiators, on the other hand, is scarce in the literature. To help fill this void, a program was established at the Lewis Research Center to obtain data on the performance of a near-prototype liquid-metal condensing radiator. In this program, the test performance was to be compared with analytical predictions and any unforeseen operating problems were to be evaluated.

Potassium was the alkali metal selected as test fluid for this investigation. A condensing radiator of the centrally finned tube type was designed by using the procedure developed in reference 1. A segment of the resultant radiator, capable of dissipating up to 150 kilowatts thermal, was fabricated, instrumented, and tested in a vacuum environment. Data were obtained for potassium vapor flow rates varying from 122 to 468 pounds per hour (55 to 212 kg/hr) with vapor temperatures ranging from 1690^o to 1890^o R (939^o to 1050^o K).

Presented in this report are a description of the condensing radiator, its instrumentation, the data obtained during the program, comparison with analytical values from reference 2, and observations on the radiator performance. All values, dimensional equations, tabular material, and figures are presented in both U. S. Customary and SI units. The dimensional equations in the SI Units are enclosed in brackets.

FACILITY

The alkali metal facility used for this investigation is shown schematically in figure 1. This facility consists of three heat-transfer systems: an all-liquid heating loop, a two-phase flow loop, and a heat sink consisting of an oil-cooled vacuum chamber.

Heating Loop

Liquid NaK 78 (a eutectic of sodium and potassium) in the heating loop can be pumped at rates up to 35 000 pounds per hour (15 876 kg/hr) through an electric heater that has a capacity of 200 kilowatts. The flowing liquid metal serves as the resistance load. The heated liquid then flows through the shell side of the shell-and-tube boiler and returns to the pump for recirculation. The pump is an electromagnetic alternating-current conduction pump with circuitry arranged to allow reversal of the flow direction and thus permits operation of the boiler in countercurrent or cocurrent flow.

Flow control is accomplished by manual changes of pump voltage. Heater power input is automatically controlled to maintain any preselected value of heater outlet temperature.

Two-Phase Loop

The two-phase loop, which uses potassium as the test fluid, is mounted essentially in one horizontal plane to minimize the effect of gravity in the performance of the boiler and condensing radiator. Liquid potassium is supplied to the tube side of the boiler where it is vaporized. The boiler consists of 43 parallel 0.375-inch (0.952 cm) outside-diameter by 0.035-inch (0.089 cm) wall tubes 14 feet (427 cm) long, mounted inside a 4-inch (10.2 cm) inside-diameter shell. Each tube has a 0.040-inch-diameter (0.102 cm) orifice at the liquid potassium inlet to improve boiler stability. The potassium vapor leaves the boiler through a 2-inch schedule-40 pipe (6.03-cm o. d. by 5.25-cm i. d.). For 20 feet (610 cm), this vapor pipe is wrapped with electric radiant heaters that have a total capacity of 5 kilowatts. This unit serves as a vapor superheater. A continuation of the vapor pipe then enters the vacuum chamber where the potassium vapor is condensed in the test condensing radiator. This component is described in detail in the next section of this report. The condensed potassium returns to the electromagnetic pump for recirculation through the loop. This pump is capable of handling up to 700 pounds per hour (318 kg/hr) of potassium during two-phase operation of the radiator. Pressure level in the two-phase loop is manually controlled by varying the pressure of the argon cover gas in an inventory tank connected to the pump inlet line. Flow control is achieved manually by adjusting the throttle valve and/or the pump voltage.

All the piping in both the heating and two-phase loops, external to the vacuum chamber, is covered with 6 inches (15.24 cm) of high-temperature insulation (layers of silicon and aluminum oxides and asbestos fibers). Piping inside the vacuum chamber is wrapped with four layers of dimpled stainless-steel foil, which act as radiation shields.

Heat Sink

The vacuum chamber is an 8-foot (244 cm) inside-diameter by 18-foot-long (549 cm) cylindrical tank of double wall construction. Cooling oil flows between the two walls to maintain low inside wall temperatures and to remove the heat radiated from the condensing radiator. The vacuum chamber has a vacuum pumping system capable of holding the chamber pressure at 10^{-3} torr (0.133 N/m^2). At this pressure, the heat transferred by convection is less than 0.1 percent of the total minimum heat-transfer rate expected during two-phase operation. The inner wall of the chamber is manufactured from type 304 stainless steel, with a number 4 grit blast finish. This surface is painted with an organic base black paint that produces a total hemispherical emissivity higher than 0.90. Figure 2 is an overall view of the facility showing the vacuum chamber. The end of the chamber has two view parts that were used to observe the radiator during operation. The cooling oil enters the chamber oil passages at the bottom and flows upward around the walls. The two oil outlet pipes at the top return the coolant to the reservoir. The oil is circulated by a pump through a cooler or heater to control its temperature before it is returned to the vacuum chamber.

A more thorough description of the entire facility used for these condensing radiator tests is presented in reference 4.

TEST CONDENSING RADIATOR

Description

The potassium-condensing test radiator is shown in figure 3. It consists of nine centrally finned tubes approximately 14 feet (427 cm) long welded to common inlet (vapor) and outlet (condensate) headers. All the tubes and fins are in the same plane. The material is AISI 316 stainless steel throughout. The tubes (section A-A) have a 0.500-inch (1.27 cm) inside diameter and a 0.42-inch-thick (1.07 cm) wall. The centrally located fins are 0.84 inch (2.13 cm) wide and 0.082 inch (0.208 cm) thick. The tubes were welded to the bottom of the inlet header (section B-B) on a 3.25-inch (8.26 cm) center-to-center spacing, with the tube entrances being rounded and smoothed. A gap of 0.1875 inch (0.476 cm) was left between the edges of adjacent fins, and 0.0625-inch-wide

(0.159 cm) expansion slots were cut through the fins every 4 inches (10.16 cm). An expansion loop fabricated from 0.375-inch (0.952 cm) outside diameter by 0.065 inch (0.165 cm) wall tubing was provided at the condensate end of each tube, ahead of the outlet header, to allow for thermal expansion of the tubes (as much as 2.5 in. (6.35 cm)).

The inlet header is of constant cross section, made from a $3\frac{1}{2}$ -inch schedule-40 pipe (10.16-cm o. d. by 9.01-cm i. d.) (section B-B). One quarter of the pipe cross section was cut away and replaced by a machined section matching the inside diameter of the pipe and incorporating the entrances to the nine radiator tubes. Figure 4(a) shows the machined section of the inlet header with the tubes attached and the entrances finished, but prior to welding to the rest of the header. The upstream end of the header terminates on a $3\frac{1}{2}$ - by 2-inch (10.16 cm by 6.03 cm) concentric pipe reducer at the connection to the vapor inlet pipe. The other end of the header is closed by a welded pipe cap.

The outlet header is a 1.25-inch-square (3.18 cm) bar with a 0.825-inch-diameter (2.10 cm) passage. The nine expansion loops were welded to the bar, as shown in section C-C of figure 3(b). The outlet header and the expansion loops are shown in figure 4(b). The outlet header and expansion loops were enclosed in a low-emissivity shielding box to reduce the heat losses.

A top view of the radiator shows the inlet header and the nine parallel finned tubes (fig. 4(c)). At the top and bottom centers of each tube are 1/16-inch (0.16 cm) sheathed heater wires peened inside a groove along the tube wall. These heaters were used for preheating the radiator tubes above the freezing point of potassium before filling the system. The gaps between adjacent fins as well as the slots cut in the fins are also shown in the figure.

After fabrication was completed, the outside surface of the whole radiator was sand-blasted and oxidized to provide a stable high-emissivity surface. The oxidation of the surface was accomplished by inserting the radiator in an open air furnace at 1660° R (922° K) for a period of 24 hours. A resultant total hemispherical emissivity of 0.72 to 0.75 at 1840° R (1022° K) was obtained on test coupons that had been attached to the radiator panel throughout the surface preparation procedure. The hemispherical emissivity was derived from the normal spectral emittances measured at operating temperatures, before and after operation, using the method described in reference 5. No change in measurements was noted.

Design

There are different types of radiator surfaces suitable for space applications, such as the ones mentioned in references 6 to 8. The selection of a centrally finned tube with constant cross-section fins from among the different choices available for study was purely arbitrary.

The detailed configuration of the test radiator described in the previous section was arrived at by the space radiator design procedure of reference 1. This procedure yields the centrally finned-tube dimensions required for any specified space mission, given a preselected radiator material, tube inside diameter, vapor inlet temperature, and tube pressure drop. The mission selected as the basis for the design was a 300-kilowatt-electric Rankine cycle power system with a 90-percent probability of successfully completing a 500-day mission in space. This design took into account the meteoroid hazard based on the information available in 1961.

The choice of AISI-type 316 stainless steel as the material of construction was based on the compatibility of this alloy with potassium and its satisfactory physical properties at temperatures up to 2000°R (1111°K). Tubes with an internal diameter of 0.500 inch (1.27 cm) were specified as being sufficiently small to permit condensing in a horizontal plane, while being large enough to reduce the possibilities of plugging or freezing of the liquid metal.

For operating temperatures of 1750°R and 1900°R (972°K and 1056°K), the computer program specified a tube wall thickness of 0.42 inch (1.07 cm), with fins 0.84 inch (2.13 cm) wide and 0.082 inch (0.208 cm) thick, as shown in section A-A of figure 3(b). Also specified were the number of tubes and tube length requirements for a range of tube inlet vapor velocities.

The capacity of the test facility (150 kW thermal) was one-tenth of the waste heat rate of the 300-kilowatt-electric system (1500 kW thermal) used in the design procedure. Therefore, the test radiator could be only one-tenth of the total radiator size specified by the computer program. In order to maintain the performance per tube, the reduction in size was accomplished by maintaining the full-size tube length obtained for all computed cases and reducing the number of tubes and the vapor flow rate to the desired 10 percent of full values. The scaled-down outputs of the computer program are shown in figure 5 with length and number of tubes shown as a function of tube inlet vapor velocity.

The data of figure 5 indicated that a larger range of vapor velocities could be covered as the number of tubes decreased. Therefore, the selection of number of tubes and length combination was made on the basis of the longest length that the chamber could accommodate, which was estimated at 14 feet (427 cm). This tube length was used to obtain a maximum vapor velocity at the inlet of 815 feet per second (248 m/sec) at 1750°R (972°K) from the plot at the right. This velocity required 8.5 as the number of tubes (the plot at the left). The final dimensions of the test condensing radiator panel was thus set at nine parallel 14-foot-long (427 cm) tubes of the chosen cross section.

The inlet header was designed for constant area. Its flow area was determined from the closest standard pipe size that would produce a velocity below 150 feet per second (46 m/sec) for a potassium vapor flow of 590 pounds per hour (267 kg/hr) at 1750°R (972°K). The result was a $3\frac{1}{2}$ -inch schedule-40 (10.16-cm o. d. by 9.01-cm i. d.) pipe.

The connections to the finned tubes were made at the bottom of the header (rather than at the centerline) to prevent pocketing of liquid-metal condensate below the tube entrances (see fig. 3(b)).

Mounting

The potassium condensing radiator was mounted on a horizontal plane in the centerline of the vacuum chamber, as shown in figures 4(c) and 6. No pitch allowance was made, even for drainage purposes. A supporting frame carried the weight of the radiator to the walls of the chamber. Allowances were made for differential thermal expansion. The expansion motion of the tubes with relation to the supports is indicated by the scratches on the tube surfaces shown in figure 7.

The design of the support frame was directed toward minimizing interference with radiation as well as offering a minimum of conduction heat leakage paths. The combined projected area of the supports directly opposite the radiating surface of the test panel was approximately 2 percent of the total radiating surface.

INSTRUMENTATION

Location of instrumentation on the three loops of the facility appears in figure 8. Details of the condensing radiator instrumentation are given in figures 9 and 10. The complete instrument nomenclature is given in appendix A.

Loop Instrumentation

Figure 8 shows schematically the location of instrumented points around the NaK 78 heating loop, the two-phase potassium loop, the vacuum chamber walls, and the oil coolant loop.

Flow rate. - Flow rates in both liquid-metal loops were measured with electromagnetic flowmeters. The magnetic field strength of the flowmeters was measured before and after operation of the facility, and no change was found. A description of this type of flowmeter and the equations needed to calculate the flow rate are contained in reference 4. No direct flow calibration of these flowmeters was made.

Oil flow rate was measured with a positive displacement meter. This oil meter and associated readout equipment were calibrated on a weight test stand prior to use. Accuracy of the meter was $\pm 1/2$ percent over the range of expected flows and viscosities.

Temperature. - All the thermocouples were made from Chromel-Alumel thermo-

couple wire with ISA (Instrument Society of America) special limit of error ($\pm 3/8$ percent). The thermocouple junctions around the heating and two-phase loops were spot welded to the outside pipe walls, and the wires were insulated with two-hole ceramic beads strapped to the pipe for support. An immersion couple $T_{k,41}$ was installed in the vapor pipe just ahead of the vacuum chamber. This Chromel-Alumel thermocouple was swaged into a 1/16-inch (0.16 cm) outside-diameter insulated sheath and pushed into a thermocouple well. The well was constructed of 0.375-inch (0.952 cm) outside-diameter tubing closed at the end and bent to provide about 2 inches (5.08 cm) of straight tubing in line with the flow.

The temperature drop ΔT_h of the NaK across the boiler was measured with a differential thermopile that produced four times the output of a single differential thermocouple.

The temperatures of the inside and outside walls of the vacuum chamber $T_{w,i}$ and $T_{w,o}$, respectively, were measured by spotwelded thermocouples. The inside wall temperature $T_{w,i}$ is the average of 26 individual thermocouples spotted axially along the inside chamber wall. Some of these thermocouples are shown in figure 6(b). The outside wall temperature $T_{w,o}$ is the average of eight spotwelded thermocouples.

The temperatures of the oil loop were measured with immersion thermocouples. Because of the possibility of stratification within the viscous cooling fluid, flow mixers were installed ahead of the temperature-measuring stations. The oil temperature rise across the vacuum chamber ΔT_c was measured by an immersion differential thermopile, similar to the boiler thermopile.

Pressure. - Pressure readings were taken in all the loops; however, the only pressure readings of interest herein are those measured in the two-phase loop. Pressure readings in the heating and cooling loops were taken mainly to ensure operation within the liquid phase. Pressures in the two-phase loop were measured at four locations: boiler inlet $P_{b,i}$, boiler outlet $P_{b,o}$, radiator inlet and outlet header P_i and P_o , respectively. The entrance pressure drop ΔP_e from inlet header to the center tube of radiator, tube 5, was also measured directly.

The pressure measurements at boiler inlet, boiler outlet, and radiator inlet were made with Bourdon-type pressure gages. These gages use a slack diaphragm as the sensing element and hydraulically transmit the sensed pressure through a NaK capillary to the Bourdon tube. This type of instrument is described in more detail in reference 4. The full-scale range of the gages used was 0 to 50 pounds per square inch absolute (0 to 345 kN/m² abs). These gages were calibrated with the two-phase loop full of liquid potassium. Calibration was accomplished by applying known gas pressures to the inventory tank while maintaining all potassium in the liquid phase and no flow in the system. Gas pressure was measured with a Bourdon-type gage accurate to within 0.1 percent for the range from 0 to 100 pounds per square inch absolute (0 to 689 kN/m² abs). Calibrations

also included the readout equipment. The expected error of the Bourdon-type pressure measurements was ± 0.4 pound per square inch ($\pm 2.8 \text{ kN/m}^2$).

The condensate header pressure P_o was measured with a strain-gage pressure transducer that had a range of 0 to 50 pounds per square inch absolute (0 to 345 kN/m^2 abs). The tube entrance pressure drop ΔP_e was measured by a differential strain-gage transducer with a range of ± 10 pounds per square inch ($\pm 69 \text{ kN/m}^2$) differential. The transducers were rated for use with corrosive fluids at temperatures up to 660° R (367° K). The transducers and the connecting piping had to be heated to a temperature above the freezing point of potassium (600° R ; 333° K). The two transducers were installed in an electrically heated oven regulated to maintain a temperature of 650° R (361° K). The connecting piping, going to the attachment points at the condensing radiator were 0.44-inch (1.12 cm) inside-diameter tubes, holding noncirculating liquid potassium. These lines (fig. 4(c)) were electrically trace heated and shielded with stainless-steel foil to prevent freezing. Suitable valving was used to allow calibration of the strain-gage transducers prior to and during operation. The calibration procedure was the same as that used to calibrate the Bourdon-type gages, already described. The expected error in these strain gage transducer readings was ± 0.2 pound per square inch ($\pm 1.4 \text{ kN/m}^2$).

Electric power. - The electric power supplied to the superheater $Q_{E,s}$ was measured directly by a recording wattmeter with a range of 0 to 10 kilowatts. The electrical input to trace heaters on instrument lines and the condensate return line inside the vacuum chamber $Q_{E,w}$ was measured by ammeters and voltmeters for an assumed power factor of 1.

Condensing Radiator Instrumentation

The condensing radiator was extensively instrumented with thermocouples to obtain conditions on the inlet and outlet headers, longitudinal temperature profiles along each of the nine tubes, and local cross-sectional profiles on tube and fin surfaces at certain locations.

All thermocouples on the radiator surface were made of 28-gage Chromel-Alumel wire swaged inside a 0.0625-inch (0.16 cm) outside-diameter insulated sheath. Typical application of these thermocouples to the surface of the radiator is shown in figure 9. The 0.0625-inch (0.16 cm) sheath was cut off about 1 inch (2.54 cm) from the junction. The bare thermocouple wire was then spotwelded to the desired point of measurement, and a half loop was made in the lead wires to maintain the wire away from the surface. The sheath was strapped to the tube or fin surface for mechanical support. The direction of the thermocouple wire between the junction and the first support point was always parallel to the axis of the tubes. Past the support point, the thermocouples were again

lifted away from the radiator surface.

Header temperatures. - The inlet vapor header had four thermocouples, $T_{k,6A}$ to $T_{k,6D}$ spotwelded to the outside header wall, as shown in figure 10(a). It also had four immersion thermocouples, $T_{k,61}$ to $T_{k,64}$, inserted in the header flowing stream. The plan view of the condensing radiator (fig. 3(a)) shows the location of the immersion probes. The wall thermocouples were placed on the same cross-sectional plane as the measuring junction of the corresponding immersion thermocouples. The condensate outlet header has an immersion probe $T_{k,70}$ inserted in the liquid passage. Because of the size of the header, the well on this probe was straight and inserted in the centerline of the 0.825-inch-diameter (2.10 cm) flow passage from the outlet end of the header.

Longitudinal temperature profiles. - Surface thermocouples were spotwelded near the top and bottom centers of the outer walls of the nine tubes at 8-inch (20.3 cm) intervals. As shown in figure 4(c), the rows of thermocouples were alternately placed at the top and bottom of the tubes, starting at the inlet header with the first row at the top surface. For this purpose, 198 thermocouples were used. Figure 10(a) shows the location of each of these thermocouples. Identification is made by the tube number and the distance in inches (cm) from the inlet of the tube. It should be noted that tube 1 is the tube farthest from the vapor header inlet, while tube 9 is the first to be encountered as the fluid enters the vapor header.

Cross-sectional temperature profiles. - Temperature profiles across the tube and fin were measured at three points on the radiator surface. These locations, labeled A, B, and C, are shown in figure 10(a). The positions of the thermocouples at these points are given in detail in figure 10(b). Each thermocouple is identified by its projected distance from the tube centerline.

Recording Equipment

Temperatures. - All temperature readings from both liquid metal loops were recorded with a central automatic data-recording system at a rate of 40 points per second. The range of this system was 50 millivolts with a resolution of 0.05 millivolt. Oil-loop and chamber-wall temperatures were recorded on 12-inch (30.5 cm) null-balance multi-point recorders with a range of 460° to 1060° R (256° to 589° K) and a resolution of 2° R (1.1° K). Thermopile outputs were read on manually balanced precision potentiometers.

Pressures. - Pressures were continuously recorded during operation. The output of the Bourdon-type volumetric pressure gages was recorded on null-balance strip recorders. The strain-gage pressure transducer outputs were recorded on a multichannel oscillograph.

Flow rates. - The output of the electromagnetic flowmeters was recorded continuously on null-balance recorders. The flow rate in the two-phase loop was also recorded

on the multichannel oscillograph. Oil flow rate was read on a visual display frequency counter.

EXPERIMENTAL PROCEDURE

The purpose of the experimental procedure was to collect steady-state condensing data at three temperature levels, 1700° , 1810° , and 1890° R (944° , 1006° , and 1050° K), over a range of vapor flow rates. In addition, all-liquid runs were made in order to determine the heat losses from the different sections of the test equipment.

The facility was operated continuously for a 10-day period during which the required data were obtained. The procedures used were similar to those of reference 9. A brief description of these procedures is given in this section.

Filling and Starting

The NaK was preheated to 860° R (478° K) in the dump tank before being forced into the heating loop. The heating loop was not preheated as NaK 78 is liquid at normal room temperature. Once the heating loop was filled, the temperature of the circulating NaK was raised to 1260° R (700° K) and was maintained at that level until the two-phase loop was filled with potassium.

Before the two-phase loop could be filled with the clean potassium stored in its dump tank, the entire piping loop was heated electrically higher than 860° R (478° K). The tube walls of the condensing radiator were preheated electrically (see figs. 3(b) and 4(c)) higher than 760° R (422° K). The vacuum chamber walls were kept at 660° R (367° K) by steam heating the circulating oil (fig. 1). The vacuum in the chamber was brought to its operating level of 10^{-3} torr (0.133 N/m²). The two-phase loop was evacuated to a pressure of about 50×10^{-3} torr (6.65 N/m²) to minimize the presence of noncondensable gases in the working fluid. After desired conditions were reached, the dump tank was pressurized with argon gas, the dump valve was opened, and liquid potassium was forced into the system. When potassium appeared in the inventory tank (fig. 1), filling was terminated by closing the dump valve. After the two-phase loop was filled, the temperature of both loops was raised until the temperature in the heating loop exceeded 1400° R (778° K), at which time all the electric trace heaters on the circulating loops were turned off.

All-Liquid Runs

Data were taken after both loops reached operating temperatures, with the two-phase loop fluid entirely in the liquid phase. To obtain heat-loss data, the heating loop was op-

erated at various temperature levels and the two-phase loop at various flow rates. All temperatures around the two-phase loop were allowed to reach a steady-state value before the readings were taken.

Transition from Liquid to Two-Phase Operation

The transition from liquid to two-phase operation was accomplished by heating the liquid potassium to operating temperature at a pressure in excess of the corresponding vapor pressure. Then the pressure in the inventory tank was reduced until saturation conditions were reached in the boiler. As vapor was generated in the two-phase loop, liquid potassium was displaced from the loop into the inventory tank. At no time were noncondensable gases allowed to enter the flowing system.

Condensing Runs

Once two-phase operation was started, the condensing data were taken. The pressure level in the two-phase loop was controlled by adjusting the cover gas pressure on the inventory tank until the desired pressure was obtained at the condensing radiator inlet. Flow rate in the two-phase loop was controlled manually by adjusting the pump voltage and the throttle valve setting. The heat-transfer rate in the boiler was controlled by adjusting the two-phase-loop flow rate and the NaK temperature at the boiler inlet. This temperature was set as required and automatically controlled by the NaK electric heater. All conditions of flow, temperature, and pressure were monitored between recorded data points. Data were taken after all conditions ceased drifting, even though oscillation of some of the variables around their mean values might have persisted. The time that elapsed between successive data points varied from 1/2 to 3 hours.

DATA HANDLING

Data Acquisition

During this investigation, 24 all-liquid runs and 77 two-phase runs were made. All pertinent data are presented in tabular form in tables I to VI. Each run was taken, as indicated in the previous section, after all system variables stopped drifting. For each run, all the temperature sensors connected to the central automatic data recorder were read successively 10 times and averaged. This recording operation took approximately 1.5 minutes. All liquid-metal temperatures presented in the tables are the average of the 10 readings taken for each station. During this interval, a multiple channel oscillo-

graph recording was taken, all instrument charts were marked, and data from nonrecording instruments were read.

The data from the all-liquid runs are presented in table I. Runs L1 to L24, were taken in successive order. Only the data necessary to determine heat losses from the boiler, superheater, chamber walls, vapor pipe, and inlet header are shown in these tables.

Data for the 77 condensing runs are presented in tables II to VI. The runs have been arranged into five logical groups as shown in the following table:

Run	Nominal vapor temperature, °R (°F)	Boiler flow direction	Remarks
1 to 11	1700 (944)	Countercurrent	Arranged in order of increasing flow rates ↓ Chronological sequence of runs taken with one or more tubes plugged
12 to 23	1810 (1006)	Countercurrent	
24 to 49	1810 (1006)	Cocurrent	
50 to 71	1890 (1050)	Countercurrent	
72 to 77	-----	Countercurrent	

The run number is not necessarily dictated by the chronological sequence in which data runs were taken. The order in which the data were taken is indicated by the original run number in the column labeled O-R in tables II to IV.

Data Reduction

The data obtained for the all-liquid and condensing runs were reduced to obtain heat losses, condensing lengths, heat loads, vapor qualities, and pressure drops. The reduced data were then arranged into performance maps and compared with analytical predictions.

The reduction of the all-liquid data into heat losses from different components of the loops as well as heat-transfer rates from the vapor supply pipe and vapor header is discussed in appendix B. The sum of the heat losses from the vapor carrying portion of the liquid-metal loop represented from 5 to 15 percent of the heat-transfer rates obtained during two-phase operation. The heat losses from the vacuum chamber walls ranged from 15 to 20 percent of the radiator heat-transfer rate.

Reduction of the condensing data is detailed in appendix C. Radiator heat-transfer rate was taken as the average of the heat supplied by the heating loop at the boiler and the heat removed by the cooling loop from the vacuum chamber walls when the heat losses from the system determined from the all-liquid data were considered. Condensing

lengths were determined from the radiator temperature profiles. Vapor qualities were determined thermodynamically.

Properties of potassium used in this report were taken from reference 10, as reported in reference 11, and are shown graphically in figure 11. The specific heats of the auxiliary fluids, NaK and cooling oil, appear in figure 12.

Analytical Procedure

Analytical determination of the heat dissipation and pressure drop in the condensing radiator tubes was compared with the experimental data collected. Details of the analytical methods are given in appendix D.

The heat dissipation from the surface of the radiator tube was obtained by applying the two-dimensional relaxation procedure of reference 2 to the cross section of the radiator tube assembly. This method calculates the heat-transfer rate on the cross section based on the varying boundary conditions caused by the change in view factor from point to point along the radiator outside surface. It also yields a surface temperature map along the tube and fin. The basic assumptions made for this analysis were that the inside wall temperature was constant around the perimeter of the tube and equal to the vapor saturation temperature, the emissivity of the outer wall was 0.73, the vacuum chamber walls constituted a blackbody, and the thermal conductivity of the radiator tube and fin material was constant and equal to the value corresponding to the inside wall temperature for each point calculated.

Pressure drops along the tube were calculated by the Lockhart-Martinelli method (ref. 12) on an incremental basis. This method was used to incorporate the varying vapor flow rate (as determined by the heat dissipation rate given by the two-dimensional analysis) and the corresponding momentum recovery. Inlet pressure drops used in the analysis were the experimental values obtained during tests.

RESULTS AND DISCUSSION

Computed results from the 77 experimental condensing runs are presented in tables VII to IX. Some of these data are also presented in graphic form as temperature profiles and performance maps and are compared with analytical predictions in figures 13 to 20.

Temperature Profiles

Longitudinal temperature profiles. - Sample longitudinal temperature profiles from three different runs appear in figure 13. These profiles were plotted from the data given in table IV. In each of the three curves shown, the condensing length is indicated by dashed lines from the point where the surface temperature begins to drop sharply. It is clear from examination of the profiles that addition of extra length as a "safety factor" in the design of a condensing radiator will result in an appreciable change in the temperature of the condensate returning to the system.

A visible indication of the condensing lengths was obtained by the change of color of the radiator tube surface. A black and white print of a color photograph taken during operation of the radiator is shown in figure 14. The only source of light for this picture was that emitted by the radiator surface. The end of each condensing length is the point where the tube changes from white to gray. The gray region is the beginning of the subcooling area, where the temperature is still high enough to impress the film. The remaining length of the radiator tubes, up to 170 inches (432 cm), further subcooled the condensate. This last portion appears black in the photograph because the temperature has dropped below the point where the intensity of the emitted light can register on the film. The inlet vapor header was brighter than the tubes, indicating a higher surface temperature. This difference was a result of the pressure drop across the tube entrances and the thinner walls of the header.

The condensing lengths determined from plots such as figure 13 are summarized in table VII for the nine tubes of the radiator and for all runs. Examination of these values and inspection of photographs such as figure 14 shows that the condensing lengths were not necessarily equal on all nine tubes for a given run. Generally, the condensing lengths in tubes 3 to 8 were very nearly the same, with tubes 1, 2, and 9 having shorter condensing lengths. Tubes 1 and 9 are the outer tubes of the radiator panel, which have a better view of the cool chamber walls; therefore, their heat rejection rate should be higher than the inside tubes. In addition, tubes 1 and 2, which are the farthest away from the vapor inlet end of the header, might have a higher liquid loading than the other tubes as a consequence of the vapor condensation in the header. This additional liquid loading probably results in a lower vapor flow through tubes 1 and 2, contributing to the shorter condensing length.

Visual observation showed that the difference in condensing lengths between tubes was a steady phenomenon with no appreciable "U-tube oscillations" among the tubes. Once a condensing length distribution among tubes was established, it remained constant until operating conditions were changed. This does not mean that the condensing lengths of the tubes were perfectly steady during every run. Visual observation of the bright areas of the tubes, as well as the temperature variations near the interfaces during the

10 readings taken per run, indicated there were small variations in the condensing lengths during some of the runs.

Observation of the interface also indicated that the condensing radiator behaved satisfactorily even with flow in one of the tubes completely stopped and another tube partially blocked, as shown in figure 15. This blockage was caused either by overcooling and freezing of the potassium condensate in the expansion loops during low flow rate runs, or by a deposit of oxides. Flow was later recovered in the two affected tubes by increasing the condensing lengths in the radiator, through an increase in vapor flow rate and a decrease in vapor pressure, and hence temperature. When flow was regained in the blocked tubes, the movement of the interfaces to the new equilibrium condition was very smooth and did not introduce large-scale oscillations in the system.

Cross-sectional temperature profiles. - Data from the cross-sectional temperature profiles at location B for three different runs are presented in figure 16 and compared with corresponding predicted curves. These particular runs were selected as they cover the range of operating temperatures investigated. The vapor-liquid interfaces were downstream of the measuring station, but sufficiently near that the condensate outlet pressure P_o is a good measure of the vapor pressure at location B. The predicted surface temperature curves were taken from the output of the two-dimensional analysis for the assumption that the tube inner wall is at the saturation temperature corresponding to P_o .

The following points can be noted from examination of the data and predicted profiles in figure 16:

(1) The general shape of the temperature profiles agree with the predictions. The surface temperature around the perimeter of the tube is nearly constant and drops sharply along the fin length.

(2) The temperatures on the surface of the tube are lower than predicted, with discrepancy increasing at the higher temperature levels. Thus, a larger temperature difference exists between the vapor bulk temperature and the temperatures registered by the outside tube wall thermocouples. Explanations for this discrepancy can be made by considering a finite condensing heat-transfer resistance at the inside wall, which was neglected, and by assuming errors in the surface thermocouples and emissivity measurements. The condensing film resistance at the heat flux level of these runs, 20 000 to 45 000 Btu per hour per square foot (63 040 to 141 800 W/m^2), however, should not introduce a large temperature drop according to the results of reference 13. The emissivity was measured on test coupons before and after operation, and the values agreed within 4 percent. But, the maximum systemic error due to the application of the tube surface thermocouples was evaluated (see appendix E) and appears to be of considerable magnitude. The thermocouple wires act like pin fins attached at the measuring junction and draw heat away from it, thereby reducing the reading below its real value. For example,

at 1810° R (1006° K), a maximum difference of 25° R (14° K) was calculated.

(3) Measured temperature on the surface of the fin are higher than predicted. One of the factors contributing to this disagreement is the neglect of the weld fillet between the fin and tube in the analytical prediction of temperature distribution. The addition of weld metal at the joint of fin and tube increases the thermal conductance of the fin for the length of the fillet, thereby decreasing the temperature drop due to conduction. Also, the systemic error of the thermocouples applied to the fins is quite different from the systemic error of the thermocouples on the tube wall. The surfaces of the fin thermocouples are exposed to the hotter walls of the tube itself, as well as to the cooler walls of the tank. The heat flux away from the junction in the pin fin formed by the fin thermocouple will be lower than that for the tube wall thermocouples. No attempt was made to evaluate this loss as the complexity of the analysis required to describe the problem is beyond the scope of this report.

(4) Even disregarding errors in temperature measurements on the surface of the fin and tube, the experimental values are within ± 2 percent of the predicted absolute temperature values.

Pressure Drop

Tube entrance pressure drop. - The static pressure drops ΔP_e , measured directly between the inlet header and the entrance region of the center tube of the radiator panel tube 5, are plotted in figure 17 as a function of vapor velocity head at the tube inlet. A least-squares straight-line fit of the data indicates a slope of 2.16. This value represents 1 velocity head converted to velocity pressure, with the remaining pressure change (1.16 VH_t) representing the turning and entrance losses from the vapor inlet header to the tube inlet. All the data points, with the exception of six, fell within 0.1 pound per square inch (0.689 kN/m^2) of the value for the best line. This loss coefficient of 1.16 is much larger than the loss coefficient of 0.1 to be expected for a gas flowing alone through a smooth entrance. The work reported in reference 14 also shows larger losses than expected for the flow of water-air mixtures through rounded entrances.

Overall pressure drop. - The overall pressure drop ΔP across the radiator panel is presented in graphic form in figure 18. These data are shown as a function of vapor flow rate at the tube inlet for the three temperature levels investigated. The overall pressure drop is the difference between the measured static pressures at inlet and outlet headers, and includes the tube entrance pressure drop. Because the points of measurement of the static pressures are in regions of very low velocity, these pressure drops can be considered to be identical to the change in total pressure across the radiator.

The pressure drop increases with an increase in vapor flow rate for any given inlet

vapor temperature. It increases much faster at the low vapor temperatures than at the higher temperatures. Figure 18 also shows two calculated pressure-drop curves for each temperature level superimposed for comparison purposes. The calculated values were obtained by the method described in appendix D for assumed vapor qualities at the tube inlet of both 0.6 and 1.0. The experimental values of pressure drop are larger than predicted, with the values for the 1810° R (1006° K) data having a wider scatter than the rest. This scatter is probably caused by the larger range of inlet vapor qualities covered by the 1810° R (1006° K) data as shown in table VIII. It should be noted also that the pressure drop for the 1810° R (1006° K) data taken with the boiler in cocurrent flow is higher for any vapor flow rate than the corresponding pressure drop for the 1810° R (1006° K) data taken with the boiler in counterflow. This result can be attributed to the lower qualities obtained with the cocurrent boiler for any given vapor flow rate. Comparison of runs 12 to 23 (countercurrent boiler) with runs 24 to 49 (cocurrent boiler) in table VIII indicates this difference in qualities.

Correlation of tube two-phase frictional pressure drop with results from other fluids. - The pressure-drop data obtained during this investigation were converted into frictional pressure drops along the radiator tubes ΔP_F by the method shown in appendix C. This method allows correlation of the potassium condensing pressure-drop data with existing results for condensing Freon-113 and water (presented in ref. 15). The method of reference 15 correlated the two-phase frictional pressure drop in Freon-113 and steam condensers through the use of a single-phase inlet flow parameter $VH_t(L_m/D)$, which neglects the presence of the liquid phase. Figure 19 shows the two-phase frictional pressure drops for potassium plotted as a function of vapor inlet flow parameter, together with the steam and Freon-113 data from reference 15. Figure 19 shows only the potassium data with inlet qualities equal to or greater than 0.65. The agreement with the data from reference 15 is quite good.

Condensing Length

The total condensing lengths of the radiator for all runs are shown in figure 20. The condensing lengths have been plotted as a function of vapor inlet flow rate. The total condensing length L_T is the sum of the individual condensing lengths for all nine tubes of the radiator, as determined from the temperature profiles already discussed. It can be seen that the data scatter for each temperature level is much smaller than for the corresponding overall pressure-drop data.

As with the pressure-drop data, the condensing-length data are plotted with calculated curves superimposed on the data. Four sets of calculated curves, labeled I, II, III, and IV, were obtained for each of the three temperature levels. All four types of curves

were obtained by the method described in appendix D, but with the following particular assumptions:

Method I: Neglects all pressure drops

Vapor temperature is assumed to be constant throughout the condensing length and equal in value to the saturation temperature at the vapor inlet header. These curves are straight-line functions of the inlet vapor flow rate.

Method II: Considers only the effect of the measured entrance pressure drop

The vapor temperature throughout the condensing length is assumed to be constant, but equal to the saturation value corresponding to the vapor pressure at tube inlet after accounting for the entrance pressure drop.

Method III: Considers the effects of tube entrance pressure drop and pressure change along the tube for an assumed tube inlet quality of 1.0

The vapor temperature that determines the local heat flux is assumed to vary in stepwise fashion along the condensing length.

Method IV: Considers the effects of tube entrance pressure drop and pressure change along the tube for an assumed tube inlet quality of 0.6

From examination of figure 20 it can be seen that the experimental data follow the shape of the curves calculated by methods III and IV. This is especially true for the inlet vapor temperature of 1700°R (944°K), where the values obtained from methods III and IV at the higher vapor flow rates are quite different from the results with the simpler assumptions of method I. The difference in calculated values of condensing lengths between methods III and IV is relatively minor and is caused by the lower equilibrium temperature produced by the higher pressure drop of the lower quality case (method IV). The predicted condensing lengths from method III are between 11 and 19 percent shorter than the measured condensing lengths.

Stability

Variations from the steady-state mean conditions of potassium flow rate, inlet and outlet pressures to the radiator panel, and condensing lengths are presented in table IX for all runs. This table shows the variations in two different ways: as an absolute value of the variation from peak to peak Δ and as a percentage of the mean value $(\Delta_i/i_{\text{mean}})\times 100$. These variations are presented as an indication of the stability of the

radiator parameters during "steady-state" operation.

Variations of the flow and radiator inlet and outlet pressure were obtained from oscillograph traces. The condensing length variations were obtained by plotting the longitudinal temperature profile data near the interfaces for all 10 recording cycles and fairing envelope lines around the data. The two intersections of the subcooling section envelope lines with the near-constant condensing temperature line pinpointed the variation in condensing length for that particular tube. The values for the whole radiator panel were the means of the variations for all nine tubes.

The data variation around the steady-state points can be summarized as follows:

Flow rate variation	within ± 15 percent of mean
Inlet pressure variation	within ± 8 percent of mean
Outlet pressure variation	within ± 8 percent of mean
Condensing length variation	within ± 11 percent of mean

Exceptions to these variations are the inlet and outlet pressures for run 53 (± 13 percent of mean) and the condensing length of run 50 (± 24 percent). No attempt has been made to attribute oscillations to any particular component of the two-phase system because of the complexity of the equipment involved.

SUMMARY OF RESULTS

An experimental study was made of the steady-state performance of a multitube, centrally finned, potassium condensing radiator with the following results:

1. A nine-tube centrally-finned radiator was operated as a potassium vapor condenser in a horizontal attitude and in a vacuum environment without encountering operational difficulties at vapor temperatures ranging from 1690° to 1890° R (939° to 1050° K) and vapor flow rates of 122 to 468 pounds per hour (55 to 212 kg/hr).

2. Flow distribution among the nine tubes was somewhat unequal. Outer tubes, the first and last, had the shortest condensing lengths, reflecting the better view factors to the enclosure walls. Tube 1, farthest removed from the vapor inlet, appeared to have a larger liquid loading due to condensation taking place in the vapor header.

3. No U-tube oscillations of flow among the parallel tubes were detected. The unequal distribution of flow among the tubes, as indicated by dissimilar condensing lengths, was not due to fluctuating conditions: for any one particular run the distribution was constant as evidenced by visual observation of condensing lengths.

4. Actual condensing lengths and pressure drops are compared with values predicted from a two-dimensional analysis of the tube cross section in conjunction with Lockhart-Martinelli two-phase pressure drop correlation applied in a stepwise manner along the

tube. Predicted condensing lengths are 11 to 19 percent shorter than measured for a surface emissivity of 0.73.

5. Inlet pressure losses indicate a loss coefficient of 1.16 based on the tube inlet velocity head.

6. Tube two-phase frictional pressure drops for inlet qualities above 0.65 correlate well with steam and Freon-113 condensing data as a direct proportion of an inlet vapor flow parameter, the product of the tube inlet vapor velocity head, and the mean condensing length to diameter ratio.

7. Cross-sectional temperature profiles along the tube and fin surface had the same general shape as predicted, that is, nearly constant around the tube surface and dropping sharply along the fin. All measured temperatures were within 2 percent of the predicted absolute values, with the tube wall temperatures being lower and fin temperatures higher than the prediction.

Lewis Research Center,
National Aeronautics and Space Administration,
Cleveland, Ohio, May 4, 1967,
120-27-04-02-22.

APPENDIX A

SYMBOLS

A	fin length parameter
a	thermocouple radiating length, ft; m
C_f	constant, Fanning friction factor for liquid
C_g	constant, Fanning friction factor for vapor
c_c	specific heat of cooling fluid (HB-40 oil), Btu/(lb)($^{\circ}$ R); J/(kg)($^{\circ}$ K)
c_h	specific heat of heating fluid (NaK 78), Btu/(lb)($^{\circ}$ R); J/(kg)($^{\circ}$ K)
c_k	specific heat of liquid potassium, Btu/(lb)($^{\circ}$ R); J/(kg)($^{\circ}$ K)
D	tube inside diameter, in. ; cm
d	thermocouple diameter, ft; m
F	view factor
f_f	Fanning friction factor for liquid
f_g	Fanning friction factor for vapor
$G_{g,t}$	potassium vapor mass flow rate at tube inlet, lb/(hr)(ft ²); kg/(hr)(m ²)
g_c	conversion factor, 32.2 lb mass/(lb force) [(ft)/(sec) ²]
h_f	potassium liquid enthalpy, Btu/lb; J/kg
h_{fg}	potassium heat of vaporization, Btu/lb; J/kg
k_{th}	thermocouple thermal conductivity, Btu/(hr)(ft)($^{\circ}$ R); W/(m)($^{\circ}$ K)
k_w	wall thermal conductivity, Btu/(hr)(ft)($^{\circ}$ R); W/(m)($^{\circ}$ K)
L_{last}	condensing length of last increment, in. ; cm
L_m	mean condensing length, $L_T/9$, in. ; cm
L_{max}, L_{min}	longest and shortest tube condensing lengths in any run, in. ; cm
L_n	condensing length of individual tube, where $n = 1, 2, \dots, 9$, in. ; cm
L_T	total radiator condensing length, in. ; cm
N	number of radiator tubes in parallel
O-R	original run number
ΔP	overall header to header radiator pressure drop, psi; kN/m ²

$P_{b, i}$	potassium static pressure at boiler inlet, psia; kN/m^2 abs
$P_{b, o}$	potassium static pressure at boiler outlet, psia; kN/m^2 abs
ΔP_e	pressure drop across radiator tube entrance, psi; kN/m^2
ΔP_F	radiator tube two-phase frictional pressure drop, psi; kN/m^2
P_i	potassium static pressure at radiator vapor inlet header, psia; kN/m^2 abs
P_{last}	potassium static pressure at last condensing increment, psia; kN/m^2 abs
P_o	potassium static pressure at radiator condensate header outlet, psia; kN/m^2 abs
P_t	potassium static pressure at radiator tube inlet, psia; kN/m^2 abs
ΔP_M	pressure change due to momentum recovery, psi; kN/m^2
$(\Delta P/\Delta L)_F$	two-phase frictional pressure-drop gradient, $(\text{lb/ft}^2)/\text{ft}$; $(\text{kN/m}^2)/\text{m}$
$(\Delta P/\Delta L)_f$	liquid frictional pressure-drop gradient, $(\text{lb/ft}^2)/\text{ft}$; $(\text{kN/m}^2)/\text{m}$
$(\Delta P/\Delta L)_g$	vapor frictional pressure-drop gradient, $(\text{lb/ft}^2)/\text{ft}$; $(\text{kN/m}^2)/\text{m}$
$Q_{b, f}$	sensible heat input to liquid potassium in boiler, Btu/hr; W
Q_c	heat removed by cooling oil, Btu/hr; W
$Q_{E, s}$	electric heat input to superheater, Btu/hr; W
$Q_{E, w}$	electric heat input to vacuum chamber trace heaters, Btu/hr; W
Q_H	vapor header and pipe heat-transfer rate, $Q_{L, q} + Q_{L, H}$, Btu/hr; W
Q_h	heat supplied by heating loop at boiler, Btu/hr; W
Q_i	condensing heat-transfer rate at radiator header inlet, mean value, Btu/hr; W
$Q_{i, c}$	condensing heat-transfer rate at radiator header inlet, from heat rejection considerations, Btu/hr; W
$Q_{i, h}$	condensing heat-transfer rate at radiator header inlet, from heat supply considerations, Btu/hr; W
$Q_{L, b}$	boiler shell heat loss, Btu/hr; W
$Q_{L, H}$	vapor header heat loss, Btu/hr; W
$Q_{L, p}$	vapor pipe heat loss between superheater and vacuum chamber, Btu/hr; W
$Q_{L, q}$	vapor pipe heat loss inside vacuum chamber, Btu/hr; W
$Q_{L, s}$	superheater heat loss, Btu/hr; W
$Q_{L, w}$	vacuum chamber walls heat loss, Btu/hr; W

$Q_{M,f}$	sensible heat removed from potassium liquid at radiator, Btu/hr; W
Q_t	condensing heat-transfer rate in radiator tubes, Btu/hr; W
Q_{th}	heat loss from thermocouple wire to chamber walls, Btu/hr; W
$\Delta Q/\Delta L$	incremental heat load from radiator tube surface, Btu/(hr)(8-in. length); W/(20.3-cm length)
q_t	condensing heat flux based on inside area of radiator tubes, Btu/(hr)(ft ²); W/m ²
Re_f	superficial Reynolds number in radiator tubes for potassium liquid
Re_g	superficial Reynolds number in radiator tubes for potassium vapor
T	true surface temperature, °R; °K
T_a	ambient temperature near vacuum chamber, °R; °K
$T_{c,o}$	coolant temperature (oil) at vacuum chamber outlet, °R; °K
$T_{h,j}$	heating loop temperatures, where j denotes station number as shown in fig. 8, °R; °K
$T_{k,j}$	potassium (two-phase) loop temperatures, where j denotes station number as shown in figs. 8 and 10(a), °R; °K
$T_{m,b}$	mean boiler temperature, °R; °K
$T_{m,g}$	mean vapor inlet header immersion temperature, °R; °K
$T_{m,H}$	mean vapor header wall temperature, °R; °K
$T_{m,p}$	mean vapor pipe temperature between superheater and vacuum chamber, °R; °K
$T_{m,s}$	mean superheater temperature, °R; °K
T_{sat}	vapor saturation temperature at vapor header pressure, °R; °K
T_{th}	actual thermocouple temperature reading, °R; °K
$T_{t,j}$	radiator surface temperature at tube station 1 and tube number j, where j = 1 to 9 (see fig. 10(a)), °R; °K
$T_{w,i}$	vacuum chamber inside wall temperature, average of 26 thermocouples, °R; °K
$T_{w,o}$	vacuum chamber outside wall temperature, average of 8 thermocouples, °R; °K
ΔT_c	coolant (oil) temperature rise across vacuum chamber as measured by differ- ential thermopile, °R; °K

ΔT_h	heating fluid (NaK) temperature drop across boiler as measured by differential thermopile, $^{\circ}\text{R}$; $^{\circ}\text{K}$
u	Reynolds number exponent in Fanning friction factor for potassium liquid
$V_{g,t}$	potassium vapor velocity at tube inlet, ft/sec; m/sec
VH_t	potassium vapor velocity head at tube inlet, psi; N/m^2
v	Reynolds number exponent in Fanning friction factor for potassium vapor
W_c	coolant (oil) flow rate, lb/hr; kg/hr
$W_{g,t}$	potassium vapor flow rate at radiator tube inlet, $W_k(x_t)$, lb/hr; kg/hr
W_h	heating (NaK) fluid flow rate, lb/hr; kg/hr
W_k	potassium total flow rate, lb/hr; kg/hr
X	distance of cross-sectional profile thermocouples from tube centerline along diameter bisecting fin, in.; cm
x_i	potassium vapor quality at inlet to vapor header
x_m	potassium vapor quality, mean value for 8-in. (20.3 cm) increment
x_t	average potassium vapor quality at radiator tube inlets
Δx	change in quality for each increment in length
Δ	difference between maximum and minimum value during any run, appropriate units
ϵ_{th}	surface thermocouple total hemispherical emissivity
η	fin efficiency
μ_f	potassium liquid viscosity, lb/(hr)(ft); $(\text{N})(\text{sec})/\text{m}^2$
μ_g	potassium vapor viscosity, lb/(hr)(ft); $(\text{N})(\text{sec})/\text{m}^2$
ρ_f	potassium liquid density, lb/ft ³ ; kg/m ³
ρ_g	potassium vapor density, lb/ft ³ ; kg/m ³
σ	Stefan-Boltzmann constant, 0.1713×10^{-8} Btu/(ft ²)(hr)($^{\circ}\text{R}^4$); 5.6697×10^{-8} W/(m ²)($^{\circ}\text{K}^4$)
ϕ_g	two-phase pressure drop multiplier
χ_g	Lockhart-Martinelli parameter

APPENDIX B

ALL-LIQUID DATA REDUCTION

The all-liquid data presented in table I were used to determine heat losses that must be taken into account to calculate the heat load on the condensing radiator during the two-phase runs. In every case, the major assumption was made that heat fluxes were controlled by the large resistances introduced by magnesia insulation, radiation shielding, natural convection film resistance on the air side, etc. rather than the small liquid or two-phase film resistances to heat transfer.

The sections of interest were

- (1) Boiler shell
- (2) Superheater
- (3) Vapor pipe between the superheater and vacuum chamber
- (4) Vacuum chamber walls

In addition, the heat dissipation from the shielded section of the vapor pipe inside the vacuum chamber and from the vapor inlet header was calibrated so that loading of the radiator tubes during the two-phase operation could be determined.

Heat Losses

Boiler shell. - The boiler heat losses $Q_{L, b}$ were obtained from figure 21. The heat supplied by the heating loop Q_h was plotted against the heat removed from the boiler by the liquid potassium $Q_{b, f}$. A 45° line (dashed line in fig. 21) was drawn through the data points, and the vertical displacement of this line from the "no heat loss line" ($Q_h = Q_{b, f}$) was taken to be the mean boiler shell heat loss over the whole temperature range of interest. This method was used in preference to a heat balance because of the large errors that would be inherent in the calculation of the small difference between two large numbers. The heat-transfer rates were determined by

$$Q_h = W_h c_h \Delta T_h; \left[Q_h = \frac{W_h c_h}{3600} \Delta T_h \right] \quad (B1)$$

and

$$Q_{b, f} = W_k c_k (T_{k, 2} - T_{k, 1}); \left[Q_{b, f} = \frac{W_k}{3600} c_k (T_{k, 2} - T_{k, 1}) \right] \quad (B2)$$

The specific heats were evaluated at the arithmetic mean of the temperatures of each stream;

$$\frac{T_{k, 1} + T_{k, 2}}{2}$$

for the potassium stream and

$$T_{m, b} = T_{h, 2} - \frac{1}{2(\Delta T_h)} \quad (B3)$$

for the NaK stream.

Superheater. - The superheater heat losses $Q_{L, s}$ were calculated from the flow rate and temperature drop of the liquid potassium through the superheater after accounting for the electrical energy added in that component:

$$Q_{L, s} = Q_{E, s} + W_k c_k (T_{k, 2} - T_{k, 3}); \left[Q_{L, s} = Q_{E, s} + \frac{W_k}{3600} c_k (T_{k, 2} - T_{k, 3}) \right] \quad (B4)$$

The values of heat loss thus obtained were plotted in figure 22 against the arithmetic mean temperature in the superheater:

$$T_{m, s} = \frac{T_{k, 2} + T_{k, 3}}{2} \quad (B5)$$

This value of mean temperature was also used to evaluate the corresponding value of c_k .

Vapor pipe between superheater and vacuum chamber. - The heat loss from this length of vapor-carrying pipe $Q_{L, p}$ was considered separately from the superheater because of the different type of insulation on it and the lack of an electrical heat input

$$Q_{L, p} = W_k c_k (T_{k, 3} - T_{k, 4}); \left[Q_{L, p} = \frac{W_k}{3600} c_k (T_{k, 3} - T_{k, 4}) \right] \quad (B6)$$

with the value of c_k evaluated at a mean temperature

$$T_{m, p} = \frac{T_{k, 3} + T_{k, 4}}{2} \quad (B7)$$

As before, the results of equations (B5) and (B6) were plotted in figure 23.

Vacuum chamber walls. - The heat loss from the vacuum chamber walls $Q_{L,w}$ was calculated as the difference between the heat given off by the liquid potassium flowing in the radiator through the chamber, plus the electric heat supplied to the instrument line trace heaters, and the heat removed from the chamber walls by the cooling oil

$$\left. \begin{aligned} Q_{L,w} &= W_k c_k (T_{k,4} - T_{k,8}) + Q_{E,w} - W_c c_c (\Delta T_c); \\ \left[Q_{L,w} &= \frac{W_k}{3600} c_k (T_{k,4} - T_{k,8}) + Q_{E,w} - \frac{W_c}{3600} c_c (\Delta T_c) \right] \end{aligned} \right\} \quad (B8)$$

where c_k was taken at the mean value of $T_{k,4}$ and $T_{k,8}$. These heat losses are plotted in figure 24 as a function of the temperature difference between the outside wall of the chamber and the ambient room temperature $T_{w,o} - T_a$.

The straight lines drawn through the heat loss graphs (figs. 22 to 24) represent least-square fits of the data. These lines were used in correcting the heat loads during the two-phase runs.

Heat Dissipation From Vapor Inlet Pipe and Inlet Header Inside Vacuum Chamber

The vapor-carrying pipes inside the vacuum chamber ahead of the finned tubes are also radiating members. It is necessary to determine how much heat they radiate in order to determine the heat transfer in the tubes during condensing runs. The vapor inlet pipe from the vacuum chamber pass-through to the inlet header is wrapped with bright stainless-steel foil radiation shields and has a small heat flux. The vapor inlet header on the contrary, is unshielded and has the same high emissivity as the radiator tubes, so that it has as large a heat flux as the tubes. The heat losses on the two sections were computed separately from the liquid run data because of the dissimilarity of conditions.

The heat loss from the inlet vapor pipe was calculated from

$$Q_{L,q} = W_k c_k (T_{k,4} - T_{k,5}); \left[Q_{L,q} = \frac{W_k}{3600} c_k (T_{k,4} - T_{k,5}) \right] \quad (B9)$$

with c_k evaluated at $T_{k,4}$ (as the difference between the two temperatures was relatively small). The values of $Q_{L,q}$ are plotted as a function of $T_{k,4}$ in figure 25.

The heat load from the vapor inlet header was computed as

$$Q_{L,H} = W_k c_k \left(T_{k,5} - \sum_{j=1}^9 \frac{T_{t,j}}{9} \right); \left[Q_{L,H} = \frac{W_k}{3600} c_k \left(T_{k,5} - \sum_{j=1}^9 \frac{T_{t,j}}{9} \right) \right] \quad (B10)$$

The results of equation (B10) were plotted as a function of the header mean outside wall temperature $T_{m,H}$ in figure 26. The value of $T_{m,H}$ was determined as

$$T_{m,H} = \frac{(T_{k,6A} + T_{k,6B} + T_{k,6C} + T_{k,6D})}{4} \quad (B11)$$

The heat losses from this area of the radiator panel must be known during condensing runs to determine radiator tube heat loads. During condensing, the vapor temperature along the vapor inlet pipe and inlet header will be nearly constant, as there is practically no pressure drop at the low velocities existing in the large diameter pipe and header. Therefore, the most useful way of presenting the heat losses from the vapor inlet pipe and header is as a combined heat loss as a function of vapor saturation temperature. Because $T_{k,4}$ is very close to the value of vapor saturation temperature, figure 25 already represents the heat loss of the vapor inlet pipe as a function of vapor saturation temperature. The abscissa of figure 26, $T_{m,H}$, can be converted to vapor saturation temperature through the use of figure 27. (Fig. 27 is a plot of header immersion temperature, $T_{m,g}$, against mean header wall temperature $T_{m,H}$ obtained from the condensing runs.) With both heat losses now as a function of vapor saturation temperature, they can be added directly to obtain the combined inlet pipe and vapor header loss Q_H as a function of vapor saturation temperature shown in figure 28.

APPENDIX C

CONDENSING DATA REDUCTION

The data obtained during two-phase operation were reduced into parameters that could be arranged into performance maps. The values calculated from the data listed in tables II to VII were

- (1) Condensing length
- (2) Total radiator condensing heat-transfer rate
- (3) Radiator tubes condensing heat-transfer rate
- (4) Tube inlet vapor velocity and velocity head
- (5) Pressure drop

Condensing Length

The individual condensing length L_n for each of the nine tubes was obtained from plots of the surface temperatures measured every 8 inches (20.3 cm) along the entire length of the radiator tubes. Samples of these temperature profiles are shown in figure 13. The end of condensation has been assumed to occur at the point of intersection of the two lines of widely dissimilar slopes drawn through the temperatures. The condensing length of the individual tubes L_n where $n = 1$ to 9, is the distance from the radiator inlet header to the point of intersection mentioned previously.

The total condensing length for a run L_T is the sum of the individual condensing lengths in the nine tubes

$$L_T = \sum_{n=1}^9 L_n \quad (C1)$$

and the mean condensing length for any run is obtained by

$$L_m = \frac{L_T}{9} \quad (C2)$$

The temperature profiles were drawn from the data given in table IV. These readings, in turn, were averages of 10 individual readings taken successively over a time span of 90 seconds under steady-state conditions. Also computed, was the discrepancy between the shortest condensing length L_{\min} and the longest condensing length L_{\max} for each

run. The values of L_n , L_T , L_m , and $L_{\max} - L_{\min}$ are shown for all the condensing runs in table VII.

Total Radiator Condensing Heat-Transfer Rate

The inlet vapor flow rate $W_k x_i$ is used in this report as the measure of the condensing heat-transfer rate handled by the radiator. In all runs, condensation was complete within the radiator. The vapor flow rate at the radiator header inlet was obtained from

$$W_k x_i = \frac{Q_i}{h_{fg}}; \left[W_k x_i = \frac{3600 Q_i}{h_{fg}} \right] \quad (C3)$$

where h_{fg} is the value obtained from figure 11(a) corresponding to the inlet temperature $T_{k,4}$. Equation (C3) also yields the value of x_i . The value of Q_i used was the average of the corrected values of the heat input from the heating loop and the heat removed by the cooling loop:

$$Q_i = \frac{Q_{i,h} + Q_{i,c}}{2} \quad (C4)$$

The radiator inlet condensing heat-transfer rate determined from the heat input is

$$Q_{i,h} = Q_h - Q_{b,f} + Q_{E,s} - (Q_{L,s} + Q_{L,b} + Q_{L,p}) \quad (C5)$$

where

$$Q_h = W_h c_h \left[\frac{|(T_{h,1} - T_{h,2})| + \Delta T_h}{2} \right]; \left[Q_h = \frac{W_h c_h}{3600} \left[\frac{|(T_{h,1} - T_{h,2})| + \Delta T_h}{2} \right] \right] \quad (C6)$$

is the total heat input from the heating loop, with c_h taken at the mean temperature;

$$Q_{b,f} = W_k (h_{f,2} - h_{f,1}); \left[Q_{b,f} = \frac{W_k}{3600} (h_{f,2} - h_{f,1}) \right]$$

is the sensible heat added to the liquid potassium; the values of h_f are the potassium liquid enthalpies corresponding to $T_{k,2}$ and $T_{k,1}$, respectively; $Q_{E,s}$ is the measured

electrical energy input at the superheater; the heat loss terms $Q_{L,s}$ and $Q_{L,p}$ are obtained from figures 22 and 23 at temperatures, $T_{k,3}$ and $T_{k,4}$ respectively; and $Q_{L,b}$ is taken as 9000 Btu per hour (2.6 kW), as indicated by figure 21.

The radiator inlet condensing heat-transfer rate calculated from the heat removed was

$$Q_{i,c} = Q_c - Q_{r,f} + Q_{L,w} - Q_{E,w} \quad (C8)$$

where

$$Q_c = W_c c_c \Delta T_c; \left[Q_c = \frac{W_c}{3600} c_c \Delta T_c \right] \quad (C9)$$

is the heat removed by the oil from the vacuum chamber walls;

$$Q_{r,f} = W_k (h_{f,4} - h_{f,8}); \left[Q_{r,f} = \frac{W_k}{3600} (h_{f,4} - h_{f,8}) \right] \quad (C10)$$

is the sensible heat released by the potassium in the radiator with the liquid enthalpies being taken at $T_{k,4}$ and $T_{k,8}$, respectively; $Q_{L,w}$ is the heat loss from the vacuum chamber walls, obtained from figure 25 for the corresponding values of $(T_{w,o} - T_a)$; and $Q_{E,w}$ is the electric energy added to the instrument tubes and condensate header and return line within the vacuum chamber. The agreement obtained between the values of $Q_{i,h}$ and $Q_{i,c}$ is shown in the following table as a percentage variation from the mean value, Q_i :

Variation (\pm) from mean, percent	Number of runs
0 to 2	9
2 to 4	20
4 to 6	28
6 to 8	17
>8	3

The values of x_i obtained from equation (C3) are tabulated in table VIII.

Radiator Tubes Condensing Heat-Transfer Rate

The condensing heat-transfer rate dissipated by the radiator tubes differs from the total radiator condensing heat-transfer rate by the amount of heat lost to the vacuum tank by the shielded vapor pipe and the unshielded vapor inlet header. The heat loss from this section of the radiator was determined from the all-liquid runs in appendix B, and the results appear in figure 28. The header and pipe heat loss Q_H is obtained from figure 28 for the corresponding value of $T_{m, g}$ where

$$T_{m, g} = \frac{T_{k, 61} + T_{k, 62} + T_{k, 63} + T_{k, 64}}{4} \quad (C11)$$

The quality at the tube inlet is determined from

$$x_t = x_i - \frac{Q_H}{W_k h_{fg}}; \left[x_t = x_i - \frac{3600 Q_h}{W_k h_{fg}} \right] \quad (C12)$$

Any change in quality due to the expansion into the tubes was neglected as being of small magnitude. The values of tube inlet quality x_t , which together with the total flow W_k and the pressure level determine the condensing heat-transfer rate imposed on the radiator tubes, are tabulated in table VIII. Also shown are the values of heat-transfer rate Q_t and the average heat flux q_t , which are, respectively,

$$Q_t = W_k x_t h_{fg} = W_{g, t} h_{fg}; \left[Q_t = \frac{W_k}{3600} x_t h_{fg} = \frac{W_{g, t}}{3600} h_{fg} \right] \quad (C13)$$

and

$$q_t = \frac{Q_t}{\pi D L_T} (144); \left[q_t = \frac{Q_t}{\pi D L_T} 10^4 \right] \quad (C14)$$

where $D = 0.500$ inch (1.27 cm).

Tube Inlet Vapor Velocity and Velocity Head

The inlet vapor velocity $V_{g, t}$ was calculated from the tube diameter, inlet vapor

flow rate $W_{k,t}$, and the static pressure at the tube inlet. The static pressure was obtained from the measured inlet vapor header pressure and tube entrance pressure drop. For calculating this velocity, it was assumed that

- (1) Vapor occupied the whole area of the tubes, that is, any liquid flow was neglected.
- (2) Flow distribution was equal among the nine parallel tubes.

The value of inlet velocity was, then

$$V_{g,t} = \frac{4(144)}{3600\pi D^2 N} \left(\frac{W_{k,t}}{\rho_{g,t}} \right); \left[V_{g,t} = \frac{4(10)^4}{3600\pi D^2 N} \frac{W_{k,t}}{\rho_{g,t}} \right] \quad (C15)$$

where the number of tubes N was 9 for all the runs with the exception of runs 72 to 77. In these runs, one or more of the tubes were obviously plugged, as shown by the condensing length data of table VII. With the vapor inlet velocity calculated by equation (C15), the inlet velocity head was also calculated for all the runs

$$VH_t = \frac{\rho_{g,t}(V_{g,t})^2}{(144)2g_c}; \left[VH_t = \frac{\rho_{g,t}(V_{g,t})^2 \times 10^{-3}}{2} \right] \quad (C16)$$

The values of $V_{g,t}$ and VH_t are also tabulated in table VIII.

Pressure Drops

Overall pressure drop: The overall pressure drop ΔP was calculated from the difference of the absolute pressure readings taken at the inlet and outlet headers. These static pressure readings were taken in areas of low velocity and therefore they closely represent the total pressure at these points:

$$\Delta P = P_i - P_o \quad (C17)$$

Tube inlet pressure: The tube inlet pressure P_t used to calculate the properties at the tube inlet was obtained from

$$P_t = P_i - \Delta P_e \quad (C18)$$

where ΔP_e was the measured value from the differential pressure transducer connected across the entrance of tube 5.

Tube frictional pressure drop: The tube frictional pressure drop ΔP_F was evaluated from

$$\Delta P_F = (P_t - P_o) + \Delta P_M \quad (C19)$$

where ΔP_M is the momentum pressure recovery. For complete condensation, the momentum pressure at the liquid outlet is negligible and

$$\Delta P_M = 2VH_t \quad (C20)$$

can be substituted.

APPENDIX D

ANALYTICAL METHODS USED TO PREDICT PERFORMANCE OF CONDENSING RADIATOR

Predicted performance curves for the condensing radiator are used in figures 16, 18, and 20 for comparison with the experimental results. These predicted curves were obtained from a combination of calculations of the heat dissipation characteristics of the fin-tube cross section and the pressure changes incurred by the two-phase potassium vapor as it condensed along the tubes.

Heat Dissipation

The two-dimensional relaxation procedure used to calculate the heat dissipation from the radiator tube cross section is described in detail in reference 2. It utilizes a digital computer program to calculate the temperature distribution throughout the tube and fin, including the outer surface. Once the two-dimensional temperature distribution is determined, the total heat flow per unit axial length of the fin-tube combination is obtained by integrating along the surface.

The output from the program consists of (1) a temperature network, of which only the surface temperatures are of interest to the present work, and (2) a heat dissipation per unit axial length of the finned tube. The following data, particular to the condensing radiator fin-tube configuration, were fed into the program just outlined:

Inside tube diameter, in. (cm)	0.500 (1.27)
Outside tube diameter, in. (cm)	1.34 (3.40)
Fin thickness, in. (cm)	0.082 (0.208)
Fin length, in. (cm)	0.84 (2.13)
Wall material	Stainless steel, type 316
Surface emissivity	0.73
Sink temperature, °R (°K)	650 (361)

Outputs were obtained for specified inside tube wall temperatures of 1500⁰, 1700⁰, 1800⁰, and 1900⁰ R (833⁰, 944⁰, 1000⁰, and 1055⁰ K) for the assumption that the thermal conductivity of the stainless steel throughout the cross section is constant at the value corresponding to the specified inside wall temperature.

The surface temperature distribution along the tube and fin obtained from the computer outputs is shown in figure 29 as a temperature map, with the projected distance

from the centerline of the tube being used as a parameter. These values were used to develop the predicted surface temperature profiles (the solid lines in fig. 16) by assuming the inside wall temperature to be the saturation temperature at that location.

The heat-transfer rates obtained from the two-dimensional procedure are plotted in figure 30. They are plotted as $\Delta Q/\Delta L$, the heat dissipation for an 8-inch (20.3 cm) increment of radiator tube length. Figure 30 was used to calculate predicted condensing lengths, with the assumption that the inside wall temperature is equal to the vapor saturation temperature; that is, the resistance to heat transfer inside the tube is negligible.

Pressure Drop

The predicted pressure drops were obtained from

$$\Delta P = \Delta P_e + (\Delta P_F - \Delta P_M) \quad (D1)$$

where the entrance pressure drop ΔP_e was obtained from the experimental data shown in figure 17. The values of $\Delta P_F - \Delta P_M$ were developed through a stepwise application of the Lockhart-Martinelli method (ref. 12) along the condensing length of the tube in increments of 8 inches (20.3 cm). The following assumptions were made:

(1) All thermodynamic properties of the fluid were constant for each 8-inch (20.3 cm) increment, at the values corresponding to the vapor pressure at the beginning of the increment.

(2) The heat dissipated from each 8-inch (20.3 cm) increment was obtained from figure 30 for the saturation temperature corresponding to the vapor pressure at the beginning of the increment.

(3) The vapor and liquid flow rates used in calculations were assumed to be constant at the arithmetic mean values for that increment.

(4) The momentum of the liquid phase in each increment was neglected.

(5) The quality of potassium vapor at tube inlet was assumed to be either 1.0 or 0.6. Two separate pressure-drop curves were obtained, one for each assumption of inlet quality.

(6) The change in heat of vaporization with pressure was neglected. The value of h_{fg} at the vapor header conditions was used.

(7) The vapor and liquid phases were assumed to be in equilibrium throughout.

Curves of pressure drop as a function of inlet vapor flow rate were calculated for various constant inlet header saturation temperatures and are shown in figure 18.

Step 1. - The first step in each set of calculations was the evaluation of the total condensing heat load

$$Q_t = W_{k,t} x_t h_{fg} \quad (C13)$$

where h_{fg} was taken at the selected value of P_i , the vapor inlet header pressure.

Step 2. - The second step consisted in selecting the proper value of ΔP_e from the experimental data of figure 17 by a trial-and-error method. A velocity head at the tube inlet was obtained from

$$VH_t = \frac{\rho_{g,t} (V_{g,t})^2}{(144)2g_c}; \left[VH_t = \frac{\rho_{g,t} (V_{g,t})^2}{2} \right] \quad (C16)$$

where $V_{g,t}$ was calculated from equation (C15), using the saturated fluid properties at the values corresponding to P_i . From this value of velocity head, a value of ΔP_e was determined from figure 17 and the velocity head, equation (C16), was refigured for the properties corresponding to

$$P_t = P_i - \Delta P_e \quad (D2)$$

This procedure was repeated until the values of ΔP_e and P_t converged to unique values.

Step 3. - Once the static pressure value at the beginning of the first 8-inch (20.3 cm) increment of tube P_t was established, the next step consisted in determining the pressure change and fluid flow changes in that increment. The saturation temperature corresponding to P_t was used to specify the fluid properties (μ_g , μ_f , ρ_g , and ρ_f) to be used in the first increment. This value of temperature was also used to obtain the value of $\Delta Q/\Delta L$ from figure 30 applying to the first increment. The change in quality in the first increment was

$$(\Delta x)_1 = \frac{\Delta Q}{W_{k,t} h_{fg}}; \left[(\Delta x)_1 = \frac{3600 \Delta Q}{W_{k,t} h_{fg}} \right] \quad (D3)$$

and the mean quality over this span was

$$(x_m)_1 = x_t - \frac{(\Delta x)_1}{2} \quad (D4)$$

The superficial Reynolds numbers of the liquid and vapor phases were determined, as if each phase occupied the tubes alone, by using the mean value of quality determined from equation (D4):

$$\text{Re}_f = \left[\frac{4(12)W_k}{\pi DN} \right] \frac{1 - x_m}{\mu_f}; \left[\text{Re}_f = \frac{4(100)}{3600} \left(\frac{W_k}{\pi DN} \right) \frac{1 - x_m}{\mu_f} \right] \quad (\text{D5})$$

$$\text{Re}_g = \left[\frac{4(12)W_k}{\pi DN} \right] \frac{x_m}{\mu_g}; \left[\text{Re}_g = \frac{4(100)}{3600} \left(\frac{W_k}{\pi DN} \right) \frac{x_m}{\mu_g} \right] \quad (\text{D6})$$

The values of Reynolds number determined which of the four regimes indicated by reference 12 should be used in calculating the pressure drop. Any value of Reynolds number below 2000 for either stream was considered viscous; for 2000 and above, the flow was considered turbulent. The frictional pressure drop was calculated by the Lockhart-Martinelli method, where

$$\left(\frac{\Delta P}{\Delta L} \right)_F = \phi_g^2 \left(\frac{\Delta P}{\Delta L} \right)_g \quad (\text{D7})$$

$$\phi_g^2 \propto \chi_g^2 \quad (\text{D8})$$

$$\chi^2 = \frac{\left(\frac{\Delta P}{\Delta L} \right)_f}{\left(\frac{\Delta P}{\Delta L} \right)_g} \quad (\text{D9})$$

and $(\Delta P/\Delta L)_f$ and $(\Delta P/\Delta L)_g$ are the single-phase Fanning frictional pressure drops calculated as if each phase were flowing alone in the channel. From the Fanning equation for frictional pressure drop

$$\left(\frac{\Delta P}{\Delta L} \right)_f = 2(12)f_f \frac{\rho_f V_f^2}{Dg_c}; \left[\left(\frac{\Delta P}{\Delta L} \right)_f = \frac{2}{10} f_f \frac{\rho_f V_f^2}{D} \right] \quad (\text{D10})$$

$$\left(\frac{\Delta P}{\Delta L} \right)_g = 2(12)f_g \frac{\rho_g V_g^2}{Dg_c}; \left[\left(\frac{\Delta P}{\Delta L} \right)_g = \frac{2}{10} f_g \frac{\rho_g V_g^2}{D} \right] \quad (\text{D11})$$

where

$$f_f = \frac{C_f}{(\text{Re})_f^u} \quad (\text{D12})$$

$$f_g = \frac{C_g}{(\text{Re})_g^v} \quad (\text{D13})$$

Substituting the values from equations (D10) to (D13) into equation (D9) and incorporating the proper values of velocities result in the following relation:

$$\chi^2 = \frac{C_f}{C_g} \left(\frac{\text{Re}_g^v}{\text{Re}_f^u} \right) \left(\frac{\rho_g}{\rho_f} \right) \frac{(1 - x_m)^2}{x_m^2} \quad (\text{D14})$$

The values of C_f , C_g , u , and v depend on the magnitude of the Reynolds number as an indication of the flow regimes:

Reynolds number		Fanning friction factor		Reynolds number exponent for Fanning friction factor	
Liquid, Re_f	Vapor, Re_g	Liquid, C_f	Vapor, C_g	Liquid, u	Vapor, v
<2000	<2000	16	16	1	1
<2000	\geq 2000	16	.046	1	.2
\geq 2000	<2000	.046	16	.2	1
\geq 2000	\geq 2000	.046	.046	.2	.2

The relations (ref. 12) between φ^2 and χ^2 are plotted in figure 31 for the four regimes. The proper value of φ^2 was obtained from this figure after calculating the value of χ^2 applicable to the interval. The pressure drop per unit length was obtained for the increment from equation (D7), with the value of $(\Delta P/\Delta L)_g$ obtained as per equation (D11). Then, the frictional pressure drop over the increment of 8 inches (20.3 cm) was

$$\Delta P_F = \left(\frac{\Delta P}{\Delta L} \right)_F \left(\frac{8}{12} \right) \left(\frac{1}{144} \right); \left[\Delta P_F = 0.203 \left(\frac{\Delta P}{\Delta L} \right)_F \right] \quad (\text{D15})$$

The momentum pressure recovery occurring in the 8-inch (20.3 cm) increment due to condensing of the vapor was

$$\Delta P_M = \frac{\rho_{g,t} V_{g,t}^2}{144g_c} - \frac{\rho_{g1} V_{g1}^2}{144g_c}; \left[\Delta P_M = \frac{\rho_{g,t} V_{g,t}^2}{1000} - \frac{\rho_{g1} V_{g1}^2}{1000} \right] \quad (D16)$$

With invariant physical properties assumed over the interval, equation (D16) becomes

$$\Delta P_M = 1.106 \times 10^{-7} \frac{W_k^2}{\rho_{g,t}} (x_t^2 - x_1^2); \left[\Delta P_M = 5.942 \times 10^{-5} \frac{W_k^2}{\rho_{g,t}} (x_t^2 - x_1^2) \right] \quad (D17)$$

where

$$x_1 = x_t - \Delta x_1 \quad (D18)$$

and the vapor pressure at the end of the first 8 inches (20.3 cm) of condensing becomes

$$P_1 = P_t - (\Delta P_F - \Delta P_M) \quad (D19)$$

Step 4. - This step is a repetition of the procedure followed in step 3, in order to determine the pressure drop and fluid flow changes in the second 8-inch (20.3 cm) increment. The starting point for the second increment is the value of vapor pressure determined from equation (D19) when it is applied to the first increment. This step is repeated for successive increments until the value of quality becomes zero or negative, indicating that all condensation has taken place.

Last step. - When equations (D3) and (D4) are applied to the last condensing increment, the value obtained for Δx is most likely to be larger than the value of x at the beginning of the increment. To determine the length of the last increment to be included in the condensing length, a linear proportion of the 8 inches (20.3 cm) was taken:

$$L_{last} = 8 \left(\frac{x_{in, last}}{\Delta x_{last}} \right); \left[L_{last} = 20.3 \left(\frac{x_{in, last}}{\Delta x_{last}} \right) \right] \quad (D20)$$

The pressure drop in the last increment was neglected because of the low velocities involved. The resultant calculated condensing length was obtained by

$$\left. \begin{aligned} L_T &= N \left[8(\text{Number of increments} - 1) + L_{\text{last}} \right]; \\ \left[L_T &= N \left[20.3(\text{Number of increments} - 1) + L_{\text{last}} \right] \right] \end{aligned} \right\} \quad (\text{D21})$$

The pressure drop for the specified flow rate and inlet header temperature was

$$\Delta P = (P_i - P_{\text{last}}) \quad (\text{D22})$$

where P_{last} is the last calculated value from equation (D19).

APPENDIX E

MAXIMUM SYSTEMIC ERROR DUE TO RADIATOR TUBE SURFACE THERMOCOUPLE APPLICATION

The thermocouples mounted on the condensing radiator tube surface to obtain temperature profiles are subject to heat losses and therefore have a systemic error. The application of these thermocouples is as shown in figure 10(a) and described in the section INSTRUMENTATION. For use in this discussion, the thermocouple installation is shown schematically in figure 32. The following assumptions have been made in this analysis:

(1) The surface of the tube in the location of the thermocouple is isothermal, and the temperatures at the junction, point 1, and at the point where the sheath contacts the surface again, point 2, are the same.

(2) No heat is transferred by conduction along the thermocouple wire at point 3 because of symmetry and assumption (1). Therefore, the thermocouple wire can be considered as a pin fin of length a , losing heat strictly by radiation to the surroundings. The model used to calculate the heat losses for the thermocouple is that of a circular cross section fin of length a and diameter d dissipating heat by radiation to its environment and drawing all the heat from its base, that is, from the thermocouple junction. In this way, the temperature at the base of the fin T_{th} is lowered from its undisturbed value T , which is the temperature of the isothermal surface around the point of application. The actual reading of the thermocouple and the true temperature are represented by T_{th} and T , respectively. The heat loss from the thermocouple wire to the walls of the chamber is expressed by

$$Q_{th} = \sigma \epsilon_{th} F(\pi da) \eta (T_{th})^4 \quad (E1)$$

Equation (E1) neglects the chamber temperature as being too low to have any effect. The fin efficiency η can be obtained from reference 3. This fin efficiency is a function of a length parameter A defined as follows:

$$A \equiv a \sqrt{\frac{4\sigma \epsilon_{th} \times 10^9}{k_{th} d} \left(\frac{T_{th}}{1000} \right)^3} \quad (E2)$$

Equation (E2) was derived by the same method used in reference 3 for plate fins. The heat from the surrounding tube supplied to the sink formed by the thermocouple junction

can be expressed as

$$Q_{th} = 2dk_w(T - T_{th}) \quad (E3)$$

as suggested in reference 16. Combining equations (E1) and (E3) results in

$$T - T_{th} = (\sigma\epsilon_{th} F)\eta\left(\frac{\pi a}{2k_w}\right)(T_{th})^4 \quad (E4)$$

The numerical values applicable to the 0.010-inch (0.025 cm) Chromel-Alumel thermocouples used on the radiator tube surfaces are

Surface thermocouple total hemispherical emissivity (ref. 17), ϵ_{th}	0.75
Thermocouple radiating length, a, ft; m	0.0416; (0.01268)
Thermocouple diameter, d, ft; m	0.00083; 0.000233
Thermocouple thermal conductivity, k_{th} , Btu/(hr)(ft)($^{\circ}$ R); W/(m)($^{\circ}$ K)	16; 2.31
Wall thermal conductivity, k_w , Btu/(hr)(ft)($^{\circ}$ R); W/(m)($^{\circ}$ K)	10; (1.44)

Using a value of $F = 1$ will maximize the systemic error predicted by equation (E4). Thus, the entire surface of the thermocouple is assumed to be exposed exclusively to the tank walls, and does not see any part of the radiator. When the preceding numerical values are substituted into equations (E2) and (E4), the following equations particular to this thermocouple configuration are obtained:

$$A = 0.823\left(\frac{T_{th}}{1000}\right)^{3/2} \quad (E5)$$

$$T - T_{th} = 8.45 \times 10^{-4} \eta \left(\frac{T_{th}}{100}\right)^4 \quad (E6)$$

A curve of temperature corrections $T - T_{th}$ as a function of T_{th} (fig. 33) was obtained by substituting values of T_{th} ranging from 1000° to 2000° R (556° to 1111° K) in equations (E5) and (E6), and obtaining fin efficiency values from the η against A curve of reference 3.

REFERENCES

1. Krebs, Richard P. ; Haller, Henry C. ; and Auer, Bruce M. : Analysis and Design Procedures for a Flat, Direct-Condensing, Central Finned-Tube Radiator. NASA TN D-2474, 1964.
2. Stockman, Norbert O. ; Bittner, Edward C. ; and Sprague, Earl L. : Comparison of One- and Two-Dimensional Heat-Transfer Calculations in Central Fin-Tube Radiators. NASA TN D-3645, 1966.
3. Lieblein, Seymour: Analysis of Temperature Distribution and Radiant Heat Transfer Along a Rectangular Fin of Constant Thickness. NASA TN D-196, 1959.
4. Acker, Loren W. ; Sekas, Nick J. ; and Lieblein, Seymour: Description and Design of Liquid-Metal Radiator and Condenser Test Facility. NASA TM X-1396, 1967.
5. Liebert, Curt H. : Spectral Emittance of Aluminum Oxide and Zinc Oxide on Opaque Substrates. NASA TN D-3115, 1965.
6. Sparrow, E. M. ; and Minkowycz, W. J. : Heat-Transfer Characteristics of Several Radiator Finned-Tube Configurations. NASA TN D-1435, 1962.
7. Haller, Henry C. : Comparison of Heat-Rejection and Weight Characteristics of Several Radiator Fin-Tube Configurations. NASA TN D-2385, 1964.
8. Haller, Henry C. ; Wesling, Gordon C. ; and Lieblein, Seymour: Heat-Rejection and Weight Characteristics of Fin-Tube Space Radiators with Tapered Fins. NASA TN D-2168, 1964.
9. Fenn, David B. ; Acker, Loren W. ; and Coe, Harold H. : Steady-State Performance of a Seven-Tube NaK-Cooled Potassium Condenser. NASA TN D-4020, 1967.
10. Weatherford, W. D. , Jr. ; Tyler, John C. ; and Ku, P. M. : Properties of Inorganic Energy-Conversion and Heat-Transfer Fluids for Space Applications. (WADD TR 61-96), Southwest Research Inst. , Nov. 1961.
11. Coe, Harold H. : Summary of Thermophysical Properties of Potassium. NASA TN D-3120, 1965.
12. Lockhart, R. W. ; and Martinelli, R. C. : Proposed Correlation of Data for Isothermal Two-Phase, Two-Component Flow in Pipes. Chem. Eng. Progr. , vol. 45, no. 1, Jan. 1949, pp. 39-48.
13. Sawochka, S. G. : Thermal and Fluid Dynamic Performance of Potassium During Condensation Inside a Tube. AIAA Specialists Conference on Rankine Space Power Systems. Vol. 1, 1965, pp. 669-693.



14. Arnstein, H. L. ; and Kunz, H. R. : Experimental Evaluation of Hydrodynamic Losses in Manifolds. Vol. 1 of Experimental Investigation of Heat Rejection Problems in Nuclear Space Powerplants. Rep. No. PWA-2227, vol. 1 (NASA CR-55067), Pratt and Whitney Aircraft, 1963.
15. Goodykoontz, Jack H. ; and Brown, William F. : Local Heat-Transfer and Pressure Distributions for Freon-113 Condensing in Downward Flow in a Vertical Tube. NASA TN D-3952, 1967.
16. Chapman, Alan J. : Heat Transfer. Macmillan Co., 1960, p. 392.
17. Glawe, George E. ; Simmons, Frederick S. ; and Stickney, Truman M. : Radiation and Recovery Corrections and Time Constants of Several Chromel-Alumel Thermocouple Probes in High-Temperature, High-Velocity Gas Streams. NACA TN-3766, 1956.

TABLE I. - DATA FROM ALL-LIQUID RUNS

(a) U. S. Customary Units

Run	W_h , lb/hr	T_{h1} , °R	T_{h2} , °R	ΔT_h , °R	W_k , lb/hr	T_{k1} , °R	T_{k2} , °R	T_{k3} , °R	T_{k4} , °R	T_{k5} , °R	T_{k6A} , °R	T_{k6B} , °R	T_{k6C} , °R	T_{k6D} , °R	$T_{m,H}$, °R	T_{k61} , °R	T_{k62} , °R	T_{k63} , °R	T_{k64} , °R
L 1	21200	1437	1458	23.4	944	1003	1455	1528	1514	1509	1476	1469	1454	1427	1459	1483	1488	1465	1445
L 2	24000	1441	1457	18.8	850	983	1455	1543	1529	1522	1488	1477	1461	1434	1465	1488	1491	1470	1450
L 3	23900	1642	1652	10.3	394	1084	1645	1709	1672	1629	1564	1526	1498	1465	1513	1509	1502	1498	1478
L 4	23700	1641	1650	10.2	394	1080	1644	1688	1655	1615	1552	1514	1486	1454	1502	1499	1491	1488	1467
L 5	23600	1644	1651	7.9	373	1208	1645	1771	1724	1661	1592	1548	1518	1483	1536	1528	1521	1519	1497
L 6	23600	1643	1650	7.9	368	1210	1644	1774	1726	1661	1591	1548	1517	1482	1535	1527	1519	1518	1495
L 7	23800	1696	1703	7.9	377	1210	1696	1817	1771	1702	1625	1579	1547	1510	1565	1556	1549	1548	1526
L 8	23700	1696	1703	8.3	377	1210	1696	1819	1774	1703	1628	1581	1549	1512	1568	1558	1551	1550	1528
L 9	23700	1683	1704	23.4	918	1130	1699	1759	1739	1724	1673	1648	1628	1591	1635	1661	1660	1645	1616
L10	23600	1683	1703	21.4	900	1125	1699	1758	1739	1723	1672	1645	1625	1588	1633	1657	1657	1641	1612
L11	23500	1684	1703	19.3	805	1117	1699	1763	1741	1723	1670	1639	1617	1579	1626	1645	1643	1630	1604
L12	23400	1686	1702	16.7	695	1119	1697	1768	1744	1722	1665	1628	1603	1565	1615	1628	1623	1613	1587
L13	23600	1690	1703	14.2	580	1133	1697	1781	1752	1723	1658	1618	1590	1551	1604	1607	1599	1596	1570
L14	23500	1695	1705	10.8	449	1162	1699	1803	1766	1718	1643	1597	1564	1525	1582	1576	1569	1566	1543
L15	23500	1696	1703	8.2	350	1270	1694	1823	1776	1686	1609	1558	1525	1487	1545	1534	1526	1524	1502
L16	23600	1698	1704	7.1	234	1054	1695	1846	1802	1624	1542	1493	1460	1425	1480	1467	1460	1457	1437
L17	23800	1694	1702	9.7	402	1170	1695	1824	1786	1717	1638	1588	1554	1516	1574	1563	1557	1554	1532
L18	23400	1734	1744	10.0	399	1170	1737	1841	1801	1727	1646	1594	1561	1521	1581	1569	1563	1561	1536
L19	23600	1774	1782	10.0	401	1175	1775	1874	1833	1753	1670	1615	1580	1539	1601	1588	1580	1580	1558
L20	23500	1828	1836	10.4	397	1181	1829	1909	1864	1776	1691	1632	1595	1552	1618	1603	1596	1593	1571
L21	23200	1880	1889	10.8	397	1190	1882	1948	1901	1802	1716	1651	1614	1570	1638	1619	1613	1613	1586
L22	23000	1943	1955	13.3	397	1074	1948	1997	1944	1833	1745	1677	1637	1591	1663	1642	1636	1635	1609
L23	23700	1641	1657	18.7	691	1054	1652	1736	1715	1687	1633	1598	1571	1534	1584	1598	1592	1582	1554
L24	22600	1942	1959	19.6	608	1122	1952	1968	1931	1886	1805	1742	1706	1654	1727	1722	1714	1713	1681

Run	T_{t1} , °R	T_{t2} , °R	T_{t3} , °R	T_{t4} , °R	T_{t5} , °R	T_{t6} , °R	T_{t7} , °R	T_{t8} , °R	T_{t9} , °R	T_{k8} , °R	W_c , lb/hr	$T_{c,o}$, °R	ΔT_c , °R	$T_{w,o}$, °R	T_a , °R	$Q_{E,s}$, Btu/hr	$Q_{E,w}$, Btu/hr
L 1	1387	1388	1396	1401	1406	1413	1427	1429	1419	969	67000	639	2.9	631	567	17700	950
L 2	1390	1390	1398	1403	1409	1416	1430	1431	1420	946	67200	632	1.8	622	567	18100	950
L 3	1401	1403	1406	1406	1412	1419	1428	1426	1414	835	66800	626	0.9	616	563	11800	970
L 4	1393	1394	1397	1398	1403	1409	1418	1417	1404	832	67000	625	0.2	615	560	11800	970
L 5	1412	1413	1416	1416	1421	1429	1437	1437	1423	782	67000	624	0.2	614	559	17900	960
L 6	1411	1411	1414	1414	1420	1428	1435	1435	1420	777	67000	623	0.2	614	558	17900	970
L 7	1435	1437	1437	1441	1447	1453	1459	1459	1444	779	67000	624	0.2	614	558	18300	960
L 8	1437	1437	1439	1441	1446	1454	1461	1460	1445	780	67000	625	0.2	615	559	18400	960
L 9	1528	1530	1537	1545	1550	1561	1573	1577	1560	954	74800	585	6.1	581	555	18200	960
L10	1525	1527	1532	1541	1547	1558	1571	1573	1557	946	74200	576	5.7	571	553	18100	940
L11	1515	1517	1521	1528	1535	1544	1556	1561	1543	919	73700	571	4.5	566	548	18000	950
L12	1500	1501	1504	1510	1518	1527	1537	1540	1525	885	73500	569	4.6	563	546	17800	960
L13	1481	1483	1486	1490	1498	1506	1515	1515	1499	848	37400	567	6.2	561	548	18000	960
L14	1453	1454	1455	1459	1466	1473	1480	1480	1464	801	37400	566	5.5	560	548	17800	980
L15	1413	1413	1416	1411	1422	1431	1437	1437	1423	753	37400	563	4.7	558	553	17900	980
L16	1346	1349	1354	1319	1344	1363	1369	1368	1355	692	37500	558	4.0	554	554	18100	980
L17	1442	1443	1444	1421	1450	1462	1469	1468	1454	777	37400	562	6.3	557	554	18400	980
L18	1445	1446	1453	1427	1450	1467	1473	1473	1457	776	37300	561	6.5	556	551	17600	960
L19	1461	1463	1458	1437	1465	1482	1488	1486	1472	780	37300	561	6.5	556	551	18300	950
L20	1474	1474	1478	1446	1474	1495	1499	1499	1482	780	37300	561	6.6	556	552	18400	960
L21	1488	1489	1491	1456	1475	1509	1513	1511	1495	781	37300	561	6.6	556	550	18100	960
L22	1502	1503	1507	1504	1511	1523	1527	1526	1508	773	37500	563	6.6	557	551	18400	970
L23	1470	1472	1479	1480	1491	1500	1510	1512	1498	884	38000	574	7.2	566	556	18100	950
L24	1572	1576	1579	1548	1593	1599	1605	1605	1585	877	72700	621	1.6	610	561	18100	960

(b) SI Units

Run	W _h , kg/hr	T _{h1} , °K	T _{h2} , °K	ΔT _h , °K	W _k , kg/hr	T _{k1} , °K	T _{k2} , °K	T _{k3} , °K	T _{k4} , °K	T _{k5} , °K	T _{k6A} , °K	T _{k6B} , °K	T _{k6C} , °K	T _{k6D} , °K	T _{m,H} , °K	T _{k61} , °K	T _{k62} , °K	T _{k63} , °K	T _{k64} , °K
L 1	9640	798	810	13.0	428	557	808	849	841	838	820	816	808	793	811	824	827	814	803
L 2	10900	801	809	10.4	386	546	808	857	849	846	827	821	812	797	814	827	828	817	806
L 3	10870	912	918	5.7	179	607	914	949	929	905	869	848	832	814	841	838	834	832	821
L 4	10750	912	917	5.7	179	600	913	938	919	897	862	841	826	808	834	833	828	827	815
L 5	10710	913	917	4.4	169	671	914	984	958	923	884	860	843	824	853	849	845	844	832
L 6	10710	913	917	4.4	167	672	913	986	959	923	884	860	843	823	853	848	844	843	831
L 7	10790	942	946	4.4	171	672	942	1009	984	946	903	877	859	839	869	864	861	860	848
L 8	10750	942	946	4.6	171	672	942	1011	986	946	904	878	861	840	871	866	862	861	849
L 9	10770	935	947	13.0	416	628	944	977	966	958	929	916	904	884	908	923	922	914	898
L10	10700	935	946	11.9	408	625	944	977	966	957	929	914	903	882	907	921	921	912	896
L11	10670	936	946	10.7	365	621	944	979	967	957	928	911	898	877	903	914	913	906	891
L12	10630	937	946	9.3	315	622	943	982	969	957	925	904	891	869	897	904	902	896	882
L13	10690	939	946	7.9	263	629	943	989	973	957	921	899	883	862	891	893	888	887	872
L14	10640	942	947	6.0	204	646	944	1002	981	954	913	887	869	847	879	876	872	870	857
L15	10640	942	946	4.6	159	678	941	1013	987	937	894	866	847	826	858	852	848	847	834
L16	10690	943	947	3.9	106	586	942	1026	1001	902	857	829	811	792	822	815	811	809	798
L17	10790	941	946	5.4	182	650	942	1013	992	954	910	882	863	842	874	868	865	863	851
L18	10610	963	969	5.6	181	650	965	1023	1001	959	914	886	867	845	878	872	868	867	853
L19	10710	986	990	5.6	182	653	986	1041	1018	974	928	897	878	855	889	882	878	878	866
L20	10640	1016	1020	5.8	180	656	1016	1061	1036	987	939	907	886	862	899	891	887	885	873
L21	10530	1044	1049	6.0	180	661	1046	1082	1056	1001	953	917	897	872	910	899	896	896	881
L22	10420	1079	1086	7.4	180	597	1082	1109	1080	1018	969	932	909	884	924	912	909	908	894
L23	10730	912	921	10.4	313	586	918	964	953	937	907	888	873	852	880	888	884	879	863
L24	10240	1079	1088	10.9	276	623	1084	1093	1073	1048	1003	968	948	919	959	957	952	952	934

Run	T _{t1} , °K	T _{t2} , °K	T _{t3} , °K	T _{t4} , °K	T _{t5} , °K	T _{t6} , °K	T _{t7} , °K	T _{t8} , °K	T _{t9} , °K	T _{k8} , °K	W _c , kg/hr	T _{c,o} , °K	ΔT _c , °K	T _{w,o} , °K	T _a , °K	Q _{E,s} , W	Q _{E,w} , W
L 1	771	771	774	778	791	785	793	794	788	538	30390	355	1.6	351	315	5180	280
L 2	772	772	777	779	783	787	794	795	789	526	30470	351	1.0	346	315	5300	280
L 3	773	779	781	781	784	788	793	792	786	464	30320	348	0.5	342	313	3450	280
L 4	774	774	776	777	779	783	788	787	780	462	30400	347	0.1	342	311	3450	280
L 5	784	785	797	787	789	794	798	798	791	434	30370	347	0.1	341	311	5250	280
L 6	784	784	796	786	789	793	797	797	789	432	30370	346	0.1	341	310	5250	280
L 7	797	798	798	801	804	807	811	811	802	433	30390	347	0.1	341	310	5350	280
L 8	799	798	799	801	803	808	812	811	803	433	30400	347	0.1	342	311	5400	280
L 9	849	850	854	858	861	867	874	876	867	530	33950	325	3.4	323	308	5330	280
L10	847	848	851	856	859	866	873	874	865	526	33660	320	3.2	317	307	5300	270
L11	842	843	845	849	853	858	864	867	857	511	33440	317	2.5	314	304	5280	280
L12	833	834	836	839	843	848	854	856	847	492	33320	316	2.6	313	303	5220	280
L13	823	824	826	828	832	837	842	842	833	471	16940	315	3.4	312	304	5280	280
L14	807	808	808	811	814	818	822	822	813	445	16970	314	3.1	311	304	5220	290
L15	795	795	797	784	790	795	798	798	791	418	16940	313	2.6	310	307	5250	290
L16	748	749	752	733	747	757	761	760	753	384	17000	310	2.2	308	308	5300	290
L17	801	802	802	789	806	812	816	816	808	432	16970	312	3.5	309	308	5400	290
L18	803	803	807	793	806	815	818	818	809	431	16930	312	3.6	309	306	5150	280
L19	812	813	816	798	814	823	827	826	818	433	16930	312	3.6	309	306	5350	280
L20	819	819	821	803	819	831	833	833	823	433	16930	312	3.7	309	307	5390	280
L21	827	827	828	809	819	838	841	839	831	434	16930	312	3.7	309	306	5300	280
L22	834	835	837	836	839	846	848	838	829	429	16990	313	3.7	309	306	5380	290
L23	817	818	822	822	828	833	839	840	832	491	17230	319	4.0	314	309	5300	280
L24	873	876	877	860	885	888	892	892	881	487	32980	345	0.9	339	312	5300	280

TABLE II. - HEATING AND COOLING LOOP DATA FOR TWO-PHASE RUNS

(a) U. S. Customary Units

Run	O-R	W _h '	T _{h1} '	T _{h2} '	ΔT _h '	W _c '	T _{c,o} '	ΔT _c '	T _{w,i} '	T _{w,o} '	T _a '	Q _{E, s} '	Q _{E, w} '
		lb/hr	°R	°R	°R	lb/hr	°R	°R	°R	°R	°R	Btu/hr	Btu/hr
1	354	22600	1913	1957	48.0	79000	589	7.0	615	581	555	3600	960
2	352	22600	1914	1958	47.5	79800	592	7.3	619	584	559	17800	950
3	350	22700	1902	1957	56.8	79400	602	8.3	633	593	551	17800	940
4	355	22400	1896	1959	63.9	79400	600	8.6	632	591	560	3600	950
5	351	22600	1900	1957	59.5	79400	603	8.9	634	594	560	17800	950
6	417	21700	1912	1975	65.4	79300	597	9.0	632	587	546	8400	930
7	418	21900	1909	1976	67.3	79300	597	9.0	633	587	546	8400	940
8	357	22600	1886	1955	71.5	79500	608	9.8	643	599	561	3600	940
9	416	21900	1903	1979	77.7	79500	605	10.1	643	593	547	8400	910
10	414	22000	1900	1974	76.4	79700	610	10.7	648	600	551	8400	900
11	415	22000	1895	1975	81.3	79500	609	10.7	647	599	550	8400	900
12	365	22300	1953	1992	41.4	78500	580	5.8	601	572	548	10200	940
13	364	22300	1943	1995	40.7	79100	587	7.0	615	578	551	10200	940
14	363	22200	1938	1991	55.7	79300	595	8.9	622	585	554	10000	940
15	361	22400	1936	1994	59.2	79300	599	8.3	627	590	558	10100	940
16	362	22300	1935	1994	58.9	79300	598	8.2	626	588	555	10100	940
17	360	22300	1928	1991	64.9	79400	605	9.0	635	596	557	10100	960
18	413	21900	1989	2063	71.6	79500	608	10.4	642	599	558	18100	940
19	417	21900	1974	2061	85.2	79800	615	11.5	655	605	559	17900	930
20	409	21700	1959	2062	101.7	80000	627	13.1	669	618	558	17500	940
21	407	21900	1859	1964	107.5	80100	632	14.1	675	623	556	17400	920
22	406	21900	1859	1967	111.5	80100	635	14.5	678	627	558	17400	920
23	405	21900	1857	1966	111.1	80100	636	14.5	679	628	559	17400	920
24	421	22300	2000	1937	63.4	79500	600	8.2	630	590	559	8400	950
25	422	22200	2018	1949	69.1	79500	604	9.0	635	595	559	8400	930
26	423	22000	2044	1975	72.8	79600	606	9.6	637	597	558	8300	940
27	439	22800	1932	1859	76.0	79700	613	9.9	646	603	555	8400	910
28	430	22600	1960	1886	76.6	79600	607	10.3	642	596	554	8400	920
29	424	22600	2058	1984	74.6	79700	609	9.9	642	600	559	8600	920
30	440	22600	1952	1872	82.2	79800	614	10.3	650	604	553	8300	910
31	429	22500	1979	1900	81.2	79700	611	10.5	647	602	556	8400	910
32	438	22700	1958	1880	80.4	79800	616	10.8	651	606	557	8400	910
33	441	22600	1973	1891	86.7	79800	616	11.1	654	607	552	8400	910
34	437	22600	1979	1897	84.8	79900	618	11.1	656	609	558	8400	910
35	428	22600	2000	1914	83.5	79800	613	10.9	650	604	557	8500	920
36	442	22600	1972	1884	87.5	79800	618	11.1	655	608	551	8400	910
37	427	22300	2020	1931	87.8	79900	616	11.3	654	607	558	8400	910
38	436	22500	1998	1912	88.7	79900	619	11.4	658	610	558	8400	920
39	431	22100	2080	1992	90.4	79800	616	11.6	655	609	554	8300	930
40	443	22500	1991	1901	91.6	79900	619	11.7	659	610	551	8400	910
41	426	22300	2040	1949	89.9	79900	619	11.5	657	610	559	8400	910
42	425	22500	2058	1968	90.7	80000	620	11.7	658	611	558	8500	910
43	435	22400	2014	1923	93.4	80000	620	11.8	659	612	558	8400	930
44	434	22200	2038	1942	96.0	80000	621	12.1	661	612	556	8300	920
45	444	22400	2019	1921	98.3	80000	623	12.1	662	613	549	8400	900
46	433	22300	2056	1959	96.0	79900	621	12.4	661	612	555	8500	920
47	432	22300	2079	1981	98.5	80000	621	12.3	662	612	555	8500	920
48	446	22200	2075	1967	106.2	80000	627	12.2	670	616	549	8400	900
49	445	22300	2050	1947	103.8	80100	625	12.7	667	628	550	8400	900
50	374	22400	1990	2049	60.2	79500	600	8.7	630	590	555	18000	930
51	375	22100	1995	2067	70.4	79700	611	10.1	642	602	561	17500	930
52	376	22200	2002	2079	75.8	79800	614	10.6	648	606	563	17800	920
53	395	21900	1974	2050	79.6	79800	616	10.9	651	606	556	17800	950
54	396	21800	2009	2092	81.9	79900	614	10.9	650	605	554	17800	950
55	398	21700	2009	2091	81.0	79800	616	10.9	651	606	553	17800	950
56	397	21800	2006	2092	83.2	79900	617	11.2	653	607	554	17800	950
57	387	22200	1930	2019	92.5	79900	623	12.2	661	613	557	17700	930
58	386	22200	1937	2027	92.6	80000	623	12.2	662	613	555	17800	940
59	385	22300	1978	2020	91.0	80000	622	12.2	661	613	555	18100	940
60	394	21800	2016	2115	97.4	80000	627	12.7	666	618	558	17700	940
61	389	21900	1971	2018	100.7	80000	632	13.4	672	624	565	17400	930
62	388	22000	1911	2019	110.2	80200	638	14.5	680	630	563	17600	930
63	384	22000	1914	2018	108.3	80300	635	14.1	678	627	557	17800	930
64	391	22000	1928	2037	110.3	80200	638	14.3	680	621	565	17700	930
65	383	22100	1917	2028	111.1	80200	638	14.3	681	629	557	17800	930
66	377	21900	1918	2031	111.8	80100	636	14.2	680	628	563	17400	920
67	382	22000	1928	2038	112.5	80200	638	14.6	683	629	558	17900	930
68	379	22000	1916	2024	110.5	80100	641	14.7	685	634	563	17700	920
69	380	22100	1924	2033	107.9	80200	640	14.6	685	632	560	17800	920
70	378	22000	1914	2021	111.6	80000	641	15.0	685	633	563	17800	910
71	381	22200	1929	2036	110.5	80200	640	15.0	684	631	558	17400	920
72	399	21600	2012	2090	75.8	79800	611	10.0	645	601	553	9900	950
73	400	21600	1997	2092	91.6	79800	617	14.1	656	605	553	17200	950
74	401	21700	2004	2091	84.4	70800	658	10.9	690	648	565	17800	940
75	402	21800	1994	2088	90.9	70800	662	12.5	697	652	567	18100	940
76	403	21800	1982	2086	101.0	70700	666	13.1	703	656	566	17800	910
77	404	21700	1918	2028	111.0	80100	636	14.3	678	628	562	17400	900

TABLE II - Concluded. HEATING AND COOLING LOOP DATA FOR TWO-PHASE RUNS

(b) SI Units

Run	O-R	W_h kg/hr	T_{h1} °K	T_{h2} °K	ΔT_h °K	W_c kg/hr	$T_{c,o}$ °K	ΔT_c °K	$T_{w,i}$ °K	$T_{w,o}$ °K	T_a °K	$Q_{E,s}$ W	$Q_{E,w}$ W
1	354	10240	1063	1087	26.7	35820	377	3.9	342	323	308	1060	280
2	357	10260	1063	1088	26.4	36180	329	4.1	344	324	311	5220	280
3	350	10310	1057	1087	31.6	36030	334	4.6	352	329	306	5220	280
4	355	10170	1053	1088	35.5	36000	333	4.8	351	328	311	1040	280
5	351	10250	1056	1087	33.1	36030	335	4.9	352	330	311	5220	280
6	417	9860	1062	1097	36.3	35970	332	5.0	351	326	303	2450	270
7	418	9940	1061	1098	37.4	35960	332	5.0	352	326	303	2450	280
8	357	10230	1048	1086	39.7	36060	338	5.4	357	333	312	1040	280
9	416	9940	1057	1099	43.2	36060	336	5.6	357	329	304	2450	270
10	414	10000	1056	1097	42.4	36140	339	5.9	360	333	306	2460	260
11	415	9970	1053	1097	45.2	36080	338	5.9	359	333	306	2450	260
12	365	10110	1085	1107	23.0	35610	322	3.2	334	318	304	2980	270
13	364	10130	1079	1108	27.6	35900	326	3.9	342	321	306	2980	280
14	363	10060	1077	1106	30.9	35950	331	4.9	346	325	308	2930	280
15	361	10160	1076	1108	32.9	35980	333	4.6	348	328	310	2950	280
16	367	10090	1075	1108	32.7	35970	332	4.6	348	327	308	2950	280
17	360	10110	1071	1106	36.1	36030	336	5.0	353	331	309	2950	280
18	413	9920	1105	1146	39.8	36060	338	5.8	357	333	310	5300	270
19	412	9920	1097	1145	47.3	36210	342	6.4	364	336	311	5250	270
20	409	9850	1088	1146	56.5	36310	348	7.3	372	343	310	5120	280
21	407	9930	1033	1091	59.7	36340	351	7.8	375	346	309	5100	270
22	406	9920	1033	1093	61.9	36340	353	8.1	377	348	310	5100	270
23	405	9920	1032	1092	61.7	36340	353	8.1	377	349	311	5100	270
24	421	10130	1111	1076	35.2	36040	333	4.6	350	328	311	2460	280
25	422	10050	1121	1083	38.4	36070	336	5.0	353	331	311	2450	270
26	423	9960	1136	1097	40.4	36090	337	5.3	354	332	310	2430	270
27	439	10340	1073	1033	42.2	36150	341	5.5	359	335	308	2450	270
28	430	10250	1089	1048	47.6	36120	337	5.7	357	331	308	2450	270
29	424	10230	1143	1102	41.4	36160	338	5.5	357	333	311	2520	270
30	440	10260	1084	1040	45.7	36190	341	5.7	361	336	307	2420	270
31	429	10230	1099	1056	45.1	36150	339	5.8	359	334	309	2450	270
32	438	10310	1088	1044	44.7	36220	342	6.0	362	337	309	2470	270
33	441	10240	1096	1051	48.2	36220	342	6.2	363	337	307	2450	270
34	437	10250	1099	1054	47.1	36240	343	6.2	364	338	310	2450	270
35	428	10230	1111	1063	46.4	36190	341	6.1	361	336	309	2480	270
36	442	10240	1096	1047	48.6	36220	343	6.2	364	338	306	2450	270
37	427	10120	1122	1073	48.8	36240	342	6.3	363	337	310	2460	270
38	436	10200	1110	1062	49.3	36240	344	6.3	366	339	310	2470	270
39	431	10020	1156	1107	50.2	36220	342	6.4	364	338	308	2420	270
40	443	10190	1106	1056	50.9	36260	344	6.5	366	339	306	2460	270
41	426	10120	1133	1083	49.9	36240	344	6.4	365	339	311	2450	270
42	425	10220	1143	1093	50.1	36270	344	6.5	366	339	310	2500	270
43	435	10150	1119	1068	51.9	36270	344	6.6	366	340	310	2450	270
44	434	10060	1132	1079	53.3	36280	345	6.7	367	340	309	2440	270
45	444	10160	1122	1067	54.6	36280	346	6.7	368	341	305	2450	260
46	433	10110	1142	1088	53.1	36260	345	6.9	367	340	308	2480	270
47	432	10100	1155	1101	54.7	36310	345	6.8	368	340	308	2490	270
48	446	10070	1153	1093	59.0	36310	348	6.8	372	342	305	2470	260
49	445	10100	1139	1082	57.7	36340	347	7.1	371	349	306	2460	260
50	374	10140	1106	1138	33.4	36060	333	4.8	350	328	308	5280	270
51	375	10020	1108	1148	39.1	36130	339	5.6	357	334	312	5130	270
52	376	10050	1112	1155	42.1	36180	341	5.9	360	337	313	5200	270
53	395	9930	1097	1139	44.2	36200	342	6.1	362	337	309	5200	280
54	396	9880	1116	1162	45.5	36230	341	6.1	361	336	308	5200	280
55	398	9860	1116	1162	45.0	36220	342	6.1	362	337	307	5200	280
56	397	9870	1114	1162	46.2	36250	343	6.2	363	337	308	5200	280
57	387	10050	1072	1122	51.4	36250	346	6.8	367	341	309	5190	270
58	386	10080	1076	1126	51.4	36270	346	6.8	368	341	308	5200	280
59	385	10110	1071	1122	50.6	36290	346	6.8	367	341	308	5300	280
60	394	9910	1120	1175	54.1	36310	348	7.1	370	343	310	5180	280
61	389	9950	1067	1121	55.9	36280	351	7.4	373	347	314	5100	270
62	388	9960	1062	1122	61.2	36360	354	8.1	378	350	313	5150	270
63	384	10000	1063	1121	60.2	36400	353	7.8	377	348	309	5200	270
64	391	10000	1071	1132	61.3	36360	354	7.9	378	345	314	5180	270
65	383	10030	1065	1127	61.7	36360	354	7.9	378	349	309	5200	270
66	377	9940	1066	1128	62.1	36320	353	7.9	378	349	313	5100	270
67	382	10000	1071	1132	62.5	36360	354	8.1	379	349	310	5250	270
68	379	10000	1064	1124	61.4	36330	356	8.2	381	352	313	5180	270
69	380	10000	1069	1129	59.9	36380	356	8.1	381	351	311	5200	270
70	378	10000	1063	1123	62.0	36290	356	8.3	381	352	313	5200	270
71	381	10050	1072	1131	61.4	36360	356	8.3	380	351	310	5100	270
72	399	9800	1118	1161	42.1	36170	339	5.6	358	334	307	2900	280
73	400	9800	1109	1162	50.9	36210	343	7.8	364	336	307	5050	280
74	401	9830	1113	1162	46.9	32110	366	6.1	383	360	314	5200	280
75	402	9900	1108	1160	50.5	32100	368	6.9	387	362	315	5300	280
76	403	9900	1101	1159	56.1	32090	370	7.3	391	364	314	5200	270
77	404	9860	1066	1127	61.7	36340	353	7.9	377	349	312	5100	260

TABLE III. - POTASSIUM LOOP DATA FOR TWO-PHASE RUNS

(a) U. S. Customary Units

Run	O-R	T _{k1'} °R	T _{k2'} °R	T _{k3'} °R	T _{k4'} °R	T _{k41'} °R	T _{k5'} °R	T _{m,H'} °R	T _{k61'} °R	T _{k62'} °R	T _{k63'} °R	T _{k64'} °R	T _{k70'} °R	T _{k8'} °R	W _{k'} lb/hr	P _{b,i'} psia	P _{b,o'} psia	P _{i'} psia	P _{o'} psia	ΔP _{e'} psi
1	354	873	1709	1705	1702	1710	1706	1671	1710	1708	1709	1706	756	770	231	11.8	6.7	6.6	6.4	-0.10
2	352	908	1693	1794	1752	1805	1709	1651	1739	1728	1723	1713	772	786	228	10.9	6.2	5.8	5.6	-0.16
3	350	981	1712	1780	1738	1790	1717	1666	1743	1735	1731	1724	857	862	277	9.4	7.0	6.7	6.2	-0.25
4	355	913	1724	1719	1714	1725	1715	1680	1714	1715	1716	1716	868	871	304	10.9	7.0	6.8	6.5	0.16
5	351	945	1719	1800	1763	1805	1730	1673	1757	1748	1744	1735	870	874	289	16.6	7.0	6.6	6.2	-0.11
6	417	1016	1706	1695	1691	1709	1691	1657	1690	1690	1692	1692	885	898	311	9.8	6.5	5.9	5.2	0.43
7	418	1032	1707	1691	1686	1693	1684	1651	1684	1684	1685	1684	893	904	322	9.8	6.5	5.9	4.7	0.46
8	357	984	1721	1709	1704	1710	1706	1670	1704	1703	1706	1706	960	957	351	9.8	7.0	6.6	5.5	0.50
9	416	1117	1717	1695	1686	1709	1686	1653	1685	1685	1687	1688	1016	1018	377	10.9	6.7	5.9	4.1	0.87
10	414	1205	1707	1693	1682	1693	1678	1646	1678	1679	1681	1680	1128	1120	374	10.9	6.7	5.9	3.1	1.02
11	415	1210	1717	1704	1693	1710	1689	1656	1687	1694	1693	1692	1154	1146	396	11.4	6.8	6.2	3.3	1.02
12	365	848	1828	1804	1798	1828	1802	1760	1814	1810	1809	1805	692	722	187	12.3	11.2	11.2	11.2	-0.10
13	364	856	1807	1809	1803	1828	1806	1765	1818	1816	1814	1810	744	766	233	13.0	11.4	11.6	11.5	-0.02
14	363	857	1824	1822	1820	1828	1823	1781	1825	1825	1825	1824	776	794	268	13.8	12.4	12.7	12.6	0.03
15	361	892	1823	1821	1819	1818	1822	1780	1827	1821	1821	1821	814	828	314	13.4	12.3	12.5	12.4	0.08
16	362	877	1816	1812	1811	1808	1814	1777	1812	1812	1812	1813	800	817	291	13.2	11.9	11.9	12.0	0.11
17	360	913	1810	1807	1805	1805	1808	1766	1807	1806	1806	1806	846	857	336	15.0	11.5	11.7	11.5	0.19
18	413	995	1809	1806	1803	1813	1805	1763	1804	1803	1805	1805	878	890	364	13.8	11.4	11.5	11.1	0.27
19	412	1024	1821	1819	1813	1828	1814	1771	1813	1815	1813	1814	943	951	414	15.3	12.1	11.8	11.3	0.38
20	409	1139	1822	1827	1810	1836	1808	1767	1813	1819	1819	1811	1106	1103	496	15.6	12.3	11.8	10.2	0.70
21	407	1178	1826	1815	1811	1808	1810	1769	1810	1809	1810	1811	1188	1178	554	15.6	12.6	11.8	9.8	0.83
22	406	1246	1830	1817	1812	1808	1811	1770	1811	1810	1812	1811	1284	1267	609	15.5	12.5	11.8	9.3	0.95
23	405	1249	1828	1816	1811	1808	1810	1769	1811	1810	1812	1811	1273	1256	609	15.5	12.6	11.8	9.2	0.98
24	421	957	1819	1815	1813	1808	1815	1773	1815	1815	1815	1816	839	868	405	13.7	12.1	12.0	11.3	0.0
25	422	965	1819	1816	1813	1808	1816	1773	1815	1815	1815	1816	858	882	404	13.9	12.1	12.0	11.5	0.05
26	423	970	1819	1816	1814	1808	1816	1774	1815	1815	1815	1816	869	891	404	14.4	12.1	12.2	11.9	0.11
27	439	1037	1816	1810	1807	1808	1809	1766	1808	1807	1807	1808	960	983	575	14.7	11.8	11.7	10.7	0.19
28	430	1019	1816	1810	1807	1804	1809	1766	1808	1806	1808	1809	931	952	490	16.1	11.8	11.6	10.7	0.21
29	424	983	1822	1817	1815	1812	1817	1774	1816	1816	1817	1818	886	907	411	14.6	12.4	12.3	11.7	0.16
30	440	1048	1820	1811	1808	1810	1808	1767	1808	1807	1808	1808	981	1000	576	13.3	12.0	11.8	10.9	0.25
31	429	1034	1816	1809	1806	1804	1807	1765	1807	1805	1807	1807	948	967	483	15.8	12.1	11.6	11.0	0.27
32	438	1052	1817	1810	1806	1808	1807	1765	1806	1805	1807	1807	965	985	507	14.9	12.1	11.6	10.8	0.25
33	441	1065	1826	1818	1814	1810	1814	1773	1814	1814	1814	1815	1008	1024	584	15.6	12.4	12.1	10.9	0.41
34	437	1063	1820	1811	1812	1810	1808	1767	1808	1807	1808	1808	986	1002	523	14.9	11.8	11.7	10.7	0.33
35	428	1041	1818	1819	1806	1804	1807	1765	1806	1806	1807	1807	960	977	482	16.1	12.3	11.7	10.7	0.33
36	442	1074	1825	1815	1812	1810	1812	1770	1811	1810	1812	1811	1014	1030	577	15.5	12.4	11.7	10.4	0.40
37	427	1053	1823	1815	1811	1808	1813	1770	1811	1811	1813	1812	978	993	490	15.5	12.3	11.6	10.8	0.43
38	436	1073	1821	1812	1809	1810	1811	1769	1810	1810	1811	1811	1003	1015	522	14.6	12.1	11.8	10.6	0.43
39	431	1065	1821	1814	1811	1800	1811	1769	1810	1810	1812	1812	998	1010	481	15.6	12.1	11.6	10.7	0.65
40	443	1091	1826	1816	1812	1810	1812	1770	1811	1811	1811	1812	1040	1051	576	16.6	12.7	11.9	10.6	0.51
41	426	1062	1821	1814	1811	1808	1812	1770	1811	1812	1812	1812	990	1001	481	15.6	12.4	11.6	10.7	0.21
42	425	1067	1826	1820	1817	1810	1818	1775	1816	1816	1818	1817	998	1010	493	15.6	12.4	12.2	11.0	0.21
43	435	1087	1822	1813	1809	1808	1811	1769	1810	1810	1810	1811	1015	1025	515	13.3	11.8	11.7	10.8	0.43
44	434	1096	1824	1814	1812	1804	1813	1771	1812	1811	1812	1813	1034	1042	521	16.4	12.3	11.8	10.3	0.52
45	444	1113	1820	1810	1806	1808	1807	1765	1805	1805	1806	1806	1072	1077	571	16.8	12.4	11.7	10.0	0.60
46	433	1108	1821	1812	1809	1804	1810	1768	1808	1808	1810	1811	1058	1063	521	16.1	12.1	11.7	10.2	0.52
47	432	1103	1818	1809	1806	1804	1806	1765	1805	1805	1806	1807	1058	1062	521	16.1	12.0	11.7	10.0	0.65
48	446	1164	1830	1820	1815	1810	1815	1774	1816	1814	1816	1816	1142	1139	568	17.5	12.4	12.2	10.1	0.75
49	445	1142	1825	1814	1809	1810	1810	1768	1808	1809	1810	1810	1116	1116	564	16.1	12.4	11.8	9.7	0.67
50	374	909	1874	1871	1870	1870	1873	1827	1874	1874	1873	1873	857	873	400	16.8	16.0	16.2	16.3	0.06
51	375	934	1876	1873	1871	1870	1875	1828	1874	1874	1874	1874	892	903	422	17.5	16.8	16.7	16.8	0.10
52	376	941	1876	1873	1875	1870	1879	1832	1877	1877	1878	1878	908	914	424	18.2	17.3	16.7	16.5	0.17
53	395	995	1897	1893	1894	1890	1899	1831	1895	1897	1896	1883	926	941	473	18.6	17.4	17.4	17.1	0.06
54	396	962	1888	1886	1884	1880	1888	1840	1887	1887	1887	1887	894	908	435	19.4	17.8	17.7	17.0	0.06
55	398	961	1886	1882	1881	1880	1884	1837	1884	1883	1884	1884	900	913	421	19.4	17.2	17.4	17.0	0.06
56	397	973	1887	1884	1883	1880	1886	1838	1884	1885	1885	1885	918	930	437	18.9	17.3	17.5	17.1	0.10
57	387	1044	1896	1886	1886	1875	1886	1837	1885	1885	1885	1884	1006	1019	574	20.6	17.8	17.4	16.9	0.27
58	386	1044	1896	1888	1885	1870	1885	1839	1885	1886	1886	1883	1010	1020	551	20.7	18.4	17.1	16.5	0.30
59	385	1040	1889	1883	1881	1870	1882	1836	1882	1883	1883	1883	999	1012	551	21.2	16.9	17.1	16.5	0.30
60	394	1037	1885	1885	1879	1880	1881	1835	1880	1881	1881	1882	998	1004	494	20.0	17.8	17.2	16.3	0.25
61	389	1070	1893	1887	1885	1880	1887	1840	1886	1886	1886	1886	1042	1049	568	20.0	18.3	17.6	17.2	0.27
62	388	1138	1897	1888	1887	1880	1887	1840	1887	1889	1887	1888	1128	1130	661	21.0	17.1	17.7	16.6	0.48
63	384	1109	1892	1885	1884	1880	1886	1839	1885	1886	1886	1886	1094	1092	547	20.6	17.8	17.4	16.5	0.48
64	391	1112	1886	1878	1874	1880	187													

TABLE III - Concluded. POTASSIUM LOOP DATA FOR TWO-PHASE RUNS

(b) SI Units

Run	O-R	T _{k1'} °K	T _{k2'} °K	T _{k3'} °K	T _{k4'} °K	T _{k41'} °K	T _{k5'} °K	T _{m,H'} °K	T _{k61'} °K	T _{k62'} °K	T _{k63'} °K	T _{k64'} °K	T _{k70'} °K	T _{k8'} °K	W _{k'} kg/hr	P _{b,i'} kN/m ²	P _{b,o'} kN/m ²	P _{i'} kN/m ²	P _{o'} kN/m ²	ΔP _{e'} kN/m ²
1	354	485	949	947	946	950	948	928	950	949	949	948	420	428	105	81.4	46.2	45.5	44.4	-0.69
2	352	504	941	997	973	1003	949	917	966	960	957	952	429	437	103	75.2	42.7	40.0	38.7	-1.10
3	350	545	951	989	966	994	954	926	968	964	967	958	476	479	126	64.8	48.3	46.2	43.0	-1.72
4	355	507	958	955	952	958	953	933	952	953	953	953	482	484	138	75.2	48.3	46.9	44.7	1.10
5	351	525	955	1000	979	1003	961	929	976	971	969	964	483	486	131	114.5	48.3	45.5	42.7	-0.76
6	417	564	948	942	939	949	939	921	939	939	940	940	492	499	141	67.6	44.8	40.7	36.1	2.96
7	418	573	946	939	937	941	936	917	936	936	936	936	496	502	146	67.6	44.8	40.7	32.6	3.17
8	357	547	956	949	947	950	948	928	947	946	948	948	533	532	159	67.6	48.3	45.5	38.1	3.45
9	416	618	951	942	937	949	937	918	936	936	937	938	564	566	171	75.2	46.2	40.7	28.1	6.00
10	414	669	948	941	934	941	932	914	932	933	934	933	627	622	170	75.2	46.2	40.7	21.1	7.03
11	415	672	954	947	941	950	938	920	937	941	941	940	641	637	180	78.6	46.9	42.7	22.8	7.03
12	365	471	1016	1002	999	1016	1001	978	1008	1006	1005	1003	384	401	85	84.8	77.2	77.2	77.2	-0.69
13	364	476	1004	1005	1002	1016	1003	981	1010	1009	1008	1006	413	426	106	89.6	78.6	80.0	78.9	-0.14
14	363	476	1013	1012	1011	1016	1013	989	1014	1014	1014	1013	441	441	122	95.1	85.5	87.6	87.0	0.21
15	361	496	1013	1012	1011	1010	1017	989	1012	1012	1012	1012	452	460	142	92.4	84.8	86.2	85.3	0.55
16	362	487	1009	1007	1006	1004	1008	984	1007	1007	1007	1007	444	454	132	91.0	82.0	82.0	82.7	0.76
17	360	507	1006	1004	1003	1003	1004	981	1004	1003	1003	1004	470	476	152	103.4	79.3	80.7	79.3	1.31
18	413	553	1005	1003	1002	1007	1003	979	1002	1002	1003	1003	488	494	165	95.1	78.6	79.3	76.4	1.86
19	412	569	1012	1011	1007	1016	1008	984	1007	1008	1007	1008	524	528	188	105.5	83.4	81.4	77.8	2.62
20	409	633	1012	1015	1006	1020	1004	987	1007	1011	1011	1006	614	613	225	107.6	84.8	81.4	70.3	4.83
21	407	654	1014	1008	1006	1004	1006	983	1006	1005	1006	1006	660	654	251	107.6	86.9	81.4	67.4	5.72
22	406	692	1017	1009	1007	1004	1006	983	1006	1006	1007	1006	713	704	276	106.9	86.2	81.4	64.0	6.55
23	495	694	1016	1009	1006	1004	1006	983	1006	1006	1007	1006	707	698	276	106.9	86.9	81.4	63.7	6.76
24	421	532	1011	1008	1007	1004	1008	985	1008	1008	1008	1009	466	482	184	94.5	83.4	82.7	78.1	0.
25	422	536	1011	1009	1007	1004	1009	985	1008	1008	1008	1009	477	490	183	95.8	83.4	82.7	79.3	0.34
26	423	539	1011	1009	1008	1004	1009	986	1008	1008	1008	1009	483	495	183	99.3	83.4	84.1	81.8	0.76
27	439	576	1009	1006	1004	1004	1005	981	1004	1004	1004	1004	533	546	261	101.4	81.4	80.7	74.0	1.31
28	430	566	1009	1006	1004	1007	1005	981	1004	1003	1004	1005	517	529	222	111.0	81.4	80.0	74.0	1.45
29	424	546	1017	1009	1008	1007	1009	986	1009	1009	1009	1010	492	504	186	100.7	85.5	84.8	80.7	1.10
30	440	582	1011	1006	1004	1006	1004	982	1004	1004	1004	1004	545	556	261	91.7	82.7	81.4	74.9	1.72
31	429	574	1009	1005	1003	1007	1004	981	1004	1003	1004	1004	527	537	219	108.9	83.4	80.0	75.8	1.86
32	438	584	1009	1006	1003	1004	1004	981	1003	1003	1004	1004	536	547	240	102.7	83.4	80.0	74.4	1.72
33	441	592	1014	1010	1008	1006	1008	985	1008	1008	1008	1008	560	569	265	107.6	85.5	83.4	75.2	2.83
34	437	591	1011	1006	1007	1006	1004	982	1004	1004	1004	1004	548	557	237	102.7	81.4	80.7	73.5	2.28
35	428	578	1010	1011	1003	1002	1004	981	1003	1003	1004	1004	533	543	219	111.0	84.8	80.7	73.8	2.28
36	442	597	1014	1008	1007	1006	1007	983	1006	1006	1007	1006	563	572	262	106.9	85.5	80.7	71.5	2.76
37	427	585	1013	1008	1006	1004	1007	983	1006	1006	1007	1007	543	552	222	106.9	84.8	80.0	74.7	2.96
38	436	596	1012	1007	1005	1006	1006	983	1006	1006	1006	1006	557	564	237	100.7	83.4	81.4	73.2	2.96
39	431	592	1012	1008	1006	1000	1006	983	1006	1006	1007	1007	554	561	218	107.6	83.4	80.0	73.8	4.48
40	443	606	1014	1009	1007	1006	1007	983	1006	1006	1006	1007	578	584	261	114.5	87.6	82.0	72.9	3.52
41	426	590	1012	1008	1006	1004	1007	983	1006	1007	1007	1007	550	556	218	107.6	85.5	80.0	73.5	1.45
42	425	593	1014	1011	1009	1006	1010	986	1009	1009	1010	1009	554	561	224	107.6	85.5	84.1	76.1	1.45
43	435	601	1012	1007	1005	1004	1006	983	1006	1006	1006	1006	564	569	234	91.7	81.4	80.7	74.7	2.96
44	434	609	1013	1008	1007	1002	1007	984	1007	1006	1007	1007	574	579	236	113.1	84.8	81.4	71.2	3.59
45	444	618	1011	1006	1003	1004	1004	981	1003	1003	1003	1003	596	598	259	115.8	85.5	80.7	68.9	4.14
46	433	616	1012	1007	1005	1002	1006	982	1004	1004	1006	1006	588	591	236	111.0	83.4	80.7	70.6	3.59
47	432	613	1010	1005	1003	1002	1003	981	1003	1003	1003	1004	588	593	236	111.0	82.7	80.7	68.7	4.48
48	446	647	1017	1011	1008	1006	1008	986	1009	1008	1009	1009	634	633	258	120.7	85.5	84.1	69.8	5.17
49	445	634	1014	1008	1005	1006	1006	982	1004	1005	1006	1006	620	620	256	111.0	85.5	81.4	66.9	4.62
50	374	505	1041	1039	1039	1039	1041	1015	1041	1041	1041	1041	476	485	181	115.8	110.3	111.7	112.4	0.41
51	375	519	1042	1041	1039	1039	1042	1016	1041	1041	1041	1041	496	502	191	120.7	115.8	115.1	115.8	0.69
52	376	523	1042	1041	1039	1039	1044	1018	1043	1043	1043	1043	504	508	192	125.5	119.3	115.1	113.8	1.17
53	395	553	1054	1052	1050	1055	1017	1017	1053	1054	1053	1046	514	523	215	128.2	120.0	120.0	117.8	0.41
54	396	534	1049	1048	1047	1044	1049	1022	1048	1048	1048	1048	497	504	197	133.8	122.7	122.0	117.3	0.41
55	398	534	1048	1046	1045	1044	1047	1021	1047	1046	1047	1047	500	507	191	133.8	118.6	120.0	117.3	0.41
56	397	541	1048	1047	1046	1044	1048	1021	1047	1047	1047	1047	510	517	198	130.3	119.3	120.7	117.8	0.69
57	387	580	1053	1048	1048	1042	1048	1021	1047	1047	1047	1047	559	566	260	142.0	122.7	120.0	116.4	1.86
58	386	580	1053	1049	1047	1039	1047	1022	1047	1048	1048	1046	561	567	250	142.7	126.9	117.9	113.8	2.07
59	385	578	1049	1046	1045	1039	1046	1020	1046	1046	1046	1046	555	562	250	146.2	116.5	117.9	113.6	2.07
60	394	576	1047	1047	1044	1044	1045	1019	1044	1045	1045	1046	554	558	224	137.9	122.7	118.6	112.4	1.72
61	389	594	1052	1048	1047	1044	1048	1022	1048	1048	1048	1048	579	583	258	137.9	126.2	121.3	118.7	1.86
62	388	632	1054	1049	1048	1044	1048	1022	1048	1049	1048	1049	627	628	300	144.8	117.9	122.0	114.4	3.31
63	384	616	1051	1047	1047	1044	1048	1022	1047	1048	1048	1048	608	607	248	142.0	122.7	120.0	114.1	3.31
64	391	618	1048	1043	1041	1044	1042	1017	1041	1042	1042	1042	616	614	256	142.0	1			

TABLE IV. - RADIATOR TUBE SURFACE TEMPERATURES

(a) U. S. Customary Units

RUN	TUBE	DISTANCE FROM TUBE INLET TO THERMOCOUPLE, IN.																				O-R		
		2	10	18	26	34	42	50	58	66	74	82	90	98	106	114	122	130	138	146	154		162	170
		TEMPERATURES, DEGREES RANK INE																						
1	1	1653	1637	1650	1638	1648	1649	1642	1508	1319	1201	1115	1050	998	960	926	898	873	852	834	817	0	795	354
	2	1646	1646	1645	1640	1635	1631	1623	1532	1322	1197	1108	1043	995	955	921	894	868	847	828	812	798	790	
	3	1646	1644	1644	1634	1639	1638	1624	1354	1194	1102	1028	974	933	898	868	845	825	806	784	769	760	753	
	4	1651	1642	1640	1642	1648	1648	1635	1639	1420	1223	1108	1022	968	926	893	862	836	815	797	780	768	751	
	5	1647	1634	1646	1637	1649	1637	1637	1539	1425	1227	1109	1026	968	924	889	859	834	813	795	777	764	758	
	6	1648	1639	1644	1640	1646	1649	1647	1641	1434	1238	1118	1035	975	932	895	865	841	819	799	784	770	763	
	7	1652	1649	1640	1649	1650	1646	1638	1530	1431	1249	1119	1037	974	932	896	865	839	819	799	782	768	757	
	8	1651	1583	1643	1630	1629	1631	1641	1529	1445	1251	1113	1031	974	927	890	860	835	815	795	779	764	759	
	9	1633	1648	1648	1575	1620	1625	1643	1535	1438	1240	1106	1022	962	919	883	854	830	808	789	772	759	751	
2	1	1631	1616	1629	1618	1626	1629	1621	1614	1531	1327	1195	1106	1041	993	952	919	890	867	847	828	C	805	352
	2	1625	1624	1623	1619	1615	1612	1603	1613	1574	1343	1199	1106	1043	992	951	917	888	864	842	825	809	801	
	3	1624	1623	1622	1613	1618	1618	1618	1607	1549	1301	1154	1065	1003	949	914	882	856	834	810	790	778	774	
	4	1630	1622	1619	1621	1627	1628	1615	1621	1623	1405	1211	1092	1020	967	926	889	859	837	815	797	783	777	
	5	1628	1614	1626	1616	1629	1617	1617	1622	1625	1394	1206	1091	1020	964	921	886	858	834	814	795	781	774	
	6	1628	1620	1623	1621	1626	1629	1627	1625	1519	1409	1218	1103	1026	973	928	892	866	840	819	802	786	779	
	7	1632	1628	1620	1628	1629	1624	1617	1611	1618	1425	1218	1104	1026	972	929	893	864	841	819	799	785	773	
	8	1630	1564	1622	1610	1609	1610	1621	1509	1610	1432	1211	1098	1026	967	923	888	857	837	813	796	781	774	
	9	1614	1628	1628	1556	1601	1606	1623	1518	1623	1410	1199	1087	1012	958	915	881	854	830	809	790	776	758	
3	1	1645	1628	1641	1629	1637	1640	1631	1625	1535	1537	1500	1327	1213	1136	1074	1028	988	956	928	904	C	874	350
	2	1638	1637	1635	1631	1625	1622	1613	1630	1531	1531	1516	1331	1219	1137	1076	1028	987	954	925	901	881	871	
	3	1637	1635	1634	1624	1629	1629	1630	1619	1630	1635	1561	1336	1212	1115	1065	1010	972	941	913	884	859	859	
	4	1644	1634	1631	1633	1639	1641	1625	1532	1633	1523	1638	1422	1268	1160	1086	1031	984	946	916	890	869	861	
	5	1641	1627	1638	1628	1641	1628	1627	1534	1635	1618	1538	1422	1260	1156	1083	1026	982	945	914	889	867	858	
	6	1641	1631	1635	1632	1637	1640	1638	1637	1630	1627	1539	1441	1274	1170	1093	1036	995	954	924	898	876	855	
	7	1646	1642	1632	1641	1641	1637	1630	1523	1530	1641	1644	1454	1277	1173	1097	1040	992	958	925	897	876	850	
	8	1644	1575	1635	1621	1620	1622	1632	1513	1621	1519	1611	1474	1294	1173	1094	1033	985	952	918	893	868	851	
	9	1628	1641	1641	1568	1612	1617	1634	1630	1638	1633	1635	1441	1266	1159	1084	1027	983	946	915	886	866	855	
4	1	1658	1642	1654	1641	1651	1653	1644	1638	1648	1549	1472	1323	1221	1150	1092	1046	1007	974	947	922	C	891	355
	2	1652	1649	1648	1643	1637	1634	1625	1542	1643	1543	1456	1309	1215	1143	1085	1041	1000	969	938	916	895	885	
	3	1651	1649	1647	1637	1641	1642	1644	1634	1643	1644	1457	1290	1191	1105	1063	1012	976	946	919	890	866	853	
	4	1656	1645	1643	1645	1651	1650	1637	1645	1645	1636	1651	1461	1305	1191	1113	1057	1009	967	934	908	884	875	
	5	1653	1639	1650	1640	1652	1639	1639	1645	1646	1631	1652	1475	1302	1192	1114	1052	1007	968	934	907	883	873	
	6	1653	1643	1647	1644	1649	1653	1650	1648	1641	1539	1551	1495	1318	1206	1124	1064	1020	976	943	915	891	880	
	7	1657	1653	1642	1651	1651	1647	1639	1534	1640	1651	1654	1510	1321	1208	1127	1067	1016	978	943	913	890	872	
	8	1655	1586	1646	1632	1631	1633	1643	1632	1633	1630	1622	1551	1351	1216	1129	1064	1011	975	937	910	883	875	
	9	1639	1652	1651	1577	1622	1627	1645	1541	1649	1644	1646	1520	1322	1203	1120	1057	1010	969	934	903	881	868	
5	1	1650	1633	1646	1634	1642	1644	1635	1631	1640	1543	1594	1385	1258	1174	1105	1053	1009	974	944	918	0	887	351
	2	1644	1642	1641	1635	1630	1627	1617	1635	1635	1637	1608	1392	1268	1176	1107	1054	1008	973	941	917	895	885	
	3	1643	1641	1639	1629	1632	1633	1635	1624	1635	1640	1634	1408	1261	1157	1098	1036	992	959	930	899	872	874	
	4	1649	1638	1635	1637	1644	1645	1630	1637	1638	1628	1643	1518	1336	1210	1125	1062	1009	967	933	907	884	875	
	5	1646	1631	1643	1632	1644	1633	1631	1637	1639	1625	1544	1520	1324	1208	1122	1056	1007	967	932	907	883	875	
	6	1647	1636	1640	1637	1642	1645	1643	1641	1534	1532	1644	1540	1339	1221	1132	1066	1020	974	941	914	891	881	
	7	1650	1646	1636	1644	1644	1641	1633	1528	1633	1544	1647	1554	1343	1223	1136	1072	1016	977	942	913	890	874	
	8	1648	1579	1638	1625	1624	1625	1636	1523	1625	1522	1514	1581	1367	1227	1136	1065	1009	971	935	908	883	875	
	9	1632	1645	1644	1571	1615	1620	1638	1633	1641	1537	1639	1543	1332	1210	1124	1059	1007	965	931	901	880	868	

6	1	1632	1615	1625	1615	1621	1624	1621	1612	1621	1621	1477	1330	1225	1151	1096	1050	1007	974	948	928	0	906	417
	2	1629	1623	1620	1614	1610	1606	1598	1513	1514	1614	1533	1359	1249	1164	1100	1052	1036	972	945	927	911	903	
	3	1624	1620	1618	1608	1611	1612	1610	1608	1512	1618	1614	1503	1318	1202	1126	1058	1007	973	945	921	894	896	
	4	1631	1618	1621	1616	1616	1621	1508	1517	1617	1507	1521	1510	1333	1205	1119	1058	1004	963	935	914	895	888	
	5	1629	1611	1618	1609	1623	1611	1610	1617	1619	1605	1622	1519	1327	1201	1114	1048	998	959	931	911	892	884	
	6	1628	1616	1618	1614	1620	1621	1620	1513	1613	1613	1623	1539	1341	1217	1126	1062	1013	968	941	921	902	894	
	7	1631	1624	1617	1623	1623	1622	1612	1610	1614	1525	1627	1570	1350	1222	1129	1064	1006	967	939	918	899	890	
	8	1630	1560	1618	1604	1604	1605	1614	1609	1607	1604	1594	1595	1390	1234	1134	1063	1002	965	935	915	894	887	
	9	1614	1622	1623	1551	1595	1600	1616	1513	1625	1517	1620	1577	1352	1217	1122	1054	1002	959	930	905	888	880	
7	1	1624	1607	1615	1606	1612	1613	1610	1601	1610	1613	1609	1444	1310	1220	1150	1096	1049	1013	981	953	0	918	418
	2	1620	1614	1611	1606	1602	1596	1589	1504	1504	1506	1507	1491	1341	1236	1158	1100	1049	1010	975	948	925	912	
	3	1616	1611	1609	1599	1601	1601	1599	1598	1603	1607	1604	1598	1466	1296	1202	1117	1057	1018	980	944	914	908	
	4	1623	1610	1613	1607	1606	1611	1599	1507	1505	1597	1510	1585	1479	1304	1198	1120	1057	1008	970	939	912	901	
	5	1620	1603	1610	1599	1612	1601	1600	1605	1608	1594	1611	1604	1475	1303	1194	1112	1054	1005	964	935	909	897	
	6	1619	1606	1608	1605	1609	1610	1609	1507	1502	1502	1612	1603	1494	1322	1206	1126	1069	1016	976	945	919	905	
	7	1622	1614	1606	1611	1612	1610	1601	1597	1602	1514	1616	1610	1524	1336	1214	1131	1063	1016	975	940	914	900	
	8	1621	1551	1607	1593	1593	1595	1603	1598	1595	1593	1593	1591	1577	1359	1228	1136	1063	1017	973	941	911	901	
	9	1606	1613	1614	1542	1585	1590	1606	1601	1614	1606	1609	1598	1522	1328	1207	1122	1058	1008	967	930	906	894	
8	1	1644	1625	1637	1623	1630	1632	1623	1617	1625	1529	1631	1619	1517	1377	1276	1204	1142	1095	1055	1020	0	977	357
	2	1637	1634	1632	1624	1618	1614	1605	1621	1621	1524	1522	1511	1562	1398	1288	1209	1143	1094	1049	1015	985	971	
	3	1636	1633	1630	1620	1623	1623	1624	1614	1623	1530	1622	1620	1581	1387	1270	1174	1110	1068	1026	986	951	945	
	4	1640	1629	1625	1626	1631	1631	1616	1624	1523	1515	1626	1605	1621	1586	1400	1270	1180	1114	1063	1020	986	971	
	5	1638	1622	1632	1620	1632	1619	1617	1623	1523	1510	1627	1623	1623	1596	1401	1271	1183	1116	1062	1022	985	970	
	6	1638	1627	1628	1625	1629	1631	1628	1525	1619	1617	1628	1621	1626	1615	1419	1288	1202	1127	1075	1032	997	980	
	7	1642	1635	1624	1632	1631	1626	1618	1613	1619	1630	1632	1628	1624	1626	1443	1306	1203	1136	1078	1032	996	969	
	8	1639	1569	1627	1613	1611	1612	1621	1511	1610	1608	1599	1609	1622	1615	1485	1320	1209	1142	1079	1035	993	979	
	9	1624	1634	1633	1560	1603	1607	1624	1619	1625	1521	1623	1616	1616	1617	1437	1296	1197	1125	1068	1020	986	967	
9	1	1619	1597	1604	1591	1594	1594	1589	1578	1584	1538	1586	1579	1579	1580	1494	1371	1271	1196	1132	1081	0	1023	415
	2	1615	1605	1600	1591	1584	1577	1567	1580	1579	1531	1580	1571	1582	1586	1555	1426	1308	1220	1144	1091	1048	1028	
	3	1610	1601	1597	1584	1585	1583	1578	1575	1579	1582	1578	1575	1578	1573	1585	1535	1385	1263	1184	1110	1059	1042	
	4	1617	1601	1601	1592	1590	1592	1579	1585	1581	1574	1586	1563	1578	1586	1586	1540	1371	1256	1169	1100	1047	1028	
	5	1616	1595	1598	1586	1596	1583	1580	1585	1585	1571	1585	1580	1582	1590	1585	1533	1373	1252	1161	1095	1044	1023	
	6	1614	1597	1596	1591	1592	1592	1589	1585	1579	1578	1586	1580	1585	1586	1580	1557	1403	1275	1182	1111	1057	1036	
	7	1617	1605	1594	1597	1595	1591	1580	1575	1578	1589	1589	1585	1581	1587	1579	1582	1430	1301	1197	1116	1059	1035	
	8	1615	1542	1595	1579	1578	1577	1583	1575	1573	1569	1558	1567	1583	1577	1573	1572	1442	1312	1205	1126	1051	1040	
	9	1600	1604	1601	1529	1569	1571	1584	1580	1590	1582	1583	1574	1575	1581	1578	1569	1400	1272	1174	1098	1045	1022	
10	1	1608	1584	1587	1573	1574	1571	1564	1551	1555	1556	1554	1546	1546	1550	1550	1550	1477	1357	1267	1197	0	1117	414
	2	1604	1591	1584	1573	1565	1556	1544	1554	1551	1550	1547	1538	1548	1553	1547	1549	1540	1412	1300	1223	1157	1131	
	3	1600	1588	1582	1566	1566	1559	1552	1548	1551	1551	1546	1543	1544	1541	1549	1534	1543	1505	1353	1252	1186	1156	
	4	1607	1589	1585	1576	1571	1570	1556	1562	1554	1546	1554	1531	1546	1552	1552	1553	1546	1468	1339	1239	1167	1142	
	5	1605	1581	1582	1568	1577	1560	1555	1559	1555	1541	1552	1547	1548	1556	1550	1548	1551	1485	1338	1241	1167	1137	
	6	1604	1584	1581	1573	1572	1569	1564	1558	1551	1548	1555	1548	1551	1553	1546	1547	1556	1528	1377	1269	1189	1157	
	7	1605	1592	1578	1580	1575	1569	1557	1550	1551	1550	1559	1554	1549	1554	1547	1552	1549	1552	1405	1281	1197	1153	
	8	1605	1529	1579	1561	1558	1555	1559	1551	1545	1541	1530	1537	1540	1544	1540	1542	1532	1547	1416	1292	1200	1171	
	9	1590	1591	1585	1513	1549	1550	1561	1554	1562	1552	1552	1543	1543	1549	1547	1547	1554	1519	1357	1245	1172	1140	

TABLE IV. - Continued. RADIATOR TUBE SURFACE TEMPERATURES

(a) Continued. U. S. Customary Units

RUN	TUBE	DISTANCE FROM TUBE INLET TO THERMOCOUPLE, IN.																				O-R		
		2	10	18	26	34	42	50	58	65	74	82	90	98	106	114	122	130	138	146	154		162	170
		TEMPERATURES, DEGREES RANKINE																						
11	1	1618	1593	1598	1583	1585	1582	1574	1562	1565	1568	1564	1556	1555	1559	1561	1516	1398	1298	1219	0	1135	415	
	2	1614	1602	1595	1584	1575	1566	1554	1565	1561	1561	1558	1548	1559	1562	1557	1558	1556	1441	1324	1242	1175	1151	
	3	1609	1598	1592	1577	1577	1571	1564	1560	1562	1563	1557	1554	1555	1550	1560	1544	1553	1552	1395	1280	1207	1177	
	4	1616	1597	1596	1585	1580	1581	1566	1572	1565	1556	1565	1542	1556	1562	1562	1564	1556	1535	1388	1271	1188	1152	
	5	1615	1592	1592	1579	1587	1572	1567	1569	1567	1552	1564	1558	1559	1567	1560	1559	1561	1541	1380	1272	1189	1150	
	6	1613	1595	1592	1583	1583	1581	1575	1569	1561	1559	1566	1559	1561	1562	1557	1557	1567	1549	1402	1292	1211	1181	
	7	1616	1603	1589	1590	1586	1581	1568	1561	1562	1571	1569	1564	1558	1564	1555	1561	1559	1563	1447	1313	1221	1186	
	8	1616	1539	1590	1573	1568	1566	1570	1562	1555	1552	1540	1546	1560	1554	1549	1551	1541	1557	1464	1329	1226	1196	
	9	1599	1601	1596	1523	1560	1560	1571	1564	1573	1563	1562	1552	1553	1559	1555	1555	1562	1556	1401	1277	1195	1163	
12	1	1743	1724	1741	1720	1609	1334	1180	1081	1015	965	924	890	862	839	818	800	783	769	756	744	0	728	355
	2	1736	1733	1733	1538	1239	1092	999	943	894	858	829	804	784	766	748	734	721	710	699	692	683	580	
	3	1738	1731	1730	1699	1348	1151	1035	958	909	856	834	807	784	766	745	733	724	708	692	687	687	677	
	4	1744	1731	1731	1725	1436	1205	1067	993	931	886	854	821	800	781	765	747	732	719	710	698	692	689	
	5	1740	1724	1736	1723	1734	1370	1177	1070	995	937	896	861	834	810	791	774	758	744	732	720	710	705	
	6	1740	1728	1733	1729	1735	1444	1217	1090	1004	947	904	868	839	815	795	776	761	746	732	722	711	707	
	7	1743	1740	1729	1740	1741	1528	1232	1091	999	945	897	862	830	807	786	767	750	737	723	710	701	594	
	8	1743	1664	1734	1716	1718	1522	1236	1093	997	941	892	856	829	803	783	764	747	734	719	708	698	695	
	9	1724	1740	1741	1651	1704	1414	1187	1050	975	922	877	842	815	792	772	755	739	726	712	701	693	685	
13	1	1747	1727	1744	1727	1740	1700	1419	1255	1154	1083	1026	980	943	914	887	865	844	826	811	797	0	778	354
	2	1740	1738	1736	1729	1722	1424	1234	1133	1052	995	949	911	882	857	834	815	797	783	768	757	745	740	
	3	1742	1736	1733	1720	1725	1517	1281	1150	1059	1000	951	913	883	854	832	812	799	781	761	749	744	735	
	4	1747	1735	1734	1735	1738	1641	1337	1193	1096	1022	974	926	896	870	848	827	806	791	776	763	753	748	
	5	1744	1726	1740	1728	1744	1726	1602	1330	1177	1077	1011	958	918	886	859	834	815	797	781	766	754	749	
	6	1743	1731	1736	1733	1739	1740	1670	1357	1188	1090	1020	965	923	890	862	837	817	799	782	768	756	751	
	7	1748	1744	1733	1744	1745	1741	1655	1351	1186	1097	1020	967	923	891	863	838	817	799	783	768	756	745	
	8	1747	1666	1737	1720	1723	1719	1690	1355	1185	1094	1015	962	923	888	859	836	814	797	779	766	753	749	
	9	1727	1743	1744	1656	1710	1714	1647	1345	1179	1085	1009	955	914	881	854	830	810	793	776	761	750	742	
14	1	1763	1743	1759	1743	1755	1752	1526	1341	1229	1148	1085	1035	995	966	938	914	890	870	851	833	0	810	353
	2	1755	1754	1753	1746	1740	1536	1322	1211	1113	1054	1007	971	941	912	886	863	840	821	803	788	777	770	
	3	1758	1752	1748	1735	1742	1659	1389	1239	1133	1069	1015	978	947	913	891	864	845	824	803	785	776	759	
	4	1763	1751	1749	1751	1755	1748	1480	1313	1195	1109	1052	1002	971	945	918	892	865	842	823	806	792	785	
	5	1760	1742	1755	1744	1760	1742	1741	1455	1279	1151	1083	1024	984	951	919	889	863	840	818	799	785	781	
	6	1760	1747	1753	1748	1755	1757	1756	1532	1307	1184	1098	1033	988	953	921	892	868	842	821	804	789	784	
	7	1763	1760	1748	1766	1760	1758	1745	1525	1307	1193	1098	1035	987	954	923	893	866	844	822	803	789	777	
	8	1762	1682	1753	1736	1739	1735	1750	1545	1310	1194	1094	1033	991	953	921	892	864	843	819	802	786	781	
	9	1742	1758	1760	1670	1724	1730	1752	1545	1313	1190	1093	1028	982	946	915	886	861	838	817	797	783	774	
15	1	1761	1741	1758	1741	1753	1752	1608	1425	1314	1230	1162	1107	1059	1022	987	960	934	912	891	872	0	850	351
	2	1753	1752	1750	1744	1739	1667	1439	1323	1222	1149	1091	1039	1001	968	939	913	888	868	850	835	823	815	
	3	1756	1749	1746	1734	1739	1737	1537	1368	1254	1175	1109	1056	1013	973	949	919	896	876	856	836	824	820	
	4	1761	1749	1748	1749	1753	1751	1659	1457	1317	1214	1142	1076	1028	991	958	930	901	877	858	842	827	821	
	5	1758	1740	1753	1742	1758	1741	1742	1694	1442	1288	1185	1105	1045	998	959	926	897	873	850	833	818	812	
	6	1758	1744	1750	1747	1753	1756	1755	1735	1475	1317	1204	1121	1056	1008	967	934	905	877	856	839	823	815	
	7	1761	1757	1747	1757	1758	1757	1743	1720	1471	1326	1204	1122	1055	1009	968	935	903	879	857	837	822	810	
	8	1760	1679	1751	1734	1736	1734	1747	1722	1465	1320	1195	1119	1062	1009	969	935	903	881	857	839	822	816	
	9	1740	1757	1757	1667	1722	1728	1750	1614	1400	1280	1179	1109	1054	1007	969	936	909	883	861	841	826	817	

16	1	1753	1733	1750	1733	1745	1746	1729	1475	1324	1221	1141	1080	1032	996	963	937	912	891	874	854	0	832	352	
	2	1746	1744	1743	1737	1731	1719	1499	1337	1213	1124	1061	1012	976	945	917	893	870	851	834	819	806	799		
	3	1747	1742	1739	1726	1731	1732	1608	1387	1241	1148	1077	1025	984	947	924	896	876	856	836	816	804	800		
	4	1753	1740	1740	1741	1744	1745	1727	1533	1333	1206	1122	1055	1010	976	946	919	892	868	849	833	819	812		
	5	1750	1732	1745	1734	1749	1734	1734	1726	1468	1279	1163	1081	1024	981	945	913	886	863	843	824	810	802		
	6	1749	1737	1742	1739	1745	1748	1746	1731	1490	1305	1181	1095	1034	990	952	921	896	869	848	831	815	808		
	7	1753	1749	1738	1749	1750	1748	1735	1717	1485	1315	1182	1098	1035	991	954	923	893	870	849	830	815	802		
	8	1752	1673	1742	1726	1728	1727	1740	1723	1505	1322	1180	1096	1039	990	953	922	892	871	847	830	813	808		
	9	1733	1748	1750	1660	1714	1720	1742	1725	1513	1319	1178	1090	1028	983	947	916	890	866	844	824	810	801		
17	1	1747	1727	1743	1728	1740	1740	1736	1642	1493	1359	1253	1166	1099	1055	1019	991	966	944	923	902	0	875	353	
	2	1739	1738	1736	1731	1725	1720	1708	1553	1412	1232	1180	1102	1054	1019	989	963	936	914	892	873	857	849		
	3	1741	1736	1734	1721	1725	1728	1731	1639	1491	1335	1213	1126	1068	1024	999	967	943	922	898	874	854	853		
	4	1747	1735	1734	1736	1739	1740	1723	1732	1665	1483	1310	1173	1092	1043	1008	981	950	921	896	874	856	848		
	5	1744	1726	1739	1728	1743	1728	1727	1734	1735	1546	1356	1212	1116	1055	1013	978	949	921	894	872	854	845		
	6	1743	1731	1736	1732	1739	1743	1740	1737	1727	1551	1376	1233	1132	1069	1023	989	961	929	904	881	862	853		
	7	1748	1743	1733	1744	1743	1743	1729	1721	1723	1556	1374	1235	1130	1068	1023	990	958	932	904	880	861	845		
	8	1746	1667	1738	1721	1722	1722	1734	1721	1720	1558	1375	1236	1138	1066	1022	989	956	932	904	881	859	852		
	9	1727	1743	1744	1655	1709	1715	1736	1727	1563	1540	1348	1213	1115	1052	1015	983	956	928	903	877	859	848		
18	1	1741	1722	1736	1723	1732	1735	1733	1718	1665	1480	1346	1245	1170	1116	1071	1033	1000	974	949	928	0	901	413	
	2	1737	1732	1729	1723	1719	1714	1706	1721	1573	1480	1344	1240	1170	1116	1069	1033	998	971	945	925	908	898		
	3	1739	1732	1729	1716	1720	1725	1725	1713	1527	1362	1241	1161	1102	1048	1017	978	952	930	907	885	863	862		
	4	1744	1729	1729	1727	1724	1733	1716	1729	1731	1709	1490	1315	1215	1138	1080	1037	995	961	934	912	892	883		
	5	1741	1722	1730	1720	1736	1722	1721	1729	1732	1707	1494	1327	1218	1139	1080	1032	994	962	932	910	890	881		
	6	1739	1725	1729	1726	1732	1734	1733	1730	1724	1718	1517	1345	1232	1154	1091	1044	1008	972	943	920	901	891		
	7	1742	1737	1724	1735	1736	1734	1722	1718	1725	1734	1522	1353	1232	1155	1094	1047	1004	973	944	918	899	889		
	8	1742	1664	1730	1713	1713	1714	1725	1719	1717	1710	1574	1383	1266	1168	1102	1051	1005	975	943	919	896	890		
	9	1723	1734	1737	1650	1703	1710	1730	1724	1740	1726	1566	1370	1248	1159	1096	1046	1005	970	940	912	894	882		
19	1	1748	1729	1741	1728	1737	1740	1736	1725	1735	1737	1651	1469	1341	1254	1188	1136	1089	1052	1019	990	0	955	412	
	2	1743	1737	1735	1729	1723	1719	1711	1728	1727	1728	1650	1463	1344	1256	1188	1137	1090	1052	1016	990	966	954		
	3	1745	1736	1733	1720	1724	1729	1729	1722	1725	1731	1653	1459	1326	1234	1175	1114	1066	1036	1004	972	941	944		
	4	1750	1734	1733	1733	1728	1738	1721	1734	1734	1722	1737	1631	1458	1319	1229	1160	1103	1057	1019	986	959	949		
	5	1749	1728	1736	1726	1742	1727	1725	1734	1735	1717	1738	1652	1459	1322	1230	1157	1104	1057	1016	987	958	948		
	6	1746	1732	1736	1731	1736	1739	1738	1734	1727	1727	1739	1694	1486	1346	1245	1174	1122	1070	1030	998	971	960		
	7	1748	1742	1730	1740	1740	1739	1727	1723	1723	1743	1745	1727	1504	1359	1256	1183	1121	1076	1033	997	970	957		
	8	1748	1669	1734	1717	1718	1720	1731	1724	1720	1717	1705	1712	1576	1394	1279	1197	1127	1083	1036	1002	969	959		
	9	1729	1741	1743	1655	1709	1715	1734	1729	1745	1733	1737	1717	1516	1363	1257	1180	1120	1070	1028	991	964	949		
20	1	1741	1720	1731	1717	1726	1727	1722	1710	1719	1724	1720	1713	1712	1706	1523	1413	1321	1254	1200	1152	0	1097	409	
	2	1735	1729	1725	1718	1712	1706	1697	1713	1711	1715	1713	1701	1717	1717	1551	1429	1333	1263	1202	1155	1115	1101		
	3	1735	1726	1722	1709	1711	1716	1713	1705	1708	1717	1710	1708	1711	1701	1700	1470	1369	1280	1224	1168	1130	1115		
	4	1741	1726	1723	1721	1716	1725	1708	1720	1720	1719	1707	1720	1695	1712	1720	1714	1528	1398	1304	1234	1175	1127		1113
	5	1740	1718	1725	1713	1728	1713	1711	1720	1720	1704	1721	1715	1716	1726	1717	1523	1400	1306	1231	1175	1129	1110		
	6	1738	1722	1725	1721	1725	1727	1724	1720	1712	1712	1722	1715	1719	1722	1713	1546	1428	1323	1247	1190	1143	1125		
	7	1740	1733	1720	1729	1728	1726	1713	1708	1712	1726	1726	1723	1715	1723	1713	1583	1436	1340	1259	1195	1147	1129		
	8	1740	1659	1724	1707	1706	1706	1717	1710	1704	1701	1688	1700	1719	1710	1707	1688	1464	1365	1275	1212	1154	1140		
	9	1720	1731	1732	1645	1696	1702	1719	1714	1729	1718	1719	1707	1709	1715	1712	1564	1431	1328	1244	1180	1136	1115		

TABLE IV. - Continued. RADIATOR TUBE SURFACE TEMPERATURES

(a) Continued. U. S. Customary Units

RUN	TUBE	DISTANCE FROM TUBE INLET TO THERMOCOUPLE, IN.																			O-R			
		2	10	18	26	34	42	50	58	66	74	82	90	98	106	114	122	130	138	146		154	162	170
		TEMPERATURES, DEGREES RANKINE																						
21	1	1740	1717	1727	1712	1719	1721	1716	1704	1712	1717	1713	1705	1705	1703	1652	1530	1419	1341	1279	1231	0	1171	407
	2	1735	1727	1722	1714	1707	1701	1691	1708	1705	1709	1706	1694	1710	1714	1703	1630	1486	1379	1297	1244	1194	1175	
	3	1735	1725	1720	1706	1707	1711	1708	1702	1702	1710	1704	1701	1704	1697	1713	1674	1565	1436	1335	1263	1218	1197	
	4	1741	1724	1721	1719	1713	1720	1703	1715	1713	1701	1713	1689	1706	1714	1711	1708	1579	1435	1343	1267	1211	1193	
	5	1740	1716	1723	1711	1725	1710	1706	1714	1714	1697	1714	1709	1710	1720	1712	1703	1593	1445	1340	1270	1212	1191	
	6	1737	1720	1723	1718	1721	1722	1719	1714	1707	1705	1715	1708	1713	1716	1708	1704	1639	1476	1365	1291	1232	1211	
	7	1741	1733	1718	1727	1725	1723	1708	1703	1703	1721	1721	1718	1711	1719	1709	1711	1672	1522	1394	1304	1244	1221	
	8	1740	1659	1723	1704	1704	1703	1712	1705	1699	1696	1684	1694	1714	1705	1702	1697	1677	1555	1413	1323	1252	1235	
	9	1720	1730	1730	1642	1692	1698	1715	1709	1722	1712	1713	1700	1702	1708	1704	1701	1620	1482	1365	1281	1227	1201	
22	1	1740	1714	1723	1706	1714	1713	1708	1695	1704	1709	1705	1698	1697	1698	1690	1597	1487	1420	1364	1313	0	1254	405
	2	1734	1725	1720	1712	1704	1697	1686	1702	1700	1702	1699	1687	1701	1707	1702	1695	1649	1541	1434	1358	1295	1274	
	3	1734	1723	1718	1704	1704	1707	1704	1695	1697	1704	1696	1694	1696	1689	1704	1679	1682	1612	1476	1376	1323	1290	
	4	1741	1723	1718	1715	1709	1716	1698	1709	1705	1695	1706	1680	1696	1706	1701	1705	1695	1582	1466	1374	1313	1293	
	5	1739	1715	1721	1708	1720	1705	1702	1708	1708	1690	1706	1700	1701	1712	1703	1700	1701	1604	1467	1384	1315	1294	
	6	1736	1720	1721	1714	1717	1718	1714	1709	1700	1699	1709	1701	1705	1708	1698	1699	1711	1626	1498	1406	1339	1314	
	7	1739	1731	1716	1724	1722	1718	1704	1698	1701	1715	1714	1710	1702	1711	1699	1705	1702	1654	1524	1414	1345	1319	
	8	1739	1657	1720	1701	1699	1699	1706	1698	1693	1689	1676	1686	1704	1697	1692	1689	1679	1675	1529	1427	1343	1327	
	9	1719	1727	1726	1639	1687	1693	1708	1702	1714	1704	1705	1693	1693	1700	1697	1697	1695	1569	1450	1360	1304	1280	
23	1	1739	1714	1723	1707	1714	1713	1707	1695	1704	1707	1704	1697	1696	1699	1696	1611	1503	1427	1361	1303	0	1241	405
	2	1734	1725	1720	1711	1704	1697	1685	1702	1703	1702	1698	1687	1700	1706	1702	1696	1666	1541	1428	1351	1285	1253	
	3	1735	1723	1718	1704	1704	1707	1704	1695	1697	1703	1695	1693	1694	1689	1703	1678	1685	1607	1476	1372	1315	1281	
	4	1741	1724	1719	1716	1709	1716	1698	1709	1705	1694	1705	1679	1696	1705	1700	1705	1698	1584	1470	1371	1302	1280	
	5	1738	1715	1721	1707	1720	1705	1700	1708	1705	1689	1705	1700	1700	1711	1702	1699	1705	1605	1472	1380	1305	1281	
	6	1736	1718	1720	1714	1717	1718	1714	1708	1700	1698	1708	1700	1704	1708	1698	1698	1711	1636	1504	1405	1330	1302	
	7	1739	1731	1715	1724	1721	1719	1704	1698	1702	1715	1714	1709	1702	1710	1699	1704	1701	1670	1533	1418	1341	1312	
	8	1739	1658	1720	1702	1700	1699	1707	1699	1693	1689	1675	1685	1703	1695	1691	1689	1679	1693	1537	1434	1343	1323	
	9	1720	1727	1727	1640	1688	1693	1708	1701	1714	1703	1705	1692	1693	1699	1695	1697	1698	1583	1465	1366	1302	1273	
24	1	1753	1735	1748	1725	1702	1609	1504	1399	1315	1247	1188	1139	1099	1068	1039	1015	993	974	955	938	0	915	421
	2	1749	1743	1743	1732	1703	1626	1513	1425	1325	1247	1182	1130	1092	1058	1028	1005	980	961	939	924	908	900	
	3	1749	1741	1737	1723	1717	1666	1565	1443	1330	1241	1165	1112	1070	1031	1009	979	957	940	919	897	879	877	
	4	1754	1740	1743	1736	1721	1691	1605	1454	1317	1208	1129	1062	1021	991	960	934	905	885	866	852	838	833	
	5	1753	1733	1741	1730	1746	1730	1702	1551	1419	1277	1170	1089	1036	996	961	929	902	879	859	843	830	825	
	6	1750	1737	1741	1737	1744	1743	1734	1632	1452	1313	1201	1115	1053	1009	972	941	914	888	868	851	836	831	
	7	1752	1747	1736	1745	1746	1741	1716	1600	1441	1314	1194	1112	1050	1009	971	942	912	890	870	851	837	831	
	8	1752	1672	1739	1722	1722	1714	1658	1534	1383	1277	1171	1105	1057	1014	980	952	922	902	881	865	848	844	
	9	1734	1746	1749	1658	1705	1629	1514	1375	1272	1196	1128	1070	1026	994	967	941	920	899	880	862	849	843	
25	1	1755	1736	1749	1735	1744	1734	1603	1473	1384	1295	1225	1168	1124	1091	1059	1031	1005	985	964	945	0	921	422
	2	1749	1745	1742	1736	1732	1718	1654	1510	1403	1302	1222	1161	1119	1084	1049	1021	994	972	949	932	915	905	
	3	1750	1742	1738	1726	1731	1732	1721	1552	1429	1313	1214	1152	1106	1062	1034	999	974	955	932	908	890	887	
	4	1756	1742	1744	1740	1738	1742	1722	1555	1467	1326	1202	1122	1072	1032	994	964	932	907	885	868	852	845	
	5	1753	1734	1743	1732	1749	1734	1734	1731	1583	1408	1260	1159	1096	1047	1005	970	941	914	890	871	855	848	
	6	1752	1738	1742	1738	1744	1747	1746	1733	1608	1434	1289	1181	1113	1062	1019	983	956	926	902	883	865	858	
	7	1753	1748	1736	1745	1746	1744	1733	1718	1552	1427	1273	1177	1107	1060	1017	985	952	928	903	883	866	858	
	8	1754	1674	1740	1723	1723	1724	1733	1660	1487	1369	1233	1157	1107	1059	1020	987	955	934	910	892	874	868	
	9	1736	1748	1750	1660	1715	1706	1578	1457	1340	1239	1163	1108	1066	1032	1001	974	951	928	907	887	873	865	

26	1	1753	1734	1748	1734	1744	1743	1702	1518	1411	1326	1256	1196	1146	1107	1070	1040	1013	991	971	952	0	928	423
	2	1748	1743	1741	1734	1730	1723	1704	1572	1433	1334	1257	1192	1143	1099	1059	1029	1001	979	956	939	923	914	
	3	1749	1741	1738	1725	1730	1734	1731	1683	1493	1365	1266	1195	1137	1083	1048	1009	982	963	941	917	894	895	
	4	1755	1740	1743	1739	1736	1743	1728	1731	1590	1409	1282	1182	1113	1059	1016	984	952	925	903	883	865	859	
	5	1752	1732	1740	1730	1747	1732	1731	1737	1718	1470	1324	1216	1137	1075	1027	989	960	934	908	888	870	852	
	6	1750	1737	1740	1736	1743	1745	1744	1738	1719	1493	1345	1235	1156	1093	1042	1004	975	945	921	900	881	873	
	7	1751	1746	1735	1744	1745	1743	1732	1724	1695	1481	1331	1230	1148	1089	1040	1004	970	945	921	899	881	872	
	8	1753	1673	1740	1723	1722	1724	1736	1719	1559	1412	1286	1236	1145	1084	1038	1003	970	949	925	906	887	881	
	9	1734	1746	1749	1660	1715	1717	1675	1495	1372	1283	1208	1143	1087	1043	1009	982	960	938	917	896	882	874	
27	1	1746	1727	1739	1724	1734	1725	1660	1559	1494	1430	1370	1312	1266	1229	1194	1165	1135	1113	1091	1071	0	1045	439
	2	1741	1734	1732	1725	1721	1712	1691	1641	1561	1454	1385	1309	1258	1212	1170	1139	1106	1080	1053	1034	1015	1006	
	3	1742	1731	1728	1716	1719	1724	1722	1709	1649	1559	1441	1328	1250	1191	1151	1104	1067	1047	1021	993	969	969	
	4	1746	1731	1733	1729	1724	1733	1717	1728	1725	1632	1517	1368	1277	1203	1146	1100	1059	1026	997	973	949	941	
	5	1744	1724	1731	1720	1737	1722	1721	1728	1725	1642	1521	1383	1280	1203	1144	1094	1055	1022	992	969	947	938	
	6	1741	1729	1732	1728	1733	1735	1733	1729	1719	1650	1533	1395	1292	1217	1155	1108	1072	1033	1005	981	959	950	
	7	1744	1738	1726	1735	1736	1734	1722	1715	1709	1625	1490	1370	1268	1204	1148	1104	1063	1033	1004	979	958	949	
	8	1744	1665	1730	1713	1713	1714	1726	1707	1621	1518	1399	1313	1252	1191	1146	1108	1068	1045	1018	998	975	969	
	9	1726	1737	1739	1651	1704	1707	1717	1601	1509	1430	1360	1292	1242	1200	1163	1131	1103	1077	1052	1028	1013	1006	
28	1	1746	1726	1739	1724	1735	1737	1730	1645	1525	1439	1365	1298	1244	1203	1163	1133	1102	1078	1054	1033	0	1005	430
	2	1741	1735	1732	1725	1721	1716	1707	1712	1618	1488	1387	1304	1244	1192	1147	1112	1078	1050	1021	1000	981	972	
	3	1742	1733	1729	1717	1719	1726	1725	1719	1718	1679	1476	1343	1255	1186	1140	1091	1050	1026	999	970	942	945	
	4	1746	1732	1733	1729	1726	1733	1718	1731	1733	1714	1576	1386	1288	1203	1142	1094	1048	1011	981	956	934	925	
	5	1744	1725	1732	1721	1737	1722	1721	1730	1733	1710	1575	1396	1287	1202	1140	1088	1046	1009	977	954	931	921	
	6	1741	1728	1732	1728	1734	1736	1734	1731	1725	1718	1580	1407	1298	1215	1150	1100	1061	1020	990	965	943	933	
	7	1745	1739	1727	1736	1736	1735	1723	1718	1724	1718	1533	1386	1279	1203	1141	1095	1051	1018	988	962	941	932	
	8	1746	1666	1731	1714	1714	1715	1728	1720	1711	1577	1431	1328	1256	1185	1134	1093	1050	1024	995	974	951	945	
	9	1726	1737	1740	1652	1705	1711	1731	1711	1548	1432	1338	1263	1205	1159	1121	1086	1056	1027	1000	977	960	952	
29	1	1755	1735	1748	1734	1745	1746	1743	1655	1491	1382	1307	1240	1185	1142	1104	1073	1045	1022	999	977	0	947	424
	2	1749	1744	1742	1735	1731	1725	1717	1710	1541	1404	1316	1243	1189	1140	1098	1067	1036	1011	983	962	941	930	
	3	1750	1741	1738	1725	1728	1735	1736	1728	1714	1518	1367	1268	1195	1133	1092	1048	1015	991	963	933	907	906	
	4	1755	1741	1743	1739	1735	1744	1727	1740	1742	1624	1397	1270	1192	1126	1073	1035	998	963	934	910	888	879	
	5	1753	1734	1740	1731	1748	1733	1731	1740	1743	1672	1439	1303	1213	1141	1086	1043	1007	973	941	917	894	885	
	6	1750	1738	1741	1737	1743	1745	1744	1740	1735	1710	1453	1316	1227	1156	1098	1056	1023	986	955	930	906	896	
	7	1753	1747	1736	1746	1746	1744	1733	1727	1735	1682	1435	1312	1217	1150	1095	1055	1017	985	954	926	905	894	
	8	1753	1674	1740	1723	1722	1724	1737	1729	1722	1588	1373	1281	1209	1139	1089	1051	1013	987	956	930	906	898	
	9	1735	1746	1749	1660	1714	1720	1741	1718	1489	1363	1279	1200	1136	1088	1055	1023	995	965	936	910	891	883	
30	1	1745	1725	1736	1723	1732	1733	1725	1586	1555	1476	1408	1347	1298	1261	1225	1194	1163	1138	1114	1091	0	1063	440
	2	1740	1733	1731	1724	1719	1713	1705	1715	1598	1590	1453	1364	1306	1254	1207	1170	1132	1102	1070	1048	1026	1018	
	3	1740	1730	1727	1715	1718	1724	1723	1716	1715	1716	1643	1467	1349	1265	1211	1151	1103	1073	1042	1009	979	980	
	4	1745	1731	1731	1727	1722	1731	1715	1727	1729	1713	1712	1491	1376	1279	1213	1157	1107	1065	1030	1002	976	967	
	5	1742	1723	1729	1719	1735	1720	1719	1727	1730	1710	1713	1505	1373	1280	1213	1154	1105	1063	1026	1000	974	963	
	6	1740	1727	1730	1726	1731	1733	1730	1727	1721	1718	1717	1516	1386	1293	1221	1167	1122	1074	1039	1011	985	975	
	7	1743	1737	1725	1734	1734	1732	1721	1715	1721	1734	1687	1485	1356	1275	1210	1161	1109	1073	1037	1008	984	974	
	8	1743	1664	1729	1711	1711	1712	1724	1715	1712	1674	1492	1387	1313	1245	1195	1152	1107	1078	1047	1023	997	991	
	9	1726	1735	1737	1649	1702	1705	1723	1705	1609	1494	1411	1338	1287	1243	1206	1172	1142	1112	1084	1057	1039	1031	

TABLE IV. - Continued. RADIATOR TUBE SURFACE TEMPERATURES

(a) Continued. U. S. Customary Units

RUN	TUBE	DISTANCE FROM TUBE INLET TO THERMOCOUPLE, IN.																			O-R			
		2	10	18	26	34	42	50	58	66	74	82	90	98	106	114	122	130	138	146		154	162	170
		TEMPERATURES, DEGREES RANKINE																						
31	1	1744	1725	1737	1722	1733	1734	1731	1709	1588	1534	1413	1332	1273	1229	1187	1151	1117	1092	1066	1044	0	1015	429
	2	1740	1733	1731	1724	1719	1714	1705	1719	1709	1531	1473	1363	1287	1228	1175	1135	1096	1065	1034	1011	990	981	
	3	1738	1730	1727	1715	1717	1723	1723	1715	1718	1718	1628	1491	1345	1243	1183	1122	1074	1048	1018	987	958	958	
	4	1744	1730	1731	1727	1723	1730	1715	1728	1729	1715	1717	1502	1376	1263	1190	1131	1081	1041	1007	980	956	947	
	5	1742	1722	1730	1719	1736	1720	1719	1727	1731	1711	1717	1512	1371	1263	1188	1126	1078	1037	1002	977	953	943	
	6	1740	1726	1729	1725	1731	1733	1731	1728	1721	1720	1720	1523	1384	1276	1198	1139	1094	1049	1015	988	964	954	
	7	1743	1737	1725	1735	1735	1733	1721	1715	1722	1733	1630	1517	1358	1262	1189	1134	1083	1048	1013	984	962	952	
	8	1743	1663	1728	1712	1711	1712	1724	1718	1713	1700	1528	1424	1317	1232	1172	1123	1076	1047	1015	991	966	950	
	9	1724	1734	1737	1650	1702	1708	1727	1717	1724	1545	1432	1320	1248	1193	1146	1107	1073	1043	1014	989	971	963	
32	1	1743	1724	1736	1722	1731	1733	1727	1674	1570	1485	1407	1338	1285	1243	1203	1170	1137	1113	1089	1067	0	1039	438
	2	1738	1732	1729	1723	1718	1713	1704	1713	1679	1556	1457	1361	1297	1241	1188	1150	1111	1083	1053	1030	1009	1000	
	3	1739	1729	1726	1714	1717	1722	1721	1715	1715	1716	1599	1468	1350	1263	1202	1139	1092	1066	1034	1001	971	970	
	4	1743	1729	1730	1726	1721	1729	1714	1727	1723	1713	1649	1492	1374	1275	1202	1143	1094	1055	1021	993	967	958	
	5	1741	1721	1729	1718	1734	1719	1718	1727	1729	1729	1646	1504	1372	1275	1200	1138	1092	1052	1017	991	965	956	
	6	1739	1725	1728	1724	1729	1732	1729	1727	1720	1718	1651	1517	1383	1289	1210	1150	1107	1063	1029	1002	977	967	
	7	1741	1735	1724	1733	1733	1731	1719	1714	1720	1730	1636	1485	1355	1270	1199	1145	1095	1060	1026	998	974	965	
	8	1741	1663	1727	1710	1710	1712	1723	1715	1712	1648	1502	1396	1314	1238	1181	1135	1089	1062	1031	1007	982	975	
	9	1724	1734	1736	1649	1700	1707	1725	1711	1628	1529	1424	1337	1274	1222	1177	1139	1107	1078	1050	1024	1005	997	
33	1	1751	1730	1741	1727	1736	1739	1735	1709	1631	1541	1459	1390	1334	1290	1249	1215	1182	1158	1134	1111	0	1083	441
	2	1745	1738	1735	1728	1723	1718	1708	1724	1714	1692	1559	1449	1370	1300	1241	1197	1155	1124	1092	1067	1043	1033	
	3	1746	1735	1731	1719	1722	1727	1726	1720	1722	1731	1721	1662	1474	1342	1264	1189	1138	1107	1075	1040	1009	1006	
	4	1750	1735	1736	1731	1726	1734	1719	1732	1732	1723	1648	1483	1354	1268	1198	1145	1102	1066	1035	1006	995		
	5	1747	1728	1734	1724	1740	1725	1723	1731	1733	1715	1731	1671	1485	1358	1267	1195	1143	1099	1061	1032	1004	992	
	6	1746	1732	1735	1731	1735	1738	1734	1732	1725	1725	1733	1683	1503	1377	1280	1210	1161	1111	1074	1044	1015	1004	
	7	1748	1742	1729	1739	1738	1736	1723	1719	1725	1739	1734	1634	1453	1347	1262	1200	1145	1108	1071	1039	1013	1002	
	8	1749	1669	1733	1716	1715	1717	1728	1721	1718	1736	1626	1473	1383	1297	1234	1185	1137	1110	1076	1052	1023	1018	
	9	1730	1740	1741	1652	1706	1711	1728	1714	1707	1583	1475	1389	1327	1276	1232	1194	1163	1134	1105	1080	1062	1055	
34	1	1744	1725	1736	1722	1731	1734	1731	1708	1630	1542	1465	1382	1319	1271	1227	1190	1155	1129	1104	1081	0	1052	437
	2	1740	1733	1730	1723	1719	1713	1704	1721	1715	1676	1554	1439	1354	1284	1223	1176	1133	1101	1068	1044	1020	1011	
	3	1740	1729	1726	1715	1717	1722	1722	1715	1717	1722	1711	1585	1454	1331	1256	1179	1126	1096	1063	1027	997	993	
	4	1744	1730	1731	1727	1722	1730	1715	1727	1729	1714	1725	1581	1470	1340	1256	1184	1130	1089	1053	1021	993	983	
	5	1742	1723	1729	1718	1735	1720	1719	1727	1729	1711	1727	1593	1468	1341	1253	1180	1128	1086	1048	1019	990	979	
	6	1740	1726	1729	1725	1730	1733	1730	1727	1721	1720	1729	1639	1482	1356	1264	1193	1145	1097	1061	1029	1002	991	
	7	1742	1736	1724	1733	1733	1731	1719	1715	1723	1734	1725	1578	1453	1336	1250	1186	1131	1094	1057	1025	999	988	
	8	1742	1664	1728	1711	1710	1712	1723	1717	1712	1733	1595	1491	1392	1293	1225	1169	1120	1092	1057	1032	1004	997	
	9	1724	1735	1736	1649	1701	1707	1725	1715	1724	1532	1523	1408	1327	1263	1210	1165	1129	1098	1068	1041	1021	1013	
35	1	1745	1724	1736	1723	1732	1734	1729	1717	1715	1545	1426	1344	1287	1246	1205	1167	1129	1101	1073	1051	0	1020	428
	2	1740	1733	1731	1723	1719	1714	1704	1721	1722	1711	1521	1384	1307	1250	1196	1150	1107	1075	1043	1020	998	988	
	3	1740	1729	1726	1714	1717	1722	1722	1716	1717	1725	1720	1677	1370	1276	1217	1146	1093	1065	1034	1002	973	971	
	4	1744	1729	1730	1727	1721	1730	1714	1727	1723	1715	1730	1677	1397	1288	1220	1156	1100	1059	1025	996	969	960	
	5	1742	1723	1729	1718	1735	1720	1718	1727	1723	1712	1732	1695	1391	1289	1219	1150	1098	1056	1020	993	967	957	
	6	1740	1726	1730	1725	1731	1733	1731	1728	1723	1721	1732	1695	1405	1302	1229	1165	1115	1067	1033	1004	978	958	
	7	1743	1737	1726	1734	1733	1732	1720	1715	1723	1735	1737	1695	1382	1292	1223	1162	1104	1066	1031	1001	976	965	
	8	1743	1662	1727	1711	1709	1711	1722	1715	1712	1708	1690	1597	1342	1264	1206	1150	1096	1063	1030	1005	978	971	
	9	1724	1735	1737	1649	1701	1707	1726	1720	1735	1714	1467	1342	1275	1226	1177	1131	1091	1058	1030	1002	983	975	

36	1	1747	1727	1738	1723	1734	1735	1732	1703	1631	1552	1481	1413	1355	1310	1267	1232	1197	1171	1145	1121	0	1090	442
	2	1741	1735	1733	1725	1720	1716	1705	1722	1713	1698	1605	1493	1410	1331	1264	1215	1167	1133	1096	1071	1045	1034	
	3	1742	1731	1728	1715	1718	1723	1722	1716	1718	1727	1720	1655	1515	1397	1302	1217	1159	1124	1089	1052	1018	1011	
	4	1747	1732	1733	1729	1724	1732	1716	1729	1730	1715	1731	1642	1517	1401	1302	1226	1166	1120	1082	1047	1014	1032	
	5	1745	1725	1731	1720	1736	1722	1720	1728	1730	1712	1732	1666	1523	1406	1302	1223	1166	1118	1076	1044	1012	998	
	6	1743	1728	1732	1727	1732	1735	1732	1729	1722	1721	1733	1686	1542	1428	1316	1239	1183	1129	1089	1055	1024	1011	
	7	1745	1739	1727	1736	1735	1733	1721	1715	1722	1735	1733	1636	1497	1393	1295	1228	1167	1126	1087	1051	1022	1009	
	8	1745	1665	1730	1713	1711	1712	1724	1717	1714	1735	1619	1534	1428	1330	1259	1206	1154	1124	1089	1061	1031	1024	
	9	1728	1737	1739	1650	1703	1708	1725	1712	1685	1579	1496	1415	1351	1298	1252	1213	1179	1148	1118	1091	1072	1055	
37	1	1748	1727	1738	1725	1734	1737	1734	1716	1722	1659	1527	1399	1329	1278	1230	1188	1148	1119	1090	1066	0	1035	427
	2	1742	1737	1734	1727	1722	1717	1708	1725	1723	1713	1648	1477	1380	1303	1234	1179	1130	1094	1059	1035	1011	1030	
	3	1743	1733	1730	1718	1720	1726	1725	1719	1720	1728	1716	1692	1486	1354	1276	1193	1130	1092	1057	1022	993	989	
	4	1748	1732	1734	1730	1725	1733	1717	1730	1731	1718	1726	1684	1532	1363	1277	1200	1137	1088	1051	1020	991	980	
	5	1745	1725	1732	1722	1738	1723	1722	1730	1732	1715	1726	1705	1531	1364	1274	1195	1134	1085	1046	1017	989	978	
	6	1743	1729	1733	1728	1733	1735	1733	1729	1723	1722	1728	1737	1550	1379	1285	1210	1152	1096	1059	1028	1000	989	
	7	1746	1740	1729	1737	1738	1736	1724	1718	1724	1738	1734	1709	1536	1369	1279	1208	1141	1096	1057	1026	998	987	
	8	1746	1666	1732	1715	1713	1715	1726	1720	1715	1739	1692	1651	1447	1337	1259	1191	1127	1091	1054	1027	998	993	
	9	1727	1738	1740	1652	1704	1710	1729	1722	1733	1718	1636	1504	1360	1285	1219	1161	1115	1078	1046	1016	996	987	
38	1	1746	1726	1737	1723	1732	1735	1731	1718	1711	1612	1488	1418	1363	1312	1258	1216	1177	1149	1121	1097	0	1064	435
	2	1741	1733	1731	1724	1719	1714	1704	1722	1723	1719	1672	1496	1412	1346	1270	1211	1159	1121	1085	1057	1031	1020	
	3	1741	1731	1727	1715	1717	1723	1723	1715	1717	1726	1721	1704	1545	1395	1318	1224	1163	1124	1086	1046	1014	1008	
	4	1745	1731	1732	1728	1722	1731	1715	1727	1727	1715	1730	1687	1531	1399	1320	1230	1166	1119	1078	1043	1012	1032	
	5	1743	1723	1730	1719	1734	1720	1718	1727	1728	1711	1731	1707	1530	1402	1318	1226	1165	1115	1072	1040	1009	998	
	6	1741	1728	1730	1726	1731	1733	1730	1727	1721	1720	1732	1709	1550	1415	1331	1243	1184	1129	1087	1053	1023	1011	
	7	1744	1738	1725	1734	1734	1733	1720	1715	1721	1735	1737	1706	1511	1414	1320	1238	1172	1126	1084	1048	1020	1008	
	8	1744	1664	1729	1711	1711	1712	1723	1717	1712	1738	1694	1600	1446	1376	1294	1220	1158	1122	1083	1053	1020	1013	
	9	1726	1735	1737	1649	1701	1708	1726	1720	1735	1715	1605	1446	1380	1330	1263	1205	1161	1124	1089	1058	1035	1026	
39	1	1746	1726	1738	1724	1733	1736	1733	1717	1677	1586	1513	1464	1375	1304	1249	1208	1167	1136	1106	1079	0	1044	431
	2	1740	1734	1732	1725	1720	1715	1705	1723	1723	1736	1634	1517	1445	1337	1259	1206	1156	1117	1079	1051	1024	1013	
	3	1741	1732	1727	1715	1718	1724	1724	1713	1718	1726	1721	1621	1517	1421	1304	1217	1163	1122	1085	1046	1015	1009	
	4	1745	1732	1732	1729	1724	1732	1717	1729	1730	1717	1729	1592	1519	1429	1308	1228	1168	1121	1079	1044	1013	1032	
	5	1744	1724	1731	1720	1736	1721	1720	1729	1730	1713	1731	1608	1530	1425	1304	1224	1166	1116	1074	1041	1011	999	
	6	1741	1728	1732	1727	1732	1735	1732	1729	1723	1722	1732	1618	1528	1441	1316	1237	1183	1129	1087	1053	1023	1012	
	7	1744	1738	1727	1736	1736	1733	1722	1717	1722	1736	1737	1613	1515	1451	1321	1242	1177	1131	1088	1050	1020	1009	
	8	1744	1665	1730	1712	1712	1714	1724	1713	1714	1710	1694	1569	1508	1457	1324	1239	1174	1134	1089	1055	1019	1011	
	9	1726	1737	1738	1651	1702	1709	1728	1722	1737	1720	1621	1520	1504	1403	1288	1217	1166	1121	1081	1044	1016	1034	
40	1	1746	1725	1735	1721	1730	1733	1730	1715	1714	1640	1538	1461	1396	1343	1295	1256	1216	1188	1160	1135	0	1103	443
	2	1740	1734	1730	1723	1718	1713	1703	1720	1721	1719	1706	1640	1506	1406	1323	1261	1205	1163	1121	1091	1061	1051	
	3	1742	1731	1727	1714	1717	1721	1720	1715	1716	1725	1719	1708	1648	1496	1386	1280	1216	1166	1125	1083	1050	1041	
	4	1745	1731	1731	1726	1721	1729	1714	1725	1727	1714	1729	1696	1654	1492	1382	1287	1215	1162	1117	1079	1046	1035	
	5	1744	1724	1730	1719	1734	1720	1718	1725	1727	1713	1732	1719	1672	1502	1381	1286	1216	1159	1112	1078	1044	1031	
	6	1743	1728	1731	1726	1731	1733	1729	1727	1720	1720	1731	1718	1675	1520	1398	1302	1236	1173	1126	1088	1056	1044	
	7	1744	1737	1725	1734	1733	1731	1718	1714	1719	1734	1735	1721	1632	1485	1374	1288	1216	1166	1121	1082	1052	1040	
	8	1744	1665	1729	1711	1709	1711	1722	1715	1712	1737	1691	1650	1519	1410	1325	1258	1195	1158	1116	1085	1054	1048	
	9	1725	1735	1736	1648	1700	1706	1724	1714	1727	1597	1580	1484	1411	1349	1294	1247	1207	1171	1138	1107	1087	1078	

TABLE IV. - Continued. RADIATOR TUBE SURFACE TEMPERATURES

(a) Continued. U. S. Customary Units

RUN	TUBE	DISTANCE FROM TUBE INLET TO THERMOCOUPLE, IN.																	O-R					
		2	10	18	26	34	42	50	58	66	74	82	90	98	106	114	122	130		138	146	154	162	170
		TEMPERATURES, DEGREES RANKINE																						
41	1	1748	1728	1740	1727	1735	1738	1734	1721	1731	1674	1534	1425	1354	1297	1243	1197	1155	1125	1096	1070	0	1035	425
	2	1743	1736	1733	1727	1722	1717	1707	1724	1725	1725	1712	1507	1396	1323	1255	1199	1148	1110	1072	1045	1020	1007	
	3	1742	1733	1730	1717	1720	1726	1725	1719	1720	1728	1722	1679	1495	1365	1294	1213	1154	1115	1079	1040	1008	1003	
	4	1748	1734	1735	1731	1725	1734	1717	1730	1731	1719	1734	1697	1521	1380	1300	1222	1159	1111	1071	1037	1006	995	
	5	1746	1726	1733	1722	1738	1723	1721	1730	1731	1715	1735	1716	1521	1382	1298	1218	1156	1107	1065	1033	1004	991	
	6	1743	1730	1733	1729	1734	1736	1734	1731	1724	1724	1735	1717	1536	1397	1310	1233	1175	1120	1079	1045	1016	1005	
	7	1746	1740	1728	1738	1737	1735	1723	1718	1724	1738	1740	1728	1530	1396	1311	1236	1167	1121	1079	1042	1013	1000	
	8	1747	1666	1731	1714	1713	1715	1726	1720	1715	1711	1700	1702	1516	1383	1302	1228	1158	1118	1077	1045	1011	1003	
	9	1728	1738	1740	1652	1704	1711	1730	1724	1740	1728	1727	1535	1405	1329	1263	1198	1145	1101	1064	1028	1003	992	
42	1	1751	1731	1743	1729	1738	1741	1738	1720	1705	1647	1573	1468	1368	1308	1257	1211	1168	1137	1108	1082	0	1049	425
	2	1746	1740	1737	1731	1725	1720	1711	1728	1725	1715	1660	1597	1446	1344	1272	1214	1161	1122	1084	1055	1030	1018	
	3	1745	1736	1733	1720	1724	1729	1729	1722	1724	1732	1719	1654	1609	1412	1317	1232	1169	1128	1089	1051	1017	1013	
	4	1751	1737	1738	1734	1729	1737	1721	1734	1734	1722	1729	1646	1622	1433	1320	1241	1174	1124	1083	1049	1018	1005	
	5	1749	1729	1736	1726	1742	1727	1725	1734	1735	1718	1730	1663	1573	1430	1317	1236	1171	1119	1078	1046	1015	1002	
	6	1747	1734	1736	1732	1737	1740	1737	1734	1723	1726	1731	1666	1580	1452	1328	1251	1191	1133	1092	1058	1028	1016	
	7	1750	1744	1732	1740	1741	1739	1727	1722	1727	1742	1735	1708	1576	1450	1328	1255	1183	1134	1091	1056	1026	1013	
	8	1750	1669	1735	1718	1717	1719	1730	1723	1719	1714	1695	1654	1576	1427	1317	1246	1174	1131	1088	1056	1023	1014	
	9	1732	1742	1744	1656	1709	1715	1732	1724	1735	1696	1666	1578	1453	1334	1261	1197	1143	1100	1064	1029	1004	992	
43	1	1745	1724	1735	1721	1730	1734	1729	1715	1726	1553	1555	1463	1387	1329	1276	1234	1191	1159	1128	1101	0	1057	435
	2	1739	1733	1730	1722	1718	1712	1703	1720	1720	1722	1713	1607	1484	1381	1299	1238	1181	1138	1096	1067	1040	1028	
	3	1741	1731	1726	1715	1717	1722	1720	1715	1715	1725	1719	1713	1604	1459	1354	1257	1194	1145	1105	1064	1032	1025	
	4	1745	1731	1731	1727	1721	1730	1714	1725	1727	1714	1729	1699	1599	1464	1356	1266	1195	1140	1096	1059	1028	1017	
	5	1743	1723	1730	1719	1734	1719	1717	1725	1727	1711	1731	1720	1603	1467	1353	1263	1194	1136	1091	1057	1026	1013	
	6	1741	1726	1729	1724	1729	1732	1729	1726	1719	1719	1730	1720	1620	1485	1367	1279	1215	1152	1105	1070	1039	1027	
	7	1744	1738	1725	1734	1734	1731	1719	1714	1720	1734	1736	1728	1598	1474	1359	1276	1203	1151	1103	1065	1035	1023	
	8	1744	1664	1728	1711	1711	1712	1722	1717	1711	1708	1696	1697	1559	1431	1332	1257	1189	1145	1099	1066	1033	1026	
	9	1726	1735	1737	1649	1701	1707	1725	1720	1735	1722	1718	1566	1460	1363	1288	1229	1179	1135	1096	1062	1040	1029	
44	1	1747	1726	1736	1723	1731	1734	1730	1718	1728	1726	1637	1507	1430	1368	1310	1261	1215	1180	1146	1116	0	1077	434
	2	1741	1734	1731	1724	1719	1713	1704	1721	1721	1723	1720	1687	1549	1444	1353	1281	1216	1167	1121	1087	1057	1044	
	3	1741	1732	1728	1714	1718	1722	1721	1715	1715	1724	1720	1713	1706	1511	1407	1303	1234	1178	1135	1089	1057	1046	
	4	1747	1733	1732	1728	1722	1730	1714	1727	1725	1715	1729	1701	1709	1523	1413	1315	1235	1178	1128	1087	1050	1039	
	5	1744	1724	1730	1720	1735	1720	1718	1727	1723	1711	1730	1723	1714	1527	1410	1312	1236	1174	1124	1084	1049	1035	
	6	1742	1728	1731	1726	1731	1733	1730	1727	1720	1719	1731	1721	1719	1545	1424	1329	1258	1191	1140	1097	1062	1049	
	7	1745	1738	1726	1734	1734	1732	1720	1715	1720	1735	1736	1729	1719	1541	1424	1334	1250	1193	1140	1094	1060	1046	
	8	1745	1665	1729	1712	1711	1712	1724	1715	1712	1708	1696	1702	1718	1510	1408	1321	1240	1190	1137	1096	1056	1048	
	9	1726	1736	1738	1650	1701	1708	1725	1720	1735	1724	1725	1702	1541	1442	1363	1291	1228	1176	1128	1087	1058	1046	
45	1	1740	1717	1727	1712	1720	1724	1719	1709	1719	1720	1674	1562	1483	1421	1364	1313	1262	1222	1186	1154	0	1117	444
	2	1734	1726	1722	1715	1710	1704	1694	1711	1711	1714	1714	1698	1704	1570	1464	1380	1291	1220	1161	1123	1089	1077	
	3	1736	1724	1720	1707	1709	1713	1712	1705	1707	1715	1709	1706	1711	1673	1527	1410	1326	1237	1180	1128	1093	1081	
	4	1740	1724	1724	1719	1714	1722	1707	1713	1717	1705	1719	1693	1712	1671	1519	1415	1317	1234	1172	1124	1086	1074	
	5	1738	1717	1723	1712	1726	1712	1709	1717	1717	1703	1722	1716	1720	1689	1525	1416	1321	1234	1168	1124	1086	1071	
	6	1737	1721	1724	1719	1723	1724	1721	1718	1710	1710	1722	1713	1720	1703	1539	1432	1347	1253	1185	1136	1099	1085	
	7	1739	1732	1718	1727	1726	1723	1711	1706	1711	1725	1727	1722	1717	1687	1528	1427	1326	1247	1180	1130	1095	1081	
	8	1739	1659	1722	1704	1703	1703	1713	1708	1703	1700	1687	1697	1720	1615	1487	1395	1298	1231	1167	1125	1089	1082	
	9	1720	1728	1729	1641	1692	1698	1716	1710	1725	1714	1716	1684	1592	1493	1414	1340	1272	1213	1164	1125	1101	1091	

46	1	1743	1722	1732	1717	1726	1729	1725	1713	1724	1716	1652	1540	1451	1388	1330	1277	1228	1193	1162	1133	0	1094	433
	2	1737	1730	1727	1720	1714	1709	1699	1717	1717	1720	1718	1697	1610	1472	1376	1302	1232	1183	1137	1105	1074	1062	
	3	1739	1728	1724	1711	1713	1718	1717	1711	1712	1721	1715	1710	1710	1568	1435	1328	1256	1194	1154	1109	1078	1066	
	4	1743	1728	1729	1724	1719	1726	1710	1723	1723	1711	1725	1699	1713	1576	1437	1343	1258	1197	1149	1109	1071	1059	
	5	1741	1721	1726	1715	1731	1717	1714	1722	1723	1709	1728	1721	1718	1586	1434	1341	1261	1195	1146	1107	1071	1057	
	6	1739	1725	1727	1722	1727	1729	1726	1724	1715	1716	1727	1717	1720	1616	1448	1355	1283	1211	1160	1121	1084	1071	
	7	1741	1735	1722	1731	1731	1728	1715	1711	1715	1731	1732	1726	1719	1603	1452	1362	1275	1213	1162	1120	1084	1069	
	8	1742	1662	1725	1708	1708	1708	1719	1713	1707	1705	1693	1702	1716	1574	1442	1352	1263	1210	1161	1125	1085	1075	
	9	1723	1733	1734	1647	1698	1703	1722	1716	1731	1721	1724	1701	1615	1484	1393	1313	1246	1194	1152	1115	1087	1075	
47	1	1740	1717	1727	1714	1721	1724	1720	1708	1718	1722	1718	1693	1549	1399	1339	1290	1238	1194	1156	1125	0	1090	432
	2	1734	1726	1723	1715	1709	1704	1694	1711	1710	1714	1713	1696	1708	1597	1417	1334	1261	1198	1143	1106	1075	1063	
	3	1735	1724	1720	1706	1708	1714	1712	1705	1707	1715	1710	1704	1710	1698	1559	1365	1293	1216	1162	1112	1079	1058	
	4	1739	1723	1725	1719	1714	1722	1706	1717	1717	1706	1719	1693	1709	1713	1553	1372	1288	1215	1154	1109	1072	1062	
	5	1737	1717	1723	1712	1726	1711	1709	1717	1718	1702	1721	1715	1716	1719	1553	1367	1289	1213	1149	1107	1072	1058	
	6	1735	1721	1723	1718	1723	1724	1721	1717	1711	1710	1721	1713	1716	1718	1577	1385	1312	1231	1166	1120	1085	1072	
	7	1738	1731	1718	1725	1725	1724	1711	1705	1711	1725	1726	1722	1715	1721	1635	1401	1308	1237	1169	1118	1083	1069	
	8	1737	1657	1721	1703	1703	1703	1714	1707	1703	1599	1587	1698	1718	1706	1689	1407	1302	1238	1167	1120	1079	1072	
	9	1718	1727	1729	1642	1692	1699	1717	1710	1725	1715	1718	1701	1704	1709	1578	1357	1278	1204	1143	1099	1070	1059	
48	1	1747	1725	1733	1717	1725	1728	1723	1712	1720	1725	1725	1707	1629	1531	1460	1394	1332	1287	1245	1206	0	1157	445
	2	1741	1733	1729	1721	1715	1709	1699	1715	1715	1718	1716	1704	1718	1714	1598	1492	1395	1319	1251	1204	1159	1143	
	3	1743	1730	1726	1713	1715	1718	1716	1710	1710	1718	1712	1709	1713	1706	1709	1529	1439	1343	1272	1214	1172	1155	
	4	1746	1731	1730	1725	1719	1726	1710	1721	1720	1709	1722	1695	1714	1722	1687	1535	1428	1337	1271	1212	1162	1147	
	5	1744	1723	1729	1717	1731	1716	1713	1721	1721	1705	1722	1718	1720	1728	1702	1533	1437	1342	1269	1214	1165	1145	
	6	1743	1727	1729	1724	1727	1729	1725	1721	1713	1713	1723	1716	1721	1723	1708	1555	1468	1363	1288	1231	1183	1164	
	7	1745	1738	1725	1733	1731	1728	1715	1710	1714	1728	1728	1724	1717	1725	1715	1585	1467	1379	1298	1237	1185	1155	
	8	1744	1664	1728	1711	1708	1709	1718	1712	1705	1703	1691	1700	1721	1711	1708	1609	1463	1384	1302	1244	1186	1172	
	9	1725	1735	1735	1648	1699	1704	1721	1715	1729	1718	1722	1708	1712	1715	1709	1523	1424	1341	1270	1211	1167	1150	
49	1	1742	1719	1728	1713	1721	1724	1720	1709	1720	1720	1716	1669	1580	1498	1422	1360	1306	1265	1226	1190	0	1143	445
	2	1736	1728	1725	1717	1711	1706	1695	1712	1711	1715	1714	1700	1711	1698	1579	1445	1344	1277	1217	1175	1134	1119	
	3	1738	1726	1722	1709	1710	1714	1713	1707	1708	1715	1710	1706	1709	1695	1643	1488	1381	1295	1238	1184	1145	1129	
	4	1742	1726	1725	1721	1715	1723	1708	1718	1717	1705	1719	1693	1711	1712	1640	1498	1376	1296	1237	1182	1135	1121	
	5	1739	1718	1724	1713	1727	1712	1710	1718	1719	1703	1721	1716	1717	1719	1650	1503	1383	1300	1234	1183	1136	1118	
	6	1738	1723	1724	1720	1723	1725	1722	1713	1711	1711	1722	1713	1719	1717	1658	1527	1410	1317	1251	1199	1153	1135	
	7	1740	1733	1721	1728	1727	1724	1712	1707	1711	1726	1726	1722	1717	1716	1658	1545	1406	1324	1255	1199	1152	1134	
	8	1740	1659	1724	1706	1704	1704	1715	1703	1703	1701	1688	1698	1717	1703	1648	1530	1391	1320	1252	1201	1150	1137	
	9	1721	1730	1731	1643	1694	1700	1717	1711	1725	1715	1718	1700	1680	1655	1555	1441	1352	1286	1230	1181	1146	1132	
50	1	1809	1786	1801	1780	1789	1648	1533	1454	1361	1284	1225	1175	1134	1102	1069	1044	1017	995	974	954	0	929	374
	2	1801	1795	1787	1613	1507	1327	1206	1154	1105	1063	1022	986	956	928	905	885	868	852	837	825	815	810	
	3	1805	1792	1787	1765	1591	1492	1320	1211	1140	1097	1052	1014	982	948	928	904	887	873	856	839	827	828	
	4	1810	1794	1790	1787	1674	1531	1404	1276	1192	1125	1078	1030	996	968	941	917	894	876	860	846	834	829	
	5	1807	1788	1800	1785	1800	1775	1662	1542	1442	1298	1221	1154	1102	1060	1022	990	963	940	917	899	882	875	
	6	1806	1793	1797	1791	1766	1798	1793	1534	1544	1378	1256	1186	1124	1076	1033	1001	976	948	926	906	888	879	
	7	1809	1805	1791	1803	1801	1800	1783	1645	1551	1403	1274	1188	1118	1071	1029	997	967	943	919	898	881	866	
	8	1811	1725	1798	1780	1777	1776	1789	1524	1525	1383	1256	1179	1124	1071	1030	996	965	944	919	900	881	875	
	9	1789	1804	1806	1712	1768	1772	1786	1587	1454	1331	1226	1155	1102	1057	1022	990	963	937	914	893	877	868	

TABLE IV. - Continued. RADIATOR TUBE SURFACE TEMPERATURES

(a) Continued. U. S. Customary Units

RUN	TUBE	DISTANCE FROM TUBE INLET TO THERMOCOUPLE, IN.																			O-R			
		2	10	18	26	34	42	50	58	65	74	82	90	98	106	114	122	130	138	146		154	162	170
TEMPERATURES, DEGREES RANKINE																								
51	1	1807	1786	1803	1784	1798	1799	1788	1629	1435	1351	1287	1228	1177	1137	1097	1066	1037	1013	991	969	0	943	375
	2	1801	1799	1796	1790	1784	1770	1600	1395	1305	1238	1176	1122	1081	1046	1013	988	961	941	920	904	889	883	
	3	1804	1794	1791	1777	1787	1785	1782	1470	1352	1273	1201	1146	1099	1055	1027	992	967	948	927	906	886	890	
	4	1809	1794	1792	1794	1797	1798	1779	1770	1462	1346	1264	1186	1130	1081	1037	1006	974	947	925	907	890	883	
	5	1806	1786	1797	1786	1803	1786	1786	1794	1793	1494	1358	1257	1182	1123	1071	1027	993	964	938	919	900	892	
	6	1805	1790	1796	1792	1799	1801	1799	1794	1794	1785	1506	1390	1282	1204	1142	1087	1044	1011	976	951	930	910	901
	7	1808	1803	1789	1803	1803	1801	1787	1780	1787	1503	1380	1281	1199	1140	1087	1045	1007	979	952	929	910	893	
	8	1809	1724	1796	1778	1779	1779	1794	1778	1773	1528	1342	1261	1199	1136	1087	1045	1009	986	956	935	913	906	
	9	1737	1802	1804	1710	1766	1773	1794	1779	1594	1396	1299	1230	1171	1120	1080	1044	1016	990	965	939	920	908	
52	1	1810	1790	1806	1787	1801	1803	1795	1758	1545	1436	1343	1264	1203	1158	1115	1081	1050	1025	1000	978	0	949	375
	2	1804	1801	1799	1792	1787	1779	1692	1487	1359	1253	1191	1131	1088	1053	1019	991	965	943	921	905	889	883	
	3	1806	1796	1793	1779	1789	1791	1792	1715	1491	1361	1258	1190	1135	1086	1055	1016	989	969	946	921	903	903	
	4	1812	1797	1793	1797	1799	1802	1783	1790	1634	1467	1339	1234	1166	1108	1062	1028	993	963	939	919	898	892	
	5	1809	1789	1800	1788	1805	1789	1787	1797	1801	1598	1473	1335	1239	1167	1109	1062	1026	993	963	941	920	910	
	6	1807	1793	1798	1794	1801	1804	1802	1797	1792	1745	1505	1363	1262	1190	1127	1081	1044	1006	978	953	931	921	
	7	1810	1805	1791	1805	1805	1805	1790	1782	1792	1757	1494	1362	1256	1187	1127	1081	1040	1009	978	951	931	912	
	8	1811	1726	1796	1780	1780	1781	1796	1783	1783	1730	1467	1344	1258	1184	1127	1081	1039	1012	981	956	932	925	
	9	1790	1804	1806	1712	1768	1776	1798	1790	1788	1599	1409	1295	1220	1162	1113	1072	1039	1008	980	954	934	923	
53	1	1815	1795	1810	1785	1792	1790	1758	1669	1531	1415	1343	1281	1228	1185	1141	1108	1076	1052	1028	1006	0	979	395
	2	1811	1806	1804	1794	1782	1771	1757	1711	1581	1427	1339	1269	1215	1164	1117	1083	1050	1025	998	978	960	952	
	3	1812	1800	1798	1783	1791	1787	1779	1733	1630	1442	1334	1259	1198	1140	1100	1057	1026	1006	982	956	932	935	
	4	1818	1802	1797	1801	1795	1799	1767	1744	1535	1443	1342	1257	1194	1133	1086	1052	1019	989	965	945	925	919	
	5	1816	1795	1804	1793	1811	1790	1779	1767	1693	1477	1360	1276	1202	1141	1090	1051	1021	991	964	944	924	917	
	6	1813	1800	1804	1800	1806	1808	1797	1777	1719	1560	1396	1300	1223	1158	1102	1064	1034	1000	974	952	933	924	
	7	1817	1812	1797	1809	1809	1807	1786	1755	1714	1578	1393	1304	1221	1159	1104	1064	1028	1000	973	948	930	919	
	8	1818	1733	1803	1786	1786	1779	1785	1748	1689	1538	1369	1294	1232	1164	1112	1071	1034	1010	981	960	938	933	
	9	1795	1809	1811	1714	1766	1764	1778	1725	1632	1473	1365	1290	1228	1174	1126	1088	1056	1027	1000	975	959	948	
54	1	1818	1798	1812	1794	1809	1811	1807	1756	1565	1420	1327	1252	1192	1147	1103	1069	1037	1011	987	965	0	937	395
	2	1812	1808	1806	1798	1792	1788	1781	1737	1593	1433	1333	1252	1195	1146	1101	1066	1031	1005	979	958	939	929	
	3	1814	1802	1800	1786	1797	1799	1800	1785	1659	1463	1346	1254	1190	1135	1095	1050	1016	996	970	943	916	917	
	4	1820	1805	1799	1803	1798	1809	1791	1800	1784	1492	1365	1254	1184	1123	1072	1033	995	962	934	912	891	883	
	5	1818	1798	1806	1796	1813	1796	1796	1804	1808	1596	1419	1302	1215	1148	1092	1045	1008	975	943	920	898	889	
	6	1815	1801	1805	1801	1808	1811	1809	1803	1799	1657	1454	1327	1237	1168	1109	1063	1028	990	960	934	913	902	
	7	1818	1814	1799	1812	1811	1810	1796	1790	1799	1691	1449	1325	1229	1165	1108	1063	1022	991	961	933	912	895	
	8	1819	1735	1805	1788	1787	1789	1802	1792	1791	1700	1431	1310	1233	1162	1107	1061	1020	994	964	940	914	907	
	9	1797	1811	1813	1720	1776	1783	1804	1795	1798	1595	1383	1276	1203	1143	1095	1054	1020	990	965	939	920	907	
55	1	1815	1795	1810	1792	1806	1809	1806	1775	1589	1443	1334	1250	1187	1139	1094	1060	1028	1003	979	958	0	930	398
	2	1810	1806	1803	1796	1789	1786	1779	1735	1610	1451	1335	1247	1188	1137	1092	1058	1024	999	974	954	935	925	
	3	1812	1800	1797	1784	1793	1797	1797	1777	1587	1411	1288	1207	1148	1096	1062	1022	993	973	950	926	904	906	
	4	1818	1803	1798	1802	1798	1806	1789	1793	1581	1393	1267	1174	1115	1066	1025	993	963	936	915	898	881	874	
	5	1815	1794	1803	1793	1810	1793	1793	1801	1805	1543	1441	1300	1209	1142	1087	1043	1009	979	952	931	911	903	
	6	1814	1799	1803	1800	1806	1809	1807	1801	1797	1697	1481	1300	1234	1165	1107	1063	1029	994	967	944	924	914	
	7	1816	1812	1797	1809	1809	1808	1795	1788	1795	1714	1477	1333	1230	1164	1107	1064	1024	995	967	941	923	908	
	8	1817	1733	1803	1786	1785	1787	1800	1789	1788	1696	1475	1333	1244	1167	1111	1065	1023	997	967	945	921	915	
	9	1795	1808	1811	1717	1773	1781	1803	1794	1805	1533	1435	1303	1216	1151	1099	1056	1021	990	963	937	920	908	

56	1	1815	1795	1810	1792	1805	1808	1805	1781	1614	1460	1360	1275	1211	1166	1122	1087	1054	1027	1001	979	0	950	397
	2	1810	1805	1803	1796	1791	1785	1778	1791	1652	1476	1367	1276	1215	1166	1121	1086	1050	1022	995	974	954	945	
	3	1812	1801	1797	1783	1794	1796	1797	1784	1733	1512	1380	1274	1206	1151	1112	1067	1030	1011	984	957	932	933	
	4	1818	1803	1797	1802	1797	1807	1788	1798	1801	1533	1395	1270	1199	1140	1089	1050	1013	982	954	933	912	905	
	5	1815	1794	1804	1792	1809	1793	1792	1801	1805	1598	1472	1337	1241	1175	1119	1072	1035	1002	972	949	927	918	
	6	1814	1799	1802	1799	1806	1808	1807	1801	1795	1749	1510	1367	1265	1195	1136	1091	1055	1016	987	963	941	930	
	7	1816	1811	1797	1810	1809	1809	1795	1789	1797	1772	1507	1370	1261	1194	1138	1093	1050	1018	987	961	939	924	
	8	1817	1733	1802	1785	1785	1786	1800	1788	1787	1752	1487	1362	1271	1194	1139	1093	1049	1020	988	963	939	931	
	9	1796	1809	1811	1717	1773	1781	1802	1794	1803	1545	1439	1324	1237	1176	1126	1083	1045	1013	984	956	936	925	
57	1	1816	1796	1810	1791	1805	1806	1796	1733	1690	1586	1481	1403	1345	1300	1252	1215	1177	1149	1121	1095	0	1052	397
	2	1811	1806	1802	1796	1789	1785	1777	1783	1749	1655	1540	1424	1361	1302	1246	1202	1158	1124	1089	1063	1039	1030	
	3	1811	1800	1796	1782	1792	1795	1795	1783	1780	1762	1671	1497	1385	1309	1254	1188	1141	1108	1076	1042	1014	1013	
	4	1816	1802	1798	1801	1799	1806	1787	1797	1801	1772	1742	1557	1424	1335	1265	1200	1147	1104	1066	1035	1009	1001	
	5	1814	1794	1803	1791	1809	1792	1790	1801	1804	1777	1721	1583	1428	1342	1266	1198	1147	1101	1063	1033	1006	997	
	6	1814	1799	1803	1799	1805	1808	1806	1801	1795	1788	1736	1609	1447	1358	1281	1215	1166	1115	1076	1044	1018	1007	
	7	1816	1811	1796	1808	1809	1807	1793	1787	1795	1800	1721	1579	1424	1347	1275	1214	1158	1116	1076	1041	1017	1004	
	8	1817	1731	1802	1784	1784	1784	1799	1784	1779	1739	1643	1485	1395	1321	1259	1202	1151	1119	1080	1052	1021	1015	
	9	1796	1809	1811	1716	1772	1778	1798	1783	1723	1555	1517	1411	1347	1296	1247	1203	1165	1129	1097	1066	1046	1035	
58	1	1814	1793	1807	1789	1803	1803	1795	1764	1675	1624	1525	1443	1373	1315	1263	1222	1181	1150	1119	1092	0	1059	395
	2	1808	1805	1801	1795	1787	1734	1775	1783	1753	1718	1594	1479	1400	1323	1257	1208	1161	1125	1089	1062	1038	1029	
	3	1811	1798	1796	1782	1792	1795	1795	1782	1779	1764	1685	1549	1448	1343	1270	1198	1151	1115	1082	1048	1020	1017	
	4	1815	1801	1796	1800	1797	1805	1785	1795	1799	1776	1562	1574	1482	1371	1285	1217	1162	1116	1076	1043	1015	1007	
	5	1813	1793	1803	1790	1807	1791	1790	1799	1800	1773	1598	1621	1485	1373	1284	1215	1161	1113	1073	1043	1015	1004	
	6	1811	1797	1800	1797	1804	1806	1805	1799	1792	1784	1731	1651	1505	1398	1300	1230	1180	1126	1086	1053	1026	1015	
	7	1815	1810	1795	1808	1807	1806	1792	1786	1794	1800	1730	1636	1485	1386	1296	1230	1171	1127	1085	1050	1025	1011	
	8	1815	1731	1801	1784	1784	1784	1798	1783	1784	1756	1673	1551	1458	1359	1282	1222	1166	1128	1086	1056	1026	1020	
	9	1794	1807	1809	1714	1770	1776	1795	1784	1770	1739	1588	1482	1396	1326	1267	1218	1174	1134	1098	1064	1041	1031	
59	1	1813	1792	1807	1788	1802	1805	1798	1772	1715	1577	1487	1410	1343	1291	1243	1205	1167	1139	1112	1085	0	1054	395
	2	1808	1803	1801	1794	1786	1783	1775	1787	1775	1705	1542	1436	1360	1291	1234	1190	1148	1116	1082	1057	1032	1023	
	3	1810	1795	1795	1781	1791	1794	1794	1783	1782	1775	1546	1499	1398	1308	1246	1180	1135	1105	1074	1040	1011	1009	
	4	1815	1795	1796	1799	1798	1804	1784	1795	1800	1783	1754	1530	1435	1336	1260	1194	1143	1102	1066	1035	1007	998	
	5	1812	1792	1801	1789	1807	1790	1789	1799	1802	1778	1753	1555	1440	1341	1260	1192	1142	1098	1061	1032	1004	994	
	6	1811	1796	1800	1796	1802	1806	1804	1799	1794	1790	1774	1579	1459	1360	1273	1208	1160	1112	1074	1042	1016	1004	
	7	1813	1809	1793	1806	1807	1804	1791	1785	1793	1805	1768	1567	1440	1346	1267	1207	1152	1112	1073	1039	1014	1000	
	8	1815	1729	1801	1782	1783	1783	1797	1784	1785	1769	1534	1498	1413	1320	1252	1195	1145	1112	1074	1047	1017	1012	
	9	1793	1807	1809	1715	1771	1777	1798	1785	1785	1581	1533	1438	1360	1297	1240	1194	1154	1119	1086	1056	1034	1023	
60	1	1811	1791	1806	1787	1802	1804	1800	1785	1798	1793	1638	1479	1370	1305	1243	1194	1146	1110	1079	1049	0	1014	394
	2	1807	1801	1798	1792	1785	1781	1772	1791	1791	1784	1660	1485	1377	1305	1243	1191	1142	1105	1069	1042	1017	1007	
	3	1809	1797	1794	1779	1789	1792	1791	1782	1783	1789	1749	1534	1392	1309	1254	1188	1139	1106	1073	1039	1010	1008	
	4	1813	1798	1793	1796	1791	1802	1783	1795	1799	1783	1793	1626	1453	1343	1275	1210	1154	1109	1070	1038	1011	1000	
	5	1811	1790	1799	1788	1805	1789	1787	1798	1799	1779	1797	1647	1456	1348	1276	1208	1154	1107	1068	1038	1010	998	
	6	1810	1796	1799	1796	1801	1804	1802	1797	1792	1789	1800	1700	1491	1370	1290	1225	1174	1121	1082	1050	1022	1010	
	7	1812	1807	1792	1805	1804	1803	1789	1784	1791	1806	1804	1728	1498	1376	1298	1234	1171	1126	1084	1047	1021	1004	
	8	1813	1729	1799	1781	1780	1782	1795	1785	1782	1778	1763	1761	1555	1396	1314	1245	1177	1134	1089	1056	1021	1014	
	9	1791	1805	1807	1713	1769	1777	1797	1791	1805	1793	1793	1701	1495	1378	1303	1238	1177	1126	1083	1046	1020	1006	

TABLE IV. - Continued. RADIATOR TUBE SURFACE TEMPERATURES

(a) Continued. U. S. Customary Units

RUN	TUBE	DISTANCE FROM TUBE INLET TO THERMOCOUPLE, IN.																		O-R				
		2	10	18	26	34	42	50	58	56	74	82	90	98	106	114	122	130	138		146	154	162	170
		TEMPERATURES, DEGREES RANKINE																						
61	1	1815	1794	1808	1789	1803	1806	1800	1779	1738	1653	1590	1487	1412	1350	1290	1246	1205	1175	1146	1118	0	1083	390
	2	1809	1804	1802	1795	1787	1784	1776	1791	1785	1740	1735	1547	1453	1372	1296	1243	1197	1164	1125	1098	1070	1051	
	3	1810	1799	1795	1782	1792	1794	1794	1784	1785	1789	1755	1703	1536	1418	1335	1247	1200	1159	1126	1088	1057	1051	
	4	1816	1800	1797	1799	1796	1805	1785	1797	1801	1787	1796	1649	1587	1451	1357	1270	1208	1163	1122	1085	1054	1042	
	5	1814	1793	1802	1790	1807	1791	1789	1800	1801	1781	1797	1661	1588	1452	1352	1266	1207	1159	1117	1084	1052	1039	
	6	1812	1798	1801	1798	1804	1806	1804	1799	1794	1791	1797	1671	1605	1468	1365	1280	1225	1173	1132	1096	1065	1052	
	7	1814	1810	1795	1807	1807	1805	1791	1786	1793	1807	1799	1666	1588	1459	1360	1279	1216	1175	1131	1092	1063	1051	
	8	1816	1731	1801	1783	1783	1783	1797	1785	1785	1775	1696	1630	1553	1432	1343	1267	1207	1174	1131	1099	1063	1058	
	9	1795	1808	1809	1715	1770	1778	1799	1789	1802	1746	1644	1580	1466	1387	1313	1253	1207	1169	1132	1097	1073	1060	
62	1	1816	1794	1808	1788	1801	1805	1799	1787	1797	1782	1725	1635	1543	1473	1407	1353	1301	1264	1230	1199	0	1165	388
	2	1811	1805	1802	1795	1786	1783	1774	1793	1792	1795	1791	1752	1706	1597	1484	1391	1315	1262	1212	1178	1144	1132	
	3	1812	1800	1796	1782	1791	1793	1793	1783	1783	1795	1790	1784	1777	1704	1585	1442	1354	1276	1225	1179	1145	1134	
	4	1817	1802	1797	1800	1797	1805	1785	1795	1799	1786	1799	1773	1782	1717	1584	1460	1355	1279	1227	1181	1143	1130	
	5	1816	1794	1803	1790	1807	1791	1788	1798	1799	1781	1802	1793	1784	1720	1577	1449	1354	1279	1223	1181	1142	1126	
	6	1814	1800	1802	1798	1803	1806	1803	1799	1792	1791	1802	1793	1788	1735	1595	1470	1379	1294	1237	1193	1156	1142	
	7	1817	1811	1796	1807	1807	1805	1790	1785	1792	1807	1808	1803	1784	1723	1582	1465	1360	1291	1233	1186	1152	1139	
	8	1817	1732	1801	1783	1782	1783	1796	1783	1784	1780	1767	1772	1778	1649	1538	1426	1332	1277	1223	1187	1150	1144	
	9	1796	1808	1810	1715	1770	1778	1798	1791	1804	1791	1789	1724	1641	1558	1459	1373	1313	1263	1218	1181	1158	1147	
63	1	1815	1793	1809	1790	1803	1806	1799	1788	1801	1803	1799	1715	1600	1491	1407	1333	1265	1215	1172	1137	0	1097	384
	2	1810	1804	1802	1795	1787	1784	1774	1793	1793	1797	1796	1760	1661	1520	1427	1347	1276	1222	1172	1137	1105	1094	
	3	1811	1799	1796	1782	1789	1793	1793	1783	1785	1795	1791	1783	1776	1565	1464	1360	1293	1228	1185	1139	1106	1098	
	4	1817	1801	1797	1800	1798	1805	1784	1795	1799	1787	1800	1773	1794	1657	1513	1409	1318	1246	1193	1145	1109	1098	
	5	1814	1793	1802	1790	1807	1791	1788	1799	1800	1781	1803	1795	1795	1657	1510	1403	1317	1245	1189	1145	1109	1095	
	6	1813	1798	1802	1798	1804	1806	1804	1800	1792	1792	1803	1793	1801	1703	1531	1426	1345	1264	1206	1160	1123	1109	
	7	1815	1810	1795	1807	1807	1805	1791	1785	1793	1809	1809	1804	1798	1748	1549	1444	1348	1277	1213	1161	1125	1113	
	8	1816	1731	1801	1783	1783	1783	1797	1785	1784	1780	1768	1779	1799	1735	1585	1460	1360	1291	1221	1173	1127	1120	
	9	1795	1809	1810	1716	1771	1779	1799	1793	1807	1798	1801	1787	1787	1686	1531	1431	1342	1264	1199	1148	1115	1100	
64	1	1803	1781	1795	1776	1790	1792	1787	1775	1785	1787	1761	1731	1628	1514	1422	1351	1290	1246	1205	1166	0	1118	391
	2	1798	1793	1788	1782	1774	1771	1761	1780	1779	1782	1778	1733	1703	1577	1464	1375	1302	1250	1198	1158	1121	1108	
	3	1799	1788	1784	1770	1778	1782	1780	1770	1772	1783	1777	1770	1734	1661	1524	1397	1322	1254	1208	1160	1124	1113	
	4	1805	1789	1784	1787	1782	1791	1772	1784	1785	1774	1787	1760	1763	1709	1562	1437	1339	1270	1219	1168	1127	1114	
	5	1802	1781	1790	1778	1795	1779	1776	1785	1787	1768	1789	1780	1764	1713	1560	1429	1340	1271	1216	1169	1126	1110	
	6	1800	1787	1789	1785	1790	1792	1791	1785	1779	1778	1790	1780	1777	1726	1584	1456	1367	1288	1232	1184	1142	1125	
	7	1803	1796	1783	1795	1794	1792	1778	1773	1779	1795	1796	1790	1775	1736	1606	1477	1369	1299	1238	1184	1143	1128	
	8	1804	1720	1788	1771	1770	1771	1783	1772	1771	1767	1754	1765	1779	1734	1640	1496	1378	1310	1244	1195	1146	1135	
	9	1782	1796	1797	1704	1758	1766	1786	1780	1795	1734	1786	1767	1738	1652	1581	1459	1360	1285	1224	1170	1134	1115	
65	1	1818	1796	1810	1791	1804	1808	1799	1790	1801	1804	1803	1776	1621	1522	1445	1381	1316	1264	1215	1175	0	1130	383
	2	1813	1808	1804	1798	1789	1786	1776	1795	1794	1798	1797	1777	1749	1600	1491	1406	1330	1268	1211	1172	1137	1125	
	3	1814	1803	1799	1785	1792	1796	1797	1785	1787	1797	1794	1788	1792	1712	1573	1439	1361	1281	1227	1178	1143	1133	
	4	1820	1804	1800	1802	1800	1806	1786	1798	1801	1788	1801	1776	1798	1761	1602	1478	1380	1299	1239	1185	1144	1132	
	5	1817	1796	1805	1793	1810	1793	1791	1801	1803	1784	1804	1797	1798	1760	1597	1471	1381	1301	1235	1185	1144	1128	
	6	1815	1801	1804	1800	1805	1808	1806	1801	1794	1794	1805	1795	1803	1792	1619	1493	1408	1320	1252	1199	1158	1143	
	7	1818	1813	1798	1810	1809	1807	1793	1787	1794	1810	1811	1806	1799	1798	1641	1513	1411	1334	1260	1200	1160	1145	
	8	1819	1734	1804	1786	1786	1786	1799	1787	1787	1782	1769	1782	1801	1787	1668	1522	1414	1345	1267	1211	1161	1153	
	9	1798	1811	1813	1718	1772	1781	1801	1795	1809	1800	1803	1788	1790	1786	1602	1480	1389	1309	1237	1182	1148	1134	

66	1	1811	1788	1801	1781	1793	1797	1789	1780	1791	1796	1796	1754	1660	1581	1486	1412	1351	1311	1279	1247	0	1210	377
	2	1804	1799	1795	1787	1779	1775	1765	1785	1784	1788	1785	1771	1784	1752	1629	1516	1411	1336	1275	1236	1197	1183	
	3	1806	1794	1789	1775	1782	1786	1786	1773	1777	1789	1783	1779	1782	1772	1724	1577	1466	1365	1291	1239	1202	1182	
	4	1811	1795	1790	1793	1792	1796	1776	1789	1791	1778	1791	1767	1787	1789	1724	1605	1466	1364	1302	1249	1210	1199	
	5	1810	1788	1798	1785	1801	1785	1781	1791	1791	1773	1794	1788	1788	1796	1725	1602	1470	1368	1298	1253	1211	1195	
	6	1808	1793	1796	1791	1797	1799	1795	1791	1784	1783	1795	1786	1793	1794	1733	1615	1504	1386	1313	1266	1227	1212	
	7	1810	1804	1789	1801	1799	1798	1783	1777	1784	1821	1830	1797	1790	1795	1742	1624	1490	1388	1314	1263	1228	1213	
	8	1811	1726	1795	1777	1776	1776	1790	1773	1775	1775	1760	1772	1790	1777	1731	1600	1456	1373	1305	1266	1228	1225	
	9	1790	1803	1803	1708	1763	1771	1791	1785	1797	1788	1791	1775	1772	1728	1620	1499	1405	1338	1285	1247	1225	1214	
67	1	1813	1792	1807	1788	1800	1803	1795	1786	1797	1800	1799	1789	1788	1684	1531	1418	1324	1261	1211	1168	0	1123	392
	2	1808	1803	1800	1793	1785	1781	1772	1791	1789	1794	1792	1777	1795	1714	1552	1435	1341	1275	1217	1178	1141	1130	
	3	1810	1799	1794	1780	1788	1791	1792	1780	1782	1792	1789	1783	1788	1762	1612	1462	1368	1284	1231	1183	1149	1137	
	4	1814	1800	1795	1798	1796	1802	1782	1794	1795	1785	1797	1772	1792	1795	1711	1538	1406	1308	1245	1189	1148	1136	
	5	1812	1792	1801	1789	1805	1788	1786	1796	1797	1778	1799	1794	1792	1802	1721	1535	1409	1312	1241	1191	1149	1134	
	6	1811	1797	1800	1795	1801	1804	1801	1795	1789	1789	1800	1791	1797	1798	1766	1569	1447	1336	1261	1207	1165	1149	
	7	1813	1808	1793	1806	1805	1804	1788	1783	1789	1806	1806	1802	1794	1801	1783	1599	1455	1355	1274	1211	1168	1153	
	8	1815	1730	1800	1782	1781	1782	1794	1783	1782	1778	1765	1778	1795	1787	1784	1651	1484	1382	1289	1226	1171	1151	
	9	1793	1807	1808	1714	1769	1777	1796	1791	1803	1795	1795	1784	1785	1791	1775	1588	1451	1343	1258	1194	1154	1135	
68	1	1813	1790	1804	1784	1796	1800	1792	1783	1794	1798	1792	1726	1664	1582	1508	1449	1386	1336	1290	1248	0	1202	379
	2	1807	1801	1798	1791	1783	1779	1768	1788	1787	1790	1789	1772	1780	1746	1615	1515	1431	1362	1294	1248	1204	1191	
	3	1809	1797	1793	1778	1784	1788	1788	1775	1779	1791	1785	1780	1784	1768	1730	1562	1475	1392	1315	1255	1217	1195	
	4	1813	1798	1793	1795	1795	1799	1780	1792	1793	1782	1795	1769	1788	1785	1733	1594	1482	1393	1325	1260	1213	1200	
	5	1812	1790	1800	1787	1803	1787	1784	1794	1795	1775	1797	1791	1790	1790	1738	1588	1485	1399	1322	1264	1214	1197	
	6	1810	1795	1798	1794	1799	1802	1799	1794	1787	1786	1797	1788	1793	1788	1713	1611	1513	1416	1339	1279	1230	1212	
	7	1813	1807	1791	1804	1803	1800	1786	1780	1787	1803	1803	1798	1792	1790	1725	1623	1508	1428	1347	1278	1231	1213	
	8	1814	1728	1798	1780	1778	1778	1792	1780	1778	1775	1762	1775	1792	1777	1762	1602	1494	1429	1345	1285	1230	1221	
	9	1793	1805	1805	1712	1766	1773	1793	1788	1799	1792	1793	1778	1776	1766	1648	1546	1466	1389	1319	1261	1223	1207	
69	1	1811	1789	1803	1782	1796	1798	1790	1781	1793	1796	1795	1781	1759	1666	1565	1461	1380	1321	1268	1220	0	1166	393
	2	1805	1800	1796	1790	1781	1778	1768	1787	1785	1790	1788	1772	1788	1753	1643	1504	1403	1334	1269	1222	1179	1155	
	3	1807	1795	1791	1777	1784	1787	1788	1775	1778	1789	1785	1780	1783	1772	1720	1555	1443	1356	1286	1229	1190	1171	
	4	1812	1796	1792	1795	1794	1798	1779	1791	1792	1780	1793	1769	1788	1792	1744	1620	1472	1372	1306	1240	1192	1178	
	5	1811	1789	1798	1785	1801	1785	1783	1793	1794	1775	1796	1790	1790	1796	1745	1614	1478	1379	1303	1245	1194	1175	
	6	1809	1794	1796	1793	1798	1801	1797	1792	1785	1784	1796	1787	1793	1794	1764	1645	1518	1400	1323	1261	1211	1192	
	7	1811	1805	1790	1803	1801	1799	1784	1778	1785	1802	1802	1798	1790	1797	1783	1681	1529	1421	1336	1265	1215	1195	
	8	1812	1727	1797	1778	1778	1777	1790	1779	1777	1773	1761	1773	1790	1782	1779	1691	1548	1440	1346	1279	1219	1205	
	9	1791	1803	1804	1710	1765	1772	1792	1787	1799	1791	1795	1777	1780	1785	1767	1632	1502	1395	1313	1246	1201	1181	
70	1	1809	1785	1799	1780	1791	1795	1786	1777	1788	1793	1793	1774	1733	1638	1567	1479	1396	1335	1280	1237	0	1193	379
	2	1802	1798	1793	1787	1778	1774	1765	1784	1782	1785	1784	1770	1787	1779	1703	1586	1468	1379	1299	1246	1202	1189	
	3	1804	1793	1789	1774	1781	1784	1785	1772	1775	1786	1780	1777	1779	1774	1779	1634	1531	1425	1329	1259	1218	1194	
	4	1810	1794	1790	1792	1791	1794	1775	1787	1789	1777	1789	1765	1784	1789	1774	1658	1541	1423	1339	1263	1212	1200	
	5	1808	1786	1795	1783	1798	1781	1779	1788	1789	1770	1791	1787	1785	1795	1778	1650	1546	1429	1336	1266	1214	1197	
	6	1806	1790	1793	1788	1794	1796	1793	1788	1782	1791	1792	1783	1789	1791	1777	1684	1584	1451	1356	1283	1229	1210	
	7	1809	1803	1788	1800	1798	1797	1782	1775	1782	1798	1799	1795	1787	1794	1783	1708	1597	1473	1366	1281	1228	1210	
	8	1809	1724	1794	1776	1775	1775	1787	1775	1774	1770	1757	1770	1787	1780	1775	1716	1606	1485	1365	1283	1222	1212	
	9	1789	1801	1802	1708	1762	1770	1789	1783	1795	1787	1790	1776	1778	1781	1753	1651	1543	1415	1312	1239	1200	1187	

TABLE IV. - Continued. RADIATOR TUBE SURFACE TEMPERATURES

(a) Concluded. U. S. Customary Units

RUN	TUBE	DISTANCE FROM TUBE INLET TO THERMOCOUPLE, IN.																			O-R			
		2	10	18	26	34	42	50	58	66	74	82	90	98	106	114	122	130	138	146		154	162	170
		TEMPERATURES, DEGREES RANKINE																						
71	1	1809	1787	1801	1782	1795	1798	1790	1780	1792	1793	1792	1758	1656	1582	1547	1513	1417	1321	1258	1211	0	1166	381
	2	1805	1798	1795	1788	1780	1776	1767	1787	1785	1789	1787	1768	1773	1682	1588	1553	1431	1336	1260	1212	1174	1164	
	3	1805	1793	1789	1775	1782	1786	1786	1775	1777	1788	1782	1777	1780	1746	1634	1595	1476	1365	1280	1219	1183	1173	
	4	1810	1795	1790	1793	1791	1797	1777	1789	1791	1779	1792	1767	1788	1776	1659	1582	1519	1393	1303	1231	1185	1175	
	5	1809	1787	1796	1785	1800	1784	1782	1791	1793	1774	1795	1789	1788	1781	1663	1577	1527	1399	1300	1233	1186	1174	
	6	1807	1792	1796	1791	1797	1799	1796	1791	1785	1784	1795	1786	1792	1786	1688	1577	1573	1429	1323	1249	1201	1187	
	7	1809	1804	1789	1800	1800	1798	1783	1778	1785	1801	1801	1797	1790	1789	1684	1590	1584	1456	1340	1254	1205	1191	
	8	1809	1724	1795	1776	1776	1776	1789	1777	1775	1772	1760	1772	1788	1769	1691	1580	1531	1489	1364	1272	1207	1199	
	9	1789	1803	1803	1709	1763	1771	1791	1785	1798	1790	1792	1772	1770	1742	1625	1568	1565	1438	1318	1237	1192	1178	
72	1	1815	1796	1810	1792	1806	1809	1806	1782	1587	1445	1340	1253	1186	1137	1091	1055	1022	995	970	947	0	918	399
	2	1811	1807	1803	1797	1791	1786	1778	1737	1583	1438	1332	1243	1184	1133	1088	1054	1019	994	966	945	927	915	
	3	1813	1795	1796	1781	1793	1792	1791	1521	1382	1276	1192	1134	1087	1042	1015	981	957	938	916	893	873	873	
	4	1820	1276	1076	1043	1034	1029	1032	1039	977	924	881	843	822	808	799	782	770	762	755	748	745	754	
	5	1816	1794	1803	1793	1809	1793	1792	1799	1802	1557	1397	1277	1192	1131	1081	1038	1005	975	947	926	905	895	
	6	1814	1800	1803	1800	1806	1809	1807	1801	1797	1584	1469	1330	1234	1165	1107	1064	1031	994	966	942	920	910	
	7	1816	1812	1797	1810	1811	1809	1796	1788	1797	1734	1469	1336	1233	1167	1111	1066	1026	996	967	939	919	903	
	8	1818	1734	1803	1786	1786	1787	1800	1790	1789	1749	1478	1347	1256	1174	1117	1070	1028	1000	967	943	918	911	
	9	1796	1810	1811	1718	1774	1782	1803	1795	1813	1725	1473	1341	1241	1167	1111	1066	1027	993	963	935	915	902	
73	1	1800	1779	1793	1776	1789	1792	1787	1775	1785	1786	1694	1527	1395	1332	1280	1233	1183	1144	1110	1080	0	1047	400
	2	1796	1790	1787	1780	1773	1770	1758	1775	1775	1775	1705	1515	1397	1331	1277	1227	1172	1131	1091	1064	1041	1032	
	3	1801	1791	1787	1773	1781	1779	1669	1260	1143	1070	988	944	923	899	885	867	852	837	819	803	797	793	
	4	1806	1792	1787	1790	1786	1788	1633	1419	1197	1074	975	928	904	889	872	844	819	797	777	758	744	739	
	5	1800	1779	1787	1776	1793	1777	1775	1784	1785	1766	1787	1770	1570	1393	1326	1268	1199	1135	1086	1056	1031	1022	
	6	1798	1783	1787	1782	1788	1791	1789	1784	1778	1777	1790	1775	1632	1440	1353	1297	1235	1163	1112	1075	1051	1041	
	7	1801	1795	1781	1793	1793	1790	1777	1772	1778	1794	1796	1786	1640	1448	1356	1301	1228	1166	1113	1074	1050	1038	
	8	1802	1718	1786	1770	1768	1769	1782	1773	1770	1766	1754	1763	1700	1459	1360	1297	1225	1170	1115	1080	1048	1045	
	9	1780	1793	1795	1702	1758	1765	1785	1779	1795	1784	1787	1764	1611	1411	1329	1270	1208	1150	1103	1065	1042	1032	
74	1	1747	1725	1736	1719	1729	1732	1727	1715	1724	1729	1727	1717	1668	1544	1452	1379	1310	1255	1206	1164	0	1117	401
	2	1742	1731	1727	1718	1712	1708	1695	1714	1715	1718	1718	1702	1706	1565	1459	1377	1302	1246	1191	1153	1117	1103	
	3	1748	1100	1015	991	962	926	925	927	899	890	885	882	875	862	839	803	783	766	749	745	754	785	
	4	1757	1743	1740	1739	1731	1396	1140	1071	1033	969	937	911	899	896	898	882	862	845	829	816	804	805	
	5	1746	1724	1731	1720	1734	1719	1716	1724	1724	1708	1724	1720	1721	1729	1640	1483	1382	1298	1227	1172	1127	1108	
	6	1743	1728	1730	1726	1730	1732	1729	1724	1717	1717	1728	1720	1725	1727	1678	1522	1425	1330	1257	1199	1153	1134	
	7	1746	1739	1726	1736	1734	1731	1718	1713	1718	1733	1733	1730	1722	1729	1710	1552	1431	1347	1268	1202	1155	1138	
	8	1746	1666	1731	1713	1712	1713	1722	1714	1710	1707	1695	1707	1726	1717	1713	1619	1469	1385	1293	1225	1166	1152	
	9	1727	1737	1739	1650	1701	1708	1725	1720	1734	1724	1726	1714	1715	1721	1718	1583	1456	1357	1270	1199	1152	1130	
75	1	1739	1715	1724	1708	1715	1717	1711	1699	1708	1713	1710	1702	1702	1637	1522	1429	1362	1305	1258	0	1204	402	
	2	1734	1722	1717	1707	1700	1695	1682	1700	1699	1702	1701	1688	1703	1707	1699	1572	1455	1373	1299	1249	1205		1185
	3	1743	1107	1016	998	989	988	1006	1013	967	930	906	896	889	896	899	860	830	806	784	775	780		827
	4	1750	1735	1731	1733	1728	1738	1722	1732	1618	1389	1265	1182	1128	1084	1049	1020	991	963	937	915	895		893
	5	1737	1715	1721	1709	1722	1707	1703	1711	1710	1593	1708	1704	1704	1713	1707	1702	1600	1463	1363	1291	1234		1214
	6	1736	1719	1721	1715	1718	1720	1716	1711	1702	1702	1712	1704	1708	1711	1702	1700	1641	1490	1389	1314	1258		1237
	7	1738	1729	1715	1724	1721	1719	1704	1698	1702	1717	1717	1713	1708	1714	1703	1708	1695	1544	1425	1332	1273		1251
	8	1738	1657	1720	1701	1700	1700	1709	1701	1695	1693	1680	1690	1709	1701	1697	1693	1685	1631	1475	1377	1296		1279
	9	1719	1729	1729	1642	1691	1696	1713	1707	1720	1709	1710	1698	1699	1706	1702	1704	1711	1574	1440	1339	1275		1248

76	1	1736	1711	1720	1703	1710	1709	1703	1689	1698	1701	1698	1691	1689	1694	1695	1695	1635	1521	1422	1342	.0	1260	403
	2	1731	1719	1713	1702	1695	1687	1675	1691	1690	1692	1690	1676	1691	1696	1692	1690	1678	1548	1432	1352	1285	1260	
	3	1746	1319	1071	1011	990	986	994	1012	986	976	968	966	963	966	987	964	950	928	894	862	842	891	
	4	1738	1718	1713	1711	1705	1710	1692	1702	1699	1687	1698	1673	1689	1697	1693	1697	1693	1633	1506	1393	1316	1289	
	5	1735	1712	1717	1704	1715	1700	1696	1702	1701	1684	1699	1694	1693	1704	1695	1692	1698	1689	1551	1435	1343	1313	
	6	1733	1716	1716	1710	1712	1713	1708	1702	1694	1693	1701	1693	1698	1701	1691	1692	1704	1689	1578	1455	1364	1331	
	7	1736	1726	1713	1720	1717	1714	1699	1693	1696	1709	1708	1703	1695	1703	1692	1698	1695	1701	1671	1514	1410	1366	
	8	1735	1655	1717	1697	1697	1695	1703	1694	1688	1684	1670	1680	1698	1690	1686	1683	1674	1696	1686	1584	1449	1411	
	9	1716	1724	1724	1638	1685	1691	1705	1698	1711	1699	1699	1687	1687	1694	1689	1692	1698	1694	1652	1502	1402	1357	
77	1	1753	1727	1736	1718	1725	1724	1717	1705	1713	1717	1711	1706	1703	1708	1706	1699	1638	1544	1475	1417	0	1352	404
	2	1749	1739	1734	1724	1713	1706	1691	1708	1706	1708	1704	1691	1707	1713	1709	1707	1697	1636	1514	1446	1378	1355	
	3	1763	1754	1752	1737	1600	1369	1244	1171	1102	1066	1035	1014	997	983	986	975	963	955	943	927	905	935	
	4	1756	1738	1732	1729	1722	1728	1707	1719	1715	1701	1713	1688	1704	1711	1707	1711	1705	1689	1560	1469	1399	1385	
	5	1753	1730	1735	1721	1733	1717	1712	1718	1716	1698	1714	1709	1709	1718	1709	1707	1714	1704	1605	1505	1429	1410	
	6	1750	1733	1734	1727	1730	1730	1725	1719	1709	1708	1717	1709	1713	1715	1707	1709	1721	1703	1691	1526	1459	1434	
	7	1754	1744	1729	1737	1734	1730	1715	1708	1711	1724	1723	1720	1709	1719	1707	1714	1709	1715	1697	1529	1463	1438	
	8	1754	1671	1733	1714	1712	1710	1719	1710	1703	1700	1684	1695	1713	1704	1701	1698	1687	1709	1686	1537	1454	1446	
	9	1734	1742	1740	1651	1700	1705	1721	1714	1726	1714	1713	1701	1702	1709	1703	1708	1712	1691	1552	1466	1414	1392	

TABLE IV. - Continued. RADIATOR TUBE SURFACE TEMPERATURES

		(b) SI Units																						
		DISTANCE FROM TUBE INLET TO THERMOCOUPLE, CM																						
RUN	TUBE	5	25	46	66	86	107	127	147	168	188	208	229	249	269	290	310	330	351	371	391	411	432	O-R
		TEMPERATURES, DEGREES KELVIN																						
1	1	918	909	917	910	916	916	912	838	732	667	619	583	554	533	514	499	485	473	463	454	0	442	354
	2	914	914	914	911	908	906	902	851	734	665	616	579	553	531	512	497	482	471	460	451	443	439	
	3	914	913	913	908	911	910	902	752	663	612	571	541	518	499	482	469	458	448	436	427	422	418	
	4	917	912	911	912	916	916	908	911	783	679	616	568	538	514	496	479	464	453	443	433	427	423	
	5	915	908	914	909	916	909	909	911	792	682	616	570	538	513	494	477	463	452	442	432	424	421	
	6	916	911	913	911	914	916	915	912	797	688	621	575	542	518	497	481	467	455	444	436	428	424	
	7	918	916	911	916	917	914	910	906	795	694	622	576	541	518	498	481	466	455	444	434	427	421	
	8	917	879	913	906	905	906	912	905	803	695	618	573	541	515	494	478	464	453	442	433	424	422	
	9	907	916	916	875	900	903	913	909	799	589	614	568	534	511	491	474	461	449	438	429	422	417	
2	1	906	898	905	899	903	905	901	897	851	737	664	614	578	552	529	511	494	482	471	460	0	447	352
	2	903	902	902	899	897	896	891	899	874	746	666	614	579	551	528	509	493	480	468	458	449	445	
	3	902	902	901	896	899	899	899	893	861	723	641	592	557	527	508	490	476	463	450	439	432	430	
	4	906	901	899	901	904	904	897	901	902	781	673	607	567	537	514	494	477	465	453	443	435	432	
	5	904	897	903	898	905	898	898	901	903	774	670	606	567	536	512	492	477	463	452	442	434	430	
	6	904	900	902	901	903	905	904	903	899	783	677	613	570	541	516	496	481	467	455	446	437	433	
	7	907	904	900	904	905	902	898	895	899	792	677	613	570	540	516	496	480	467	455	444	436	429	
	8	906	869	901	894	894	894	901	894	894	796	673	610	570	537	513	493	476	465	452	442	434	430	
	9	897	904	904	864	889	892	902	899	902	783	666	604	562	532	508	489	474	461	449	439	431	427	
3	1	914	904	912	905	909	911	906	903	909	909	833	737	674	631	597	571	549	531	516	502	0	486	350
	2	910	909	908	906	903	901	896	905	905	905	842	739	677	632	598	571	548	530	514	501	489	484	
	3	909	908	908	902	905	905	906	899	905	908	867	742	673	619	592	561	540	523	507	491	477	477	
	4	913	908	906	907	911	912	903	907	907	902	910	790	704	644	603	573	547	526	509	494	483	478	
	5	912	904	910	904	912	904	904	908	909	899	910	790	700	642	602	570	546	525	508	494	482	477	
	6	912	906	908	907	909	911	910	909	906	904	911	801	708	650	607	576	553	530	513	499	487	481	
	7	914	912	907	912	912	909	906	902	906	912	913	808	709	652	609	578	551	532	514	498	487	478	
	8	913	875	908	901	900	901	907	899	901	899	895	819	719	652	608	574	547	529	510	496	482	478	
	9	904	912	912	871	896	898	908	906	910	907	908	801	703	644	602	571	546	526	508	492	481	475	
4	1	921	912	919	912	917	918	913	910	915	916	818	735	678	639	607	581	559	541	526	512	0	495	355
	2	918	916	916	913	909	908	903	912	913	911	809	727	675	635	603	578	556	538	521	509	497	492	
	3	917	916	915	909	912	912	913	908	913	913	809	717	662	614	591	562	542	526	511	494	481	479	
	4	920	914	913	914	917	917	909	914	914	909	917	812	725	662	618	587	561	537	519	504	491	485	
	5	918	911	917	911	918	911	911	914	914	906	918	819	723	662	619	584	559	538	519	504	491	485	
	6	918	913	915	913	916	918	917	916	912	911	917	831	732	670	624	591	567	542	524	508	495	489	
	7	921	918	912	917	917	915	911	908	911	917	919	839	734	671	626	593	564	543	524	507	494	484	
	8	919	881	914	907	906	907	913	907	907	906	901	862	751	676	627	591	562	542	521	506	491	486	
	9	911	918	917	876	901	904	914	912	915	913	914	844	734	668	622	587	561	538	519	502	489	482	
5	1	917	907	914	908	912	913	908	906	911	913	886	769	699	652	614	585	561	541	524	510	0	493	351
	2	913	912	912	908	906	904	898	908	903	909	893	773	704	653	615	586	560	541	523	509	497	492	
	3	913	912	911	905	907	907	908	902	908	911	908	782	701	643	610	576	551	533	517	499	484	486	
	4	916	910	908	909	913	914	906	909	910	904	913	843	742	672	625	590	561	537	518	504	491	486	
	5	914	906	913	907	913	907	906	909	911	903	913	844	736	671	623	587	559	537	518	504	491	486	
	6	915	909	911	909	912	914	913	912	903	907	913	856	744	678	629	592	567	541	523	508	495	489	
	7	917	914	909	913	913	912	907	904	907	913	915	863	746	679	631	596	564	543	523	507	494	486	
	8	916	877	910	903	902	903	909	902	903	901	897	878	759	682	631	592	561	539	519	504	491	486	
	9	907	914	913	873	897	900	910	907	912	909	911	857	740	672	624	588	559	536	517	501	489	482	

6	1	907	897	903	897	901	902	901	896	901	901	821	739	681	639	609	583	559	541	527	516	0	503	417	
	2	905	902	900	897	894	892	888	895	897	897	852	755	694	647	611	584	559	540	525	515	506	502		
	3	902	900	899	893	895	896	894	893	895	899	897	835	732	668	626	588	559	541	525	512	497	498		
	4	906	899	901	898	898	901	893	898	893	893	901	839	741	669	622	588	558	535	519	508	497	493		
	5	905	895	899	894	902	895	894	898	899	892	901	844	737	667	619	582	554	533	517	506	496	491		
	6	904	898	899	897	900	901	900	899	896	896	902	855	745	676	626	590	563	538	523	512	501	497		
	7	906	902	898	902	902	901	896	894	897	903	904	872	750	679	627	591	559	537	522	510	499	494		
	8	906	867	899	891	891	892	897	894	893	891	886	886	772	686	630	591	557	536	519	508	497	493		
	9	897	901	902	862	886	889	898	895	903	898	900	876	751	676	623	586	557	533	517	503	493	489		
7	1	902	893	897	892	896	896	894	889	894	896	894	802	728	678	639	609	583	563	545	529	0	510	418	
	2	900	897	895	892	890	887	883	891	891	892	893	828	745	687	643	611	583	561	542	527	514	507		
	3	898	895	894	888	889	889	888	888	891	893	891	888	814	720	668	621	587	566	544	524	508	504		
	4	902	894	896	893	892	895	888	893	892	887	894	881	822	724	666	622	587	560	539	522	507	501		
	5	900	891	894	888	896	889	889	892	893	886	895	891	819	724	663	618	586	558	536	519	505	498		
	6	899	892	893	892	894	894	894	893	890	890	896	891	830	734	670	626	594	564	542	525	511	503		
	7	901	897	892	895	896	894	889	887	890	897	898	894	847	742	674	628	591	564	542	522	508	500		
	8	901	862	893	885	885	886	891	888	885	885	879	884	876	755	682	631	591	565	541	523	506	501		
	9	892	896	897	857	881	883	892	889	897	892	894	888	846	738	671	623	588	560	537	517	503	497		
8	1	913	903	909	902	906	907	902	898	903	905	906	899	843	765	709	669	634	608	586	567	0	543	357	
	2	909	908	907	902	899	897	892	901	901	902	901	895	868	777	716	672	635	608	583	564	547	539		
	3	909	907	906	900	902	902	902	897	902	906	904	900	878	771	706	652	617	593	570	548	528	525		
	4	911	905	903	903	906	906	898	902	902	897	903	892	901	881	778	706	656	619	591	567	548	539		
	5	910	901	907	900	907	899	898	902	902	894	904	902	902	887	778	706	657	620	590	568	547	539		
	6	910	904	904	903	905	906	904	903	899	898	904	901	903	897	788	716	668	626	597	573	554	544		
	7	912	908	902	907	906	903	899	896	899	906	907	904	902	903	802	726	668	631	599	573	553	538		
	8	911	872	904	896	895	896	901	895	894	893	888	894	901	897	825	733	672	634	599	575	552	544		
	9	902	908	907	867	891	893	902	899	903	901	902	898	898	898	798	720	665	625	593	567	548	537		
9	1	899	887	891	884	886	886	883	877	880	882	881	877	877	878	830	762	706	664	629	601	0	568	415	
	2	897	892	889	884	880	876	871	879	877	873	878	873	879	881	864	792	727	678	636	606	582	571		
	3	894	889	887	880	881	879	877	876	877	879	877	875	877	874	881	853	769	702	658	617	588	579		
	4	898	889	889	884	883	884	877	881	881	873	874	881	868	877	881	881	856	762	698	649	611	582		571
	5	898	886	888	881	887	879	878	881	881	873	881	878	879	883	881	852	763	696	645	609	580	568		
	6	897	887	887	884	884	884	883	881	877	877	881	878	881	881	878	865	779	708	657	617	587	576		
	7	898	892	886	887	886	884	878	875	877	883	883	881	878	882	877	879	794	723	665	620	588	575		
	8	897	857	886	877	877	876	879	875	874	872	866	871	879	876	874	873	801	729	669	626	589	578		
	9	889	891	889	849	872	873	880	878	883	879	879	874	875	878	877	872	778	707	652	610	581	568		
10	1	893	880	882	874	874	873	869	862	864	864	863	859	859	861	861	861	821	754	704	665	0	621	414	
	2	891	884	880	874	869	864	858	863	862	861	859	854	860	863	859	861	856	784	722	679	643	628		
	3	889	882	879	870	870	866	862	850	862	852	859	857	858	856	861	852	857	836	752	696	659	642		
	4	893	883	881	876	873	872	864	863	863	859	863	851	859	862	862	863	859	816	744	688	648	634		
	5	892	878	879	871	876	867	864	865	864	856	862	859	860	864	861	860	862	825	743	689	648	632		
	6	891	880	878	874	873	872	869	855	862	860	864	860	862	863	859	859	864	849	765	705	661	643		
	7	892	884	877	878	875	872	865	851	862	867	866	863	861	863	859	862	861	862	781	712	665	646		
	8	892	849	877	867	866	864	866	862	858	856	850	854	861	858	856	857	851	859	787	718	667	651		
	9	883	884	881	841	861	861	867	863	868	862	862	857	857	861	859	859	863	844	754	692	651	633		

TABLE IV. - Continued. RADIATOR TUBE SURFACE TEMPERATURES

		(b) Continued. SI Units																						
		DISTANCE FROM TUBE INLET TO THERMOCOUPLE, CM																						
RUN	TUBE	5	25	46	66	86	107	127	147	168	188	208	229	249	269	290	310	330	351	371	391	411	432	D-R
		TEMPERATURES, DEGREES KELVIN																						
11	1	899	885	888	879	881	879	874	868	870	871	869	864	864	866	866	867	842	777	721	677	0	631	415
	2	897	890	886	880	875	870	863	869	867	867	866	860	866	868	865	866	864	801	736	690	653	639	
	3	894	888	884	876	876	873	869	867	868	868	865	863	864	861	867	858	863	862	775	711	671	654	
	4	898	887	887	881	878	878	870	873	869	864	869	857	864	868	868	869	864	853	771	706	660	646	
	5	897	884	884	877	882	873	871	872	871	862	869	866	866	871	867	866	867	856	767	707	661	644	
	6	896	886	884	879	879	878	875	872	867	856	870	866	867	868	865	865	871	861	779	718	673	555	
	7	898	891	883	883	881	878	871	867	868	873	872	869	866	869	864	867	866	868	804	729	678	659	
	8	898	855	883	874	871	870	872	858	864	862	856	859	867	863	861	862	856	865	813	738	681	664	
	9	888	889	887	846	867	867	873	869	874	868	868	862	863	866	864	864	868	864	778	709	664	646	
12	1	968	958	967	956	894	741	656	601	564	536	513	494	479	466	454	444	435	427	420	413	0	404	355
	2	964	963	963	854	688	607	555	524	497	477	461	447	436	426	416	408	401	394	388	384	379	378	
	3	966	962	961	944	749	639	575	532	504	481	463	448	436	426	414	407	402	393	384	382	382	376	
	4	969	962	962	958	798	669	593	552	517	492	474	456	444	434	425	415	407	399	394	388	384	383	
	5	967	958	964	957	963	761	654	594	553	521	498	478	463	450	439	430	421	413	407	400	394	392	
	6	967	960	963	961	964	802	676	605	558	526	502	482	466	453	442	431	423	414	407	401	395	393	
	7	968	967	961	967	967	849	684	605	555	525	498	479	461	448	437	426	417	409	402	394	389	386	
	8	968	924	963	953	954	846	687	607	554	523	496	476	461	446	435	424	415	408	399	393	388	386	
	9	958	967	967	917	947	786	659	589	542	512	487	468	453	440	429	419	411	403	396	389	385	381	
13	1	971	959	969	959	967	944	788	697	641	522	570	544	524	508	493	481	469	459	451	443	0	432	354
	2	967	966	964	961	957	791	686	629	584	553	527	506	490	476	463	453	443	435	427	421	414	411	
	3	968	964	963	956	958	843	712	639	588	556	528	507	491	474	462	451	444	434	423	416	413	408	
	4	971	964	963	964	966	912	743	663	609	558	541	514	498	483	471	459	448	439	431	424	418	416	
	5	969	959	967	960	969	959	890	739	654	598	562	532	510	492	477	463	453	443	434	426	419	416	
	6	968	962	964	963	966	967	928	754	660	526	567	536	513	494	479	465	454	444	434	427	420	417	
	7	971	969	963	969	969	967	919	751	659	639	567	537	513	495	479	466	454	444	435	427	420	414	
	8	971	926	965	956	957	955	939	758	659	608	564	534	513	493	477	464	452	443	433	426	418	416	
	9	959	968	969	920	950	952	915	747	655	603	561	531	508	489	474	461	450	441	431	423	417	412	
14	1	979	968	977	968	975	973	848	745	683	638	603	575	553	537	521	508	494	483	473	463	0	450	363
	2	975	974	974	970	967	853	734	673	622	586	559	539	523	507	492	479	467	456	446	438	432	428	
	3	977	973	971	964	968	922	772	688	629	594	564	543	526	507	495	480	469	458	446	436	431	427	
	4	979	973	972	973	975	971	822	729	664	615	584	557	539	525	510	496	481	468	457	448	440	437	
	5	978	968	975	969	978	968	967	814	711	645	602	569	547	528	511	494	479	467	454	444	437	434	
	6	978	971	974	971	975	976	976	851	725	658	610	574	549	529	512	496	482	468	456	447	438	436	
	7	979	978	971	978	978	977	969	847	725	663	610	575	548	530	513	496	481	469	457	446	438	432	
	8	979	934	974	964	966	964	972	859	728	663	608	574	551	529	512	496	480	468	455	446	437	434	
	9	968	977	978	928	958	961	973	859	729	661	607	571	546	526	508	492	478	466	454	443	435	430	
15	1	978	967	977	967	974	973	893	792	730	683	646	615	588	568	548	533	519	507	495	484	0	472	351
	2	974	973	972	969	966	926	799	735	679	638	606	577	556	538	522	507	493	482	472	464	457	453	
	3	976	972	970	963	966	965	854	760	697	653	616	587	563	541	527	511	498	487	476	464	458	456	
	4	978	972	971	972	974	973	922	809	732	674	634	598	571	551	532	517	501	487	477	468	459	455	
	5	977	967	974	968	977	967	968	941	801	716	658	614	581	554	533	514	498	485	472	463	454	451	
	6	977	969	972	971	974	976	975	964	820	732	669	623	587	560	537	519	503	487	476	466	457	453	
	7	978	976	971	976	977	976	968	955	817	737	669	623	586	561	538	519	502	488	476	465	457	450	
	8	978	933	973	963	964	963	971	957	814	733	664	622	590	561	538	519	502	489	476	466	457	453	
	9	967	976	976	926	957	960	972	897	778	711	655	616	586	559	538	520	505	491	478	467	459	454	

16	1	974	963	972	963	969	970	961	819	736	678	634	600	573	553	535	521	507	495	486	474	0	462	352
	2	970	969	968	965	962	955	833	743	672	524	589	562	542	525	509	496	483	473	463	455	448	444	
	3	971	968	966	959	962	962	893	771	689	638	598	569	547	526	513	498	487	476	464	453	447	444	
	4	974	967	967	967	969	969	959	852	743	670	623	586	561	542	526	511	496	482	472	463	455	451	
	5	972	962	969	963	972	963	963	959	815	711	646	601	569	545	525	507	492	479	468	458	450	446	
	6	972	965	968	966	969	971	970	962	829	725	656	638	574	550	529	512	498	483	471	462	453	449	
	7	974	972	966	972	972	971	964	954	825	731	657	610	575	551	530	513	496	483	472	461	453	446	
	8	973	929	968	959	960	959	967	957	835	734	656	639	577	550	529	512	496	484	471	461	452	449	
	9	963	971	972	922	952	956	968	959	841	733	654	606	571	546	526	509	494	481	469	458	450	445	
17	1	971	959	968	960	967	967	964	912	829	755	696	648	611	586	566	551	537	524	513	501	0	487	350
	2	966	966	964	962	958	956	949	863	784	712	656	612	586	566	549	535	520	508	496	485	476	472	
	3	967	964	963	956	958	960	962	911	828	742	674	626	593	569	555	537	524	512	499	486	474	474	
	4	971	964	963	964	966	967	957	962	925	824	728	652	607	579	560	545	528	512	498	486	476	471	
	5	969	959	966	960	968	960	959	963	964	859	753	673	620	586	563	543	527	512	497	484	474	470	
	6	968	962	964	962	966	968	967	965	959	862	764	685	629	594	568	549	534	516	502	489	479	474	
	7	971	968	963	969	968	968	961	955	960	870	763	686	628	593	568	550	532	518	502	489	478	470	
	8	970	926	966	966	957	957	963	955	955	865	764	687	632	592	568	549	531	518	502	489	477	473	
	9	959	968	969	919	949	953	964	959	924	856	749	674	619	584	564	546	531	516	502	487	477	471	
18	1	967	957	964	957	962	964	963	954	925	822	748	692	650	620	595	574	556	541	527	516	0	501	413
	2	965	962	961	957	955	952	948	955	929	822	747	689	650	620	594	574	554	539	525	514	504	499	
	3	966	962	961	953	956	958	958	952	843	757	689	645	612	582	565	543	529	517	504	492	479	479	
	4	969	961	961	959	958	963	953	961	962	949	828	731	675	632	600	576	553	534	519	507	496	491	
	5	967	957	961	956	964	957	956	961	962	948	830	737	677	633	600	573	552	534	518	506	494	489	
	6	966	958	961	959	962	963	963	961	953	843	747	684	641	606	580	560	540	524	511	501	495		
	7	968	965	958	964	964	963	957	954	958	846	752	684	642	608	582	558	541	524	510	499	494		
	8	968	924	961	952	952	952	959	955	954	874	768	703	649	612	584	558	542	524	511	498	494		
	9	957	963	965	917	946	950	961	958	967	959	870	761	693	644	609	581	558	539	522	507	497	490	
19	1	971	961	967	960	965	967	964	958	964	965	917	816	745	697	660	631	605	584	566	550	0	531	412
	2	968	965	964	961	957	955	951	960	959	960	917	813	747	698	660	632	606	584	564	550	537	530	
	3	969	964	963	956	958	961	961	957	958	962	918	811	737	686	653	619	592	576	558	540	523	524	
	4	972	963	963	963	960	966	956	963	963	957	965	906	810	733	683	644	613	587	566	548	533	527	
	5	972	960	964	959	968	959	958	963	964	954	966	918	811	734	683	643	613	587	564	548	532	527	
	6	970	962	964	962	964	966	966	963	959	959	966	941	826	748	692	652	623	594	572	554	539	533	
	7	971	968	961	967	967	966	959	957	960	968	969	959	836	755	698	657	623	598	574	554	539	532	
	8	971	927	963	954	954	956	962	958	955	954	947	951	876	774	711	665	626	602	576	557	538	533	
	9	961	967	968	919	949	953	963	961	969	963	965	954	842	757	698	656	622	594	571	551	536	527	
20	1	967	956	962	954	959	959	957	950	955	958	956	952	951	948	846	785	734	697	667	640	0	609	409
	2	964	961	958	954	951	948	943	952	951	953	952	945	954	954	862	794	741	702	668	642	620	612	
	3	964	959	957	949	951	953	952	948	949	954	950	949	951	945	944	817	761	711	680	649	628	619	
	4	967	959	957	956	953	958	949	955	955	948	956	942	951	956	952	849	777	724	686	653	626	618	
	5	967	954	958	952	960	952	951	955	956	947	956	953	953	959	954	846	778	726	684	653	627	617	
	6	966	957	958	956	958	959	958	956	951	951	957	953	955	957	952	859	793	735	693	661	635	626	
	7	967	963	956	961	960	959	952	949	951	959	959	957	953	957	952	879	798	744	699	664	637	627	
	8	967	922	958	948	948	948	954	950	947	945	938	944	955	950	948	938	813	758	708	673	641	633	
	9	956	962	962	914	942	946	955	952	961	954	955	948	949	953	951	869	795	738	691	656	631	619	

TABLE IV. - Continued. RADIATOR TUBE SURFACE TEMPERATURES

(b) Continued. SI Units

RUN	TUBE	DISTANCE FROM TUBE INLET TO THERMOCOUPLE, CM																				O-R		
		5	25	46	66	86	107	127	147	168	188	208	229	249	269	290	310	330	351	371	391		411	432
		TEMPERATURES, DEGREES KELVIN																						
21	1	967	954	959	951	955	956	953	947	951	954	952	947	947	946	918	850	788	745	711	684	0	651	407
	2	964	959	957	952	948	945	939	949	943	949	948	941	950	952	946	906	826	766	721	691	663	553	
	3	964	958	956	948	948	951	949	946	946	950	947	945	947	943	952	930	869	798	742	702	677	665	
	4	967	958	956	955	952	956	946	953	952	945	952	938	948	952	951	949	877	797	746	704	673	663	
	5	967	953	957	951	958	950	948	952	952	943	952	949	950	956	951	946	885	803	744	706	673	662	
	6	965	956	957	954	956	957	955	952	943	947	953	949	952	953	949	947	911	820	758	717	684	573	
	7	967	963	954	959	958	957	949	945	949	956	956	954	951	955	949	951	929	846	774	724	691	678	
	8	967	922	957	947	947	946	951	947	944	942	936	941	952	947	946	943	932	864	785	735	696	685	
	9	956	961	961	912	940	943	953	949	957	951	952	944	946	949	947	945	900	823	758	712	682	667	
22	1	967	952	957	948	952	952	949	942	947	949	947	943	943	943	939	887	826	789	758	729	0	697	405
	2	963	958	956	951	947	943	937	945	944	946	944	937	945	948	946	942	916	856	797	754	719	708	
	3	963	957	954	947	947	948	947	942	943	947	942	941	942	938	947	933	934	896	820	764	735	717	
	4	967	957	954	953	949	953	943	949	943	942	948	933	942	948	945	947	942	879	814	763	729	718	
	5	966	953	956	949	956	947	946	949	949	939	948	944	945	951	946	944	945	891	815	769	731	719	
	6	964	956	956	952	954	954	952	949	944	944	949	945	947	949	943	944	951	903	832	781	744	730	
	7	966	962	953	958	957	954	947	943	945	953	952	950	946	951	944	947	946	919	847	786	747	733	
	8	966	921	956	945	944	944	948	943	941	938	931	937	947	943	940	938	933	931	849	793	746	737	
	9	955	959	959	911	937	941	949	946	952	947	947	941	941	944	943	943	942	872	806	756	724	711	
23	1	966	952	957	948	952	952	948	942	947	948	947	943	942	944	942	895	835	793	756	724	0	689	405
	2	963	958	956	951	947	943	936	946	946	945	943	937	944	948	946	942	926	856	793	751	714	702	
	3	964	957	954	947	947	948	947	942	943	946	942	941	941	938	946	932	936	893	820	762	731	712	
	4	967	958	955	953	949	953	943	949	948	941	947	933	942	947	944	947	943	880	817	762	723	711	
	5	966	953	956	948	956	947	944	949	948	938	947	944	944	951	946	944	947	892	818	767	725	712	
	6	964	954	956	952	954	954	952	949	944	943	949	944	947	949	943	943	951	909	836	781	739	723	
	7	966	962	953	958	956	955	947	943	945	953	952	949	946	950	944	947	945	928	852	788	745	729	
	8	966	921	956	946	944	944	948	944	941	938	931	936	946	942	939	938	933	941	854	797	746	735	
	9	956	959	959	911	938	941	949	945	952	946	947	940	941	944	942	943	943	879	814	759	723	707	
24	1	974	964	971	958	946	894	836	777	731	693	660	633	611	593	577	564	552	541	531	521	0	508	421
	2	972	968	968	962	946	903	841	792	735	693	657	628	607	588	571	558	544	534	522	513	504	500	
	3	972	967	965	957	954	926	869	802	739	689	647	618	594	573	561	544	532	522	511	498	488	487	
	4	974	967	968	964	956	939	892	808	732	671	627	590	567	551	533	519	503	492	481	473	466	463	
	5	974	963	967	961	970	961	946	867	788	709	650	605	576	553	534	516	501	488	477	468	461	458	
	6	972	965	967	965	969	968	963	907	807	729	667	619	585	561	540	523	508	493	482	473	464	462	
	7	973	971	964	969	970	967	953	889	801	730	663	618	583	561	539	523	507	494	483	473	465	462	
	8	973	929	966	957	957	952	921	852	763	709	651	614	587	563	544	529	512	501	489	481	471	469	
	9	963	970	972	921	947	905	841	764	707	664	627	594	570	552	537	523	511	499	489	479	472	458	
25	1	975	964	972	964	969	963	891	818	769	719	681	649	624	606	588	573	558	547	536	525	0	512	422
	2	972	969	968	964	962	954	919	839	779	723	679	645	622	602	583	567	552	540	527	518	508	503	
	3	972	968	966	959	962	962	956	862	794	729	674	640	614	590	574	555	541	531	518	504	494	493	
	4	976	968	969	967	966	968	957	925	815	737	668	623	596	573	552	536	518	504	492	482	473	470	
	5	974	963	968	962	972	963	963	952	879	782	700	644	609	582	558	539	523	508	494	484	475	471	
	6	973	966	968	966	969	971	970	963	893	797	716	656	618	590	566	546	531	514	501	491	481	477	
	7	974	971	964	969	970	969	963	954	862	793	707	654	615	589	565	547	529	516	502	491	481	477	
	8	974	930	967	957	957	958	963	922	825	761	685	643	615	588	567	548	531	519	506	496	486	482	
	9	964	971	972	922	953	948	877	809	744	638	646	616	592	573	556	541	528	516	504	493	485	481	

26	1	974	963	971	963	969	968	946	843	784	737	698	664	637	615	594	578	563	551	539	529	0	516	423
	2	971	968	967	963	961	957	947	873	795	741	698	662	635	611	588	572	556	544	531	522	513	508	
	3	972	967	966	958	961	963	962	935	829	758	703	664	632	602	582	561	546	535	523	509	497	497	
	4	975	967	968	966	964	968	960	952	883	783	712	657	618	588	564	547	529	514	502	491	481	477	
	5	973	962	967	961	971	962	962	965	954	817	736	676	632	597	571	549	533	519	504	493	483	479	
	6	972	965	967	964	968	969	969	955	955	829	747	686	642	607	579	558	542	525	512	500	489	485	
	7	973	970	964	969	969	968	962	958	942	823	739	683	638	605	578	558	539	525	512	499	489	484	
	8	974	929	967	957	957	958	964	955	866	784	714	670	636	602	577	557	539	527	514	503	493	489	
	9	963	970	972	922	953	954	931	831	762	713	671	635	604	579	561	546	533	521	509	498	490	485	
27	1	970	959	966	958	963	958	922	872	830	794	761	729	703	683	663	647	631	618	606	595	0	581	439
	2	967	963	962	958	956	951	939	912	857	813	769	727	699	673	650	633	614	600	585	574	564	559	
	3	968	962	960	953	955	958	957	949	916	856	801	738	694	662	639	613	593	582	567	552	538	538	
	4	970	962	963	961	958	963	954	960	959	907	843	760	709	668	637	611	588	570	554	541	527	523	
	5	969	958	962	956	965	957	956	960	959	912	845	768	711	668	636	608	586	568	551	538	526	521	
	6	967	961	962	960	963	964	963	961	955	917	852	775	718	676	642	616	596	574	558	545	533	528	
	7	969	966	959	964	964	963	957	953	949	903	828	761	704	669	638	613	591	574	558	544	532	527	
	8	969	925	961	952	952	952	959	948	901	843	777	729	696	662	637	616	593	581	566	554	542	538	
	9	959	965	966	917	947	948	954	889	839	794	756	718	690	667	646	628	613	598	584	571	563	559	
28	1	970	959	966	958	964	965	961	914	848	799	758	721	691	668	646	629	612	599	586	574	0	558	430
	2	967	964	962	958	956	953	948	951	899	827	771	724	691	662	637	618	599	583	567	556	545	540	
	3	968	963	961	954	955	959	958	955	954	933	820	746	697	659	633	606	583	570	555	539	523	525	
	4	970	962	963	961	959	963	954	962	963	952	876	770	716	668	634	608	582	562	545	531	519	514	
	5	969	958	962	956	965	957	956	961	963	950	875	776	715	668	633	604	581	561	543	530	517	512	
	6	967	960	962	960	963	964	963	962	958	954	878	782	721	675	639	611	589	567	550	536	524	518	
	7	969	966	959	964	964	964	957	954	953	954	852	770	711	668	634	608	584	566	549	534	523	518	
	8	970	926	962	952	952	953	960	955	951	876	795	738	698	658	630	607	583	569	553	541	528	525	
	9	959	965	967	918	947	951	962	951	860	796	743	702	669	644	623	603	587	571	556	543	533	529	
29	1	975	964	971	963	969	970	968	919	828	758	726	689	658	634	613	596	581	568	555	543	0	526	424
	2	972	969	968	964	962	958	954	950	855	780	731	691	661	633	610	593	576	562	546	534	523	517	
	3	972	967	966	958	960	964	964	960	952	843	759	704	664	629	607	582	564	551	535	518	504	503	
	4	975	967	968	966	964	969	959	967	963	902	776	706	662	626	596	575	554	535	519	506	493	488	
	5	974	963	967	962	971	963	962	967	968	929	799	724	674	634	603	579	559	541	523	509	497	492	
	6	972	966	967	965	968	969	969	967	964	950	807	731	682	642	610	587	568	548	531	517	503	498	
	7	974	971	964	970	970	969	963	959	964	934	797	729	676	639	608	586	565	547	530	514	503	497	
	8	974	930	967	957	957	958	965	961	957	882	763	712	672	633	605	584	563	548	531	517	503	499	
	9	964	970	972	922	952	956	967	954	827	757	711	667	631	604	586	568	553	536	520	506	495	491	
30	1	969	958	964	957	962	963	958	937	864	820	782	748	721	701	681	663	646	632	619	606	0	591	440
	2	967	963	962	958	955	952	947	953	943	883	807	758	726	697	671	650	629	612	594	582	570	555	
	3	967	961	959	953	954	958	957	953	953	953	913	815	749	703	673	639	613	596	579	561	544	544	
	4	969	962	962	959	957	962	953	959	961	952	951	828	764	711	674	643	615	592	572	557	542	537	
	5	968	957	961	955	964	956	955	959	961	950	952	836	763	711	674	641	614	591	570	556	541	535	
	6	967	959	961	959	962	963	961	959	955	954	954	842	770	718	678	648	623	597	577	562	547	542	
	7	968	965	958	963	963	962	956	953	956	963	937	825	753	708	672	645	616	596	576	560	547	541	
	8	968	924	961	951	951	951	958	953	951	930	829	771	729	692	664	640	615	599	582	568	554	551	
	9	959	964	965	916	946	947	957	947	894	830	784	743	715	691	670	651	634	618	602	587	577	573	

TABLE IV. - Continued. RADIATOR TUBE SURFACE TEMPERATURES

(b) Continued. SI Units

RUN	TUBE	DISTANCE FROM TUBE INLET TO THERMOCOUPLE, CM																				D-R		
		5	25	46	66	86	107	127	147	168	188	208	229	249	269	290	310	330	351	371	391		411	432
		TEMPERATURES, DEGREES KELVIN																						
31	1	969	958	965	957	963	963	962	949	882	836	785	740	707	683	659	639	621	607	592	580	0	564	429
	2	967	963	962	958	955	952	947	955	949	878	818	756	715	682	653	631	609	592	574	562	550	545	
	3	966	961	959	953	954	957	957	953	954	954	904	828	747	691	657	623	597	582	566	548	532	532	
	4	969	961	962	959	957	961	953	960	961	953	954	834	764	702	661	628	601	578	559	544	531	526	
	5	968	957	961	955	964	956	955	959	962	951	954	840	762	702	660	626	599	576	557	543	529	524	
	6	967	959	961	958	962	963	962	950	955	956	956	846	769	709	666	633	608	583	564	549	536	530	
	7	968	965	958	964	964	963	956	953	957	963	906	843	754	701	661	630	602	582	563	547	534	529	
	8	968	924	960	951	951	951	958	954	952	944	849	791	732	684	651	624	598	582	564	551	537	533	
	9	958	963	965	917	946	949	959	954	958	858	796	733	693	663	637	615	596	579	563	549	539	535	
32	1	968	958	964	957	962	963	959	930	872	825	782	743	714	691	668	650	632	618	605	593	0	577	438
	2	966	962	961	957	954	952	947	952	933	870	809	756	721	689	660	639	617	602	585	572	561	555	
	3	966	961	959	952	954	957	956	953	953	953	888	816	750	702	668	633	607	592	574	556	539	539	
	4	968	961	961	959	956	961	952	959	960	952	916	829	763	708	668	635	608	586	567	552	537	532	
	5	967	956	961	954	963	955	954	959	961	949	914	836	762	708	667	632	607	584	565	551	536	531	
	6	966	958	960	958	961	962	961	959	955	954	917	843	768	716	672	639	615	591	572	557	543	537	
	7	967	964	958	963	963	962	955	952	956	961	909	825	753	706	666	636	608	589	570	554	541	536	
	8	967	924	959	950	950	951	957	953	951	916	834	776	730	688	656	631	605	590	573	559	546	542	
	9	958	963	964	916	944	948	958	951	904	849	791	743	708	679	654	633	615	599	583	569	558	554	
33	1	973	961	967	959	964	966	964	949	905	856	811	772	741	717	694	675	657	643	630	617	0	602	441
	2	969	966	964	960	957	954	949	958	952	940	872	805	761	722	689	665	642	624	606	593	579	574	
	3	970	964	962	955	957	959	959	956	957	962	956	923	819	746	702	661	632	615	597	578	561	559	
	4	972	964	964	962	959	963	955	962	962	956	962	916	824	752	704	666	636	612	592	575	559	553	
	5	971	960	963	958	967	958	957	962	963	953	962	928	825	754	704	664	635	611	589	573	558	551	
	6	970	962	964	962	964	966	963	962	958	958	963	935	835	765	711	672	645	617	597	580	564	558	
	7	971	968	961	966	966	964	957	955	953	966	963	908	807	748	701	667	636	616	595	577	563	557	
	8	972	927	963	953	953	954	960	955	954	948	903	818	768	721	686	658	632	617	598	584	568	566	
	9	961	967	967	918	948	951	960	952	948	879	819	772	737	709	684	663	646	630	614	600	590	586	
34	1	969	958	964	957	962	963	962	949	905	857	814	768	733	706	682	661	642	627	613	601	0	584	437
	2	967	963	961	957	955	952	947	955	953	931	863	799	752	713	679	653	629	612	593	580	567	552	
	3	967	961	959	953	954	957	957	953	954	957	951	881	808	739	698	655	626	609	591	571	554	552	
	4	969	961	962	959	957	961	953	959	961	952	958	878	817	744	698	658	628	605	585	567	552	546	
	5	968	957	961	954	964	956	955	959	961	951	959	885	816	745	696	656	627	603	582	566	550	544	
	6	967	959	961	958	961	963	961	959	955	956	961	894	823	753	702	663	636	609	589	572	557	551	
	7	968	964	958	963	963	962	955	953	956	963	958	877	807	742	694	659	628	608	587	569	555	549	
	8	968	924	960	951	950	951	957	954	951	946	886	828	773	718	681	649	622	607	587	573	558	554	
	9	958	964	964	916	945	948	958	953	958	890	846	782	737	702	672	647	627	610	593	578	567	563	
35	1	969	958	964	957	962	963	961	954	953	858	792	747	715	692	669	648	627	612	596	584	0	567	428
	2	967	963	962	957	955	952	947	955	957	951	845	769	726	694	664	639	615	597	579	567	554	549	
	3	967	961	959	952	954	957	957	953	954	958	956	932	761	709	676	637	607	592	574	557	541	539	
	4	969	961	961	959	956	961	952	959	960	953	961	932	776	716	678	642	611	588	569	553	538	533	
	5	968	957	961	954	964	956	954	959	960	951	962	942	773	716	677	639	610	587	567	552	537	532	
	6	967	959	961	958	962	963	962	950	955	956	962	942	781	723	683	647	619	593	574	558	543	538	
	7	968	965	959	963	963	962	956	953	956	964	965	942	768	718	679	646	613	592	573	556	542	536	
	8	968	923	959	951	949	951	957	953	951	949	939	887	746	702	670	639	609	591	572	558	543	539	
	9	958	964	965	916	945	948	959	956	964	952	815	746	708	681	654	628	606	588	572	557	546	542	

36	1	971	959	966	957	963	964	962	946	906	852	823	785	753	728	704	684	665	651	636	623	0	606	442
	2	967	964	963	958	956	953	947	957	954	943	892	829	783	739	702	675	648	629	609	595	581	574	
	3	968	962	960	953	954	957	957	953	954	959	956	919	842	776	723	676	644	624	605	584	566	562	
	4	971	962	963	961	958	962	953	961	961	953	962	912	843	778	723	681	648	622	601	582	563	557	
	5	969	958	962	956	964	957	956	960	961	951	962	926	846	781	723	679	648	621	598	580	562	554	
	6	968	960	962	959	962	964	962	961	957	956	963	937	857	793	731	688	657	627	605	586	569	552	
	7	969	966	959	964	964	963	956	953	957	964	963	909	832	774	719	682	648	626	604	584	568	561	
	8	969	925	961	952	951	951	958	954	952	947	899	836	793	739	699	670	641	624	605	589	573	569	
	9	960	965	966	917	946	949	958	951	935	877	831	786	751	721	696	674	655	638	621	606	596	592	
37	1	971	959	966	958	963	965	963	953	957	922	848	777	738	710	683	660	638	622	606	592	0	575	427
	2	968	965	963	959	957	954	949	958	957	952	916	821	767	724	686	655	628	608	588	575	562	555	
	3	968	963	961	954	956	959	958	955	956	960	953	940	826	752	709	663	628	607	587	568	552	549	
	4	971	962	963	961	958	963	954	961	962	954	959	936	851	757	709	667	632	604	584	567	551	544	
	5	969	958	962	957	966	957	957	961	962	953	959	947	851	758	708	664	630	603	581	565	549	543	
	6	968	961	963	960	963	964	963	961	957	957	960	948	861	766	714	672	640	609	588	571	556	549	
	7	970	967	961	965	966	964	958	954	953	966	963	949	853	761	711	671	634	609	587	570	554	548	
	8	970	926	962	953	952	953	959	955	953	949	940	917	804	743	699	662	626	606	586	571	554	550	
	9	959	966	967	918	947	950	961	957	963	954	909	836	756	714	677	645	619	599	581	564	553	548	
38	1	970	959	965	957	962	964	962	954	951	896	827	788	757	729	699	676	654	638	623	609	0	591	435
	2	967	963	962	958	955	952	947	957	957	955	929	831	784	748	706	673	644	623	603	587	573	567	
	3	967	962	959	953	954	957	957	953	954	959	956	947	858	775	732	680	646	624	603	581	563	560	
	4	969	962	962	960	957	962	953	959	959	953	961	937	851	777	733	683	648	622	599	579	562	557	
	5	968	957	961	955	963	956	954	959	960	951	962	948	850	779	732	681	647	619	596	578	561	554	
	6	967	960	961	959	962	963	961	959	955	956	962	949	861	786	739	691	658	627	604	585	568	562	
	7	969	966	958	963	963	963	956	953	956	964	965	948	839	786	733	688	651	626	602	582	567	560	
	8	969	924	961	951	951	951	957	954	951	949	941	889	803	764	719	678	643	623	602	585	567	563	
	9	959	964	965	916	945	949	959	956	964	953	892	803	767	739	702	669	645	624	605	588	575	570	
39	1	970	959	966	958	963	964	963	954	932	881	841	813	764	724	694	671	648	631	614	599	0	580	431
	2	967	963	962	958	956	953	947	957	957	948	891	843	803	743	699	670	642	621	599	584	569	553	
	3	967	962	959	953	954	958	958	954	954	959	956	901	843	789	724	676	646	623	603	581	564	561	
	4	969	962	962	961	958	962	954	961	961	954	961	884	844	794	727	682	649	623	599	580	563	557	
	5	969	958	962	956	964	956	956	961	961	952	962	893	850	792	724	680	648	620	597	578	562	555	
	6	967	960	962	959	962	964	962	961	957	957	962	899	849	801	731	687	657	627	604	585	568	562	
	7	969	966	959	964	964	963	957	954	957	964	965	896	842	806	734	690	654	628	604	583	567	561	
	8	969	925	961	951	951	952	958	954	952	950	941	872	838	809	736	688	652	630	605	586	566	562	
	9	959	965	966	917	946	949	960	957	965	956	901	844	836	779	716	676	648	623	601	580	564	558	
40	1	970	958	964	956	961	963	961	953	952	911	854	812	776	746	719	698	676	660	644	631	0	613	443
	2	967	963	961	957	954	952	946	955	955	955	948	911	837	781	735	701	669	646	623	606	589	584	
	3	968	962	959	952	954	956	956	953	953	958	955	949	916	831	770	711	676	648	625	602	583	578	
	4	969	962	962	959	956	961	952	959	959	952	961	942	919	829	768	715	675	646	621	599	581	575	
	5	969	958	961	955	963	956	954	959	959	952	962	955	929	834	767	714	676	644	618	599	580	573	
	6	968	960	962	959	962	963	961	959	955	956	962	954	931	844	777	723	687	652	626	604	587	580	
	7	969	965	958	963	963	962	954	952	955	963	964	956	907	825	763	716	676	648	623	601	584	578	
	8	969	925	961	951	949	951	957	953	951	948	939	917	844	783	736	699	664	643	620	603	586	582	
	9	958	964	964	916	944	948	958	952	959	943	878	824	784	749	719	693	671	651	632	615	604	599	

TABLE IV. - Continued. RADIATOR TUBE SURFACE TEMPERATURES

(b) Continued. SI Units

RUN	TUBE	DISTANCE FROM TUBE INLET TO THERMOCOUPLE, CM																				O-R		
		5	25	46	66	86	107	127	147	168	188	208	229	249	269	290	310	330	351	371	391		411	432
		TEMPERATURES, DEGREES KELVIN																						
41	1	971	960	967	959	964	966	963	956	962	930	852	792	752	721	691	665	642	625	609	594	0	575	426
	2	968	964	963	959	957	954	948	958	953	958	951	837	776	735	697	666	638	617	596	581	557	559	
	3	968	963	961	954	956	959	958	955	956	960	957	933	831	758	719	674	641	619	599	578	560	557	
	4	971	963	964	962	958	963	954	961	962	955	963	943	845	767	722	679	644	617	595	576	559	553	
	5	970	959	963	957	966	957	956	961	962	953	964	953	845	768	721	677	642	615	592	574	558	551	
	6	968	961	963	961	963	964	963	962	958	958	964	954	853	776	728	685	653	622	599	581	564	558	
	7	970	967	960	966	965	964	957	954	953	966	967	960	850	776	728	687	648	623	599	579	563	556	
	8	971	926	962	952	952	953	959	956	953	951	944	946	842	768	723	682	643	621	598	581	562	557	
	9	960	966	967	918	947	951	961	958	967	960	959	853	781	738	702	666	636	612	591	571	557	551	
42	1	973	962	968	961	966	967	966	955	947	915	874	816	760	727	698	673	649	632	616	601	0	583	425
	2	970	967	965	962	958	956	951	960	959	953	922	887	803	747	707	674	645	623	602	587	572	556	
	3	969	964	963	956	958	961	961	957	953	962	955	919	894	784	732	684	649	627	605	584	565	563	
	4	973	965	966	963	961	965	956	953	963	957	961	914	901	796	733	689	652	624	602	583	566	559	
	5	972	961	964	959	968	959	958	963	964	954	961	924	874	794	732	687	651	622	599	581	564	557	
	6	971	963	964	962	965	967	965	963	960	959	962	926	878	807	738	695	662	629	607	588	571	564	
	7	972	969	962	967	967	966	959	957	953	968	964	949	876	806	738	697	657	630	606	587	570	553	
	8	972	927	964	954	954	955	961	957	955	952	942	919	876	793	732	692	652	628	604	587	568	553	
	9	962	968	969	920	949	953	962	953	964	942	926	877	807	741	701	665	635	611	591	572	558	551	
43	1	969	958	964	956	961	963	961	953	959	918	864	813	771	738	709	686	662	644	627	612	0	593	435
	2	966	963	961	957	954	951	946	956	955	957	952	893	824	767	722	688	656	632	609	593	578	571	
	3	967	962	959	953	954	957	956	953	953	958	955	952	891	811	752	698	663	636	614	591	573	569	
	4	969	962	962	959	956	961	952	958	959	952	961	944	888	813	753	703	664	633	609	588	571	565	
	5	968	957	961	955	963	955	954	958	959	951	962	956	891	815	752	702	663	631	606	587	570	553	
	6	967	959	961	958	961	962	961	959	955	955	961	956	900	825	759	711	675	640	614	594	577	571	
	7	969	966	958	963	963	962	955	952	956	963	964	960	888	819	755	709	668	639	613	592	575	568	
	8	969	924	960	951	951	951	957	954	951	949	942	943	866	795	740	698	661	636	611	592	574	570	
	9	959	964	965	916	945	948	958	956	964	957	954	870	811	757	716	683	655	631	609	590	578	572	
44	1	971	959	964	957	962	963	961	954	960	959	909	837	794	760	728	701	675	656	637	620	0	598	434
	2	967	963	962	958	955	952	947	956	955	957	956	937	861	802	752	712	676	648	623	604	587	580	
	3	967	962	960	952	954	957	956	953	953	958	956	952	948	839	782	724	686	654	631	605	587	581	
	4	971	963	962	960	957	961	952	959	959	953	961	945	949	846	785	731	686	654	627	604	583	577	
	5	969	958	961	956	964	956	954	959	960	951	961	957	952	848	783	729	687	652	624	602	583	575	
	6	968	960	962	959	962	963	961	959	955	955	962	956	955	858	791	738	699	662	633	609	590	583	
	7	969	966	959	963	963	962	956	953	956	964	964	961	955	856	791	741	694	663	633	608	589	581	
	8	969	925	961	951	951	951	958	953	951	949	942	946	954	839	782	734	689	661	632	609	587	582	
	9	959	964	966	917	945	949	959	956	964	958	958	946	856	801	757	717	682	653	627	604	588	581	
45	1	967	954	959	951	956	958	955	949	955	956	930	868	824	789	758	729	701	679	659	641	0	621	444
	2	963	959	957	953	950	947	941	951	951	952	952	943	947	872	813	767	717	678	645	624	605	598	
	3	964	958	956	948	949	952	951	947	948	953	949	948	951	929	848	783	737	687	656	627	607	601	
	4	967	958	958	955	952	957	948	954	954	948	955	941	951	928	844	786	732	686	651	624	603	597	
	5	966	954	957	951	959	951	949	954	954	946	957	953	956	938	847	787	734	686	649	624	603	595	
	6	965	956	958	955	957	958	956	954	953	953	957	952	956	946	855	796	748	696	658	631	611	603	
	7	966	962	954	959	959	957	951	948	951	958	959	957	954	937	849	793	737	693	656	628	608	601	
	8	966	922	957	947	946	946	952	949	946	944	937	943	956	897	826	775	721	684	648	626	605	601	
	9	956	960	961	912	940	943	953	950	958	952	953	936	884	829	786	744	707	674	647	625	612	606	

46	1	968	957	962	954	959	961	958	952	958	953	918	856	806	771	739	709	682	663	646	629	0	608	433
	2	965	961	959	956	952	949	944	954	954	956	954	943	894	818	764	723	684	657	632	614	597	590	
	3	966	960	958	951	952	954	954	951	951	956	953	950	950	871	797	738	698	663	641	616	599	592	
	4	968	960	961	958	955	959	950	957	957	951	958	944	952	876	798	746	699	665	638	616	595	588	
	5	967	956	959	953	962	954	952	957	957	949	960	956	954	881	797	745	701	664	637	615	595	587	
	6	966	958	959	957	959	961	959	953	953	953	959	954	956	898	804	753	713	673	644	623	602	595	
	7	967	964	957	962	962	960	953	951	953	962	962	959	955	891	807	757	708	674	646	622	602	594	
	8	968	923	958	949	949	949	955	952	948	947	941	946	953	874	801	751	702	672	645	625	603	598	
	9	957	963	963	915	943	946	957	953	962	956	958	945	897	824	774	729	692	663	640	619	604	597	
47	1	967	954	959	952	956	958	956	949	954	957	954	941	861	777	744	717	688	663	642	625	0	606	432
	2	963	959	957	953	949	947	941	951	950	952	952	942	949	887	787	741	701	666	635	614	597	591	
	3	964	958	956	948	949	952	951	948	943	953	950	947	950	943	866	758	718	676	646	618	599	593	
	4	966	957	958	955	952	957	948	954	943	948	955	941	949	952	863	762	716	675	641	616	596	590	
	5	965	954	957	951	959	951	949	954	954	946	956	953	953	955	863	759	716	674	638	615	596	588	
	6	964	956	957	954	957	958	956	954	951	950	956	952	953	954	876	769	729	684	648	622	603	596	
	7	966	962	954	958	958	958	951	948	951	958	959	957	953	956	908	778	727	687	649	621	602	594	
	8	965	921	956	946	946	946	952	948	945	944	937	943	954	948	938	782	723	688	648	622	599	596	
	9	954	959	961	912	940	944	954	950	958	953	954	945	947	949	877	754	710	669	635	611	594	588	
48	1	971	958	963	954	958	960	957	951	956	958	958	948	905	851	811	774	740	715	692	670	0	643	446
	2	967	963	961	956	953	949	944	953	953	954	953	947	954	952	888	829	775	733	695	669	644	635	
	3	968	961	959	952	953	954	953	950	950	954	951	949	952	948	949	849	799	746	707	674	651	642	
	4	970	962	961	958	955	959	950	956	955	949	957	942	952	957	937	853	793	743	706	673	646	637	
	5	969	957	961	954	962	953	952	955	956	947	957	954	956	960	946	852	798	746	705	674	647	636	
	6	968	959	961	958	959	961	958	955	952	952	957	953	956	957	949	864	816	757	716	684	657	647	
	7	969	966	958	963	962	960	953	950	952	960	960	958	954	958	953	881	815	766	721	687	658	647	
	8	969	924	960	951	949	949	954	951	943	946	939	944	956	951	949	894	813	769	723	691	659	551	
	9	958	964	964	916	944	947	956	953	961	954	957	949	951	953	949	846	791	745	706	673	648	639	
49	1	968	955	960	952	956	958	956	949	955	956	953	927	878	832	790	756	726	703	681	661	0	635	445
	2	964	960	958	954	951	948	942	951	951	953	952	944	951	943	877	803	747	709	676	653	630	622	
	3	966	959	957	949	950	952	952	948	949	953	950	948	949	942	913	827	767	719	688	658	636	627	
	4	968	959	958	956	953	957	949	954	954	948	955	941	951	951	911	832	764	720	687	657	631	623	
	5	966	954	958	952	959	951	950	954	955	946	956	953	954	955	917	835	768	722	686	657	631	621	
	6	966	957	958	956	957	958	957	954	951	951	957	952	955	954	921	848	783	732	695	666	641	631	
	7	967	963	956	960	959	958	951	943	951	959	959	957	954	953	921	858	781	736	697	666	640	630	
	8	967	922	958	948	947	947	953	949	946	945	938	943	954	946	916	850	773	733	696	667	639	632	
	9	956	961	962	913	941	944	954	951	959	953	954	944	933	919	864	801	751	714	683	656	637	629	
50	1	1005	992	1001	989	994	916	852	808	755	713	681	653	630	612	594	580	565	553	541	530	0	516	374
	2	1001	997	993	896	837	737	670	641	614	591	568	548	531	516	503	492	482	473	465	458	453	450	
	3	1003	996	993	981	884	829	733	673	633	609	584	563	546	527	516	502	493	485	476	466	459	460	
	4	1006	997	994	993	930	851	780	709	662	625	599	572	553	538	523	509	497	487	478	470	463	461	
	5	1004	993	1000	992	1000	986	923	857	801	721	678	641	612	589	568	550	535	522	509	499	490	485	
	6	1003	996	998	995	998	999	996	908	853	766	703	659	624	598	574	556	542	527	514	503	493	488	
	7	1005	1003	995	1002	1001	1000	991	914	862	779	708	660	621	595	572	554	537	524	511	499	489	481	
	8	1006	958	999	989	987	987	994	902	848	768	698	655	624	595	572	553	536	524	511	500	489	485	
	9	994	1002	1003	951	982	984	992	882	808	739	681	642	612	587	568	550	535	521	508	495	487	482	

TABLE IV. - Continued. RADIATOR TUBE SURFACE TEMPERATURES

		(b) Continued. SI Units																						
		DISTANCE FROM TUBE INLET TO THERMOCOUPLE, CM																						
RUN	TUBE	5	25	46	66	86	107	127	147	168	188	208	229	249	269	290	310	330	351	371	391	411	432	O-R
		TEMPERATURES, DEGREES KELVIN																						
51	1	1004	992	1002	991	999	999	993	905	798	751	715	682	654	632	609	592	576	563	551	538	0	524	375
	2	1001	999	998	994	991	983	889	775	725	588	653	623	601	581	563	549	534	523	511	502	494	491	
	3	1002	997	995	987	993	992	990	817	751	707	667	637	611	586	571	551	537	527	515	503	492	494	
	4	1005	997	996	997	998	999	988	983	812	748	702	659	628	601	576	559	541	526	514	504	494	491	
	5	1003	992	998	992	1002	992	992	997	995	830	754	698	657	624	595	571	552	536	521	511	500	496	
	6	1003	994	998	996	999	1001	999	997	992	832	772	712	669	634	604	580	562	542	528	517	506	501	
	7	1004	1002	994	1002	1002	1001	993	989	993	891	767	712	666	633	604	581	559	544	529	516	506	495	
	8	1005	958	998	988	988	988	997	988	985	849	746	701	666	631	604	581	561	548	531	519	507	503	
	9	993	1001	1002	950	981	985	997	988	885	776	722	683	651	622	600	580	564	550	536	522	511	504	
52	1	1006	994	1003	993	1001	1002	997	977	858	798	746	702	668	643	619	601	583	569	556	543	0	527	376
	2	1002	1001	999	996	993	988	940	825	754	702	662	628	604	585	566	551	536	524	512	503	494	491	
	3	1003	998	996	988	994	995	996	953	828	756	699	661	631	603	586	564	549	538	526	512	502	502	
	4	1007	998	996	998	999	1001	991	994	894	815	744	686	648	616	590	571	552	535	522	511	499	496	
	5	1005	994	1000	993	1003	994	993	993	1001	943	818	742	688	648	616	590	570	552	535	523	511	505	
	6	1004	996	999	997	1001	1002	1001	998	995	969	836	757	701	661	626	601	580	559	543	529	517	512	
	7	1006	1003	995	1003	1003	1003	994	990	995	976	830	757	698	659	626	601	578	561	543	528	517	507	
	8	1006	959	999	989	989	989	998	991	991	961	815	747	699	658	626	601	577	562	545	531	518	514	
	9	994	1002	1003	951	982	987	999	994	993	888	783	719	678	646	618	596	577	560	544	530	519	513	
53	1	1008	997	1006	992	996	994	977	927	851	787	746	712	682	658	634	616	598	584	571	559	0	544	395
	2	1006	1003	1002	997	990	984	976	951	873	793	744	705	675	647	621	602	583	569	554	543	533	529	
	3	1007	1000	999	991	995	993	988	963	905	801	741	699	666	633	611	587	570	559	546	531	518	519	
	4	1010	1001	998	1001	997	999	982	969	909	802	746	698	663	629	603	584	566	549	536	525	514	511	
	5	1009	997	1002	996	1006	994	988	982	941	821	756	709	668	634	606	584	567	551	536	524	513	509	
	6	1007	1000	1002	1000	1003	1004	998	987	955	867	776	722	679	643	612	591	574	556	541	529	518	513	
	7	1009	1007	998	1005	1005	1004	992	981	952	877	774	724	678	644	613	591	571	556	541	527	517	511	
	8	1010	963	1002	992	992	988	992	971	933	854	761	719	684	647	618	595	574	561	545	533	521	518	
	9	997	1005	1006	952	981	980	988	958	907	818	758	717	682	652	626	604	587	571	556	542	533	527	
54	1	1010	999	1007	997	1005	1006	1004	976	870	789	737	696	662	637	613	594	576	562	548	536	0	521	396
	2	1007	1004	1003	999	996	993	989	993	885	796	741	696	664	637	612	592	573	558	544	532	522	515	
	3	1008	1001	1000	992	998	999	1000	992	922	813	748	697	661	631	608	583	564	553	539	524	509	509	
	4	1011	1003	999	1002	999	1005	995	1000	991	823	758	697	658	624	596	574	553	534	519	507	495	491	
	5	1010	999	1003	998	1007	998	998	1002	1004	887	788	723	675	638	607	581	560	542	524	511	499	494	
	6	1008	1001	1003	1001	1004	1006	1005	1002	999	926	808	737	687	649	616	591	571	550	533	519	507	501	
	7	1010	1008	999	1007	1006	1006	998	994	999	939	805	736	683	647	616	591	568	551	534	518	507	498	
	8	1011	964	1003	993	993	994	1001	996	995	944	795	728	685	646	615	589	567	552	536	522	508	504	
	9	998	1006	1007	956	987	991	1002	997	999	887	768	709	668	635	608	586	567	550	536	522	511	504	
55	1	1008	997	1006	996	1003	1005	1003	987	883	802	741	694	659	633	608	589	571	557	544	532	0	517	398
	2	1006	1003	1002	998	994	992	988	992	894	806	742	693	660	632	607	588	569	555	541	530	519	514	
	3	1007	1000	998	991	996	998	998	987	882	784	716	671	638	609	590	568	552	541	528	514	502	503	
	4	1010	1002	999	1001	999	1003	994	995	873	774	704	652	619	592	569	552	535	520	508	499	489	485	
	5	1008	997	1002	996	1006	996	996	1001	1003	913	801	722	672	634	604	579	561	544	529	517	506	502	
	6	1008	999	1002	1000	1003	1005	1004	1001	998	943	823	739	686	647	615	591	572	552	537	524	513	508	
	7	1009	1007	998	1005	1005	1004	997	993	998	952	821	741	683	647	615	591	569	553	537	523	513	504	
	8	1009	963	1002	992	992	993	1000	994	993	942	819	741	691	648	617	592	568	554	537	525	512	508	
	9	997	1004	1006	954	985	989	1002	997	1003	907	797	724	676	639	611	587	567	550	535	521	511	504	

56	1	1008	997	1006	996	1003	1004	1003	989	897	811	756	708	673	648	623	604	586	571	556	544	0	528	397
	2	1006	1003	1002	998	995	992	988	995	913	920	759	709	675	648	623	603	583	568	553	541	530	525	
	3	1007	1001	998	991	997	998	998	991	963	840	767	708	670	639	618	593	572	562	547	532	518	518	
	4	1010	1002	998	1001	998	1004	993	999	1001	852	775	706	666	633	605	583	563	546	530	518	507	503	
	5	1008	997	1002	996	1005	996	996	1001	1003	943	818	743	689	653	622	596	575	557	540	527	515	510	
	6	1008	999	1001	999	1003	1004	1004	1001	997	972	839	759	703	664	631	606	586	564	548	535	523	517	
	7	1009	1006	998	1006	1005	1005	997	994	998	984	837	761	701	663	632	607	583	566	548	534	522	513	
	8	1009	963	1001	992	992	992	1000	993	993	979	826	757	706	663	633	607	583	567	549	535	522	517	
	9	998	1005	1006	954	985	989	1001	997	1004	914	799	736	687	653	626	602	581	563	547	531	520	514	
57	1	1009	998	1006	995	1003	1003	998	963	939	881	823	779	747	722	696	675	654	638	623	608	0	590	387
	2	1006	1003	1001	998	994	992	987	991	972	925	856	791	756	723	692	668	643	624	605	591	577	572	
	3	1006	1000	998	990	996	997	997	991	989	979	928	832	769	727	697	660	634	616	598	579	563	563	
	4	1009	1001	999	1001	999	1003	993	993	1001	934	968	865	791	742	703	667	637	613	592	575	561	555	
	5	1008	997	1002	995	1005	996	994	1001	1002	987	956	879	793	746	703	666	637	612	591	574	559	554	
	6	1008	999	1002	999	1003	1004	1003	1001	997	993	964	894	804	754	712	675	648	619	598	580	566	559	
	7	1009	1006	998	1004	1005	1004	996	993	998	1000	956	877	791	748	708	674	643	620	598	578	565	558	
	8	1009	962	1001	991	991	991	999	991	983	966	913	825	775	734	699	668	639	622	600	584	567	564	
	9	998	1005	1006	953	984	988	999	991	957	925	843	784	748	720	693	668	647	627	609	592	581	575	
58	1	1008	996	1004	994	1002	1002	997	980	931	902	847	802	763	731	702	679	656	639	622	607	0	588	386
	2	1004	1003	1001	997	993	991	986	993	977	954	886	822	778	735	698	671	645	625	605	590	577	572	
	3	1006	999	998	990	996	997	997	990	988	980	936	861	804	746	706	666	639	619	601	582	567	565	
	4	1008	1001	998	1000	998	1003	992	998	999	987	923	874	823	762	714	676	646	620	598	579	564	559	
	5	1007	996	1002	994	1004	995	994	999	1000	985	943	901	825	763	713	675	645	618	596	579	564	558	
	6	1006	998	1000	998	1002	1003	1003	999	996	991	962	917	836	777	722	683	656	626	603	585	570	564	
	7	1008	1006	997	1004	1004	1003	996	992	997	1000	961	909	825	770	720	683	651	626	603	583	569	552	
	8	1008	962	1001	991	991	991	999	991	991	976	929	862	810	755	712	679	648	627	603	587	570	567	
	9	997	1004	1005	952	983	987	997	991	983	949	882	823	776	737	704	677	652	630	610	591	578	573	
59	1	1007	996	1004	993	1001	1003	999	984	953	876	826	783	746	717	691	669	648	633	618	603	0	585	385
	2	1004	1002	1001	997	992	991	986	993	985	947	857	798	756	717	686	661	638	620	601	587	573	558	
	3	1006	999	997	989	995	997	997	991	990	986	914	833	777	727	692	656	631	614	597	578	562	561	
	4	1008	999	998	999	999	1002	991	998	1000	991	974	850	797	742	700	663	635	612	592	575	559	554	
	5	1007	996	1001	994	1004	994	994	999	1001	988	974	864	800	745	700	662	634	610	589	573	558	552	
	6	1006	998	1000	998	1001	1003	1002	999	997	994	986	877	811	756	707	671	644	618	597	579	564	558	
	7	1007	1005	996	1003	1004	1002	995	992	996	1003	982	871	800	748	704	671	640	618	596	577	563	556	
	8	1008	961	1001	990	991	991	998	991	992	983	908	832	785	733	696	664	636	618	597	582	565	562	
	9	996	1004	1005	953	984	987	999	992	992	934	852	799	756	721	689	663	641	622	603	587	574	568	
60	1	1006	995	1003	993	1001	1002	1000	992	999	996	910	822	761	725	691	663	637	617	599	583	0	563	394
	2	1004	1001	999	996	992	989	984	995	995	991	922	825	765	725	691	662	634	614	594	579	565	559	
	3	1005	998	997	988	994	996	995	990	991	994	972	852	773	727	697	660	633	614	596	577	561	560	
	4	1007	999	996	998	995	1001	991	997	999	991	996	933	807	746	708	672	641	616	594	577	562	555	
	5	1006	994	999	993	1003	994	993	999	999	988	998	915	809	749	709	671	641	615	593	577	561	554	
	6	1006	998	999	998	1001	1002	1001	998	995	994	1000	944	828	761	717	681	652	623	601	583	568	551	
	7	1007	1004	996	1003	1002	1002	994	991	995	1003	1002	960	832	764	721	686	651	626	602	582	567	558	
	8	1007	961	999	989	989	990	997	992	990	988	979	978	864	776	730	692	654	630	605	587	567	553	
	9	995	1003	1004	952	983	987	998	995	1003	996	996	945	831	766	724	688	654	626	602	581	567	559	

TABLE IV. - Continued. RADIATOR TUBE SURFACE TEMPERATURES

		(b) Continued. SI Units																						
		DISTANCE FROM TUBE INLET TO THERMOCOUPLE, CM																						
RUN	TUBE	5	25	46	66	86	107	127	147	168	188	208	229	249	269	290	310	330	351	371	391	411	432	O-R
		TEMPERATURES, DEGREES KELVIN																						
61	1	1008	997	1004	994	1002	1003	1000	988	965	918	883	826	784	750	717	692	669	653	637	621	0	602	390
	2	1005	1002	1001	997	993	991	987	995	992	967	947	859	807	762	720	691	665	647	625	610	594	589	
	3	1006	999	997	990	996	997	997	991	992	994	975	946	853	788	742	693	667	644	626	604	587	584	
	4	1009	1000	998	999	998	1003	992	993	1001	993	998	916	882	806	754	706	671	646	623	603	586	579	
	5	1008	996	1001	994	1004	995	994	1000	1001	989	998	923	882	807	751	703	671	644	621	602	584	577	
	6	1007	999	1001	999	1002	1003	1002	999	997	995	998	928	892	816	758	711	681	652	629	609	592	584	
	7	1008	1006	997	1004	1004	1003	995	992	995	1004	999	926	882	811	756	711	676	653	628	607	591	584	
	8	1009	962	1001	991	991	991	998	992	992	986	942	906	863	796	746	704	671	652	628	611	591	588	
	9	997	1004	1005	953	983	988	999	994	1001	970	913	878	814	771	729	696	671	649	629	609	596	589	
62	1	1009	997	1004	993	1001	1003	999	993	993	990	958	908	857	818	782	752	723	702	683	666	0	647	388
	2	1006	1003	1001	997	992	991	986	996	995	997	995	973	948	887	824	773	731	701	673	654	636	629	
	3	1007	1000	998	990	995	996	996	991	991	997	994	991	987	947	881	801	752	709	681	655	636	630	
	4	1009	1001	998	1000	998	1003	992	998	999	992	999	985	990	954	880	811	753	711	682	656	635	628	
	5	1009	997	1002	994	1004	995	993	999	999	989	1001	996	991	956	876	805	752	711	679	656	634	625	
	6	1008	1000	1001	999	1002	1003	1002	999	995	995	1001	996	993	964	886	817	766	719	687	663	642	634	
	7	1009	1006	998	1004	1004	1003	994	992	995	1004	1004	1002	991	957	879	814	756	717	685	659	640	633	
	8	1009	962	1001	991	990	991	998	991	991	989	982	984	988	916	854	792	740	709	679	659	639	636	
	9	998	1004	1006	953	983	988	999	995	1002	995	994	958	912	866	811	763	729	702	677	656	643	637	
63	1	1008	996	1005	994	1002	1003	999	993	1001	1002	999	953	889	828	782	741	703	675	651	632	0	609	384
	2	1006	1002	1001	997	993	991	986	996	996	998	998	978	923	844	793	748	709	679	651	632	614	608	
	3	1006	999	998	990	994	996	996	991	992	997	995	991	987	869	813	756	718	682	658	633	614	610	
	4	1009	1001	998	1000	999	1003	991	998	999	993	1000	985	997	921	841	783	732	692	663	637	616	610	
	5	1008	996	1001	994	1004	995	993	999	1000	989	1002	997	997	921	839	779	732	692	661	637	616	608	
	6	1007	999	1001	999	1002	1003	1002	1000	995	996	1002	996	1001	946	851	792	747	702	670	644	624	616	
	7	1008	1006	997	1004	1004	1003	995	992	995	1005	1005	1002	999	971	861	802	749	709	674	645	625	618	
	8	1009	962	1001	991	991	991	998	992	991	989	982	988	999	964	881	811	756	717	678	652	626	622	
	9	997	1005	1006	953	984	988	999	996	1004	999	1001	993	993	937	851	795	746	702	666	638	619	611	
64	1	1002	989	997	987	994	996	993	986	992	993	978	962	904	841	790	751	717	692	669	648	0	621	391
	2	999	996	993	990	986	984	978	989	983	990	988	963	946	876	813	764	723	694	666	643	623	615	
	3	999	993	991	983	988	990	989	983	984	991	987	983	963	923	847	776	734	697	671	644	624	618	
	4	1003	994	991	993	990	995	984	991	992	986	993	978	979	949	868	798	744	706	677	649	626	619	
	5	1001	989	994	988	997	988	987	992	993	982	994	989	980	952	867	794	744	706	676	649	626	617	
	6	1000	993	994	992	994	996	995	992	983	988	994	989	987	959	880	809	759	716	684	658	634	625	
	7	1002	998	991	997	997	996	988	985	988	997	998	994	986	964	892	821	761	722	688	658	635	627	
	8	1002	956	993	984	983	984	991	984	984	982	974	981	988	963	911	831	766	728	691	664	637	631	
	9	990	998	998	947	977	981	992	989	997	991	992	982	966	918	878	811	756	714	680	650	630	619	
65	1	1010	998	1006	995	1002	1004	999	994	1001	1002	1002	987	901	846	803	767	731	702	675	653	0	628	383
	2	1007	1004	1002	999	994	992	987	998	997	999	998	987	972	889	828	781	739	704	673	651	632	625	
	3	1008	1002	999	992	996	998	998	992	993	998	997	993	996	951	874	799	756	712	682	654	635	629	
	4	1011	1002	1000	1001	1000	1003	992	999	1001	993	1001	987	999	978	890	821	767	722	688	658	636	629	
	5	1009	998	1003	996	1006	996	995	1001	1002	991	1002	998	999	978	887	817	767	723	686	658	636	627	
	6	1008	1001	1002	1000	1003	1004	1003	1001	997	997	1003	997	1002	996	899	829	782	733	696	666	643	635	
	7	1010	1007	999	1006	1005	1004	996	993	997	1006	1006	1003	999	999	912	841	784	741	700	667	644	637	
	8	1011	963	1002	992	992	992	999	993	993	990	983	990	1001	993	927	846	786	747	704	673	645	641	
	9	999	1006	1007	954	984	989	1001	997	1005	1000	1002	993	994	992	890	822	772	727	687	657	638	630	

66	1	1006	993	1001	989	996	998	994	989	995	998	998	974	922	878	826	784	751	728	711	693	0	672	377
	2	1002	999	997	993	988	986	981	992	991	993	992	984	991	973	905	842	784	742	708	687	665	657	
	3	1003	997	994	986	990	992	992	985	987	994	991	988	990	984	958	876	814	758	717	688	668	657	
	4	1006	997	994	996	996	998	987	994	995	988	995	982	993	994	958	892	814	758	723	694	672	665	
	5	1006	993	999	992	1001	992	989	995	995	985	997	993	993	998	958	890	817	760	721	696	673	664	
	6	1004	996	998	995	998	999	997	995	991	991	997	992	996	997	963	897	836	770	729	703	682	673	
	7	1006	1002	994	1001	999	999	991	987	991	1001	1000	998	994	997	968	902	828	771	730	702	682	674	
	8	1006	959	997	987	987	987	994	988	987	984	978	984	994	987	962	889	809	763	725	703	682	681	
	9	994	1002	1002	949	979	984	995	992	998	993	995	986	984	960	900	833	781	743	714	693	681	674	
67	1	1007	996	1004	993	1000	1002	997	992	998	1000	999	994	993	936	851	788	736	701	673	649	0	624	382
	2	1004	1002	1000	996	992	989	984	995	994	997	996	987	997	952	862	797	745	708	676	654	634	528	
	3	1006	999	997	989	993	995	996	989	990	996	994	991	993	979	896	812	760	713	684	657	638	632	
	4	1008	1000	997	999	998	1001	990	997	998	992	998	984	996	997	951	854	781	727	692	661	638	631	
	5	1007	996	1001	994	1003	993	992	998	998	988	999	997	996	1001	956	853	783	729	689	662	638	630	
	6	1006	998	1000	997	1001	1002	1001	998	994	994	1000	995	998	999	981	872	804	742	701	671	647	638	
	7	1007	1004	996	1003	1003	1002	993	991	994	1003	1003	1001	997	1001	991	888	808	753	708	673	649	641	
	8	1008	961	1000	990	989	990	997	991	993	988	981	988	997	993	991	917	824	768	716	681	651	645	
	9	996	1004	1004	952	983	987	998	995	1002	997	999	991	992	995	986	882	806	746	699	663	641	631	
68	1	1007	994	1002	991	998	1000	996	991	997	999	996	959	924	879	838	805	770	742	717	693	0	658	379
	2	1004	1001	999	995	991	988	982	993	993	994	994	984	989	970	897	842	795	757	719	693	669	662	
	3	1005	998	996	988	991	993	993	987	983	995	992	989	991	982	961	868	819	773	731	697	676	664	
	4	1007	999	996	997	997	999	989	996	996	990	997	983	993	992	963	886	823	774	736	700	674	667	
	5	1007	994	1000	993	1002	993	991	997	997	987	998	995	994	994	966	882	825	777	734	702	674	665	
	6	1006	997	999	997	999	1001	999	997	993	992	998	993	996	993	952	895	841	787	744	711	683	673	
	7	1007	1004	995	1002	1002	1000	992	989	993	1002	1002	999	996	994	958	902	838	793	748	710	684	674	
	8	1008	960	999	989	988	988	996	989	988	986	979	986	996	987	979	890	830	794	747	714	683	678	
	9	996	1003	1003	951	981	985	996	993	999	996	996	988	987	981	916	859	814	772	733	701	679	671	
69	1	1006	994	1002	990	998	999	994	989	996	998	997	989	977	926	869	812	767	734	704	678	0	648	380
	2	1003	1000	998	994	989	988	982	993	992	994	993	984	993	974	913	836	779	741	705	679	655	647	
	3	1004	997	995	987	991	993	993	987	983	994	992	989	991	984	956	864	802	753	714	683	661	651	
	4	1007	998	996	997	997	999	988	995	996	989	996	983	993	996	969	900	818	762	726	689	662	654	
	5	1006	994	999	992	1001	992	991	996	997	986	998	994	994	998	969	897	821	766	724	692	663	653	
	6	1005	997	998	996	999	1001	998	996	992	991	998	993	996	997	980	914	843	778	735	701	673	662	
	7	1006	1003	994	1002	1001	999	991	998	992	1001	1001	999	994	998	991	934	849	789	742	703	675	664	
	8	1007	959	998	988	988	987	994	988	987	985	978	985	994	990	988	939	860	800	748	711	677	659	
	9	995	1002	1002	950	981	984	996	993	999	995	997	987	989	992	982	907	834	775	729	692	667	656	
70	1	1005	992	999	989	995	997	992	987	993	996	996	986	963	910	871	822	776	742	711	687	0	653	378
	2	1001	999	996	993	988	986	981	991	990	992	991	983	993	988	946	881	816	766	722	692	668	661	
	3	1002	996	994	986	989	991	992	984	985	992	989	987	988	986	988	908	851	792	738	699	677	663	
	4	1006	997	994	996	995	997	986	993	994	987	994	981	991	994	986	921	856	791	744	702	673	657	
	5	1004	992	997	991	999	989	988	993	994	983	995	993	992	997	988	917	859	794	742	703	674	665	
	6	1003	994	996	993	997	998	996	993	990	989	996	991	994	995	987	936	880	806	753	713	683	672	
	7	1005	1002	993	1000	999	998	990	986	990	999	999	997	993	997	991	949	887	818	759	712	682	672	
	8	1005	958	997	987	986	986	993	985	985	983	976	983	993	989	986	953	892	825	758	713	679	673	
	9	994	1001	1001	949	979	983	994	991	997	993	994	987	988	989	974	917	857	786	729	688	667	659	

TABLE IV. - Concluded. RADIATOR TUBE SURFACE TEMPERATURES

		(b) Concluded. SI Units																						
		DISTANCE FROM TJBE INLET TO THERMOCOUPLE, CM																						
RUN	TUBE	5	25	46	66	86	107	127	147	168	188	208	229	249	269	290	310	330	351	371	391	411	432	O-R
		TEMPERATURES, DEGREES KELVIN																						
71	1	1005	993	1001	990	997	999	994	989	996	996	996	977	920	879	859	841	787	734	699	673	0	648	381
	2	1003	999	997	993	989	987	982	993	992	994	993	982	985	934	882	863	795	742	700	673	652	647	
	3	1003	996	994	986	990	992	992	986	987	993	990	987	989	970	908	886	820	758	711	677	657	652	
	4	1006	997	994	996	995	998	987	994	995	988	996	982	993	987	922	879	844	774	724	684	658	653	
	5	1005	993	998	992	1000	991	990	995	995	986	997	994	993	989	924	876	848	777	722	685	659	652	
	6	1004	996	998	995	998	999	998	995	992	991	997	992	996	992	938	876	874	794	735	694	667	659	
	7	1005	1002	994	1000	1000	999	991	988	992	1001	1001	998	994	994	936	883	880	809	744	697	669	652	
	8	1005	958	997	987	987	987	994	987	987	984	978	984	993	983	939	878	851	827	758	707	671	665	
	9	994	1002	1002	949	979	984	995	992	999	994	996	984	983	968	903	871	869	799	732	687	662	654	
72	1	1008	998	1006	996	1003	1005	1003	990	882	833	744	696	659	632	606	586	568	553	539	526	0	510	399
	2	1006	1004	1002	998	995	992	988	993	881	799	740	691	658	629	604	586	566	552	537	525	515	509	
	3	1007	999	998	989	996	996	995	845	768	709	662	630	604	579	564	545	532	521	509	496	485	485	
	4	1011	709	598	579	574	572	573	577	543	513	489	468	457	449	444	434	428	423	419	415	414	419	
	5	1009	997	1002	996	1005	996	996	999	1001	865	776	709	662	628	601	577	558	542	526	514	503	497	
	6	1008	1000	1002	1000	1003	1005	1004	1001	993	936	816	739	686	647	615	591	573	552	537	523	511	505	
	7	1009	1007	998	1006	1006	1005	998	993	993	947	816	742	685	648	617	592	570	553	537	522	511	502	
	8	1010	963	1002	992	992	993	1000	994	994	972	821	748	698	652	621	594	571	556	537	524	510	506	
	9	998	1006	1006	954	986	990	1002	993	1007	958	818	745	689	648	617	592	571	552	535	519	508	501	
73	1	1000	988	996	987	994	996	993	986	992	992	941	848	775	740	711	685	657	636	617	600	0	582	400
	2	998	994	993	989	985	983	977	985	987	986	947	842	776	739	709	682	651	628	606	591	578	573	
	3	1001	995	993	985	989	988	927	700	635	594	549	524	513	499	492	482	473	465	455	446	443	441	
	4	1003	996	993	994	992	993	907	788	665	597	542	516	502	494	484	469	455	443	432	421	413	411	
	5	1000	988	993	987	996	987	986	991	992	981	993	983	872	774	737	704	666	631	603	587	573	568	
	6	999	991	993	990	993	995	994	991	988	987	994	986	907	800	752	721	686	646	618	598	584	578	
	7	1001	997	989	996	996	994	987	984	988	997	998	992	911	804	753	723	682	648	618	597	583	577	
	8	1001	954	992	983	982	983	990	985	983	981	974	979	944	811	756	721	681	650	619	600	582	581	
	9	989	996	997	946	977	981	992	988	997	991	993	980	895	784	738	706	671	639	613	592	579	573	
74	1	971	958	964	955	961	962	959	953	958	961	959	954	927	858	807	766	728	697	670	647	0	621	401
	2	963	962	959	954	951	949	942	952	953	954	954	946	948	869	811	765	723	692	662	641	621	613	
	3	971	611	564	551	534	514	514	515	499	494	492	490	486	479	466	446	435	426	416	414	419	436	
	4	976	968	967	966	962	776	633	595	550	538	521	536	499	498	499	490	479	469	461	453	447	447	
	5	970	958	962	956	963	955	953	958	958	949	958	956	956	961	911	824	768	721	682	651	626	616	
	6	968	960	961	959	961	962	961	958	954	954	960	956	958	959	932	846	792	739	698	666	641	630	
	7	970	966	959	964	963	962	954	952	954	963	963	961	957	961	950	862	795	748	704	668	642	632	
	8	970	926	962	952	951	952	957	952	950	948	942	948	959	954	952	899	816	769	718	681	648	640	
	9	959	965	966	917	945	949	958	955	963	958	959	952	953	956	954	879	809	754	706	666	640	628	
75	1	966	953	958	949	953	954	951	944	949	952	950	946	946	946	909	846	794	757	725	699	0	669	402
	2	963	957	954	948	944	942	934	944	944	946	945	938	946	948	944	873	808	763	722	694	669	659	
	3	968	615	564	554	549	549	559	563	537	517	503	498	494	498	499	478	461	448	436	431	433	459	
	4	972	964	962	963	960	966	957	962	899	772	703	657	627	602	583	567	551	535	521	508	497	495	
	5	965	953	956	949	957	948	946	951	950	941	949	947	947	952	948	946	889	813	757	717	686	674	
	6	964	955	956	953	954	956	953	951	946	946	951	947	949	951	946	944	912	828	772	730	699	687	
	7	966	961	953	958	956	955	947	943	945	954	954	952	947	952	946	949	942	858	792	740	707	695	
	8	966	921	956	945	944	944	949	945	942	941	933	939	949	945	943	941	936	906	819	765	720	711	
	9	955	961	961	912	939	942	952	948	956	949	950	943	944	948	946	947	951	874	800	744	708	693	

76	1	964	951	956	946	950	949	946	938	943	945	943	939	938	941	942	942	908	845	790	746	0	700	403
	2	967	955	952	946	942	937	931	939	939	940	939	931	939	942	940	939	932	860	796	751	714	700	
	3	970	733	595	562	550	548	552	567	548	542	538	537	535	537	548	536	528	516	497	479	468	495	
	4	966	954	952	951	947	950	940	946	944	937	943	929	938	943	941	943	941	907	837	774	731	716	
	5	964	951	954	947	953	944	942	946	945	936	944	941	941	947	942	940	943	938	862	797	746	729	
	6	963	953	953	950	951	952	949	946	941	941	945	941	943	945	939	940	947	938	877	808	758	739	
	7	964	959	952	956	954	952	944	941	947	949	949	946	942	946	940	943	942	945	928	841	783	759	
	8	964	919	954	943	943	942	946	941	938	936	928	933	943	939	937	935	930	942	937	880	805	784	
	9	953	958	958	910	936	939	947	943	951	944	944	937	937	941	938	940	943	941	918	834	779	754	
77	1	974	959	964	954	958	958	954	947	952	954	951	948	946	949	948	944	910	858	819	787	0	751	404
	2	972	966	963	958	952	948	939	949	948	949	947	939	948	952	949	948	943	909	841	803	766	753	
	3	979	974	973	965	889	761	691	651	612	592	575	563	554	546	548	542	535	531	524	515	503	519	
	4	976	966	962	961	957	960	948	955	953	945	952	938	947	951	948	951	947	938	867	816	777	769	
	5	974	961	964	956	963	954	951	954	953	943	952	949	949	954	949	948	952	947	892	836	794	783	
	6	977	963	963	959	961	961	958	955	949	949	954	949	952	953	948	949	956	946	939	848	811	797	
	7	974	969	961	965	963	961	953	949	951	958	957	956	949	955	948	952	949	953	943	849	813	799	
	8	974	928	963	952	951	950	955	950	946	944	936	942	952	947	945	943	937	949	937	854	808	803	
	9	963	968	967	917	944	947	956	952	959	952	952	945	946	949	946	949	951	939	862	814	786	773	

TABLE V. - CROSS-SECTIONAL TEMPERATURE PROFILES AT LOCATIONS A AND C

(a) U. S. Customary Units

Run	Thermocouple readings, °R										
	A-1	A-2	A-3	A-4	A-5	C-1	C-2	C-3	C-4	C-5	C-6
1	1647	1635	1645	1523	1450	1446	1455	1457	1449	1371	1314
2	1628	1614	1626	1507	1436	1611	1622	1626	1613	1511	1434
3	1641	1629	1639	1519	1447	1638	1635	1639	1625	1523	1445
4	1654	1639	1650	1528	1455	1633	1645	1649	1636	1530	1452
5	1646	1632	1643	1522	1450	1626	1638	1643	1629	1525	1447
6	1628	1616	1625	1508	1439	1607	1617	1621	1608	1507	1431
7	1621	1607	1616	1501	1433	1596	1606	1609	1597	1498	1423
8	1638	1625	1636	1515	1445	1610	1623	1625	1614	1512	1437
9	1616	1602	1611	1497	1430	1573	1584	1585	1574	1479	1408
10	1605	1593	1602	1489	1424	1545	1556	1557	1547	1458	1389
11	1614	1602	1611	1497	1429	1556	1566	1569	1557	1466	1397
12	1740	1724	1738	1594	1512	998	1001	1001	999	978	963
13	1743	1728	1741	1596	1514	1187	1192	1198	1190	1150	1118
14	1759	1744	1757	1609	1525	1311	1318	1324	1314	1258	1216
15	1756	1742	1755	1607	1524	1465	1475	1476	1467	1390	1333
16	1749	1734	1747	1602	1519	1506	1516	1516	1509	1423	1360
17	1743	1728	1741	1597	1515	1721	1734	1743	1723	1597	1505
18	1741	1726	1737	1595	1515	1717	1730	1739	1719	1595	1504
19	1748	1733	1743	1600	1521	1721	1735	1743	1722	1599	1509
20	1739	1725	1735	1594	1515	1705	1718	1727	1708	1587	1499
21	1739	1724	1734	1594	1515	1699	1713	1722	1702	1583	1496
22	1738	1723	1733	1593	1514	1693	1705	1714	1696	1577	1491
23	1737	1723	1733	1594	1514	1693	1706	1714	1695	1578	1491
24	1752	1736	1747	1601	1519	1383	1393	1398	1387	1321	1272
25	1752	1736	1747	1603	1521	1488	1496	1498	1490	1414	1353
26	1751	1735	1746	1601	1520	1560	1570	1572	1563	1469	1401
27	1743	1727	1738	1596	1515	1621	1655	1660	1640	1524	1451
28	1743	1726	1738	1596	1515	1712	1724	1733	1712	1587	1494
29	1751	1735	1746	1602	1523	1723	1737	1746	1725	1597	1506
30	1742	1726	1737	1595	1514	1713	1726	1736	1716	1589	1500
31	1741	1725	1736	1594	1515	1714	1728	1736	1716	1592	1503
32	1741	1725	1735	1593	1514	1713	1727	1735	1714	1591	1500
33	1747	1731	1742	1599	1519	1718	1731	1740	1720	1597	1507
34	1741	1726	1737	1594	1515	1713	1727	1736	1715	1593	1502
35	1741	1725	1735	1595	1516	1712	1726	1734	1714	1593	1504
36	1744	1728	1740	1597	1516	1715	1729	1737	1717	1594	1503
37	1745	1729	1739	1598	1517	1716	1729	1738	1718	1595	1505
38	1743	1727	1738	1596	1517	1713	1727	1735	1716	1592	1504
39	1744	1728	1739	1595	1515	1715	1728	1736	1717	1593	1503
40	1744	1728	1737	1596	1516	1712	1725	1734	1714	1592	1503
41	1746	1730	1739	1598	1518	1716	1729	1738	1717	1595	1504
42	1750	1733	1744	1600	1519	1720	1734	1743	1722	1597	1506
43	1742	1728	1737	1596	1516	1712	1725	1734	1714	1592	1503
44	1744	1729	1739	1596	1517	1712	1726	1734	1714	1592	1504
45	1737	1722	1732	1592	1513	1704	1716	1724	1705	1585	1497
46	1741	1725	1735	1594	1515	1708	1721	1730	1709	1589	1500
47	1737	1721	1732	1591	1512	1704	1716	1724	1705	1585	1497
48	1744	1728	1739	1596	1516	1706	1719	1728	1708	1588	1499
49	1739	1724	1734	1593	1513	1704	1717	1725	1706	1585	1497
50	1807	1790	1804	1646	1557	1526	1534	1538	1528	1439	1375
51	1805	1789	1804	1644	1557	1773	1785	1796	1776	1628	1529
52	1809	1792	1806	1647	1559	1783	1795	1806	1786	1645	1544
53	1817	1799	1812	1651	1562	1689	1708	1717	1698	1581	1496
54	1817	1800	1813	1653	1564	1792	1805	1816	1794	1652	1551
55	1814	1798	1811	1651	1563	1789	1803	1813	1791	1651	1550
56	1814	1798	1812	1651	1563	1788	1803	1813	1791	1651	1550
57	1813	1798	1811	1650	1562	1780	1796	1805	1785	1644	1545
58	1813	1797	1810	1650	1561	1784	1799	1807	1787	1646	1546
59	1812	1796	1810	1649	1562	1786	1800	1810	1789	1649	1549
60	1811	1794	1807	1648	1561	1783	1798	1808	1786	1648	1549
61	1813	1798	1811	1650	1562	1786	1801	1810	1790	1649	1550
62	1815	1799	1813	1651	1564	1784	1798	1808	1787	1649	1551
63	1814	1799	1811	1651	1564	1785	1799	1809	1788	1650	1551
64	1802	1787	1799	1642	1556	1771	1786	1796	1775	1640	1542
65	1817	1800	1814	1653	1566	1787	1800	1811	1791	1652	1552
66	1808	1792	1807	1647	1560	1776	1790	1800	1781	1643	1546
67	1811	1796	1810	1650	1564	1782	1796	1806	1786	1648	1549
68	1811	1795	1809	1650	1562	1779	1794	1802	1783	1646	1548
69	1809	1793	1807	1649	1562	1778	1792	1802	1782	1645	1547
70	1807	1791	1805	1646	1559	1775	1788	1799	1778	1642	1544
71	1808	1792	1805	1647	1559	1776	1791	1801	1781	1644	1546
72	1815	1799	1812	1650	1563	1790	1803	1815	1792	1652	1551
73	1799	1784	1796	1640	1553	1770	1785	1795	1774	1637	1539
74	1745	1731	1742	1600	1519	1710	1724	1733	1713	1592	1503
75	1737	1723	1733	1594	1515	1696	1710	1719	1699	1581	1494
76	1735	1720	1730	1592	1513	1688	1701	1709	1690	1576	1489
77	1753	1737	1748	1606	1526	1704	1716	1723	1705	1586	1498

TABLE V. - Concluded. CROSS-SECTIONAL TEMPERATURE PROFILES AT

LOCATIONS A AND C

(b) SI Units

Run	Thermocouple readings, °K										
	A-1	A-2	A-3	A-4	A-5	C-1	C-2	C-3	C-4	C-5	C-6
1	915	908	914	846	806	803	808	809	805	762	730
2	904	897	903	837	798	895	901	903	896	839	797
3	912	905	911	844	804	910	908	911	903	846	803
4	919	911	917	849	808	907	914	916	909	850	807
5	914	907	913	846	806	903	910	913	905	847	804
6	904	898	903	838	799	893	898	901	893	837	795
7	901	893	898	834	796	887	892	894	887	832	791
8	910	903	909	842	803	894	902	903	897	840	798
9	898	890	895	832	794	874	880	881	874	822	782
10	892	885	890	827	791	858	864	865	859	810	772
11	897	890	895	832	794	864	870	872	865	814	776
12	967	958	966	886	840	554	556	556	555	543	535
13	968	960	967	887	841	659	662	666	661	639	621
14	977	969	976	894	847	728	732	736	730	699	676
15	976	968	975	893	847	814	819	820	815	772	741
16	972	963	971	890	844	837	842	842	838	791	756
17	968	960	967	887	842	956	963	968	957	887	836
18	967	959	965	886	842	954	961	966	955	886	836
19	971	963	968	889	845	956	964	968	957	888	838
20	966	958	964	886	842	947	954	959	949	882	833
21	966	958	963	886	842	944	952	957	946	879	831
22	966	957	963	885	841	941	947	952	942	876	828
23	965	957	963	886	841	941	948	952	942	877	828
24	973	964	971	889	844	768	774	777	771	734	707
25	973	964	971	891	845	827	831	832	828	786	752
26	973	964	970	889	844	867	872	873	868	816	778
27	968	959	966	887	842	901	919	922	911	847	806
28	968	959	966	887	842	951	958	963	951	882	830
29	973	964	970	890	846	957	965	970	958	887	837
30	968	959	965	886	841	952	959	964	953	883	833
31	967	958	964	886	842	952	960	964	953	884	835
32	967	958	964	885	841	952	959	964	952	884	833
33	971	962	968	888	844	954	962	967	956	887	837
34	967	959	965	886	842	952	959	964	953	885	834
35	967	958	964	886	842	951	959	963	952	885	836
36	969	960	967	887	842	953	961	965	954	886	835
37	969	961	966	888	843	953	961	966	954	886	836
38	968	959	966	887	843	952	959	964	953	884	836
39	969	960	966	886	842	953	960	964	954	885	835
40	969	960	965	887	842	951	958	963	952	884	835
41	970	961	966	888	843	953	961	966	954	886	836
42	972	963	969	889	844	956	963	968	957	887	837
43	968	960	965	887	842	951	958	963	952	884	835
44	969	961	966	887	843	951	959	963	952	884	836
45	965	957	962	884	841	947	953	958	947	881	832
46	967	958	964	886	842	949	956	961	949	883	833
47	965	956	962	884	840	947	953	958	947	881	832
48	969	960	966	887	842	948	955	960	949	882	833
49	966	958	963	885	841	947	954	958	948	881	832
50	1004	994	1002	914	865	848	852	854	849	799	764
51	1003	994	1002	913	865	985	992	998	987	904	849
52	1005	996	1003	915	866	991	997	1003	992	914	858
53	1009	999	1007	917	868	938	949	954	943	878	831
54	1009	1000	1007	918	869	996	1003	1009	997	918	862
55	1008	999	1006	917	868	994	1002	1007	995	917	861
56	1008	999	1007	917	868	993	1002	1007	995	917	861
57	1007	999	1006	917	868	989	998	1003	992	913	858
58	1007	998	1006	917	867	991	999	1004	993	914	859
59	1007	998	1006	916	868	992	1000	1006	994	916	861
60	1006	997	1004	916	867	991	999	1004	992	916	861
61	1007	999	1006	917	868	992	1001	1006	994	916	861
62	1008	999	1007	917	869	991	999	1004	993	916	862
63	1008	999	1006	917	869	992	999	1005	993	917	862
64	1001	993	999	912	864	984	992	998	986	911	857
65	1009	1000	1008	918	870	993	1000	1006	995	918	862
66	1004	996	1004	915	867	987	994	1000	989	913	859
67	1006	998	1006	917	869	990	998	1003	992	916	861
68	1006	997	1005	917	868	988	997	1001	991	914	860
69	1005	996	1004	916	868	988	996	1001	990	914	859
70	1004	995	1003	914	866	986	993	999	988	912	858
71	1004	996	1003	915	866	987	995	1001	989	913	859
72	1008	999	1007	917	868	994	1002	1008	996	918	862
73	999	991	998	911	863	983	992	997	986	909	855
74	969	962	968	889	844	950	958	963	952	884	835
75	965	957	963	886	842	942	950	955	944	878	830
76	964	956	961	884	841	938	945	949	939	876	827
77	974	965	971	892	848	947	953	957	947	881	832

TABLE VI. - CROSS-SECTIONAL TEMPERATURE PROFILES AT LOCATION B

(a) U. S. Customary Units

Run	Thermocouple readings, °R										
	B-1	B-2	B-3	B-4	B-5	B-6	B-7	B-8	B-9	B-10	B-11
1	1426	1422	1412	1333	1279	1434	1423	1417	1374	1305	1281
2	1625	1615	1599	1487	1412	1621	1607	1602	1540	1447	1415
3	1636	1628	1614	1499	1424	1640	1623	1617	1554	1459	1426
4	1647	1638	1624	1508	1431	1650	1634	1627	1563	1467	1433
5	1640	1632	1617	1507	1426	1643	1627	1621	1558	1462	1429
6	1619	1611	1598	1486	1411	1622	1604	1602	1539	1447	1412
7	1608	1600	1587	1477	1404	1612	1594	1590	1530	1439	1406
8	1625	1615	1603	1490	1416	1628	1613	1606	1544	1451	1418
9	1585	1577	1564	1459	1389	1587	1571	1568	1510	1422	1391
10	1556	1549	1539	1437	1370	1561	1544	1541	1486	1402	1372
11	1567	1560	1548	1445	1377	1570	1554	1551	1494	1410	1379
12	995	993	991	968	951	996	993	992	979	959	952
13	1177	1172	1165	1125	1095	1180	1173	1170	1146	1110	1096
14	1780	1775	1266	1212	1173	1283	1275	1271	1239	1191	1174
15	1443	1435	1426	1345	1290	1447	1436	1430	1385	1317	1292
16	1469	1462	1451	1365	1306	1474	1462	1455	1408	1334	1307
17	1737	1723	1706	1568	1480	1734	1717	1709	1634	1522	1482
18	1733	1721	1705	1569	1481	1735	1715	1709	1634	1524	1484
19	1736	1726	1710	1573	1486	1740	1719	1715	1638	1527	1488
20	1719	1710	1694	1561	1477	1724	1705	1698	1625	1518	1479
21	1714	1705	1689	1558	1474	1719	1700	1693	1621	1514	1476
22	1707	1698	1683	1553	1469	1712	1693	1687	1615	1509	1471
23	1706	1697	1682	1553	1469	1711	1693	1686	1616	1510	1471
24	1419	1413	1404	1326	1273	1423	1410	1408	1365	1298	1275
25	1582	1575	1559	1451	1381	1588	1570	1565	1501	1414	1384
26	1724	1712	1689	1544	1457	1717	1692	1690	1613	1498	1459
27	1727	1716	1699	1565	1479	1728	1707	1704	1629	1519	1480
28	1733	1722	1707	1570	1483	1735	1715	1709	1635	1525	1484
29	1744	1732	1715	1577	1489	1745	1724	1720	1643	1531	1491
30	1730	1720	1703	1568	1481	1733	1712	1708	1633	1523	1483
31	1730	1719	1703	1567	1481	1733	1712	1707	1633	1523	1483
32	1729	1719	1703	1567	1480	1732	1711	1707	1632	1521	1482
33	1734	1723	1708	1571	1483	1737	1717	1712	1636	1525	1486
34	1728	1718	1702	1567	1481	1732	1712	1707	1632	1522	1482
35	1729	1717	1701	1568	1482	1731	1711	1707	1632	1523	1485
36	1729	1720	1704	1568	1481	1734	1713	1708	1634	1523	1484
37	1732	1721	1705	1569	1482	1735	1714	1710	1634	1525	1485
38	1729	1718	1703	1567	1482	1733	1711	1707	1632	1522	1483
39	1730	1720	1705	1568	1481	1733	1713	1708	1633	1522	1483
40	1727	1717	1701	1566	1480	1731	1710	1705	1631	1521	1482
41	1732	1721	1705	1569	1483	1735	1714	1709	1634	1524	1485
42	1737	1725	1709	1572	1484	1739	1718	1713	1637	1526	1486
43	1727	1717	1701	1567	1481	1732	1711	1706	1631	1522	1482
44	1728	1717	1702	1567	1482	1731	1711	1706	1631	1522	1483
45	1718	1708	1692	1560	1474	1722	1701	1697	1624	1515	1477
46	1724	1713	1697	1564	1478	1727	1706	1702	1627	1519	1480
47	1718	1707	1692	1560	1474	1722	1701	1697	1623	1516	1477
48	1722	1712	1696	1562	1477	1725	1704	1700	1626	1518	1479
49	1719	1709	1694	1560	1475	1723	1701	1697	1624	1515	1477
50	1444	1435	1425	1340	1281	1446	1434	1428	1382	1310	1284
51	1793	1777	1757	1600	1499	1790	1769	1761	1675	1547	1502
52	1802	1786	1769	1614	1517	1800	1781	1772	1688	1563	1519
53	1696	1685	1673	1544	1456	1701	1676	1672	1607	1498	1458
54	1808	1795	1776	1621	1524	1806	1785	1780	1696	1570	1525
55	1805	1791	1772	1617	1518	1802	1781	1776	1692	1566	1521
56	1805	1792	1774	1621	1525	1805	1783	1779	1695	1572	1528
57	1803	1792	1775	1622	1527	1807	1788	1779	1696	1572	1529
58	1801	1791	1772	1619	1524	1805	1786	1777	1692	1570	1527
59	1802	1791	1773	1621	1527	1806	1787	1778	1694	1570	1528
60	1800	1789	1771	1620	1526	1804	1783	1776	1693	1571	1527
61	1802	1791	1774	1621	1526	1807	1787	1778	1694	1571	1529
62	1800	1790	1772	1620	1526	1805	1786	1777	1694	1571	1529
63	1800	1790	1773	1621	1527	1806	1788	1779	1694	1571	1529
64	1787	1777	1760	1611	1519	1793	1773	1765	1683	1562	1521
65	1803	1791	1774	1623	1528	1808	1789	1779	1696	1573	1531
66	1792	1779	1765	1615	1522	1798	1780	1768	1687	1567	1524
67	1798	1786	1770	1620	1526	1803	1785	1774	1692	1571	1528
68	1795	1782	1767	1617	1524	1800	1782	1771	1690	1568	1526
69	1794	1782	1766	1616	1523	1799	1781	1770	1688	1567	1525
70	1789	1779	1762	1613	1520	1795	1778	1767	1684	1565	1524
71	1793	1781	1765	1616	1522	1799	1780	1769	1687	1566	1524
72	1803	1786	1765	1608	1506	1797	1773	1768	1684	1555	1507
73	1786	1771	1753	1601	1501	1789	1762	1757	1673	1549	1503
74	1725	1711	1694	1557	1465	1728	1703	1698	1623	1510	1467
75	1711	1700	1684	1553	1468	1715	1695	1688	1617	1510	1470
76	1701	1692	1677	1549	1467	1707	1687	1682	1611	1506	1469
77	1717	1707	1692	1561	1476	1722	1702	1697	1624	1517	1478

TABLE VI. - Concluded. CROSS-SECTIONAL TEMPERATURE PROFILES AT LOCATION B

(b) SI Units

Run	Thermocouple readings, °K										
	B-1	B-2	B-3	B-4	B-5	B-6	B-7	B-8	B-9	B-10	B-11
1	792	790	784	741	711	797	791	787	763	725	712
2	903	897	888	826	784	901	893	890	856	804	786
3	909	904	897	833	791	911	902	898	863	811	792
4	915	910	902	838	795	917	908	904	868	815	796
5	911	907	898	834	792	913	904	901	866	812	794
6	899	895	888	826	784	901	891	890	855	804	784
7	893	889	882	821	780	896	886	883	850	799	781
8	903	897	891	828	787	904	896	892	858	806	788
9	881	876	869	811	772	882	873	871	839	790	773
10	864	861	855	798	761	867	858	856	826	779	762
11	871	867	860	803	765	872	863	862	830	783	766
12	553	552	551	538	528	553	552	551	544	533	529
13	654	651	647	625	608	656	652	650	637	617	609
14	711	708	703	673	652	713	708	706	688	662	652
15	802	797	792	747	717	804	798	794	769	732	718
16	816	812	806	758	726	819	812	808	782	741	726
17	965	957	948	871	822	963	954	949	908	846	823
18	963	956	947	872	823	964	953	949	908	847	824
19	964	959	950	874	826	967	955	953	910	848	827
20	955	950	941	867	821	958	947	943	903	843	822
21	952	947	938	866	819	955	944	941	901	841	820
22	948	943	935	863	816	951	941	937	897	838	817
23	948	943	934	863	816	951	941	937	898	839	817
24	788	785	780	737	707	791	783	782	758	721	708
25	879	875	866	806	767	882	872	869	834	786	769
26	958	951	938	858	809	954	940	939	896	832	811
27	959	953	944	869	822	960	948	947	905	844	822
28	963	957	948	872	824	964	953	949	908	847	824
29	969	962	953	876	827	969	958	956	913	851	828
30	961	956	946	871	823	963	951	949	907	846	824
31	961	955	946	871	823	963	951	948	907	846	824
32	961	955	946	871	822	962	951	948	907	845	823
33	963	957	949	873	824	965	954	951	909	847	826
34	960	954	946	871	823	962	951	948	907	846	823
35	961	954	945	871	823	962	951	948	907	846	825
36	961	956	947	871	823	963	952	949	908	846	824
37	962	956	947	872	823	964	952	950	908	847	825
38	961	954	946	871	823	963	951	948	907	846	824
39	961	956	947	871	823	963	952	949	907	846	824
40	959	954	945	870	822	962	950	947	906	845	823
41	962	956	947	872	824	964	952	949	908	847	825
42	965	958	949	873	824	966	954	952	909	848	826
43	959	954	945	871	823	962	951	948	906	846	823
44	960	954	946	871	823	962	951	948	906	846	824
45	954	949	940	867	819	957	945	943	902	842	821
46	958	952	943	869	821	959	948	946	904	844	822
47	954	948	940	867	819	957	945	943	902	842	821
48	957	951	942	868	821	958	947	944	903	843	822
49	955	949	941	867	819	957	945	943	902	842	821
50	802	797	792	744	712	803	797	793	768	728	713
51	996	987	976	889	833	994	983	978	931	859	834
52	1001	992	983	897	843	1000	989	984	938	868	844
53	942	936	929	858	809	945	931	929	893	832	810
54	1004	997	987	901	847	1003	992	989	942	872	847
55	1003	995	984	898	843	1001	989	987	940	870	845
56	1003	996	986	901	847	1003	991	988	942	873	849
57	1002	996	986	901	848	1004	993	988	942	873	849
58	1001	995	984	899	847	1003	992	987	940	872	848
59	1001	995	985	901	848	1003	993	988	941	872	849
60	1000	994	984	900	848	1002	991	987	941	873	848
61	1001	995	986	901	848	1004	993	988	941	873	849
62	1000	994	984	900	848	1003	992	987	941	873	849
63	1000	994	985	901	848	1003	993	988	941	873	849
64	993	987	978	895	844	996	985	981	935	868	845
65	1002	995	986	902	849	1004	994	988	942	874	851
66	996	988	981	897	846	999	989	982	937	871	847
67	999	992	983	900	848	1002	992	986	940	873	849
68	997	990	982	898	847	1000	990	984	939	871	848
69	997	990	981	898	846	999	989	983	938	871	847
70	994	988	979	896	844	997	988	982	936	869	847
71	996	989	981	898	846	999	989	983	937	870	847
72	1002	992	981	893	837	998	985	982	936	864	837
73	992	984	974	889	834	994	979	976	929	861	835
74	958	951	941	865	814	960	946	943	902	839	815
75	951	944	936	863	816	953	942	938	898	839	817
76	945	940	932	861	815	948	937	934	895	837	816
77	954	948	940	867	820	957	946	943	902	843	821

TABLE VII. - TUBE CONDENSING LENGTHS

(a) U. S. Customary Units

Run	O-R	Tube condensing length, L_n , in.								L_T ,	L_m ,	$L_{max} - L_{min}$,	
		1	2	3	4	5	6	7	8	9 $\sum_{n=1}^9 L_n$, in.	$L_T/9$, in.	in.	
1	354	54	55	50	62	60	60	58	60	60	519	58	12
2	352	63	64	65	68	68	69	70	71	70	608	68	8
3	350	78	79	80	82	82	83	85	85	83	737	82	7
4	355	75	75	76	83	86	86	86	87	87	745	83	12
5	351	80	82	84	86	86	88	88	87	87	768	85	8
6	417	76	79	87	87	88	88	88	92	89	774	86	16
7	418	82	86	94	94	95	95	96	98	95	835	93	16
8	357	94	95	96	105	105	106	108	110	108	927	103	16
9	416	109	114	120	120	120	121	124	124	126	1078	120	17
10	414	126	129	136	134	135	137	142	142	136	1217	135	16
11	415	128	134	142	137	137	138	142	142	141	1241	138	14
12	365	31	23	25	28	36	36	39	39	34	291	32	16
13	364	41	35	37	40	46	48	48	49	50	394	44	15
14	363	44	36	40	43	52	53	53	54	53	428	48	18
15	361	45	40	44	47	56	58	57	57	54	458	51	18
16	362	49	42	46	50	60	59	58	58	58	480	53	18
17	360	54	53	55	64	68	70	70	70	63	567	63	17
18	413	63	64	57	73	73	75	76	76	76	633	70	19
19	412	79	79	79	87	87	88	90	94	89	772	86	15
20	409	106	109	112	116	117	119	118	119	119	1035	115	13
21	407	108	116	120	122	122	124	128	128	124	1092	121	20
22	406	114	128	135	131	133	135	136	138	132	1182	131	24
23	405	119	129	136	134	136	136	137	140	134	1201	133	21
24	421	30	30	37	37	43	52	47	46	38	360	40	22
25	422	44	44	56	53	62	61	60	54	45	479	53	18
26	423	48	49	55	61	64	64	64	57	48	510	57	16
27	439	45	54	62	70	70	71	70	63	52	557	62	26
28	430	52	60	71	76	76	76	74	68	56	579	64	24
29	424	54	58	67	71	72	73	73	72	57	597	66	19
30	440	54	68	77	80	80	81	79	69	56	654	73	26
31	429	59	68	79	82	82	82	82	76	68	678	75	23
32	438	52	66	75	80	81	80	78	72	61	645	72	28
33	441	58	72	87	86	87	86	85	75	64	700	78	29
34	437	61	74	83	83	86	86	85	78	68	704	78	25
35	428	68	78	87	88	88	88	87	86	75	745	83	20
36	442	55	74	87	86	87	88	86	77	63	703	78	33
37	427	66	77	88	86	87	88	86	84	76	738	82	22
38	436	67	78	90	88	89	90	88	82	74	746	83	23
39	431	64	74	88	88	85	85	86	84	77	731	81	24
40	443	67	85	95	94	94	94	92	86	72	779	87	28
41	426	72	80	88	88	90	91	92	92	84	777	86	20
42	425	67	76	87	86	86	91	87	84	72	736	82	24
43	435	71	86	94	94	94	94	94	91	84	802	89	23
44	434	78	87	96	96	96	97	96	96	91	833	93	19
45	444	79	100	104	103	104	105	104	99	87	885	98	26
46	433	78	95	99	99	99	100	100	96	91	857	95	22
47	432	84	98	101	106	104	106	106	107	102	914	102	23
48	446	95	110	113	112	112	115	118	119	116	1010	112	24
49	445	83	106	108	107	108	108	108	107	99	934	104	25
50	374	31	14	16	25	36	43	48	48	51	312	35	37
51	375	51	44	50	58	64	68	68	68	59	490	54	24
52	376	57	46	56	62	71	73	73	72	67	577	64	27
53	395	46	50	53	54	59	60	57	54	49	482	54	14
54	396	57	60	62	66	69	71	72	72	65	594	66	15
55	398	56	58	56	60	69	71	72	73	65	580	64	17
56	397	56	59	64	68	72	72	73	74	69	607	67	18
57	387	53	63	74	77	76	77	77	69	60	626	70	24
58	386	54	66	71	71	71	77	78	71	61	620	69	24
59	385	60	69	75	77	80	81	81	78	68	669	74	21
60	394	75	76	79	84	84	84	85	88	84	739	82	13
61	389	66	70	75	84	85	84	83	81	71	699	78	19
62	388	75	91	102	102	101	102	100	98	85	856	95	27
63	384	86	88	96	101	99	103	103	104	104	884	98	18
64	391	84	91	98	101	101	101	101	104	100	881	98	20
65	383	87	96	103	105	105	105	107	111	104	923	103	27
66	377	73	104	112	111	110	112	112	112	103	949	105	39
67	382	101	103	106	111	111	112	114	118	114	990	110	17
68	379	79	97	106	104	104	107	103	101	94	895	99	28
69	380	93	102	108	110	110	110	112	114	104	963	107	21
70	378	96	110	115	115	115	116	118	118	115	1018	113	22
71	381	83	99	103	101	107	106	107	108	99	913	101	25
72	399	57	58	50	2	67	71	72	73	71	521	58	71
73	400	80	80	46	45	89	92	92	96	89	709	79	51
74	401	95	97	2	33	110	112	113	117	114	793	88	115
75	402	111	116	2	63	126	128	132	136	134	948	105	134
76	403	127	133	2	136	141	141	146	151	144	1121	125	149
77	404	125	135	31	138	144	146	146	147	139	1151	128	116

TABLE VII. - Concluded. TUBE CONDENSING LENGTHS

(b) SI Units

Run	O-R	Tube condensing length, L_n , cm								L_T , $\sum_{n=1}^9 L_n$, cm	L_m , $L_T/9$, cm	$L_{max} - L_{min}$, cm	
		1	2	3	4	5	6	7	8				
1	354	137	140	127	157	152	152	147	152	152	1316	146	30
2	352	160	163	165	173	173	175	178	180	178	1545	171	20
3	350	198	201	203	208	208	211	216	216	211	1872	208	18
4	355	191	191	193	211	218	218	218	221	221	1882	209	30
5	351	203	208	213	218	218	224	224	221	221	1950	216	20
6	417	193	201	221	221	224	224	224	234	226	1968	218	41
7	418	208	218	239	239	241	241	244	249	241	2120	235	41
8	357	239	241	244	267	267	269	274	279	274	2354	261	41
9	416	277	290	305	305	305	307	315	315	320	2739	304	43
10	414	320	328	345	340	343	348	361	361	345	3091	343	41
11	415	325	340	361	348	348	351	361	361	359	3153	350	36
12	365	79	58	64	71	91	91	99	99	86	738	82	41
13	364	104	89	94	102	117	122	122	124	127	1001	111	38
14	363	112	91	102	109	132	135	135	137	135	1088	120	46
15	361	114	102	112	119	142	147	145	145	137	1163	129	46
16	362	124	107	117	127	152	150	147	147	147	1218	135	46
17	360	137	135	140	163	173	178	178	178	160	1442	160	43
18	413	160	163	145	185	185	191	193	193	193	1608	178	48
19	412	201	201	201	221	221	224	229	239	226	1963	218	38
20	409	269	277	284	295	297	302	300	302	302	2628	292	33
21	407	274	295	305	310	310	315	325	325	315	2774	308	51
22	406	290	325	343	333	338	343	345	351	335	3003	333	61
23	405	302	328	345	340	345	345	348	356	340	3049	338	53
24	421	76	76	94	94	109	132	119	117	97	914	101	56
25	422	112	112	142	135	157	155	152	137	114	1216	135	46
26	423	122	124	140	155	163	163	163	145	122	1297	144	41
27	439	114	137	157	178	178	180	178	160	132	1414	157	66
28	430	132	152	180	193	193	193	188	173	142	1546	171	61
29	424	137	147	170	180	183	185	185	183	145	1515	168	48
30	440	137	173	196	203	203	206	201	175	142	1636	181	66
31	429	150	173	201	208	208	208	208	193	173	1722	191	58
32	438	132	168	191	203	206	203	198	183	155	1639	182	71
33	441	147	183	221	218	221	218	216	191	163	1778	197	74
34	437	155	188	211	211	218	218	216	198	173	1788	198	64
35	428	173	198	221	224	224	224	221	218	191	1894	210	51
36	442	140	188	221	218	221	224	218	196	160	1786	198	84
37	427	168	196	224	218	221	224	218	213	193	1875	208	56
38	436	170	198	229	224	226	229	224	208	188	1896	210	58
39	431	163	188	224	224	216	216	218	213	196	1858	206	61
40	443	170	216	241	239	239	239	234	218	183	1979	219	71
41	426	183	203	224	224	229	231	234	234	213	1975	219	51
42	425	170	193	221	218	218	231	221	213	183	1868	207	61
43	435	180	218	239	239	239	239	239	231	213	2037	226	58
44	434	198	221	244	244	244	246	244	244	231	2116	235	48
45	444	201	254	264	262	264	267	264	251	221	2248	249	66
46	433	198	241	251	251	251	254	254	244	231	2175	241	56
47	432	213	249	257	269	264	269	269	272	259	2321	257	58
48	446	241	279	287	284	284	292	300	302	295	2564	284	61
49	445	211	269	274	272	274	274	274	272	251	2371	263	64
50	374	79	36	41	64	91	109	122	122	130	794	88	94
51	375	130	112	127	147	163	173	173	173	150	1348	149	61
52	376	145	117	142	157	180	185	185	183	170	1464	162	69
53	395	117	127	135	137	150	152	145	137	124	1224	136	36
54	396	145	152	157	168	175	180	183	183	165	1508	167	38
55	398	142	147	142	152	175	180	183	185	165	1471	163	43
56	397	142	150	163	173	183	183	185	188	175	1542	171	46
57	387	135	160	188	196	193	196	196	175	152	1591	176	61
58	386	137	168	180	180	180	196	198	180	155	1574	174	61
59	385	152	175	191	196	203	206	206	198	173	1700	188	53
60	394	191	193	201	213	213	213	216	224	213	1877	208	33
61	389	168	178	191	213	216	213	211	206	180	1776	197	48
62	388	191	231	259	259	257	259	254	249	216	2175	241	69
63	384	218	224	244	257	251	262	267	264	264	2246	249	46
64	391	213	231	249	257	257	257	257	264	254	2239	248	51
65	383	221	244	262	267	267	267	272	282	264	2346	260	69
66	377	185	264	284	282	279	284	284	284	267	2408	267	99
67	382	257	262	289	282	282	284	290	300	290	2516	279	43
68	379	201	246	269	264	264	272	262	257	239	2274	252	71
69	380	236	259	274	279	279	279	284	290	264	2444	271	53
70	378	244	279	292	292	292	295	300	300	292	2586	287	56
71	381	211	251	262	257	272	269	272	274	251	2319	257	64
72	399	145	147	127	5	170	180	183	185	180	1322	146	180
73	400	203	203	117	114	226	234	234	244	226	1801	200	130
74	401	241	246	5	84	279	284	287	297	290	2013	223	292
75	402	282	295	5	160	320	325	335	345	340	2407	267	340
76	403	323	338	5	345	358	358	371	384	366	2848	316	378
77	404	318	343	79	351	366	371	371	373	353	2925	325	295

TABLE VIII. - REDUCED EXPERIMENTAL DATA

(a) U. S. Customary Units

Run	$P_{i'}$ psia	$W_{k'}$ lb/hr	$W_{g,t'}$ lb/hr	$V_{g,t'}$ ft sec	x_i	x_t	T_{sat} °R	$T_{m,g'}$ °R	$T_{k70'}$ °R	$L_{T'}$ in.	$Q_{t'}$ Btu/hr	$q_{t'}$ Btu (hr)(ft ²)	ΔP psi	$\Delta P_{e'}$ psi	$VH_{t'}$ psi
1	6.6	231	164	248	0.85	0.71	1714	1708	756	519	142000	25100	0.2	-0.10	0.10
2	5.8	228	181	304	0.93	0.80	1690	1726	772	608	158000	23800	0.2	-0.17	0.13
3	6.7	277	229	332	0.95	0.83	1716	1733	858	737	199000	24700	0.5	-0.25	0.19
4	6.8	304	232	353	0.87	0.76	1718	1715	868	745	200000	24700	0.3	-0.16	0.20
5	6.6	289	236	356	0.93	0.82	1714	1720	871	768	205000	24500	0.4	-0.11	0.20
6	5.9	311	250	460	0.90	0.80	1694	1691	885	774	217000	25800	0.7	0.43	0.28
7	5.9	322	259	477	0.90	0.80	1694	1684	893	835	225000	24700	1.2	0.46	0.30
8	6.6	351	275	458	0.88	0.78	1714	1704	961	927	238000	23600	1.1	0.50	0.31
9	5.9	377	305	622	0.89	0.81	1694	1686	1016	1078	264000	22500	1.8	0.87	0.46
10	5.9	374	323	665	0.94	0.87	1694	1680	1128	1217	281000	21200	2.8	1.02	0.52
11	6.2	396	336	656	0.93	0.85	1700	1692	1154	1241	289000	21400	2.9	1.02	0.54
12	11.2	187	122	116	0.89	0.65	1805	1805	693	291	103000	32600	0.	-0.10	0.03
13	11.6	233	151	136	0.85	0.65	1812	1810	744	394	129000	30000	0.1	-0.02	0.05
14	12.7	268	176	148	0.84	0.66	1828	1825	777	428	166000	35700	0.1	0.03	0.06
15	12.5	314	194	165	0.77	0.62	1824	1821	814	458	166000	33200	0.1	0.08	0.08
16	11.9	291	198	178	0.84	0.68	1816	1812	800	480	169000	32400	-0.1	0.11	0.09
17	11.7	336	224	203	0.80	0.67	1812	1806	846	567	192000	31100	0.2	0.19	0.11
18	11.5	364	270	254	0.87	0.74	1808	1804	878	633	230000	31900	0.4	0.27	0.17
19	11.8	414	321	299	0.89	0.77	1812	1814	943	772	275000	32700	0.5	0.38	0.23
20	11.8	496	403	382	0.91	0.81	1812	1815	1106	1035	345000	30600	1.6	0.70	0.38
21	11.8	554	437	416	0.87	0.79	1812	1810	1188	1092	373000	31400	2.0	0.83	0.44
22	11.8	609	458	447	0.83	0.75	1812	1811	1284	1182	391000	30400	2.5	0.95	0.50
23	11.8	609	458	447	0.83	0.75	1812	1811	1273	1201	391000	29900	2.6	0.98	0.50
24	12.0	405	190	169	0.59	0.47	1816	1815	839	360	162000	41400	0.7	0.	0.08
25	12.0	404	223	200	0.67	0.55	1816	1815	858	479	190000	36500	0.5	0.05	0.11
26	12.2	404	239	211	0.71	0.59	1820	1815	869	510	204000	36700	0.3	0.11	0.12
27	11.7	575	246	223	0.51	0.43	1812	1808	960	557	210000	34600	1.0	0.19	0.13
28	11.6	490	260	242	0.63	0.53	1812	1808	931	579	222000	35300	0.9	0.21	0.15
29	12.3	411	261	230	0.75	0.63	1820	1817	886	597	223000	34200	0.6	0.16	0.15
30	11.8	576	273	247	0.55	0.47	1812	1808	981	654	233000	32800	0.9	0.25	0.16
31	11.6	483	283	265	0.68	0.59	1812	1807	948	678	242000	32800	0.6	0.27	0.18
32	11.6	507	287	269	0.66	0.57	1812	1806	966	645	246000	35000	0.8	0.25	0.19
33	12.1	584	298	269	0.59	0.51	1818	1814	1008	700	255000	33400	1.2	0.41	0.20
34	11.7	523	303	284	0.67	0.58	1812	1808	986	704	259000	33800	1.0	0.33	0.21
35	11.7	482	305	284	0.73	0.63	1812	1807	960	745	261000	32200	1.0	0.33	0.21
36	11.7	577	312	292	0.62	0.54	1812	1811	1014	703	267000	34800	1.3	0.40	0.22
37	11.6	490	320	301	0.75	0.65	1812	1812	978	738	274000	34000	0.8	0.43	0.23
38	11.8	522	322	300	0.70	0.62	1812	1811	1003	746	275000	33800	1.2	0.43	0.24
39	11.6	481	333	313	0.79	0.69	1812	1811	998	731	285000	35700	0.9	0.41	0.25
40	11.9	576	333	310	0.66	0.58	1816	1811	1040	779	285000	33500	1.3	0.51	0.25
41	11.6	481	334	311	0.79	0.70	1812	1812	990	777	286000	33800	0.9	0.21	0.25
42	12.2	493	340	303	0.78	0.69	1820	1817	998	736	289000	36100	1.2	0.21	0.25
43	11.7	515	344	322	0.76	0.67	1812	1810	1015	802	294000	33700	0.9	0.43	0.27
44	11.8	521	360	337	0.78	0.69	1812	1812	1034	833	308000	33900	1.5	0.52	0.30
45	11.7	571	369	350	0.73	0.65	1812	1806	1072	885	315000	32700	1.7	0.60	0.31
46	11.7	521	371	349	0.80	0.71	1812	1809	1058	857	317000	33900	1.5	0.52	0.32
47	11.7	571	374	356	0.81	0.72	1812	1806	1058	914	320000	32200	1.7	0.65	0.32
48	12.2	568	403	376	0.79	0.71	1820	1816	1142	1010	344000	31200	2.1	0.75	0.37
49	11.8	564	404	383	0.80	0.72	1812	1809	1116	934	345000	33900	2.1	0.67	0.38
50	16.2	400	182	125	0.60	0.45	1874	1874	857	312	154000	45400	-0.1	0.06	0.06
51	16.7	422	248	160	0.71	0.57	1880	1874	892	490	201000	37700	-0.1	0.10	0.09
52	16.7	424	263	176	0.76	0.62	1880	1878	908	577	222000	35400	0.2	0.17	0.11
53	17.4	473	265	168	0.69	0.56	1888	1893	926	482	224000	42700	0.3	0.06	0.11
54	17.7	435	282	177	0.79	0.65	1892	1887	894	594	239000	37000	0.7	0.06	0.12
55	17.4	421	284	180	0.82	0.68	1888	1884	900	580	242000	38300	0.4	0.06	0.13
56	17.5	437	295	186	0.81	0.68	1890	1885	918	607	251000	37900	0.4	0.10	0.13
57	17.4	574	318	206	0.66	0.55	1888	1885	1006	626	269000	39500	0.5	0.27	0.16
58	17.1	551	326	212	0.70	0.59	1886	1885	1010	620	275000	40800	0.6	0.30	0.17
59	17.1	551	328	213	0.70	0.59	1886	1883	999	669	277000	38000	0.6	0.30	0.17
60	17.2	494	364	236	0.86	0.74	1888	1881	998	739	308000	38300	0.9	0.25	0.21
61	17.6	568	366	232	0.75	0.64	1892	1886	1042	699	310000	40800	0.4	0.27	0.21
62	17.7	661	415	268	0.72	0.63	1892	1888	1128	856	351000	37600	1.1	0.48	0.27
63	17.4	567	417	271	0.87	0.76	1888	1886	1094	884	353000	36600	0.9	0.48	0.28
64	16.7	564	429	293	0.86	0.76	1880	1875	1108	881	363000	37800	1.5	0.41	0.31
65	17.7	592	432	280	0.83	0.73	1892	1889	1128	923	366000	36400	1.0	0.54	0.30
66	17.1	652	435	292	0.76	0.67	1886	1883	1194	949	368000	35600	1.4	0.65	0.31
67	17.7	569	444	287	0.88	0.78	1892	1886	1132	990	376000	34900	1.4	0.59	0.31
68	17.7	654	453	293	0.78	0.69	1892	1885	1193	895	384000	39400	1.7	0.60	0.32
69	17.1	607	460	308	0.85	0.76	1886	1883	1172	963	389000	37100	1.2	0.62	0.35
70	17.1	648	461	309	0.80	0.71	1886	1880	1193	1018	391000	35200	1.3	0.62	0.35
71	17.4	607	468	304	0.87	0.77	1888	1880	1174	913	397000	39900	1.1	0.54	0.35
72	17.4	377	261	186	0.85	0.69	1888	1885	892	521	221000	38900	0.4	0.08	0.13
73	16.5	472	368	253	0.90	0.78	1878	1871	998	709	311000	40300	1.1	0.37	0.23
74	12.2	454	327	335	0.82	0.72	1820	1815	1100	793	279000	32300	1.5	0.62	0.30
75	11.8	494	376	402	0.85	0.76	1812	1809	1192	948	322000	31200	2.1	0.79	0.42
76	11.8	541	420	450	0.86	0.78	1812	1809	1310	1121	359000	29400	3.1	0.75	0.52
77	13.1	623	453	398	0.81	0.73	1832	1831	1391	1151	387000	30900	3.4	0.89	0.44

TABLE VIII. - Concluded. REDUCED EXPERIMENTAL DATA

(b) SI Units

Run	P _t kN abs m ²	W _k kg hr	W _{g,t} kg hr	V _{g,t} m sec	x _i	x _t	T _{sat} °K	T _{m,g'} °K	T _{k70'} °K	L _{T'} cm	Q _t W	q _t W/m ²	ΔP, kN m ²	ΔP _e , kN m ²	VH _t , kN m ²
1	45.5	105	74	76	0.85	0.71	952	949	420	1318	41630	79300	1.1	-0.69	0.68
2	40.0	103	82	93	0.93	0.80	939	959	429	1544	46150	75000	1.3	-1.17	0.92
3	46.2	126	104	101	0.95	0.83	953	963	477	1872	58150	78000	3.2	-1.72	1.28
4	46.9	138	105	108	0.87	0.76	954	953	482	1892	58670	77800	2.2	-1.10	1.38
5	45.5	131	107	109	0.93	0.82	952	956	484	1951	59980	77200	2.8	-0.76	1.41
6	40.7	141	113	140	0.90	0.80	941	939	492	1966	63620	81200	4.6	2.96	1.94
7	40.7	146	117	145	0.90	0.80	941	936	496	2121	65830	77900	8.1	3.17	2.08
8	45.5	159	125	140	0.88	0.78	952	947	534	2355	69760	74400	7.4	3.45	2.12
9	40.7	171	138	190	0.89	0.81	941	937	564	2738	77460	71000	12.6	6.00	3.20
10	40.7	170	147	203	0.94	0.87	941	933	627	3091	82720	66700	19.6	7.03	3.62
11	42.7	180	152	200	0.93	0.85	944	940	641	3152	84550	67300	19.9	7.03	3.71
12	77.2	85	55	35	0.89	0.65	1003	1003	385	739	30270	102800	0.	-0.69	0.23
13	80.0	106	68	41	0.85	0.65	1007	1006	413	1001	37730	94600	1.0	-0.14	0.34
14	87.6	122	80	45	0.84	0.66	1016	1014	432	1087	48740	112500	0.6	0.21	0.44
15	86.2	142	88	50	0.77	0.62	1013	1012	452	1163	48490	104600	0.9	0.55	0.54
16	82.0	132	90	54	0.84	0.68	1009	1007	444	1219	49630	102100	-0.7	0.76	0.59
17	80.7	152	102	62	0.80	0.67	1007	1003	470	1440	56230	98000	1.4	1.31	0.77
18	79.3	165	122	77	0.87	0.74	1004	1002	488	1608	67450	100500	2.9	1.86	1.15
19	81.4	188	146	91	0.89	0.77	1007	1008	524	1961	80450	103000	3.5	2.62	1.62
20	81.4	225	183	116	0.91	0.81	1007	1008	614	2629	101030	96400	11.0	4.83	2.59
21	81.4	251	198	127	0.87	0.79	1007	1006	660	2774	109330	98900	13.9	5.72	3.06
22	81.4	276	208	136	0.83	0.75	1007	1006	713	3002	114590	95800	17.4	6.55	3.45
23	81.4	276	208	136	0.83	0.75	1007	1006	707	3051	114490	94700	17.7	6.76	3.45
24	82.7	184	86	52	0.59	0.47	1009	1008	466	914	47500	130400	4.6	0.	0.54
25	82.7	183	101	61	0.67	0.55	1009	1008	477	1217	55770	115000	3.4	0.34	0.75
26	84.1	183	108	64	0.71	0.59	1011	1008	483	1295	59740	115700	2.3	0.76	0.85
27	80.7	261	112	68	0.51	0.43	1007	1004	533	1415	61480	109000	6.6	1.31	0.92
28	80.0	222	118	74	0.63	0.53	1007	1004	517	1471	65160	111200	5.9	1.45	1.06
29	84.8	186	118	70	0.75	0.63	1011	1009	492	1516	65160	107800	4.1	1.10	1.01
30	81.4	261	124	75	0.55	0.47	1007	1004	545	1661	68330	103200	6.4	1.72	1.14
31	80.0	219	128	81	0.68	0.59	1007	1004	527	1722	70970	103400	4.2	1.86	1.26
32	80.0	230	130	82	0.66	0.57	1007	1003	537	1638	72000	110300	5.6	1.72	1.30
33	83.4	265	135	82	0.59	0.51	1010	1008	560	1778	74550	105200	8.2	2.83	1.35
34	80.7	237	137	87	0.67	0.58	1007	1004	548	1788	75950	106600	7.2	2.28	1.45
35	80.7	219	138	87	0.73	0.63	1007	1004	533	1892	76490	101400	6.9	2.28	1.46
36	80.7	262	142	89	0.62	0.54	1007	1006	563	1786	78110	109800	9.2	2.76	1.54
37	80.0	222	145	92	0.75	0.65	1007	1007	543	1875	80160	107300	5.3	2.96	1.62
38	81.4	237	146	91	0.70	0.62	1007	1006	557	1895	80490	106600	8.1	2.96	1.63
39	80.0	218	151	95	0.79	0.69	1007	1006	554	1857	83370	112700	6.2	2.83	1.75
40	82.0	261	151	94	0.66	0.58	1009	1006	578	1979	83340	105700	9.1	3.52	1.74
41	80.0	218	151	95	0.79	0.70	1007	1007	550	1974	83810	106600	6.5	1.45	1.75
42	84.1	224	154	92	0.78	0.69	1011	1009	554	1869	84760	113800	8.0	1.45	1.74
43	80.7	234	156	98	0.76	0.67	1007	1006	564	2037	86130	106100	6.0	2.96	1.86
44	81.4	236	163	103	0.78	0.69	1007	1007	574	2116	90130	106900	10.1	3.59	2.04
45	80.7	259	167	107	0.73	0.65	1007	1003	596	2248	92290	103000	11.8	4.14	2.17
46	80.7	236	168	106	0.80	0.71	1007	1005	588	2177	92750	106900	10.1	3.59	2.18
47	80.7	236	170	109	0.81	0.72	1007	1003	588	2322	93820	101400	12.0	4.48	2.24
48	84.1	258	183	115	0.79	0.71	1011	1009	634	2565	100600	98400	14.3	5.17	2.55
49	81.4	256	183	117	0.80	0.72	1007	1005	620	2372	100980	106800	14.5	4.62	2.61
50	111.7	181	83	38	0.60	0.45	1041	1041	476	792	45220	143200	-0.7	0.41	0.39
51	115.1	191	112	49	0.71	0.57	1044	1041	496	1245	58970	118900	-0.7	0.69	0.65
52	115.1	192	119	54	0.76	0.62	1044	1043	504	1466	65110	115500	1.3	1.17	0.78
53	120.0	215	120	51	0.69	0.56	1049	1052	514	1224	65680	134600	2.1	0.41	0.75
54	122.0	197	128	54	0.79	0.65	1051	1048	497	1509	70050	116500	4.8	0.41	0.84
55	120.0	191	129	55	0.82	0.68	1049	1047	500	1473	70860	120700	2.7	0.41	0.86
56	120.7	198	134	57	0.81	0.68	1050	1047	510	1542	73390	119500	2.8	0.69	0.92
57	120.0	260	144	63	0.66	0.55	1049	1047	559	1590	78860	124500	3.6	1.86	1.10
58	117.9	250	148	65	0.70	0.59	1048	1047	561	1575	80680	128600	4.1	2.07	1.17
59	117.9	250	149	65	0.70	0.59	1048	1046	555	1699	81170	119900	4.3	2.07	1.18
60	118.6	224	165	72	0.86	0.74	1049	1045	554	1877	90320	120800	6.2	1.72	1.45
61	121.3	258	166	71	0.75	0.64	1051	1048	579	1775	90880	128500	2.6	1.86	1.43
62	122.0	300	188	82	0.72	0.63	1051	1049	627	2174	102760	118600	7.7	3.31	1.87
63	120.0	248	189	83	0.87	0.76	1049	1048	608	2245	103350	115500	5.9	3.31	1.90
64	115.1	256	195	89	0.86	0.76	1044	1042	616	2238	106320	119200	10.5	2.83	2.12
65	122.0	269	196	85	0.83	0.73	1051	1049	627	2344	107200	114800	6.8	3.72	2.03
66	117.9	296	197	89	0.76	0.67	1048	1046	663	2410	107710	112100	9.9	4.48	2.14
67	122.0	258	201	87	0.88	0.78	1051	1048	629	2515	110150	109900	9.4	4.07	2.15
68	122.0	297	205	89	0.78	0.69	1051	1047	663	2273	112420	124100	11.9	4.14	2.23
69	117.9	275	209	94	0.85	0.76	1048	1046	651	2446	113990	117000	8.1	4.27	2.39
70	117.9	294	209	94	0.80	0.71	1048	1044	663	2586	114370	111000	9.0	4.27	2.40
71	120.0	275	212	93	0.87	0.77	1049	1044	652	2319	116230	125800	7.6	3.72	2.39
72	120.0	171	118	57	0.85	0.69	1049	1047	496	1323	64710	122700	2.4	0.55	0.92
73	113.8	214	167	77	0.90	0.78	1043	1039	554	1801	91200	127100	7.7	2.55	1.57
74	84.1	206	148	102	0.82	0.72	1011	1008	611	2014	81660	101800	10.1	4.27	2.07
75	81.4	224	171	123	0.85	0.76	1007	1005	662	2408	94320	98300	14.5	5.45	2.87
76	81.4	245	191	137	0.86	0.78	1007	1005	728	2847	105110	92700	21.4	5.17	3.58
77	90.3	283	205	121	0.81	0.73	1018	1017	773	2924	113300	97300	23.4	6.14	3.03

TABLE IX. - VARIATION OF OPERATING CONDITIONS

Run	O-R	Flow variation			P_i variation			P_o variation			L_m variation		
		Δ , $\frac{\text{lb}}{\text{hr}}$	Δ , $\frac{\text{kg}}{\text{hr}}$	$\frac{100 \Delta}{W_k}$, %	Δ , psi	Δ , $\frac{\text{kN}}{\text{m}^2}$	$\frac{100 \Delta}{P_i}$, %	Δ , psi	Δ , $\frac{\text{kN}}{\text{m}^2}$	$\frac{100 \Delta}{P_o}$, %	Δ , in.	Δ , cm	$\frac{100 \Delta}{L_m}$, %
1	354	21	10	9	0.	0.	0	0.	0.	0	0	0	0
2	352	35	16	15	0.	0.	0	0.2	1.2	3	0	0	0
3	350	62	28	22	0.	0.	0	0.5	3.2	7	0	0	0
4	355	37	17	12	0.	0.	0	0.	0.	0	0	0	0
5	351	49	22	16	0.	0.	0	0.	0.	0	0	0	0
6	417	28	13	9	0.0	0.3	0	0.7	5.2	14	0	0	0
7	418	28	13	9	0.	0.	0	1.2	8.6	26	0	0	0
8	357	95	43	27	0.	0.	0	0.	0.	0	0	0	0
9	416	73	33	17	0.0	0.3	0	0.3	2.3	8	0	0	0
10	414	0	0	0	0.0	0.3	0	0.	0.	0	0	0	0
11	415	0	0	0	0.	0.	0	0.1	0.6	2	0	0	0
12	365	19	9	10	0.	0.	0	0.	0.	0	0	0	0
13	364	7	3	3	0.	0.	0	0.	0.	0	0	0	0
14	363	12	5	4	0.	0.	0	0.	0.	0	0	0	0
15	361	2	1	1	0.	0.	0	0.	0.	0	0	0	0
16	362	12	5	4	0.1	0.8	1	0.1	0.6	1	0	0	0
17	360	9	4	3	0.1	0.6	0	0.0	0.3	0	2	5	3
18	413	30	14	8	0.1	0.8	1	1.1	7.4	10	0	0	0
19	412	39	18	9	0.2	1.2	1	0.1	0.6	1	0	0	0
20	409	36	16	7	0.2	1.4	1	0.1	0.9	1	3	8	3
21	407	52	24	10	0.6	4.0	5	0.4	2.9	4	6	15	5
22	406	63	29	11	0.7	4.6	5	0.7	4.9	8	3	8	2
23	405	91	41	14	0.1	0.6	0	0.7	5.2	8	3	8	2
24	421	42	19	10	1.0	7.2	8	1.2	8.1	10	9	23	22
25	422	25	11	6	0.6	4.0	4	0.9	6.3	8	8	20	16
26	423	28	13	7	0.0	0.3	0	0.6	4.0	5	2	5	3
27	439	51	23	9	0.2	1.4	1	0.6	4.3	6	5	13	8
28	430	69	31	14	0.2	1.4	1	1.1	7.4	10	5	13	8
29	424	30	14	7	0.2	1.7	2	0.5	3.2	4	2	5	3
30	440	80	36	14	0.1	0.6	0	0.2	1.7	2	5	13	6
31	429	53	24	11	0.2	1.2	1	0.3	2.3	3	7	18	10
32	438	64	29	12	0.1	0.6	0	0.2	1.4	2	3	8	4
33	441	96	44	16	0.1	0.8	1	0.1	0.6	1	3	8	4
34	437	78	35	16	0.3	2.0	2	0.2	1.7	2	5	13	6
35	428	58	26	12	0.3	2.3	2	0.7	4.9	7	5	13	6
36	442	115	52	20	0.4	2.9	3	0.5	3.2	4	2	5	3
37	427	57	26	12	0.2	1.7	2	1.0	7.2	10	8	20	9
38	436	76	34	14	0.2	1.2	1	0.2	1.2	2	3	8	4
39	431	44	20	9	0.1	0.6	0	0.7	4.6	6	7	18	9
40	443	133	60	23	0.2	1.4	1	0.6	4.3	6	5	13	6
41	426	50	23	11	0.2	1.4	1	0.8	5.8	8	4	10	5
42	425	41	19	8	0.1	0.8	1	0.7	4.9	6	10	25	12
43	435	60	27	11	0.2	1.4	1	0.2	1.4	2	4	10	5
44	434	55	25	11	0.3	2.0	2	0.5	3.7	5	5	13	5
45	444	123	56	21	0.1	0.6	0	0.2	1.2	2	2	5	2
46	433	73	33	14	0.4	2.6	3	0.1	0.9	1	4	10	4
47	432	71	32	14	0.2	1.6	2	0.2	1.4	2	9	23	9
48	446	134	61	24	0.2	1.2	1	0.2	1.7	3	4	10	4
49	445	112	51	19	0.3	2.0	2	0.3	2.0	3	7	18	7
50	374	19	9	5	0.3	2.0	1	0.2	1.2	1	17	43	48
51	375	28	13	7	0.	0.	0	0.	0.	0	6	15	10
52	376	37	17	9	0.	0.	0	0.	0.	0	2	5	4
53	395	134	61	30	4.2	28.7	24	4.4	30.3	26	12	30	22
54	396	37	17	8	0.7	5.2	4	0.7	4.6	4	2	5	3
55	398	28	13	7	0.6	4.0	3	0.6	4.3	4	1	3	1
56	397	46	21	11	0.8	5.7	4	1.0	7.2	6	1	3	2
57	387	122	55	21	2.2	14.9	12	2.3	16.1	14	7	18	11
58	386	138	63	25	2.6	17.8	15	2.8	19.6	17	10	25	15
59	385	117	53	21	1.6	10.9	10	1.1	7.5	7	4	10	6
60	394	48	22	10	0.5	3.4	3	0.5	3.4	3	6	15	7
61	389	62	28	11	0.	0.	0	0.	0.	0	10	25	13
62	388	55	25	8	0.	0.	0	0.	0.	0	6	15	7
63	384	30	14	5	1.0	6.6	5	0.9	6.3	6	2	5	2
64	391	112	51	20	1.6	11.2	10	1.2	8.1	8	8	20	8
65	383	46	21	8	1.0	6.6	5	0.6	4.0	4	2	5	2
66	377	68	31	10	0.	0.	0	0.	0.	0	2	5	2
67	382	48	22	8	1.6	11.2	9	1.0	6.9	6	1	3	1
68	379	70	32	11	0.7	5.2	4	1.2	8.3	8	18	46	18
69	380	66	30	11	1.7	11.4	10	1.2	8.3	8	10	25	9
70	378	59	27	9	0.	0.	0	0.	0.	0	6	15	5
71	381	84	38	14	1.7	12.1	10	1.8	12.4	11	10	25	10
72	399	23	10	6	0.7	4.6	3	0.6	4.0	3	0	0	0
73	400	53	24	11	0.7	4.9	4	0.5	3.7	4	3	8	4
74	401	46	21	10	0.7	5.2	6	0.6	4.3	6	0	0	0
75	402	45	20	9	0.0	0.3	0	0.4	2.6	4	0	0	0
76	403	61	28	11	0.2	1.2	1	0.7	4.9	8	0	0	0
77	404	135	61	21	1.5	10.0	11	0.5	3.2	5	8	20	6

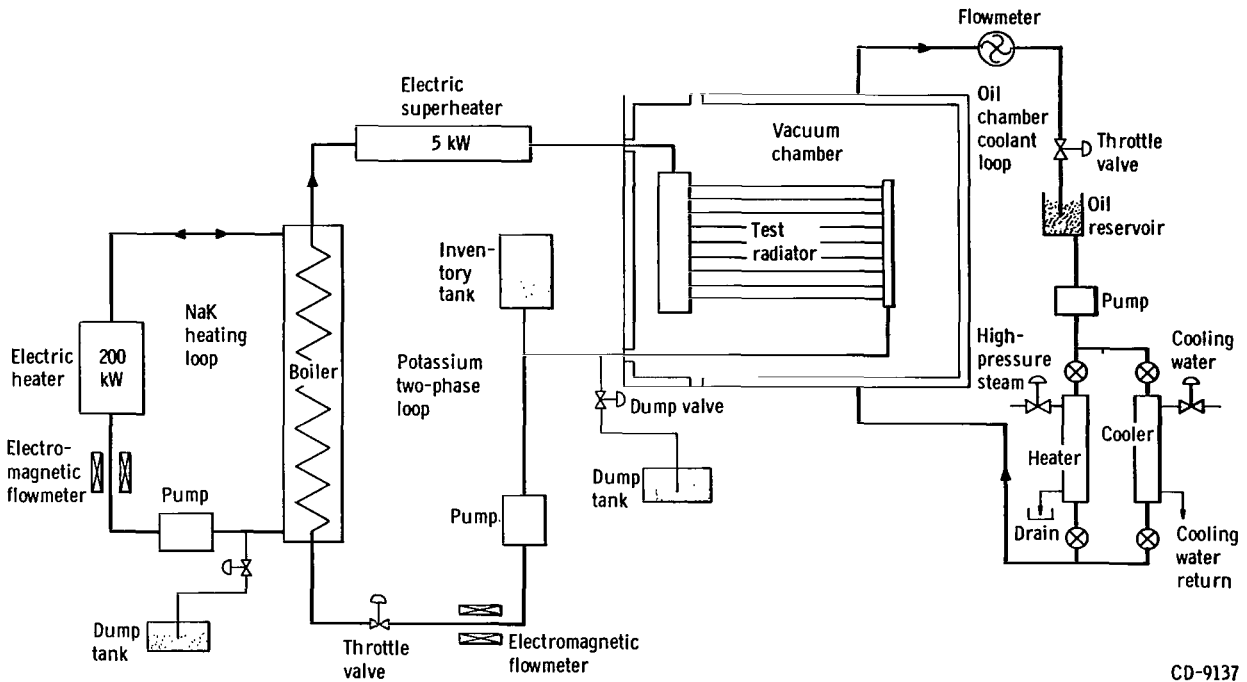

Figure 1. - Schematic diagram of test facility.

CD-9137

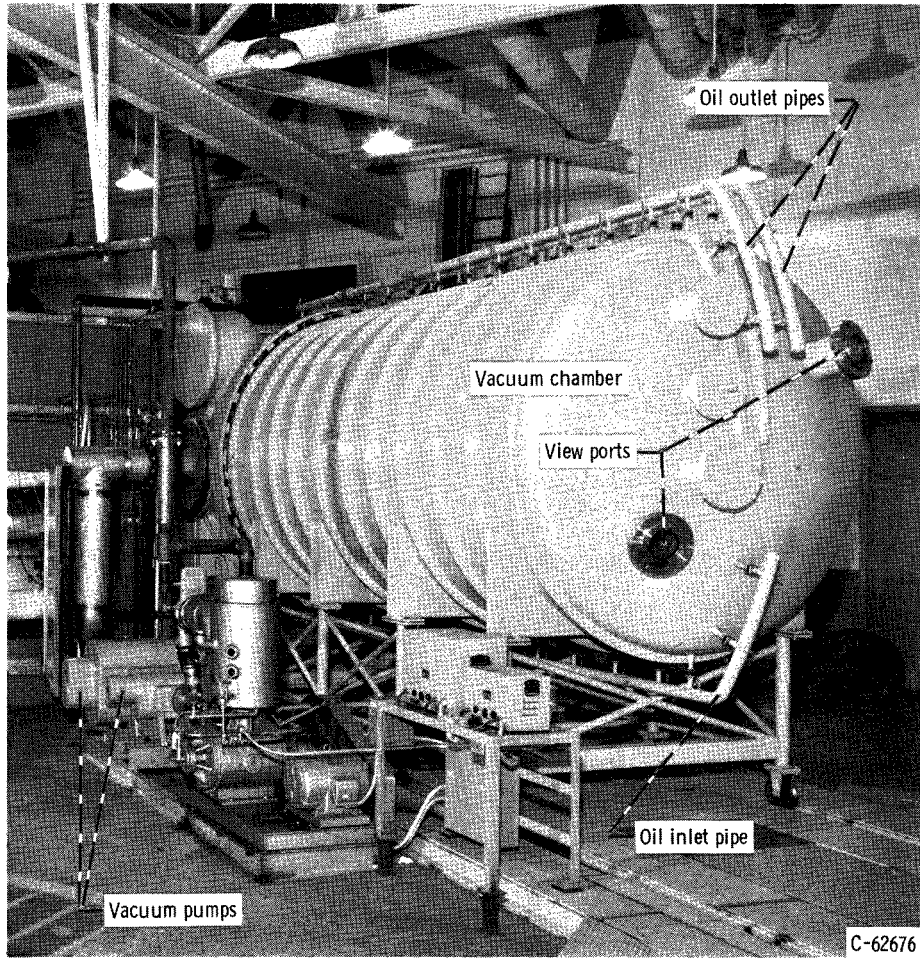
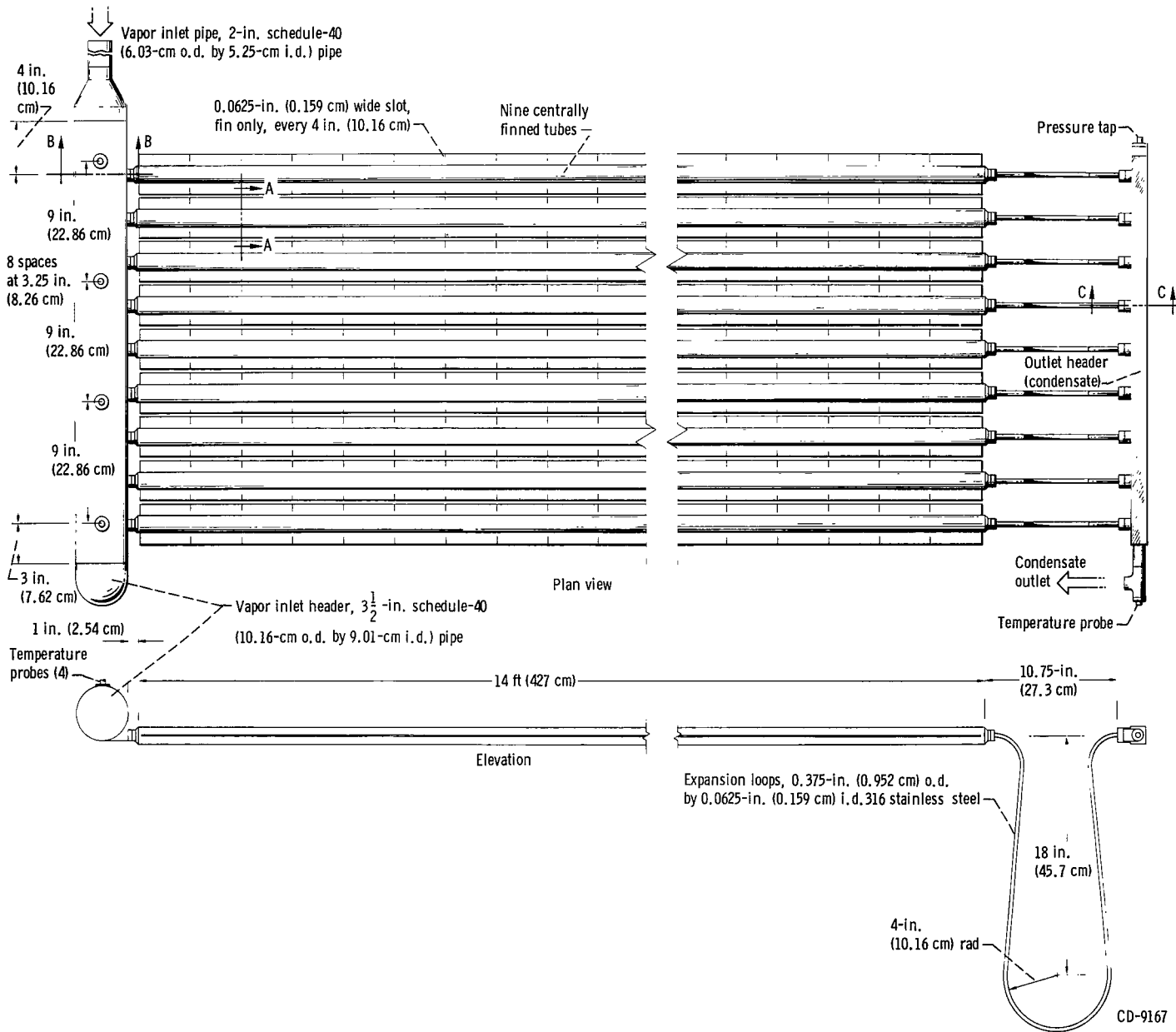
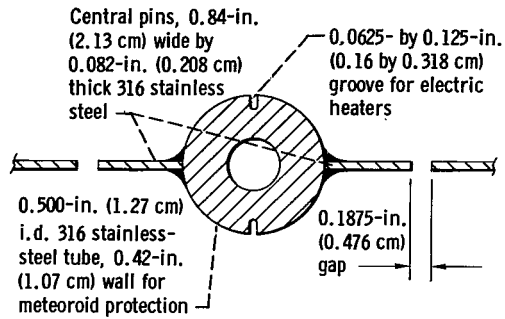

Figure 2. - Potassium condensing radiator test facility.



(a) Assembly.

Figure 3. - Multitube potassium condensing radiator.



Section A-A finned tube

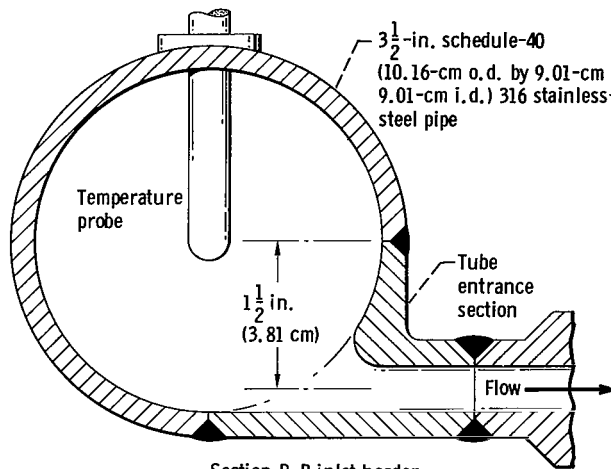

Section B-B inlet header

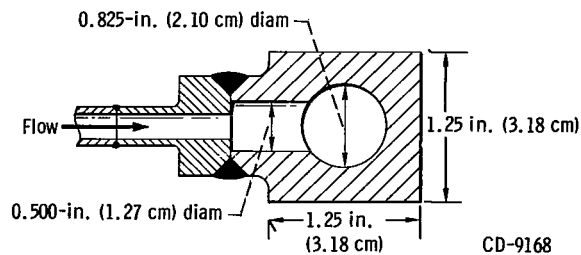

Section C-C outlet header

(b) Details.

Figure 3. - Concluded.

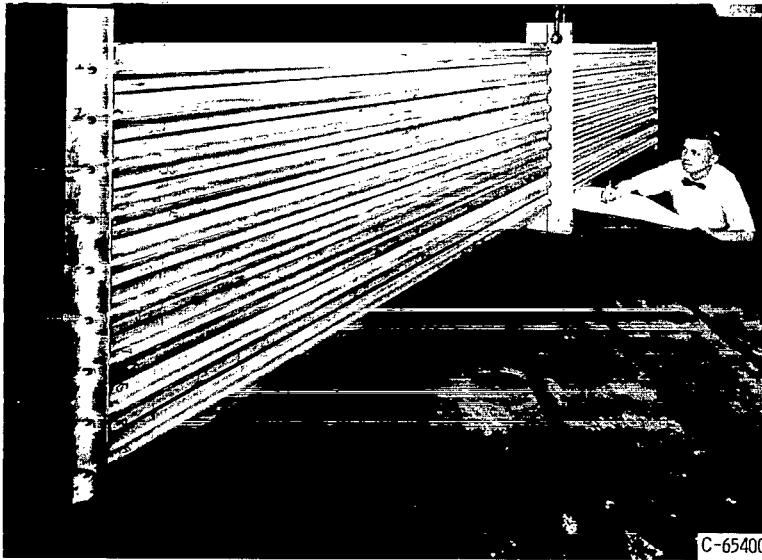

(a) Inlet header and tubes showing tube inlets during fabrication.

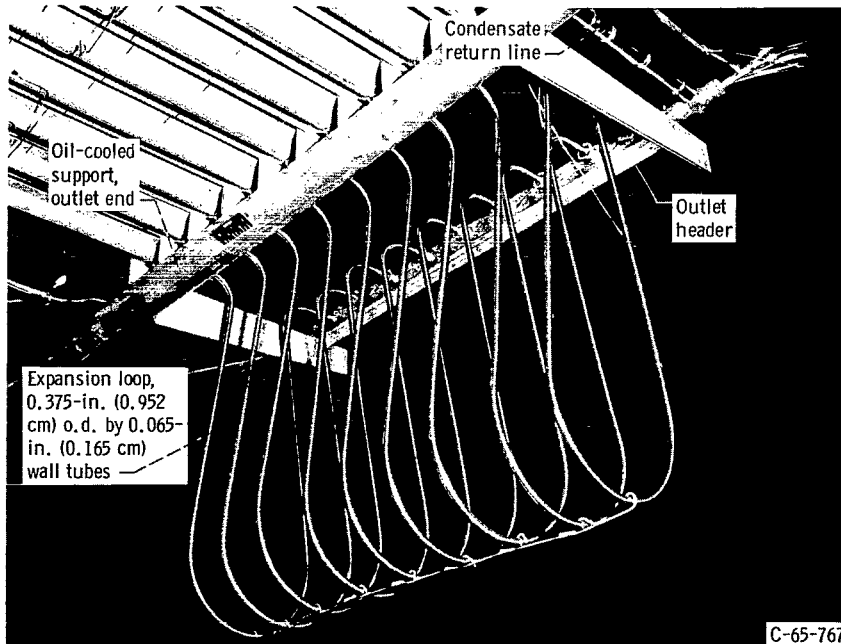

(b) Expansion loops and outlet header.

Figure 4. - Details of potassium condensing radiator.

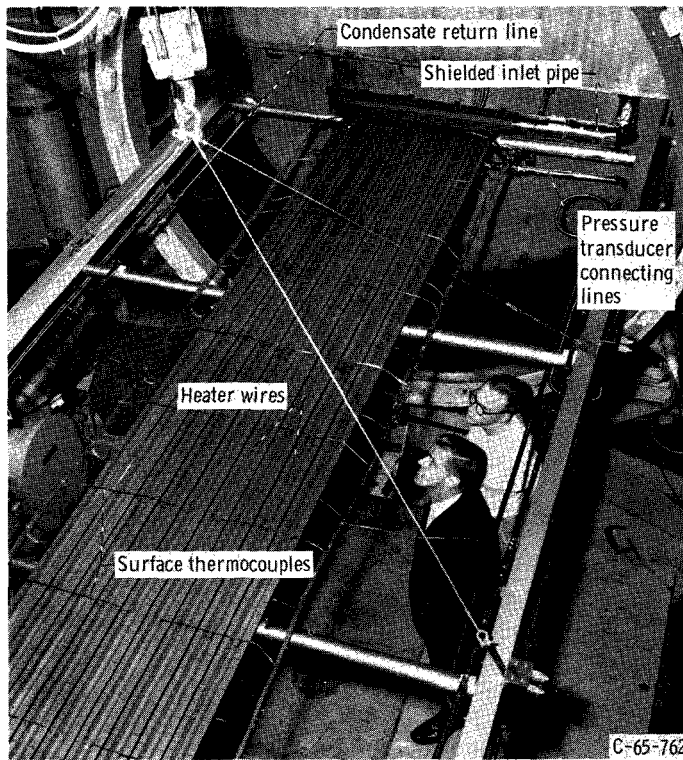

(c) Top view showing inlet header and instrumentation.

Figure 4. - Concluded.

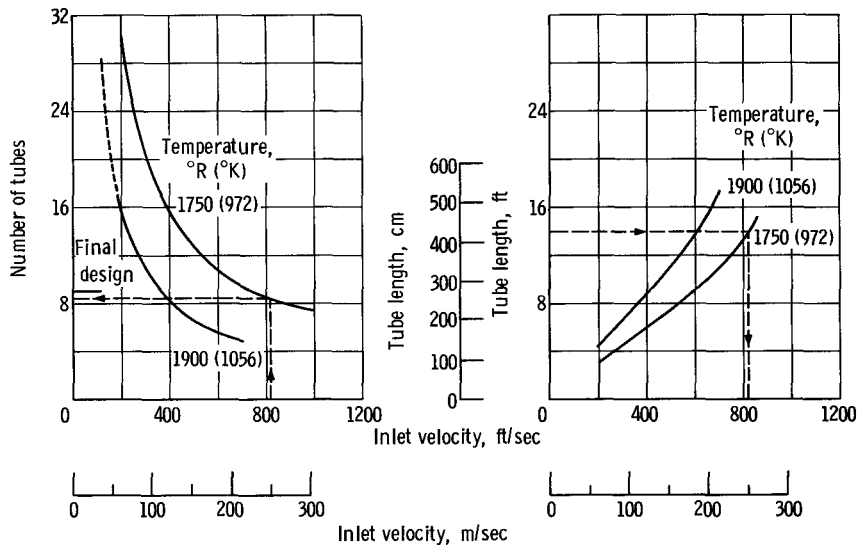
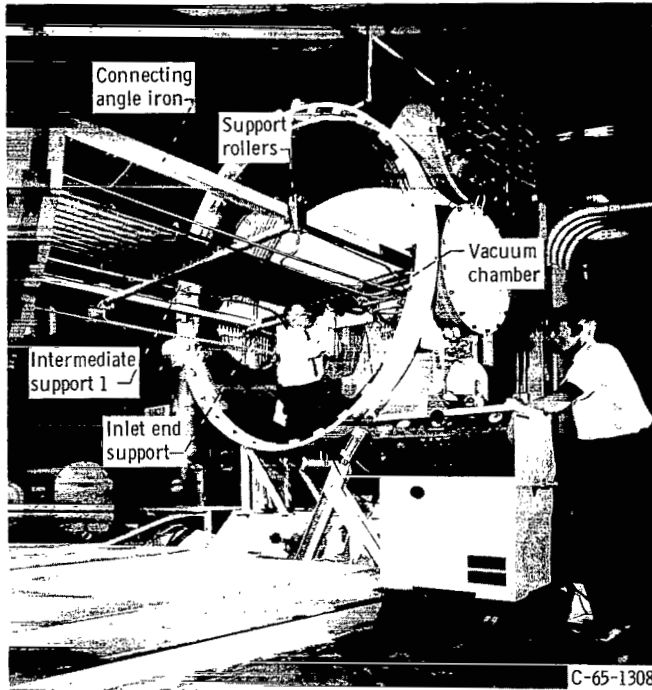
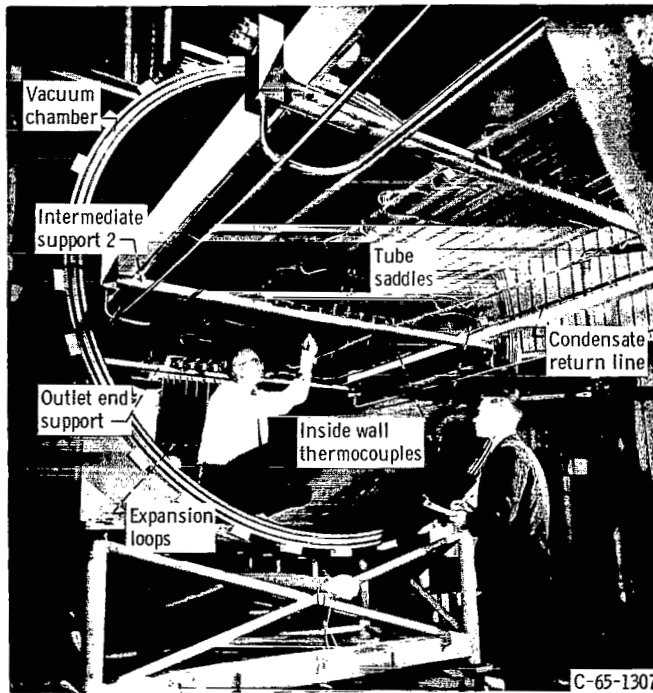

Figure 5. - Test potassium condensing radiator design. Dimensional requirements for one-tenth scale radiator from output of computer program (ref. 1). Vapor flow rate, 590 pounds per hour (267.6 kg/hr); tubes, 0.500 inch (1.27 cm) inside diameter by 0.42 inch (1.07 cm) walls; fins, 0.84 inch (2.13 cm) wide by 0.082 inch (0.208 cm) thick.



(a) View toward inlet end of radiator.



(b) View toward outlet end of radiator.

Figure 6. - Potassium condensing radiator mounted in vacuum chamber (retracted).



Figure 7. - Outlet-end oil-cooled support showing tube mounting. Relative motion during operation is indicated by scratches near bottom of tubes.

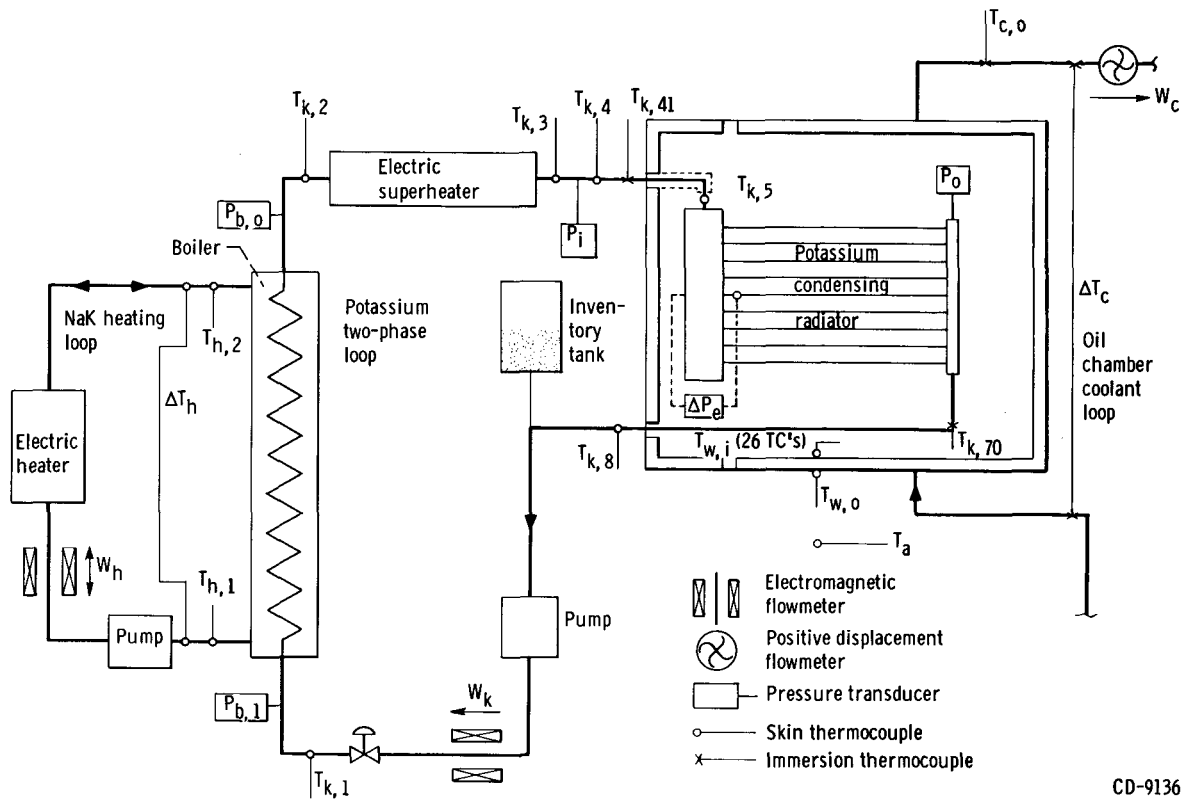

Figure 8. - Loop instrumentation.

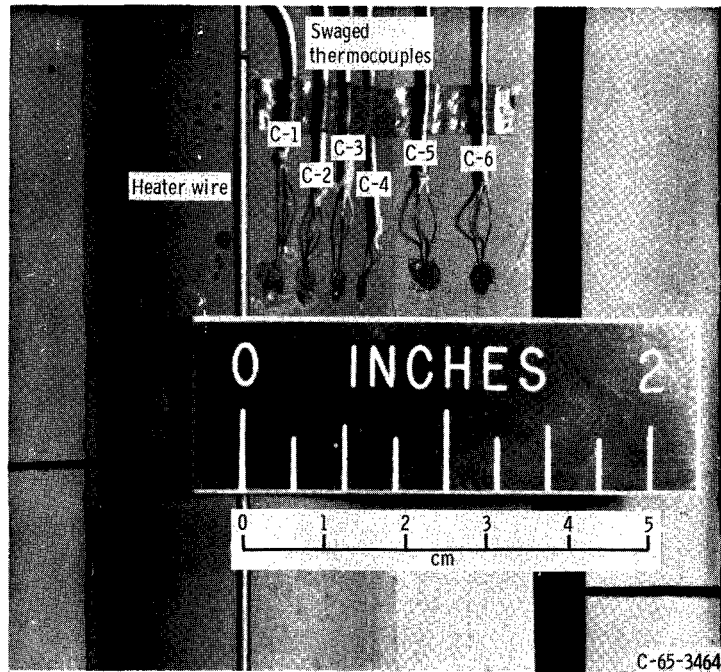
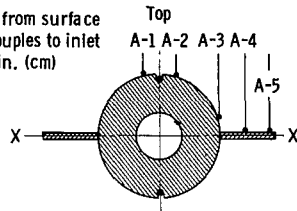
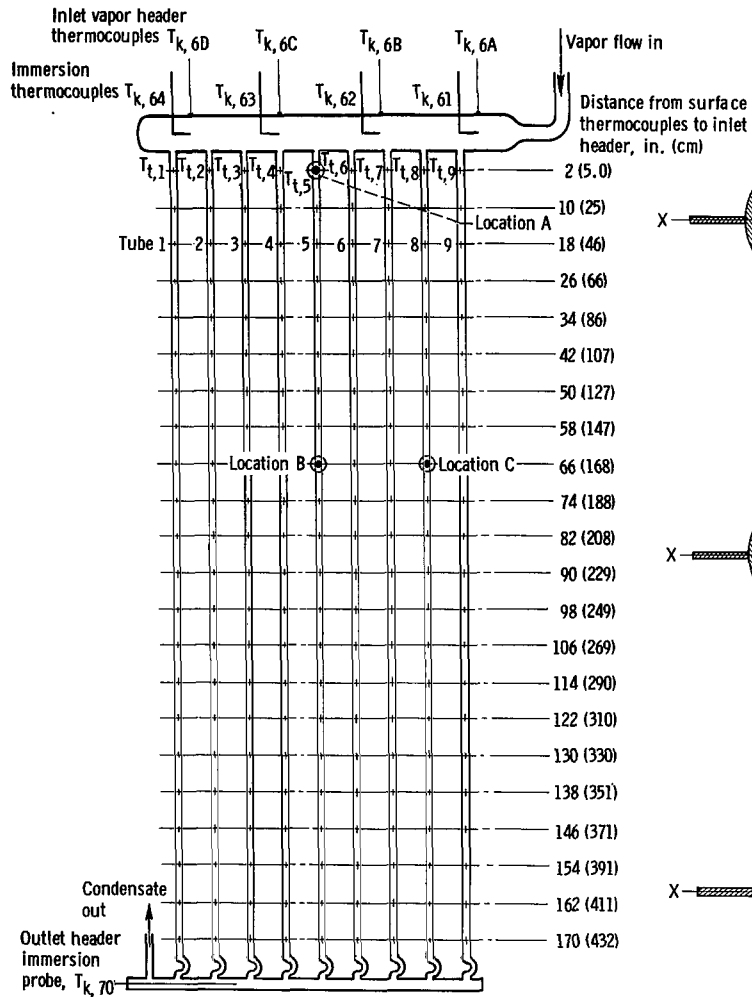
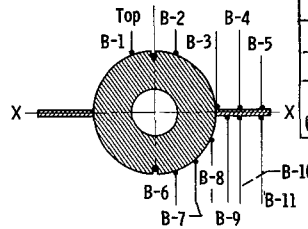

Figure 9. - Thermocouple application in potassium condensing radiator. Tube-fin cross-sectional profile thermocouples at top of tube 8, 66 inches (168 cm) from vapor header (location C in fig. 10(a)).



Thermocouple				
A-1	A-2	A-3	A-4	A-5
Projected distance from tube centerline on X-X axis, in. (cm)				
0.250 (0.635)	0.241 (0.612)	0.591 (1.501)	0.964 (2.499)	1.287 (3.269)

Location A; tube 5; 2 inches (5.0 cm) from vapor header.



Thermocouple										
B-1	B-2	B-3	B-4	B-5	B-6	B-7	B-8	B-9	B-10	B-11
Projected distance from tube centerline on X-X axis, in. (cm)										
0.224 (0.569)	0.360 (0.914)	0.689 (1.750)	1.001 (2.542)	1.322 (3.358)	0.314 (0.798)	0.538 (1.367)	0.668 (1.697)	0.854 (2.169)	1.143 (2.903)	1.317 (3.345)

Location B; tube 5; 66 inches (168 cm) from vapor header

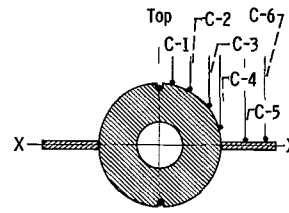

Thermocouple					
C-1	C-2	C-3	C-4	C-5	C-6
Projected distance from tube centerline on X-X axis, in. (cm)					
0.152 (0.386)	0.329 (0.836)	0.481 (1.222)	0.622 (1.580)	0.951 (2.416)	1.250 (3.175)

Location C; tube 8; 66 inches (168 cm) from vapor header

(a) Header and longitudinal profile thermocouples. Mean vapor header wall temperature $T_{m,H}$ is an average of temperatures $T_{k,6A}$, $T_{k,6B}$, $T_{k,6C}$, and $T_{k,6D}$; mean vapor inlet header immersion temperature $T_{m,g}$ is an average of temperatures $T_{k,61}$, $T_{k,62}$, $T_{k,63}$, and $T_{k,64}$.

(b) Cross-sectional profile thermocouples.

Figure 10. - Thermocouple location on potassium condensing radiator.

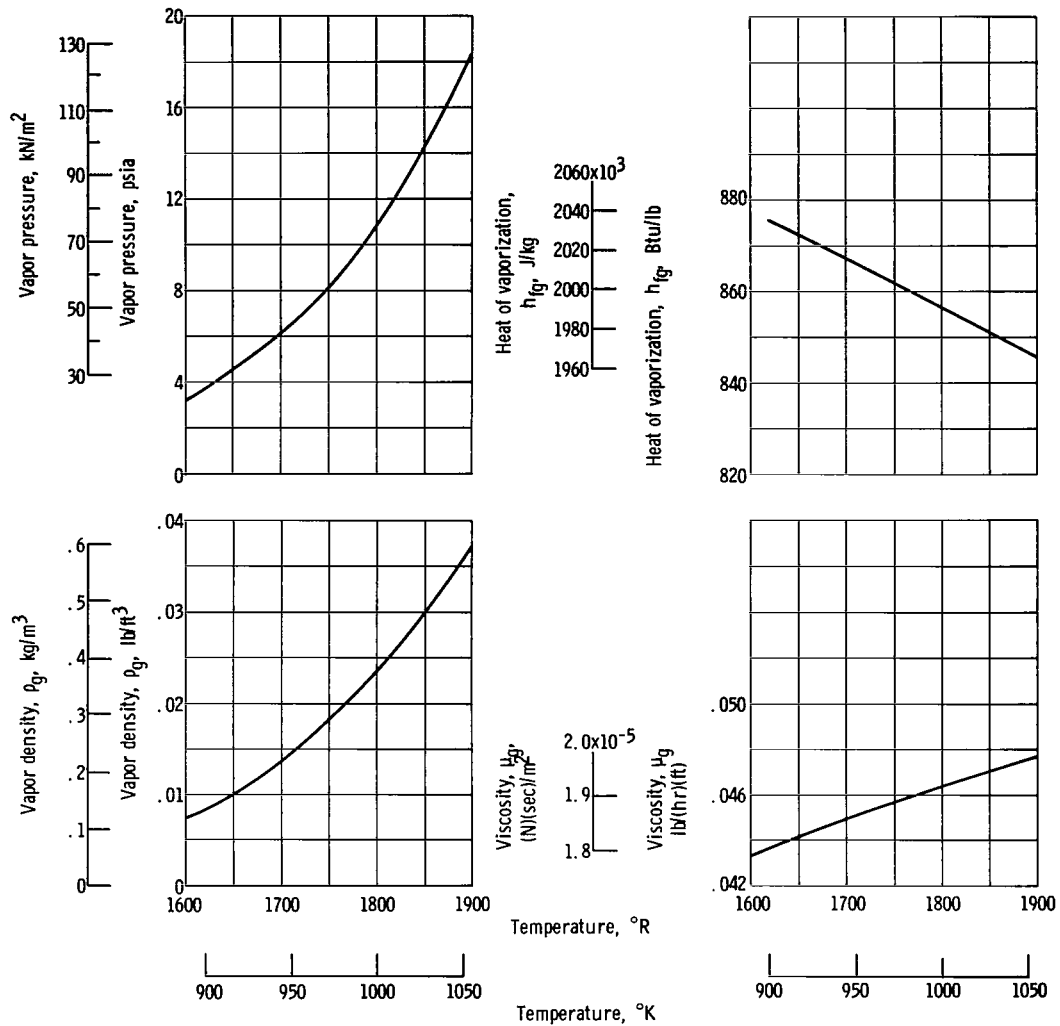

(a) Saturated vapor.

Figure 11. - Properties of potassium (ref. 10).

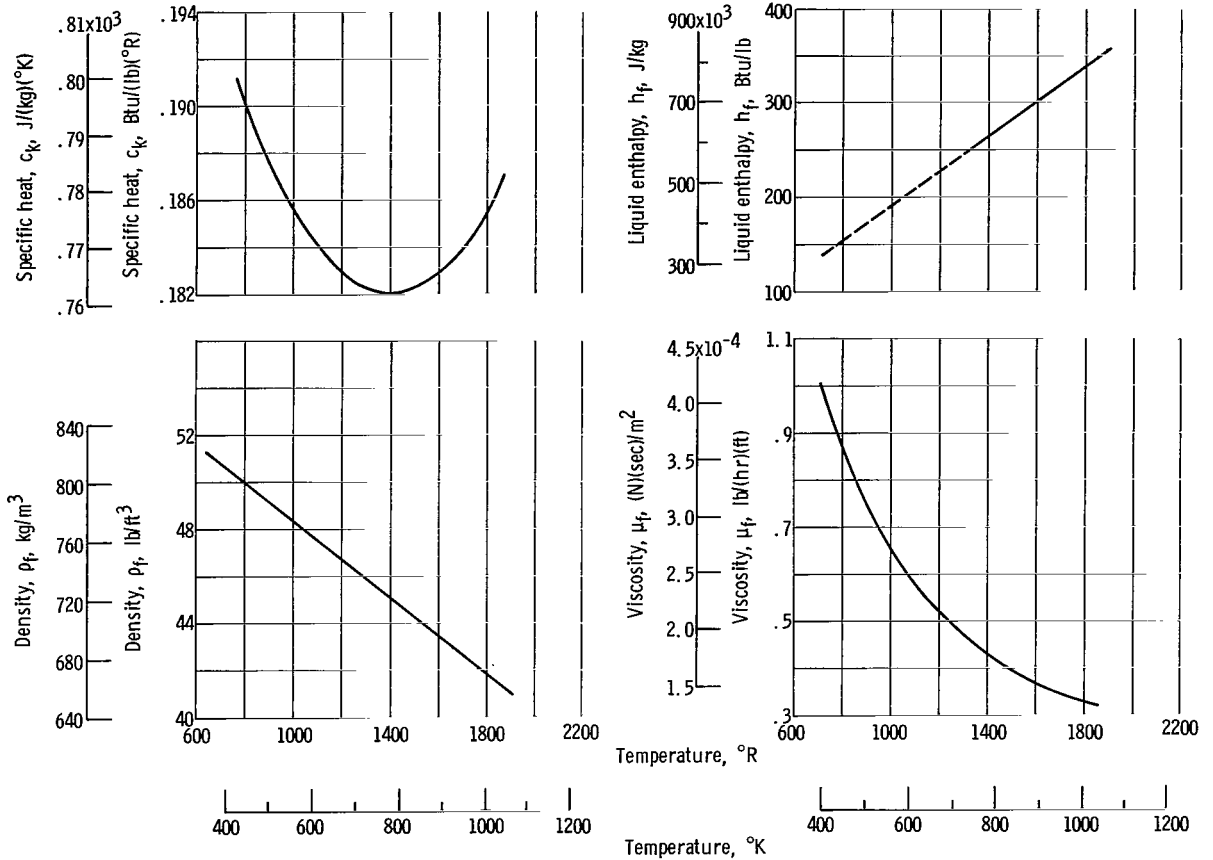

(b) Liquid.

Figure 11. - Concluded.

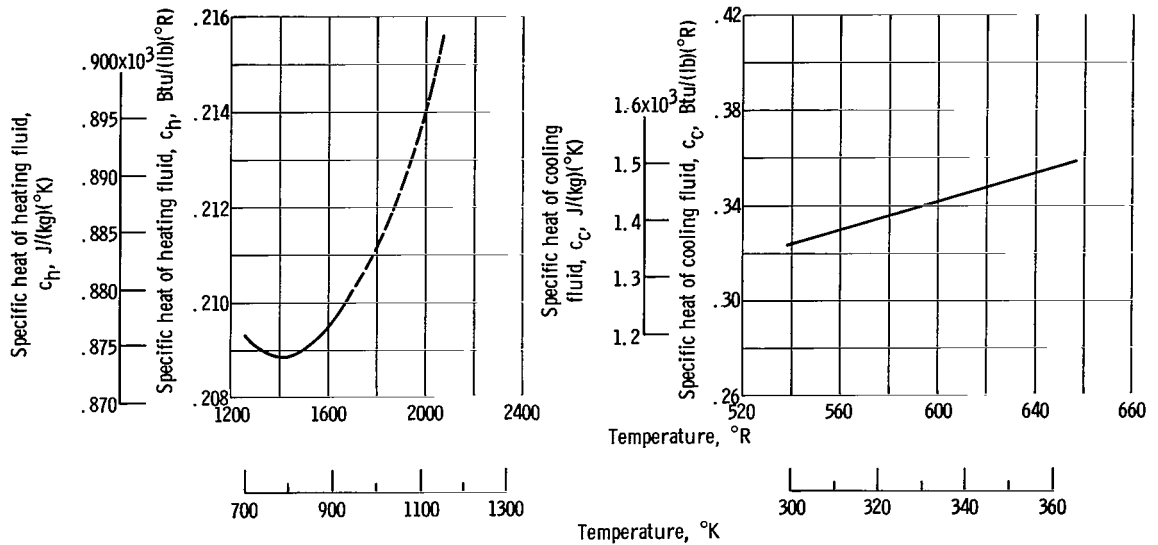

(a) NaK 78 (ref. 9).

(b) HB-40 oil.

Figure 12. - Specific heat of NaK and HB-40 oil.

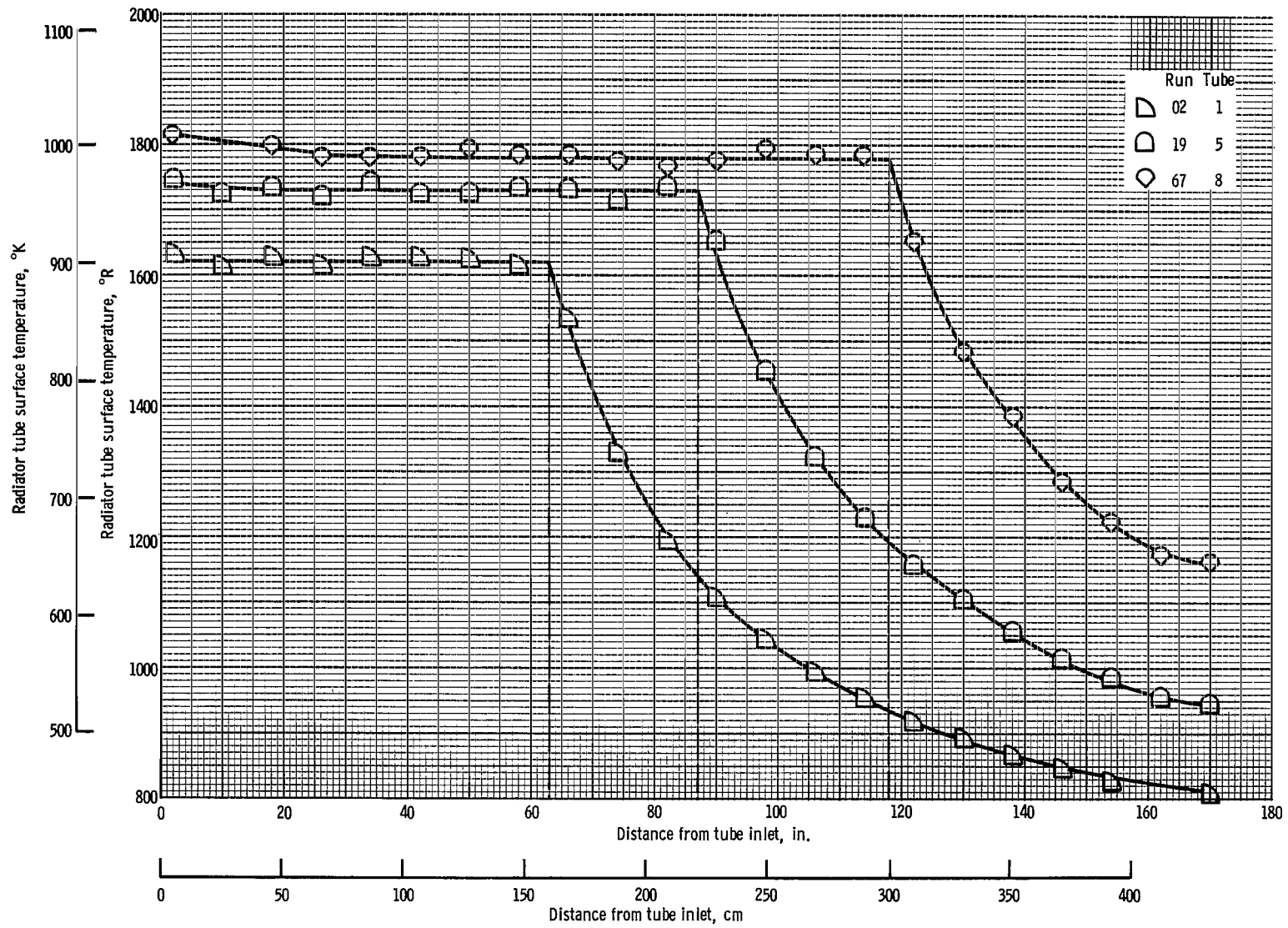

Figure 13. - Radiator tube longitudinal temperature profiles.

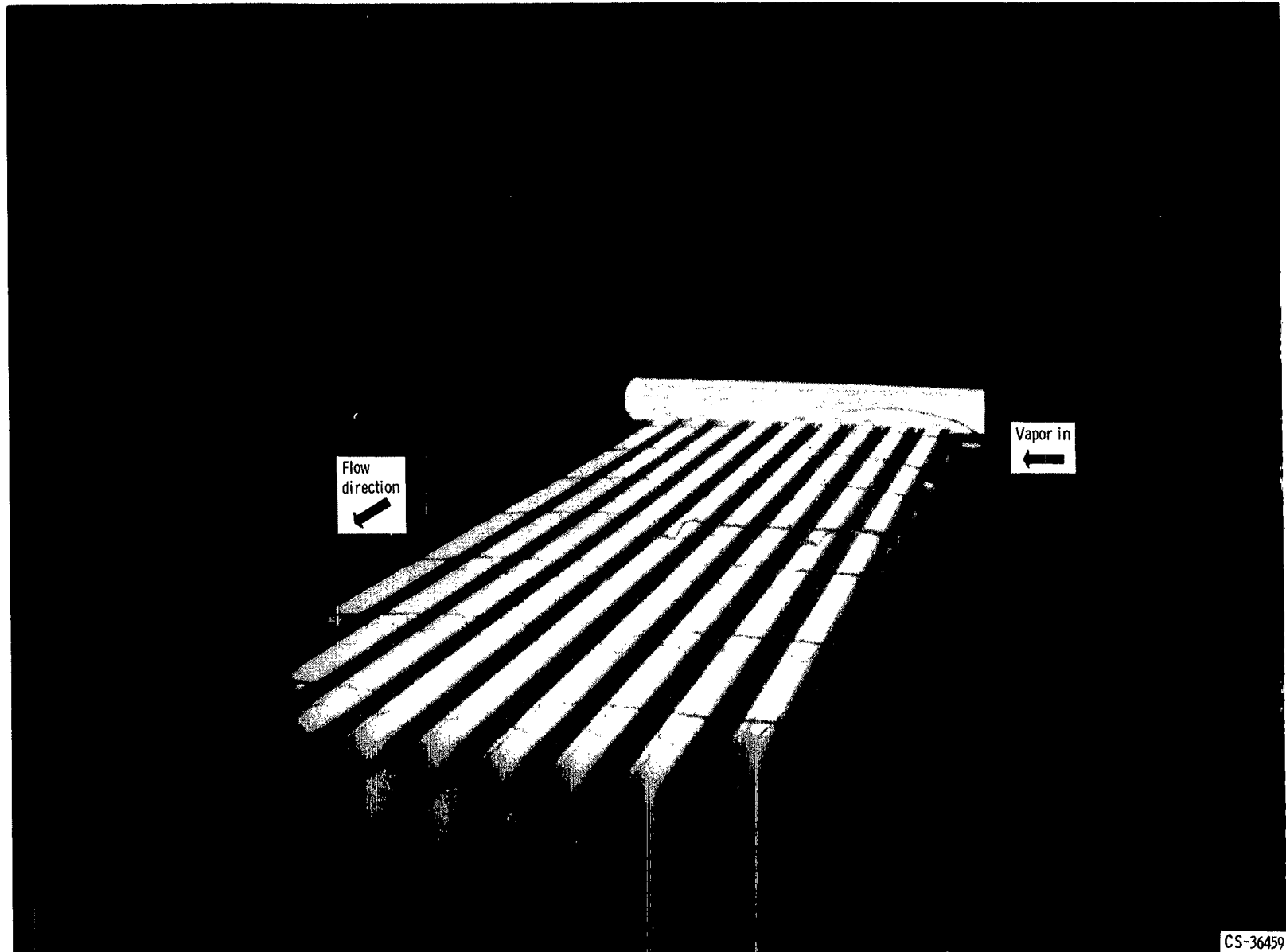

Figure 14. - Condensing radiator in operation. Photograph taken using emitted light from radiator. White area is condensing region. Gray area is start of subcooling region. Rest of subcooling region (lower end) is not sufficiently hot to be visible.



C-67-2273

Figure 15. - Condensing radiator during run 74. Flow in tube 3 is fully blocked; flow in tube 4 is partly blocked.

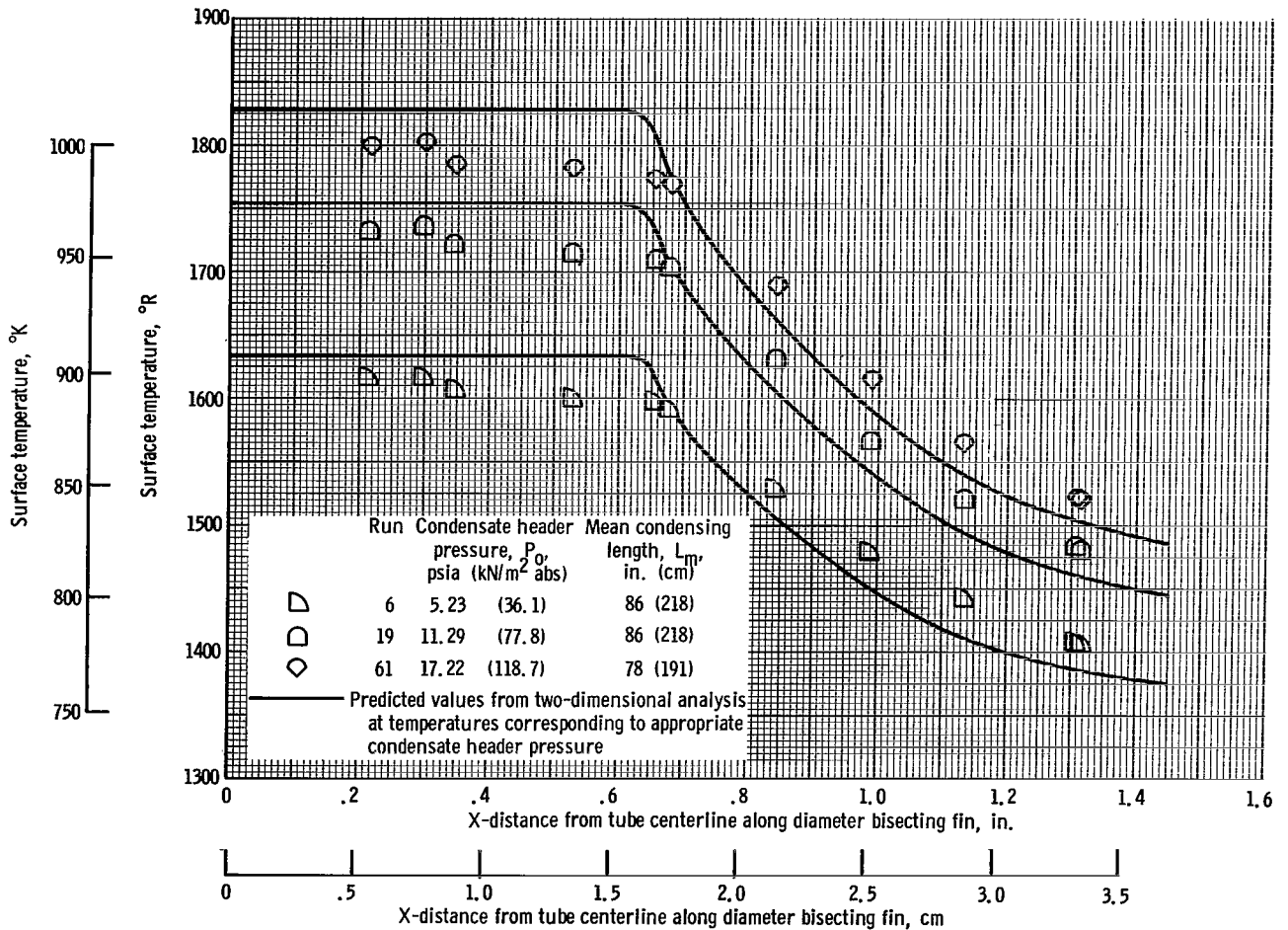
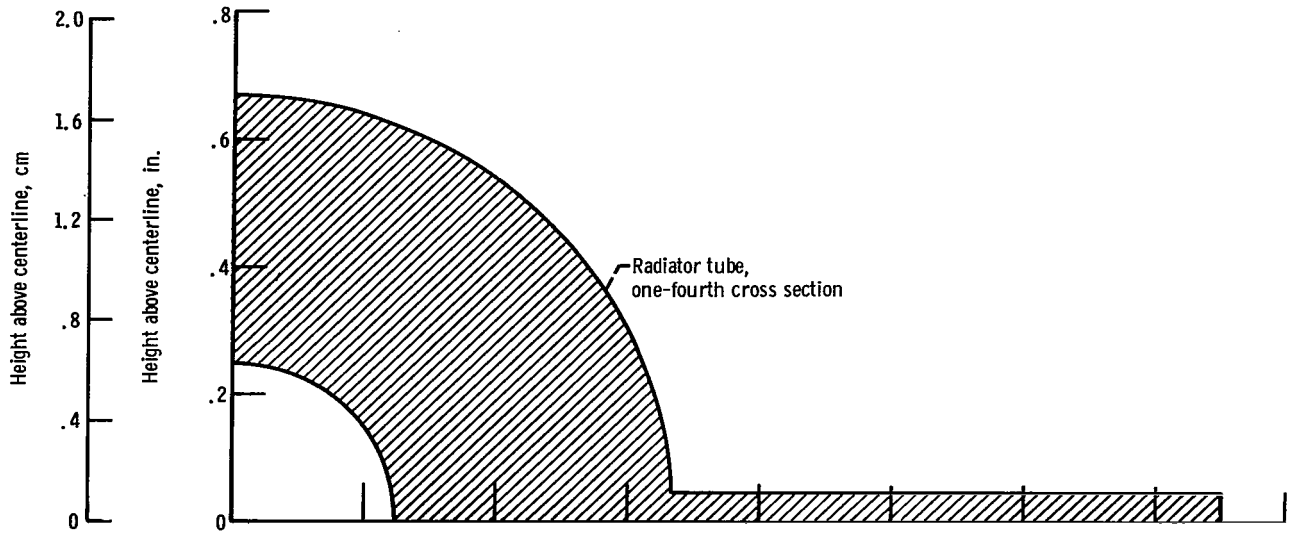

Figure 16. - Cross-sectional temperature profiles at location B. Tube $\frac{5}{8}$ distance from inlet, 66 inches (168 cm).

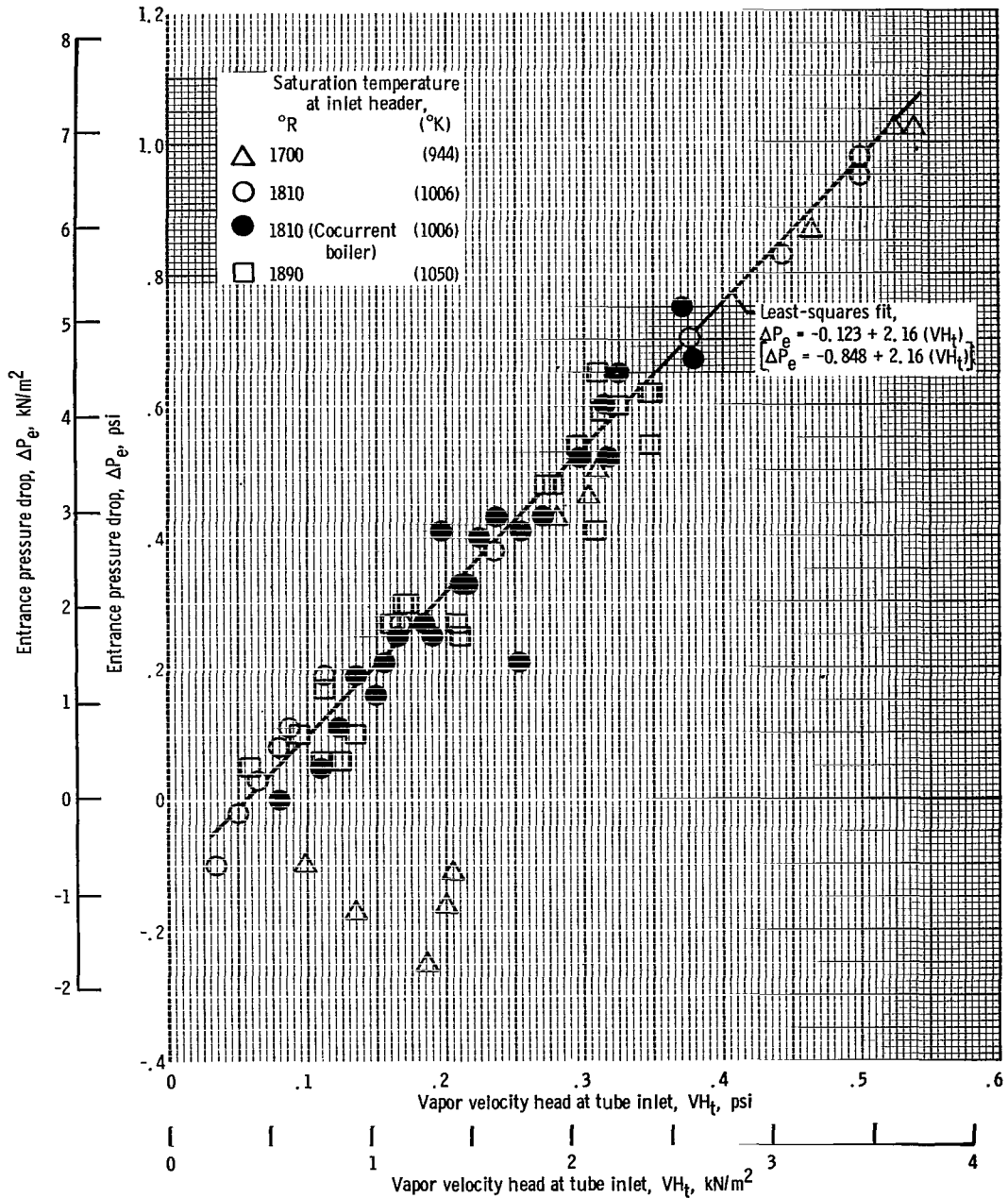

Figure 17. - Tube entrance pressure drop as function of velocity head at tube inlet for three saturation temperatures at inlet header.

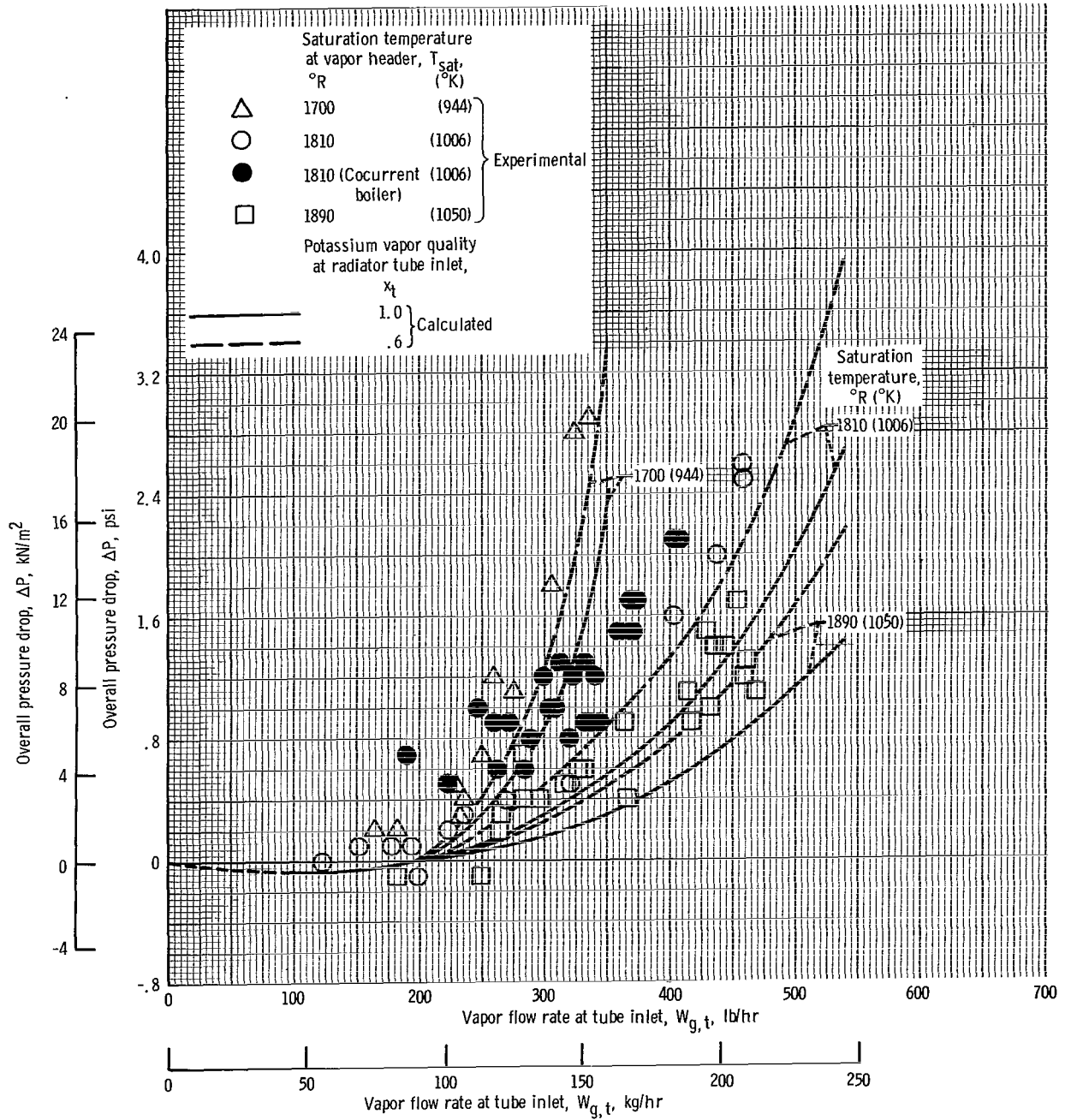

Figure 18. - Comparison of pressure-drop data with calculated values for two assumed inlet vapor qualities.

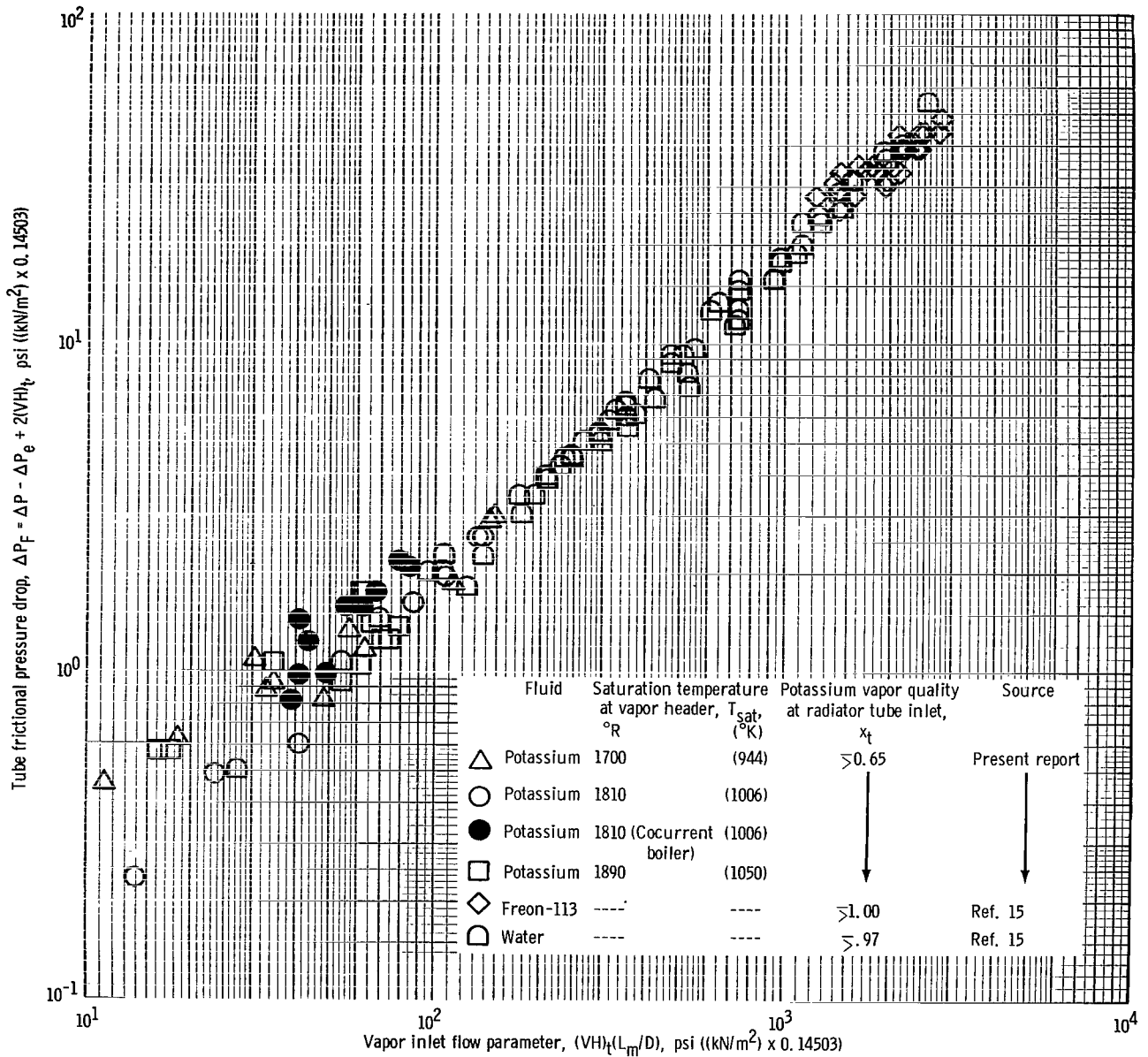

Figure 19. - Two-phase tube frictional pressure drop as function of inlet flow parameter. Comparison of potassium data for inlet qualities above 0.65 with water and Freon-113 data.

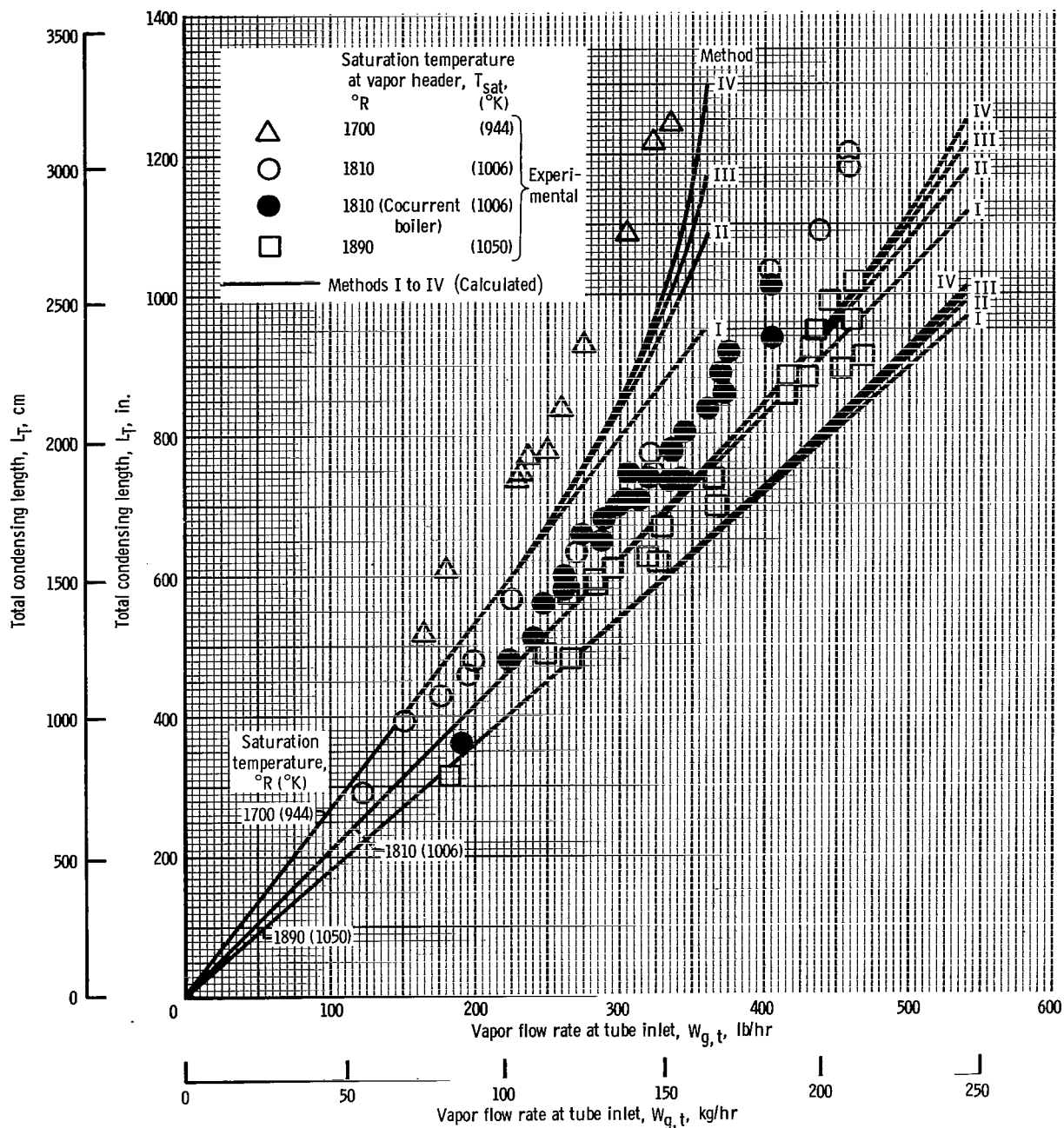

Figure 20. - Comparison of condensing-length data with predicted performance. Radiator surface total hemispherical emissivity, 0.73. Method I, all pressure drops are neglected; method II, only entrance pressure drop is considered; method III, entrance and tube pressure drop for potassium vapor quality at radiator tube inlet of 1.0 considered; method IV, entrance and tube pressure drop for potassium vapor quality at radiator tube inlet of 0.6 considered.

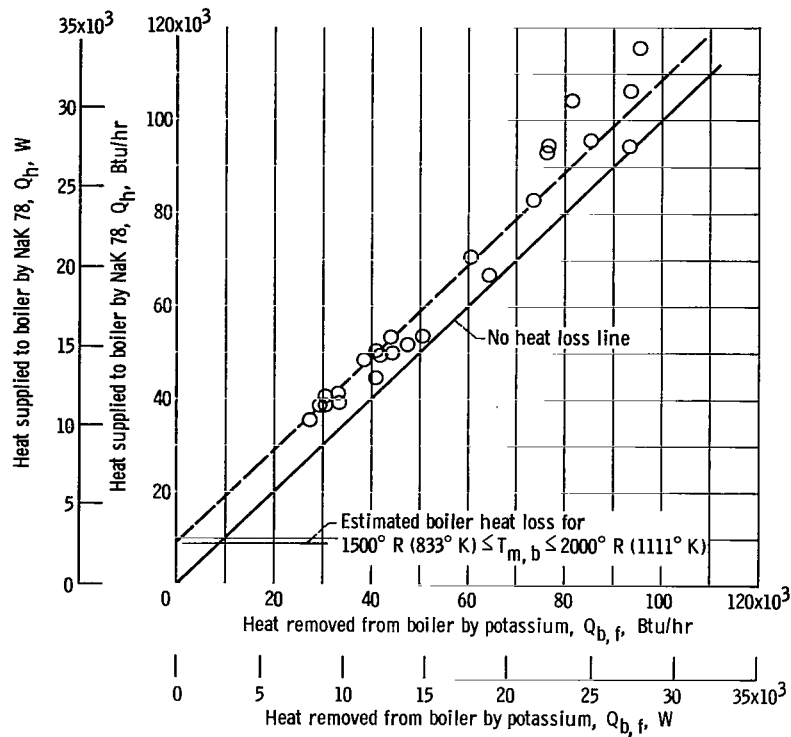

Figure 21. - Heat-loss calibration from liquid-liquid data. Boiler shell losses.

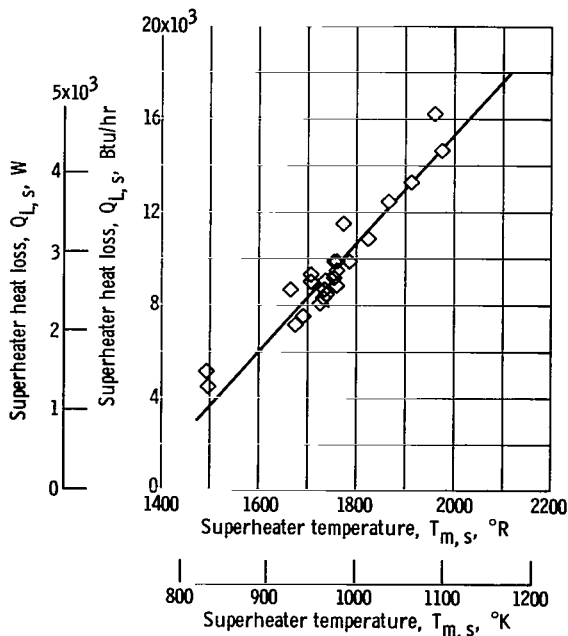

Figure 22. - Heat loss calibration from all-liquid data. Superheater losses.

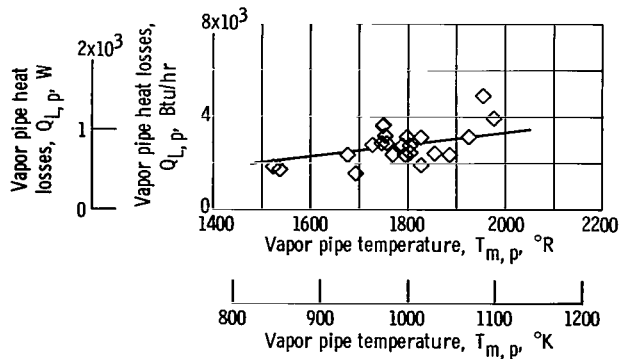

Figure 23. - Heat loss calibration from liquid-liquid data. Vapor pipe losses.

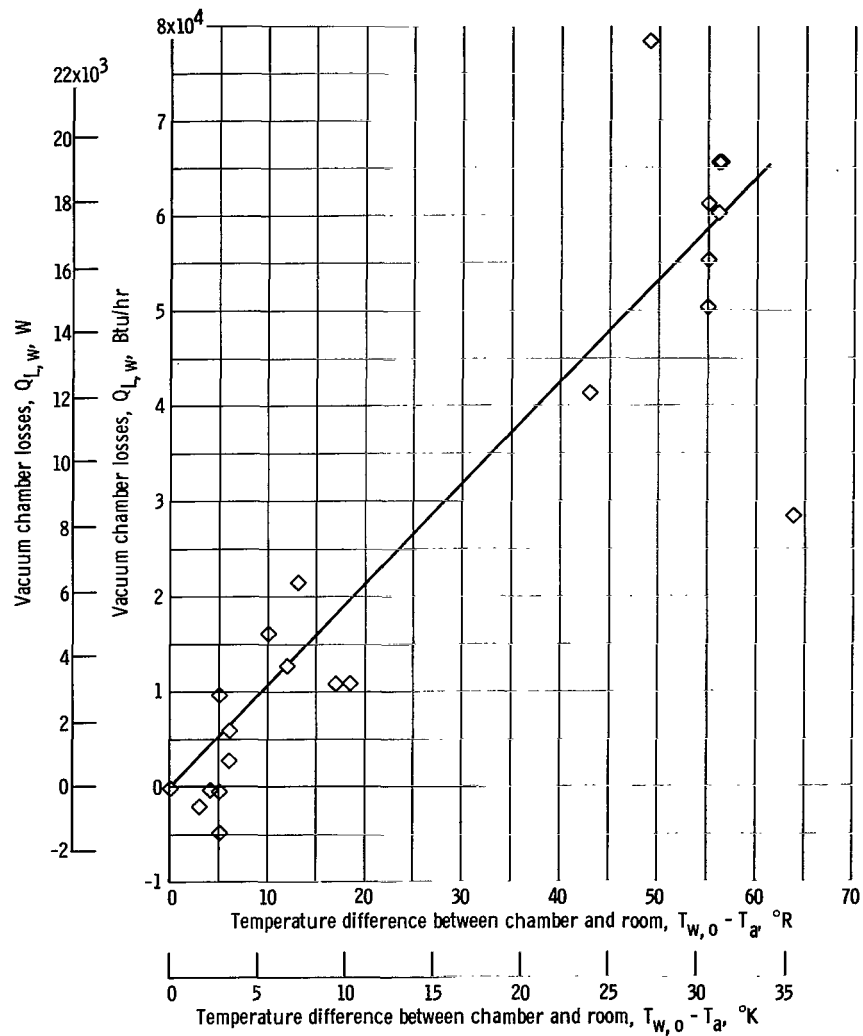

Figure 24. - Heat-loss calibration from liquid-liquid data. Vacuum chamber losses.

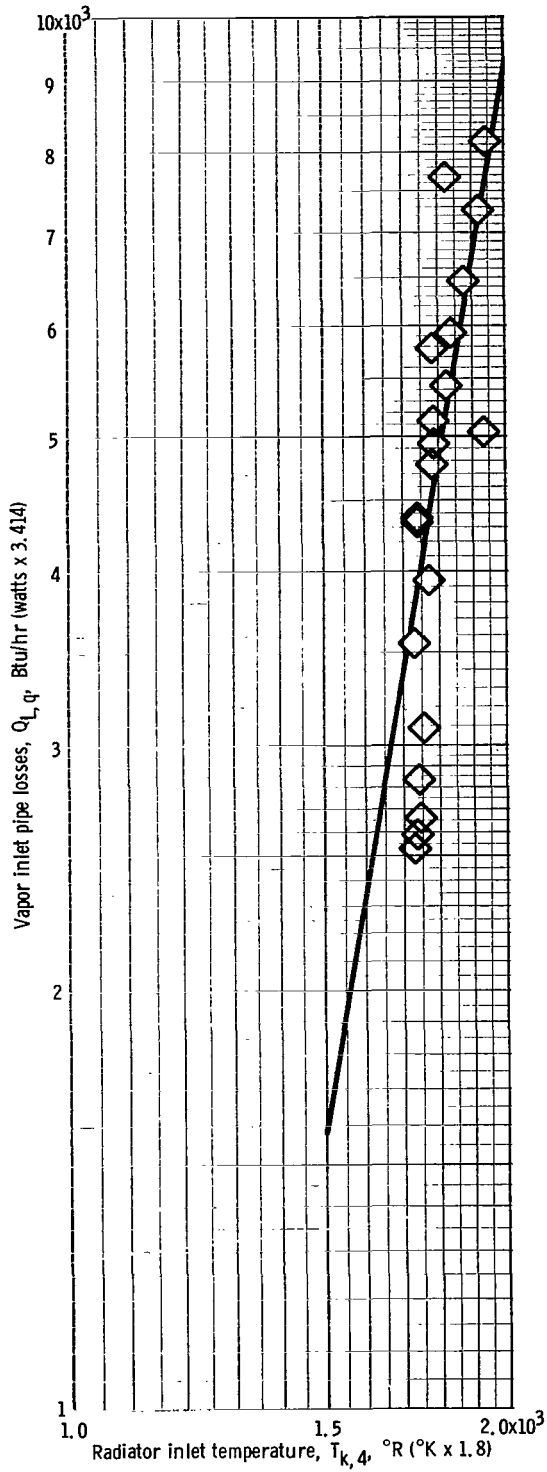

Figure 25. - Heat loss calibration from liquid-liquid runs. Vapor inlet pipe inside vacuum chamber.

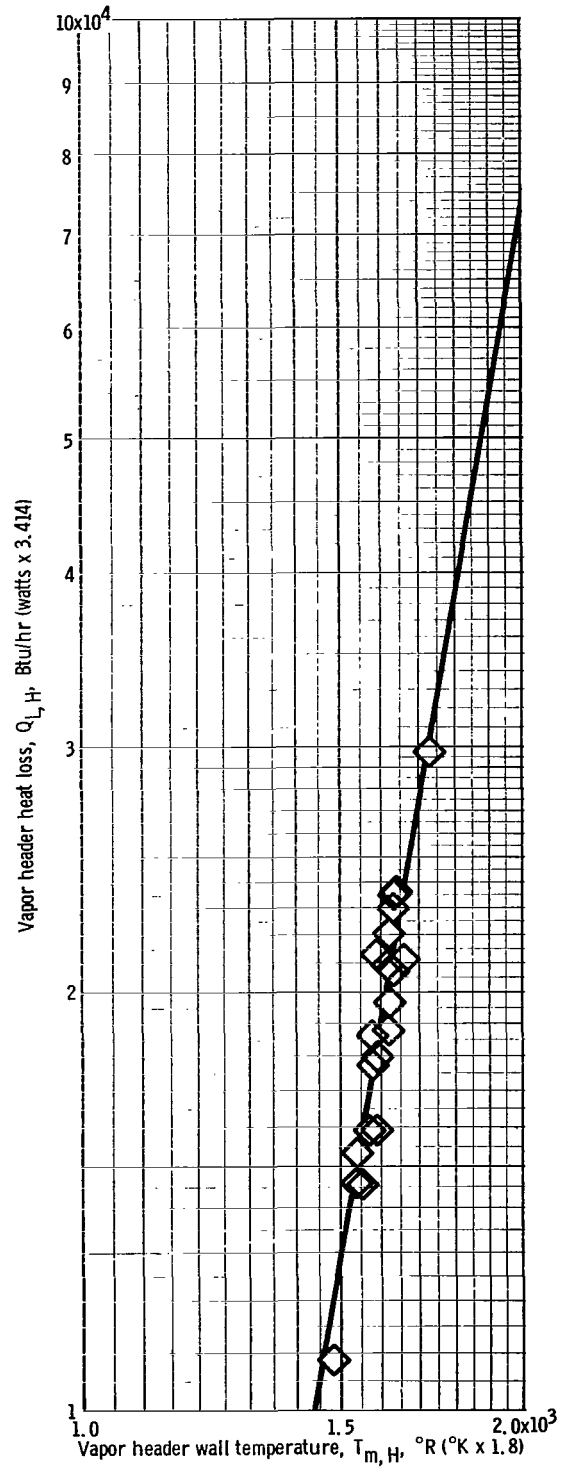

Figure 26. - Heat loss calibration from liquid-liquid runs. Vapor header losses.

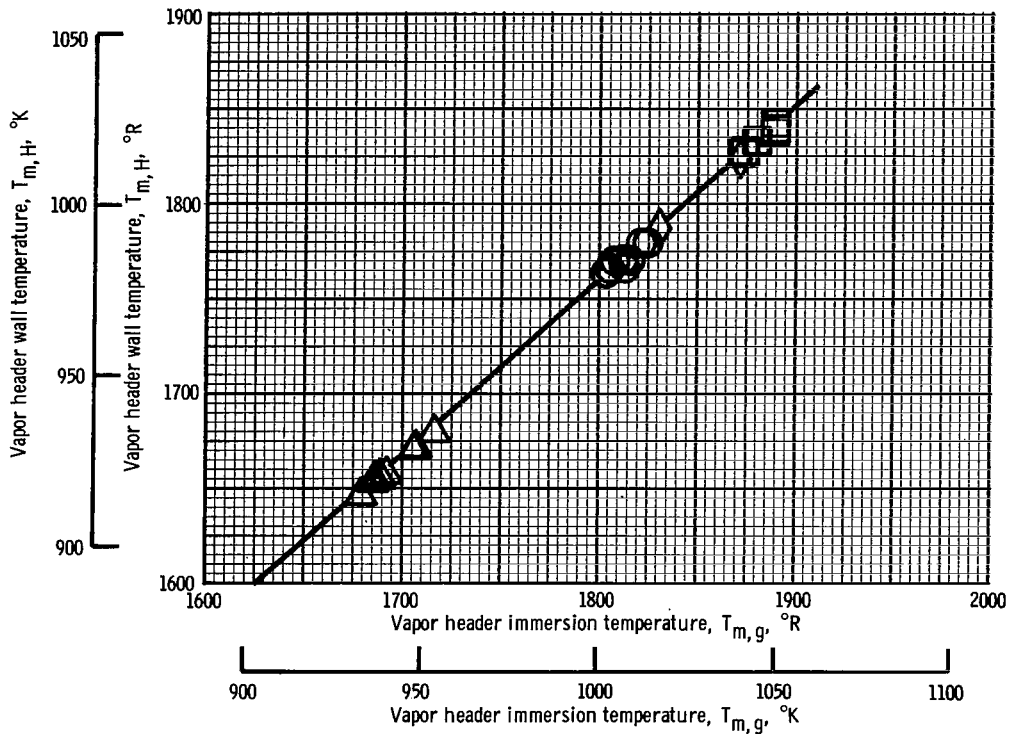

Figure 27. - Vapor header wall temperature as function of immersion temperature for condensing data points.

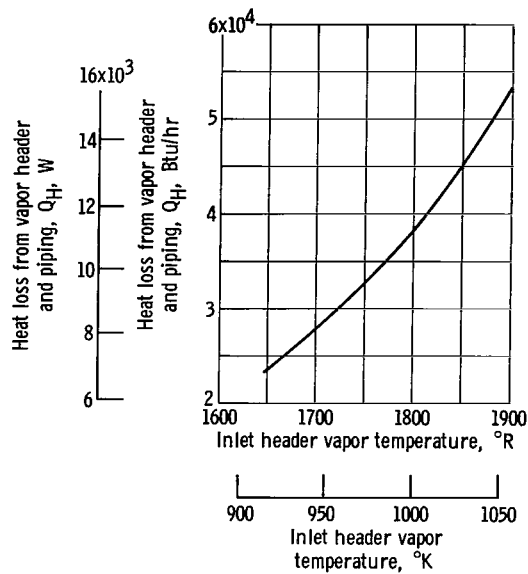

Figure 28. - Heat loss from vapor header and inlet pipe as function of vapor temperature. (Combined data from figs. 24 to 26.)

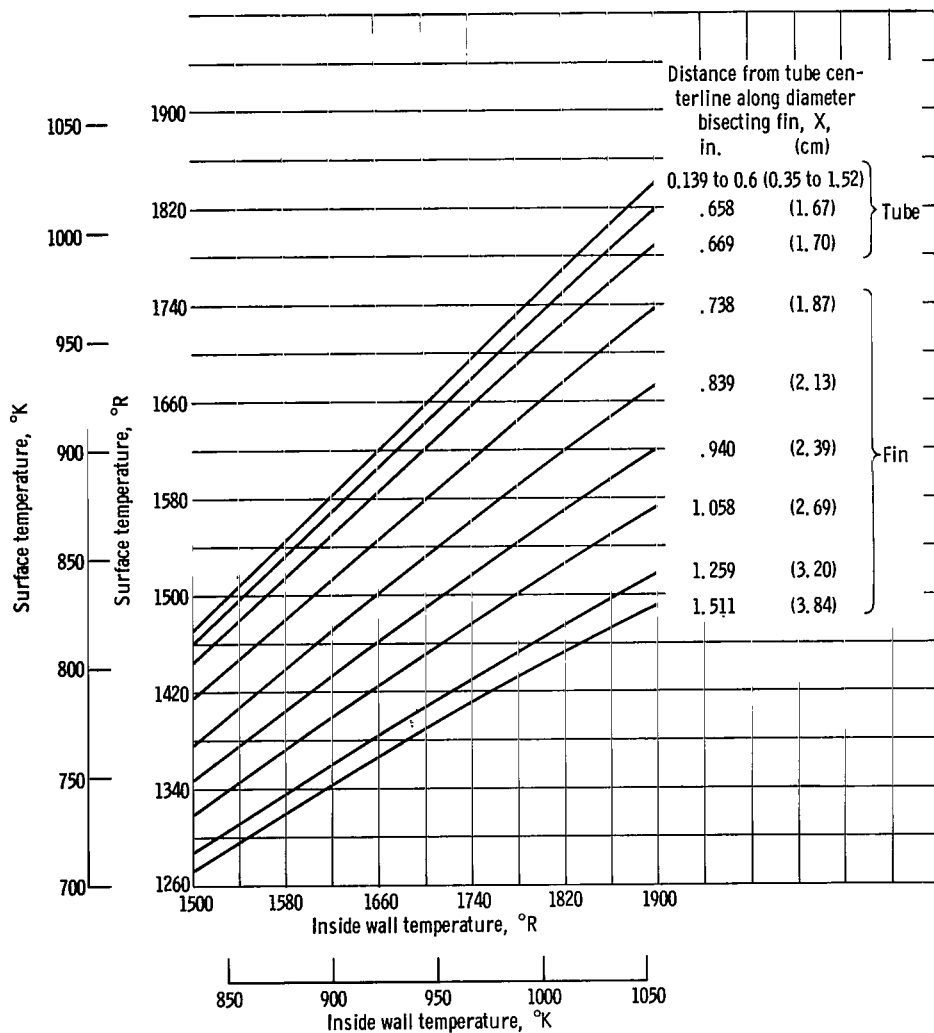

Figure 29. - Surface temperature distribution as predicted by two-dimensional analysis (ref. 2). Vacuum chamber inside wall temperature, 650° R (361° K); radiator surface total hemispherical emissivity, 0.73.

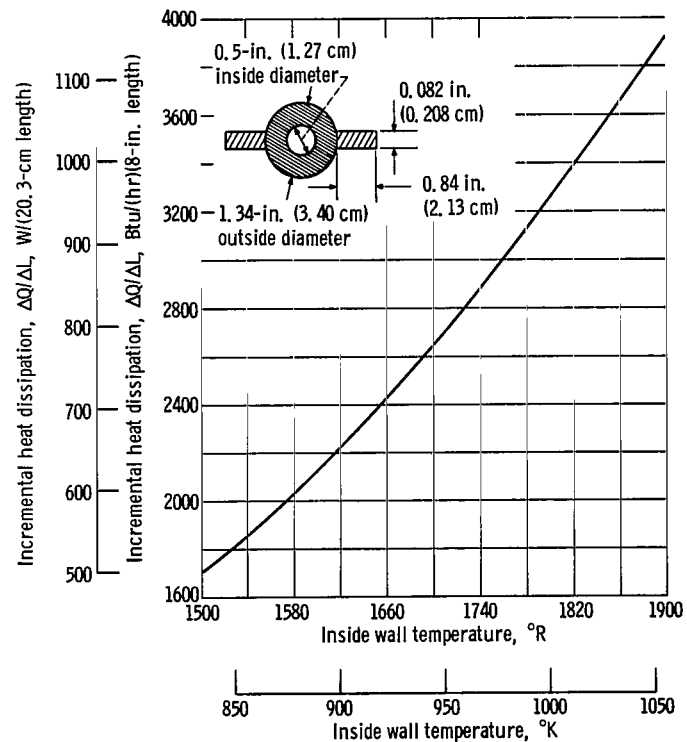

Figure 30. - Heat dissipation from condenser surface as predicted by two-dimensional analysis based on radiator surface total hemispherical emissivity of 0.73, uniform inside wall temperature, constant wall thermal conductivity at inside temperature value, cross-sectional input data (see inset), AISI 316 stainless steel, and sink temperature of 650° R (361° K).

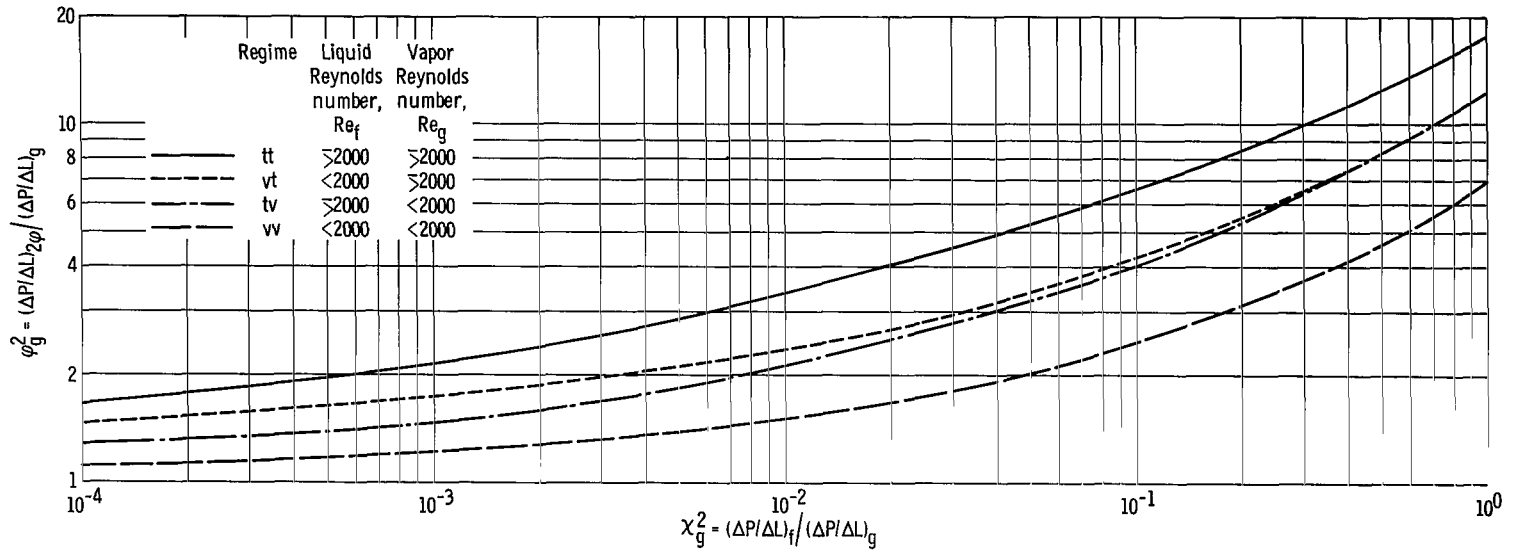
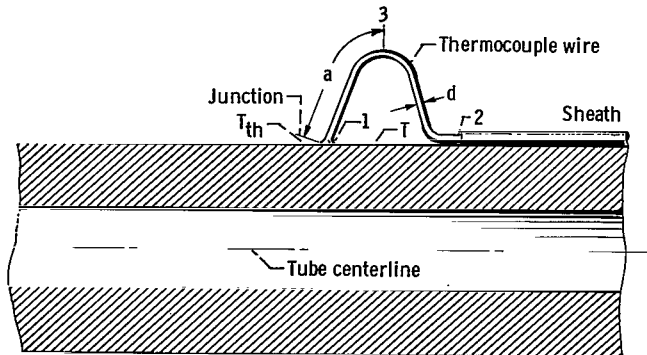

Figure 31. - Relation between χ_g^2 and ϕ_g^2 from Lockhart-Martinelli (ref. 12).



CD-9135

Figure 32. - Schematic diagram of thermocouple application to radiator tube surface. Thermocouple radiating length, a ; thermocouple diameter, d ; true surface temperature, T ; thermocouple actual reading, T_{th} ; thermocouple junction, point 1; end of exposed bare wire, point 2; midpoint of exposed bare wire, point 3.

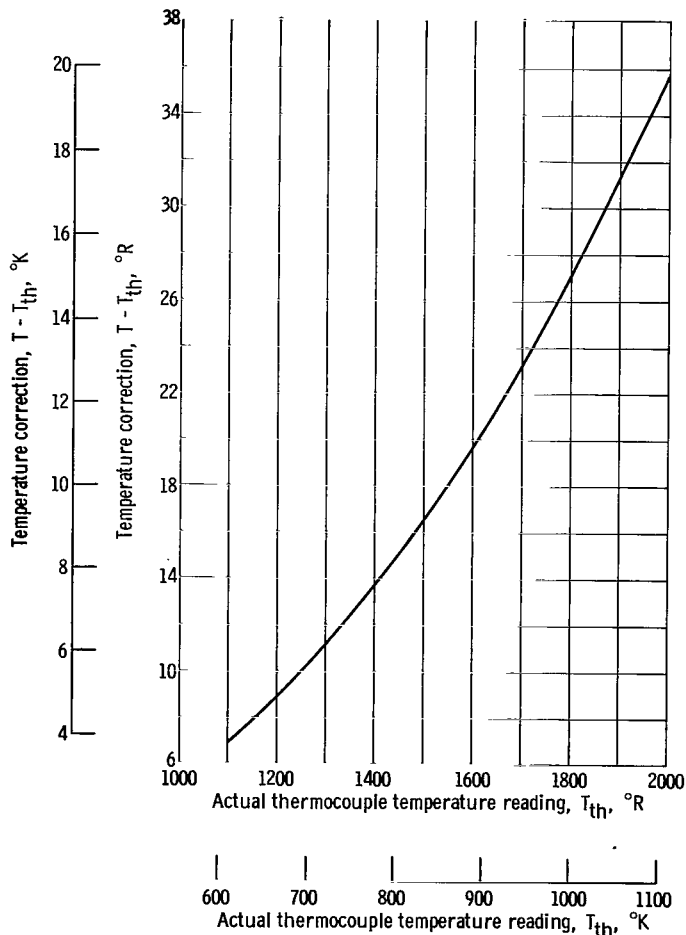

Figure 33. - Maximum systemic error of radiator tube surface thermocouple. ($T = T_{th} + \text{correction}$)

"The aeronautical and space activities of the United States shall be conducted so as to contribute . . . to the expansion of human knowledge of phenomena in the atmosphere and space. The Administration shall provide for the widest practicable and appropriate dissemination of information concerning its activities and the results thereof."

—NATIONAL AERONAUTICS AND SPACE ACT OF 1958

NASA SCIENTIFIC AND TECHNICAL PUBLICATIONS

TECHNICAL REPORTS: Scientific and technical information considered important, complete, and a lasting contribution to existing knowledge.

TECHNICAL NOTES: Information less broad in scope but nevertheless of importance as a contribution to existing knowledge.

TECHNICAL MEMORANDUMS: Information receiving limited distribution because of preliminary data, security classification, or other reasons.

CONTRACTOR REPORTS: Scientific and technical information generated under a NASA contract or grant and considered an important contribution to existing knowledge.

TECHNICAL TRANSLATIONS: Information published in a foreign language considered to merit NASA distribution in English.

SPECIAL PUBLICATIONS: Information derived from or of value to NASA activities. Publications include conference proceedings, monographs, data compilations, handbooks, sourcebooks, and special bibliographies.

TECHNOLOGY UTILIZATION PUBLICATIONS: Information on technology used by NASA that may be of particular interest in commercial and other non-aerospace applications. Publications include Tech Briefs, Technology Utilization Reports and Notes, and Technology Surveys.

Details on the availability of these publications may be obtained from:

SCIENTIFIC AND TECHNICAL INFORMATION DIVISION
NATIONAL AERONAUTICS AND SPACE ADMINISTRATION

Washington, D.C. 20546