

NASA TECHNICAL NOTE



NASA TN D-4234

c. 1

NASA TN D-4234

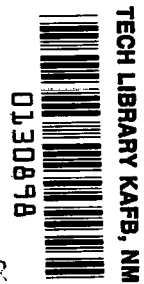

**LOAN COPY: RETURN
AFWL (W111-2)
KIRTLAND AFB, N MEX**

A USEFUL MODIFICATION OF THE WRIGHT SPIROMETER

by James Roman and Robert N. Sato

Flight Research Center

Edwards, Calif.





A USEFUL MODIFICATION OF THE WRIGHT SPIROMETER

By James Roman
Flight Research Center
Edwards, Calif.

and

Robert N. Sato
Project Consultant

NATIONAL AERONAUTICS AND SPACE ADMINISTRATION

For sale by the Clearinghouse for Federal Scientific and Technical Information
Springfield, Virginia 22151 - CFSTI price \$3.00

A USEFUL MODIFICATION OF THE WRIGHT SPIROMETER

By James Roman
NASA Flight Research Center

and

Robert N. Sato*
Project Consultant

SUMMARY

The Wright spirometer is a useful gas flowmeter for physiological use, in that it is small and reliable. However, data collected with this device must be reduced manually, and the calibration curve is nonlinear at low flow values. The instrument was modified by fitting the output shaft with a spoked wheel that interrupts the light beam between a low-power light source and a photosensor. This modification provides a digital electrical output that can be computer-reduced, permitting correction of the data for the nonlinearity of the calibration curve. The power drain is 96 milliwatts, which is small enough to be drawn from the battery supplies of most self-contained miniature tape recorders.

INTRODUCTION

The measurement of respiratory minute volume is of considerable interest to both the clinician and the physiologist. This measurement has been extended only rarely into the dynamic environment, usually by means of large, cumbersome spirometers. Smaller devices are available with which to measure mass flow; however, the conversion from mass flow to minute volume requires that pressure and temperature be available, which significantly complicates the measurement of respiratory volume.

The well-known Wright spirometer (fig. 1) is an excellent device for measuring mass flow, in that it is small and reliable; however, for measuring respiratory volumes and rates in the flight environment it is not entirely adequate in two respects. First, it does not feature an electronically recordable output, which requires that the instrument be read every minute and the reading recorded manually. Second, the calibration of the device is nonlinear; that is, the relationship between volume through the instrument and the reading of the instrument does not remain constant over an adequately large range.

*Ph. D. candidate, Department of Electrical Engineering, University of Southern Calif., employed as instrumentation consultant by the Flight Research Center for this project.

Because of the small size of the Wright spirometer, the advanced stage to which its development was carried, and its proved reliability, it was decided to circumvent both these deficiencies by modifying the device to provide a digital electrical output. Through this modification, the device provided one square wave pulse for every unit of volume that flowed through it. Since all the biomedical information of the flight research program (ref. 1) under which this device was developed is computer-reduced, it was simple to make the calibration factor of the device dependent upon instantaneous flow.

This paper discusses the modifications made to the Wright spirometer and the performance of the modified instrument.

DESCRIPTION OF THE BASIC INSTRUMENT

The Wright spirometer* (fig. 1) is designed to measure gas volume. This is presented on the dials on the face of the device. The unmodified instrument operates as follows: The gas entering the unit is distributed through near-tangential slots in a

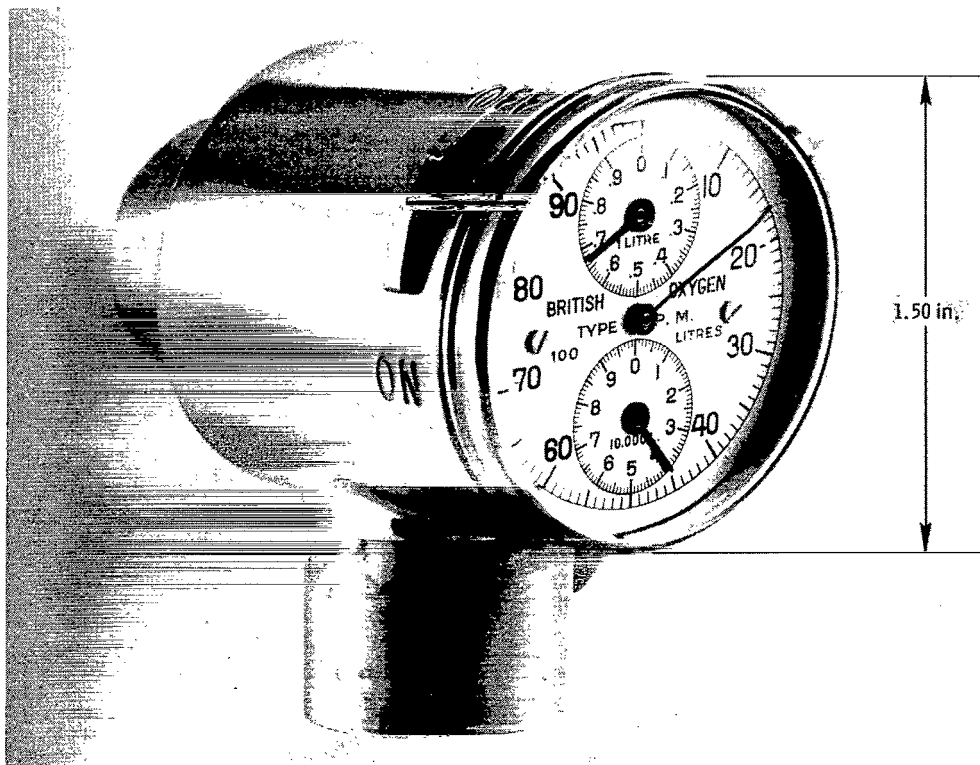

E-16851

Figure 1.— The Wright spirometer as available commercially.

*Invented by Dr. B. M. Wright of the National Institute for Medical Research (England).

cylindrical stator and impinges upon a flat, blade-like rotor before leaving the stator axially through the outlet. The flat rotor, mounted on a shaft, rotates as a result of the gas flow through the slots (fig. 2). The axis of these slots is not radial but is directed at an angle to a radius through the slot centerline. The angular velocity of the rotor blade is approximately proportional to the flow through the instrument. The rotor shaft is coupled to the watch-like hands on the dial of the device through a gear train. The housing containing the gear train and bearings is mercury-sealed against moisture. The bearings are jeweled. Flow through the device is one way. The mechanism is designed to minimize the angular moment of inertia of the rotor and gear train. The spirometer registers total volume passed through it, until reset. It can be used to determine mean flow rates when employed in conjunction with a stopwatch.

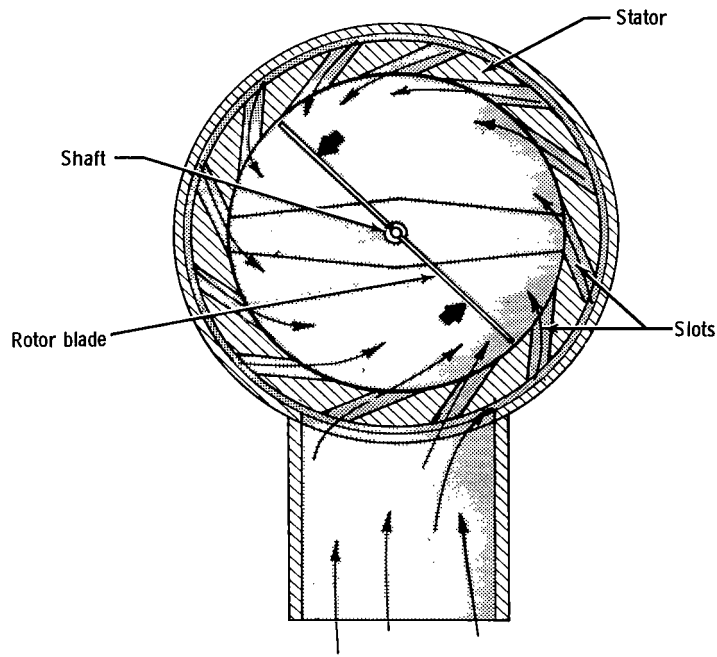

Figure 2.— Cross-section of the Wright spirometer showing how the inlet gases acquire an angular velocity proportional to flow rate.

MODIFICATION OF THE INSTRUMENT

The modifications made to the spirometer to enable it to provide a digital electrical output consisted of removing the dial and hands and substituting for them a spoked wheel that interrupts the light from a miniature lamp to a semiconductor photonsensor, and installing a signal-conditioning amplifier.

On the unmodified instrument a complete revolution of the upper hand (fig. 1) is produced when 1 liter of gas has passed through the spirometer. A spoked wheel (10 spokes) was substituted for the 1-liter hand, and all gears except those necessary to drive the 1-liter shaft were removed along with the 100- and 10,000-liter shafts.

The miniature lamp was placed within the circumference of the spoked wheel to serve as a light source for a pair of photosensitive semiconductor devices (figs. 3 and 4).

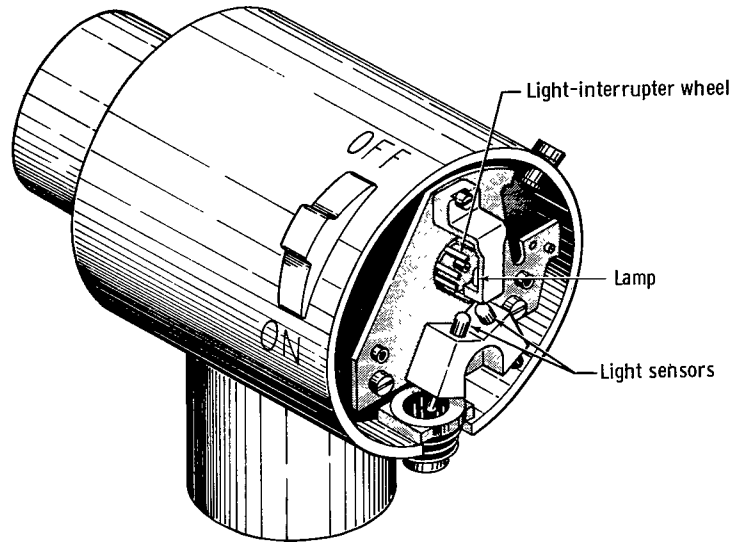

(a) Assembly drawing.

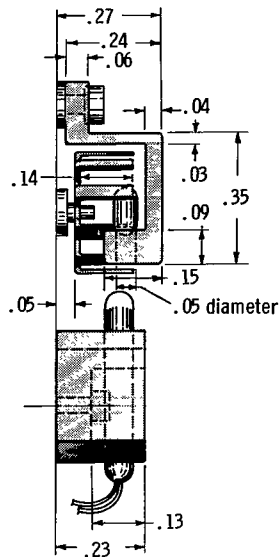

(b) Side view of photosensor, miniature light, and spoked-wheel assembly.

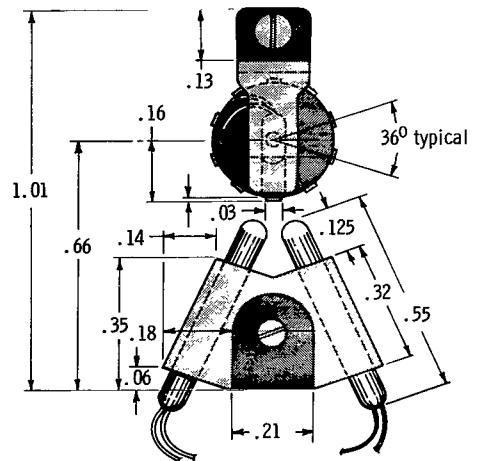

(c) Top view of photosensors and spoked-wheel assembly.

Figure 3.— The modified Wright spirometer. Dimensions in inches unless otherwise noted.

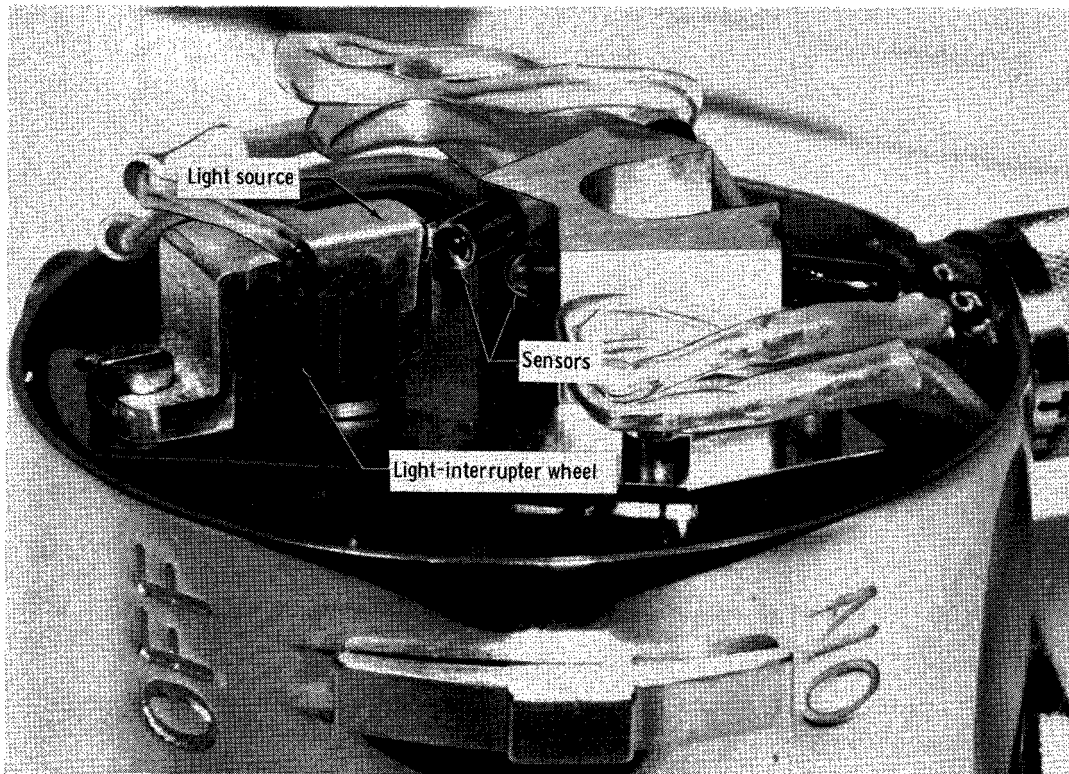

Figure 4.— The modified Wright spirometer.

E-15726

The passage of each spoke across the light source results in a clean square pulse at the output of the signal-conditioning amplifier. A simplified block diagram of the signal-conditioning circuitry is shown in figure 5.

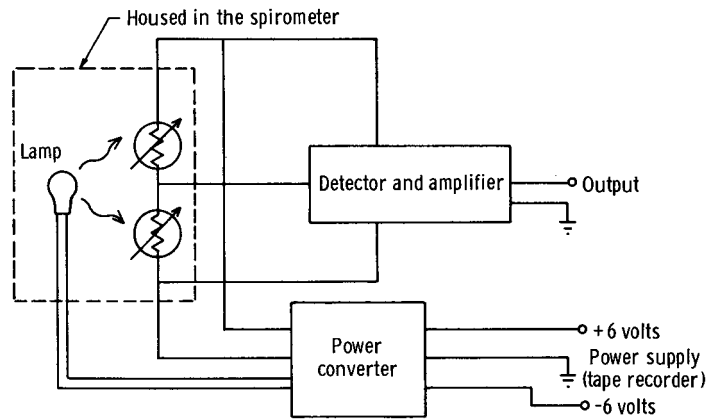

Figure 5.— Simplified block diagram of signal-conditioning circuitry.

Volume is computer-reduced by counting the number of pulses, and flow is computed by noting the number of pulses per unit time. Each pulse is equivalent to 0.1 liter. This resolution is adequate for most respiration work in which mean values for 1 minute are used. For breath-by-breath respiration work, this resolution would not be adequate, and a different wheel would have to be used.

A second photonsensor was used to cancel modulated readings due to fluctuations in the source intensity. This second sensor also provides temperature compensation by forming a bridge network with the primary sensor. Because power conservation was of prime importance, a power converter rather than a resistor was used to drop the +6-volt dc battery supply voltage to that required by the lamp. The overall power required for the modified spirometer system, including the signal conditioner, is 96 milliwatts. Thus, use in limited power source applications such as battery-powered tape-recorder systems is possible.

CALIBRATION

The modified spirometer was calibrated to determine the response time and linearity of the system.

In order to determine response time, a pressure step function was applied by first flaming the balloon shown on the right in figure 6 and then, as quickly as possible, flaming the balloon shown on the left. A square wave pressure differential was thus

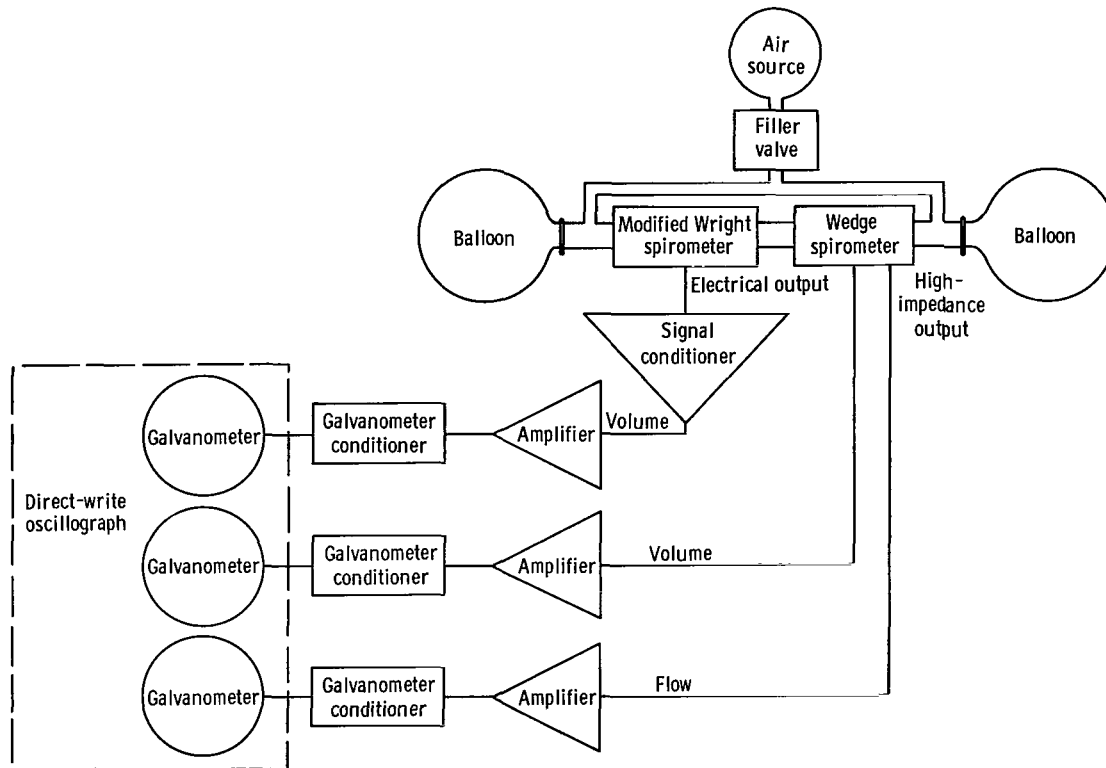

Figure 6.— Mechanical and electrical experimental setup for determining the response time of the modified Wright spirometer.

generated. The output pulses from the modified Wright spirometer and the output of the Wedge spirometer were recorded. A typical result from this experiment is shown in figure 7. The modified device is seen to accelerate to essentially steady-state angular motion in well under 1/10 second at the impressive flow rate of 150 liters/minute. This response is sufficiently fast that the time required for the rotor blade to reach steady-state rotation velocity is short with respect to the period of respiration. In fact, the time required for acceleration of the rotor blade to peak velocity was so short that, without further quantitative analysis, it is concluded that the response time of the system would not introduce appreciable error in volume or flow measurements when this device is used for routine human respiratory studies.

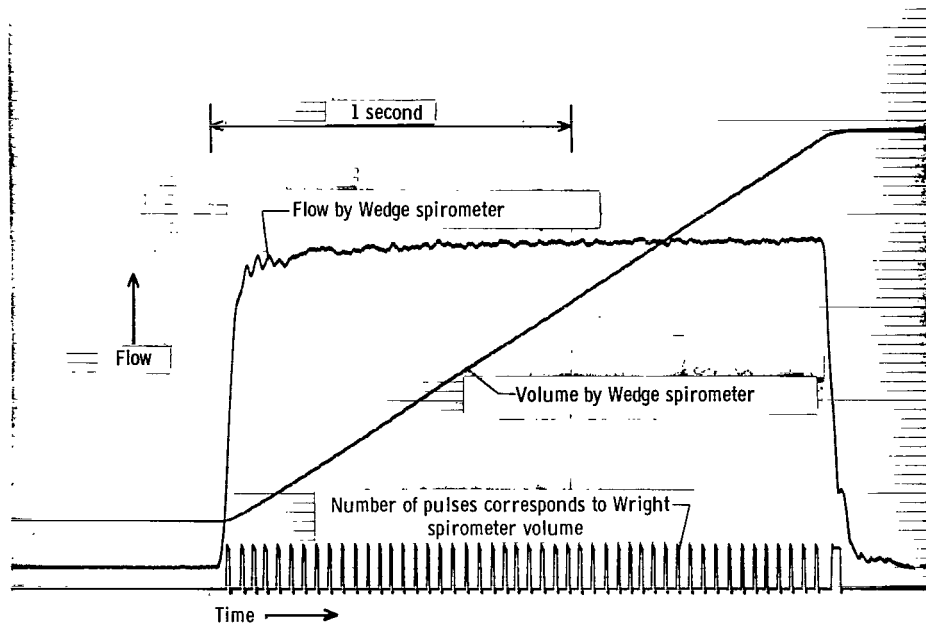

Figure 7.— Typical experimental data obtained with the setup diagramed in figure 6.

The linearity calibration was carried out using the experimental setup shown in figure 8. A Wedge spirometer was used as the standard for both flow and volume calibration. Mechanical inertia effects in the Wedge spirometer were minimized by making all measurements in steady flow. The Wedge spirometer provided electrical outputs for both volume and flow. In order to minimize scatter of Wright spirometer data due to the fact that the resolution of the modified Wright spirometer is only 0.1 liter, volume measurements were made on samples of not less than 10 liters. An unmodified Wright spirometer was inserted in series with the modified spirometer to determine what effect, if any, the mechanical modifications may have had on the linearity of the device.

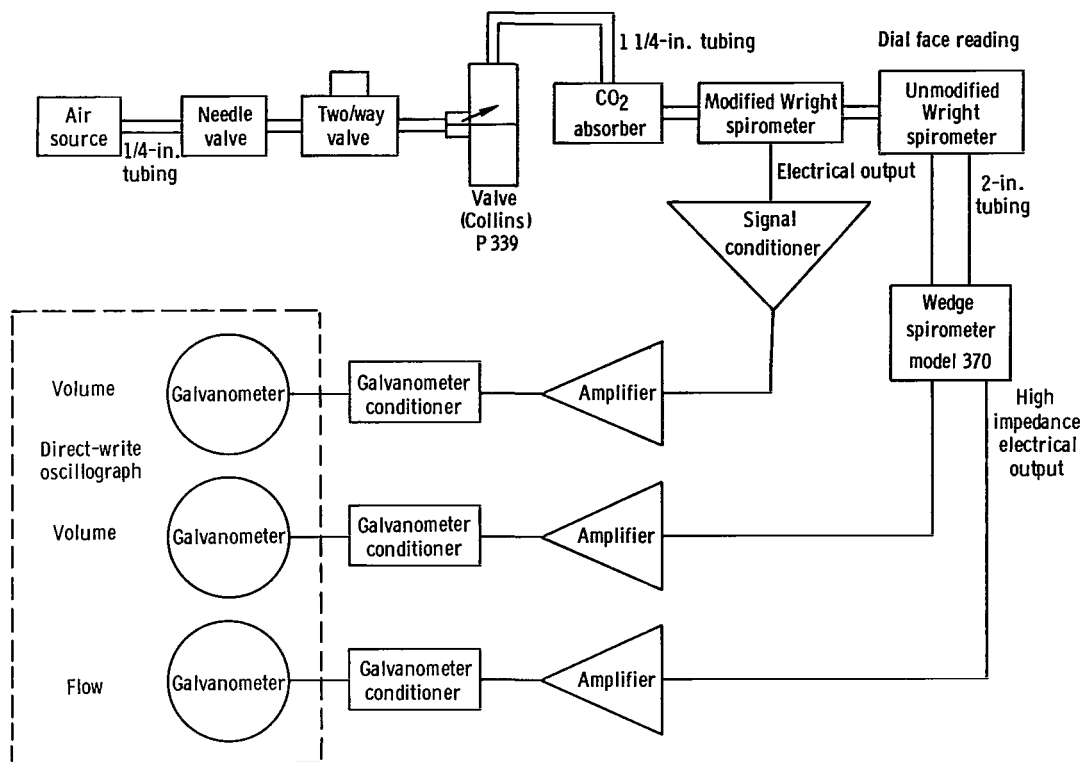

Figure 8.— Mechanical and electrical experimental setup for linearity calibration of the modified Wright spirometer.

The data obtained in this experiment are tabulated in tables I and II and presented in figures 9(a) and 9(b). As shown in the figures, nonlinear effects occur primarily at

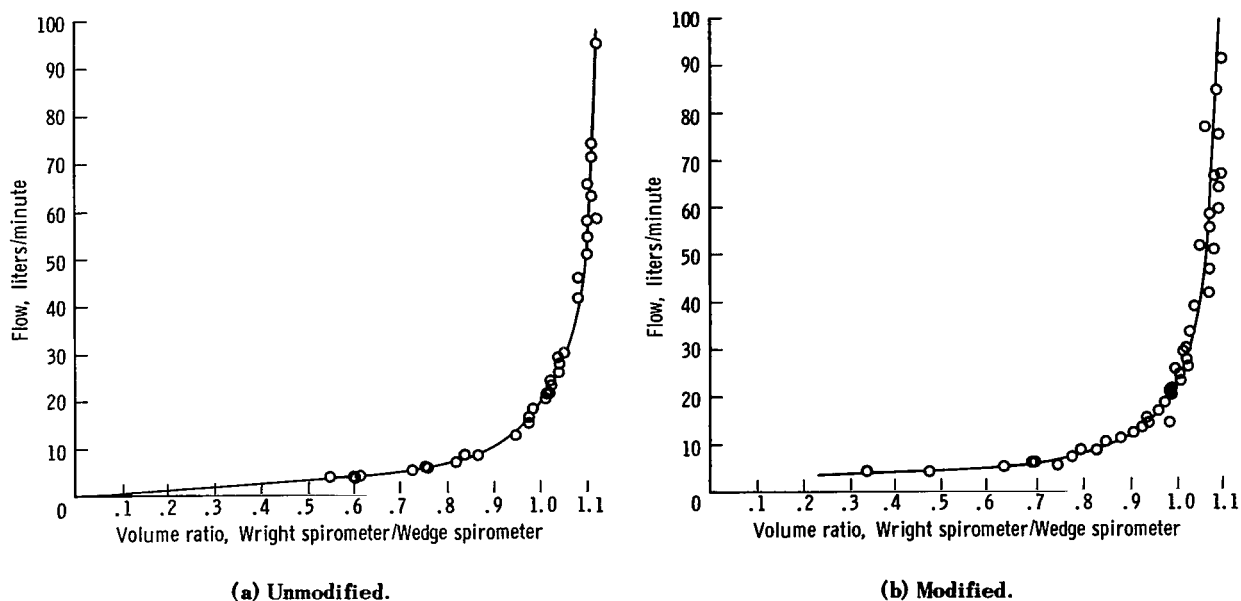

Figure 9.— Calibration curves for the unmodified and modified Wright spirometers.

flows of less than 20 liters per minute. For higher flow rates, the modified spirometer showed smaller error than the unmodified version, probably because of the decreased angular moment of inertia and reduction of friction in the gear train of the modified device, as a result of the removal of some of the moving parts. Using the calibration plot shown in figure 9(b), it is relatively simple to program the computer reduction of the electrical output of the modified flowmeter to provide automatic correction of output data, based on these instantaneous flow-rate values.

CONCLUDING REMARKS

As more and more monitoring is done on active patients, the demand will increase for small devices that can accurately measure respiratory flow, provide an output suitable for computer reduction of the information, and have a power drain sufficiently small to be supplied by batteries of self-contained tape recorders used to record the information. The modified Wright spirometer should provide a useful addition to the sensors available to those interested in dynamic monitoring.

Flight Research Center,
National Aeronautics and Space Administration,
Edwards, Calif., September 8, 1967,
127-49-06-02-24.

REFERENCE

1. Roman, James: Long-Range Program to Develop Medical Monitoring in Flight. The Flight Research Program-I, Aerospace Medicine, vol. 36, no. 6, June 1965, pp. 514-518.

TABLE I - UNMODIFIED SPIROMETER DATA

Spirometer			Volume ratio
Wedge		Wright	
Flow, liters/min	Volume, liters	Volume, liters	Wright spirometer/Wedge spirometer
3.63	0.915	0.550	0.600
3.70	3.960	2.160	.546
3.92	4.820	2.870	.596
4.07	3.750	2.300	.613
5.18	1.840	1.340	.727
5.40	3.490	2.640	.756
5.92	2.880	2.160	.750
6.82	5.160	4.200	.814
8.15	3.220	2.780	.864
8.30	3.750	3.130	.835
12.20	3.360	3.180	.947
14.49	3.690	3.610	.978
14.82	3.450	3.360	.974
16.10	4.140	4.030	.974
17.90	4.200	4.130	.983
19.80	3.920	3.950	1.010
20.75	4.140	4.180	1.010
21.10	3.820	3.890	1.020
22.60	4.050	4.140	1.024
23.70	4.360	4.440	1.020
25.30	4.370	4.530	1.037
26.80	4.280	4.440	1.038
26.85	4.100	4.230	1.032
28.30	4.020	4.170	1.038
29.30	4.340	4.570	1.050
33.82	3.940	4.210	1.067
41.04	4.100	4.420	1.078
42.50	4.440	4.830	1.089
45.60	4.100	4.440	1.080
48.40	4.750	5.125	1.079
50.50	4.070	4.470	1.100
53.88	4.080	4.500	1.100
55.00	4.660	5.120	1.099
57.30	3.910	4.290	1.100
57.90	3.920	4.400	1.120
62.34	4.200	4.680	1.110
65.04	4.510	4.950	1.100
65.20	4.380	4.820	1.090
70.80	4.180	4.630	1.110
73.49	4.210	4.680	1.110
94.56	4.220	4.730	1.120
107.90	5.360	6.070	1.134
128.64	3.770	4.290	1.130
132.00	4.070	4.630	1.130
132.00	4.040	5.050	1.130
160.28	4.000	4.600	1.150
171.50	5.600	6.530	1.166
193.00	5.370	6.170	1.150
195.50	4.590	5.300	1.150
214.00	5.900	6.760	1.146
216.12	4.520	5.160	1.140
231.36	4.250	4.870	1.140
238.20	5.050	5.340	1.060
241.50	5.930	6.850	1.165
265.98	4.490	4.820	1.075
287.00	6.760	7.710	1.140

TABLE II. - MODIFIED SPIROMETER DATA

Flow, liters/min	Spirometer		Volume ratio Wright spirometer/Wedge spirometer
	Wedge Volume, liters	Wright Volume, liters	
3.92	4.820	1.600	0.332
4.07	3.750	1.620	.460
5.03	1.300	.800	.615
5.18	1.840	1.160	.730
5.40	3.490	2.400	.688
5.92	2.880	1.970	.685
6.82	5.160	3.900	.760
8.15	3.220	2.600	.813
8.30	3.750	2.930	.780
10.31	2.020	1.700	.832
10.80	1.970	1.700	.864
12.20	3.360	3.000	.892
12.85	2.310	2.110	.908
13.75	3.360	3.100	.923
13.92	2.380	2.300	.966
14.82	3.450	3.200	.918
16.10	4.140	3.900	.944
17.90	4.200	4.000	.953
19.80	3.920	3.800	.970
20.30	3.210	3.100	.966
20.75	4.140	4.000	.966
21.10	3.820	3.170	.970
22.60	4.050	4.000	.990
23.70	4.360	4.300	.987
25.00	3.990	3.900	.978
25.30	4.370	4.400	1.005
26.80	4.280	4.300	1.003
28.30	4.020	4.000	.997
29.30	4.340	4.400	1.012
41.04	4.100	4.300	1.050
45.60	4.100	4.300	1.050
50.50	4.070	4.200	1.030
53.88	4.080	4.300	1.050
57.30	3.910	4.100	1.050
57.90	3.920	4.200	1.070
62.34	4.200	4.500	1.070
65.04	4.510	4.800	1.060
65.50	4.470	4.800	1.075
70.80	4.180	4.500	1.080
73.49	4.210	4.500	1.070
75.80	4.410	4.600	1.043
82.50	4.780	5.100	1.066
89.10	4.730	5.100	1.077
94.56	4.220	4.500	1.070
102.00	5.250	5.600	1.067
105.10	5.110	5.500	1.077
106.50	5.080	5.400	1.064
128.20	6.360	6.900	1.090
128.64	3.770	4.100	1.080
132.00	4.070	4.400	1.080
132.00	4.440	4.800	1.090
154.50	5.550	6.000	1.080
160.28	4.000	4.400	1.100
164.00	5.140	5.500	1.070
170.10	4.830	5.200	1.076
180.00	4.560	5.000	1.097
187.50	4.580	5.100	1.110
195.50	4.590	5.200	1.130
200.00	5.130	5.800	1.130
216.12	4.520	5.100	1.130
230.50	5.740	6.500	1.130
231.36	4.250	4.800	1.130
234.20	5.400	6.100	1.130
238.20	5.050	5.700	1.130
255.00	5.340	6.000	1.124
265.98	4.490	5.000	1.110

"The aeronautical and space activities of the United States shall be conducted so as to contribute . . . to the expansion of human knowledge of phenomena in the atmosphere and space. The Administration shall provide for the widest practicable and appropriate dissemination of information concerning its activities and the results thereof."

—NATIONAL AERONAUTICS AND SPACE ACT OF 1958

NASA SCIENTIFIC AND TECHNICAL PUBLICATIONS

TECHNICAL REPORTS: Scientific and technical information considered important, complete, and a lasting contribution to existing knowledge.

TECHNICAL NOTES: Information less broad in scope but nevertheless of importance as a contribution to existing knowledge.

TECHNICAL MEMORANDUMS: Information receiving limited distribution because of preliminary data, security classification, or other reasons.

CONTRACTOR REPORTS: Scientific and technical information generated under a NASA contract or grant and considered an important contribution to existing knowledge.

TECHNICAL TRANSLATIONS: Information published in a foreign language considered to merit NASA distribution in English.

SPECIAL PUBLICATIONS: Information derived from or of value to NASA activities. Publications include conference proceedings, monographs, data compilations, handbooks, sourcebooks, and special bibliographies.

TECHNOLOGY UTILIZATION PUBLICATIONS: Information on technology used by NASA that may be of particular interest in commercial and other non-aerospace applications. Publications include Tech Briefs, Technology Utilization Reports and Notes, and Technology Surveys.

Details on the availability of these publications may be obtained from:

SCIENTIFIC AND TECHNICAL INFORMATION DIVISION
NATIONAL AERONAUTICS AND SPACE ADMINISTRATION

Washington, D.C. 20546