

X-523-67-233

NASA TM X-63057

# GENERIC CONCEPTS OF THE AUTOMATED MULTIFUNCTIONAL RECEIVER

JOHN W. BRYAN

GPO PRICE \$ \_\_\_\_\_

CFSTI PRICE(S) \$ \_\_\_\_\_

Hard copy (HC) \$3.00

Microfiche (MF) .65

# 653 July 65

FACILITY FORM 602

N 68-13560 (ACCESSION NUMBER) \_\_\_\_\_ (THRU) \_\_\_\_\_

16 (PAGES) \_\_\_\_\_ (CODE) \_\_\_\_\_

TM X-63057 (NASA CR OR TMX OR AD NUMBER) \_\_\_\_\_ (CATEGORY) 07

APRIL 1967



GODDARD SPACE FLIGHT CENTER  
GREENBELT, MARYLAND

X-523-67-233

GENERIC CONCEPTS  
OF THE  
AUTOMATED MULTIFUNCTIONAL RECEIVER

By

John W. Bryan

April 1967

Goddard Space Flight Center  
Greenbelt, Md.

PRECEDING PAGE BLANK NOT FILMED.

TABLE OF CONTENTS

	<u>Page</u>
ABSTRACT . . . . .	v
INTRODUCTION . . . . .	1
OPERATION REQUIREMENTS . . . . .	2
Building Block Criteria . . . . .	3
Set Up Criteria . . . . .	4
Manual Control . . . . .	6
CALIBRATION AND TEST . . . . .	8
Phase I Receiver Calibrations . . . . .	8
Phase II Receiver Diagnostics . . . . .	10
MAINTENANCE AND REPAIR PHILOSOPHY . . . . .	11
ACKNOWLEDGMENTS . . . . .	11
REFERENCES . . . . .	12
FIGURES	
Flow Diagram . . . . .	5
Manual Control Keyboard . . . . .	7

PRECEDING PAGE BLANK NOT FILMED,

GENERIC CONCEPTS  
OF THE  
AUTOMATED MULTIFUNCTIONAL RECEIVER

By

John W. Bryan

ABSTRACT

This paper is a discussion of the general concepts of the Automated Multifunctional Receiver. The construction, operation, and maintenance criteria are explained without design details. The operational requirements of a single receiving system that will fulfill the needs of the Space Tracking and Data Acquisition Network (STADAN), the Manned Space Flight Network (MSFN), and the Deep Space Network (DSN) are enumerated. The RF circuitry of this receiver is very similar to that used in telemetry and ranging receivers. An explanation of computer-driven switches to set up the receiver and the use of test and monitor points to calibrate and diagnose receiver troubles are presented. Included are a flow diagram and a suggested manual control keyboard. Reports detailing design, construction, operations and maintenance will be published as development of the Automated Multifunctional Receiver proceeds.

# GENERIC CONCEPTS OF THE AUTOMATED MULTIFUNCTIONAL RECEIVER

## INTRODUCTION

This paper is concerned with the concepts of a fully Automated Multifunctional Receiver which will be used in the Space Tracking and Data Acquisition Network (STADAN), and the Manned Space Flight Network (MSFN). Functionally, this receiver will fulfill all receiver requirements for telemetry, auto-track, and ranging in STADAN, MSFN, and the Deep Space Network (DSN) of NASA.

The multifunctional or universal approach to receiver design and construction is not new. As early as 1940, voice communications, radar systems, and identification systems shared portions of a universal receiver. While the electronic circuitry does not depart radically from that used in many good receivers, the construction and automation concepts have led to fulfilling receiver requirements in a unique fashion. The new concepts as applied to this receiver are the RF building block approach and the automation features.

Several modular construction techniques have been developed for receivers in the past few years. However, these techniques do not utilize a building block concept as defined here. In this receiver, for example, we will use the same active amplifier block in many different portions of the receiver. This amplifier block may have a 20 db gain response flat from 5 MHz to 200 MHz. The block will be used as the active element in the 150 MHz intermediate frequency (IF) strip and also as the active element in the 18 MHz IF strip. Bandpass filters will be used to select the operating frequency. The same voltage controlled attenuator block will be used as a gain control element in both the above-mentioned IF strips. The same concept applies to mixers, detectors, etc.

The use of discrete, functional blocks lends itself to automation in that digital techniques can be readily used to select discrete values or units. For example, a digital word very easily selects the position of a switch. The automation feature proposed for the Automated Multifunctional Receiver is the selection of discrete circuit blocks by a digital computer. Computer-driven switches will connect the functional blocks in such a manner so as to form the desired receiver channel.

## OPERATION REQUIREMENTS

Early in the conceptual stages of the Automated Multifunctional Receiver, certain mission requirements were assumed. Some of these are:

1. Five telemetry links simultaneously with autotrack capability on each (MSFN requirements)
2. Variable predetection bandwidths (MSFN and STADAN requirements)
3. Demodulation of AM, FM, PM (MSFN and STADAN requirements)
4. Dual spacecraft tracking (STADAN and MSFN requirements)
5. Redundant capability of all functions (STADAN and MSFN requirements)
6. Operation in Unified S-band, Goddard Range and Range Rate, DSN ranging system
7. Operation in all telemetry bands from 135 to 4100 MHz
8. Closed loop (phase lock) and open loop operation
9. Computer or tape drive set up and calibration in three minutes or less

In conceiving a receiver which would fulfill these requirements, several added features resulted and were included. Some of these were:

1. Switch autotrack functions from one signal to another without loss of lock
2. Building block construction
3. Computer-driven malfunction diagnostics
4. Polarization tracking of incoming signal

To fulfill the requirement for five simultaneous telemetry channels and, at the same time, supply redundant capability requires six telemetry channels. One set of error channels capable of being switched to any sum channel will fulfill the autotrack requirement. However, the redundant capability requirement in autotrack will be fulfilled by using a second set of error channels. This also fulfills the requirement of simultaneous autotracking of two spacecrafts. Variable bandwidths are presently available in telemetry receivers so this requirement caused very little concern. All types of demodulation are available; however, the design concept is now to use one active element block with switchable circuitry to make a frequency modulation (FM) discriminator into a phase

modulation (PM) detector or coherent amplitude detector. To operate in any ranging system, phase delay must be maintained throughout the operational range. All filters must have linear phase characteristics. All local oscillators must be phase-stable and available for reconstruction of the received signal frequency. These requirements are met using the same specifications that apply to the present ranging receivers.

Local oscillators insofar as possible within the entire Automated Multifunctional Receiver will be generated by synthesizing from a frequency standard. The use of this frequency synthesis results in local oscillators which are as stable as the frequency standard used. Since each sum channel must be capable of independent tuning each sum channel will contain a variable frequency synthesizer. This synthesizer will be set as part of each channel set up procedure. The output frequencies of each synthesizer are also made available for doppler extraction processes.

The extremely wide signal bands will be covered in discrete steps. The concept here is to use separate preamplifiers/converters to convert the incoming signal at full bandwidth to the first intermediate frequency of the receiver. The received frequency bands are:

135 - 139 MHz	up converted to 398 to 402 MHz
400 - 410 MHz	(not converted)—400 to 410 MHz
1435 - 1535 MHz	down converted to 350 to 450 MHz
1700 - 1710 MHz	down converted to 395 to 405 MHz
2.2 - 2.3 GHz	down converted to 350 to 450 MHz
4.0 - 4.1 GHz	down converted to 350 to 450 MHz

The right hand column above shows the input frequency bands of the basic receiver. Each channel in the basic receiver is designed as a phase lock receiver having an input frequency of 350 to 450 MHz. This basic receiver channel should present no serious design problems.

#### Building Block Criteria

The Automated Multifunctional Receiver is conceived as a six-channel telemetry receiver with dual autotrack capability. This automatically set up, calibrated, and tuned receiver is conceived and designed to fulfill every tracking and data receiver requirement of STADAN and MSFN. The principal unique feature of this receiver is its "building block" construction. The receiver will be constructed of small submodules each containing a receiver component such as an amplifier, a mixer, a filter, a voltage controlled attenuator, and a demodulator. Each of these blocks is conceived as a general usage block. That is, the amplifier block will be an untuned, wideband amplifier having some nominal gain. The center frequency and bandwidth of an IF strip, for example, will not

be dependent on the active amplifier itself, but rather the filters ahead and/or behind it. Mixers will be untuned and capable of operating with a wide range of input frequencies and appropriate local oscillator frequencies, within limits, in order to generate desired output frequencies. Gain of any portion of the receiver will be controlled using voltage controlled attenuators, which will be as insensitive to frequency as possible. Even if the attenuation varies somewhat when used in different frequency bands, it may be possible to tailor the control voltage providing there is little variation from one unit to the next.

Bandwidth filters will be the only building blocks requiring the design characteristics of operating in a fixed frequency band. However, development may conceivably relax some of these stringent requirements through the use of varicaps.

The building block design concept makes possible lower logistic requirements which, in turn, means lower costs. Costs are further lowered by a reduction in cost of each submodule due to increased quantity requirements.

#### Set Up Criteria

The required receiver parameters for a particular mission will be stored within the station computer memory, on magnetic tape or some other external device which can be used to load the computer memory. This memory will not only contain the set up information but also calibration limits as established for particular receiver parameters. This program will contain all the station parameters so that the entire station can be set up and calibrated at one time.

The set up procedure for the receiver might be as follows (see Figure 1). The first computer word will select one of the following:

- Sum channel #1
- Sum channel #2
- Sum channel #3
- Sum channel #4
- Sum channel #5
- Sum channel #6
- X error channel #1
- Y error channel #1
- X error channel #2
- Y error channel #2
- Receiver calibrator and test station

The same word will instruct the selected channel as to what actions are to be done, such as, setting or reading parameter switches, and calibrating or testing the receiver.



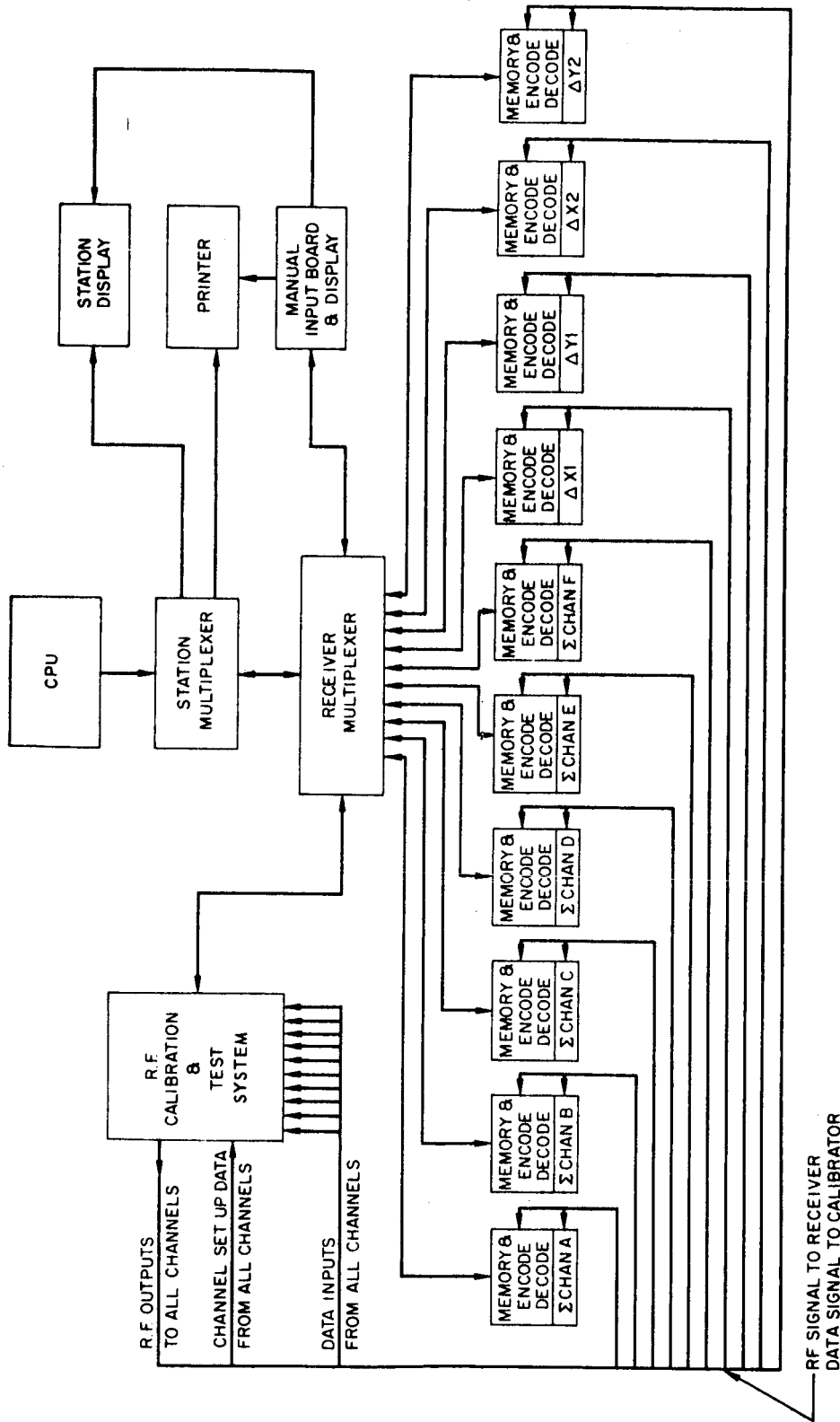

Figure 1-Receiver Control Flow Diagram

The instruction will cause the appropriate circuitry to be selected within the receiver multiplexer so that the procedure can continue. This circuitry will be held in this configuration until reset by a computer command. The computer can now feed subsequent words directly to the channel selected where they will be decoded according to the instructions received in the first word.

Since it will require 14 bits to set or read the synthesizer frequency, a special word from the computer will be required for this instruction. The synthesizer will have its own shift register to store input commands, and periodically up-dated shift register to store its output frequency. Thus, the synthesizer frequency will be available for computer readout whenever it is required.

The resulting position of each switch within the selected channel is encoded and is ready for read-out either by the computer or manual verification. This information is also required during the calibration and test procedures. This requirement is clarified in the Calibration and Test Section of this report.

The calibrator and test system has its own program built in and is simply addressed and told which program to run. This requires the calibrator to contain memory and a small computer.

### Manual Control

Occasionally, it may become necessary for the receiver operator/monitor to take manual control of the receiver, or call up for visual verification and test certain portions of the receiver. A manual control and display board is provided for this function. The manual input keyboard might be as shown in Figure 2<sup>1/</sup>. By depressing a button, which will light when depressed, the operator selects the portion of the receiver he wishes to display, manipulate or test.

Manual "call up" for display is accomplished in the following manner: The channel to be displayed is selected by depressing that particular button. The operator may now display a block diagram of this channel by depressing the "line diagram" button. The selected circuit parameters will be included in this block diagram. However, if just a portion of a channel is desired, the operator will depress the button for only that parameter. The diagrams and values presented in this display are dependent on parameter switch positions within the receiver and not necessarily actual circuit parameters.

---

<sup>1/</sup>Blank keys are included to allow for additional operations which will become evident as development of the receiver proceeds.

	DISPLAY INSTRUCTIONS		CALIBRATOR INSTRUCTIONS	COMPUTER INSTRUCTIONS	
CHANNEL A	FREQUENCY BAND	INPUT FREQUENCY	AGC VS POWER INPUT	AM	10
CHANNEL B	2ND I.F. BANDWIDTH	AGC VOLTS	BIT ERR/RATE VS INPUT S/N	FM	30
CHANNEL C	3RD I.F. BANDWIDTH	ERROR VOLTAGE $\Delta X\#1$	CHANNEL NOISE FIGURE	PM	100
CHANNEL D	PRIMARY LOOP BANDWIDTH	ERROR VOLTAGE $\Delta X\#2$	BANDWIDTH PLOT	OPEN LOOP	300
CHANNEL E	SECONDARY LOOP BANDWIDTH	ERROR VOLTAGE $\Delta Y\#1$	CHANNEL CALIBRATE	CLOSED LOOP	1000
CHANNEL F	DEMODULATOR (WIDE BAND)	ERROR VOLTAGE $\Delta Y\#2$	CHANNEL DIAGNOSTICS	CONNECT ERROR CHANNEL #1	FREQUENCY SEARCH
CHANNEL $\Delta X\#1$	WIDE BAND POST DETECT BANDWIDTH	LINE DIAGRAM		CONNECT ERROR CHANNEL #2	DOPPLER PROGRAM
CHANNEL $\Delta Y\#1$	DEMODULATOR NARROW BAND				
CHANNEL $\Delta X\#2$	NARROW BAND POST DETECT BANDWIDTH				
CHANNEL $\Delta Y\#2$	LOOP MODE OL/CL				

Figure 2—Manual Control Panel

To display actual circuit parameters, the receiver calibrator must be called into the circuit. A limited number of channel or parameter calibrations and tests may be accomplished from the manual keyboard. These are shown in Figure 2 under "calibrator instructions." Once again the channel, and, if desired, a parameter must be selected prior to depressing the "calibrator instruction" button. This selection of buttons; i.e., channel, parameter, and calibrator instruction will result in the display of actual circuit parameters based upon the results of a programmed test run by the receiver calibrator. The operator may also trouble shoot, to the module level, any channel by depressing that channel and the "channel diagnostics" button. This selection will cause the receiver calibrator to generate test frequencies and insert them at test points within the receiver. The signals from appropriate monitor points within the receiver will be fed back to the calibrator and compared with programmed values by the station computer. At the same time, a modular diagram will be displayed on the display panel. If the signal from any monitor point does not agree with the programmed value, an indication of trouble will be given on the display.

To change the configuration of the receiver requires a message from the station computer. The computer is informed of the desired change by the operator depressing the designated buttons for the channel desired, the parameter, and the computer instruction, in that order. The computer will now perform the indicated change. This instruction will also cause the display to show the block diagram indicating the change only after it has been made. The computer instruction section of the keyboard is also used to initiate the computer generated program such as "programmed doppler."

## CALIBRATION AND TEST

The calibration and test program is divided into Phase I (calibration) and Phase II (testing). Phase I will be run every time the receiver is reconfigured and immediately prepass for every mission. Phase II will be run only if any portion of the receiver fails Phase I and then only on that channel or channels which fail.

### Phase I Receiver Calibration

The receiver calibration is accomplished in four discrete tests.

1. Receiver sensitivity  
 $P_{in}$  versus AGC

2. Bandwidth  
Center band versus 3 db points
3. Bit errors  
Bit error rate versus signal-to-noise ratio
4. Autotrack  
Degrees off boresight versus error voltage.

To accomplish the first calibration step, the computer will address the calibration station directly, setting the following calibration pattern:

1. Channel to be calibrated
2. Test to run (AGC versus power input)

Switches within the calibrator will then lock up to the selected channel and thus receive the following information from the receiver:

1. Center frequency
2. Predetection bandwidth
3. Post detection bandwidth
4. AGC speed
5. Set of error channels in use

With the above information, the calibrator will now supply to the receiver preamp input, a continuous wave signal (calibrator generated) at center frequency and proceed to step through several RF power levels. The minimum power level will be the receiver channel threshold. The digitized AGC voltage will be fed back to the calibrator, after the appropriate time has elapsed, and stored. (The elapsed time will be selected by the calibrator in accordance with the AGC speed.) The input power level, at each step, along with the appropriate AGC voltage will be stored in the calibrator output buffer for comparison with the acceptable levels by the computer.

When this information has been read out by the computer, the calibrator will proceed to a bit error versus signal-to-noise ratio test. For this test, the calibrator will generate the appropriate carrier and subcarrier frequencies, without subcarrier modulation, until the loops are locked for coherent

demodulators. (This signal will be fed into the receiver preamp.) When the loops have locked, the receiver will signal the calibrator to proceed with the test. The calibrator will now modulate the subcarriers and/or carrier with an appropriate bit stream. The calibrator-generated bit rate shall be commensurate with the receiver bandwidth. A program within the calibrator causes the errors to be counted for a predetermined time at each of several different signal-to-noise ratios above threshold. The signal-to-noise ratio and its respective bit error rate will be stored in the calibrator output buffer for correlation with the theoretical curve by the computer.

Autotrack accuracy will be calibrated without the antenna. The proper level signals will be generated by the calibrator and fed into the sum and difference channels of the receiver. The error voltages and the polarity of the error voltages generated by these signals will be stored in the calibrator output buffer for correlation with the correct or expected values by the computer.

Upon completion of Phase I, the computer will render a go, no-go decision based on stored tolerances within the computer memory. The data from the above three tests will be recorded at the beginning of the mission message tape. If desirable, the same tests could be made at the end of a mission and recorded at the end of the mission message tape.

### Phase II Receiver Diagnostics

If the computer, through the comparison process, has made a no-go decision on any channel, the computer will instigate Phase II tests on that channel. In the Phase II tests, the calibrator will supply test signals to each module within that channel in a sequence to be determined after the final module configuration has been established. The characteristics of this signal will be such that gain (or loss), bandwidth, operating level, and distortion, etc., can be detected and stored in the calibrator in digital format. Upon receiving an actuating signal from the calibrator, the computer will sample the respective module outputs. The computer will compare these samples to values in memory. From the above information the computer will print out the module or modules failing Phase II and the manner failed, i.e., low gain, incorrect bandwidth, etc.

Armed with this printout, a technician will replace, from the spare module file, the entire module and start the procedure to recalibrate that channel. The replaced module will be repaired in accordance with procedures contained in the logistics and repair section of this report.

## MAINTENANCE AND REPAIR PHILOSOPHY

The maintenance and repair of the Automated Multifunctional Receiver is done with the aid of the site computer and an automatic test facility. As started under the set up criteria, a malfunctioning module will be tagged as to the cause of rejection only.

The automated test facility will be physically located in an area separated from the operations area. This facility will be equipped with signal generators, voltmeters, ammeters, oscilloscopes, spectrum analyzer and other assorted instruments required to test any module. The repair personnel will open the module, exposing the submodules and associated wiring. Test terminals will be built into the module so that each individual submodule can be tested according to its function. Connectors from the test station will be fastened to these appropriate test points in the module which then will be plugged into the test set.

All test equipments will be connected via programmable switching arrangements whereby programming equipment (punched cards) can operate the test equipments and the module. These cards will initiate tests of each submodule presenting the results on the appropriate indicators. On the basis of these results, the repairman will cause the test station to move to the next test. There will probably be one card for each submodule or each test. Thus, each submodule will be entirely tested for operating characteristics and the results presented so that the repairman can make a go, no-go decision on each submodule.

When the malfunctioning submodule is located it will be replaced in its entirety. The repairman will then calibrate the module according to the published criteria adjusting gains, bandwidths, signal levels, etc. The module is once again run through the entire test procedure to ascertain that it now fulfills all the operational specifications. When the module has met these specifications, it is returned to the spare module file. All spare modules will be periodically run through this specification test to insure operational readiness.

## ACKNOWLEDGMENTS

A universal receiver for use in the STADAN was proposed by Mr. H. W. Shaffer of the Network Engineering and Operations Division. The author also wishes to acknowledge the efforts by Mr. Shaffer in supplying impetus to this program. The suggestions and advice of Mr. Victor R. Simas, his staff in the RF Systems Branch, members of the Space Data Control Branch, and the many engineers in the Network Engineering and Operations Division are gratefully acknowledged.

## REFERENCES

1. Shaffer, H. W.: A Universal Receiver for the STADAN. GSFC X-530-66-144, July 1965.
2. Shawe, Merrick E.: Station Automation. GSFC X-521-66-168, April 1966.
3. Taylor, Ralph E.: Advanced Polarization Diversity Autotrack Receiver (APDAR) 136 Mc Satellite Tracking Evaluation Tests. GSFC X-523-66-42, February 1966.