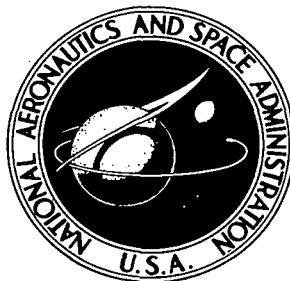


NASA TECHNICAL NOTE



NASA TN D-4342

c-1

NASA TN D-4342

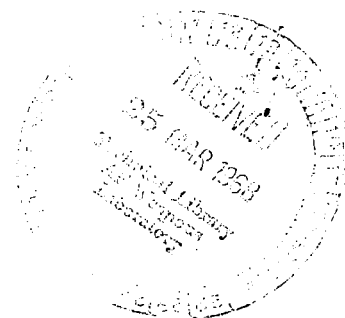
**LOAN COPY:
AFWL (C)
KIRTLAND AFB**



TO

**COMPUTING PROGRAM FOR
AXIAL DISTRIBUTION OF
AERODYNAMIC NORMAL-FORCE
CHARACTERISTICS FOR AXISYMMETRIC
MULTISTAGE LAUNCH VEHICLES**

*by Ragan B. Madden
Langley Research Center
Langley Station, Hampton, Va.*



ERRATA No. 2

NASA Technical Note D-4342

COMPUTING PROGRAM FOR AXIAL DISTRIBUTION OF AERODYNAMIC
NORMAL-FORCE CHARACTERISTICS FOR AXISYMMETRIC
MULTISTAGE LAUNCH VEHICLES

By Ragan B. Madden

March 1968

Page 59, after line 14: Add the statement NN3=0

Page 60, after line 2: Add the statements NN2=0
NN3=0

ERRATA

NASA Technical Note D-4342

COMPUTING PROGRAM FOR AXIAL DISTRIBUTION OF AERODYNAMIC
NORMAL-FORCE CHARACTERISTICS FOR AXISYMMETRIC
MULTISTAGE LAUNCH VEHICLES

By Ragan B. Madden

March 1968

Page 84, the first three lines following LAM4(3,J), J=1,42 should be

.320	.260	.200	.278	.228	.175	.238	.198	.152	.200
.168	.132	.168	.142	.113	.139	.120	.098	.116	.102
.083	.099	.088	.073	.083	.077	.062	.072	.067	.055

Page 85, the first line following LAM4(4,J), J=1,42 should be

.278	.239	.200	.239	.211	.172	.200	.184	.148	.170
------	------	------	------	------	------	------	------	------	------

TECH LIBRARY KAFB, NM



0131487

COMPUTING PROGRAM FOR AXIAL DISTRIBUTION OF AERODYNAMIC
NORMAL-FORCE CHARACTERISTICS FOR AXISYMMETRIC
MULTISTAGE LAUNCH VEHICLES

By Ragan B. Madden

Langley Research Center
Langley Station, Hampton, Va.

NATIONAL AERONAUTICS AND SPACE ADMINISTRATION

For sale by the Clearinghouse for Federal Scientific and Technical Information
Springfield, Virginia 22151 - CFSTI price \$3.00



CONTENTS

<u>SUMMARY</u>	1
<u>INTRODUCTION</u>	1
<u>SYMBOLS</u>	2
<u>APPLICATIONS</u>	6
<u>USERS' SECTION</u>	9
CONFIGURATIONS	9
CASE INPUT	13
Restrictions on Case Input	14
Considerations Which Should Be Given to Case Input	15
Case Input Data Cards Description	16
First data card	17
Second data card	17
Third data card	17
Fourth data card	17
Fifth data card	18
Sixth data card	18
Seventh data card	18
Eighth data card	18
First set of data cards following first eight single data cards	19
Second set of data cards following first eight single data cards	19
Last set of data cards	19
OUTPUT	20
<u>PROGRAMERS' SECTION</u>	29
PROGRAM LOGIC	29
COMPUTER PROGRAM	35
METHOD OF INPUTTING FIXED INPUT DATA	35
Component 1	38
Components 2, 4, 5, and 8	39
Component 3	39
Component 6	39
Component 7	39
<u>CONCLUDING REMARKS</u>	43
<u>APPENDIX A - PROGRAM LISTING</u>	45
<u>APPENDIX B - FIXED INPUT DATA LISTING</u>	75
<u>REFERENCES</u>	122

COMPUTING PROGRAM FOR AXIAL DISTRIBUTION OF AERODYNAMIC
NORMAL-FORCE CHARACTERISTICS FOR AXISYMMETRIC
MULTISTAGE LAUNCH VEHICLES

By Ragan B. Madden
Langley Research Center

SUMMARY

This report describes a digital computer program which calculates the axial distribution of aerodynamic normal-force characteristics for axisymmetric, multistage launch vehicles in the linear angle-of-attack range. In calculating these characteristics for a particular configuration the program utilizes available experimental data, the majority of which were obtained from NASA Technical Note D-3283 and Lockheed Missiles & Space Company report LMSC/HREC A712618. These data cover a wide range of Mach numbers and geometric parameters and can be readily utilized to obtain similar characteristics for most launch-vehicle configurations.

INTRODUCTION

The increased demand upon the aeroelastician to obtain the distributed aerodynamic normal-force loads for launch-vehicle configurations necessitated the development of a digital computer program to calculate these force coefficients.

A large amount of experimental data for the components comprising most launch vehicles were obtained from references 1 and 2. These data were reduced to a standard form and employed in the program as fixed input data. In obtaining the characteristics for a particular vehicle, the program considers the individual components which comprise the vehicle and performs linear interpolations or extrapolations on the proper fixed input data values.

The methods of reducing the data to a standard form and the limitations on these methods are described in reference 1, which should be used in conjunction with this program.

This report consists of two main parts. The first part is the users' section which is to be referred to when one wants to obtain the characteristics for a particular vehicle. This part describes the input and the output, and two examples are given in order to illustrate the use of the program. The second part is the programmer's section which describes

the program logic and the method of inputting the fixed data. If one is just interested in using the program to obtain the characteristics for a particular vehicle, then this part of the report need not be referred to. Also included are the program listing and the fixed input data listing as appendixes A and B, respectively.

SYMBOLS

When components are mentioned in series, they are to be considered in sequence from nose to aft end.

- A experimentally determined coefficient to determine λ values for a sphere
- A1 denotes values of interpolated λ values at $(f_a)_r$ and at each $\left(\frac{x}{D_o}\right)_{k2}$ value in figure 10; denotes values of interpolated λ values at $(\theta_f)_r$ and at each $\left(\frac{x}{D_o}\right)_{k2}$ values in figure 11
- A2 denotes interpolated λ values at $(\theta_f)_r$ and at each $\left(\frac{x}{D_o}\right)_{k2}$ value in figure 10; denotes interpolated λ values at $\left(\frac{D_1}{D_o}\right)_r$ and at each $\left(\frac{x}{D_o}\right)_{k2}$ value in figure 11
- A3 denotes interpolated λ values at $(\theta_n)_r$ and at each $\left(\frac{x}{D_o}\right)_{k2}$ value in figure 10
- A4 denotes final interpolated λ values at M_r and at each $\left(\frac{x}{D_o}\right)_{k2}$ value
- A44 denotes interpolated λ values at $(\theta_n)_r$ and at each $\left(\frac{x}{L}\right)_{k2}$ value in figure 9
- C_N normal-force coefficient, F_N/qS
- C_{N_α} normal-force-coefficient slope, $\frac{\partial C_N}{\partial \alpha}$, per radian
- D local diameter, meters

D_0	reference diameter, meters
D_1	reference diameter of first frustum, meters
D_2	reference diameter of second frustum in multistage vehicle, meters
D_3	reference diameter of third frustum in multistage vehicle, meters
D_4	reference diameter of fourth frustum in multistage vehicle, meters
$DX4$	diameter of second cylinder of ogive-cylinder-cylinder combination, meters
$DX5$	diameter of second cylinder of a cone-cylinder-cylinder combination, meters
$DX7$	diameter of second cylinder of a frustum-cylinder-cylinder combination, meters
$(D_1/D_0)_i$	reference diameter of ith frustum divided by reference diameter of cylinder following ith frustum
$D\lambda$	product of local diameter and generalized loading function, referred to in this report as load characteristics, meters per radian
F_N	normal force, newtons
f_a	fineness ratio of cylinder preceding frustum
f_n	fineness ratio of tangent ogive
L	length of component under consideration, meters

M	mach number
l	length of sharp ogive preceding cylinder or length of cylinder preceding frustum, meters
q	dynamic pressure, newtons per meter ²
R	planview radius of ogive, meters (see fig. 5(b))
r	one-half reference diameter of ogive, meters
S	reference area, meters ²
x	local body axial coordinate of component, $\mu - \mu_0$, meters
X1	junction point of cylinder and following frustum, meters
X2	junction point of frustum and following cylinder, meters
XR1C	junction point of cone-cylinder or ogive-cylinder, meters
XR4	μ coordinate at which second cylinder of ogive-cylinder-cylinder combination begins, meters
XR5	μ coordinate at which second cylinder of cone-cylinder-cylinder combination begins, meters
XR7	μ coordinate at which second cylinder of frustum-cylinder-cylinder combination begins, meters

- $S \frac{dC_{N\alpha}}{dx}$ product of reference area and distributed normal-force-coefficient slope,
meters per radian
- α angle of attack, radians
- θ_b boattail angle, degrees
- $\theta_{f,i}$ ith frustum angle where, in multistage vehicle, ith frustum is defined to be
closer to nose than i + 1st frustum
- θ_n cone semivertex angle, degrees
- λ generalized loading function, $\frac{1}{D} S \frac{dC_{N\alpha}}{dx}$, per radian
- μ axial coordinate of launch vehicle (or configuration), meters
- μ_0 value of μ at origin of component under consideration such that locally
 $x = \mu - \mu_0$, meters

Subscripts:

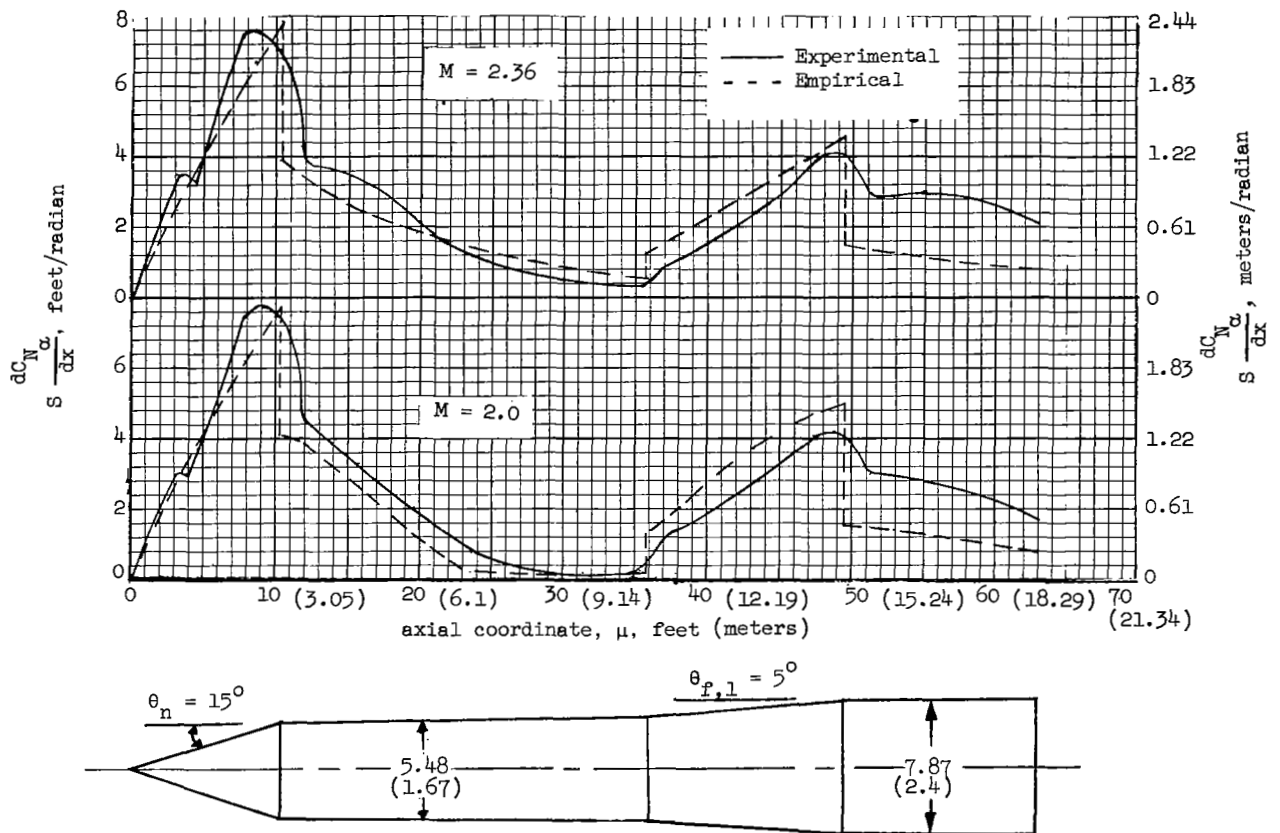
- i,j,k denote fixed input variables in figures 9, 10, and 11
- k2 ranges over number of case input x stations for a given component
- n nose
- r case input variable in figures 9, 10, and 11

T tangency point

1,2 denote the first and second interpolations, respectively, at a given case input variable in figures 9, 10, and 11

APPLICATIONS

A comparison of load characteristics from experimental and empirical data for a typical launch vehicle is shown in figure 1. Empirical load characteristics for typical launch vehicles are shown in figure 2.



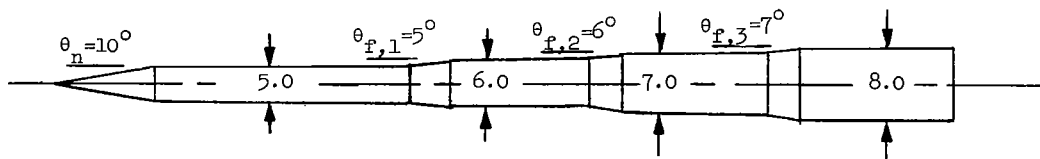
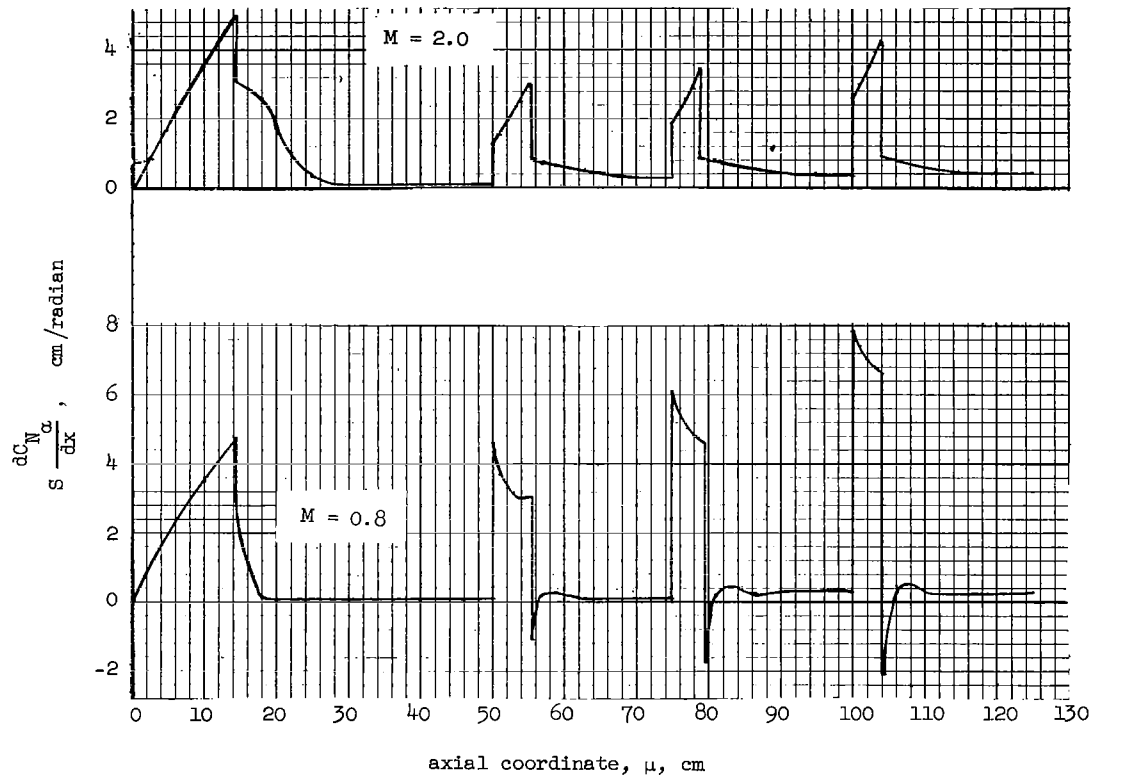


Figure 2.- Empirical load characteristics for typical launch-vehicle configurations.

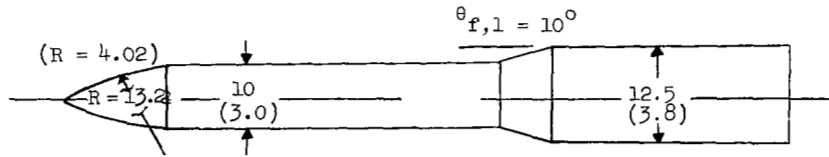
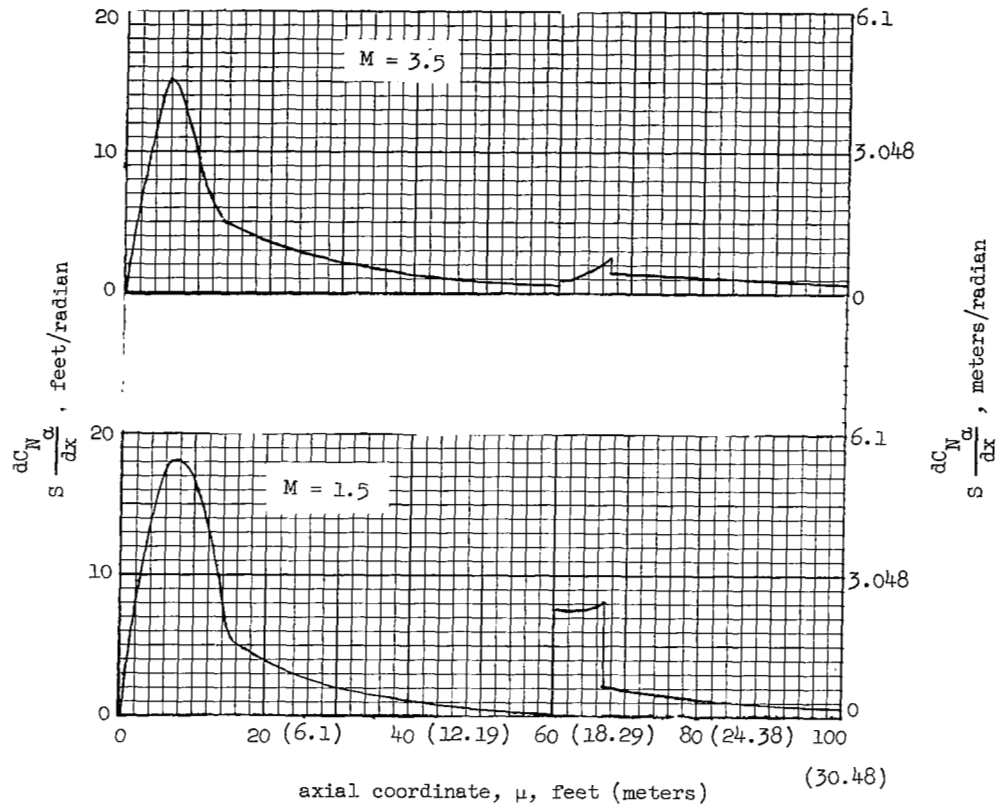


Figure 2.- Concluded.

USERS' SECTION

CONFIGURATIONS

From references 1, 2, and 3, λ values for eight basic components were obtained. These values are read into the program as fixed input data each time the program is used. The description of the components, the component code numbers, and the parameter and Mach number ranges covered by these λ values are shown in table I. The solid-line components in table I are the components of interest, and the dashed-line components are the components which precede the components of interest.

TABLE I.- COMPONENTS FOR WHICH LOADING FUNCTIONS (λ VALUES) ARE AVAILABLE
AND PARAMETER AND MACH NUMBER RANGES COVERED

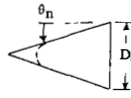
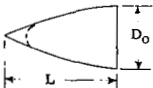

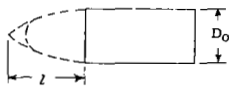

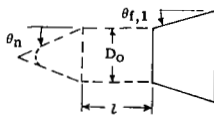
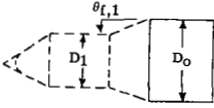
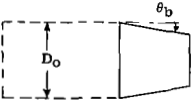
Component	Diagram of component	Parameter range	Mach number range
1 Cone - sharp or blunted		$0^\circ \leq \theta_n \leq 50^\circ$	0.70 to 15.00
2 Tangent ogive - sharp or blunted		$0.50 \leq (l_n = L/D_0) \leq 6.0$	0.80 to 15.00
3 Sphere			0.25 to 15.00
4 Cylinder following sharp or blunted tangent ogive		$3 \leq (l_n = l/D_0) \leq 7.0$	3.00 to 15.00
5 Cylinder following sharp or blunted cone		$0^\circ \leq \theta_n \leq 40^\circ$	0.70 to 15.00
6 Frustum following sharp or blunted cone - cylinder		$15^\circ \leq \theta_n \leq 30^\circ$ $0^\circ \leq \theta_{f,1} \leq 20^\circ$ $0 \leq (l_n = \frac{l}{D_0}) \leq 4$	0.80 to 15.00
7 Cylinder following cone-cylinder-frustum		$0^\circ \leq \theta_{f,1} \leq 20^\circ$ $0 \leq (D_1/D_0)_1 \leq 1$	0.80 to 15.00
8 Boattail following cylinder at aft end		$0 \leq \theta_b \leq 16^\circ$	1.50 to 15.00

Figure 3 shows the geometric parameters which are used in defining the eight basic components, and figure 4 shows five variations of the eight basic components for which the program may be used. The solid and dashed lines in figures 3 and 4 have the same significance as in table I.

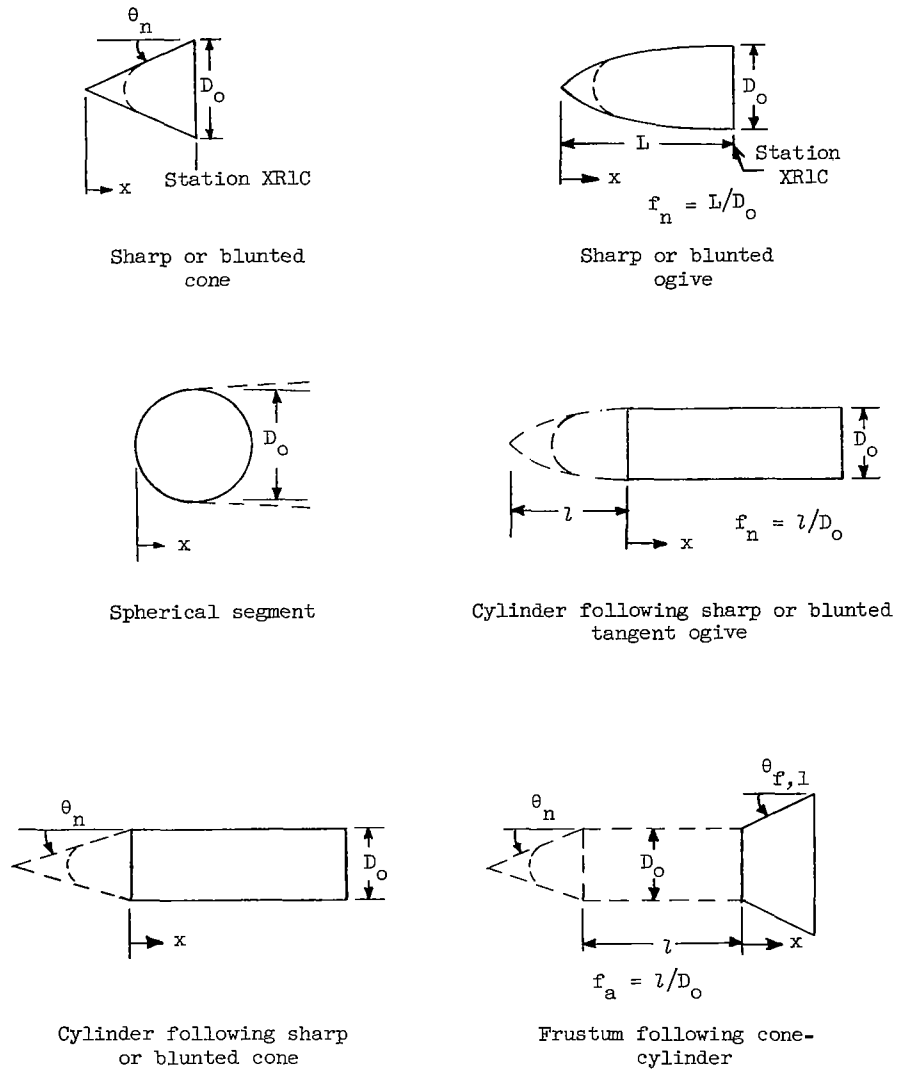
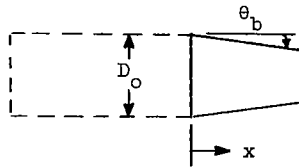
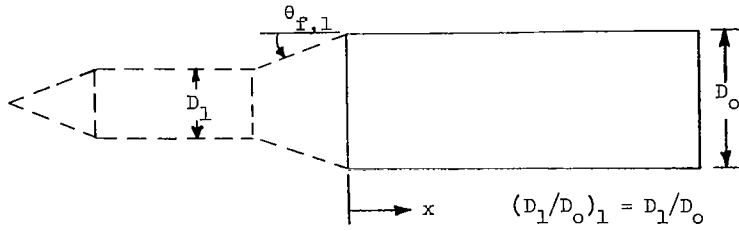


Figure 3.- Parameters used to define geometrical components.

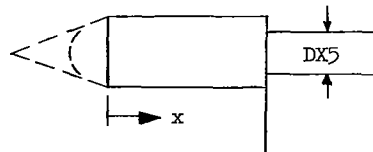


Boattail following cylinder at aft end



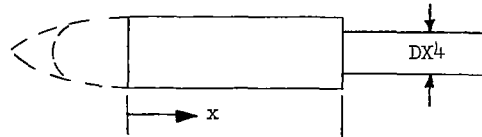
Cylinder following cone-cylinder-frustum

Figure 3.- Concluded.



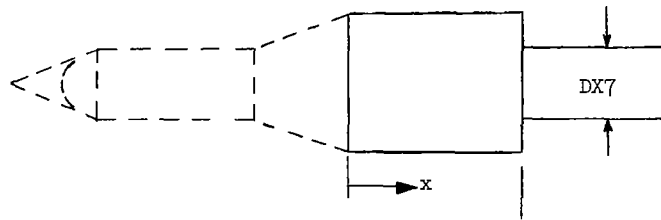
Station XR5

Variation I: Cylinder-cylinder following cone



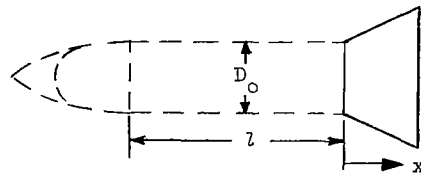
Station XR4

Variation II: Cylinder-cylinder following ogive

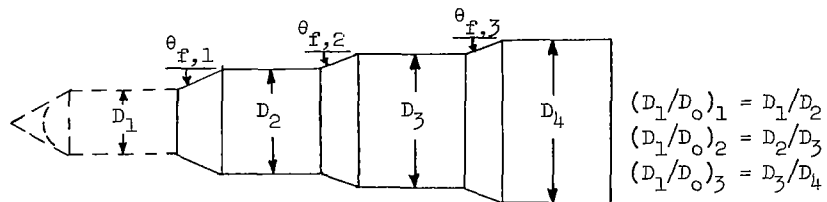


Station XR7

Variation III: Cylinder-cylinder following frustum



Variation IV: Frustum following ogive-cylinder
(Restricted to $f_a = l/D_o \geq 4.0$)



Variation V: Multifrustum-cylinder combinations

Figure 4.- Five variations of components 4, 5, 6, and 7 and associated parameters.

CASE INPUT

This section gives the method of inputting data for a particular vehicle to the program. Table II gives the FORTRAN names of the input variables and the definitions of each variable.

TABLE II.- FORTRAN NAMES AND DEFINITIONS FOR CASE INPUT DATA

FORTRAN name	Definition
COMPNO(I)	Component code numbers, beginning with component at nose, I = 1 to NCMP5; see table I and restrictions (5) and (6)
DDRR(J)	$(D_1/D_0)_J$, J = 1 to NFCYCM; the reference diameter of Jth frustum divided by reference diameter of cylinder following Jth frustum; see figures 3 and 4
DO(I)	Reference diameter D_0 of each component, beginning with component at nose, I = 1 to NCMP5; see figure 3
DX4	DX4, diameter of second cylinder of ogive-cylinder-cylinder combination; see figure 4
DX5	DX5, diameter of second cylinder of cone-cylinder-cylinder combination; see figure 4
DX7	Diameter of second cylinder of frustum-cylinder-cylinder combination; see figure 4
FAR	f_a , fineness ratio of cylinder preceding frustum; see figure 3 and restriction (8)
FNR	f_n , fineness ratio of sharp tangent ogive; see figure 3 and restriction (13)
MACHN(K)	Mach numbers at which $D\lambda$ values are desired, K = 1 to NMACHN; see restriction (1)
NC1	Input as 1 if variation I exists and input as 0 otherwise; see figure 4 and restriction (6)
NC2	Input as 1 if variation II exists and input as 0 otherwise; see figure 4 and restriction (6)
NC3	Input as 1 if variation III exists and input as 0 otherwise; see figure 4 and restriction (6)
NCMP5	The number of components which comprise the vehicle; see restrictions (5) and (6)
NDX	Input as 0 if stations are to be input from nose to aft end in ascending order and input as 1 if stations are to be input from nose to aft end in descending order
NFCYCM	The number of frustum-cylinder combinations; see restriction (7)
NMACHN	The number of Mach numbers; see restriction (1)
NOXS	The number of stations; see restriction (2)
NPUNCH	Input as 0 if no punch card output is desired and input as 1 if punch card output is desired
NTHFRR	The number of frustum angles θ_f ; see restriction (7)
NXS(I)	The number of x stations of component I, beginning with component at nose, I = 1 to NCMP5; see restriction (4)
THBR	θ_b , boattail angle in degrees; see figure 3
THFRR(N)	$\theta_{f,n}$, Nth frustum angle in degrees, beginning with frustum closest to nose, N = 1 to NTHFRR; see figures 3 and 4 and restriction (7)
THNR	θ_n , cone semivertex angle in degrees; see figure 3
XR1C	XR1C, junction station of cone-cylinder or ogive-cylinder; see figure 3
XR4	XR4, μ coordinate at which second cylinder of an ogive-cylinder-cylinder combination begins; see figure 4
XR5	XR5, μ coordinate at which second cylinder of a cone-cylinder-cylinder begins; see figure 4
XR7	XR7, μ coordinate at which second cylinder of a frustum-cylinder-cylinder begins; see figure 4
XS(M)	μ coordinates at which $D\lambda$ values are desired, beginning with station at nose, M = 1 to NOXS; see restrictions (2) and (3)

Restrictions on Case Input

The following restrictions apply to the case input:

- (1) A maximum of 15 Mach numbers may be input.
- (2) A maximum of 350 coordinates overall may be input, and they must be input from the nose to the aft end in either ascending or descending order. These stations are the XS(I) values defined in table II.
- (3) At junction points of components – excluding variations I, II, and III – the associated stations must be input twice in the XS(I) set of case input. At junction points of variations I, II, and III – that is, at stations XR4, XR5, and XR7 – the stations are input once on the fourth case input data card and once in the XS(I) set of case input.
- (4) A maximum of 100 stations for an individual component may be input.
- (5) The component code numbers COMPNO(I) refer only to the eight basic components shown in table I. It should be understood that a blunted cone is composed of components 3 and 1 and a blunted ogive is composed of components 3 and 2. The cylinder-cylinder combination for variations I, II, and III is treated as a single component – that is, for variation I, the cylinder-cylinder combination is component 5; for variation II, component 4; and for variation III, component 7. The presence of variations I, II, or III in a vehicle is denoted by the value of the case input variables NC1, NC2, and NC3, respectively, on the second case data card. Variation IV is just a particular arrangement of some of the eight basic components. The presence of variation V in a vehicle is denoted by the value of the case input variable NFCYCM on the second case data card. The values of COMPNO(I) must always identify the components taken in sequence from the nose to the aft end, and the value of NCMPS must be less than 15.
- (6) A vehicle is not allowed to be composed of two or more variations of the same type. As an example, a vehicle is allowed to have one variation I and one variation II but is not allowed to have two variations I.
- (7) The number of frustum-cylinder combinations may not exceed five. If there are no such combinations or only one such combination, the value of the case input variable NFCYCM must be 1. Also, the number of frustums may not exceed five. If there are no frustums or only one frustum, the value of the case input variable NTHFRR must be 1.
- (8) If more than one frustum-cylinder combination is present, the value of the case input variable FAR is the fineness ratio of the cylinder preceding the frustum closest to the nose. If the first frustum follows variations I, II, or III, then the input value of FAR is given by

$$\text{FAR} = \frac{\text{Length of larger diameter cylinder} + \text{Length of smaller diameter cylinder}}{\text{Diameter of larger diameter cylinder}}$$

- (9) For variations I, II, and III, the vehicle cannot have a third cylinder immediately following the smaller diameter cylinder. This cylinder can be followed only by a boat-tail, frustum, or frustum-cylinder combination for variations I and II and only by a boattail for variation III.
- (10) For variation V a variation III is allowed only after the last frustum-cylinder combination.
- (11) For variation IV, the value of the case input variable THNR must be 0.0.
- (12) The units of the input station coordinates and diameters are optional but should be self-consistent. The units of the input angles must be degrees.
- (13) The value of the case input variable FNR must be the fineness ratio of the sharp tangent ogive. If the ogive is blunted, then the length of the sharp ogive can be determined by

$$L = \sqrt{2Rr - r^2}$$

and the value of FNR is L/D_0 .

Considerations Which Should Be Given to Case Input

It is desirable to input the stations for each component at approximately every $0.2D_0$ for $0 \leq x/D_0 \leq 1.0$, at every $0.25D_0$ for $1.0 < x/D_0 \leq 3.0$, and at every $0.5D_0$ for $3.0 < x/D_0$. Although this convention is not required, following it will generally yield an adequate description of the $D\lambda$ output.

Data for more than one vehicle may be input at a time simply by placing the data cards for the second vehicle immediately after the data cards for the first vehicle.

To obtain the $D\lambda$ distributions for a given vehicle over a range of Mach numbers, the outlined procedure should be followed.

(1) The first step is to see if the program can be used for the vehicle. Table I and figure 4 show the components and variations for which the program can be used; hence the user must determine whether the components which comprise the vehicle are included in this table or figure. If they are, then the program can be used. If, however, a vehicle has a component which is not included in table I or figure 4, then the program may be used to obtain $D\lambda$ distributions up to this component but not aft of it. A common example of this type vehicle is one in which a boattail occurs in the middle of the vehicle – component 8 is a boattail at the aft end of a vehicle. In this case the program can obtain $D\lambda$ distributions up to the boattail but not aft of it.

(2) The section "Restrictions on Case Input" should be reviewed.

(3) The case data must be properly coded and punched. This process is described in detail in the subsequent section "Case Input Data Cards Description."

(4) The case input data cards must be placed after the last fixed input data card.

(5) If $D\lambda$ values for more than one vehicle are desired, then the case input data for the second vehicle are placed immediately after the case data for the first vehicle.

(6) The fixed input data must be input into the program each time the program is run. If, however, $D\lambda$ values for more than one vehicle are desired, the fixed input data are input only once.

Case Input Data Cards Description

The case input data are input on punched cards and, for each vehicle, the case data cards consist of 8 single cards followed by three sets of cards where each set contains from 1 to 35 cards. The case data variables are defined in table II. The values of these variables are either integer numbers (numbers punched without a decimal) or decimal numbers (numbers punched with a decimal). Each integer number must be punched such that the last digit ends in a column which is a multiple of 5. The FORTRAN format used for the integer numbers is 14I5, and no more than 14 numbers may be punched on a card.

The decimal numbers must be punched according to the following restrictions.

(1) If the case input decimal number is a whole number, 27 for example, then this number may be punched either as 27. in which case the decimal point must end in a column which is a multiple of 7 or as 27.0 in which case the 0 must end in a column which is a multiple of 7.

(2) If the number is positive, then the sign does not have to be punched. If the number is negative, the sign must be punched.

(3) The number of values to the right of the decimal point may vary from 0 as in 27. to 6 as in .000001 but the total number of columns punched including the sign (if negative) and decimal point for a given number may not exceed 7. For example, the number -1580.12 cannot be punched as it is. It would have to be rounded off to -1580.1 in order to be punched.

(4) The FORTRAN format used for the decimal number is 10F7.3, and no more than 10 numbers may be punched on a card.

The examples of the case data given in the following description are applicable for example configuration I which is shown at the end of the Users' Section in figures 5 and 6 and table III.

First data card.- The first data card consists of a short heading which gives the name of the vehicle and any other information the user desires. The characters punched on this card are alphameric, and the first character is punched in column 2 and the last character cannot be punched beyond column 67. Spaces may be skipped between characters.

Example:

EXAMPLE CONFIGURATION 1

Second data card.- The second data card consists of the values of the case input variables NCMPS, NMACHN, NOXS, NDX, NC1, NC2, NC3, NFCYCM, NTHFRR, and NPUNCH. These values must be integers, and each value must end in a column which is a multiple of 5; that is, the value of NCMPS must end in column 5, the value of NMACHN must end in column 10, and so forth.

Example:

5 2 44 1 0 0 1 1 1 0

Third data card.- The third data card consists of the values of the case input variables THNR, THBR, FAR, and FNR. These values must be decimal numbers, and each value must end in a column which is a multiple of 7; that is, the value of THNR ends in column 7, the value of THBR ends in column 14, and so forth. Furthermore, there must be a value punched for each variable. If the vehicle does not have one of these variables, then the value of this variable must be punched as 0.0.

Example:

20.0 0.0 1.0 0.0

Fourth data card.- The fourth data card consists of the values of the case input variables XR4, XR5, XR7, DX4, DX5, DX7, and XR1C. These values are decimal numbers, and each value must end in a column which is a multiple of 7; that is, the value of XR4 must end in column 7, the value of XR5 must end in column 14, and so forth. A value must be punched for each variable. If one of these variables is not applicable for the vehicle, then its value must be punched as 0.0.

Example:

0.0 0.0 25.0 0.0 0.0 8.0 165.0

Fifth data card.- The fifth data card consists of the values of the case input variables THFRR(I). The number of values of this variable is equal to the value of the case input variable NTHFRR punched on the second data card. The values of THFRR(I) are decimal numbers, and each value must end in a column which is a multiple of 7; that is, the value of THFRR(1) must end in column 7, the value of THFRR(2) must end in 14, and so forth.

Example:

12.5

Sixth data card.- The sixth data card consists of the values of the case input variables DDRR(I). The number of values of this variable is equal to the value of the case input variable NFCYCM punched on the second data card. The values of DDRR(I) are decimal numbers, and each value must end in a column which is a multiple of 7; that is, the value of DDRR(1) must end in column 7, the value of DDRR(2) must end in column 14, and so forth.

Example:

.759

Seventh data card.- The seventh data card consists of the values of the case input variables COMPNO(I). The number of values of this variable is equal to the value of the case input variable NCMPS punched on the second data card. The values of COMPNO(I) are integers, and each value must end in a column which is a multiple of 5; that is, the value of COMPNO(1) must end in column 5, the value of COMPNO(2) must end in column 10, and so forth.

Example:

3 1 5 6 7

Eighth data card.- The eighth data card consists of the values of the case input variable NXS(I). The number of values of this variable is equal to the value of the case input variable NCMPS punched on the second data card. The sum of these values must equal the value of the case input variable NOXS punched on the second data card. The values of NXS(I) are integers, and each value must end in a column which is a multiple of 5; that is, the value of NXS(1) must end in column 5, the value of NXS(2) must end in column 10, and so forth.

Example:

3 5 8 7 21

First set of data cards following first eight single data cards.- This first set of data cards consists of the values of the case input variable DO(I). The number of values of this variable is equal to the value of the case input variable NCMPS punched on the second data card. The values of DO(I) are decimal numbers, and each value must end in a column which is a multiple of 7; that is, the value of DO(1) must end in column 7, the value of DO(2) must end in column 14, and so forth. If the value of NCMPS is larger than 10 then the value of DO(11) must end in column 7 of the next card, and so forth.

Example:

6.0 8.735 8.735 8.735 11.513

Second set of data cards following first eight single data cards.- This second set of data cards consists of the values of the case input variable MACHN(I). The number of values of this variable is equal to the value of the case input variable NMACHN punched on the second data card. The values of MACHN(I) are decimal numbers, and each value must end in a column which is a multiple of 7; that is, the value of MACHN(1) must end in column 7, the value of MACHN(2) must end in column 14, and so forth. If the value of NMACHN is larger than 10, then the value of MACHN(11) must end in column 7 of the next card, and so forth.

Example:

1.0 2.0

Last set of data cards.- This last set of data cards consists of the values of the case input variable XS(I). The number of values of this variable is equal to the value of the case input variable NOXS punched on the second data card. The values of XS(I) are decimal numbers, and each value must end in a column which is a multiple of 7; that is, the value of XS(1) must end in column 7, the value of XS(2) must end in column 14, and so forth. If the value of NOXS is larger than 10 (which is almost always the case), then the value of XS(11) must end in column 7 of the next card, and so forth.

Example:

175.0	174.0	173.0	173.0	171.0	169.0	167.0	165.0	165.0	164.0
163.0	162.0	161.0	160.0	158.0	156.265	156.265	155.0	154.0	153.0
152.0	151.0	150.0	150.0	148.0	146.0	144.0	142.0	140.0	138.0
136.0	134.0	130.0	125.0	120.0	115.0	110.0	100.0	75.0	50.0
25.0	15.0	5.0	-5.0						

OUTPUT

The output begins with a listing of the input parameters and code numbers, and, for each Mach number, the stations and load characteristics ($D\lambda$ values) follow. For ogive-cylinder, sphere-cone, and sphere-ogive combinations, the $D\lambda$ values are continuous at the junction points and only one value is printed at the junction points. For each of the other combinations, the $D\lambda$ values are discontinuous at the junction points and two values are printed at each junction point.

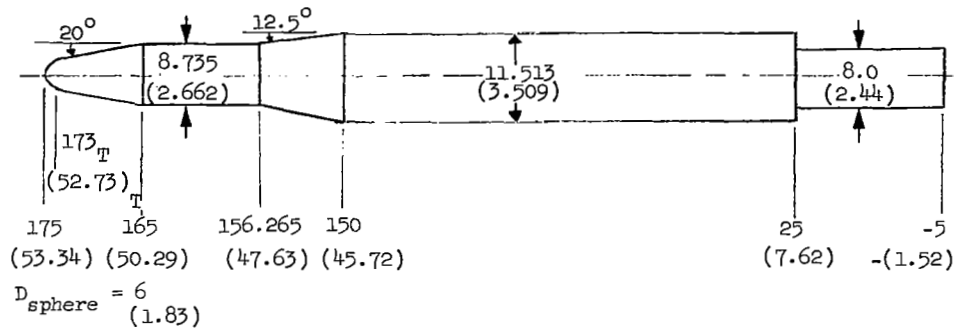
For components 4 and 8 no fixed input data in the subsonic and transonic range are input to the program. For any case input Mach number which is less than or equal to 1.35, the message NO FIXED INPUT DATA FOR CYLINDER FOLLOWING OGIVE IN SUBSONIC AND TRANSONIC RANGE ARE INPUT TO PROGRAM or NO FIXED INPUT DATA FOR BOATTAIL FOLLOWING LONG CYLINDER IN SUBSONIC AND TRANSONIC RANGE ARE INPUT TO PROGRAM is printed.

For component 6 several estimated curves are used in the fixed input data. If these estimated curves play a major role in determining $D\lambda$ values for the vehicle, then the message THE DLAMBDA VALUES FOR THE FRUSTUM ARE ESTIMATED FOR THIS MACH NUMBER is printed. The various checks which the program performs on these estimated curves are described in detail in the section "Program Logic" found in the Programers' Section of this report.

If a vehicle has a geometric parameter, or if a Mach number for which $D\lambda$ values are desired does not lie within the ranges given in table I, then errors may be introduced as a result of the extrapolation, and the results should be reviewed.

If punched card output is obtained, the cards are punched exactly as the μ coordinates and $D\lambda$ values are printed. The value of the μ coordinate will end in column 16, and the $D\lambda$ value will end in column 32. The format for the punched cards is 2E16.8.

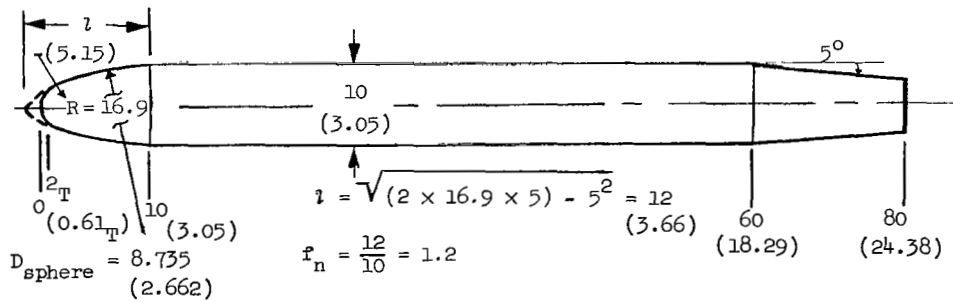
Two example configurations are shown in figure 5, and the computer printout for these examples is shown in table III. The printout is shown in graphical form for each example in figure 6.



$$f_a = \frac{165 - 156.265}{8.735} = 1.0$$

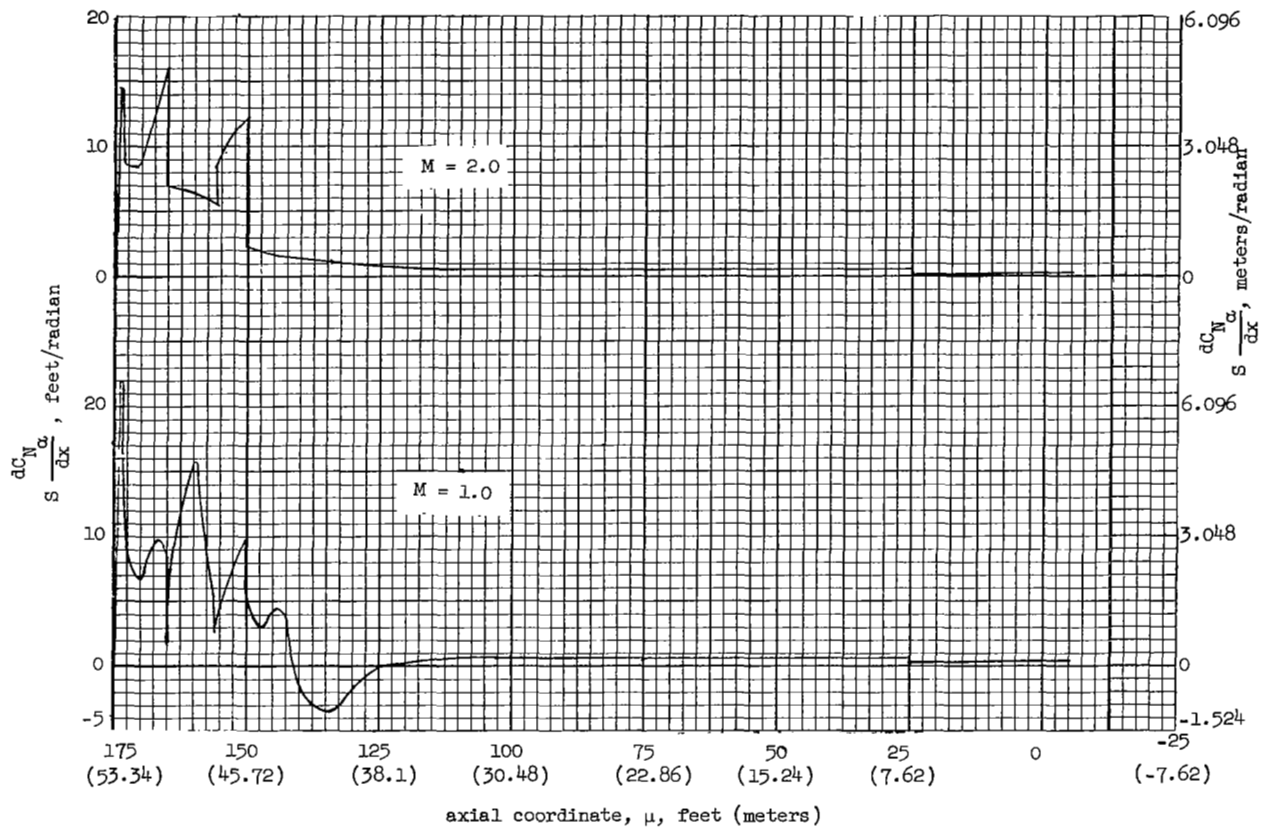
$$\left(\frac{D_1}{D_0}\right)_1 = \frac{8.735}{11.513} = .759$$

(a) Example configuration 1.



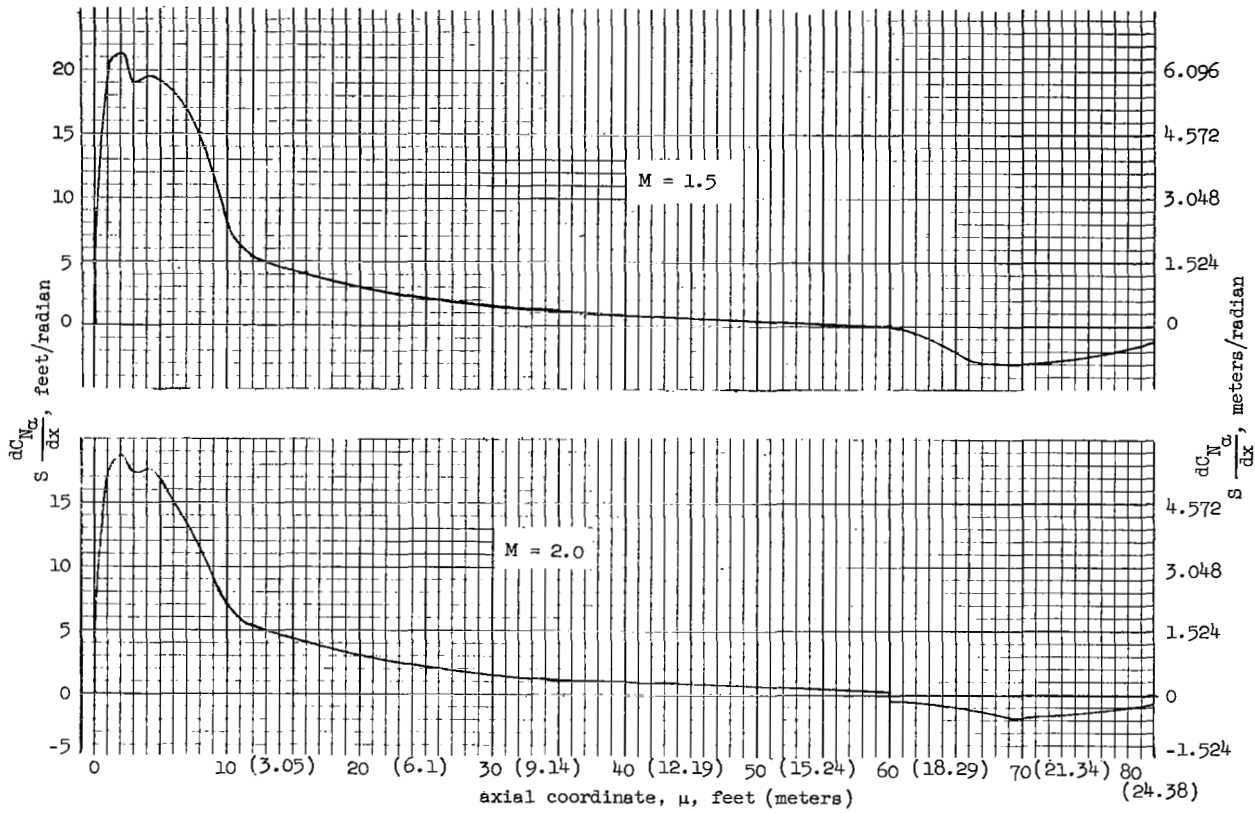
(b) Example configuration 2.

Figure 5.- Two example configurations. All stations and diameters are in feet (meters).



(a) Example configuration 1.

Figure 6.- Load characteristics for typical launch-vehicle configurations.



(b) Example configuration 2.

Figure 6.- Concluded.

TABLE III.- COMPUTER OUTPUT FOR EXAMPLE CONFIGURATIONS 1 AND 2

EXAMPLE CONFIGURATION 1

INPUT PARAMETERS

NCMPS=5 NMACHN=2 NOXS=44 NDX=1 NC1=0 NC2=0 NC3=1 NFCYCM=1 NTHFRR=1 NPUNCH=0
 THNR=20.0 THBR=0. FAR=1. FNR=0.
 XR4=0. XR5=0. XR7=25. DX4=0. DX5=0. DX7=8. XRLC=165.

THFRR(I)
 12.500

DDRR(I)
 .759

COMPNO(I)	D0(I)	NXS(I)
3	6.000	3
1	8.735	5
5	8.735	8
6	8.735	7
7	11.513	21

MACH= 1.000

STATION	DLAMBDA
1.75000000E+02	0.
1.74000000E+02	2.20497778E+01
1.73000000E+02	1.11063566E+01
1.71000000E+02	6.77071547E+00
1.69000000E+02	8.75503113E+00
1.67000000E+02	9.93587196E+00
1.65000000E+02	8.21090000E+00
1.65000000E+02	1.74700000E+00
1.64000000E+02	7.39400000E+00
1.63000000E+02	1.10916000E+01
1.62000000E+02	1.38500500E+01
1.61000000E+02	1.56452500E+01
1.60000000E+02	1.59067500E+01
1.58000000E+02	1.04436000E+01
1.56265000E+02	5.15365000E+00
1.56265000E+02	2.44580000E+00
1.55000000E+02	4.52116963E+00
1.54000000E+02	5.95017724E+00
1.53000000E+02	7.12443412E+00
1.52000000E+02	8.14288313E+00
1.51000000E+02	9.14230789E+00
1.50000000E+02	9.95874857E+00
1.50000000E+02	6.65323468E+00
1.48000000E+02	3.04494097E+00
1.46000000E+02	4.78672870E+00

TABLE III.- COMPUTER OUTPUT FOR EXAMPLE CONFIGURATIONS 1 AND 2 - Continued

1.44000000E+02	4.51005265E+00
1.42000000E+02	8.14148950E-01
1.40000000E+02	-1.64169983E+00
1.38000000E+02	-3.01453605E+00
1.36000000E+02	-3.51333088E+00
1.34000000E+02	-3.32138757E+00
1.30000000E+02	-1.66516955E+00
1.25000000E+02	2.29477250E-02
1.20000000E+02	3.06695442E-01
1.15000000E+02	5.29463792E-01
1.10000000E+02	7.70463792E-01
1.00000000E+02	8.22357117E-01
7.50000000E+01	7.61584950E-01
5.00000000E+01	7.61584950E-01
2.50000000E+01	7.61584950E-01
2.50000000E+01	5.29200000E-01
1.50000000E+01	5.29200000E-01
5.00000000E+00	5.29200000E-01
-5.00000000E+00	5.29200000E-01

MACH= 2.000

STATION	DLAMBDA
1.75000000E+02	0.
1.74000000E+02	1.44963333E+01
1.73000000E+02	8.61413048E+00
1.71000000E+02	8.38696873E+00
1.69000000E+02	1.11041449E+01
1.67000000E+02	1.38914817E+01
1.65000000E+02	1.61597500E+01
1.65000000E+02	6.98800000E+00
1.64000000E+02	6.98800000E+00
1.63000000E+02	6.96270000E+00
1.62000000E+02	6.90065000E+00
1.61000000E+02	6.79945000E+00
1.60000000E+02	6.53620000E+00
1.58000000E+02	5.93500000E+00
1.56265000E+02	5.24100000E+00
1.56265000E+02	8.38431544E+00
1.55000000E+02	9.14661877E+00
1.54000000E+02	9.73594406E+00
1.53000000E+02	1.03076740E+01
1.52000000E+02	1.09007133E+01
1.51000000E+02	1.15083991E+01
1.50000000E+02	1.21062634E+01
1.50000000E+02	2.38191046E+00
1.48000000E+02	2.16431528E+00

TABLE III.- COMPUTER OUTPUT FOR EXAMPLE CONFIGURATIONS 1 AND 2 - Continued

1.46000000E+02	1.98250747E+00
1.44000000E+02	1.77213652E+00
1.42000000E+02	1.66351143E+00
1.40000000E+02	1.53182462E+00
1.38000000E+02	1.43029183E+00
1.36000000E+02	1.32372837E+00
1.34000000E+02	1.23023343E+00
1.30000000E+02	1.08457187E+00
1.25000000E+02	9.46492291E-01
1.20000000E+02	8.73043688E-01
1.15000000E+02	7.42800854E-01
1.10000000E+02	6.65644928E-01
1.00000000E+02	5.64452710E-01
7.50000000E+01	4.60654867E-01
5.00000000E+01	4.60654867E-01
2.50000000E+01	4.60654867E-01
2.50000000E+01	3.20093714E-01
1.50000000E+01	3.20093714E-01
5.00000000E+00	3.20093714E-01
-5.00000000E+00	3.20093714E-01

TABLE III.- COMPUTER OUTPUT FOR EXAMPLE CONFIGURATIONS 1 AND 2 - Continued

EXAMPLE CONFIGURATION 2

INPUT PARAMETERS

NCMPS=4 NMACHN=2 NOXS=29 NDX=0 NC1=0 NC2=0 NC3=0 NFCYCM=1 NTHFRR=1 NPUNCH=0
 THNR=0. THBR=5. FAR=0. FNR=1.2
 XR4=0. XR5=0. XR7=0. DX4=0. DX5=0. DX7=0. XR1C=10.

 THFRR(I)

 0.

 DDDR(I)

 0.

COMPNO(I)	D0(I)	NXS(I)
3	8.735	3
2	10.000	6
4	10.000	12
8	10.000	8

MACH= 1.500

STATION	DLAMBDA
0.	0.
1.00000000E+00	2.04935586E+01
2.00000000E+00	2.11421467E+01
3.00000000E+00	1.90481776E+01
4.00000000E+00	1.98268914E+01
6.00000000E+00	1.84077951E+01
8.00000000E+00	1.49709627E+01
1.00000000E+01	8.14736272E+00
1.20000000E+01	5.51026129E+00
1.40000000E+01	4.83253871E+00
1.60000000E+01	4.20887419E+00
1.80000000E+01	3.63926774E+00
2.00000000E+01	3.06966129E+00
2.50000000E+01	2.21375806E+00
3.00000000E+01	1.60112903E+00
3.50000000E+01	1.31708065E+00
4.00000000E+01	7.68080645E-01
5.00000000E+01	2.50500000E-01
6.00000000E+01	3.63709677E-02
6.00000000E+01	-7.50000000E-02
6.20000000E+01	-6.00719453E-01
6.40000000E+01	-1.39503351E+00
6.60000000E+01	-2.39868981E+00
6.80000000E+01	-2.95210336E+00
7.00000000E+01	-3.17646502E+00
7.50000000E+01	-2.06523457E+00
8.00000000E+01	-1.34898178E+00

TABLE III.- COMPUTER OUTPUT FOR EXAMPLE CONFIGURATIONS 1 AND 2 - Concluded

MACH= 2.000

STATION	DLAMBDA
0.	0.
1.00000000E+00	1.78156951E+01
2.00000000E+00	1.88320817E+01
3.00000000E+00	1.74064891E+01
4.00000000E+00	1.76526230E+01
6.00000000E+00	1.48578013E+01
8.00000000E+00	1.14253912E+01
1.00000000E+01	6.55813882E+00
1.20000000E+01	5.27437419E+00
1.40000000E+01	4.66842581E+00
1.60000000E+01	4.10911613E+00
1.80000000E+01	3.59644516E+00
2.00000000E+01	3.08377419E+00
2.50000000E+01	2.27383871E+00
3.00000000E+01	1.68741935E+00
3.50000000E+01	1.38038710E+00
4.00000000E+01	8.81387097E-01
5.00000000E+01	3.88000000E-01
6.00000000E+01	1.62580645E-01
6.00000000E+01	-3.00000000E-01
6.20000000E+01	-6.92395514E-01
6.40000000E+01	-1.06952569E+00
6.60000000E+01	-1.38506436E+00
6.80000000E+01	-1.67063679E+00
7.00000000E+01	-1.92444277E+00
7.50000000E+01	-1.43828836E+00
8.00000000E+01	-7.96386833E-01

PROGRAMERS' SECTION

PROGRAM LOGIC

In referring to reference 1, note that the fixed input data are values of $\frac{1}{D} S \frac{dC_{N\alpha}}{dx} (= \lambda)$. Hence, after the interpolations on λ are performed, the program multiplies the results by D to obtain the final form $S \frac{dC_{N\alpha}}{dx} (= D\lambda)$. This process is applied to every case input x station for each component comprising the vehicle.

For best results the program should be used for vehicles which have geometric parameters within the ranges given in table I, and the case input Mach numbers should, if possible, also be within the ranges given in table I. If certain parameters or Mach numbers are outside these ranges, then the program may still be used to obtain $D\lambda$ distributions with the understanding that sizable errors may be introduced as a result of the extrapolation. In order to decrease the size of these errors, λ values for limiting

values of certain parameters have been incorporated as a part of the program. These λ values in general do not represent experimental results, and anytime these values are used in an interpolation, the final results should be reviewed as to their reliability. The geometric significance of the limiting parameter values are shown in figure 7. The description of the λ values which correspond to the limiting parameter values are given in table IV. Some of the limiting parameters and associated λ values are inputs to the program and some are calculated in the program.

In obtaining the λ values for an ogive with $f_n = 0.5$ one can use with some modification the equation for the λ values for a sphere given by equation (1). The value of A can be obtained for the desired Mach number by interpolating the proper A values

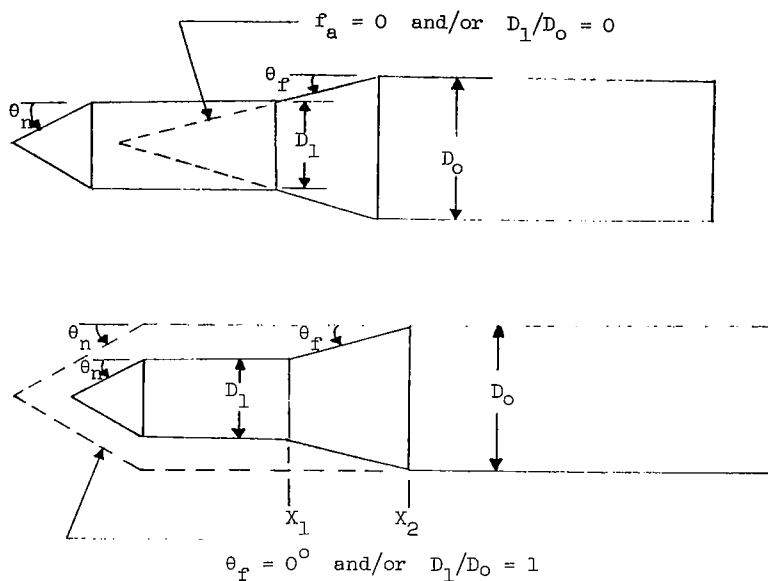


Figure 7.- Geometric significance of parameter limitations for components 6 and 7.

TABLE IV.- PARAMETER LIMITATIONS AND λ VALUES USED FOR THESE LIMITATIONS

Component	Parameter limitation	λ values used for the limitations
1	$\theta_n = 0^\circ$	λ is taken to be a small number, usually 0.01 or 0.001 for each x/L station and Mach number*
2	$f_n = 0.5$	When $f_n = 0.5$, the ogive becomes a sphere; hence the λ values were obtained from sphere values*
3	None required	
4	$f_n = 0.5$	No fixed input data in program for cylinder following sphere
5	$\theta_n = 0^\circ$	$\lambda = 0.01$ for all x/L stations and Mach numbers except Mach 15 in which case $\lambda = 0.116$ for all x/L stations*
6	$\theta_f = 0^\circ$	λ values are obtained from the λ values for a cylinder following a cone beginning at station X1 as shown in figure 7 [†]
	$f_a = 0$	λ values are obtained from λ values for a cone*
7	$D_1/D_0 = 0$	λ values are obtained from λ values for a cylinder following a cone [†]
	$D_1/D_0 = 1$ or $\theta_f = 0^\circ$	λ values are obtained from a cylinder following a cone beginning at station X2 as shown in figure 7 [†]
8	$\theta_b = 0^\circ$	$\lambda = 0.0$ for all x/D_0 stations and Mach numbers*

*These λ values are input to the program.

[†]These λ values are calculated in the program.

given in the fixed data listing for sphere data. The modified equation is

$$\lambda_{f_n=.5} = 2\pi A \left(1 - \frac{x}{L}\right) \sqrt{.5 \frac{x}{L} \left(1 - .5 \frac{x}{L}\right)}$$

where x/L assumes the values given in the fixed data listing for sharp tangent ogives.

The λ values for hypersonic Mach numbers were calculated by means of the modified Newtonian theory as presented in reference 3. These values are input to the program as Mach 15 data and serve as an upper boundary on Mach number. For any case input Mach number greater than or equal to 15, the program will use these values and no interpolation on Mach number will be performed.

The program can accommodate five variations from the list of eight basic components shown in table I. These variations and associated parameters are shown in figure 4. In obtaining the $D\lambda$ distributions for variations I, II, and III; the program considers each variation as being a single cylinder, calculates the λ values for this cylinder – it should be recalled that the λ values are independent of body diameter – and multiplies these values by the appropriate diameter. The $D\lambda$ results obtained for variation IV are valid only when $f_a \geq 4.0$. Again the λ values associated with these variations do not represent experimental data, and the $D\lambda$ distributions obtained for any of these variations should be reviewed.

A simplified flow chart for the program is shown in figure 8. Detailed flow charts for the individual components are shown in figures 9 to 11.

The process which the program uses to obtain the $D\lambda$ distributions for components 1, 6, and 7 is shown in figures 9 to 11, respectively. In general the process consists of linearly interpolating the proper fixed input data values. If no interpolation is required at some of the case input parameters, then the program will omit some of the steps shown in figures 9 to 11. If insufficient fixed input data is present to permit an interpolation, then the program will extrapolate.

The λ values for components 2, 4, 5 and 8 are functions of three parameters – Mach number, x/D_0 (x/L for component 2), and the appropriate other parameter (f_n for components 2 and 4, θ_n for component 5, and θ_b for component 8). Consequently, the steps used to obtain the $D\lambda$ distributions for each of these components are similar to those used for component 1.

The $D\lambda$ values for component 3 are obtained by use of the following closed-form equation:

$$D\lambda = 8\pi D_0 A \left(0.5 - \frac{x}{D_0}\right) \left(1 - \frac{x}{D_0}\right) \left(\frac{x}{D_0}\right) \quad (1)$$

which is derived from equation (A16) of reference 1. For a given case input Mach number, the program will interpolate on the fixed input A values to find a value to use in equation (1), will convert the case input x stations into x/D_0 values, and will substitute these values into equation (1).

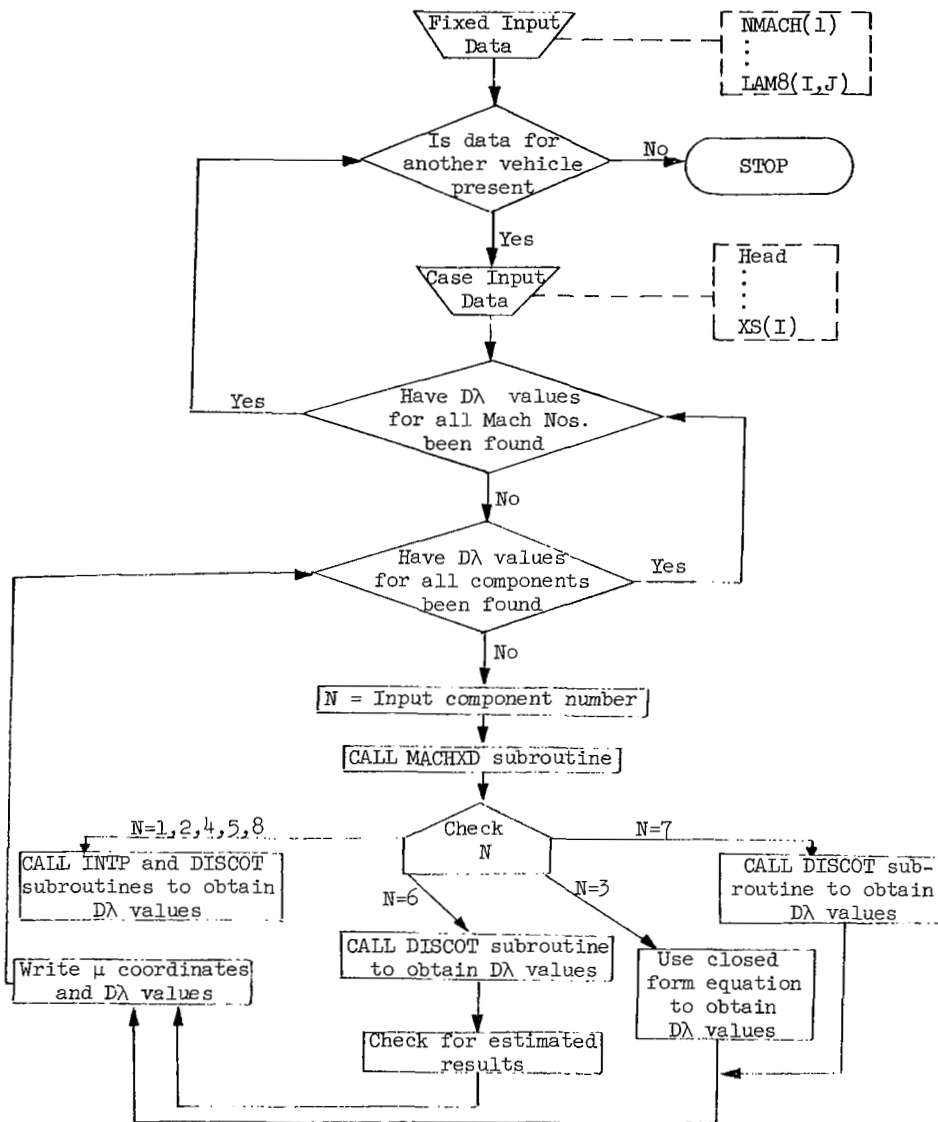


Figure 8.- Program flow chart.

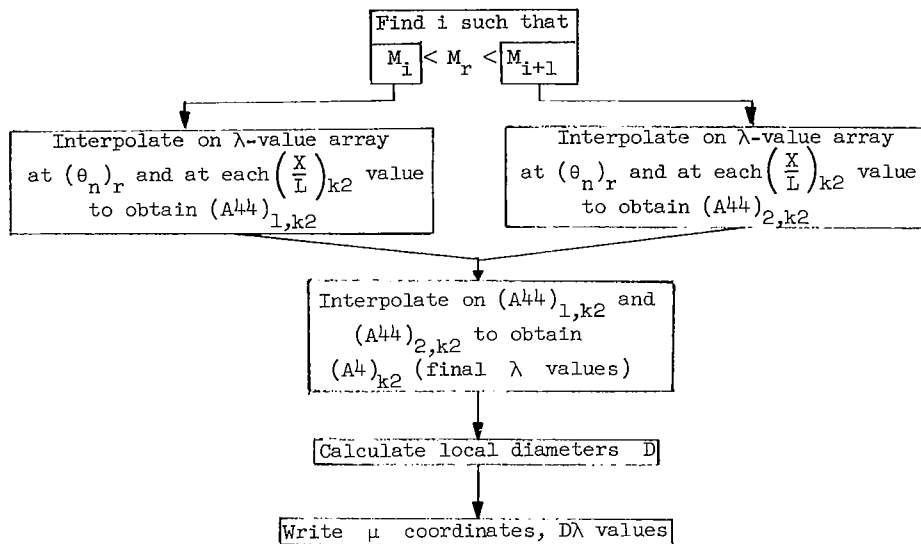


Figure 9.- Flow chart for component 1.

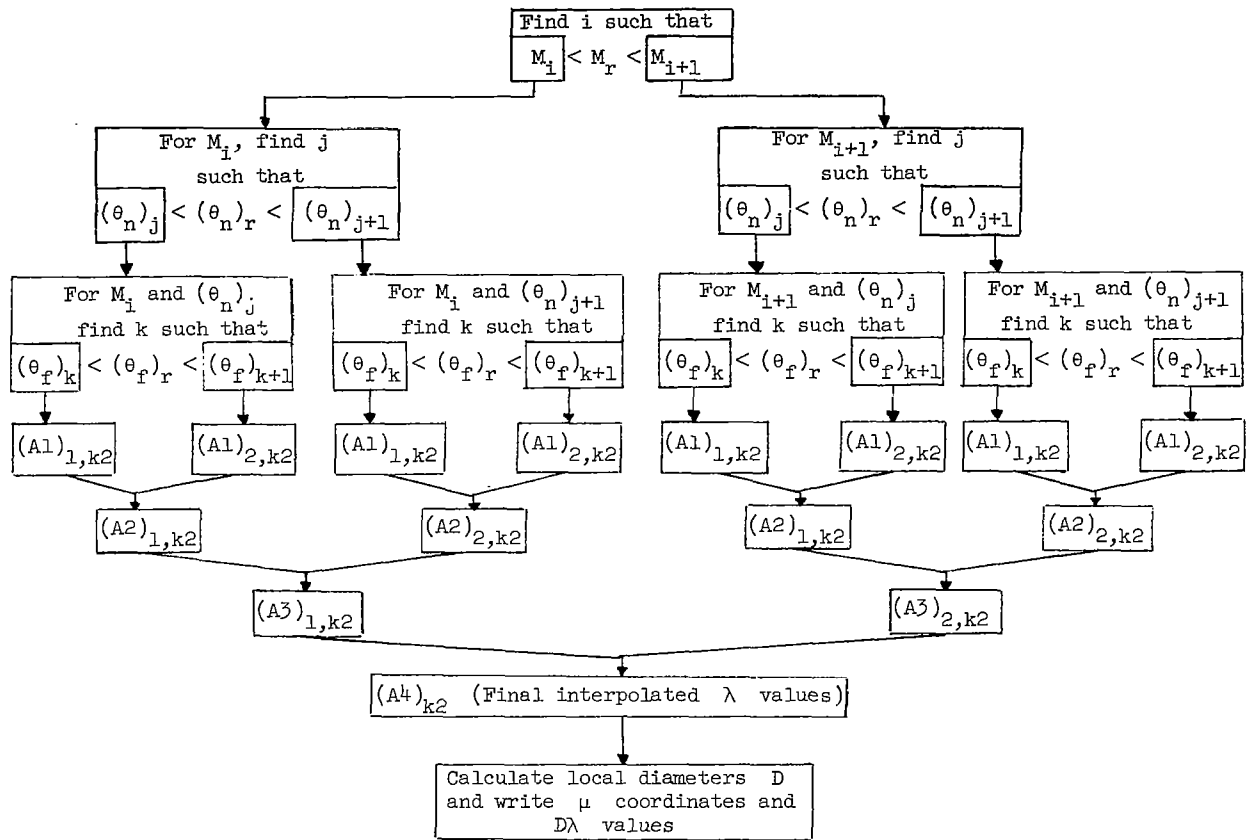


Figure 10.- Flow chart for component 6.

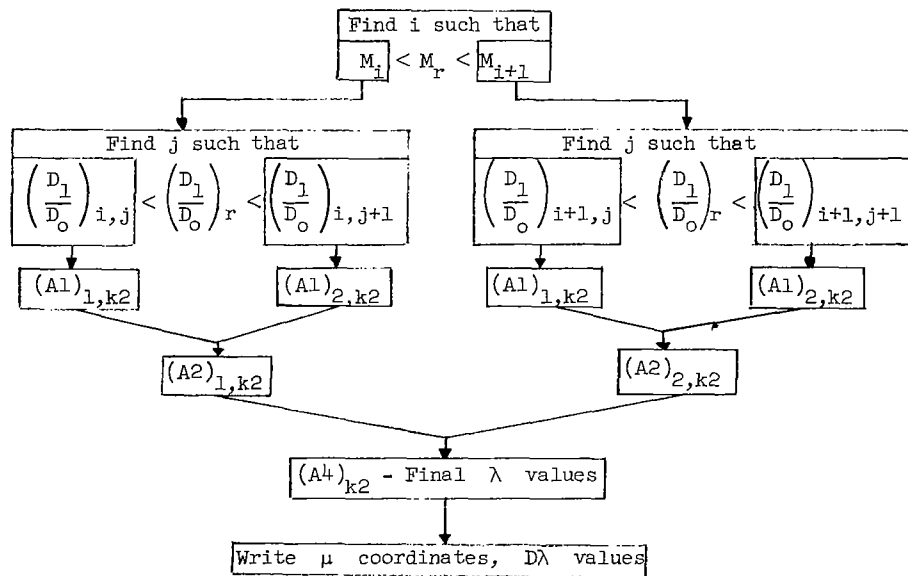


Figure 11.- Flow chart for component 7.

COMPUTER PROGRAM

The computer program consists of a main program, three main subroutines, and the fixed input data. The name and purpose of each subroutine is described as follows:

<u>Subroutine</u>	<u>Purpose</u>
MACHXD	Converts case input μ coordinates into x/D_0 or x/L stations, determines if interpolation at case input Mach number is required and if so finds two fixed input Mach numbers to use in interpolation
INTP	Determines $D\lambda$ values for components 1, 2, 4, 5, and 8
DISCOT	Performs all interpolations for all components; sometimes this subroutine is used to perform simultaneous double interpolations at two independent variables, and sometimes it is used to interpolate at only one independent variable

The DISCOT subroutine includes three subroutines, UNS, DISSER, and LAGRAN, which are never called for in the main program but are an inherent part of the DISCOT subroutine.

The purpose of the main program is to read in the fixed input data, read in the case input data, convert double or triple subscripted variables into single subscripted variables, and to obtain $D\lambda$ values for components 3, 6, and 7.

The programing is FORTRAN IV.

METHOD OF INPUTTING FIXED INPUT DATA

A complete listing of all the fixed input data which are input to the program is enclosed. These data include the following: (1) code numbers – these numbers, with one exception, tell the program "how many" parameter and λ values are being input. The exception is the set of code numbers which tell the program whether or not the frustum λ values are experimental or estimated; (2) the values of the parameters; and (3) the λ values.

The order in which these data appear in the data listing is the order in which they are input to the program, and this order must always be preserved. The cards which give the FORTRAN names of the variables are listed solely for that purpose and are not a part of the data. The definitions of these FORTRAN names can be found in table V.

The method of inputting the data is best described by considering each component separately.

TABLE V.- FORTRAN NAMES AND DEFINITIONS FOR FIXED INPUT DATA

FORTRAN name	Definition
FORTRAN names for fixed input data for component 1	
NMACH(1)	Number of Mach numbers
NXL1	Number of x/L values
NTHN1(I)	Number of θ_n values for Ith Mach number; I = 1 to NMACH(1)
NLAM1(I)	Number of λ values for Ith Mach number; I = 1 to NMACH(1)
MACH(1,I)	Values of the Mach numbers; I = 1 to NMACH(1)
XL1(J)	x/L values; J = 1 to NXL1
THN1(I,K)	θ_n values at the Ith Mach number; I = 1 to NMACH(1), K = 1 to NTHN1(I)
LAM1(I,L)	λ values at the Ith Mach number; I = 1 to NMACH(1), L = 1 to NLAM1(I)
FORTRAN names for fixed input data for component 2	
NMACH(2)	Number of Mach numbers
NXL2	Number of x/L values
NFN2(I)	Number of f_n values for Ith Mach number; I = 1 to NMACH(2)
NLAM2(I)	Number of λ values for Ith Mach number; I = 1 to NMACH(2)
MACH(2,I)	Values of the Mach numbers; I = 1 to NMACH(2)
XL2(J)	x/L values; J = 1 to NXL2
FN2(I,K)	f_n values at the Ith Mach number; I = 1 to NMACH(2), K = 1 to NFN2(I)
LAM2(I,L)	λ values at the Ith Mach number; I = 1 to NMACH(2), L = 1 to NLAM2(I)
FORTRAN names for fixed input data for component 3	
NMACH(3)	Number of Mach numbers
MACH(3,I)	Values of the Mach numbers; I = 1 to NMACH(3)
A(I)	A values; I = 1 to NMACH(3)
FORTRAN names for fixed input data for component 4	
NMACH(4)	Number of Mach numbers
NXD4	Number of x/D_0 values
NFN4(I)	Number of f_n values for Ith Mach number; I = 1 to NMACH(4)
NLAM4(I)	Number of λ values for Ith Mach number; I = 1 to NMACH(4)
MACH(4,I)	Values of the Mach numbers; I = 1 to NMACH(4)
XD4(J)	x/D_0 values; J = 1 to NXD4
FN4(I,K)	f_n values at Ith Mach number; I = 1 to NMACH(4), K = 1 to NFN4(I)
LAM4(I,L)	λ values at Ith Mach number; I = 1 to NMACH(4), L = 1 to NLAM4(I)

TABLE V.- FORTRAN NAMES AND DEFINITIONS FOR FIXED INPUT DATA -- Continued

FORTRAN name	Definition
FORTRAN names for fixed input data for component 5	
NMACH(5)	Number of Mach numbers
NXD5	Number of x/D_0 values
NTHN5(I)	Number of θ_n values for Ith Mach number; I = 1 to NMACH(5)
NLAM5(I)	Number of λ values for Ith Mach number; I = 1 to NMACH(5)
MACH(5,I)	Values of the Mach numbers; I = 1 to NMACH(5)
XD5(J)	x/D_0 values; J = 1 to NXD5
THN5(I,K)	θ_n values at Ith Mach number; I = 1 to NMACH(5), K = 1 to NTHN5(I)
LAM5(I,L)	λ values at Ith Mach number; I = 1 to NMACH(5), L = 1 to NLAM5(I)
FORTRAN names for fixed input data for component 6	
NMACH(6)	Number of Mach numbers
NXD6	Number of x/D_0 values
NTHN6(I)	Number of θ_n values for Ith Mach number; I = 1 to NMACH(6)
NTHF6(I,J)	Number of θ_f values at Ith Mach number and Jth θ_n ; I = 1 to NMACH(6), J = 1 to NTHN6(I)
NFA6(I,J,K)	Number of f_a values at Ith Mach number, Jth θ_n and Kth θ_f ; I = 1 to NMACH(6), J = 1 to NTHN6(I), K = 1 to NTHF6(I,J)
NLAM6(I,J,K)	Number of λ values at Ith Mach number, Jth θ_n and Kth θ_f ; I = 1 to NMACH(6), J = 1 to NTHN6(I), K = 1 to NTHF6(I,J)
NTOTL6(I,J)	Total number of λ values at Ith Mach number and Jth θ_n ; I = 1 to NMACH(6), J = 1 to NTHN6(I)
NTOTFA(I,J)	Total number of f_a values at Ith Mach number and Jth θ_n ; I = 1 to NMACH(6), J = 1 to NTHN6(I)
MACH(6,I)	Values of the Mach numbers; I = 1 to NMACH(6)
XD6(L)	x/D_0 values; L = 1 to NXD6
THN6(I,J)	θ_n values at Ith Mach number; I = 1 to NMACH(6), J = 1 to NTHN6(I)
THF6(I,J,K)	θ_f values at Ith Mach number and Jth θ_n ; I = 1 to NMACH(6), J = 1 to NTHN6(I), K = 1 to NTHF6(I,J)
FA6(I,J,M)	f_a values at Ith Mach number and Jth θ_n ; I = 1 to NMACH(6), J = 1 to NTHN6(I), M = 1 to NTOTFA(I,J)
K1(I,J,M)	Code numbers denoting experimental or estimated data at Ith Mach number and Jth θ_n ; I = 1 to NMACH(6), J = 1 to NTHN6(I), M = 1 to NTOTFA(I,J)
LAM6(I,J,N)	λ values at Ith Mach number and Jth θ_n ; I = 1 to NMACH(6), J = 1 to NTHN6(I), N = 1 to NTOTL6(I,J)

TABLE V.- FORTRAN NAMES AND DEFINITIONS FOR FIXED INPUT DATA – Concluded

FORTRAN name	Definition
FORTRAN names for fixed input data for component 7	
NMACH(7)	Number of Mach numbers
NXD7	Number of x/D_0 values
NDDR7(I)	Number of D_1/D_0 values for Ith Mach number; I = 1 to NMACH(7)
NTHF7(I,J)	Number of θ_f values for Ith Mach number and Jth D_1/D_0 ; I = 1 to NMACH(7), J = 1 to NDDR7(I)
NLAM7(I,J)	Number of λ values at Ith Mach and Jth D_1/D_0 ; I = 1 to NMACH(7), J = 1 to NDDR7(I)
MACH(7,I)	Values of the Mach numbers; I = 1 to NMACH(7)
XD7(K)	x/D_0 values; K = 1 to NXD7
DDR7(I,J)	D_1/D_0 values at Ith Mach number; I = 1 to NMACH(7), J = 1 to NDDR7(I)
THF7(I,J,L)	θ_f values at Ith Mach number and Jth D_1/D_0 ; I = 1 to NMACH(7), J = 1 to NDDR7(I), L = 1 to NTHF7(I,J)
LAM7(I,J,M)	λ values at Ith Mach number and Jth D_1/D_0 ; I = 1 to NMACH(7), J = 1 to NDDR7(I), M = 1 to NLAM7(I,J)
FORTRAN names for fixed input data for component 8	
NMACH(8)	Number of Mach numbers
NXD8	Number of x/D_0 values
NTHB8(I)	Number of θ_b values at Ith Mach number; I = 1 to NMACH(8)
NLAM8(I)	Number of λ values at Ith Mach number; I = 1 to NMACH(8)
MACH(8,I)	Values of the Mach numbers; I = 1 to NMACH(8)
XD8(J)	x/D_0 values; J = 1 to NXD8
THB8(I,K)	θ_b values at Ith Mach number; I = 1 to NMACH(8), K = 1 to NTHB8(I)
LAM8(I,L)	λ values at Ith Mach number; I = 1 to NMACH(8), L = 1 to NLAM8(I)

Component 1

Corresponding to each Mach number, there is associated a λ value array which is a function of the θ_n values for which data are available for this Mach number and also a function of a fixed set of x/L values. These λ values are input columnwise as denoted by the arrows in table VI. The complete set of λ values for all Mach numbers are input as a two-dimensional array where the first subscript refers to Mach number, and the second refers to the position in the associated λ value array.

The fixed set of x/L values, the Mach numbers, and the corresponding sets of θ_n values are all input in ascending order.

An example of the λ value array form for a given Mach number is included in table VI. (Table VI is found at the end of the Programers' Section.)

Components 2, 4, 5, and 8

The method of inputting the storage data for each of these components is similar to the method used for component 1. An example of the λ value array form for a given Mach number for each of these components is included in table VI.

Component 3

The $D\lambda$ values for this component are determined by the closed-form equation (eq. (1)); hence, no λ values are input. The only parameters input are Mach number and corresponding coefficients $A(I)$. The Mach numbers are input in ascending order.

Component 6

Corresponding to each Mach number, θ_n , and θ_f combination, there is associated a λ value array which is a function of the f_a values for which data are available for the given Mach number, θ_n , and θ_f combination and also a function of a fixed set of x/D_0 values. Hence, for a given Mach number and θ_n combination, there exists as many λ value arrays as there are θ_f values which correspond to the Mach number and θ_n value. These individual arrays are combined into a single array, which now – for a given Mach number and θ_n value – is a function of f_a , θ_f , and x/D_0 . These λ values are input columnwise as denoted by the arrows in table VI. The complete set of λ values for all Mach numbers and θ_n values are input as three-dimensional variables where the first subscript refers to Mach number, the second refers to the θ_n value, and the third refers to the position in the associated λ value array.

The Mach numbers and corresponding sets of θ_n values are input in ascending order. The sets of θ_f values which correspond to each Mach number and θ_n combination are also input in ascending order. The sets of f_a values which correspond to each Mach number, θ_n , and θ_f combination are input in ascending order. The fixed set of x/D_0 values are input in ascending order.

If for a given Mach number, θ_n , θ_f , and f_a combination; the associated λ value curve is estimated, then the value of the fixed input variable $K1$ is 0. If the associated λ value curve is experimental, then the value of $K1$ is 1.

An example of the array form for a given Mach number and θ_n value is included in table VI.

Component 7

Corresponding to each Mach number and D_1/D_0 combination, there exists an array of λ values which is a function of the θ_f values for which data are available for this Mach number and D_1/D_0 combination and also a function of a fixed set of x/D_0

values. These λ values are input columnwise as denoted by the arrows in table VI. The complete set of λ values for all Mach numbers and D_1/D_0 combinations are input as three-dimensional variables where the first subscript refers to Mach number, the second refers to the D_1/D_0 value, and the third refers to the position in the associated λ value array.

The fixed set of x/D_0 values, the Mach numbers, and the corresponding sets of D_1/D_0 values are all input in ascending order. The θ_f values which correspond to each Mach number and D_1/D_0 combination are also input in ascending order.

An example of the array form for a given Mach number and D_1/D_0 combination is included in table VI.

TABLE VI.- EXAMPLE OF FORM OF λ -VALUE ARRAY FOR INPUTTING FIXED
INPUT DATA FOR EACH COMPONENT

Component	Example of form of λ -value array				
1	Mach(1,1) = .7				
	XL1(J)				
	THN(1,K)	0.0	.2	.4 .6 .8	1.0
	0	LAM1(1,1) = .00	LAM1(1,7) = .01		LAM1(1,31) = .01
	10	LAM1(1,2) = .00			
	15	↓	↓		↓
	40	LAM1(1,6) = .00			LAM1(1,36) = .35
2	Mach(2,1) = .8				
	XL2(J)				
	FN2(1,K)	0.0	.05	.10 - -	1.00
	.50	LAM2(1,1) = 0.00	LAM2(1,5) = 2.58		LAM2(1,81) = 0.00
	1.39	LAM2(1,2) = 4.15			↓
	3.00	LAM2(1,3) = 1.95	↓		↓
	6.00	LAM2(1,4) = 1.25			LAM2(1,84) = 0.01
The complete set of XL2(J) for each array for this component is .00, .05, .10, .15, .20, .25, .30, .35, .40, .45, .50, .55, .60, .65, .70, .75, .80, .85, .90, .95, 1.00.					
4	Mach(4,1) = 3.0				
	XD4(J)				
	FN4(1,K)	0.0	.5	1.0 - -	6.5
	3	LAM4(1,1) = .405	LAM4(1,4) = .320		LAM4(1,40) = .025
	5	LAM4(1,2) = .270	↓		↓
	7	LAM4(1,3) = .178			LAM4(1,42) = .013
	The complete set of XD4(J) for each array for this component is 0.0, .5, 1.0, 1.5, 2.0, 2.5, 3.0, 3.5, 4.0, 4.5, 5.0, 5.5, 6.0, 6.5.				
5	Mach(5,2) = .8				
	XD5(J)				
	THN5(2,K)	0.0	.1	- - -	6.5
	0	LAM5(2,1) = .01	LAM5(2,8) = .01		LAM5(2,162) = .01
	10	LAM5(2,2) = .63	↓		↓
	15	↓	↓		↓
	40	LAM5(2,7) = -2.47			LAM5(2,168) = .03
The complete set of XD5(J) for each array for this component is .0, .1, .2, .3, .4, .5, .6, .7, .8, .9, 1.0, 1.25, 1.5, 1.75, 2.0, 2.5, 3.0, 3.5, 4.0, 4.5, 5.0, 5.5, 6.0, 6.5.					

TABLE VI.- EXAMPLE OF FORM OF λ -VALUE ARRAY FOR INPUTTING FIXED
INPUT DATA FOR EACH COMPONENT - Concluded

Component	Example of form of λ -value array				
6	Mach(6,7) = 4.04, THN6(7,1) = 15 ⁰ , THF6(7,1,1) = 5 ⁰				
	XD6(L) FA6(7,1,M)	0.0	0.2	0.4 - -	6.5
	0	LAM6(7,1,1) = .52	LAM6(7,1,4) = .52		LAM6(7,1,52) = .52
	1	LAM6(7,1,2) = .74	↓		↓
	4	LAM6(7,1,3) = .30	↓		LAM6(7,1,54) = .45
			THF6(7,1,2) = 20 ⁰		
	1	LAM6(7,1,55) = 2.05	LAM6(7,1,57) = 1.90		LAM6(7,1,89) = 2.30
	4	LAM6(7,1,56) = 1.80	↓		LAM6(7,1,90) = 1.90
	The complete set of XD6(L) for each array for this component is 0.0, 0.2, 0.4, 0.6, 0.8, 1.0, 1.25, 1.5, 2.0, 2.5, 3.0, 3.5, 4.0, 4.5, 5.0, 5.5, 6.0, 6.5.				
	7	Mach(7,1) = .80, DDR7(1,1) = .70			
XD7(K) THF7(1,1,L)		0.0	0.1	0.2 - -	6.5
5		LAM7(1,1,1) = -.370	LAM7(1,1,5) = .070		LAM7(1,1,93) = .06
10		LAM7(1,1,2) = -1.140	↓		↓
15		↓			↓
30		LAM7(1,1,4) = -1.500	↓		LAM7(1,1,96) = .095
The complete set of XD7(K) values for each array for this component is 0.0, .1, .2, .3, .4, .5, .6, .7, .8, .9, 1.0, 1.25, 1.5, 1.75, 2.0, 2.5, 3.0, 3.5, 4.0, 4.5, 5.0, 5.5, 6.0, 6.5.					
8	Mach(8,1) = 1.50				
	XD8(J) THB8(1,K)	0.0	0.1	.2 - -	2.5
	0	LAM8(1,1) = .000	LAM8(1,6) = .000		LAM8(1,56) = .000
	4	LAM8(1,2) = .000	↓		↓
	8	↓			↓
	16	LAM8(1,5) = -.060	↓		LAM8(1,60) = -.060
The complete set of XD8(J) values for each array for this component is 0.0, .1, .2, .4, .6, .8, 1.0, 1.25, 1.5, 1.75, 2.0, 2.5.					

CONCLUDING REMARKS

The results obtained from this program yield adequate characteristics for most launch-vehicle configurations at angles of attack less than 5° . Because of the lack of sufficient experimental data which are input to the program, certain discrepancies exist between experimental and empirical results. For components which have geometric parameters within the ranges of the fixed input data, these discrepancies are small. For components which have geometric parameters outside these ranges, the discrepancies may be larger, and the empirical results should be interpreted only as representing the trend of the characteristics curves.

Langley Research Center,
National Aeronautics and Space Administration,
Langley Station, Hampton, Va., August 21, 1967,
124-08-05-25-23.

APPENDIX A
PROGRAM LISTING

```

REAL MACH,MR,MR6,MR7,M1,LCN,MACHN,LAM1,LAM2,LAM4,LAM5,LAM6,
XLAM7,LAM8,LAM
  INTEGER COMPNO
  EXTERNAL DISCOT
  COMMON NMACH(8),NTHN1(14),NLAM1(14),MACH(8,16),THN1(14,17),XL1(6),
1LAM1(14,102),NLAM2(7),NFN2(7),XL2(21),FN2(7,5),LAM2(7,105),A(12),
2NLAM4(5),NFN4(5),XD4(14),FN4(5,3),LAM4(5,42),NLAM5(16),NTHN5(16),
3XD5(24),THN5(16,9),LAM5(16,216),NTHN6(8),NTHF6(8,3),
4NFA6(8,3,4),NLAM6(8,3,4),NTOTL6(8,3),NTOTFA(8,3),THN6(8,3),
5XD6(18),THF6(8,3,4),LAM6(8,3,288),FA6(8,3,16),K1(8,3,16),
6NDDR7(8),NTHF7(8,3),NLAM7(8,3),DDR7(8,3),THF7(8,3,4),LAM7(8,3,96),
7XD7(24),NTHB8(8),THB8(8,5),XD8(12),LAM8(8,60),NLAM8(8)
  COMMON HEAD(11),XX(100),X(25),LAM(225),NXS(14),XS(350),D0(14),
1A1(2,100),YA(17),TN(2),MACHN(15)
  COMMON A2(2,100),A3(2,100),M1(2),A11(2),A4(100),AA1(100),
1AN3(5),XX6(100),FA(4),K11(4),THF(4),A22(2),A33(2),XX7(100),AA2(2),
2D2(2),A12(2),COMPNO(14),A44(2,100),THFRR(5),DDRR(5)
C READ STATEMENTS FOR FIXED INPUT DATA FOR SHARP CONES
  READ(5,9502)NMACH(1)
  READ(5,9502)NXL1
  NM1=NMACH(1)
  READ(5,9502)(NTHN1(I),I=1,NM1)
  READ(5,9502)(NLAM1(I),I=1,NM1)
  READ(5,1600)(MACH(I,I),I=1,NM1)
  READ(5,1600)(XL1(J),J=1,NXL1)
  D01501I=1,NM1
  NTN=NTHN1(I)
1501 READ(5,1600)(THN1(I,K),K=1,NTN)
  D01502I=1,NM1
  NL=NLAM1(I)
1502 READ(5,1600)(LAM1(I,L),L=1,NL)
C READ STATEMENTS FOR FIXED INPUT DATA FOR SHARP TANGENT OGIVES
  READ(5,9502)NMACH(2)
  READ(5,9502)NXL2
  NM2=NMACH(2)
  READ(5,9502)(NFN2(I),I=1,NM2)
  READ(5,9502)(NLAM2(I),I=1,NM2)
  READ(5,1600)(MACH(2,I),I=1,NM2)
  READ(5,1600)(XL2(J),J=1,NXL2)

```

```

DO1503 I=1, NM2
NFN=NFN2(I)
1503 READ(5,1600)(FN2(I,K),K=1,NFN)
DO1504 I=1, NM2
NL=NLAM2(I)
1504 READ(5,1600)(LAM2(I,L),L=1,NL)
C READ STATEMENTS FOR FIXED INPUT DATA FOR SPHERES
READ(5,9502) NMACH(3)
NM3=NMACH(3)
READ(5,1600)(MACH(3,I),I=1,NM3)
READ(5,1600)(A(I),I=1,NM3)
C READ STATEMENTS FOR FIXED INPUT DATA FOR CYLINDERS FOLLOWING TANGENT
C OBLIVES
READ(5,9502) NMACH(4)
READ(5,9502) NXD4
NM4=NMACH(4)
READ(5,9502)(NFN4(I),I=1,NM4)
READ(5,9502)(NLAM4(I),I=1,NM4)
READ(5,1600)(MACH(4,I),I=1,NM4)
READ(5,1600)(XD4(J),J=1,NXD4)
DO1507 I=1, NM4
NFN=NFN4(I)
1507 READ(5,1600)(FN4(I,K),K=1,NFN)
DO1508 I=1, NM4
NL=NLAM4(I)
1508 READ(5,1600)(LAM4(I,L),L=1,NL)
C READ STATEMENTS FOR FIXED INPUT DATA FOR CYLINDERS FOLLOWING CONES
READ(5,9502) NMACH(5)
READ(5,9502) NXD5
NM5=NMACH(5)
READ(5,9502)(NTHN5(I),I=1,NM5)
READ(5,9502)(NLAM5(I),I=1,NM5)
READ(5,1600)(MACH(5,I),I=1,NM5)
READ(5,1600)(XD5(J),J=1,NXD5)
DO1505 I=1, NM5
NTN=NTHN5(I)
1505 READ(5,1600)(THN5(I,K),K=1,NTN)
DO1506 I=1, NM5
NL=NLAM5(I)

```

```

1506 READ(5,1600)(LAM5(I,L),L=1,NL)
C READ STATEMENTS FOR FIXED INPUT DATA FOR FRUSTUMS FOLLOWING CONE
C CYLINDERS
      READ(5,9502)NMACH(6)
      READ(5,9502)NXD6
      NM6=NMACH(6)
      READ(5,9502)(NTHN6(I),I=1,NM6)
      DO1509I=1,NM6
      NTN=NTHN6(I)
1509 READ(5,9502)(NTHF6(I,J),J=1,NTN)
      DO1510J=1,NTN
      NTF=NTHF6(I,J)
1510 READ(5,9502)(NFA6(I,J,K),K=1,NTF)
      DO1511I=1,NM6
      NTN=NTHN6(I)
      DO1511J=1,NTN
      NTF=NTHF6(I,J)
1511 READ(5,9502)(NLAM6(I,J,K),K=1,NTF)
      DO1512I=1,NM6
      NTN=NTHN6(I)
1512 READ(5,9502)(NTOTL6(I,J),J=1,NTN)
      DO1513I=1,NM6
      NTN=NTHN6(I)
1513 READ(5,9502)(NTOTFA(I,J),J=1,NTN)
      READ(5,1600)(VACH(6,I),I=1,NM6)
      READ(5,1600)(XD6(L),L=1,NXD6)
      DO1514I=1,NM6
      NTN=NTHN6(I)
1514 READ(5,1600)(THN6(I,J),J=1,NTN)
      DO1515I=1,NM6
      NTN=NTHN6(I)
      DO1515J=1,NTN
      NTF=NTHF6(I,J)
1515 READ(5,1600)(THF6(I,J,K),K=1,NTF)
      DO1526I=1,NM6
      NTN=NTHN6(I)
      DO1526J=1,NTN

```

```

      NTOTF=NTOTFA(I,J)
1526 READ(5,1600)(FA6(I,J,M),M=1,NTOTF)
      DO1516I=1,NM6
      NTN=NTHN6(I)
      DO1516J=1,NTN
      NTOTF=NTOTFA(I,J)
1516 READ(5,9502)(K1(I,J,M),M=1,NTOTF)
      DO1527I=1,NM6
      NTN=NTHN6(I)
      DO1527J=1,NTN
      NTOTL=NTOTL6(I,J)
1527 READ(5,1600)(LAM6(I,J,N),N=1,NTOTL)
C READ STATEMENTS FOR FIXED INPUT DATA FOR CYLINDERS FOLLOWING FRUSTUMS
      READ(5,9502)NMACH(7)
      READ(5,9502)NXD7
      NM7=NMACH(7)
      READ(5,9502)(NDDR7(I),I=1,NM7)
      DO1528I=1,NM7
      ND=NDDR7(I)
1528 READ(5,9502)(NTHF7(I,J),J=1,ND)
      DO1517I=1,NM7
      ND=NDDR7(I)
1517 READ(5,9502)(NLAM7(I,J),J=1,ND)
      READ(5,1600)(MACH(7,I),I=1,NM7)
      READ(5,1600)(XD7(K),K=1,NXD7)
      DO1518I=1,NM7
      ND=NDDR7(I)
1518 READ(5,1600)(DDR7(I,J),J=1,ND)
      DO1529I=1,NM7
      ND=NDDR7(I)
      DO1529J=1,ND
      NTF=NTHF7(I,J)
1529 READ(5,1600)(THF7(I,J,L),L=1,NTF)
      DO1519I=1,NM7
      ND=NDDR7(I)
      DO1519J=1,ND
      NL=NLAM7(I,J)
1519 READ(5,1600)(LAM7(I,J,M),M=1,NL)

```



```

C READ STATEMENTS FOR FIXED INPUT DATA FOR BOATTAILS FOLLOWING LONG
C CYLINDERS
  READ(5,9502)NMACH(8)
  READ(5,9502)NXDB
  NMB=NMACH(8)
  READ(5,9502)(NTHB8(I),I=1,NMB)
  READ(5,9502)(NLAMB(I),I=1,NMB)
  READ(5,1600)(MACH(8,I),I=1,NMB)
  READ(5,1600)(XDB(J),J=1,NXDB)
  DO1520 I=1,NMB
  NTB=NTHB8(I)
1520 READ(5,1600)(THB8(I,K),K=1,NTB)
  DO1521 I=1,NMB
  NL=NLAMB(I)
1521 READ(5,1600)(LAMB(I,L),L=1,NL)
C THE INPUT FOR APPLYING THE PROGRAM TO A PARTICULAR VEHICLE BEGINS
C WITH THE FOLLOWING READ STATEMENT AND CONTINUES THROUGH TEN
C SUCCESSIVE READ STATEMENTS
9016 READ(5,9503)HEAD
  READ(5,9502)NCMPS,NMACHN,NOXS,NDX,NC1,NC2,NC3,NFCYCM,NTHFRR,NPUNCH
  READ(5,1600)THNR,THBR,FAR,FNR
  READ(5,1600)XR4,XR5,XR7,DX4,DX5,DX7,XR1C
  READ(5,1600)(THFRP(N),N=1,NTHFRR)
  READ(5,1600)(DDRR(J),J=1,NFCYCM)
  READ(5,9502)(COMPNO(I),I=1,NCMPS)
  READ(5,9502)(NXS(I),I=1,NCMPS)
  READ(5,1600)(DO(I),I=1,NCMPS)
  READ(5,1600)(MACHN(K),K=1,NMACHN)
  READ(5,1600)(XS(M),M=1,NOXS)
  WRITE(6,9504)HEAD
  WRITE(6,9004)NCMPS,NMACHN,NOXS,NDX,NC1,NC2,NC3,NFCYCM,NTHFRR,NPUNC
1H
  WRITE(6,9005)THNR,THBR,FAR,FNR
  WRITE(6,9007)XR4,XR5,XR7,DX4,DX5,DX7,XR1C
  WRITE(6,9505)(THFRP(N),N=1,NTHFRR)
  WRITE(6,9506)(DDRR(J),J=1,NFCYCM)
  WRITE(6,9010)(COMPNO(I),DO(I),NXS(I),I=1,NCMPS)
  NMI=0
2000 LLL=0

```

```

I7=1
L1=0
J=1
ND=1
LCN=0.
FANS3=0.
MM=0
J5=1
THFR=THFR(J5)
DDR=DDRR(J5)
NMI=NMI+1
IF(NMI-NMACHN)9015,9015,9016
9015 MR=MACHN(NMI)
IF(MR.GE.15.)MR=15.
3000 WRITE(6,9011)MR
NBC1=0
KK2=0
1000 LLL=LLL+1
IF(LLL-NCMPS)536,536,2000
536 N=COMPNO(LLL)
DX=D0(LLL)
NX=NXS(LLL)
KK1=KK2+1
KK2=KK1+NX-1
MM=0
I1=NMACH(N)
GOTO(1,2,3,4,5,6,7,8),N
1 THNR=.01745*THNR
LCN=D0(LLL)/(2.*(SIN(THNR)/COS(THNR)))
DX=LCN
1717 YAR=THNR
K8=NXLI
J1=1
DO1113K=1,NXL1
1113 X(K)=XL1(K)
CALL MACHXD(I1,N,MR,LCN,XR1C,MM,NDX,J1,DDR,I7,THFR,NN1,
XI,NX,ND,MM,J,L1,KK1,KK2,DX,LLL)
1120 K3=NTHN1(I)
DO1119K=1,K3

```

```

1119 YA(K)=THN1(I,K)
      NL=NLAM1(I)
      DO1112K=1,NL
1112 LAM(K)=LAM1(I,K)
      GOTO1075
      2 LCN=FNR*DX
      DX=LCN
917  YAR=FNR
      KB=NXL2
      J1=1
      DO42K=1,NXL2
42  X(K)=XL2(K)
      CALL MACHXD(I1,N,MR,LCN,XR1C,MM,NDX,J1,DDR,I7,THFR,NN1,
      XI,NX,ND,MMM,J,L1,KK1,KK2,DX,LLL)
47  K3=NFN2(I)
      NL=NLAM2(I)
      DO44K=1,K3
44  YA(K)=FN2(I,K)
      YAR=FNR
      DO45K=1,NL
45  LAM(K)=LAM2(I,K)
      GOTO1075
      3 J1=1
      CALL MACHXD(I1,N,MR,LCN,XR1C,MM,NDX,J1,DDR,I7,THFR,NN1,
      XI,NX,ND,MMM,J,L1,KK1,KK2,DX,LLL)
320 IF(NN1.EQ.1)GOTO330
      M1(1)=MACH(3,I)
      Y1(2)=MACH(3,I+1)
      A11(1)=A(I)
      A11(2)=A(I+1)
      CALL DISCOT(MR,MR,M1,A11,A11,-10,2,0,ANS)
340 DO1051K=1,NX
1051 AN3(K)=8.*3.14*DO(LLL)*ANS*(.5-XX(K))*(1.-XX(K))*XX(K)
      NBC1=1
      FANS3=AN3(NX)
      KK3=0
      KKK3=KK2-1
      DO1052K=KK1,KKK3
      KK3=KK3+1

```

```

        WRITE(6,9000)XS(K),AN3(KK3)
        IF(NPUNCH.EQ.1)GOTO555
        GOTO1052
555 PUNCH9000,XS(K),AN3(KK3)
1052 CONTINUE
        GOTO1000
330 ANS=A(I)
        GOTO340
    4 K8=NXD4
        J1=1
61 D062K=1,NXD4
62 X(K)=XD4(K)
        CALL MACHXD(I1,N,MR,LCN,XR1C,MM,NDX,J1,DDR,I7,THFR,NN1,
        XI,NX,ND,MMM,J,L1, <<K1, <<K2,DX,LLL)
        IF(NN1.EQ.1)GOTO610
        IF(((MACH(4,1).GE.1.35).OR.(MACH(4,1).LT.1.35.AND.MACH(4,2).GT.
        X1.35)).AND.(MR.LE.1.35))GOTO63
610 K3=NFN4(I)
        NL=NLAM4(I)
        D064K=1,K3
64 YA(K)=FN4(I,K)
        YAR=FNR
        D065K=1,NL
65 LAM(K)=LAM4(I,K)
        GOTO1075
63 WRITE(6,9003)
        GOTO1000
    5 YAR=THNR
        K8=NXD5
        J1=1
        D052K=1,NXD5
52 X(K)=XD5(K)
        CALL MACHXD(I1,N,MR,LCN,XR1C,MM,NDX,J1,DDR,I7,THFR,NN1,
        XI,NX,ND,MMM,J,L1, <<K1, <<K2,DX,LLL)
520 K3=NTHN5(I)
        NL=NLAM5(I)
        D05532K=1,K3
5532 YA(K)=THN5(I,K)
        D05533K=1,NL

```

```

5533 LAM(K)=LAM5(I,K)
1075 CALL INTP(N,NX,YAR,NL,K8,NN1,J1,I,LCN,FNR,FANS2,FANS3,MR,NC1,
      XXR4,DX4,NDX,NC2,XR5,DX5,KK1,KK2,LLL,MM,NBC1,NPUNCH)
      IF(NN1.EQ.1.OR.J1.GT.2)GOTO775
1013 IF(N.EQ.1)GOTO1120
      IF(N.EQ.2)GOTO47
      IF(N.EQ.5.OR.N.EQ.6.OR.N.EQ.7)GOTO520
      IF(N.EQ.4)GOTO610
      IF(N.EQ.8)GOTO1304
775 IF(N.EQ.6)GOTO8276
      IF(N.EQ.7)GOTO1750
      GOTO1000
1750 MR=MR7
      NN1=NN707
      I=I7
      IF(((DDR-DDR7(I,1)).LT.-.1E-7).AND.L1.EQ.1)GOTO1059
      IF(((DDR-DDR7(I,1)).LT.-.1E-7).AND.L1.EQ.2.AND.((THFR-THF7(I,J,1
X)).LT.-.1E-7))GOTO1751
      IF((THFR-THF7(I,J,1)).LT.-.1E-7)GOTO1751
      IF((DDR-DDR7(I,ND)).GT..1E-7)GOTO1060
1751 NBC=1
      DO1061K2=1,NX
      XX(K2)=XX7(K2)
1061 AA1(K2)=A4(K2)
      THFR=THF7(I,J,1)
      GOTO1062
1059 THNR=THNR1
      DO1067K2=1,NX
1067 A1(1,K2)=A4(K2)
      GOTO1053
1060 DO1065K2=1,NX
      A1(2,K2)=A4(K2)
1065 XX(K2)=XX7(K2)
      GOTO1053
8276 DO7728K2=1,NX
      XX(K2)=XX6(K2)
7728 A1(1,K2)=A4(K2)
      NBC=1
      GOTO8275

```

```

6 MM=6
  THFR1=.01745*THFR
  NN2=0
  J1=1
  IF((FAR-4.)*GE.-.1E-7)FAR=4.
  CALL MACHXD(I1,N,MR,LCN,XR1C,MM,NDX,J1,DDR,I7,THFR,NN1,
XI,NX,ND,MMM,J,L1,<<1,KK2,DX,LLL)
8103 L1=1
      L2=1
      L3=1
      L4=1
      E1=0.
      E2=0.
      E3=0.
      E4=0.
      NN3=0
      NN4=0
      NBC=0
250 NTN=NTHN6(I)
    DO251J=1,NTN
      IF(ABS(THNR-THN6(I,J)).LE..1E-7)GOTO252
251 CONTINUE
      IF(THNR.LT.THN6(I,1))GOTO253
      DO9135J=2,NTN
        IF(THNR.LT.THN6(I,J))GOTO254
9135 CONTINUE
      J=NTN-1
      GOTO8254
253 J=1
      GOTO8254
254 J=J-1
      GOTO8254
252 J=J
      NN2=1
8254 NTF=NTHF6(I,J)
      DO8257K=1,NTF
        IF(ABS(THFR-THF6(I,J,K)).LE..1E-7)GOTO8258
8257 CONTINUE
8256 IF(THFR.LT.THF6(I,J,1))GOTO8260

```

```

      D08268K=2,NTF
      IF (THFR.LT.TH6(I,J,K))GOTO8255
8268 CONTINUE
      K=NTF-1
      GOTO8261
8255 K=K-1
      GOTO8261
8258 K=K
      NN3=1
      GOTO8261
8260 D08270K2=1,NX
8270 XX6(K2)=XX(K2)
8273 NN606=NN1
      THNRS=THNR
      THNR=THN6(I,J)
      THFRS=THFR
      I6=I
      MR6=MR
      MR=MACH(6,I)
      I1=NMACH(5)
      N=5
      GOTO5
8275 I=I6
      NN1=NN606
      THNR=THNRS
      THFR=TH6(I,J,1)
      MR=MR6
      L1=2
      K=1
8261 IF (K.EQ.1)GOTO8755
      LL1=1
      LL2=0
      LL3=1
      LL4=0
      KK=K-1
      D01999L=1,KK
      LL1=LL1+NLAM6(I,J,L)
1999 LL3=LL3+NFA6(I,J,L)
      D02002L=1,K

```

```

      LL2=LL2+NLAM6(I,J,L)
2002 LL4=LL4+NFA6(I,J,L)
      GOTO8002
8755 LL1=1
      LL2=NLAM6(I,J,1)
      LL3=1
      LL4=NFA6(I,J,1)
8002 NL=0
      DO8003L=LL1,LL2
      NL=NL+1
8003 LAM(NL)=LAM6(I,J,L)
      NF=0
      DO8004L=LL3,LL4
      NF=NF+1
      FA(NF)=FA6(I,J,L)
8004 K11(NF)=K1(I,J,L)
      DO801K2=1,NX
      XX1=XX(K2)
      CALL DISCOT(FAR,XX1,FA,LAM,XD6,11,NL,NXD6,ANS1)
801  A1(L1,K2)=ANS1
      DO8901L=1,NF
      IF(ABS(FAR-FA(L)).LE..1E-7)GOTO8903
8901 CONTINUE
      IF(FAR.LT.FA(1))GOTO8902
      DO81L=2,NF
      IF(FAR.LT.FA(L))GOTO8904
81   CONTINUE
      L=NF-1
      GOTO8905
8902 L=1
      GOTO8905
8904 L=L-1
      GOTO8905
8903 L=L
      NN4=1
8905 IF(NN4.EQ.1)GOTO8906
      IF(K11(L).EQ.1.AND.K11(L+1).EQ.1)GOTO259
      IF(K11(L).EQ.0.AND.K11(L+1).EQ.0)GOTO815
      IF(K11(L).EQ.0.AND.K11(L+1).EQ.1)GOTO8909

```



```

      IF (K11(L).EQ.1.AND.K11(L+1).EQ.0)GOTO8910
8906 IF (K11(L).EQ.0)GOTO815
      GOTO259
8909 K6=L
      802 K5=NL
          K3=NF
          GOTO814
8910 K6=L+1
      GOTO802
815  E1=E1+1.
      MN11=L1
      GOTO259
814  DO816NN=K6,K5,K3
816  LAM(NN)=1.1*LAM(NN)
      XX1=XX(1)
      CALL DISCOT(FAR,XX1,FA,LAM,XD6,11,NL,NXD6,ANS2)
      IF (ABS((A1(L1,1)-ANS2)/A1(L1,1)).LE..02)GOTO259
      E1=E1+1.
      MN11=L1
259  IF (NN3.EQ.1)GOTO260
      L1=L1+1
      IF (L1-2)2588,2588,261
2588 K=K+1
      GOTO8261
261  IF (NBC.EQ.1)GOTO807
      THF(1)=THF6(I,J,K-1)
      THF(2)=THF6(I,J,K)
      GOTO808
807  THF(1)=0.
      THF(2)=THF6(I,J,1)
      THFR=THFRS
808  DO803K2=1,NX
          A11(1)=A1(1,K2)
          A11(2)=A1(2,K2)
          CALL DISCOT(THFR,THFR,THF,A11,A11,-10,2,0,ANS1)
803  A2(L2,K2)=ANS1
      IF (E1.LE..1E-7)GOTO262
      IF ((E1-1.0).LE..1E-7)GOTO805
806  E2=E2+1.

```

```

      MN11=L2
      GOTO262
805  A11(MN11)=1.1*A1(MN11,1)
      CALL DISCOT(THFR,THFR,THF,A11,A11,-10,2,0,ANS2)
      IF(ABS((A2(L2,1)-ANS2)/A2(L2,1)).LE..02)GOTO262
      GOTO806
260  DO263K2=1,NX
263  A2(L2,K2)=A1(L1,<2)
      E2=E1
262  IF(NN2.EQ.1)GOTO265
      L2=L2+1
      IF(L2-2)266,266,267
266  L1=1
      J=J+1. NN3=0
      F1=0.
      GOTO8254
267  TN(1)=THN6(I,J-1)
      TN(2)=THN6(I,J)
      DO8077K2=1,NX
      A22(1)=A2(1,K2)
      A22(2)=A2(2,K2)
      CALL DISCOT(THNR,THNR,TN,A22,A22,-10,2,0,ANS1)
8077 A3(L3,K2)=ANS1
      IF(E2.LE..1E-7)GOTO268
      IF((E2-1.)*LE..1E-7)GOTO8808
809  E3=E3+1.
      MN11=L3
      GOTO268
8808 A22(MN11)=1.1*A2(MN11,1)
      CALL DISCOT(THNR,THNR,TN,A22,A22,-10,2,0,ANS2)
      IF(ABS((A3(L3,1)-ANS2)/A3(L3,1)).LE..02)GOTO268
      GOTO809
265  DO270K2=1,NX
270  A3(L3,K2)=A2(L2,K2)
      E3=E2
268  IF(NN1.EQ.1)GOTO271
      L3=L3+1
      IF(L3-2)272,272,273
272  I=I+1

```

```

L1=1
L2=1
E1=0. N.A2=0
E2=0. N.N3=0
GOTO250
271 D0274K2=1,NX
274 A4(K2)=A3(L3,K2)
E4=E3
GOTO277
273 M1(1)=MACH(6,I-1)
M1(2)=MACH(6,I)
D08672K2=1,NX
A33(1)=A3(1,K2)
A33(2)=A3(2,K2)
CALL DISCOT(MR,MR,M1,A33,A33,-10,2,0,ANS1)
8672 A4(K2)=ANS1
IF(E3.LE..1E-7)GOTO277
IF((E3-1.)LE..1E-7)GOTO278
E4=E4+1.
GOTO277
278 A33(MN11)=1.1*A3(MN11,1)
CALL DISCOT(MR,MR,M1,A33,A33,-10,2,0,ANS2)
IF(ABS((A4(1)-ANS2)/A4(1)).LE..02)GOTO277
E4=E4+1.
277 KK3=0
D08277K2=KK1,KK2
KK3=KK3+1
DX=D0(LLL)*(1.+2.*XX(KK3)*SIN(THFR1)/COS(THFR1))
ANS=DX*A4(KK3)
WRITE(6,9000)XS(K2),ANS
IF(NPUNCH.EQ.1)GOTO556
GOTO8277
556 PUNCH9000,XS(K2),ANS
8277 CONTINUE
GOTO1000
7 MM=7
1049 NBC=0
L1=1

```

```

      L2=1
      NN2=0
      CALL MACHXD(I1,N,MR,LCN,XR1C,MM,NDX,J1,DDR,I7,THFR,NN1,
      XI,NX,ND,MMM,J,L1,<K1,KK2,DX,LLL)
1021 ND=NDDR7(I)
      IF((DDR-DDR7(I,1)).LT.-.1E-7)GOTO1057
      DO1077J=1,ND
      IF(ABS(DDR-DDR7(I,J)).LE..1E-7)GOTO1027
1077 CONTINUE
      IF(ND.GE.2)GOTO1776
      J=1
      GOTO1035
1776 DO1028J=2,ND
      IF(DDR.LT.DDR7(I,J))GOTO1011
1028 CONTINUE
1029 J=ND
      GOTO1035
1011 J=J-1
      GOTO1035
1027 J=J
      NN2=1
1035 IF((THFR-THF7(I,J,1)).LT.-.1E-7)GOTO1050
      GOTO1062
1050 THFR1=THFR
      I7=I
      DO1012K=1,NX
1012 XX7(K)=XX(K)
1063 NN707=NN1
      MR7=MR
      MR=MACH(7,I)
      I1=NMACH(5)
      N=5
      GOTO5
1057 THNR1=THNR
      THNR=THFR
      I7=I
1058 DO1775K=1,NX
1775 XX7(K)=XX(K)

```

```

      GOTO1063
1062 NTF=NTHF7(I,J)
      NL=NLAM7(I,J)
      DO1064L=1,NTF
1064 THF(L)=THF7(I,J,L)
      DO1079L=1,NL
1079 LAM(L)=LAM7(I,J,L)
      DO1055K2=1,NX
      XX1=XX(K2)
      CALL DISCOT(THFR,XX1,THF,LAM,XD7,11,NL,NXD7,ANS)
1055 A1(L1,K2)=ANS
      IF(NBC.EQ.1)GOTO1089
      GOTO1053
1089 THFR=THFR1
      THF(1)=0.
      THF(2)=THF7(I,J,1)
      DO777K2=1,NX
      AA2(1)=AA1(K2)
      AA2(2)=A1(L1,K2)
      CALL DISCOT(THFR,THFR,THF,AA2,AA2,-10,2,0,ANS)
      777 A1(L1,K2)=ANS
1053 IF(NN2.EQ.1)GOTO1086
      L1=L1+1
      IF(L1-2)1045,1045,1088
1045 IF(((DDR-DDR7(I,1)).LT.-.1E-7)GOTO1048
      IF(((DDR-DDR7(I,ND)).GT..1E-7).AND.((THFR-THF7(I,J,1)).LT.
X-.1E-7))GOTO1046
      IF(((DDR-DDR7(I,ND)).GT..1E-7)GOTO1050
      J=J+1
      GOTO1035
1048 J=1
      GOTO1035
1046 DO1047K2=1,NX
1047 A1(L1,K2)=AA1(K2)
1088 IF(((DDR-DDR7(I,1)).LT.-.1E-7)GOTO1068
      IF(((DDR-DDR7(I,ND)).GT..1E-7)GOTO1070
      D2(1)=DDR7(I,J-1)
      D2(2)=DDR7(I,J)

```

```

1069 DO1098K2=1,NX
      A11(1)=A1(1,K2)
      A11(2)=A1(2,K2)
      CALL DISCOT(DDR,DDR,D2,A11,A11,-10,2,0,ANS)
1098 A2(L2,K2)=ANS
      GOTO1085
1068 D2(1)=0.
      D2(2)=DDR7(1,1)
      GOTO1069
1070 D2(1)=DDR7(1,N0)
      D2(2)=1.
      GOTO1069
1086 DO1087K2=1,NX
1087 A2(L2,K2)=A1(1,K2)
1085 IF(NM1.EQ.1)GOTO1091
      L2=L2+1
      IF(L2-2)1092,1092,1093
1092 L1=1
      NN2=0
      I=I+1
      GOTO1021
1093 M1(1)=MACH(7,I-1)
      M1(2)=MACH(7,I)
      DO1094K2=1,NX
      A12(1)=A2(1,K2)
      A12(2)=A2(2,K2)
      CALL DISCOT(MR,MR,M1,A12,A12,-10,2,0,ANS)
1094 A4(K2)=ANS
      GOTO1097
1091 KK3=0
      DO1099K2=KK1,KK2
      KK3=KK3+1
1099 A4(KK3)=A2(1,KK3)
1097 KK3=0
      DO1096K2=KK1,KK2
      KK3=KK3+1
      IF(J5.EQ.NFCYCM)GOTO1250
      GOTO1231
1250 IF(NC3.EQ.1)GOTO1228

```

```

1231 ANS=A4(KK3)*DX
      GOTO1227
1228 IF (ABS(XS(K2)-XR7).LE..1E-7)GOTO1229
      GOTO1232
1230 ANS=A4(KK3)*DX7
1227 WRITE(6,9000)XS(K2),ANS
      IF(NPUNCH.EQ.1)GOTO557
      GOTO1096
      557 PUNCH9000,XS(K2),ANS
          GOTO1096
1229 ANS=A4(KK3)*DX
      WRITE(6,9000)XS(K2),ANS
      IF(NPUNCH.EQ.1)GOTO558
      GOTO1230
      558 PUNCH9000,XS(K2),ANS
          GOTO1230
1232 IF ((NDX.EQ.0.AND.XS(K2).GT.XR7).OR.(NDX.EQ.1.AND.XS(K2).LT.XR7))
      XGOTO1230
      GOTO1231
1096 CONTINUE
      IF(NFCYCM.GT.1)GOTO1292
      GOTO1000
1292 J5=J5+1
      IF(J5.GT.NFCYCM)GOTO1000
      THFR=THFR(J5)
      DDR=DDRR(J5)
      FAR=4.5
      GOTO1000
      8 YAR=THBR
        K8=NXD8
        J1=1
        D01301K=1,NXD8
1301 X(K)=XD8(K)
      CALL MACHXD(I1,N,MR,LCN,XR1C,MM,NDX,J1,DDR,I7,THFR,NN1,
      XI,NX,ND,MM,J,L1,KK1,KK2,DX,LLL)
      IF(NN1.EQ.1)GOTO1304
      IF(((MACH(8,1).GE.1.35).OR.(MACH(8,1).LT.1.35.AND.MACH(8,2).GT.
      X1.35)).AND.(MR.LE.1.35))GOTO91
1304 K3=NTHB8(I)

```

```

      D01302K=1,K3
1302 YA(K)=THB8(I,K)
      NL=NLAM8(I)
      D01303K=1,NL
1303 LAM(K)=LAM8(I,K)
      GOTO1075
      91 WRITE(6,9006)
      GOTO1000
1600 FORMAT(10F7.3)
9000 FORMAT(2E16.8)
9001 FORMAT(1X66HTHE DLAMBDA VALUES FOR THE FRUSTUM ARE ESTIMATED FOR T
      HIS MACH NO.)
9005 FORMAT(1X5HTHNR=F8.3,3X5HTHNR=F8.3,2X4HFAR=F8.3,4X4HFNR=F8.3)
9007 FORMAT(1X4HXR4=F9.3,3X4HXR5=F9.3,2X4HXR7=F8.3,4X4HDX4=F8.3,
      X3X4HDX5=F8.3,3X4HDX7=F7.3,4X5HXR1C=F8.3)
9502 FORMAT(14I5)
9503 FORMAT(1X11A6)
9504 FORMAT(1H1,11A6/40X16HINPUT PARAMETERS)
9004 FORMAT(1X6HNCMP5=I5,5X7HNMACHN=I5,3X5HNOXS=I5,6X4HNDX=I5,6X4HNC1=I
      12,3X4HNC2=I2,3X4HNC3=I2,3X7HNFCYCM=I2,3X7HNTHFRR=I2,3X7HNPUNCH=I2)
9010 FORMAT(1X/1X9HCOMPNO(I)5X5HD0(I)5X6HNXS(I)/(15,7XF8.3,4X15))
9011 FORMAT(1X/1X5HMACH=F7.3//6X7HSTATION9X7HDLAMBDA)
9003 FORMAT(1X101HNO FIXED INPUT DATA FOR CYLINDER FOLLOWING OGIVE IN S
      1UBSONIC AND TRANSONIC RANGE ARE INPUT TO PROGRAM)
9006 FORMAT(1X109HNO FIXED INPUT DATA FOR BOATTAIL FOLLOWING LONG CYLIN
      1DER IN SUBSONIC AND TRANSONIC RANGE ARE INPUT TO PROGRAM)
9505 FORMAT(1X/5X8HTHFRR(I)/(1X5F8.3))
9506 FORMAT(1X/5X7HD0RR(I)/(1X5F8.3))
      END

```



```

SUBROUTINE MACHXD(I1,N,MR,LCN,XR1C,MM,NDX,J1,DDR,I7,
XTHFR,NN1,I,NX,ND,MMM,J,L1,KK1,KK2,DX,LLL)
C CALCULATION OF MACH NUMBERS USED IN INTERPOLATION AND CONVERSION OF
C STATIONS INTO X/DO OR X/L VALUES
REAL MACH,M1,LCN,MACHN,LAM1,LAM2,LAM5,LAM6,LAM7,LAM8,LAM,MR
COMMON NMACH(8),NTHN1(14),NLAM1(14),MACH(8,16),THN1(14,17),XL1(6),
1LAM1(14,102),NLAM2(7),NFN2(7),XL2(21),FN2(7,5),LAM2(7,105),A(12),
2NLAM4(5),NFN4(5),XD4(14),FN4(5,3),LAM4(5,42),NLAM5(16),NTHN5(16),
3XD5(24),THN5(16,9),LAM5(16,215),NTHN6(8),NTHF6(8,3),
4NFA6(8,3,4),NLAM6(8,3,4),NTOTL6(8,3),NTOTFA(8,3),THN6(8,3),
5XD6(18),THF6(8,3,4),LAM6(8,3,288),FA6(8,3,16),K1(8,3,16),
6NDDR7(8),NTHF7(8,3),NLAM7(8,3),DDR7(8,3),THF7(8,3,4),LAM7(8,3,96),
7XD7(24),NTHR8(8),THR8(8,5),XD8(12),LAM8(8,60),NLAM8(8)
COMMON HEAD(11),XX(100),X(25),LAM(225),NXS(14),XS(350),DO(14),
1A1(2,100),YA(17),TN(2),MACHN(15)
COMMON A2(2,100),A3(2,100),M1(2),A11(2),A4(100),AA1(100),
1AN3(5),XX6(100),FA(4),K11(4),THF(4),A22(2),A33(2),XX7(100),AA2(2),
2D2(2),A12(2),COMPNO(14),A44(2,100),THFRR(5),DDRR(5)
100 NN1=0
DO101 I=1, I1
IF (ABS(MACH(N,I)-MR).LE..1E-7)GOTO102
101 CONTINUE
GOTO103
102 NN1=1
I=I
GOTO104
103 IF(MR.LT.MACH(N,1))GOTO105
IF(MR.GT.MACH(N,I1))GOTO106
DO107 I=1, I1
IF(MR-MACH(N,I))108,108,107
107 CONTINUE
108 I=I-1
GOTO104
105 I=1
GOTO104
106 I=I1-1
104 IF(N.EQ.5)GOTO4113
GOTO4112
4113 IF(MM.EQ.6)GOTO4115

```

```

      IF (MM.EQ.7.AND.((DDR-DDR7(I7,1)).LT.-.1E-7).AND.(L1.EQ.1)
X)GOTO4121
      IF (MM.EQ.7.AND.((DDR-DDR7(I7,1)).LT.-.1E-7).AND.L1.EQ.2.AND.
X((THFR-THF7(I7,J,1)).LT.-.1E-7))GOTO4122
      IF ((MM.EQ.7).AND.((THFR-THF7(I7,J,1)).LT.-.1E-7))GOTO4122
      IF ((MM.EQ.7).AND.((DDR-DDR7(I7,ND)).GT..1E-7))GOTO4122
      GOTO4112
4115 N=6
      XR1=XR1C
      GOTO4109
4121 N=7
      GOTO4112
4122 N=7
      XR1=XR1C
      GOTO4109
4112 IF (N.EQ.1.OR.N.EQ.2)GOTO4104
      XR1=XS(KK1)
4109 IF (NDX.EQ.1)GOTO4107
      KK3=0
      D04106K=KK1, KK2
      KK3=KK3+1
4106 XX(KK3)=(XS(K)-XR1)/DX
      GOTO110
4107 KK3=0
      D04108K=KK1, KK2
      KK3=KK3+1
4108 XX(KK3)=(XR1-XS(K))/DX
      GOTO110
4104 IF (NDX.EQ.0)XR1=XS(KK2)-LCN
      IF (NDX.EQ.1)XR1=XS(KK2)+LCN
      GOTO4109
110 RETURN
      FND

```

```

SUBROUTINE INTP(N,NX,YAR,NL,K8,NN1,J1,I,LCN,FNR,FANS2,FANS3,MR,
XNC1,XR4,DX4,NDX,NC2,XR5,DX5,KK1,KK2,LLL,MM,NBC1,NPUNCH)
C INTERPOLATION ROUTINE FOR COMPONENTS 1,2,4,5, AND 8
REAL MACH,MR,M1,LCN,MACHN,LAM1,LAM2,LAM4,LAM5,LAM6,LAM7,LAM8,LAM
COMMON NMACH(8),NTHN1(14),NLAM1(14),MACH(8,16),THN1(14,17),XL1(6),
1 LAM1(14,102),NLAM2(7),NFN2(7),XL2(21),FN2(7,5),LAM2(7,105),A(12),
2 NLAM4(5),NFN4(5),XD4(14),FN4(5,3),LAM4(5,42),NLAM5(16),NTHN5(16),
3 XD5(24),THN5(16,9),LAM5(16,216),NTHN6(8),NTHF6(8,3),
4 NFNA6(8,3,4),NLAM6(8,3,4),NTOTL6(8,3),NTOTFA(8,3),THN6(8,3),
5 XD6(18),THF6(8,3,4),LAM6(8,3,288),FA6(8,3,16),K1(8,3,16),
6 NDDR7(8),NTHF7(8,3),NLAM7(8,3),DDR7(8,3),THF7(8,3,4),LAM7(8,3,96),
7 XD7(24),NTHB8(8),THB8(8,5),XDB(12),LAM8(8,60),NLAM8(8)
COMMON HEAD(11),XX(100),X(25),LAM(225),NXS(14),XS(350),D0(14),
1 A1(2,100),YA(17),TN(2),MACHN(15)
COMMON A2(2,100),A3(2,100),M1(2),A11(2),A4(100),AA1(100),
1 AN3(5),XX6(100),FA(4),K11(4),THF(4),A22(2),A33(2),XX7(100),AA2(2),
2 D2(2),A12(2),COMPNO(14),A44(2,100),THFRR(5),DDRR(5)
D01076K2=1,NX
XX1=XX(K2)
CALL DISCOT(YAR,XX1,YA,LAM,X,11,NL,K8,ANS)
1076 A44(J1,K2)=ANS
1011 IF(NN1.EQ.1)GOTO1015
J1=J1+1
IF(J1-2)1013,1013,1014
1013 I=I+1
RETURN
1014 IF(MM.EQ.6.OR.MM.EQ.7)N=5
M1(1)=MACH(N,I-1)
M1(2)=MACH(N,I)
D05108K2=1,NX
A11(1)=A44(1,K2)
A11(2)=A44(2,K2)
CALL DISCOT(MR,MR,M1,A11,A11,-10,2,0,ANS)
5108 A4(K2)=ANS
GOTO5109
1015 D01016K2=1,NX
1016 A4(K2)=A44(1,K2)
5109 KK3=0

```

```

IF (MM.EQ.6.OR.MM.EQ.7)N=MM
D05110K2=KK1, KK2
KK3=KK3+1
IF (N.EQ.1)GOTO916
IF (N.EQ.2)GOTO1017
IF (N.EQ.4.OR.N.EQ.5)GOTO1020
IF (N.EQ.6.OR.N.EQ.7)GOTO5110
IF (N.EQ.8)GOTO1305
916 THNR1=.01745*YAR
DX=2.*(SIN (THNR1)/COS (THNR1))*XX (KK3)*LCN
GOTO1019
1017 DX=2.*D0 (LLL)*( .25-FNR**2+SQRT ((FNR**2+.25)**2-(XX (KK3)*FNR-FNR
1)**2))
GOTO1019
1305 THBR1=.01745*YAR
DX=D0 (LLL)*(1.-2.*XX (KK3)*SIN (THBR1)/COS (THBR1))
GOTO1019
1020 DX=D0 (LLL)
1019 ANS=DX*A4 (KK3)
IF (N.EQ.1)GOTO774
IF (N.EQ.2)GOTO776
IF (N.EQ.4)GOTO779
IF (N.EQ.5)GOTO778
IF (N.EQ.8)GOTO782
774 IF (NBC1.EQ.1.AND.KK3.EQ.1)ANS=(ANS+FANS3)/2.
WRITE (6,9000)XS (K2),ANS
IF (NPUNCH.EQ.1)GOTO555
GOTO5110
555 PUNCH9000,XS (K2),ANS
GOTO5110
776 IF (NBC1.EQ.1.AND.KK3.EQ.1)GOTO605
IF (KK3.EQ.NX)GOTO777
WRITE (6,9000)XS (K2),ANS
IF (NPUNCH.EQ.1)GOTO562
GOTO5110
562 PUNCH9000,XS (K2),ANS
GOTO5110
777 FANS2=ANS

```

```

GOTO5110
605 ANS=(FANS3+ANS)/2.
WRITE(6,9000)XS(K2),ANS
IF(NPUNCH.EQ.1)GOTO556
GOTO5110
556 PUNCH9000,XS(K2),ANS
GOTO5110
778 IF(NC1.EQ.1)GOTO1228
GOTO1227
1228 IF(ABS(XS(K2)-XR5).LE..1E-7)GOTO1229
IF((NDX.EQ.0.AND.XS(K2).GT.XR5).OR.(NDX.EQ.1.AND.XS(K2).LT.
XXR5))GOTO1230
GOTO1227
1229 WRITE(6,9000)XS(K2),ANS
IF(NPUNCH.EQ.1)GOTO557
1230 ANS=ANS/DX*DX5
1227 WRITE(6,9000)XS(K2),ANS
IF(NPUNCH.EQ.1)GOTO560
GOTO5110
557 PUNCH9000,XS(K2),ANS
GOTO1230
560 PUNCH9000,XS(K2),ANS
GOTO5110
779 IF(KK3.EQ.1)GOTO6111
IF(NC2.EQ.1)GOTO1328
1327 WRITE(6,9000)XS(K2),ANS
IF(NPUNCH.EQ.1)GOTO558
GOTO5110
558 PUNCH9000,XS(K2),ANS
GOTO5110
6111 ANS=(FANS2+ANS)/2.
GOTO1327
1328 IF(ABS(XS(K2)-XR4).LE..1E-7)GOTO1329
IF((NDX.EQ.0.AND.XS(K2).GT.XR4).OR.(NDX.EQ.1.AND.XS(K2).
XLT.XR4))GOTO1330
GOTO1327
1329 WRITE(6,9000)XS(K2),ANS
IF(NPUNCH.EQ.1)GOTO559
1330 ANS=ANS/DX*DX4

```

```

782 WRITE(6,9000)XS(K2),ANS
      IF(NPUNCH.EQ.1)GOTO561
      GOTO5110
559 PUNCH9000,XS(K2),ANS
      GOTO1330
561 PUNCH9000,XS(K2),ANS
5110 CONTINUE
      RETURN
9000 FORMAT(2E16.8)
      END

```

```

SUBROUTINE DISCOT (XA,ZA,TABX,TABY,TABZ,NC,NY,NZ,ANS)
C THE DIMENSIONS IN THIS SUBROUTINE ARE ONLY DUMMY DIMENSIONS.
  DIMENSION TABX(2),TABY(2),TABZ(2),NPX(8),NPY(8),YY(8)
C DIMENSION TABX(2),TABY(2),TABZ(2),NPX(8),NPY(8),YY(8)
  CALL UNS (NC,IA,IDX,IDZ,IMS)
  IF (NZ-1) 5,5,10
  5 CALL DISSER (XA,TABX(1),1,NY,IDX,NN)
  NNN=IDX+1
  CALL LAGRAN (XA,TABX(NN),TABY(NN),NNN,ANS)
  GOTO 70
10 ZARG=ZA
  IP1X=IDX+1
  IP1Z=IDZ+1
  IF (IA) 15,25,15
  15 IF (ZARG-TABZ(NZ)) 25,25,20
  20 ZARG=TABZ(NZ)
  25 CALL DISSER (ZARG,TABZ(1),1,NZ,IDZ,NPZ)
  NX=NY/NZ
  NPZL=NPZ+IDZ
  I=1
  IF (IMS) 30,30,40
  30 CALL DISSER (XA,TABX(1),1,NX,IDX,NPX(1))
  DO 35 JJ=NPZ,NPZL
  NPY(I)=(JJ-1)*NX+NPX(1)
  NPX(I)=NPX(1)

```

```

35 I=I+1
   GOTO 50
40 DO 45 JJ=NPZ,NPZL
   IS=(JJ-I)*NX+1
   CALL DISSER (XA,TABX(I),IS,NX,IDX,NPX(I))
   NPY(I)=NPX(I)
45 I=I+1
50 DO 55 I=I,IPIZ
   NLOC=NPX(I)
   NLOCY=NPY(I)
55 CALL LAGRAN (XA,TABX(NLOC),TABY(NLOCY),IP1X,YY(I))
   CALL LAGRAN (ZARG,TABZ(NPZ),YY(I),IPIZ,ANS)
70 RETURN
   END

```

```

SUBROUTINE UNS (IC,IA,IDX,IDZ,IMS)
  IF (IC) 5,5,10
  5 IMS=1
   NC=-IC
   GOTO 15
 10 IMS=0
   NC=IC
 15 IF (NC-100) 20,25,25
 20 IA=0
   GOTO 30
 25 IA=1
   NC=NC-100
 30 IDX=NC/10
   IDZ=NC-IDX*10
   RETURN
   END

```

```

SUBROUTINE LAGRAN (XA,X,Y,N,ANS)
DIMENSION X(2),Y(2)
C DIMENSION X(2),Y(2)
SUM=0.0
DO 3 I=1,N
PROD=Y(I)
DO 2 J=1,N
A=X(I)-X(J)
IF (A) 1,2,1
1 B=(XA-X(J))/A
PROD=PROD*B
2 CONTINUE
3 SUM=SUM+PROD
ANS=SUM
RETURN
END

```

```

SUBROUTINE DISSER (XA,TAB,I,NX,ID,NPX)
DIMENSION TAB(2)
C DIMENSION TAB(2)
NPT=ID+1
NPB=NPB/2
NPU=NPT-NPB
IF (NX-NPT) 10,5,10
5 NPX=I
RETURN
10 NLOW=I+NPB
NUPP=I+NX-(NPU+1)
DO 15 II=NLOW,NUPP
NLOC=II
IF (TAB(II)-XA) 15,20,20
15 CONTINUE
NPX=NUPP-NPB+1
RETURN
20 NL=NLOC-NPB
NU=NL+ID

```



```
DO 25 JJ=NL,NU
  NDIS=JJ
  IF (TAB(JJ)-TAB(JJ+1)) 25,30,25
25 CONTINUE
  NPX=NL
  RETURN
30 IF (TAB(NDIS)-XA) 40,35,35
35 NPX=NDIS-ID
  RETURN
40 NPX=NDIS+1
  RETURN
END
```

APPENDIX B

FIXED INPUT DATA LISTING

FIXED INPUT DATA FOR SHARP CONES

```

NMACH(1)
  14
NXL1
  6
NTHN1(I),I=1,14
  6   5   8   7   7  10  11  11  12  16  16  17  17  17
NLAM1(I),I=1,14
  35  30  48  42  42  60  66  66  72  96  96 102 102 102
MACH(1,I),I=1,14
  .700  .800  .900  .950  1.000  1.100  1.200  1.500  2.000  2.500
  3.000  3.500  4.000 15.000
XL1(J),J=1,6
  .0   .2   .4   .6   .8   1.0
THN1(I,J),I=1,14 J=1,NTHN1(I)
  0.0  10.0  15.0  25.0  33.0  40.0
  0.0  10.0  20.0  30.0  40.0
  0.0  10.0  15.0  20.0  25.0  30.0  33.0  40.0
  0.0  10.0  15.0  20.0  25.0  33.0  40.0
  0.0  2.5  10.0  20.0  25.0  33.0  40.0
  0.0  2.5  5.0  7.5  10.0  20.0  25.0  30.0  33.0  40.0
  0.0  2.5  5.0  7.5  10.0  15.0  20.0  25.0  30.0  33.0
40.0
  0.0  2.5  5.0  7.5  10.0  15.0  20.0  25.0  30.0  33.0
40.0
  0.0  2.5  5.0  7.5  10.0  15.0  20.0  25.0  30.0  33.0
35.0  40.0
  0.0  2.5  5.0  7.5  10.0  12.5  15.0  17.5  20.0  22.5
25.0  27.5  30.0  35.0  40.0  45.0
  0.0  2.5  5.0  7.5  10.0  12.5  15.0  17.5  20.0  22.5
25.0  27.5  30.0  35.0  40.0  45.0
  0.0  2.5  5.0  7.5  10.0  12.5  15.0  17.5  20.0  22.5
25.0  27.5  30.0  35.0  40.0  45.0  50.0
  0.0  2.5  5.0  7.5  10.0  12.5  15.0  17.5  20.0  22.5
25.0  27.5  30.0  35.0  40.0  45.0  50.0
  0.0  2.5  5.0  7.5  10.0  12.5  15.0  17.5  20.0  22.5
25.0  27.5  30.0  35.0  40.0  45.0  50.0

```

LAM1(1,J),J=1,36										
.00	.00	.00	.00	.00	.00	.01	.98	1.57	2.04	
2.28	1.96	.01	1.04	1.45	2.51	2.02	1.98	.01	1.09	
1.48	1.94	1.94	1.87	.01	1.02	1.36	1.66	1.70	1.57	
.01	.98	1.26	1.07	.72	.35					
LAM1(2,J),J=1,30										
.00	.00	.00	.00	.00	.01	.98	1.57	1.69	1.65	
.01	.98	1.53	1.77	1.67	.01	1.00	1.57	1.70	1.68	
.01	.98	1.53	1.68	1.54	.01	.94	1.04	.83	.47	
LAM1(3,J),J=1,48										
.00	.00	.00	.00	.00	.00	.00	.00	.01	.90	
1.49	1.65	1.96	2.04	2.04	1.96	.01	1.00	1.47	1.79	
1.94	1.81	2.00	1.96	.01	1.07	1.47	1.74	1.83	1.92	
1.89	1.86	.01	1.08	1.38	1.57	1.65	1.68	1.69	1.64	
.01	1.02	.97	.93	.85	.79	.71	.53			
LAM1(4,J),J=1,42										
.00	.00	.00	.00	.00	.00	.00	.01	1.10	1.49	
1.77	1.96	2.04	1.77	.01	1.06	1.41	1.67	1.83	1.96	
1.89	.01	1.00	1.31	1.55	1.72	1.89	1.79	.01	.95	
1.22	1.41	1.43	1.61	1.8	.01	.88	.97	1.01	1.01	
.90	.75									
LAM1(5,J),J=1,42										
.0	.0	.0	.0	.0	.0	.0	.01	.27	.94	
1.57	1.65	1.81	1.65	.01	.27	.98	1.57	1.67	1.77	
1.65	.01	.27	.98	1.53	1.65	1.64	1.62	.01	.27	
1.00	1.45	1.49	1.49	1.49	.01	.27	1.02	.94	.93	
.92	.93									
LAM1(6,J),J=1,60										
.0	.0	.0	.0	.0	.0	.0	.0	.0	.0	
.01	.27	.53	.78	1.16	1.69	1.85	1.77	1.73	1.57	
.01	.27	.53	.78	1.16	1.73	1.77	1.77	1.71	1.57	
.01	.27	.53	.78	1.11	1.66	1.70	1.70	1.61	1.53	
.01	.27	.53	.78	1.06	1.47	1.51	1.51	1.49	1.42	
.01	.27	.53	.78	.99	.88	.88	.93	.94	1.02	
LAM1(7,J),J=1,66										
.0	.0	.0	.0	.0	.0	.0	.0	.0	.0	
.0	.01	.27	.53	.78	1.14	1.45	1.65	1.85	1.92	
1.96	1.77	.01	.27	.53	.78	1.12	1.45	1.65	1.81	
1.83	1.85	1.71	.01	.27	.53	.78	1.11	1.40	1.61	

1.74	1.75	1.72	1.62	.01	.27	.53	.78	1.10	1.38
1.53	1.58	1.55	1.52	1.38	.01	.27	.53	.78	1.08
1.18	1.05	.94	.86	.86	.86				
LAM1 (8,J),J=1,66									
.0	.0	.0	.0	.0	.0	.0	.0	.0	.0
.0	.01	.27	.53	.78	1.10	1.57	1.89	2.28	2.63
2.63	2.16	.01	.27	.53	.78	1.10	1.16	1.94	2.26
2.43	2.45	1.96	.01	.27	.53	.78	1.09	1.48	1.89
2.21	2.16	2.12	1.86	.01	.27	.53	.78	1.06	1.47
1.87	2.10	1.77	1.73	1.51	.01	.27	.53	.78	1.02
1.41	1.76	1.32	1.02	.94	.85				
LAM1 (9,J),J=1,72									
.0	.0	.0	.0	.0	.0	.0	.0	.0	.0
.0	.0	.01	.27	.53	.78	.86	1.34	1.92	2.36
2.51	2.79	2.79	2.79	.01	.27	.53	.78	.98	1.45
1.94	2.32	2.69	2.75	2.79	2.67	.01	.27	.53	.78
.97	1.47	1.90	2.27	2.61	2.80	2.76	2.41	.01	.27
.53	.78	1.00	1.47	1.92	2.28	2.55	2.75	2.69	1.91
.01	.27	.53	.78	1.02	1.41	1.85	2.25	2.47	2.28
2.04	.94								
LAM1 (10,J),J=1,96									
.0	.0	.0	.0	.0	.0	.0	.0	.0	.0
.0	.0	.0	.0	.0	.0	.01	.28	.54	.76
1.02	1.27	1.47	1.70	1.92	2.10	2.28	2.43	2.58	2.83
2.98	3.28	.01	.28	.54	.76	1.02	1.27	1.47	1.70
1.92	2.10	2.28	2.43	2.58	2.83	2.98	3.28	.01	.28
.54	.76	1.02	1.27	1.47	1.70	1.92	2.10	2.28	2.43
2.58	2.83	2.98	3.28	.01	.28	.54	.76	1.02	1.27
1.47	1.70	1.92	2.10	2.28	2.43	2.58	2.83	2.98	3.28
.01	.28	.54	.76	1.02	1.27	1.47	1.70	1.92	2.10
2.28	2.43	2.58	2.83	2.98	3.28				
LAM1 (11,J),J=1,96									
.0	.0	.0	.0	.0	.0	.0	.0	.0	.0
.0	.0	.0	.0	.0	.0	.01	.27	.52	.76
1.02	1.27	1.49	1.72	1.93	2.13	2.31	2.47	2.63	2.88
3.01	3.11	.01	.27	.52	.76	1.02	1.27	1.49	1.72
1.93	2.13	2.31	2.47	2.63	2.88	3.01	3.11	.01	.27
.52	.76	1.02	1.27	1.49	1.72	1.93	2.13	2.31	2.47
2.63	2.88	3.01	3.11	.01	.27	.52	.76	1.02	1.27

1.49	1.72	1.93	2.13	2.31	2.47	2.63	2.88	3.01	3.11
.01	.27	.52	.76	1.02	1.27	1.49	1.72	1.93	2.13
2.31	2.47	2.63	2.88	3.01	3.11				
LAM1(12,J),J=1,102									
.0	.0	.0	.0	.0	.0	.0	.0	.0	.0
.0	.0	.0	.0	.0	.0	.0	.01	.28	.53
.75	1.02	1.28	1.50	1.73	1.96	2.15	2.34	2.50	2.66
2.88	3.05	3.13	3.22	.01	.28	.53	.75	1.02	1.28
1.50	1.73	1.96	2.15	2.34	2.50	2.66	2.88	3.05	3.13
3.22	.01	.28	.53	.75	1.02	1.28	1.50	1.73	1.96
2.15	2.34	2.50	2.66	2.88	3.05	3.13	3.22	.01	.28
.53	.75	1.02	1.28	1.50	1.73	1.96	2.15	2.34	2.50
2.66	2.88	3.05	3.13	3.22	.01	.28	.53	.75	1.02
1.28	1.50	1.73	1.96	2.15	2.34	2.50	2.66	2.88	3.05
3.13	3.22								
LAM1(13,J),J=1,102									
.0	.0	.0	.0	.0	.0	.0	.0	.0	.0
.0	.0	.0	.0	.0	.0	.0	.01	.28	.53
.76	1.03	1.28	1.51	1.75	1.97	2.17	2.36	2.53	2.68
2.90	3.07	3.12	3.16	.01	.28	.53	.76	1.03	1.28
1.51	1.75	1.97	2.17	2.36	2.53	2.68	2.90	3.07	3.12
3.16	.01	.28	.53	.76	1.03	1.28	1.51	1.75	1.97
2.17	2.36	2.53	2.68	2.90	3.07	3.12	3.16	.01	.28
.53	.76	1.03	1.28	1.51	1.75	1.97	2.17	2.36	2.53
2.68	2.90	3.07	3.12	3.16	.01	.28	.53	.76	1.03
1.28	1.51	1.75	1.97	2.17	2.36	2.53	2.68	2.90	3.07
3.12	3.16								
LAM1(14,J),J=1,102									
.000	.000	.000	.000	.000	.000	.000	.000	.000	.000
.000	.000	.000	.000	.000	.000	.000	.001	.002	.543
.810	1.020	1.322	1.564	1.795	2.011	2.213	2.397	2.563	2.710
2.940	3.082	3.129	3.082	.001	.002	.543	.810	1.070	1.322
1.564	1.795	2.011	2.213	2.397	2.563	2.710	2.940	3.082	3.129
3.082	.001	.002	.543	.810	1.070	1.322	1.564	1.795	2.011
2.213	2.397	2.563	2.710	2.940	3.082	3.129	3.082	.001	.002
.543	.810	1.070	1.322	1.564	1.795	2.011	2.213	2.397	2.563
2.710	2.940	3.082	3.129	3.082	.001	.002	.543	.810	1.070
1.322	1.564	1.795	2.011	2.213	2.397	2.563	2.710	2.940	3.082
3.129	3.082								

FIXED INPUT DATA FOR SHARP TANGENT OGIVES

```

NMACH(2)
  7
NXL2
  21
NFN2(I), I=1,7
  4   4   5   5   5   5   5
NLAM2(I), I=1,7
  84  84  105  105  105  105  105
MACH(2,I), I=1,7
  .80  1.00  2.00  3.00  4.25  5.05  15.00
XL2(J), J=1,21
  .00   .05   .10   .15   .20   .25   .30   .35   .40   .45
  .50   .55   .60   .65   .70   .75   .80   .85   .90   .95
  1.00
FN2(I,J), I=1,7 J=1,NFN2(I)
  0.50  1.39  3.00  6.00
  0.50  1.39  3.00  6.00
  0.50  1.39  3.00  4.00  5.00
  0.50  1.39  3.00  4.00  5.00
  0.50  1.39  3.00  4.00  5.00
  0.50  1.39  3.00  4.00  5.00
  0.5  1.0  3.0  4.0  5.0
LAM2(1,J), J=1,84
  0.00  4.15  1.95  1.25  2.58  3.83  1.78  1.13  3.41  3.62
  1.63  1.02  3.89  3.42  1.55  0.93  4.17  3.05  1.52  0.87
  4.31  2.58  1.48  0.78  4.35  2.47  1.42  0.61  4.30  2.42
  1.33  0.55  4.18  2.39  1.24  0.53  4.00  2.38  1.14  0.43
  3.77  2.37  1.04  0.35  3.50  2.33  0.93  0.28  3.19  2.20
  0.83  0.24  2.85  2.04  0.72  0.20  2.49  1.77  0.60  0.17
  2.11  1.40  0.49  0.13  1.70  1.14  0.40  0.11  1.29  0.95
  0.22  0.07  0.87  0.70  0.24  0.06  0.43  0.35  0.17  0.03
  0.00  0.14  0.14  0.01
LAM2(2,J), J=1,84
  0.00  4.10  2.03  1.33  2.94  3.77  1.80  1.14  3.89  3.47
  1.65  1.00  4.44  3.20  1.57  0.87  4.76  2.97  1.55  0.79
  4.92  2.77  1.53  0.71  4.96  2.67  1.48  0.63  4.90  2.58
  1.43  0.57  4.76  2.52  1.36  0.51  4.56  2.47  1.27  0.45
  4.30  2.42  1.19  0.40  3.99  2.37  1.07  0.34  3.64  2.33

```

0.66	0.30	3.25	2.27	0.68	0.27	2.84	2.19	0.58	0.23
2.40	2.12	0.49	0.20	1.94	2.03	0.42	0.17	1.47	1.94
0.33	0.15	0.99	1.85	0.26	0.13	0.50	1.75	0.18	0.12
0.00	1.65	0.13	0.10						
LAM2(3,J),J=1,105									
0.00	3.30	2.00	1.48	0.99	1.94	3.07	1.70	1.30	0.85
2.56	2.93	1.58	1.17	0.74	2.92	2.82	1.50	1.08	0.65
3.13	2.71	1.44	1.01	0.57	3.24	2.63	1.39	0.95	0.51
3.26	2.55	1.34	0.89	0.45	3.22	2.47	1.27	0.83	0.39
3.13	2.38	1.20	0.77	0.35	3.00	2.26	1.13	0.72	0.30
2.83	2.11	1.07	0.66	0.27	2.62	1.93	1.00	0.62	0.23
2.39	1.73	0.93	0.56	0.20	2.14	1.57	0.86	0.51	0.17
1.87	1.46	0.79	0.47	0.15	1.58	1.35	0.73	0.43	0.13
1.28	1.25	0.67	0.39	0.12	0.97	1.17	0.62	0.37	0.12
0.65	1.08	0.57	0.35	0.13	0.33	0.98	0.52	0.33	0.14
0.00	0.92	0.47	0.33	0.18					
LAM2(4,J),J=1,105									
0.00	3.07	1.87	1.50	1.11	1.59	2.92	1.73	1.40	1.06
2.11	2.76	1.62	1.31	1.01	2.41	2.65	1.53	1.23	0.97
2.58	2.57	1.43	1.17	0.92	2.67	2.48	1.34	1.10	0.87
2.69	2.41	1.26	1.03	0.83	2.65	2.33	1.18	0.98	0.78
2.58	2.22	1.11	0.92	0.75	2.47	2.10	1.04	0.87	0.72
2.33	1.97	0.98	0.82	0.68	2.16	1.82	0.92	0.77	0.63
1.97	1.57	0.85	0.72	0.60	1.76	1.32	0.78	0.67	0.56
1.54	1.17	0.73	0.63	0.53	1.30	1.06	0.67	0.57	0.49
1.05	0.95	0.62	0.53	0.45	0.80	0.87	0.56	0.48	0.42
0.54	0.77	0.51	0.44	0.38	0.27	0.68	0.45	0.40	0.35
0.00	0.60	0.40	0.36	0.32					
LAM2(5,J),J=1,105									
0.00	2.70	1.83	1.54	1.23	1.59	2.53	1.73	1.45	1.16
2.11	2.44	1.63	1.36	1.09	2.41	2.37	1.53	1.28	1.03
2.58	2.33	1.45	1.21	0.98	2.67	2.35	1.37	1.14	0.93
2.69	2.34	1.29	1.08	0.87	2.65	2.30	1.22	1.02	0.83
2.58	2.20	1.15	0.96	0.78	2.47	1.93	1.08	0.90	0.73
2.33	1.68	1.02	0.84	0.69	2.16	1.50	0.96	0.78	0.65
1.97	1.34	0.89	0.74	0.62	1.76	1.20	0.83	0.68	0.57
1.54	1.07	0.77	0.63	0.53	1.30	0.95	0.71	0.58	0.50
1.05	0.83	0.65	0.54	0.47	0.80	0.72	0.58	0.49	0.43
0.54	0.62	0.53	0.45	0.39	0.27	0.54	0.47	0.41	0.36
0.00	0.49	0.42	0.36	0.32					

LAM2(6,J),J=1,105

0.00	2.80	1.83	1.54	1.27	1.51	2.68	1.73	1.43	1.17
1.99	2.38	1.63	1.33	1.09	2.28	2.50	1.53	1.25	1.02
2.44	2.43	1.43	1.17	0.95	2.52	2.43	1.37	1.10	0.88
2.54	2.45	1.29	1.03	0.82	2.51	2.37	1.23	0.98	0.77
2.44	2.20	1.15	0.91	0.72	2.33	2.02	1.08	0.86	0.67
2.20	1.80	1.02	0.80	0.62	2.04	1.58	1.96	0.75	0.57
1.86	1.34	0.90	0.69	0.53	1.67	1.17	0.83	0.65	0.48
1.45	1.03	0.77	0.60	0.45	1.23	0.92	0.72	0.56	0.42
1.00	0.80	0.66	0.52	0.39	0.75	0.71	0.60	0.48	0.37
0.51	0.62	0.54	0.43	0.34	0.25	0.53	0.48	0.39	0.32
0.00	0.44	0.43	0.35	0.29					

LAM2(7,J),J=1,105

.000	3.004	1.920	1.493	1.215	1.856	3.091	1.834	1.423	1.156
2.455	3.127	1.747	1.352	1.097	2.802	3.120	1.658	1.280	1.038
3.004	3.077	1.568	1.208	.979	3.105	3.004	1.477	1.135	.919
3.128	2.903	1.384	1.062	.859	3.091	2.780	1.290	.988	.799
3.004	2.635	1.195	.914	.738	2.875	2.473	1.098	.839	.678
2.710	2.294	1.001	.764	.617	2.515	2.102	.904	.689	.555
2.294	1.897	.805	.613	.010	2.052	1.682	.706	.013	.007
1.791	1.458	.606	.008	.004	1.515	1.226	.011	.005	.002
1.226	.988	.006	.002	.002	.928	.746	.002	.001	0
.623	.011	.001	0	0	.003	.001	0	0	0
.116	.116	.116	.116	116					

FIXED INPUT DATA FOR SPHERES

NMACH(3)

12

MACH(3,I), I=1,12

.25 .40 .60 .80 1.00 1.20 1.47 1.90 2.70 3.40

4.63 15.00

A(I), I=1,12

2.34 2.52 2.58 2.77 3.16 2.84 2.41 2.12 1.78 1.618

1.618 1.99

FIXED INPUT DATA FOR CYLINDERS FOLLOWING TANGENT OGIVES

```

NMACH(4)
  5
NXD4
  14
NFN4(I), I=1,5
  3   3   3   3   2
NLAM4(I), I=1,5
  42  42  42  42  28
VACH(4,I), I=1,5
  3.00  4.24  5.05  6.28  15.00
XD4(J), J=1,14
  0.0   .5   1.0   1.5   2.0   2.5   3.0   3.5   4.0   4.5
  5.0   5.5   6.0   6.5
FN4(I,J), I=1,5 J=1,NFN4(I)
  3.0   5.0   7.0
  3.0   5.0   7.0
  3.0   5.0   7.0
  3.0   5.0   7.0
  3.00  5.00
LAM4(1,J), J=1,42
  .405  .270  .178  .320  .219  .148  .250  .182  .122  .198
  .152  .102  .159  .129  .085  .130  .107  .069  .100  .088
  .055  .078  .070  .042  .060  .053  .032  .048  .042  .024
  .037  .032  .020  .030  .027  .015  .025  .020  .013  .025
  .020  .013
LAM4(2,J), J=1,42
  .362  .264  .200  .308  .229  .172  .258  .195  .145  .212
  .165  .120  .175  .139  .100  .143  .117  .081  .120  .099
  .068  .101  .082  .056  .086  .070  .048  .072  .060  .040
  .062  .050  .035  .052  .042  .030  .044  .035  .026  .044
  .035  .026
LAM4(3,J), J=1,42
  .168  .132  .168  .142  .113  .139  .120  .098  .116  .102
  .083  .099  .088  .073  .083  .077  .062  .072  .067  .055
  .278  .239  .200  .239  .211  .172  .200  .184  .148  .170
  .062  .059  .048  .052  .051  .040  .046  .046  .035  .046
  .046  .035

```

LAM4(4,J),J=1,42

.320	.260	.200	.278	.228	.175	.238	.198	.152	.200
.160	.126	.145	.139	.110	.127	.119	.098	.110	.102
.087	.096	.089	.078	.084	.078	.069	.073	.069	.060
.063	.060	.050	.055	.053	.042	.049	.049	.034	.049
.049	.034								

LAM4(5,J),J=1,28

.116	.116	.116	.116	.116	.116	.116	.116	.116	.116
.116	.116	.116	.116	.116	.116	.116	.116	.116	.116
.116	.116	.116	.116	.116	.116	.116	.116		

FIXED INPUT DATA FOR CYLINDERS FOLLOWING CONES

```

MACH(5)
  16
NXD5
  24
NTHN5(I),I=1,16
  8   7   8   6   8   7   8   9   8   9   8   8   4   6
  4   2
NLAM5(I),I=1,16
  192 168 192 144 192 168 192 216 192 216 192 192 96 144
  96  48
MACH(5,I),I=1,16
  .70   .80   .90   .95   1.00   1.10   1.20   1.50   1.55   2.00
  2.30   3.00   4.12   4.90   6.86   15.00
XD5(J),J=1,24
  .0   .1   .2   .3   .4   .5   .6   .7   .8   .9
  1.00  1.25  1.50  1.75  2.00  2.50  3.00  3.50  4.00  4.50
  5.00  5.50  6.00  6.50
THNS(I,J),I=1,16 J=1,NTHN5(I)
  0.0   10.0  15.0  20.0  25.0  30.0  33.0  40.0
  0.0   10.0  15.0  20.0  25.0  30.0  40.0
  0.0   10.0  15.0  20.0  25.0  30.0  33.0  40.0
  0.0   10.0  20.0  25.0  33.0  40.0
  0.0   10.0  15.0  20.0  25.0  30.0  33.0  40.0
  0.0   10.0  15.0  20.0  25.0  30.0  33.0  40.0
  0.0   10.0  15.0  20.0  25.0  30.0  33.0  35.0  40.0
  0.0   3.5   5.6   8.8  14.1  18.1  20.0  27.0
  0.0   10.0  15.0  20.0  25.0  30.0  33.0  35.0  40.0
  0.0   3.5   5.6   8.8  14.0  18.0  27.0  35.0
  0.0   3.5   4.5   5.4  10.0  18.0  27.0  35.0
  0.0   4.5   5.0  10.0
  0.0   3.5   5.0   8.8  14.5  20.0
  0.0   4.5   5.4   9.5
  0.00  20.00
LAM5(1,J),J=1,192
  .01   .39  -1.10  -2.20  -2.59  -2.67  -2.67  -2.59   .01   .31
  1.49  -1.57  -2.04  -2.47  -2.63  -2.51   .01   .27   .55   .00
  -.39   2.04  -2.43  -2.32   .01   .24   .16   2.12   2.16  -1.26
  -2.04  -1.96   .01   .16   .08   1.81   3.06   .51  -1.10  -1.49

```

.01	.14	.08	1.10	2.83	2.43	1.57	-.39	.01	.10
.06	.55	1.96	3.38	3.51	1.49	.01	.08	.04	.20
.75	3.26	4.48	2.91	.01	.07	.03	-.04	.12	2.36
4.32	3.69	.01	.05	.03	-.20	-.15	1.34	3.30	3.93
.01	.04	.03	-.27	-.16	.79	1.77	3.46	.01	.03
.03	.03	.03	.12	.27	1.69	.01	.03	.03	.03
.03	-.08	-.08	.55	.01	.03	.03	.03	.03	-.10
-.08	.14	.01	.03	.03	.03	.03	.03	-.04	.03
.01	.03	.03	.03	.03	.03	.03	.03	.01	.03
.03	.03	.03	.03	.03	.03	.01	.03	.03	.03
.03	.03	.03	.03	.01	.03	.03	.03	.03	.03
.03	.03	.01	.03	.03	.03	.03	.03	.03	.03
.01	.03	.03	.03	.03	.03	.03	.03	.01	.03
.03	.03	.03	.03	.03	.03	.01	.03	.03	.03
.03	.03	.03	.03	.01	.03	.03	.03	.03	.03
.03	.03								

LAM5(2,J),J=1,168

.01	.63	-1.45	-2.83	-3.77	-4.32	-2.47	.01	.55	1.34
-1.18	-2.28	-3.26	-2.40	.01	.47	1.18	.55	-.55	-1.81
-2.20	.01	.35	.79	2.12	1.10	.00	-1.88	.01	.24
.55	2.24	2.20	1.30	-1.41	.01	.16	.27	1.61	2.51
2.24	-.82	.01	.08	.12	1.40	2.20	2.59	.00	.01
.04	.03	.55	1.77	2.59	.79	.01	.03	.03	.24
1.41	2.28	1.63	.01	.03	.03	.06	1.10	1.88	2.28
.01	.03	.03	.03	.79	1.49	2.71	.01	.03	.03
.03	.24	.75	2.92	.01	.03	.03	.03	.08	.31
2.00	.01	.03	.03	.03	.03	.08	.24	.01	.03
.03	.03	.03	.16	1.02	.01	.03	.03	.03	.03
.03	.03	.01	.03	.03	.03	.03	.03	.03	.01
.03	.03	.03	.03	.03	.03	.01	.03	.03	.03
.03	.03	.03	.01	.03	.03	.03	.03	.03	.03
.01	.03	.03	.03	.03	.03	.03	.01	.03	.03
.03	.03	.03	.03	.01	.03	.03	.03	.03	.03
.03	.01	.03	.03	.03	.03	.03	.03		

LAM5(3,J),J=1,192

.01	.39	.31	.20	-4.56	-7.50	-1.75	-2.47	.01	.67
.79	.94	-3.22	-4.79	-1.63	-2.43	.01	.86	1.26	1.45
-1.88	-2.63	-1.41	-2.20	.01	.86	1.65	1.81	-.63	-1.02
-1.18	-1.81	.01	.71	-.86	-1.10	.55	.20	-.82	-1.26

.01	.47	1.49	-1.57	1.73	1.18	-.39	-.39	.01	.24
.86	-.31	2.83	1.88	.08	.55	.01	.02	.16	1.57
3.22	2.51	.63	1.18	.01	-.08	-.24	1.67	3.30	2.91
1.26	1.69	.01	-.14	-.31	1.69	2.98	3.06	1.88	2.04
.01	-.12	-.25	1.10	1.96	3.06	2.53	2.24	.01	-.08
-.06	.00	.47	1.73	2.83	2.43	.01	-.01	.03	-.27
-.09	.71	1.65	2.20	.01	.03	.03	-.15	-.16	.31
.77	1.41	.01	.03	.03	.03	-.12	.12	.24	.59
.01	.03	.03	.03	.03	.03	.03	.03	.01	.03
.03	.03	.03	.03	.03	.03	.01	.03	.03	.03
.03	.03	.03	.03	.01	.03	.03	.03	.03	.03
.03	.03	.01	.03	.03	.03	.03	.03	.03	.03
.01	.03	.03	.03	.03	.03	.03	.03	.01	.03
.03	.03	.03	.03	.03	.03	.01	.03	.03	.03
.03	.03	.03	.03	.01	.03	.03	.03	.03	.03
.03	.03								

LAM5(4,J),J=1,144

.01	-.39	-.20	-.24	-.28	-2.24	.01	.16	.39	.39
.43	-2.18	.01	.63	.98	1.06	1.14	-2.04	.01	.90
1.49	1.73	1.81	-1.81	.01	1.06	1.85	2.12	2.55	-1.34
.01	1.08	2.00	2.28	2.71	-.86	.01	.98	1.83	2.16
2.51	-.35	.01	.71	1.49	1.81	2.00	.24	.01	.35
1.02	1.37	1.37	.76	.01	.12	.47	.79	.86	1.34
.01	-.06	.04	.20	.51	1.77	.01	-.20	-.39	-.33
-.08	2.20	.01	-.18	-.35	-.43	-.35	2.06	.01	-.04
-.24	-.35	-.47	.98	.01	-.11	-.28	-.39	-.44	-1.63
.01	.03	-.04	-.20	-.24	.03	.01	.03	.03	.03
.03	.03	.01	.03	.03	.03	.03	.03	.01	.03
.03	.03	.03	.03	.01	.03	.03	.03	.03	.03
.01	.03	.03	.03	.03	.03	.01	.03	.03	.03
.03	.03	.01	.03	.03	.03	.03	.03	.01	.03
.03	.03	.03	.03						

LAM5(5,J),J=1,192

.01	.35	.63	.20	-.22	-.24	-.24	-.12	.01	.63
.83	.79	.59	.55	.59	.79	.01	.86	1.02	1.18
1.22	1.26	1.34	1.61	.01	1.01	1.23	1.49	1.65	1.86
1.96	2.32	.01	1.02	1.41	1.71	2.00	2.28	2.42	2.77
.01	.98	1.47	1.85	2.12	2.47	2.59	2.94	.01	.86
1.40	1.81	2.08	2.40	2.51	2.87	.01	.68	1.18	1.57

1.83	2.12	2.24	2.59	.01	.49	.90	1.20	1.49	1.79
1.89	2.16	.01	.31	.59	.88	1.10	1.37	1.45	1.67
.01	.16	.31	.59	.75	.93	.98	1.20	.01	-.18
-.14	-.08	.06	.06	.08	.20	.01	-.24	-.28	-.39
-.39	-.46	-.47	-.51	.01	-.20	-.28	-.47	-.57	-.65
-.71	-.93	.01	-.20	-.27	-.47	-.57	-.65	-.71	-.94
.01	-.13	-.20	-.39	-.49	-.59	-.67	-.94	.01	.16
.04	-.04	-.12	-.18	-.22	-.35	.01	.03	.03	.03
.03	.03	.03	.03	.01	.03	.03	.03	.03	.03
.03	.03	.01	.03	.03	.03	.03	.03	.03	.03
.01	.03	.03	.03	.03	.03	.03	.03	.01	.03
.03	.03	.03	.03	.03	.03	.01	.03	.03	.03
.03	.03	.03	.03	.01	.03	.03	.03	.03	.03
.03	.03								

LAM5(6,J),J=1,168

.01	.39	.45	.21	.08	.06	.00	.01	.50	.71
.61	.59	.63	.68	.01	.61	.90	.98	1.06	1.22
1.41	.01	.67	1.02	1.27	1.49	1.73	2.06	.01	.69
1.10	1.49	1.81	2.14	2.50	.01	.67	1.14	1.57	2.00
2.38	2.67	.01	.61	1.10	1.53	1.91	2.36	2.54	.01
.52	.98	1.37	1.67	2.12	2.07	.01	.43	.81	1.12
1.37	1.81	1.95	.01	.33	.59	.82	1.02	1.41	1.53
.01	.24	.35	.57	.62	.98	1.16	.01	.00	.00
-.03	-.12	-.06	.31	.01	-.12	-.16	-.28	-.45	-.58
-.31	.01	-.13	-.20	-.37	-.51	-.70	-.71	.01	-.14
-.20	-.37	-.51	-.65	-.71	.01	-.10	-.20	-.39	-.39
-.55	-.88	.01	.03	-.08	-.20	.04	.03	-.39	.01
.03	.03	.03	.03	.03	.03	.01	.03	.03	.03
.03	.03	.03	.01	.03	.03	.03	.03	.03	.03
.01	.03	.03	.03	.03	.03	.03	.01	.03	.03
.03	.03	.03	.03	.01	.03	.03	.03	.03	.03
.03	.01	.03	.03	.03	.03	.03	.03		

LAM5(7,J),J=1,192

.01	.16	.16	.04	-.08	-.20	-.20	-.16	.01	.35
.47	.49	.55	.63	.75	.94	.01	.51	.67	.83
1.02	1.18	1.34	1.65	.01	.59	.83	1.05	1.35	1.56
1.73	2.16	.01	.62	.90	1.18	1.57	1.77	1.96	2.37
.01	.59	.94	1.27	1.65	1.85	2.04	2.38	.01	.53
.90	1.30	1.63	1.85	2.00	2.28	.01	.43	.83	1.24

LAM5(9,J),J=1,192

.010	.188	.420	.620	.920	1.180	1.300	1.590	.010	.180
.385	.580	.840	1.040	1.200	1.450	.010	.170	.348	.540
.760	.910	1.100	1.300	.010	.160	.320	.500	.685	.800
.990	1.160	.010	.153	.295	.466	.615	.710	.880	1.028
.010	.145	.270	.428	.545	.620	.770	.900	.010	.135
.250	.398	.492	.550	.668	.790	.010	.128	.233	.360
.417	.480	.570	.680	.010	.122	.218	.325	.385	.428
.485	.585	.010	.115	.202	.295	.338	.378	.415	.500
.010	.110	.190	.260	.292	.327	.360	.408	.010	.093
.162	.205	.215	.240	.266	.295	.010	.085	.138	.160
.172	.192	.212	.238	.010	.072	.119	.133	.145	.160
.180	.200	.010	.060	.100	.115	.126	.140	.155	.170
.010	.045	.075	.090	.098	.110	.122	.130	.010	.032
.055	.068	.072	.087	.098	.105	.010	.022	.040	.051
.055	.068	.075	.085	.010	.015	.032	.040	.042	.052
.061	.068	.010	.010	.022	.030	.031	.041	.050	.055
.010	.008	.018	.023	.023	.032	.040	.043	.010	.010
.016	.020	.022	.030	.035	.037	.010	.005	.008	.012
.012	.018	.021	.025	.010	.005	.008	.012	.012	.018
.021	.025								

LAM5(10,J),J=1,216

.01	.63	.75	.80	.67	.46	.31	.21	.00	.01
.63	.75	.80	.78	.66	.54	.48	.33	.01	.61
.75	.80	.83	.79	.72	.69	.62	.01	.60	.73
.79	.86	.86	.85	.84	.80	.01	.57	.71	.79
.86	.92	.94	.94	.96	.01	.55	.68	.77	.86
.94	.98	1.01	1.05	.01	.52	.66	.74	.84	.94
1.01	1.04	1.11	.01	.50	.63	.71	.81	.91	.99
1.04	1.14	.01	.54	.59	.68	.77	.87	.95	1.01
1.13	.01	.43	.55	.64	.73	.83	.90	.96	1.09
.01	.39	.51	.60	.68	.61	.85	.89	1.01	.01
.30	.42	.49	.57	.63	.70	.73	.78	.01	.22
.31	.39	.46	.51	.55	.57	.57	.01	.15	.23
.28	.35	.39	.41	.42	.41	.01	.09	.15	.19
.25	.28	.29	.28	.28	.01	.03	.04	.06	.07
.10	.10	.10	.09	.01	.03	.03	.03	-.05	-.02
.03	.03	.03	.01	.03	.03	.03	-.02	.03	.03
.03	.03	.01	.03	.03	.03	.03	.03	.03	.03

.03	.01	.03	.03	.03	.03	.03	.03	.03	.03
.01	.03	.03	.03	.03	.03	.03	.03	.03	.01
.03	.03	.03	.03	.03	.03	.03	.03	.01	.03
.03	.03	.03	.03	.03	.03	.03	.01	.03	.03
.03	.03	.03	.03	.03	.03				
LAM5(11,J),J=1,192									
.010	.285	.420	.562	.700	.800	.930	.953	.010	.272
.398	.530	.657	.738	.897	.918	.010	.263	.373	.498
.618	.680	.860	.825	.010	.252	.350	.465	.584	.630
.820	.840	.010	.240	.330	.437	.550	.595	.788	.806
.010	.228	.315	.420	.524	.560	.750	.770	.010	.219
.295	.392	.503	.530	.718	.738	.010	.210	.280	.372
.480	.502	.681	.700	.010	.201	.268	.352	.462	.481
.650	.670	.010	.192	.255	.338	.448	.462	.615	.635
.010	.184	.243	.320	.430	.446	.580	.600	.010	.168
.218	.290	.396	.410	.498	.520	.010	.150	.199	.262
.365	.380	.428	.455	.010	.133	.179	.239	.340	.350
.382	.406	.010	.121	.160	.215	.315	.330	.348	.365
.010	.100	.128	.180	.271	.284	.298	.305	.010	.080
.103	.150	.232	.242	.252	.259	.010	.065	.080	.122
.200	.205	.215	.217	.010	.052	.065	.100	.165	.170
.179	.180	.010	.040	.050	.079	.133	.140	.142	.147
.010	.028	.035	.060	.108	.110	.113	.115	.010	.020
.028	.042	.078	.080	.080	.082	.010	.010	.018	.032
.052	.053	.054	.055	.010	.010	.018	.032	.052	.053
.054	.055								
LAM5(12,J),J=1,192									
.010	.318	.422	.530	.660	.752	.890	.941	.010	.295
.392	.491	.630	.720	.860	.908	.010	.270	.363	.458
.600	.690	.831	.879	.010	.248	.330	.425	.572	.660
.800	.841	.010	.226	.312	.400	.542	.623	.766	.813
.010	.210	.288	.370	.517	.595	.740	.780	.010	.195
.268	.348	.492	.568	.712	.750	.010	.180	.250	.223
.462	.540	.681	.720	.010	.168	.233	.306	.440	.513
.658	.690	.010	.157	.217	.289	.417	.484	.623	.660
.010	.148	.202	.271	.395	.461	.600	.630	.010	.128
.172	.238	.340	.406	.539	.570	.010	.110	.150	.208
.291	.358	.478	.502	.010	.095	.130	.187	.252	.312
.422	.445	.010	.085	.110	.160	.216	.272	.371	.391

.010	.065	.081	.126	.160	.210	.284	.300	.010	.050
.060	.096	.121	.162	.213	.230	.010	.035	.047	.070
.097	.125	.163	.178	.010	.026	.033	.052	.076	.095
.130	.140	.010	.018	.027	.039	.060	.073	.102	.110
.010	.013	.020	.032	.051	.059	.081	.088	.010	.010
.018	.025	.040	.048	.065	.070	.010	.012	.018	.021
.038	.042	.052	.057	.010	.012	.018	.021	.038	.042
.052	.057								

LAM5(13,J),J=1,96

.010	.327	.380	.536	.010	.310	.360	.513	.010	.296
.344	.492	.010	.282	.328	.470	.010	.269	.312	.450
.010	.258	.298	.430	.010	.247	.283	.413	.010	.237
.270	.393	.010	.227	.257	.375	.010	.218	.244	.359
.010	.209	.233	.342	.010	.190	.208	.301	.010	.174
.178	.267	.010	.157	.110	.236	.010	.145	.154	.208
.010	.122	.129	.166	.010	.100	.107	.137	.010	.083
.090	.116	.010	.068	.074	.100	.010	.055	.060	.087
.010	.044	.047	.076	.010	.035	.038	.067	.010	.028
.030	.060	.010	.028	.030	.060				

LAM5(14,J),J=1,144

.010	.358	.470	.508	.600	.799	.010	.330	.428	.470
.547	.739	.010	.309	.397	.436	.500	.681	.010	.290
.370	.408	.465	.620	.010	.273	.347	.380	.430	.570
.010	.260	.326	.358	.400	.525	.010	.246	.307	.339
.375	.480	.010	.236	.290	.320	.352	.440	.010	.226
.276	.304	.333	.405	.010	.217	.260	.290	.317	.373
.010	.209	.250	.277	.300	.345	.010	.190	.225	.246
.266	.284	.010	.177	.207	.223	.239	.248	.010	.164
.192	.205	.216	.224	.010	.153	.178	.189	.199	.204
.010	.136	.158	.166	.170	.176	.010	.123	.143	.147
.151	.155	.010	.113	.130	.134	.137	.140	.010	.106
.122	.124	.127	.130	.010	.100	.115	.117	.119	.122
.010	.096	.108	.110	.113	.116	.010	.092	.102	.106
.109	.112	.010	.090	.100	.103	.106	.109	.010	.090
.100	.103	.106	.109						

LAM5(15,J),J=1,96

.010	.256	.428	.618	.010	.237	.390	.535	.010	.222
.355	.477	.010	.210	.328	.430	.010	.200	.302	.395
.010	.191	.282	.360	.010	.183	.266	.335	.010	.176

.249	.210	.010	.170	.235	.290	.010	.163	.222	.273
.010	.157	.211	.258	.010	.145	.192	.227	.010	.135
.176	.206	.010	.126	.160	.189	.010	.118	.149	.174
.010	.104	.128	.152	.010	.095	.114	.135	.010	.086
.102	.122	.010	.080	.094	.113	.010	.075	.088	.105
.010	.072	.083	.100	.010	.069	.079	.095	.010	.067
.077	.092	.010	.067	.077	.092				
LAM ⁵ (16,J), J=1,48									
.116	.116	.116	.116	.116	.116	.116	.116	.116	.116
.116	.116	.116	.116	.116	.116	.116	.116	.116	.116
.116	.116	.116	.116	.116	.116	.116	.116	.116	.116
.116	.116	.116	.116	.116	.116	.116	.116	.116	.116
.116	.116	.116	.116	.116	.116	.116	.116	.116	.116

FIXED INPUT DATA FOR FRUSTUMS FOLLOWING CONE CYLINDERS

```

NMACH(6)
      8
NXD6
      18
NTHN6(I),I=1,8
      3      3      3      3      3      3      3      2
NTHF6(I,J),I=1,8 J=1,NTHN6(I)
      4      4      4
      4      4      4
      4      4      4
      4      4      2
      2      4      2
      2      4      2
      2      4      2
      4      4
NFA6(1,J,K),J=1,3 K=1,NTHF6(1,J)
      4      4      4      3
      4      4      4      4
      4      4      4      4
NFA6(2,J,K),J=1,3 K=1,NTHF6(2,J)
      4      4      4      3
      4      4      4      4
      4      4      4      4
NFA6(3,J,K),J=1,3 K=1,NTHF6(3,J)
      4      4      4      3
      4      4      4      4
      4      4      4      4
NFA6(4,J,K),J=1,3 K=1,NTHF6(4,J)
      3      3      3      2
      4      4      4      4
      3      3
NFA6(5,J,K),J=1,3 K=1,NTHF6(5,J)
      3      2
      4      4      4      4
      3      3
NFA6(6,J,K),J=1,3 K=1,NTHF6(6,J)
      3      2
      4      4      4      4
      3      3

```

```

NFA6(7,J,K),J=1,3 K=1,NTHF6(7,J)
  3   2
  4   4   4   4
  3   3
NFA6(8,J,K),J=1,2 K=1,NTHF6(8,J)
  4   4   4   4
  4   4   4   4
NLAM6(1,J,K),J=1,3 K=1,NTHF6(1,J)
  72  72  72  54
  72  72  72  72
  72  72  72  72
NLAM6(2,J,K),J=1,3 K=1,NTHF6(2,J)
  72  72  72  54
  72  72  72  72
  72  72  72  72
NLAM6(3,J,K),J=1,3 K=1,NTHF6(3,J)
  72  72  72  54
  72  72  72  72
  72  72  72  72
NLAM6(4,J,K),J=1,3 K=1,NTHF6(4,J)
  54  54  54  36
  72  72  72  72
  54  54
NLAM6(5,J,K),J=1,3 K=1,NTHF6(5,J)
  54  36
  72  72  72  72
  54  54
NLAM6(6,J,K),J=1,3 K=1,NTHF6(6,J)
  54  36
  72  72  72  72
  54  54
NLAM6(7,J,K),J=1,3 K=1,NTHF6(7,J)
  54  36
  72  72  72  72
  54  54
NLAM6(8,J,K),J=1,2 K=1,NTHF6(8,J)
  72  72  72  72
  72  72  72  72

```

NTOTL6(I,J),I=1,8 J=1,NTHN6(I)

270 288 288
270 288 288
270 288 288
198 288 108
90 288 108
90 288 108
90 288 108
288 288

NTOTFA(I,J),I=1,8 J=1,NTHN6(I)

15 16 16
15 16 16
15 16 16
11 16 6
5 16 6
5 16 6
5 16 6
16 16

MACH(6,I),I=1,8

.80 .90 1.20 1.50 2.18 2.81 4.04 15.00

XD6(J),J=1,18

0.0 .2 .4 .6 .8 1.0 1.25 1.50 2.00 2.50
3.00 3.50 4.00 4.50 5.00 5.50 6.00 6.50

THN6(I,J),I=1,8 J=1,NTHN6(I)

15.0 22.5 30.0
15.0 22.5 30.0
15.0 22.5 30.0
15.0 22.5 30.0
15.0 22.5 30.0
15.0 22.5 30.0
15.0 22.5 30.0
15.00 22.50

THF6(1,J,K),J=1,3 K=1,NTHF6(1,J)

5.0 10.0 15.0 20.0
5.0 10.0 15.0 20.0
5.0 10.0 15.0 20.0

THF6(2,J,K),J=1,3 K=1,NTHF6(2,J)

5.0 10.0 15.0 20.0
5.0 10.0 15.0 20.0
5.0 10.0 15.0 20.0


```

THF6(3,J,K),J=1,3 K=1,NTHF6(3,J)
  5.0  10.0  15.0  20.0
  5.0  10.0  15.0  20.0
  5.0  10.0  15.0  20.0
THF6(4,J,K),J=1,3 K=1,NTHF6(4,J)
  5.0  10.0  15.0  20.0
  5.0  10.0  15.0  20.0
  5.0  20.0
THF6(5,J,K),J=1,3 K=1,NTHF6(5,J)
  5.0  20.0
  5.0  10.0  15.0  20.0
  5.0  20.0
THF6(6,J,K),J=1,3 K=1,NTHF6(6,J)
  5.0  20.0
  5.0  10.0  15.0  20.0
  5.0  20.0
THF6(7,J,K),J=1,3 K=1,NTHF6(7,J)
  5.0  20.0
  5.0  10.0  15.0  20.0
  5.0  20.0
THF6(8,J,K),J=1,2 K=1,NTHF6(8,J)
  5.00  10.00  15.00  20.00
  5.00  10.00  15.00  20.00
FA6(1,J,K),J=1,3 K=1,NTOTFA(1,J)
  0.0  1.0  2.0  4.0  0.0  1.0  2.0  4.0  0.0  1.0
  2.0  4.0  1.0  2.0  4.0
  0.0  1.0  2.0  4.0  0.0  1.0  2.0  4.0  0.0  1.0
  2.0  4.0  0.0  1.0  2.0  4.0
  0.0  1.0  2.0  4.0  0.0  1.0  2.0  4.0  0.0  1.0
  2.0  4.0  0.0  1.0  2.0  4.0
FA6(2,J,K),J=1,3 K=1,NTOTFA(2,J)
  0.0  1.0  2.0  4.0  0.0  1.0  2.0  4.0  0.0  1.0
  2.0  4.0  1.0  2.0  4.0
  0.0  1.0  2.0  4.0  0.0  1.0  2.0  4.0  0.0  1.0
  2.0  4.0  0.0  1.0  2.0  4.0
  0.0  1.0  2.0  4.0  0.0  1.0  2.0  4.0  0.0  1.0
  2.0  4.0  0.0  1.0  2.0  4.0
FA6(3,J,K),J=1,3 K=1,NTOTFA(3,J)
  0.0  1.0  2.0  4.0  0.0  1.0  2.0  4.0  0.0  1.0
  2.0  4.0  1.0  2.0  4.0

```

0.0	1.0	2.0	4.0	0.0	1.0	2.0	4.0	0.0	1.0				
2.0	4.0	0.0	1.0	2.0	4.0								
0.0	1.0	2.0	4.0	0.0	1.0	2.0	4.0	0.0	1.0				
2.0	4.0	0.0	1.0	2.0	4.0								
FA6(4,J,K),J=1,3 K=1,NTOTFA(4,J)													
0.0	1.0	4.0	0.0	1.0	4.0	0.0	1.0	4.0	1.0				
4.0													
0.0	1.0	2.0	4.0	0.0	1.0	2.0	4.0	0.0	1.0				
2.0	4.0	0.0	1.0	2.0	4.0								
0.0	1.0	4.0	0.0	1.0	4.0								
FA6(5,J,K),J=1,3 K=1,NTOTFA(5,J)													
0.0	1.0	4.0	1.0	4.0									
0.0	1.0	2.0	4.0	0.0	1.0	2.0	4.0	0.0	1.0				
2.0	4.0	0.0	1.0	2.0	4.0								
0.0	1.0	4.0	0.0	1.0	4.0								
FA6(6,J,K),J=1,3 K=1,NTOTFA(6,J)													
0.0	1.0	4.0	1.0	4.0									
0.0	1.0	2.0	4.0	0.0	1.0	2.0	4.0	0.0	1.0				
2.0	4.0	0.0	1.0	2.0	4.0								
0.0	1.0	4.0	0.0	1.0	4.0								
FA6(7,J,K),J=1,3 K=1,NTOTFA(7,J)													
0.0	1.0	4.0	1.0	4.0									
0.0	1.0	2.0	4.0	0.0	1.0	2.0	4.0	0.0	1.0				
2.0	4.0	0.0	1.0	2.0	4.0								
0.0	1.0	4.0	0.0	1.0	4.0								
FA6(8,J,K),J=1,2 K=1,NTOTFA(8,J)													
0.0	1.0	2.0	4.0	0.0	1.0	2.0	4.0	0.0	1.0				
2.0	4.0	0.0	1.0	2.0	4.0								
0.0	1.0	2.0	4.0	0.0	1.0	2.0	4.0	0.0	1.0				
2.0	4.0	0.0	1.0	2.0	4.0								
K1(1,J,K),J=1,3 K=1,NTOTFA(1,J)													
0	0	1	1	0	0	1	1	0	0	0	0	0	1
0													
0	0	1	1	0	0	0	1	0	0	0	0	0	0
0	0												
0	0	0	0	0	0	0	0	0	0	0	0	0	0
0	0												
K1(2,J,K),J=1,3 K=1,NTOTFA(2,J)													
0	0	0	0	0	0	0	0	0	0	0	0	0	0
0													

0	0	0	0	0	0	0	0	0	0	0	0	0	0
0	0												
0	0	0	0	0	0	0	0	0	0	0	0	0	0
0	0												
K1(3,J,K),J=1,3 K=1,NTOTFA(3,J)													
0	0	0	0	0	0	0	0	0	0	0	0	0	0
0													
0	0	0	0	0	0	0	0	0	0	0	0	0	0
0	0												
0	0	0	0	0	0	0	0	0	0	0	0	0	0
0	0												
K1(4,J,K),J=1,3 K=1,NTOTFA(4,J)													
0	1	1	0	1	1	0	1	1	1	1			
0	1	1	1	0	1	1	1	0	1	1	1	0	1
1	1												
0	1	1	0	1	1								
K1(5,J,K),J=1,3 K=1,NTOTFA(5,J)													
0	1	1	1	1									
0	1	1	1	0	1	1	1	0	1	1	1	0	1
1	1												
0	1	1	0	1	1								
K1(6,J,K),J=1,3 K=1,NTOTFA(6,J)													
0	1	1	1	1									
0	1	1	1	0	1	1	1	0	1	1	1	0	1
1	1												
0	1	1	0	1	1								
K1(7,J,K),J=1,3 K=1,NTOTFA(7,J)													
0	1	1	1	1									
0	1	1	1	0	1	1	1	0	1	1	1	0	1
1	1												
0	1	1	0	1	1								
K1(8,J,K),J=1,2 K=1,NTOTFA(8,J)													
0	1	1	1	0	1	1	1	0	1	1	1	0	1
1	1												
0	1	1	1	0	1	1	1	0	1	1	1	0	1
1	1												
LAM6(1,1,K),K=1,270													
1.10	.23	.50	1.00	.97	.28	.53	.74	.87	.34				
.53	.63	.79	.38	.50	.57	.74	.42	.47	.53				
.69	.43	.46	.52	.64	.44	.47	.53	.62	.48				

.51	.54	.58	.60	.57	.59	.56	.62	.60	.60
.56	.63	.60	.58	.56	.63	.57	.58	.56	.59
.52	.58	.56	.59	.52	.58	.56	.59	.52	.58
.56	.59	.52	.58	.56	.59	.52	.58	.56	.59
.52	.58	1.33	.38	1.03	1.50	1.29	.51	1.10	1.33
1.24	.63	1.12	1.22	1.23	.73	1.13	1.13	1.20	.80
1.12	1.10	1.18	.84	1.12	1.08	1.14	.88	1.17	1.06
1.13	.94	1.22	1.07	1.10	1.12	1.26	1.14	1.08	1.24
1.24	1.23	1.10	1.27	1.20	1.23	1.10	1.27	1.18	1.23
1.10	1.22	1.20	1.23	1.10	1.22	1.20	1.23	1.10	1.22
1.20	1.23	1.10	1.22	1.20	1.23	1.10	1.22	1.20	1.23
1.10	1.22	1.20	1.23	1.41	.47	1.07	1.60	1.41	.63
1.13	1.46	1.41	.77	1.18	1.36	1.41	.88	1.21	1.30
1.41	.96	1.22	1.27	1.41	1.03	1.22	1.25	1.41	1.12
1.25	1.23	1.41	1.18	1.28	1.23	1.41	1.26	1.38	1.31
1.41	1.34	1.39	1.36	1.41	1.36	1.34	1.38	1.41	1.36
1.31	1.38	1.41	1.36	1.33	1.38	1.41	1.36	1.33	1.38
1.41	1.36	1.33	1.38	1.41	1.36	1.33	1.38	1.41	1.36
1.33	1.38	1.41	1.36	1.33	1.38	.62	1.10	1.70	.81
1.20	1.60	.96	1.25	1.52	1.08	1.27	1.46	1.19	1.28
1.43	1.26	1.30	1.42	1.34	1.36	1.41	1.49	1.42	1.42
1.46	1.50	1.46	1.50	1.51	1.50	1.50	1.49	1.51	1.50
1.49	1.51	1.50	1.49	1.51	1.50	1.49	1.51	1.50	1.49
1.51	1.50	1.49	1.51	1.50	1.49	1.51	1.50	1.49	1.51
LAM6(1,2,K),K=1,288									
1.20	.06	.95	1.10	1.06	.22	.66	.78	.94	.33
.53	.64	.86	.41	.48	.57	.78	.47	.52	.53
.73	.52	.56	.52	.68	.56	.61	.53	.64	.60
.62	.56	.59	.60	.62	.60	.54	.60	.61	.60
.52	.60	.63	.54	.52	.60	.63	.54	.52	.60
.63	.54	.52	.60	.63	.54	.52	.60	.63	.54
.52	.60	.63	.54	.52	.60	.63	.54	.52	.60
.63	.54	1.44	.20	1.40	1.63	1.37	.54	1.23	1.30
1.29	.72	1.13	1.13	1.24	.84	1.10	1.04	1.21	.92
1.08	1.00	1.18	.96	1.08	1.00	1.14	.98	1.09	1.01
1.13	.99	1.10	1.03	1.10	1.00	1.15	1.10	1.08	1.00
1.19	1.17	1.10	1.02	1.20	1.20	1.10	1.02	1.20	1.20

1.10	1.02	1.20	1.20	1.10	1.02	1.20	1.20	1.10	1.02
1.20	1.20	1.10	1.02	1.20	1.20	1.10	1.02	1.20	1.20
1.10	1.02	1.20	1.20	1.67	.31	1.56	1.80	1.62	.77
1.43	1.50	1.57	.98	1.33	1.36	1.54	1.10	1.28	1.27
1.51	1.18	1.26	1.22	1.48	1.23	1.27	1.20	1.45	1.25
1.28	1.20	1.43	1.27	1.32	1.22	1.39	1.27	1.37	1.31
1.38	1.27	1.40	1.37	1.40	1.27	1.40	1.40	1.40	1.27
1.40	1.40	1.40	1.27	1.40	1.40	1.40	1.27	1.40	1.40
1.40	1.27	1.40	1.40	1.40	1.27	1.40	1.40	1.40	1.27
1.40	1.40	1.40	1.27	1.40	1.40	2.00	.51	1.72	1.94
1.97	1.03	1.59	1.67	1.94	1.27	1.51	1.53	1.91	1.38
1.47	1.46	1.89	1.46	1.47	1.42	1.87	1.50	1.48	1.40
1.84	1.53	1.50	1.42	1.83	1.54	1.53	1.43	1.81	1.56
1.58	1.51	1.80	1.57	1.60	1.57	1.80	1.58	1.56	1.60
1.80	1.58	1.56	1.60	1.80	1.58	1.56	1.60	1.80	1.58
1.56	1.60	1.80	1.58	1.56	1.60	1.80	1.58	1.56	1.60
1.80	1.58	1.56	1.60	1.80	1.58	1.56	1.60		

LAM6(1,3,K),K=1,288

1.52	0.00	.91	1.02	1.22	.29	.71	.83	1.16	.38
.61	.73	.94	.44	.56	.67	.87	.47	.54	.64
.83	.50	.54	.63	.80	.53	.54	.63	.80	.57
.56	.63	.83	.60	.59	.64	.94	.58	.60	.63
1.06	.56	.57	.57	1.06	.56	.57	.57	1.06	.56
.57	.57	1.06	.56	.57	.57	1.06	.56	.57	.57
1.06	.56	.57	.57	1.06	.56	.57	.57	1.06	.56
.57	.57	1.86	.00	1.34	1.48	1.67	.81	1.19	1.29
1.54	.99	1.10	1.18	1.44	1.06	1.05	1.13	1.37	1.07
1.03	1.10	1.31	1.09	1.04	1.10	1.25	1.12	1.07	1.10
1.22	1.13	1.10	1.10	1.19	1.19	1.14	1.10	1.22	1.21
1.19	1.10	1.25	1.17	1.18	1.04	1.25	1.17	1.18	1.04
1.25	1.17	1.18	1.04	1.25	1.17	1.18	1.04	1.25	1.17
1.18	1.04	1.25	1.17	1.18	1.04	1.25	1.17	1.18	1.04
1.25	1.17	1.18	1.04	2.11	.00	1.50	1.66	1.96	.95
1.37	1.52	1.84	1.14	1.28	1.43	1.74	1.25	1.23	1.36
1.67	1.32	1.21	1.33	1.62	1.35	1.21	1.32	1.56	1.38
1.23	1.33	1.53	1.40	1.28	1.36	1.48	1.51	1.36	1.38
1.45	1.40	1.40	1.37	1.45	1.40	1.42	1.31	1.45	1.40
1.42	1.31	1.45	1.40	1.42	1.31	1.45	1.40	1.42	1.31
1.45	1.40	1.42	1.31	1.45	1.40	1.42	1.31	1.45	1.40
1.42	1.31	1.45	1.40	1.42	1.31	2.50	.00	1.63	1.83

2.32	1.08	1.48	1.70	2.18	1.34	1.42	1.63	2.09	1.47
1.39	1.59	2.01	1.53	1.39	1.58	1.94	1.57	1.41	1.58
1.87	1.63	1.44	1.60	1.83	1.54	1.48	1.62	1.73	1.66
1.56	1.64	1.66	1.66	1.64	1.65	1.60	1.66	1.66	1.60
1.60	1.66	1.66	1.60	1.60	1.66	1.66	1.60	1.60	1.66
1.66	1.60	1.60	1.66	1.66	1.60	1.60	1.66	1.66	1.60
1.60	1.66	1.66	1.60	1.60	1.66	1.66	1.60		

LAM6(2,1,K),K=1,270

.99	.21	.45	.90	.87	.25	.48	.67	.78	.31
.48	.57	.71	.34	.45	.51	.67	.38	.42	.48
.62	.39	.41	.47	.58	.40	.42	.48	.56	.43
.46	.49	.52	.54	.51	.53	.50	.56	.54	.54
.50	.57	.54	.52	.50	.57	.51	.52	.50	.53
.47	.52	.50	.53	.47	.52	.50	.53	.47	.52
.50	.53	.47	.52	.50	.53	.47	.52	.50	.53
.47	.52	1.20	.34	.93	1.35	1.16	.46	.99	1.20
1.12	.57	1.01	1.10	1.10	.66	1.02	1.02	1.08	.72
1.01	.99	1.06	.76	1.01	.97	1.03	.79	1.05	.95
1.02	.85	1.10	.96	.99	1.01	1.13	1.03	.97	1.12
1.12	1.11	.99	1.14	1.08	1.11	.99	1.14	1.06	1.11
.99	1.10	1.08	1.11	.99	1.10	1.08	1.11	.99	1.10
1.08	1.11	.99	1.10	1.08	1.11	.99	1.10	1.08	1.11
.99	1.11	1.08	1.14	1.27	.42	.96	1.44	1.27	.57
1.02	1.31	1.27	.69	1.06	1.22	1.27	.79	1.09	1.17
1.27	.86	1.10	1.14	1.27	.93	1.10	1.13	1.27	1.01
1.13	1.11	1.27	1.06	1.15	1.11	1.27	1.13	1.24	1.18
1.27	1.21	1.25	1.22	1.27	1.25	1.21	1.24	1.27	1.22
1.18	1.24	1.27	1.22	1.20	1.24	1.27	1.22	1.20	1.24
1.27	1.22	1.20	1.24	1.27	1.22	1.20	1.24	1.27	1.22
1.20	1.24	1.27	1.22	1.20	1.24	.56	.99	1.53	.73
1.08	1.44	.86	1.13	1.37	.97	1.14	1.31	1.07	1.15
1.29	1.13	1.17	1.28	1.21	1.22	1.27	1.34	1.28	1.28
1.31	1.35	1.31	1.35	1.36	1.35	1.35	1.34	1.36	1.35
1.34	1.36	1.35	1.34	1.36	1.35	1.34	1.36	1.35	1.34
1.36	1.35	1.34	1.36	1.35	1.34	1.36	1.35	1.34	1.36

LAM6(2,2,K),K=1,288

1.08	.05	.86	.99	.94	.20	.59	.70	.85	.30
.48	.58	.77	.37	.43	.51	.70	.42	.47	.48
.66	.47	.50	.47	.61	.50	.55	.48	.58	.54
.56	.50	.53	.54	.56	.54	.49	.54	.55	.54

.47	.54	.57	.49	.47	.54	.57	.49	.47	.54
.57	.49	.47	.54	.57	.49	.47	.54	.57	.49
.47	.54	.57	.49	.47	.54	.57	.49	.47	.54
.57	.49	1.30	.18	1.26	1.47	1.23	.49	1.11	1.17
1.16	.65	1.02	1.02	1.12	.76	.99	.94	1.09	.83
.97	.90	1.06	.86	.97	.90	1.03	.88	.98	.91
1.02	.89	.99	.93	.99	.90	1.04	.99	.97	.90
1.07	1.05	.99	.92	1.08	1.08	.99	.92	1.08	1.08
.99	.92	1.08	1.08	.99	.92	1.08	1.08	.99	.92
1.08	1.08	.99	.92	1.08	1.08	.99	.92	1.08	1.08
.99	.92	1.08	1.08	1.50	.28	1.40	1.62	1.46	.69
1.29	1.35	1.41	.88	1.20	1.22	1.39	.99	1.15	1.14
1.36	1.06	1.13	1.10	1.33	1.11	1.14	1.08	1.31	1.13
1.15	1.08	1.29	1.14	1.19	1.10	1.25	1.14	1.23	1.18
1.24	1.14	1.26	1.23	1.26	1.14	1.26	1.26	1.26	1.14
1.26	1.26	1.26	1.14	1.26	1.26	1.26	1.14	1.26	1.26
1.26	1.14	1.26	1.26	1.26	1.14	1.26	1.26	1.26	1.14
1.26	1.26	1.26	1.14	1.26	1.26	1.80	.46	1.55	1.75
1.77	.93	1.43	1.50	1.75	1.14	1.36	1.38	1.72	1.24
1.32	1.31	1.70	1.31	1.32	1.28	1.68	1.35	1.33	1.26
1.66	1.38	1.35	1.28	1.65	1.39	1.38	1.29	1.63	1.40
1.42	1.36	1.62	1.41	1.44	1.41	1.62	1.42	1.40	1.44
1.62	1.42	1.40	1.44	1.62	1.42	1.40	1.44	1.62	1.42
1.40	1.44	1.62	1.42	1.40	1.44	1.62	1.42	1.40	1.44
1.62	1.42	1.40	1.44	1.62	1.42	1.40	1.44	1.40	1.44
LAM6(2,3,K),K=1,288									
1.37	.00	.82	.92	1.10	.26	.64	.75	1.04	.34
.55	.66	.85	.40	.50	.60	.78	.42	.49	.58
.75	.45	.49	.57	.72	.48	.49	.57	.72	.51
.50	.57	.75	.54	.53	.58	.85	.52	.54	.57
.95	.50	.51	.51	.95	.50	.51	.51	.95	.50
.51	.51	.95	.50	.51	.51	.95	.50	.51	.51
.95	.50	.51	.51	.95	.50	.51	.51	.95	.50
.51	.51	1.67	.00	1.21	1.33	1.50	.73	1.07	1.16
1.39	.89	.99	1.06	1.30	.95	.94	1.02	1.23	.96
.93	.99	1.18	.98	.94	.99	1.12	1.01	.96	.99
1.10	1.02	.99	.99	1.07	1.07	1.03	.99	1.10	1.09
1.07	.99	1.12	1.05	1.06	.94	1.12	1.05	1.06	.94
1.12	1.05	1.06	.94	1.12	1.05	1.06	.94	1.12	1.05
1.06	.94	1.12	1.05	1.06	.94	1.12	1.05	1.06	.94

1.12	1.05	1.06	.94	1.90	.00	1.35	1.49	1.76	.85
1.23	1.37	1.66	1.03	1.15	1.29	1.57	1.12	1.11	1.22
1.50	1.19	1.09	1.20	1.46	1.21	1.09	1.19	1.40	1.24
1.11	1.20	1.38	1.26	1.15	1.22	1.33	1.36	1.22	1.24
1.30	1.26	1.26	1.23	1.30	1.26	1.28	1.18	1.30	1.26
1.28	1.18	1.30	1.26	1.28	1.18	1.30	1.26	1.28	1.18
1.30	1.26	1.28	1.18	1.30	1.26	1.28	1.18	1.30	1.26
1.28	1.18	1.30	1.26	1.28	1.18	2.25	.00	1.47	1.65
2.09	.97	1.33	1.53	1.96	1.21	1.28	1.47	1.88	1.32
1.25	1.43	1.81	1.38	1.25	1.42	1.75	1.41	1.27	1.42
1.68	1.47	1.30	1.44	1.65	1.39	1.33	1.46	1.56	1.49
1.40	1.48	1.49	1.49	1.48	1.48	1.44	1.49	1.49	1.44
1.44	1.49	1.49	1.44	1.44	1.49	1.49	1.44	1.44	1.49
1.49	1.44	1.44	1.49	1.49	1.44	1.44	1.49	1.49	1.44
1.44	1.49	1.49	1.44	1.44	1.49	1.49	1.44		

LAM6(3,1,K),K=1,270

.99	.21	.45	.90	.87	.25	.48	.67	.78	.31
.48	.57	.71	.34	.45	.51	.67	.38	.42	.48
.62	.39	.41	.47	.58	.40	.42	.48	.56	.43
.46	.49	.52	.54	.51	.53	.50	.56	.54	.54
.50	.57	.54	.52	.50	.57	.51	.52	.50	.53
.47	.52	.50	.53	.47	.52	.50	.53	.47	.52
.50	.53	.47	.52	.50	.53	.47	.52	.50	.53
.47	.52	1.20	.34	.93	1.35	1.16	.46	.99	1.20
1.12	.57	1.01	1.10	1.10	.66	1.02	1.02	1.08	.72
1.01	.99	1.06	.76	1.01	.97	1.03	.79	1.05	.95
1.02	.85	1.10	.96	.99	1.01	1.13	1.03	.97	1.12
1.12	1.11	.99	1.14	1.08	1.11	.99	1.14	1.06	1.11
.99	1.10	1.08	1.11	.99	1.10	1.08	1.11	.99	1.10
1.08	1.11	.99	1.10	1.08	1.11	.99	1.10	1.08	1.11
.99	1.11	1.08	1.14	1.27	.42	.96	1.44	1.27	.57
1.02	1.31	1.27	.69	1.06	1.22	1.27	.79	1.09	1.17
1.27	.86	1.10	1.14	1.27	.93	1.10	1.13	1.27	1.01
1.13	1.11	1.27	1.06	1.15	1.11	1.27	1.13	1.24	1.18
1.27	1.21	1.25	1.22	1.27	1.25	1.21	1.24	1.27	1.22
1.18	1.24	1.27	1.22	1.20	1.24	1.27	1.22	1.20	1.24
1.27	1.22	1.20	1.24	1.27	1.22	1.20	1.24	1.27	1.22
1.20	1.24	1.27	1.22	1.20	1.24	.56	.99	1.53	.73
1.08	1.44	.86	1.13	1.37	.97	1.14	1.31	1.07	1.15
1.29	1.13	1.17	1.28	1.21	1.22	1.27	1.34	1.28	1.28

1.31	1.35	1.31	1.35	1.36	1.35	1.35	1.34	1.36	1.35
1.34	1.36	1.35	1.34	1.36	1.35	1.34	1.36	1.35	1.34
1.36	1.35	1.34	1.36	1.35	1.34	1.36	1.35	1.34	1.36
LAM6(3,2,K),K=1,288									
1.08	.05	.86	.99	.94	.20	.59	.70	.85	.30
.48	.58	.77	.37	.43	.51	.70	.42	.47	.48
.66	.47	.50	.47	.61	.50	.55	.48	.58	.54
.56	.50	.53	.54	.56	.54	.49	.54	.55	.54
.47	.54	.57	.49	.47	.54	.57	.49	.47	.54
.57	.49	.47	.54	.57	.49	.47	.54	.57	.49
.47	.54	.57	.49	.47	.54	.57	.49	.47	.54
.57	.49	1.30	.18	1.26	1.47	1.23	.49	1.11	1.17
1.16	.65	1.02	1.02	1.12	.76	.99	.94	1.09	.83
.97	.90	1.06	.86	.97	.90	1.03	.88	.98	.91
1.02	.89	.99	.93	.99	.90	1.04	.99	.97	.90
1.07	1.05	.99	.92	1.08	1.08	.99	.92	1.08	1.08
.99	.92	1.08	1.08	.99	.92	1.08	1.08	.99	.92
1.08	1.08	.99	.92	1.08	1.08	.99	.92	1.08	1.08
.99	.92	1.08	1.08	1.50	.28	1.40	1.62	1.46	.69
1.29	1.35	1.41	.88	1.20	1.22	1.39	.99	1.15	1.14
1.36	1.06	1.13	1.10	1.33	1.11	1.14	1.08	1.31	1.13
1.15	1.08	1.29	1.14	1.19	1.10	1.25	1.14	1.23	1.18
1.24	1.14	1.26	1.23	1.26	1.14	1.26	1.26	1.26	1.14
1.26	1.26	1.26	1.14	1.26	1.26	1.26	1.14	1.26	1.26
1.26	1.14	1.26	1.26	1.26	1.14	1.26	1.26	1.26	1.14
1.26	1.26	1.26	1.14	1.26	1.26	1.80	.46	1.55	1.75
1.77	.93	1.43	1.50	1.75	1.14	1.36	1.38	1.72	1.24
1.32	1.31	1.70	1.31	1.32	1.28	1.68	1.35	1.33	1.26
1.66	1.38	1.35	1.28	1.65	1.39	1.38	1.29	1.63	1.40
1.42	1.36	1.62	1.41	1.44	1.41	1.62	1.42	1.40	1.44
1.62	1.42	1.40	1.44	1.62	1.42	1.40	1.44	1.62	1.42
1.40	1.44	1.62	1.42	1.40	1.44	1.62	1.42	1.40	1.44
1.62	1.42	1.40	1.44	1.62	1.42	1.40	1.44		
LAM6(3,3,K),K=1,288									
1.37	.00	.82	.92	1.10	.26	.64	.75	1.04	.34
.55	.66	.85	.40	.50	.60	.78	.42	.49	.58
.75	.45	.49	.57	.72	.48	.49	.57	.72	.51
.50	.57	.75	.54	.53	.58	.85	.52	.54	.57
.95	.50	.51	.51	.95	.50	.51	.51	.95	.50
.51	.51	.95	.50	.51	.51	.95	.50	.51	.51

.95	.50	.51	.51	.95	.50	.51	.51	.95	.50
.51	.51	1.67	.00	1.21	1.33	1.50	.73	1.07	1.16
1.39	.89	.99	1.06	1.30	.95	.94	1.02	1.23	.96
.93	.99	1.18	.98	.94	.99	1.12	1.01	.96	.99
1.10	1.02	.99	.99	1.07	1.07	1.03	.99	1.10	1.09
1.07	.99	1.12	1.05	1.06	.94	1.12	1.05	1.06	.94
1.12	1.05	1.06	.94	1.12	1.05	1.06	.94	1.12	1.05
1.06	.94	1.12	1.05	1.06	.94	1.12	1.05	1.06	.94
1.12	1.05	1.06	.94	1.90	.00	1.35	1.49	1.76	.85
1.23	1.37	1.66	1.03	1.15	1.29	1.57	1.12	1.11	1.22
1.50	1.19	1.09	1.20	1.46	1.21	1.09	1.19	1.40	1.24
1.11	1.20	1.38	1.26	1.15	1.22	1.33	1.36	1.22	1.24
1.30	1.26	1.26	1.23	1.30	1.26	1.28	1.18	1.30	1.26
1.28	1.18	1.30	1.26	1.28	1.18	1.30	1.26	1.28	1.18
1.30	1.26	1.28	1.18	1.30	1.26	1.28	1.18	1.30	1.26
1.28	1.18	1.30	1.26	1.28	1.18	2.25	.00	1.47	1.65
2.09	.97	1.33	1.53	1.96	1.21	1.28	1.47	1.88	1.32
1.25	1.43	1.81	1.38	1.25	1.42	1.75	1.41	1.27	1.42
1.68	1.47	1.30	1.44	1.65	1.39	1.33	1.46	1.56	1.49
1.40	1.48	1.49	1.49	1.48	1.48	1.44	1.49	1.49	1.44
1.44	1.49	1.49	1.44	1.44	1.49	1.49	1.44	1.44	1.49
1.49	1.44	1.44	1.49	1.49	1.44	1.44	1.49	1.49	1.44
1.44	1.49	1.49	1.44	1.44	1.49	1.49	1.44	1.49	1.44

LAM6(4,1,K),K=1,198

.53	.10	.28	.53	.18	.32	.53	.22	.36	.53
.28	.40	.53	.32	.42	.53	.36	.44	.53	.40
.47	.53	.42	.50	.53	.48	.52	.53	.51	.53
.53	.52	.55	.53	.54	.55	.53	.55	.55	.53
.53	.53	.53	.53	.52	.53	.52	.52	.53	.52
.50	.53	.52	.50	1.10	.28	.77	1.10	.38	.70
1.10	.48	.67	1.10	.58	.65	1.10	.67	.65	1.10
.75	.67	1.10	.83	.70	1.10	.90	.76	1.10	1.01
.89	1.10	1.10	1.00	1.10	1.16	1.05	1.10	1.20	1.07
1.10	1.21	1.04	1.10	1.21	1.01	1.10	1.21	.95	1.10
1.21	.88	1.10	1.21	.86	1.10	1.21	.86	1.57	.63
1.14	1.57	.75	1.08	1.57	.85	1.02	1.57	.94	1.02
1.57	1.03	1.08	.57	1.10	1.12	1.57	1.20	1.19	1.57
1.29	1.27	1.57	1.40	1.40	1.57	1.50	1.50	1.57	1.52
1.56	1.57	1.51	1.60	1.57	1.48	1.62	1.57	1.48	1.59
1.57	1.48	1.49	1.57	1.48	1.41	1.57	1.48	1.41	1.57

1.48	1.41	1.52	2.05	1.36	1.60	1.28	1.37	1.32	1.30
1.38	1.30	1.45	1.31	1.53	1.36	1.60	1.42	1.71	1.55
1.80	1.66	1.82	1.75	1.83	1.80	1.82	1.81	1.77	1.77
1.72	1.71	1.72	1.71	1.72	1.71	1.72	1.71		
LAM6(4,2,K),K=1,288									
.53	.49	.01	.28	.53	.48	.11	.32	.53	.47
.20	.36	.53	.47	.25	.40	.53	.47	.31	.42
.53	.47	.35	.44	.53	.48	.40	.48	.53	.49
.43	.50	.53	.50	.48	.52	.53	.50	.51	.54
.53	.51	.53	.55	.53	.53	.57	.55	.53	.53
.58	.54	.53	.53	.60	.53	.53	.54	.60	.52
.53	.55	.60	.52	.53	.55	.60	.52	.53	.55
.60	.52	1.10	.57	.31	.77	1.10	.64	.38	.70
1.10	.71	.44	.67	1.10	.77	.50	.65	1.10	.81
.58	.65	1.10	.85	.62	.67	1.10	.88	.70	.70
1.10	.91	.77	.76	1.10	.95	.88	.89	1.10	.98
.97	1.00	1.10	1.00	1.01	1.05	1.10	1.00	1.03	1.07
1.10	1.01	1.02	1.04	1.10	1.03	1.01	1.00	1.10	1.03
.98	.95	1.10	1.04	.91	.86	1.10	1.04	.91	.86
1.10	1.04	.91	.86	1.57	1.02	.80	1.14	1.57	1.12
.90	1.08	1.57	1.20	.99	1.02	1.57	1.25	1.07	1.02
1.57	1.30	1.13	1.08	1.57	1.32	1.20	1.12	1.57	1.36
1.27	1.19	1.57	1.38	1.30	1.27	1.57	1.37	1.38	1.40
1.57	1.35	1.40	1.49	1.57	1.37	1.42	1.56	1.57	1.39
1.43	1.50	1.57	1.42	1.45	1.61	1.57	1.47	1.47	1.59
1.57	1.53	1.48	1.49	1.57	1.55	1.48	1.41	1.57	1.55
1.48	1.41	1.57	1.55	1.48	1.41	1.89	1.60	1.58	2.05
1.89	1.56	1.52	1.60	1.89	1.53	1.50	1.37	1.89	1.52
1.47	1.30	1.89	1.52	1.44	1.30	1.89	1.53	1.43	1.31
1.89	1.56	1.47	1.37	1.89	1.58	1.51	1.41	1.89	1.62
1.63	1.55	1.89	1.69	1.72	1.67	1.89	1.72	1.76	1.75
1.89	1.78	1.77	1.80	1.89	1.82	1.74	1.81	1.89	1.86
1.71	1.78	1.89	1.82	1.74	1.81	1.89	1.82	1.74	1.81
1.89	1.82	1.74	1.81	1.89	1.82	1.74	1.81		
LAM6(4,3,K),K=1,108									
.53	.04	.28	.53	.11	.32	.53	.17	.36	.53
.20	.40	.53	.23	.42	.53	.26	.44	.53	.30
.47	.53	.34	.49	.53	.41	.52	.53	.48	.53
.53	.50	.55	.53	.53	.55	.53	.55	.55	.53
.53	.53	.53	.52	.52	.53	.49	.52	.53	.47

.50	.53	.47	.50	1.89	1.10	2.05	1.89	1.12	1.60
1.89	1.15	1.37	1.89	1.20	1.30	1.89	1.24	1.30	1.89
1.30	1.30	1.89	1.39	1.37	1.89	1.48	1.41	1.89	1.64
1.55	1.89	1.73	1.67	1.89	1.79	1.75	1.89	1.80	1.80
1.89	1.80	1.81	1.89	1.78	1.70	1.89	1.78	1.70	1.89
1.78	1.70	1.89	1.78	1.70	1.89	1.78	1.70		

LAM6(5,1,K),K=1,90

.52	.60	.23	.52	.57	.28	.52	.53	.36	.52
.52	.40	.52	.50	.45	.52	.50	.50	.52	.50
.55	.52	.50	.60	.52	.50	.66	.52	.49	.70
.52	.48	.70	.52	.48	.69	.52	.48	.66	.52
.49	.60	.52	.50	.53	.52	.50	.46	.52	.52
.40	.52	.52	.40	1.30	.92	1.42	1.05	1.52	1.17
1.60	1.26	1.68	1.33	1.71	1.40	1.75	1.46	1.77	1.52
1.77	1.61	1.73	1.66	1.75	1.70	1.80	1.76	1.87	1.82
1.95	1.88	2.02	1.91	2.02	1.91	2.02	1.91	2.02	1.91

LAM6(5,2,K),K=1,288

.52	.75	.28	.23	.52	.69	.30	.28	.52	.64
.32	.36	.52	.60	.32	.40	.52	.57	.34	.45
.52	.52	.36	.50	.52	.51	.37	.55	.52	.50
.37	.60	.52	.48	.38	.66	.52	.47	.38	.70
.52	.46	.41	.70	.52	.45	.43	.69	.52	.45
.47	.66	.52	.46	.50	.60	.52	.47	.53	.53
.52	.49	.58	.47	.52	.51	.63	.40	.52	.51
.63	.40	1.02	1.00	.55	.38	1.02	.97	.60	.42
1.02	.92	.65	.50	1.02	.90	.70	.55	1.02	.89
.73	.62	1.02	.88	.77	.67	1.02	.87	.80	.73
1.02	.86	.84	.78	1.02	.83	.90	.88	1.02	.84
.96	.92	1.02	.84	1.00	.92	1.02	.87	1.02	.93
1.02	.90	1.04	.93	1.02	.96	1.05	.96	1.02	1.03
1.06	.98	1.02	1.12	1.04	1.02	1.02	1.13	1.04	1.02
1.02	1.13	1.04	1.02	1.47	1.23	.69	.60	1.47	1.25
.80	.75	1.47	1.27	.89	.88	1.47	1.28	.97	.99
1.47	1.28	1.02	1.09	1.47	1.30	1.08	1.17	1.47	1.30
1.12	1.25	1.47	1.30	1.18	1.30	1.47	1.30	1.25	1.34
1.47	1.30	1.30	1.32	1.47	1.30	1.34	1.31	1.47	1.32
1.38	1.30	1.47	1.37	1.40	1.31	1.47	1.41	1.42	1.36
1.47	1.48	1.43	1.42	1.47	1.50	1.45	1.48	1.47	1.50
1.45	1.48	1.47	1.50	1.45	1.48	1.89	1.46	1.00	.92
1.89	1.52	1.21	1.05	1.89	1.58	1.37	1.17	1.89	1.62

1.48	1.25	1.89	1.67	1.55	1.32	1.89	1.69	1.60	1.40
1.89	1.72	1.67	1.47	1.89	1.72	1.68	1.52	1.89	1.72
1.70	1.61	1.89	1.70	1.70	1.66	1.89	1.71	1.68	1.70
1.89	1.76	1.68	1.76	1.89	1.84	1.80	1.81	1.89	1.95
1.97	1.88	1.89	2.00	2.03	1.90	1.89	2.00	2.03	1.90
1.89	2.00	2.03	1.90	1.89	2.00	2.03	1.90		

LAM6(5,3,K),K=1,108

.52	.46	.23	.52	.44	.28	.52	.43	.36	.52
.42	.40	.52	.41	.45	.52	.40	.50	.52	.40
.55	.52	.40	.60	.52	.40	.66	.52	.40	.70
.52	.40	.70	.52	.42	.69	.52	.45	.66	.52
.47	.60	.52	.50	.53	.52	.52	.47	.52	.52
.40	.52	.52	.40	1.89	1.46	.92	1.89	1.50	1.05
1.89	1.55	1.17	1.89	1.58	1.25	1.89	1.60	1.32	1.89
1.62	1.40	1.89	1.63	1.47	1.89	1.63	1.52	1.89	1.66
1.61	1.89	1.67	1.66	1.89	1.72	1.70	1.89	1.78	1.76
1.89	1.85	1.81	1.89	1.95	1.88	1.89	2.00	1.90	1.89
2.00	1.90	1.89	2.00	1.90	1.89	2.00	1.90		

LAM6(6,1,K),K=1,90

.52	.74	.20	.52	.51	.13	.52	.40	.12	.52
.40	.12	.52	.40	.13	.52	.40	.14	.52	.43
.16	.52	.46	.18	.52	.49	.24	.52	.51	.32
.52	.53	.40	.52	.55	.47	.52	.57	.51	.52
.57	.55	.52	.56	.57	.52	.52	.55	.52	.42
.45	.52	.42	.45	1.40	1.51	1.53	1.40	1.62	1.33
1.70	1.30	1.76	1.30	1.80	1.31	1.82	1.36	1.83	1.41
1.84	1.55	1.82	1.68	1.81	1.78	1.82	1.82	1.89	1.87
2.00	1.83	2.10	1.79	2.10	1.79	2.10	1.79	2.10	1.79

LAM6(6,2,K),K=1,288

.52	.82	.63	.20	.52	.60	.39	.13	.52	.46
.33	.12	.52	.45	.33	.12	.52	.46	.34	.13
.52	.47	.34	.14	.52	.48	.35	.16	.52	.49
.35	.18	.52	.50	.37	.24	.52	.50	.40	.32
.52	.51	.44	.40	.52	.52	.50	.47	.52	.52
.53	.51	.52	.50	.53	.55	.52	.51	.52	.57
.52	.49	.53	.55	.52	.40	.48	.45	.52	.40
.48	.45	1.02	1.01	.70	.50	1.02	.85	.57	.48
.02	.76	.53	.46	1.02	.74	.52	.46	1.02	.75
.52	.48	1.02	.77	.52	.50	1.02	.80	.53	.53
1.02	.82	.57	.58	1.02	.85	.70	.68	1.02	.88

.83	.78	1.02	.89	.90	.86	1.02	.90	.97	.92
1.02	.90	.99	.97	1.02	.92	.98	1.03	1.02	.92
.92	1.10	1.02	.93	.80	1.15	1.02	.93	.78	1.16
1.02	.93	.78	1.16	1.48	1.34	.77	1.10	1.48	1.20
.82	1.08	1.48	1.08	.89	1.06	1.48	1.03	.93	1.05
1.48	1.02	.99	1.06	1.48	1.03	1.02	1.08	1.48	1.08
1.08	1.10	1.48	1.12	1.12	1.13	1.48	1.23	1.20	1.19
1.48	1.33	1.27	1.23	1.48	1.40	1.30	1.24	1.48	1.47
1.33	1.24	1.48	1.50	1.37	1.24	1.48	1.47	1.38	1.28
1.48	1.39	1.39	1.33	1.48	1.33	1.39	1.37	1.48	1.33
1.39	1.37	1.48	1.33	1.39	1.37	1.92	1.45	.99	1.51
1.92	1.54	1.09	1.40	1.92	1.60	1.18	1.33	1.92	1.66
1.25	1.30	1.92	1.70	1.32	1.30	1.92	1.73	1.40	1.31
1.92	1.76	1.47	1.36	1.92	1.77	1.53	1.41	1.92	1.78
1.64	1.55	1.92	1.79	1.72	1.68	1.92	1.81	1.80	1.78
1.92	1.86	1.85	1.82	1.92	1.92	1.90	1.87	1.92	2.02
1.93	1.83	1.92	2.10	1.95	1.79	1.92	2.10	1.95	1.79
1.92	2.10	1.95	1.79	1.92	2.10	1.95	1.79		

LAM6(6,3,K),K=1,108

.52	.84	.20	.52	.50	.13	.52	.36	.12	.52
.34	.12	.52	.35	.13	.52	.38	.14	.52	.40
.16	.52	.42	.18	.52	.46	.24	.52	.48	.32
.52	.49	.40	.52	.50	.47	.52	.50	.51	.52
.48	.55	.52	.47	.57	.52	.42	.55	.52	.39
.45	.52	.39	.45	1.92	1.42	1.51	1.92	1.44	1.40
1.92	1.48	1.33	1.92	1.50	1.30	1.92	1.53	1.30	1.92
1.58	1.31	1.92	1.61	1.36	1.92	1.65	1.41	1.92	1.72
1.55	1.92	1.80	1.68	1.92	1.88	1.78	1.92	1.93	1.82
1.92	1.99	1.87	1.92	2.03	1.83	1.92	2.09	1.79	1.92
2.09	1.79	1.92	2.09	1.79	1.92	2.09	1.79		

LAM6(7,1,K),K=1,90

.52	.74	.30	.52	.72	.30	.52	.70	.30	.52
.68	.30	.52	.65	.30	.52	.62	.30	.52	.60
.30	.52	.58	.30	.52	.53	.32	.52	.49	.36
.52	.47	.38	.52	.43	.40	.52	.42	.41	.52
.45	.42	.52	.48	.43	.52	.54	.43	.52	.60
.45	.52	.60	.45	2.05	1.80	1.90	1.60	1.80	1.49
1.76	1.42	1.72	1.39	1.73	1.38	1.76	1.41	1.81	1.48
1.95	1.64	2.08	1.80	2.19	1.92	2.25	1.99	2.28	2.01
2.30	1.98	2.30	1.90	2.30	1.90	2.30	1.90	2.30	1.90

LAM6(7,2,K),K=1,288

.52	.72	.40	.30	.52	.70	.41	.30	.52	.68
.42	.30	.52	.65	.43	.30	.52	.62	.44	.30
.52	.61	.44	.30	.52	.60	.45	.30	.52	.58
.45	.30	.52	.54	.44	.32	.52	.51	.43	.36
.52	.50	.41	.38	.52	.48	.40	.40	.52	.47
.41	.41	.52	.46	.42	.42	.52	.44	.48	.43
.52	.43	.50	.43	.52	.43	.53	.45	.52	.43
.53	.45	1.02	1.22	1.08	.73	1.02	1.12	.93	.64
1.02	1.03	.82	.58	1.02	.97	.75	.52	1.02	.92
.70	.50	1.02	.88	.66	.49	1.02	.84	.63	.48
1.02	.81	.62	.50	1.02	.78	.65	.57	1.02	.78
.73	.66	1.02	.79	.83	.76	1.02	.82	.92	.84
1.02	.87	1.00	.91	1.02	.92	1.03	.98	1.02	1.00
1.02	.98	1.02	1.08	.97	.96	1.02	1.09	.95	.94
1.02	1.09	.95	.94	1.52	1.60	1.60	1.03	1.52	1.45
1.33	.98	1.52	1.33	1.20	.94	1.52	1.25	1.10	.93
1.50	1.20	1.05	.92	1.52	1.18	1.02	.93	1.52	1.18
1.02	.95	1.52	1.19	1.04	.98	1.52	1.23	1.15	1.08
1.52	1.31	1.30	1.19	1.52	1.38	1.43	1.30	1.52	1.48
1.54	1.39	1.52	1.58	1.59	1.46	1.52	1.71	1.57	1.48
1.52	1.83	1.45	1.46	1.52	1.90	1.36	1.43	1.52	1.90
1.36	1.43	1.52	1.90	1.36	1.43	1.98	1.88	2.03	1.80
1.98	1.73	1.77	1.60	1.98	1.64	1.62	1.49	1.98	1.60
1.53	1.42	1.98	1.58	1.49	1.39	1.98	1.58	1.48	1.38
1.98	1.63	1.50	1.41	1.98	1.72	1.54	1.48	1.98	1.93
1.72	1.64	1.98	2.10	1.97	1.80	1.98	2.19	2.08	1.92
1.98	2.24	2.33	1.99	1.98	2.27	2.40	2.01	1.98	2.27
2.39	1.98	1.98	2.27	2.32	1.90	1.98	2.27	2.32	1.90
1.98	2.27	2.32	1.90	1.98	2.27	2.32	1.90		

LAM6(7,3,K),K=1,108

.52	.51	.30	.52	.56	.30	.52	.51	.30	.52
.48	.30	.52	.44	.30	.52	.42	.30	.52	.40
.30	.52	.38	.30	.52	.37	.32	.52	.36	.36
.52	.37	.38	.52	.38	.40	.52	.40	.41	.52
.43	.42	.52	.48	.43	.52	.52	.43	.52	.57
.45	.52	.57	.45	1.98	1.81	1.80	1.98	1.60	1.60
1.98	1.50	1.49	1.98	1.43	1.42	1.98	1.40	1.39	1.98
1.41	1.38	1.98	1.47	1.41	1.98	1.55	1.48	1.98	1.78
1.64	1.98	2.02	1.80	1.98	2.20	1.92	1.98	2.31	1.99

1.98	2.40	2.01	1.98	2.48	1.98	1.98	2.48	1.90	1.98
2.48	1.90	1.98	2.48	1.91	1.98	2.48	1.91		
LAM6(8,1,K),K=1,288									
.543	.561	.561	.561	.543	.557	.557	.557	.543	.555
.555	.555	.543	.553	.553	.553	.543	.552	.552	.552
.543	.551	.551	.551	.543	.549	.549	.549	.543	.548
.548	.548	.543	.546	.546	.546	.543	.545	.545	.545
.543	.545	.545	.545	.543	.545	.545	.545	.543	.544
.544	.544	.543	.543	.543	.543	.543	.543	.543	.543
.543	.543	.543	.543	.543	.543	.543	.543	.543	.543
.543	.543	1.070	1.333	1.333	1.333	1.070	1.298	1.298	1.298
1.070	1.275	1.275	1.275	1.070	1.257	1.257	1.257	1.070	1.243
1.243	1.243	1.070	1.070	1.070	1.070	1.070	1.070	1.222	1.070
1.070	1.070	1.208	1.070	1.070	1.070	1.070	1.070	1.070	1.070
1.070	1.070	1.070	1.070	1.070	1.070	1.070	1.070	1.070	1.070
1.070	1.070	1.070	1.070	1.070	1.070	1.070	1.070	1.070	1.070
1.070	1.070	1.070	1.070	1.070	1.070	1.070	1.070	1.070	1.070
1.070	1.070	1.070	1.070	1.564	2.408	2.408	2.408	1.564	2.294
2.294	2.294	1.564	2.205	2.205	2.205	1.564	1.564	2.144	2.144
1.564	1.564	2.097	2.097	1.564	1.564	1.564	2.051	1.564	1.564
1.564	2.010	1.564	1.564	1.564	1.966	1.564	1.564	1.564	1.564
1.564	1.564	1.564	1.564	1.564	1.564	1.564	1.564	1.564	1.564
1.564	1.564	1.564	1.564	1.564	1.564	1.564	1.564	1.564	1.564
1.564	1.564	1.564	1.564	1.564	1.564	1.564	1.564	1.564	1.564
1.564	1.564	1.564	1.564	1.564	1.564	2.011	3.753	3.753	3.753
2.011	3.459	3.459	3.459	2.011	2.011	3.269	3.269	2.011	2.011
3.137	3.137	2.011	2.011	2.011	3.014	2.011	2.011	2.011	2.917
2.011	2.011	2.011	2.401	2.011	2.011	2.011	2.011	2.011	2.011
2.011	2.011	2.011	2.011	2.011	2.011	2.011	2.011	2.011	2.011
2.011	2.011	2.011	2.011	2.011	2.011	2.011	2.011	2.011	2.011
2.011	2.011	2.011	2.011	2.011	2.011	2.011	2.011	2.011	2.011
2.011	2.011	2.011	2.011	2.011	2.011	2.011	2.011	2.011	2.011
LAM6(8,2,K),K=1,288									
.543	.561	.561	.561	.543	.557	.557	.557	.543	.555
.555	.555	.543	.553	.553	.553	.543	.552	.552	.552
.543	.551	.551	.551	.543	.549	.549	.549	.543	.548
.548	.548	.543	.546	.546	.546	.543	.545	.545	.545
.543	.545	.545	.545	.543	.545	.545	.545	.543	.544
.544	.544	.543	.543	.543	.543	.543	.543	.543	.543
.543	.543	.543	.543	.543	.543	.543	.543	.543	.543

.543	.543	1.070	1.333	1.333	1.333	1.070	1.298	1.298	1.298
1.070	1.275	1.275	1.275	1.070	1.257	1.257	1.257	1.070	1.243
1.243	1.243	1.070	1.070	1.070	1.070	1.070	1.070	1.222	1.070
1.070	1.070	1.208	1.070	1.070	1.070	1.070	1.070	1.070	1.070
1.070	1.070	1.070	1.070	1.070	1.070	1.070	1.070	1.070	1.070
1.070	1.070	1.070	1.070	1.070	1.070	1.070	1.070	1.070	1.070
1.070	1.070	1.070	1.070	1.070	1.070	1.070	1.070	1.070	1.070
1.070	1.070	1.070	1.070	1.564	2.408	2.408	2.408	1.564	2.294
2.294	2.294	1.564	2.205	2.205	2.205	1.564	1.564	2.144	2.144
1.564	1.564	2.097	2.097	1.564	1.564	1.564	2.051	1.564	1.564
1.564	2.010	1.564	1.564	1.564	1.966	1.564	1.564	1.564	1.564
1.564	1.564	1.564	1.564	1.564	1.564	1.564	1.564	1.564	1.564
1.564	1.564	1.564	1.564	1.564	1.564	1.564	1.564	1.564	1.564
1.564	1.564	1.564	1.564	1.564	1.564	1.564	1.564	1.564	1.564
1.564	1.564	1.564	1.564	1.564	1.564	2.011	3.753	3.753	3.753
2.011	3.459	3.459	3.459	2.011	2.011	3.269	3.269	2.011	2.011
3.137	3.137	2.011	2.011	2.011	3.014	2.011	2.011	2.011	2.917
2.011	2.011	2.011	2.401	2.011	2.011	2.011	2.011	2.011	2.011
2.011	2.011	2.011	2.011	2.011	2.011	2.011	2.011	2.011	2.011
2.011	2.011	2.011	2.011	2.011	2.011	2.011	2.011	2.011	2.011
2.011	2.011	2.011	2.011	2.011	2.011	2.011	2.011	2.011	2.011
2.011	2.011	2.011	2.011	2.011	2.011	2.011	2.011	2.011	2.011
2.011	2.011	2.011	2.011	2.011	2.011	2.011	2.011	2.011	2.011

FIXED INPUT DATA FOR CYLINDERS FOLLOWING FRUSTUMS

NMACH(7)

8

NXD7

24

NDDR7(I), I=1,8

1 1 1 3 3 3 3 2

NTHF7(I,J), I=1,8 J=1,NDDR7(I)

4

4

4

2 2 2

3 3 2

3 3 2

3 3 2

2 2

NLAM7(I,J), I=1,8 J=1,NDDR7(I)

96

96

96

48 48 48

72 72 48

72 72 48

72 72 48

48 48

MACH(7,I), I=1,8

.80 1.00 1.20 1.50 2.50 3.50 5.00 15.00

XD7(I), I=1,24

0.0 .1 .2 .3 .4 .5 .6 .7 .8 .9

1.00 1.25 1.50 1.75 2.00 2.50 3.00 3.50 4.00 4.50

5.00 5.50 6.00 6.50

DDR7(I,J), I=1,8 J=1,NDDR7(I)

.70

.70

.70

.25 .50 .75

.25 .50 .75

.25 .50 .75

.25 .50 .75

.25 .50

THF7(1,J,K),J=1,NDDR7(1) K=1,NTHF7(1,J)
 5.0 10.0 15.0 30.0

THF7(2,J,K),J=1,NDDR7(2) K=1,NTHF7(2,J)
 5.0 10.0 15.0 30.0

THF7(3,J,K),J=1,NDDR7(3) K=1,NTHF7(3,J)
 5.0 10.0 15.0 30.0

THF7(4,J,K),J=1,NDDR7(4) K=1,NTHF7(4,J)
 5.0 10.0
 5.0 10.0
 5.0 10.0

THF7(5,J,K),J=1,NDDR7(5) K=1,NTHF7(5,J)
 5.0 10.0 20.0
 5.0 10.0 20.0
 5.0 20.0

THF7(6,J,K),J=1,NDDR7(6) K=1,NTHF7(6,J)
 5.0 10.0 20.0
 5.0 10.0 20.0
 5.0 20.0

THF7(7,J,K),J=1,NDDR7(7) K=1,NTHF7(7,J)
 5.0 10.0 20.0
 5.0 10.0 20.0
 5.0 20.0

THF7(8,J,K),J=1,NDDR7(8) K=1,NTHF7(8,J)
 5.00 10.00
 5.00 10.00

LAM7(1,1,K),K=1,96

-.370	-1.140	-1.140	-1.500	-.070	.120	.570	-1.400	.040	.160
.580	-1.300	.075	.145	.400	-.220	.087	.130	.205	.600
.088	.110	.160	.685	.079	.100	.128	.590	.062	.080
.100	.400	.055	.070	.080	.310	.050	.060	.072	.245
.048	.058	.070	.200	.050	.055	.065	.155	.060	.060
.060	.130	.070	.050	.050	.120	.070	.085	.090	.147
.060	.088	.092	.130	.059	.080	.080	.120	.060	.070
.070	.128	.060	.075	.072	.120	.060	.080	.080	.110
.060	.087	.080	.095	.060	.087	.080	.095	.060	.087
.080	.095	.060	.087	.080	.095				

LAM7(2,1,K),K=1,96

.347	1.200	.510	.130	.345	.630	.360	-.170	.340	.460
.320	-.140	.330	.620	.530	.340	.300	.620	.740	.818
.030	.540	.750	.855	-.060	.350	.540	.840	-.118	.140

.240	.720	-.180	-.020	.060	.280	-.215	-.160	-.060	.040
-.210	-.248	-.170	-.090	-.110	-.280	-.320	-.240	-.030	-.255
-.333	-.300	.020	-.120	-.210	-.190	.050	.080	-.113	-.070
.070	.120	-.080	.033	.080	.120	-.025	.080	.085	.115
.040	.115	.085	.100	.070	.132	.080	.092	.068	.140
.068	.090	.060	.125	.055	.090	.060	.100	.055	.090
.060	.100	.055	.090	.060	.100				
LAM7(3,1,K),K=1,96									
.580	.720	.450	.260	.470	.500	.200	-.440	.410	.420
.150	-.430	.380	.460	.270	.450	.340	.458	.350	.520
.295	.430	.390	.390	.235	.390	.430	.452	.180	.350
.410	.450	.130	.300	.355	.440	.090	.240	.290	.390
.058	.175	.240	.300	-.010	.040	.130	.145	-.020	.000
.060	.070	.015	-.010	.035	.040	-.015	-.020	.020	.020
.010	-.015	.010	-.010	.060	.020	.050	.005	.110	.070
.100	.045	.135	.110	.145	.100	.110	.130	.159	.130
.020	.050	.100	.060	.000	.050	.040	.050	.000	.050
.040	.050	.000	.050	.040	.050				
LAM7(4,1,K),K=1,48									
.374	.723	.355	.652	.338	.590	.320	.534	.304	.485
.286	.440	.272	.406	.258	.372	.243	.340	.226	.317
.214	.290	.181	.242	.145	.208	.128	.173	.110	.146
.087	.118	.046	.059	.030	.033	.018	.018	.010	.010
.007	.007	.005	.005	.003	.003	.003	.003		
LAM7(4,2,K),K=1,48									
.249	.710	.251	.620	.253	.548	.250	.484	.248	.430
.244	.387	.240	.352	.237	.318	.230	.290	.222	.263
.215	.240	.195	.197	.170	.170	.145	.145	.130	.130
.115	.115	.084	.084	.070	.070	.058	.058	.045	.045
.036	.036	.025	.025	.015	.015	.015	.015		
LAM7(4,3,K),K=1,48									
.220	.220	.208	.208	.194	.194	.185	.185	.174	.174
.165	.165	.157	.157	.147	.147	.140	.140	.133	.133
.128	.128	.115	.115	.100	.100	.092	.092	.086	.086
.077	.077	.060	.060	.052	.052	.045	.045	.040	.040
.037	.037	.035	.035	.030	.030	.030	.030		
LAM7(5,1,K),K=1,72									
.277	.530	.805	.274	.503	.738	.272	.474	.678	.270
.450	.626	.267	.415	.576	.264	.403	.534	.261	.382
.500	.257	.364	.470	.255	.375	.440	.252	.329	.415

.246	.313	.390	.235	.186	.345	.224	.260	.310	.210
.240	.276	.194	.218	.250	.159	.181	.201	.122	.149
.160	.088	.120	.122	.060	.092	.092	.040	.070	.070
.026	.054	.054	.015	.041	.045	.008	.034	.034	.008
.034	.034								
LAM7(5,2,K),K=1,72									
.233	.486	.561	.234	.466	.538	.234	.446	.512	.233
.426	.490	.231	.408	.464	.229	.385	.438	.226	.366
.415	.225	.350	.393	.220	.330	.372	.217	.313	.350
.210	.284	.330	.200	.256	.282	.184	.220	.242	.164
.190	.205	.149	.162	.174	.117	.127	.128	.094	.100
.100	.080	.080	.080	.065	.065	.065	.050	.050	.050
.038	.038	.038	.028	.028	.028	.015	.015	.015	.015
.015	.015								
LAM7(5,3,K),K=1,48									
.180	.180	.173	.173	.166	.166	.160	.160	.154	.154
.138	.138	.144	.144	.138	.138	.133	.133	.127	.127
.124	.124	.112	.112	.104	.104	.096	.096	.080	.080
.079	.079	.069	.069	.062	.062	.060	.060	.055	.055
.052	.052	.052	.052	.050	.050	.050	.050		
LAM7(6,1,K),K=1,72									
.278	.540	.820	.276	.510	.750	.274	.480	.688	.272
.452	.632	.270	.428	.586	.266	.405	.542	.264	.385
.508	.260	.366	.476	.258	.346	.446	.254	.331	.422
.250	.315	.396	.239	.286	.350	.228	.260	.314	.213
.238	.280	.197	.220	.250	.161	.185	.206	.120	.150
.143	.090	.120	.128	.065	.095	.095	.045	.072	.072
.030	.055	.055	.019	.045	.045	.010	.032	.032	.010
.032	.032								
LAM7(6,2,K),K=1,72									
.254	.412	.490	.250	.400	.472	.246	.389	.455	.239
.372	.440	.232	.360	.424	.228	.348	.408	.220	.335
.390	.216	.323	.377	.210	.310	.360	.205	.299	.345
.199	.286	.330	.186	.257	.291	.172	.230	.260	.160
.203	.230	.150	.180	.196	.128	.139	.148	.108	.113
.115	.090	.090	.090	.072	.072	.072	.058	.058	.058
.042	.042	.042	.028	.028	.028	.015	.015	.015	.015
.015	.015								
LAM7(6,3,K),K=1,48									
.135	.135	.133	.133	.131	.131	.129	.129	.127	.127

.125	.125	.121	.121	.119	.119	.118	.118	.115	.115
.112	.112	.108	.108	.104	.104	.100	.100	.092	.092
.084	.084	.075	.075	.067	.067	.060	.060	.059	.059
.054	.054	.055	.055	.054	.054	.054	.054		

LAM7(7,1,K),K=1,72

.340	.360	.500	.330	.346	.466	.320	.332	.434	.311
.320	.402	.300	.310	.376	.290	.298	.351	.280	.289
.332	.273	.277	.312	.262	.265	.294	.256	.260	.280
.246	.250	.268	.231	.233	.240	.212	.220	.220	.200
.216	.216	.190	.209	.208	.177	.197	.197	.167	.187
.187	.150	.170	.170	.134	.153	.153	.115	.135	.135
.095	.113	.113	.072	.092	.092	.050	.070	.070	.050
.070	.070								

LAM7(7,2,K),K=1,72

.220	.261	.290	.220	.260	.287	.220	.257	.280	.220
.252	.272	.220	.243	.267	.220	.239	.260	.219	.234
.253	.216	.231	.250	.216	.216	.245	.213	.220	.239
.210	.208	.232	.204	.204	.220	.195	.195	.208	.186
.186	.192	.174	.174	.185	.154	.154	.160	.134	.134
.140	.118	.120	.120	.100	.100	.100	.080	.080	.080
.063	.063	.063	.045	.045	.045	.028	.028	.028	.028
.028	.028								

LAM7(7,3,K),K=1,48

.146	.146	.143	.143	.140	.140	.138	.138	.133	.133
.131	.131	.130	.130	.128	.128	.126	.126	.123	.123
.119	.119	.113	.113	.108	.108	.102	.102	.093	.093
.084	.084	.072	.072	.067	.067	.060	.060	.058	.058
.054	.054	.056	.056	.054	.054	.054	.054		

LAM7(8,1,K),K=1,48

.116	.116	.116	.116	.116	.116	.116	.116	.116	.116
.116	.116	.116	.116	.116	.116	.116	.116	.116	.116
.116	.116	.116	.116	.116	.116	.116	.116	.116	.116
.116	.116	.116	.116	.116	.116	.116	.116	.116	.116
.116	.116	.116	.116	.116	.116	.116	.116		

LAM7(8,2,K),K=1,48

.116	.116	.116	.116	.116	.116	.116	.116	.116	.116
.116	.116	.116	.116	.116	.116	.116	.116	.116	.116
.116	.116	.116	.116	.116	.116	.116	.116	.116	.116
.116	.116	.116	.116	.116	.116	.116	.116	.116	.116
.116	.116	.116	.116	.116	.116	.116	.116		

FIXED INPUT DATA FOR BOATTAILS FOLLOWING LONG CYLINDERS

```

NMACH(8)
  8
NXD8
  12
NTHB8(I),I=1,8
  5   4   5   4   5   5   4   5
NLAMB(I),I=1,8
  60  48  60  48  60  60  48  60
MACH(8,I),I=1,8
  1.50  1.91  2.00  2.50  3.00  5.00  6.00  15.00
XD8(I),I=1,12
  .00   .10   .20   .40   .60   .80  1.00  1.25  1.50  1.75
  2.00  2.50
THB8(I,J),I=1,8 J=1,NTHB8(I)
  0.0   4.0   8.0  12.0  16.0
  0.0   5.6   7.0   9.3
  0.0   4.0   8.0  12.0  16.0
  0.0   4.0   8.0  12.0
  0.0   2.0   4.0   8.0  12.0
  0.0   2.0   4.0   8.0  12.0
  0.0   6.0  12.0  18.0
  0.0   4.0   8.0  12.0  16.0
LAMB(1,J),J=1,60
  .000   .000  -.030  -.035  -.060   .000  -.020  -.060  -.085  -.040
  .000  -.048  -.105  -.150  -.032   .000  -.120  -.240  -.320  -.120
  .000  -.220  -.412  -.660 -1.200   .000  -.261  -.590 -1.100 -1.480
  .000  -.250  -.790 -1.330   .000   .000  -.170  -.860 -1.400  -.240
  .000  -.100  -.820 -1.380  -.150   .000  -.060  -.760 -1.300  -.090
  .000  -.040  -.710 -1.190  -.060   .000  -.040  -.710 -1.190  -.060
LAMB(2,J),J=1,48
  .000  -.050  -.155  -.157   .000  -.080  -.168  -.170   .000  -.112
  -.182  -.189   .000  -.174  -.220  -.230   .000  -.235  -.263  -.283
  .000  -.295  -.318  -.355   .000  -.346  -.350  -.393   .000  -.378
  -.354  -.410   .000  -.380  -.354  -.420   .000  -.369  -.352  -.417
  .000  -.358  -.348  -.396   .000  -.358  -.348  -.396
LAMB(3,J),J=1,60
  .000  -.030  -.030  -.090   .000   .000  -.048  -.062  -.132  -.048
  .000  -.064  -.095  -.180  -.105   .000  -.100  -.160  -.280  -.240
  .000  -.129  -.232  -.380  -.390   .000  -.155  -.312  -.500  -.470

```

.000	-.175	-.408	-.630	-.170	.000	-.160	-.450	-.650	-.090
.000	-.110	-.450	-.620	-.050	.000	-.060	-.410	-.570	-.020
.000	-.030	-.400	-.530	-.010	.000	-.030	-.400	-.530	-.010
LAMB(4,J),J=1,48									
.000	-.040	-.075	-.110	.000	-.050	-.100	-.140	.000	-.065
-.120	-.170	.000	-.092	-.159	-.228	.000	-.116	-.188	-.280
.000	-.130	-.215	-.325	.000	-.130	-.240	-.368	.000	-.120
-.240	-.390	.000	-.100	-.210	-.390	.000	-.060	-.160	-.340
.000	-.030	-.130	-.290	.000	-.030	-.130	-.290		
LAMB(5,J),J=1,60									
.000	.000	.000	.000	.000	.000	-.010	-.020	-.030	-.050
.000	-.020	-.040	-.079	-.120	.000	-.038	-.050	-.165	-.280
.000	-.040	-.130	-.280	-.470	.000	-.048	-.180	-.418	-.720
.000	-.058	-.225	-.557	-1.020	.000	-.023	-.300	-.760	-1.480
.000	-.065	-.390	-.940	-2.020	.000	-.065	-.450	-1.140	-2.150
.000	-.065	-.500	-1.300	-2.150	.000	-.065	-.500	-1.300	-2.150
LAMB(6,J),J=1,60									
.000	.000	.000	.000	.000	.000	.000	-.010	-.010	-.010
.000	-.020	-.030	-.032	-.042	.000	-.050	-.062	-.080	-.115
.000	-.075	-.090	-.133	-.198	.000	-.092	-.108	-.200	-.325
.000	-.105	-.135	-.282	-.550	.000	-.120	-.180	-.410	-.810
.000	-.150	-.222	-.545	-.950	.000	-.130	-.268	-.730	-.930
.000	-.100	-.319	-.920	-.875	.000	-.100	-.319	-.920	-.875
LAMB(7,J),J=1,48									
.000	-.034	-.075	-.250	.000	-.125	-.413	-.612	.000	-.108
-.346	-.529	.000	-.080	-.245	-.383	.000	-.062	-.180	-.303
.000	-.053	-.131	-.240	.000	-.049	-.088	-.182	.000	-.049
-.050	-.100	.000	-.049	-.050	-.050	.000	-.049	-.050	-.050
.000	-.049	-.050	-.050	.000	-.049	-.050	-.050		
LAMB(8,J),J=1,60									
.000	.003	.000	.000	.000	.000	.003	.000	.000	.000
.000	.003	.000	.000	.000	.000	.003	.000	.000	.000
.000	.003	.000	.000	.000	.000	.003	.000	.000	.000
.000	.003	.000	.000	.000	.000	.003	.000	.000	.000
.000	.003	.000	.000	.000	.000	.003	.000	.000	.000
.000	.003	.000	.000	.000	.000	.003	.000	.000	.000

REFERENCES

1. Muraca, Ralph J.: An Empirical Method for Determining Static Distributed Aerodynamic Loads on Axisymmetric Multistage Launch Vehicles. NASA TN D-3283, 1966.
2. Johnson, Benford H.; and Hamner, Roger L.: A Summary of the Trisonic Cone-Cylinder Aerodynamic Loads Study. Rept. LMSC/HREC A712618 (Contract NAS8-11289), Lockheed Missiles & Space Co., Nov. 30, 1965.
3. Margolis, Kenneth: Theoretical Evaluation of the Pressures, Forces, and Moments at Hypersonic Speeds Acting on Arbitrary Bodies of Revolution Undergoing Separate and Combined Angle-of-Attack and Pitching Moments. NASA TN D-652, 1961.