

NASA TECHNICAL NOTE



NASA TN D-4485

0.1

NASA TN D-4485



LOAN COPY: RETURN TO
AFWL (WLIL-2)
KIRTLAND AFB, N MEX

**A THEORETICAL APPROACH TO THE
DETERMINATION OF MAGNETIC TORQUES
BY NEAR FIELD MEASUREMENT**

by J. C. Boyle, J. Greyerbiehl, and E. J. Mosher

Goddard Space Flight Center

Greenbelt, Md.



NATIONAL AERONAUTICS AND SPACE ADMINISTRATION

WASHINGTON, D. C. MAY 1968



A THEORETICAL APPROACH TO THE DETERMINATION OF
MAGNETIC TORQUES BY NEAR FIELD MEASUREMENT

By J. C. Boyle, J. Greyerbiehl, and E. J. Mosher

Goddard Space Flight Center
Greenbelt, Md.

NATIONAL AERONAUTICS AND SPACE ADMINISTRATION

For sale by the Clearinghouse for Federal Scientific and Technical Information
Springfield, Virginia 22151 - CFSTI price \$3.00

ABSTRACT

Using the concept of stress in the medium as postulated by Faraday and developed mathematically by Maxwell and Jeans, equations are derived for the torque on a magnetic object immersed in an arbitrary magnetic field. The calculation requires a knowledge of the magnetic intensity vector over any closed surface which encompasses the magnetic object of interest.

Torque equations are derived for the case where the closed surface is a sphere of arbitrary radius and also where the closed surface is a right circular cylinder. The validity of the equations is tested by applying them to a simple intensity distribution (that of a theoretical dipole) where the resultant torque is known a priori. There is also a discussion of permanent versus induced moments and a technique which can be used to separately identify these components based on near field information.

CONTENTS

Abstract	ii
INTRODUCTION.	1
MATHEMATICAL APPROACH	1
ANALYSIS.	4
CONCLUSION	10
References	10
Appendix A—Determination of Dipole Moment	11
Appendix B—Application of Analysis	15
Appendix C—Symbol List	19

A THEORETICAL APPROACH TO THE DETERMINATION OF MAGNETIC TORQUES BY NEAR-FIELD MEASUREMENT

by

J. C. Boyle, J. Greyerbiehl, and E. J. Mosher
Goddard Space Flight Center

INTRODUCTION

Torques are produced on orbiting spacecraft by interaction between the magnetic field of the spacecraft and the ambient magnetic field. Such torques tend to alter the attitude of the spacecraft and are therefore important to the problem of attitude control. Since the torque depends on the active magnetic control elements as well as the permanent magnetic state and the permeability of all the spacecraft components, it is generally determined by measurements made on the completely assembled and integrated spacecraft.

Instruments have been developed for the direct measurement of spacecraft torques in pre-flight testing (Reference 1). It is not always desirable or even feasible to use this method, in which case torques must be calculated from magnetic measurements.

Magnetic torque may be defined as* $L = M \times H$. One way to find the magnetic moment M of an object is to take "far-field" magnetic measurements. This makes use of the fact that at large distances from the test object the field resembles that of an equivalent simple dipole, which is easy to calculate from field measurements. But when the test object is bulky (say, a large spacecraft) it may be necessary to retreat to such distances that the field of the spacecraft is weak, making the measurements unreliable. This circumstance has generated an interest in "near-field" measurements—made close enough to the spacecraft to be reliable, which is to say, too close to reduce the craft to an equivalent simple dipole. This report develops a mathematical approach for calculating torques using near field measurements.

MATHEMATICAL APPROACH

In classical magnetic studies by Maxwell, Faraday and Jeans, the calculation of forces due to electric or magnetic fields used the concept of tubes of stress. Observation of magnetic lines of

*For meaning of mathematical symbols refer to Appendix C.

force and their effect on material bodies led Faraday to believe that the lines tend to shorten themselves and repel one another when placed side by side. Maxwell (Reference 2) assumed the existence of a transmitting medium in a state of stress. Where no magnetization is present (as in air or vacuum), the stresses consist of a tension along the lines of force equal to $H^2/8\pi$ combined with a pressure in all directions at right angles to the lines of force, also equal to $H^2/8\pi$.

Although the concept of an all-pervading ether as a transmitting medium is now in considerable disrepute, Maxwell's mathematics is not, since it confirmed the numerical results of experimental observation and (incidentally) established the propagation of light as an electromagnetic phenomenon.

Sir James Jeans (Reference 3) uses the stress on a medium and Green's theorem to develop a set of equations defining electric torques on an assemblage of charges in an electric field. If it is true that the computation to determine the torque due to a magnetic body in a magnetic field is analogous to the electrical computation referred to above, then Jeans' equations (when written in their magnetic counterparts) will be valid for magnetic studies.

A practical near field magnetic survey is likely to be made over a sphere or cylinder; and, since Jeans' formulation is in rectangular coordinates, it is not particularly suitable. Instead of transforming Jeans' equations into other coordinate systems it was found easier to develop expressions directly from Maxwell's stress equations.

Using the mathematical approach developed for analyzing stresses in elastic solids, we obtain expressions for the interaction torque of a magnetic body in a magnetic field. The approach taken in this writing is outlined in the next two paragraphs.

Consider a free body of a continuous surface such as a sphere or cylinder, or even an irregular shape, completely surrounding a magnetic specimen. As an example, Figure 1 illustrates the octant of a sphere whose origin is located at the geometric center of the specimen. It is not necessary that the specimen be centered, this is a convenience only. The axes have been selected such that the ambient field, H_a , is parallel to the y -axis. At some general point P , on the sphere, the specimen creates a field H_s . These two fields combine to form the resultant H . Let us now look at the elemental area dS , described in the spherical coordinates r, θ, ϕ , as shown in Figure 2. Continuing to Figure 3, replace the field vector H , with a tensile stress vector κH^2 . Enclose the stress vector in a square tube of ether of unit width with one pair of sides parallel, and the other pair perpendicular to the plane containing the stress vector and the unit normal \hat{n} . Impose a compressive stress vector equal to κH^2 on each side of the tube. Establish the tube as a free body and determine the stress vector on dA necessary to maintain the tube in static equilibrium. This then determines the stress vector σ on the surface element of ether that will keep the element

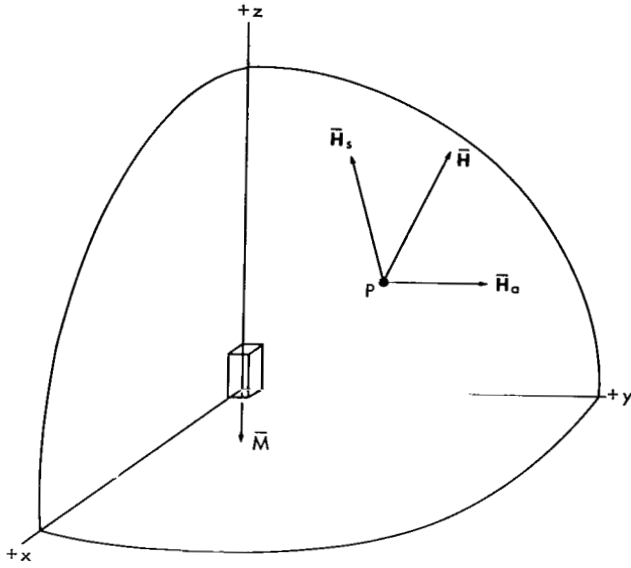

Figure 1—Vector representation of a magnetic specimen in a magnetic field.

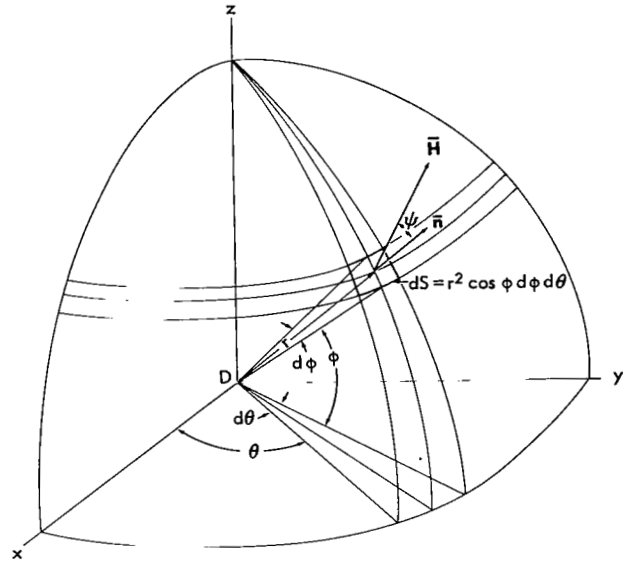

Figure 2—Orientation of intensity vector relative to an element of the surface.

stationary. It can be shown that this stress vector is in the same plane (a principal plane) as the unit normal \hat{n} and the tension vector and makes an angle of 2ψ with \hat{n} . The angle between σ and \hat{n} is bisected by H .

Knowing the stress vector in the ether, write the equation for the differential torque for an elemental surface using the appropriate spherical or cylindrical coordinates. Resolve the equation of torque to x , y , z components with the components still written in spherical or cylindrical coordinates. Integrate over the complete surface to find the expressions for the rectangular torque components. When the resultant expressions are tested for the case of a simple dipole in a magnetic field, the accepted expression

$$L = M \times H_o$$

is obtained.

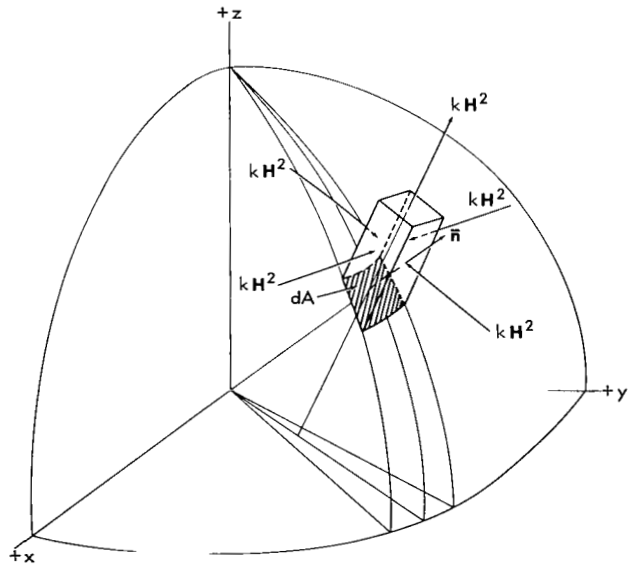

Figure 3—Magnetic stress on an element of the surrounding medium.

ANALYSIS

The square tube of ether shown in Figure 3 may be treated as a body in equilibrium under the action of external forces. If the tube is viewed so that the area dA is seen "edge on," the force picture is as shown in Figure 4.

Equilibrium requires the force on dA to have a vertical component equal to

$$kH^2 dA \cos \psi$$

and a horizontal component equal to

$$kH^2 dA \sin \psi .$$

In vector notation

$$dF = kH^2(\hat{H} \cdot dA)\hat{H} - kH^2(\hat{H} \times dA) \times \hat{H} \quad (1)$$

The stress on dA is then

$$\begin{aligned} \sigma &= \frac{dF}{|dA|} = \frac{kH^2(\hat{H} \cdot dA)\hat{H}}{|dA|} - \frac{kH^2(\hat{H} \times dA) \times \hat{H}}{|dA|} \\ \sigma &= kH^2(\hat{H} \cdot \hat{n})\hat{H} - kH^2(\hat{H} \cdot \hat{H}) \frac{dA}{|dA|} + \frac{kH^2(dA \cdot \hat{H})\hat{H}}{|dA|} \\ &= kH^2(\hat{H} \cdot \hat{n})\hat{H} - kH^2\hat{n} + kH^2(\hat{n} \cdot \hat{H})\hat{H} \\ &= 2kH^2(\hat{H} \cdot \hat{n})\hat{H} - kH^2\hat{n} . \end{aligned} \quad (2)$$

In general, the elementary area dA will not be oriented the same way as dS , which is the conventional elementary area based on an r, θ, ϕ spherical coordinate system and which is more convenient mathematically. Since we are dealing with the same stress in either case, we may now express the elementary force on dS as

$$df = \sigma dS .$$

The torque generated by each element of force is

$$dL = r \times df = r \times \sigma dS$$

$$dL = r \times [2kH^2(\hat{H} \cdot \hat{n})\hat{H} - kH^2\hat{n}] dS . \quad (3)$$

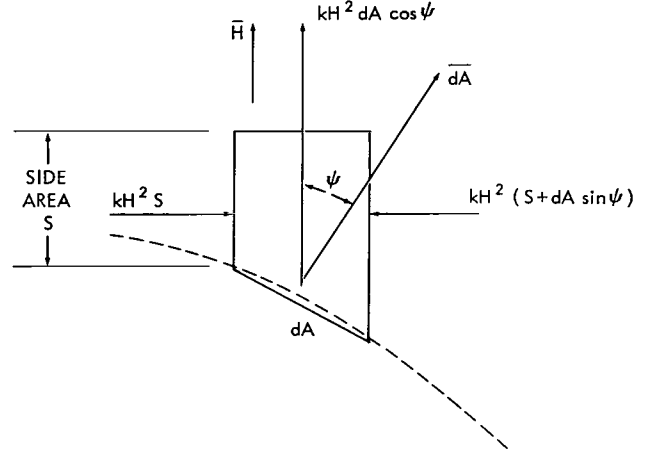

Figure 4—Equilibrium diagram of magnetic forces.

Expressing the vector torque equation in terms of a spherical coordinate system and recognizing that

$$H^2(\hat{\mathbf{H}} \cdot \hat{\mathbf{n}})\hat{\mathbf{H}} = |\mathbf{H}|^2 \left[\frac{\mathbf{H}}{|\mathbf{H}|} \cdot \hat{\mathbf{n}} \right] \frac{\mathbf{H}}{|\mathbf{H}|} = (\mathbf{H} \cdot \hat{\mathbf{n}})\mathbf{H}.$$

and that for a sphere $\hat{\mathbf{n}} = \hat{\mathbf{r}}$, then

$$d\mathbf{L} = (\mathbf{r} \times 2k(\mathbf{H} \cdot \hat{\mathbf{r}})\mathbf{H} - \mathbf{r} \times kH^2\hat{\mathbf{r}})dS.$$

Since the second term goes to zero, we obtain

$$d\mathbf{L} = (\mathbf{r} \times 2k(\mathbf{H} \cdot \hat{\mathbf{r}})\mathbf{H}) dS. \quad (4)$$

For a sphere of radius a

$$\mathbf{r} = a\hat{\mathbf{r}}$$

$$\mathbf{H} = H_r\hat{\mathbf{r}} + H_\theta\hat{\boldsymbol{\theta}} + H_\phi\hat{\boldsymbol{\phi}}$$

$$\mathbf{H} \cdot \hat{\mathbf{r}} = H_r$$

then

$$\begin{aligned} d\mathbf{L} &= (\mathbf{r} \times 2kH_r\mathbf{H}) dS \\ &= \left[a\hat{\mathbf{r}} \times (2kH_r^2\hat{\mathbf{r}} + 2kH_rH_\theta\hat{\boldsymbol{\theta}} + 2kH_rH_\phi\hat{\boldsymbol{\phi}}) \right] dS \\ &= (2akH_rH_\theta\hat{\boldsymbol{\phi}} - 2akH_rH_\phi\hat{\boldsymbol{\theta}}) dS. \end{aligned} \quad (5)$$

Resolving the torque into components along each of the Cartesian axes yields the desired result

$$dL_x = 2ak(H_rH_\phi \sin \theta - H_rH_\theta \sin \phi \cos \theta) dS \quad (6)$$

$$dL_y = -2ak(H_rH_\phi \cos \theta + H_rH_\theta \sin \theta \sin \phi) dS \quad (7)$$

$$dL_z = 2akH_rH_\theta \cos \phi dS. \quad (8)$$

Equations 6, 7, and 8 represent the elementary torque components along the three orthogonal axes in terms of the scalar field components and the associated angles expressed in spherical coordinates.

The stress in the medium is equal to $H^2/8\pi$, so that

$$k = \frac{1}{8\pi}.$$

Also, in the spherical coordinate system

$$dS = a^2 \cos \phi \, d\phi d\theta,$$

so that the torques may be finally written as*

$$L_x = \frac{a^3}{2\pi} \left[\int_{\theta=0}^{2\pi} \int_{\phi=0}^{\pi/2} H_r H_\phi \sin \theta \cos \phi \, d\phi d\theta - \int_{\theta=0}^{2\pi} \int_{\phi=0}^{\pi/2} H_r H_\theta \sin \phi \cos \phi \cos \theta \, d\phi d\theta \right] \quad (9)$$

$$L_y = -\frac{a^3}{2\pi} \left[\int_{\theta=0}^{2\pi} \int_{\phi=0}^{\pi/2} H_r H_\phi \cos \theta \cos \phi \, d\phi d\theta + \int_{\theta=0}^{2\pi} \int_{\phi=0}^{\pi/2} H_r H_\theta \sin \theta \sin \phi \cos \phi \, d\phi d\theta \right] \quad (10)$$

$$L_z = \frac{a^3}{2\pi} \int_{\theta=0}^{2\pi} \int_{\phi=0}^{\pi/2} H_r H_\theta \cos^2 \phi \, d\phi d\theta. \quad (11)$$

An alternate solution to the problem of determining a vector torque equation for near-field measurements may also be found by transforming Equation 3 into cylindrical coordinates.

Rewriting Equation 3:

$$dL = r \times [2kH^2 (\hat{H} \cdot \hat{n})\hat{H} - kH^2 \hat{n}] \, dS. \quad (3)$$

For the cylindrical portion of the enclosing volume, we have

$$r = \rho + z; \quad \hat{n} = \hat{\rho}; \quad \hat{H} = \frac{\mathbf{H}}{|\mathbf{H}|}.$$

Substituting the above relations in Equation 3 gives

$$dL = (\rho + z) \times \left[2kH^2 \left(\frac{\mathbf{H}}{|\mathbf{H}|} \cdot \hat{\rho} \right) \frac{\mathbf{H}}{|\mathbf{H}|} - kH^2 \hat{\rho} \right] dS,$$

$$dL = (\rho + z) \times [2k(\mathbf{H} \cdot \hat{\rho})\mathbf{H} - kH^2 \hat{\rho}] \, dS,$$

*The torques appear to be functions of the radius of the sphere; however, when the components of \mathbf{H} are evaluated it will be found that the torques are actually independent of the radius.

but

$$\mathbf{H} = H_\rho \hat{\rho} + H_\theta \hat{\theta} + H_z \hat{z}$$

and

$$\boldsymbol{\rho} = \rho \hat{\rho}; \quad \boldsymbol{\theta} = \theta \hat{\theta}; \quad \mathbf{z} = z \hat{z}.$$

Therefore

$$\begin{aligned} d\mathbf{L} &= (\boldsymbol{\rho} + \mathbf{z}) \times [2kH_\rho \mathbf{H} - kH^2 \hat{\rho}] dS, \\ d\mathbf{L} &= \rho (2kH_\rho H_\theta \hat{z} - 2kH_\rho H_z \hat{\theta}) dS + z (2kH_\rho^2 \hat{\theta} - 2kH_\rho H_\theta \hat{\rho} - kH^2 \hat{\theta}) dS, \\ d\mathbf{L} &= -2kzH_\rho H_\theta dS \hat{\rho} + (2kzH_\rho^2 - 2k\rho H_\rho H_z - kzH^2) dS \hat{\theta} + 2k\rho H_\rho H_\theta dS \hat{z}. \end{aligned} \quad (12)$$

Again resolving the torque equations into components along each of the Cartesian axes, yields

$$\begin{aligned} dL_x &= dL_\rho \cos \theta - dL_\theta \sin \theta, \\ dL_y &= dL_\rho \sin \theta + dL_\theta \cos \theta, \\ dL_z &= dL_z, \end{aligned}$$

or

$$\begin{aligned} dL_x &= -(2kzH_\rho H_\theta \cos \theta) dS - (2kzH_\rho^2 - 2k\rho H_\rho H_z - kzH^2) \sin \theta dS, \\ dL_y &= -(2kzH_\rho H_\theta \sin \theta) dS + (2kzH_\rho^2 - 2k\rho H_\rho H_z - kzH^2) \cos \theta dS, \\ dL_z &= 2k\rho H_\rho H_\theta dS. \end{aligned}$$

Therefore, we obtain for the cylindrical portion

$$dL_x = -2k \left[zH_\rho H_\theta \cos \theta + \left(zH_\rho^2 - \rho H_\rho H_z - \frac{zH^2}{2} \right) \sin \theta \right] dS, \quad (13)$$

$$dL_y = -2k \left[zH_\rho H_\theta \sin \theta - \left(zH_\rho^2 - \rho H_\rho H_z - \frac{zH^2}{2} \right) \cos \theta \right] dS, \quad (14)$$

$$dL_z = 2k\rho H_\rho H_\theta dS. \quad (15)$$

For the top surface of the cylinder,

$$\mathbf{r} = \boldsymbol{\rho} + \mathbf{z}; \quad \hat{\mathbf{n}} = \hat{z}; \quad \hat{\mathbf{H}} = \frac{\mathbf{H}}{|\mathbf{H}|}.$$

The torque expression for this surface may now be expressed as

$$d\mathbf{L} = \mathbf{r} \times [2k(\mathbf{H} \cdot \hat{\mathbf{n}})\mathbf{H} - kH^2\hat{\mathbf{n}}] dS ,$$

$$d\mathbf{L} = (\boldsymbol{\rho} + \mathbf{z}) \times [2kH_z\mathbf{H} - kH^2\hat{\mathbf{z}}] dS ,$$

$$d\mathbf{L} = -2kzH_\theta H_z dS\hat{\rho} + (kH^2\rho - 2k_\rho H_z^2 + 2kzH_\rho H_z) dS\hat{\theta} + 2k_\rho H_\theta H_z dS\hat{z} . \quad (16)$$

Resolving into components, we have

$$dL_x = -2k \left[zH_\theta H_z \cos \theta + \left(\frac{\rho H^2}{2} - \rho H_z^2 + zH_\rho H_z \right) \sin \theta \right] dS , \quad (17)$$

$$dL_y = -2k \left[zH_\theta H_z \sin \theta - \left(\frac{\rho H^2}{2} - \rho H_z^2 + zH_\rho H_z \right) \cos \theta \right] dS , \quad (18)$$

$$dL_z = 2k_\rho H_\theta H_z dS . \quad (19)$$

For the bottom surface of the cylinder

$$\mathbf{r} = \boldsymbol{\rho} + \mathbf{z}; \quad \hat{\mathbf{n}} = -\hat{\mathbf{z}}; \quad \hat{\mathbf{H}} = \frac{\mathbf{H}}{|\mathbf{H}|} ;$$

$$d\mathbf{L} = (\boldsymbol{\rho} + \mathbf{z}) \times [-2kH_z\mathbf{H} + kH^2\hat{\mathbf{z}}] dS ,$$

$$d\mathbf{L} = 2kzH_\theta H_z dS\hat{\rho} - (kH^2\rho - 2k_\rho H_z^2 + 2kzH_\rho H_z) (dS)\hat{\theta} - 2k_\rho H_\theta H_z dS\hat{z} . \quad (20)$$

Putting this into component form, we have

$$dL_x = 2k \left[zH_\theta H_z \cos \theta + \left(\frac{\rho H^2}{2} - \rho H_z^2 + zH_\rho H_z \right) \sin \theta \right] dS , \quad (21)$$

$$dL_y = 2k \left[zH_\theta H_z \sin \theta - \left(\frac{\rho H^2}{2} - \rho H_z^2 + zH_\rho H_z \right) \cos \theta \right] dS , \quad (22)$$

$$dL_z = -2k_\rho H_\theta H_z dS . \quad (23)$$

For top and bottom of the cylinder, the elementary area is

$$dS = \rho d\rho d\theta .$$

For the cylindrical portion

$$dS = a d\theta dz .$$

Integrating and adding the torques for the three surfaces of the cylinder yields

$$\begin{aligned}
L_x = & -\frac{a}{4\pi} \left[\int_{z=-z_0}^{+z_0} \int_{\theta=0}^{2\pi} H_\rho H_\theta z \cos \theta d\theta dz + \int_{z=-z_0}^{+z_0} \int_{\theta=0}^{2\pi} \left(H_\rho^2 z - \rho H_\rho H_z - \frac{zH_z^2}{2} \right) \sin \theta d\theta dz \right] \\
& - \frac{1}{4\pi} \left[\int_{\rho=0}^a \int_{\theta=0}^{2\pi} z_0 H_\theta H_z (\cos \theta) \rho d\rho d\theta + \int_{\rho=0}^a \int_{\theta=0}^{2\pi} \left(\frac{\rho H_\rho^2}{2} - \rho H_z^2 + z_0 H_\rho H_z \right) (\sin \theta) \rho d\rho d\theta \right] \\
& + \frac{1}{4\pi} \left[\int_{\rho=0}^a \int_{\theta=0}^{2\pi} -z_0 H_\theta H_z (\cos \theta) \rho d\rho d\theta + \int_{\rho=0}^a \int_{\theta=0}^{2\pi} \left(\frac{\rho H_\rho^2}{2} - \rho H_z^2 + (-z_0) H_\rho H_z \right) (\sin \theta) \rho d\rho d\theta \right].
\end{aligned}$$

Since

$$H^2 = H_\rho^2 + H_\theta^2 + H_z^2,$$

we have

$$\begin{aligned}
L_x = & -\frac{a}{4\pi} \left[\int_{z=-z_0}^{+z_0} \int_{\theta=0}^{2\pi} H_\rho H_\theta z \cos \theta d\theta dz + \int_{z=-z_0}^{+z_0} \int_{\theta=0}^{2\pi} \left(\frac{H_\rho^2 z}{2} - \rho H_\rho H_z - \frac{zH_\theta^2}{2} - \frac{zH_z^2}{2} \right) \sin \theta d\theta dz \right] \\
& - \frac{1}{4\pi} \left[\int_{\rho=0}^a \int_{\theta=0}^{2\pi} z_0 H_\theta H_z (\cos \theta) \rho d\rho d\theta + \int_{\rho=0}^a \int_{\theta=0}^{2\pi} \left(\frac{\rho H_\rho^2}{2} + \frac{\rho H_\theta^2}{2} - \frac{\rho H_z^2}{2} + z_0 H_\rho H_z \right) (\sin \theta) \rho d\rho d\theta \right] \\
& + \frac{1}{4\pi} \left[\int_{\rho=0}^a \int_{\theta=0}^{2\pi} -z_0 H_\theta H_z (\cos \theta) \rho d\rho d\theta + \int_{\rho=0}^a \int_{\theta=0}^{2\pi} \left(\frac{\rho H_\rho^2}{2} + \frac{\rho H_\theta^2}{2} - \frac{\rho H_z^2}{2} - z_0 H_\rho H_z \right) (\sin \theta) \rho d\rho d\theta \right]. \quad (24)
\end{aligned}$$

$$\begin{aligned}
L_y = & -\frac{a}{4\pi} \left[\int_{z=-z_0}^{+z_0} \int_{\theta=0}^{2\pi} z H_\rho H_\theta \sin \theta d\theta dz - \int_{z=-z_0}^{+z_0} \int_{\theta=0}^{2\pi} \left(\frac{zH_\rho^2}{2} - a H_\rho H_z - \frac{zH_\theta^2}{2} - \frac{zH_z^2}{2} \right) \cos \theta d\theta dz \right] \\
& - \frac{1}{4\pi} \left[\int_{\rho=0}^a \int_{\theta=0}^{2\pi} z_0 H_\theta H_z (\sin \theta) \rho d\rho d\theta - \int_{\rho=0}^a \int_{\theta=0}^{2\pi} \left(\frac{\rho H_\rho^2}{2} + \frac{\rho H_\theta^2}{2} - \frac{\rho H_z^2}{2} + z_0 H_\rho H_z \right) (\cos \theta) \rho d\rho d\theta \right] \\
& + \frac{1}{4\pi} \left[\int_{\rho=0}^a \int_{\theta=0}^{2\pi} -z_0 H_\theta H_z (\sin \theta) \rho d\rho d\theta - \int_{\rho=0}^a \int_{\theta=0}^{2\pi} \left(\frac{\rho H_\rho^2}{2} + \frac{\rho H_\theta^2}{2} - \frac{\rho H_z^2}{2} - z_0 H_\rho H_z \right) (\cos \theta) \rho d\rho d\theta \right]. \quad (25)
\end{aligned}$$

$$L_z = \frac{a^2}{4\pi} \int_{z=-z_0}^{+z_0} \int_{\theta=0}^{2\pi} H_\rho H_\theta d\theta dz + \frac{1}{4\pi} \int_{\rho=0}^a \int_{\theta=0}^{2\pi} \rho H_\theta H_z \rho d\rho d\theta - \frac{1}{4\pi} \int_{\rho=0}^a \int_{\theta=0}^{2\pi} \rho H_\theta H_z \rho d\rho d\theta . \quad (26)$$

It should be noted that the components of the torque in the x , y , z directions for the top and bottom surfaces do not cancel each other but depend on the limits of integration chosen for the volume.

To illustrate the use of the equations in a sample problem, a simple dipole is placed in a uniform magnetic field with the dipole axis normal to the field (see Appendix B). With spherical coordinates, the resultant torque on the dipole is then calculated and found to agree with the accepted expression $\mathbf{L} = \mathbf{M} \times \mathbf{H}_a$.

Further verification may be obtained by placing a representative test body in a magnetic coil facility in which the external field may be accurately controlled. The torques calculated from magnetic measurements then may be compared with direct torque measurements.

CONCLUSION

Equations 9, 10, and 11 for the spherical case and 24, 25, and 26 for the cylindrical case permit us to calculate the components of magnetic interaction torque from near-field measurements. The expressions derived are quite general. It is not necessary that the enclosing surface be centered with respect to the body being tested. Also, the ambient field has no restrictions as to uniformity.

Goddard Space Flight Center
National Aeronautics and Space Administration
Greenbelt, Maryland, November 20, 1967
039-02-01-10-51

REFERENCES

1. Boyle, J. C. and Greyerbiehl, J. M. "A Method for the Measurement of Extremely Feeble Torques On Massive Bodies." NASA TN D-3711.
2. Maxwell, James Clerk, "A Treatise on Electricity and Magnetism," New York: Dover Publications, 1954.
3. Jeans, J. H., "The Mathematical Theory of Electricity and Magnetism," New York: Cambridge University Press, 1920.
4. Moscowitz, R. and Lynch, R. "Magnetostatic Measurement of Spacecraft Magnetic Dipole Moment" IEEE Transactions on Aerospace Vol. 2 No. 2, Apr. 64.

Appendix A

Determination of Dipole Moment

If we are interested in the components of dipole moment of the spacecraft, both permanent and induced, we may determine them from the torques by the following procedure:

In general, if three components of external field are applied, we have

$$L_x = M_y H_{az} - M_z H_{ay} , \quad (27)$$

$$L_y = M_z H_{ax} - M_x H_{az} , \quad (28)$$

$$L_z = M_x H_{ay} - M_y H_{ax} . \quad (29)$$

At first glance it seems that the above equations will suffice to find M_x , M_y , and M_z . This turns out not to be the case, since the determinant of the coefficients vanishes. This difficulty is overcome by making two measurements. For example, if we apply the external field parallel to the positive x-axis, we obtain

$$H_{ay} = H_{az} = 0$$

so that Equations 27, 28, and 29 reduce to

$$L_x = 0 ,$$

$$L_y = M_z H_{ax} , \quad (30)$$

$$L_z = -M_y H_{ax} . \quad (31)$$

Equations 30 and 31 yield values for M_y and M_z . If now the field is applied along the y-axis,

$$H_{ax} = H_{az} = 0 ,$$

$$L_x = -M_z H_{ay} , \quad (32)$$

$$\begin{aligned}
L_y &= 0, \\
L_z &= M_x H_{ay},
\end{aligned}
\tag{33}$$

and M_x may now be determined from Equation 33.

The above would suffice if there were no induced moment. If an induced moment is present,

$$\begin{aligned}
M_x &= M_{xp} + M_{xi}, \\
M_y &= M_{yp} + M_{yi}, \\
M_z &= M_{zp} + M_{zi}.
\end{aligned}$$

Equations 30 through 33 may be rewritten as

$$\begin{aligned}
L_y &= (M_{zp} + M_{zi}) H_{ax} \\
L_z &= -(M_{yp} + M_{yi}) H_{ax} \\
L_x &= -(M_{zp} + M_{zi}) H_{ay} \\
L_z &= (M_{xp} + M_{xi}) H_{ay}.
\end{aligned}$$

Now it is known that the induced moment will reverse if the applied field is reversed while the permanent moment will not. The equations which represent this are

$$\begin{aligned}
L'_y &= -(M_{zp} - M_{zi}) H_{ax}, \\
L'_z &= (M_{yp} - M_{yi}) H_{ax}, \\
L'_x &= (M_{zp} - M_{zi}) H_{ay}, \\
L'_z &= -(M_{xp} - M_{xi}) H_{ay}.
\end{aligned}$$

Solving the last two sets of equations simultaneously yields for the permanent moment components

$$M_{xp} = \frac{L_z - L'_z}{2H_{ay}}, \tag{34}$$

$$M_{yp} = \frac{L'_z - L_z}{2H_{ax}}, \tag{35}$$

$$M_{z p} = \frac{L_y - L'_y}{2H_{ax}}, \quad (36)$$

and for the induced moment due to H_{ax} , where $H_{ay} = H_{az} = 0$,

$$M_{y i} = \frac{L_z + L'_z}{2H_{ax}}, \quad (37)$$

$$M_{z i} = \frac{L_y + L'_y}{2H_{ax}}. \quad (38)$$

Similarly, for the induced moment due to H_{ay} , where $H_{az} = H_{ax} = 0$,

$$M_{x i} = \frac{L_z + L'_z}{2H_{ay}}, \quad (39)$$

$$M_{z i} = \frac{-L_x + L'_x}{2H_{ay}}. \quad (40)$$

Equations 34, 35, and 36 completely define the magnetic moment due to the permanent magnetism present. No such unique definition is possible in the case of the induced magnetism, since this moment depends on the applied field vector. Equations 37 and 38 and Equations 39 and 40 define the torque-producing components of the induced magnetism for fields applied in the x and y directions, respectively. Similar expressions may also be obtained for the components due to a field applied in the Z direction.

From the above it is evident that equivalent dipole determination by the method described above involves much computation. At least four sets of magnetic field readings must be made for each element of surface over which the integration is to be performed.

An alternative method involving integration of only the radial field component taken over a spherical surface is presented in Reference 4.

Appendix B

Application of Analysis

From Equations (6), (7), and (8) derived in the "Analysis" section, we may obtain the interaction torque for a simple dipole placed into a previously uniform magnetic field. Choosing a dipole whose axis is along the z -axis and knowing that the total vector field is composed of both the ambient field, H_a and the field due to the dipole H_d we may write

$$\mathbf{H} = \mathbf{H}_a + \mathbf{H}_d$$

where

$$\mathbf{H}_a = H_a \hat{y} \text{ (along the + Y axis)}$$

and

$$H_{ar} = H_a \sin \theta \cos \phi$$

$$H_{a\theta} = H_a \cos \theta$$

$$H_{a\phi} = -H_a \sin \theta \sin \phi.$$

Therefore, the ambient field vector is

$$\mathbf{H}_a = H_a (\sin \theta \cos \phi) \hat{r} + H_a (\cos \theta) \hat{\theta} - H_a (\sin \theta \sin \phi) \hat{\phi}$$

The dipole field vector may be expressed as the gradient of a scalar

$$\mathbf{H}_d = -\nabla V$$

where

$$V = \frac{\mathbf{M} \cdot \mathbf{r}}{r^3}$$

and

$$\mathbf{M} = -M\mathbf{k} \text{ (along the -z axis).}$$

The components of the dipole moment in spherical coordinates are then

$$M_r = -M \sin \phi ,$$

$$M_\theta = 0 ,$$

$$M_\phi = -M \cos \phi ,$$

or

$$\mathbf{M} = -M (\sin \phi) \hat{r} - M (\cos \phi) \hat{\phi} ,$$

$$\mathbf{r} = r \hat{r} ,$$

$$\mathbf{M} \cdot \mathbf{r} = -Mr \sin \phi ,$$

Therefore we may write

$$V = -\frac{M \sin \phi}{r^2}$$

also

$$\mathbf{H}_d = -\nabla V = -\frac{2M \sin \phi}{r^3} \hat{r} + \frac{M \cos \phi}{r^3} \hat{\phi} .$$

Adding \mathbf{H}_a and \mathbf{H}_d we obtain

$$\mathbf{H} = \left(H_a (\sin \theta) \cos \phi - \frac{2M \sin \phi}{r^3} \right) \hat{r} + H_a (\cos \theta) \hat{\theta} + \left(\frac{M \cos \phi}{r^3} - H_a \sin \theta \sin \phi \right) \hat{\phi} \quad (41)$$

Rewriting Equation 6 we have

$$dL_x = 2ak (H_r H_\phi \sin \theta - H_r H_\theta \sin \phi \cos \theta) dS$$

where H_r , H_θ , and H_ϕ are the components along the r , θ , and ϕ directions in Equation 41.

Combining Equations 6 and 41, we obtain

$$dL_x = 2ak \left\{ \left[-H_a^2 \sin^3 \theta \sin \phi \cos \phi + \frac{2MH_a \sin^2 \theta \sin^2 \phi}{r^3} + \frac{MH_a \sin^2 \theta \cos^2 \phi}{r^3} - \frac{2M^2 \sin \theta \sin \phi \cos \phi}{r^6} \right] dS - \left[H_a^2 \sin \theta \cos^2 \theta \sin \phi \cos \phi - \frac{2MH_a \cos^2 \theta \sin^2 \phi}{r^3} \right] dS \right\} .$$

In spherical coordinates

$$dS = a^2 \cos \phi \, d\theta d\phi .$$

Making this substitution,

$$L_x = 4a^3 k \left\{ \int_{\theta=0}^{2\pi} \int_{\phi=0}^{\pi/2} \left[-H_a^2 \sin^3 \theta \sin \phi \cos^2 \phi + \frac{2MH_a \sin^2 \theta \sin^2 \phi \cos \phi}{a^3} + \frac{MH_a \sin^2 \theta \cos^3 \phi}{a^3} \right. \right. \\ \left. \left. - \frac{2M^2 \sin \theta \sin \phi \cos^2 \phi}{a^6} - H_a^2 \sin \theta \cos^2 \theta \sin \phi \cos^2 \phi + \frac{2MH_a \cos^2 \theta \sin^2 \phi \cos \phi}{a^3} \right] d\theta d\phi \right\} .$$

Integrating term by term yields

$$L_x = 0 + \frac{8\pi}{3} kMH_a + \frac{8\pi}{3} kMH_a + 0 + 0 + \frac{8\pi}{3} kMH_a \\ = 8\pi kMH_a .$$

But $k = 1/8\pi$, so that

$$L_x = MH_a .$$

Similarly, from Equations 7 and 41:

$$dL_y = -2a^3 k \left[-H_a^2 \sin^2 \theta \cos \theta \sin \phi \cos^2 \phi + \frac{2MH_a \sin \theta \cos \theta \sin^2 \phi \cos \phi}{a^3} \right. \\ + \frac{MH_a \sin \theta \cos \theta \cos^3 \phi}{a^3} - \frac{2M^2 \cos \theta \sin \phi \cos^2 \phi}{a^6} \\ \left. + H_a^2 \sin^2 \theta \cos \theta \sin \phi \cos^2 \phi - \frac{2MH_a \sin \theta \cos \theta \sin^2 \phi \cos \phi}{a^3} \right] d\phi d\theta .$$

From which,

$$L_y = 0 .$$

From Equations 8 and 41:

$$dL_z = 2a^3 k \cos^2 \phi \left[H_a^2 \sin \theta \cos \theta \cos \phi - \frac{2MH_a \sin \phi \cos \theta}{a^3} \right] d\phi d\theta .$$

From which

$$L_z = 0 .$$

Thus the above analysis shows that Equations 6, 7, and 8 give the correct result when applied to a simple dipole in a uniform magnetic field. Equations 13, 14, and 15 for the curved portion of the cylinder, Equations 17 through 19, and 21 through 23, for the flat portion, have likewise been tested for the case of a simple dipole in a uniform field. The analysis is lengthy and is not presented here; however, the correct result was obtained in this case also.

Appendix C

Symbol List

a	fixed radius
k	constant
\hat{n}	normal unit vector
r	variable radius of r, θ, ϕ coordinate system
x, y, z	rectangular coordinates
B	magnetic induction
H	magnetic intensity
L	torque
M	magnetic moment
V	potential function
df	force on element dS
dA	element of area as defined on Figure 3
dF	force on element dA
dS	element of area as defined on Figure 2
θ, ϕ	spherical coordinates as defined on Figure 2
ψ	angle defined on Figure 2
ρ, θ, z	cylindrical coordinates
σ	stress

Subscripts

a	ambient
d	dipole
i	induced
p	permanent
s	specimen
x, y, z, r, ρ, θ, ϕ	coordinate system directions

FIRST CLASS MAIL

040 001 40 51 305 68120 00903
AIR FORCE WEAPONS LABORATORY/AFRL/7
WRIGHT AIR FORCE BASE, OHIO MEXICO 8711

RECEIVED
MAY 19 1958

POSTMASTER: If Undeliverable (Section 158
Postal Manual) Do Not Return

"The aeronautical and space activities of the United States shall be conducted so as to contribute . . . to the expansion of human knowledge of phenomena in the atmosphere and space. The Administration shall provide for the widest practicable and appropriate dissemination of information concerning its activities and the results thereof."

—NATIONAL AERONAUTICS AND SPACE ACT OF 1958

NASA SCIENTIFIC AND TECHNICAL PUBLICATIONS

TECHNICAL REPORTS: Scientific and technical information considered important, complete, and a lasting contribution to existing knowledge.

TECHNICAL NOTES: Information less broad in scope but nevertheless of importance as a contribution to existing knowledge.

TECHNICAL MEMORANDUMS: Information receiving limited distribution because of preliminary data, security classification, or other reasons.

CONTRACTOR REPORTS: Scientific and technical information generated under a NASA contract or grant and considered an important contribution to existing knowledge.

TECHNICAL TRANSLATIONS: Information published in a foreign language considered to merit NASA distribution in English.

SPECIAL PUBLICATIONS: Information derived from or of value to NASA activities. Publications include conference proceedings, monographs, data compilations, handbooks, sourcebooks, and special bibliographies.

TECHNOLOGY UTILIZATION PUBLICATIONS: Information on technology used by NASA that may be of particular interest in commercial and other non-aerospace applications. Publications include Tech Briefs, Technology Utilization Reports and Notes, and Technology Surveys.

Details on the availability of these publications may be obtained from:

**SCIENTIFIC AND TECHNICAL INFORMATION DIVISION
NATIONAL AERONAUTICS AND SPACE ADMINISTRATION
Washington, D.C. 20546**