

FACILITY FORM 802	N 68-28157	
	(ACCESSION NUMBER)	(THRU)
	15 (PAGES)	1 (CODE)
	TMX-59064 (NASA CR OR TMX OR AD NUMBER)	05 (CATEGORY)

GPO PRICE \$ _____
 CFSTI PRICE(S) \$ _____

Hard copy (HC) 300
 Microfiche (MF) 65

653 July 65

CHANGES IN PERCEIVED SIZE AND SHAPE
 OF A HIGHLY LUMINOUS TARGET

Richard F. Haines*
 Ames Research Center, NASA, Moffett Field, California

INTRODUCTION

Several visual phenomena associated with environments including high luminance photic sources have been reported: (a) changes in color,¹⁻³ (b) brightness reversals,¹ (c) changes in target size (irradiation phenomenon),⁴⁻⁸ (d) changes in target shape,⁴⁻⁶ and (e) impairment of visibility in adjacent visual areas.⁹⁻¹² Many of the studies deal with more subjective and personalistic aspects of such environments.¹³⁻¹⁹

When one steadily fixates on a very bright object against an unilluminated background, a number of events occur which must be considered when analyzing the observer's response(s). The more important can be listed: (1) optical effects (e.g., reflection, refraction, absorption, scattering in and near the eye), (2) photochemical effects, (3) visual effects (e.g., raised threshold, altered color perceptions, reduced pupil diameter, accommodative changes, etc.), and (4) subjective effects (e.g., discomfort, veiling glare, halos, Mach bands, color changes, blurred images, etc.). These effects are well documented in the literature; no insurmountable problems appear to exist in trying to explain or relate them. What needs to be done, however, is to relate such visual environments to subsequent subjective experiences. The subject of this paper is the quantification of perceived changes in size and shape of a very bright target, and their relation to associated stimuli.

In the following discussion the word boundary refers to the physical target, and edge refers to the perceived termination of the target with its surrounds. Likewise, the word form refers to the physical configuration of boundaries, and shape refers to the perceived configuration.

The stimulus configuration of interest here is a "natural pupil limited" pencil of high luminance heterochromatic photic flux impinging upon one retina (dominant eye) of observers (0) having 20:20 vision and focused for infinity. Several questions arise: First, does the fixated-bright target tend to change in perceived size as suggested in previous

*National Academy of Sciences, Postdoctoral Research Associate.

studies using less bright targets (the "irradiation phenomenon");⁴⁻⁶ second, does the target tend to change in perceived shape as one might expect on the basis of diffraction effects at the pupil,²⁰ retinal image motion, and other evidence?²¹ These questions can be answered by using the following psychophysical technique and apparatus.

METHOD

The following variables were investigated in the series of studies reported here: (1) target luminance, (2) target form, (3) target size, and (4) fixation position.

Apparatus

Figure 1 illustrates the facility used. The observer's eye (E) viewed the target (T) against an unilluminated background. The target

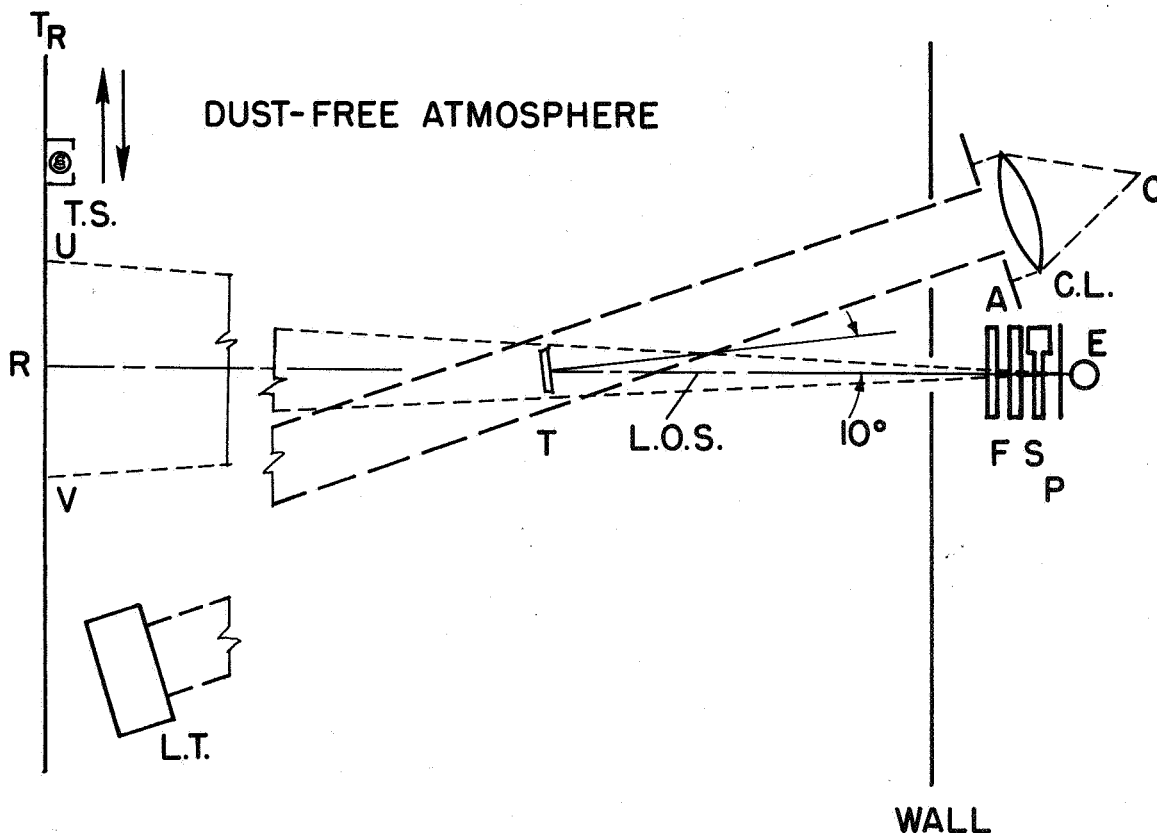

Fig. 1.- Diagram of facility.

was illuminated by a carbon-arc (C) solar simulator (5800°K) closely approximating the solar radiation curve outside the earth's atmosphere; it had an integrated radiant energy of approximately 1760 W/M². This photic radiation was passed through a collimating lens (C.L.) and reduced

by an aperture plate (A) to a diameter just exceeding that of the target. The photic radiation that slipped past T was captured by a light trap (L.T.). Since all of the apparatus except the photic source and O were in a clean room (class 10 000), backscattering from dust particles was negligible; this arrangement provided possibly the highest contrast and edge definition attainable in the laboratory situation. Neutral density Inconel filters (F) were used to vary target and test spot (T.S.) luminance and to reduce ultraviolet and infrared radiation. A tape controlled shutter (S) allowed precise repetition of trial intervals. An artificial pupil (P) was used to reduce the field of view to 6° in diameter and yet allow the natural pupil to function as the limiting aperture. The pupil also reduced scatter within the sclera. The artificial pupil (4 mm in diameter) was accurately centered on the natural pupil by means of an adjustable biting board.

The targets, milled steel plates with 20° back beveled edges, were coated with MgO to a thickness of at least 0.125 in. prior to testing. The square target was 0.88 in. on a side and 0.25 in. thick. The circular target was 4.00 in. in diameter and 0.25 in. thick. Each target was accurately mounted so that the line of sight (L.O.S.) from the eye through the exact center of the target would fall at the center of rotation (R) of a servocontrolled track-carriage assembly (Tr). Since this track was always rotated in a plane perpendicular to the L.O.S., any meridian of interest could be studied. (A meridian is the path taken by the T.S.) In the first study eight meridians, each 45° apart, were investigated for a square target. In the remaining studies only the horizontal (90° - 270°) meridian was studied.

On every trial, except for the unilluminated target (control) condition, radiant energy was measured at the corneal plane with a silicon PN type photodiode and field effect transistor.²²

A 1900°K point source (test spot, T.S.) was mounted on the movable carriage. It subtended $0^\circ 03' 54''$ and traveled at a constant velocity of $0^\circ 08' 20''$ per sec for all studies reported here (see arrows in Fig. 1 for T.S. direction). Its tungsten filament (1-1/2 V, 30 mA) produced a luminous intensity of 160 mlm.

The T.S. was used by each observer (O) to delineate the "apparent" halo surrounding (T) at various luminances. This was done by having the observer (O) fixate the appropriate location (experimental variable) and move a spring toggle switch which caused the T.S. either to approach or recede from the target. The observer was instructed to stop the T.S. immediately after it disappeared (IN trial) or reappeared (OUT trial). Since apparent target diameter was of interest, both sides of the target were "plotted" using the method of limits, i.e., the mean of many IN and OUT trials for each side of the target. There is evidence that this technique effectively cancels several types of response error.²³⁻²⁵ Further description of this technique can be found in Ref. 5.

In Fig. 1, U and V are the "eclipse" points of the T.S. caused by the target. If the T.S. were seen in this region, there must have been diffraction of the T.S. photic radiation at the target's boundary.

Observers

In the first and fourth studies two highly trained male observers were used (JP and EC). In the second study, the author served as the observer and, in the third study, JP, again served as the observer. One observer (RH) had 20:20 corrected vision while the other two observers had 20:15 and 20:20 uncorrected vision. Complete ophthalmological examinations were given before and after these studies.

Miscellaneous

All means shown on the following figures and used in calculations are based upon 52 IN-OUT trials. An average testing session lasted 2 h. Order of target luminance and T.S. meridian was randomized within blocks of IN and OUT trials to preclude possible order effects. An alert tone (900 cps) sounded 1/2 sec before the stimulus onset. The total trial time was 30 sec. To stabilize pupillary area, the observer waited at least 10 sec after the shutter opened before making his setting.

The retinal area stimulated by the target was assumed to be continually alternating between a state of light and dark adaptation due to the short periods of viewing and not viewing. The present light-dark-light (etc.) conditions would produce retinal adaptation changes best described by a sawtoothed negatively accelerating curve. It was also assumed that after about four trials the light adaptation level reached was essentially complete, i.e., adaptation fluctuations would be minimal thereafter.²⁶

RESULTS

Figures 2 and 3 present the results of the first study in which eight meridians and four target luminances were investigated. It is apparent that target size and shape are not functions of luminance when the contrast ratio of a T.S. and target does not change.* In general, the straight portions of the edge tended to contribute relatively more irradiation than the corners; to all observers the brighter targets appeared slightly rounded.

For all remaining figures, any data point lying above the horizontal (control) line represents the irradiation phenomenon. This line represents the visual angle subtended by the unilluminated edge; it corresponds closely with the actual boundary.** Each data point is tabulated with plus or minus one standard deviation. The target as seen by the observer is shown schematically in the upper portion of each figure with the irradiation region shaded.

*Neutral filters positioned between the eye and the target reduced T.S. and target luminance by the same amount.

**Diffraction effects account for the slight deviations between the two plots.

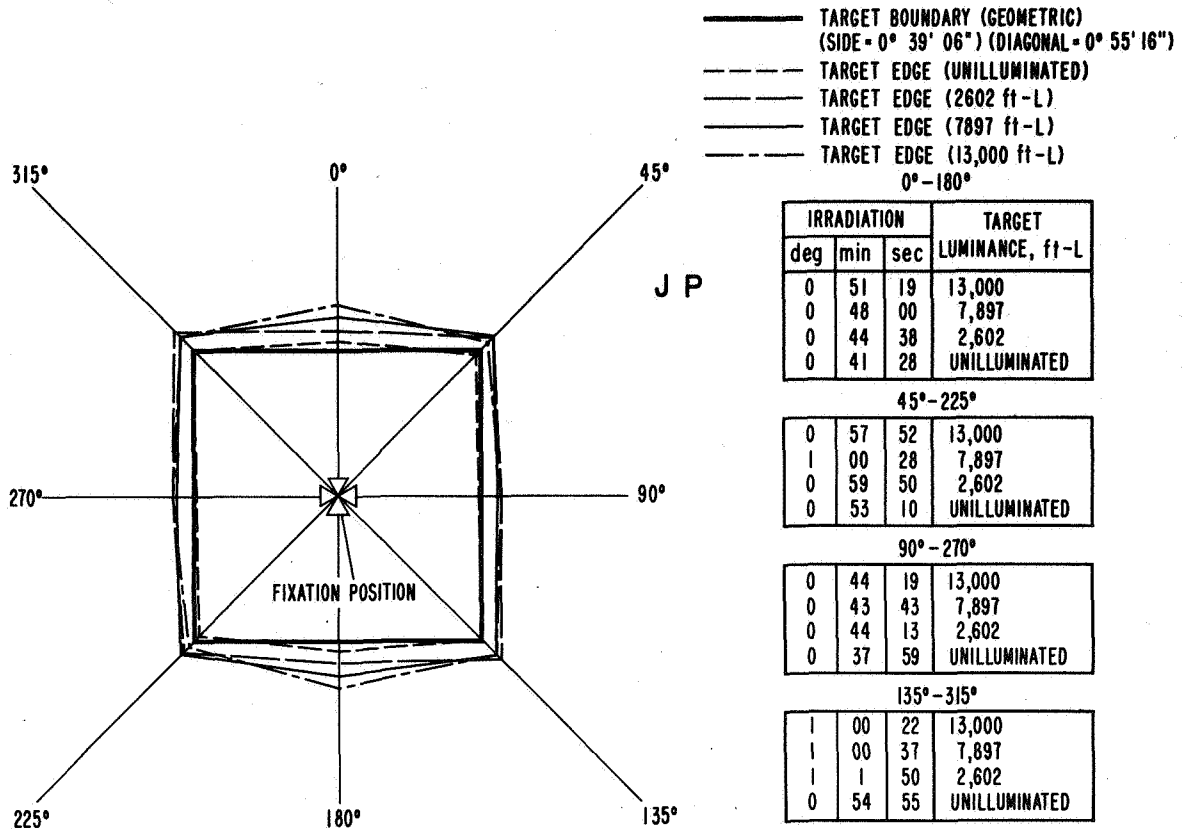

Fig. 2.- Results of the first study for observer JP.

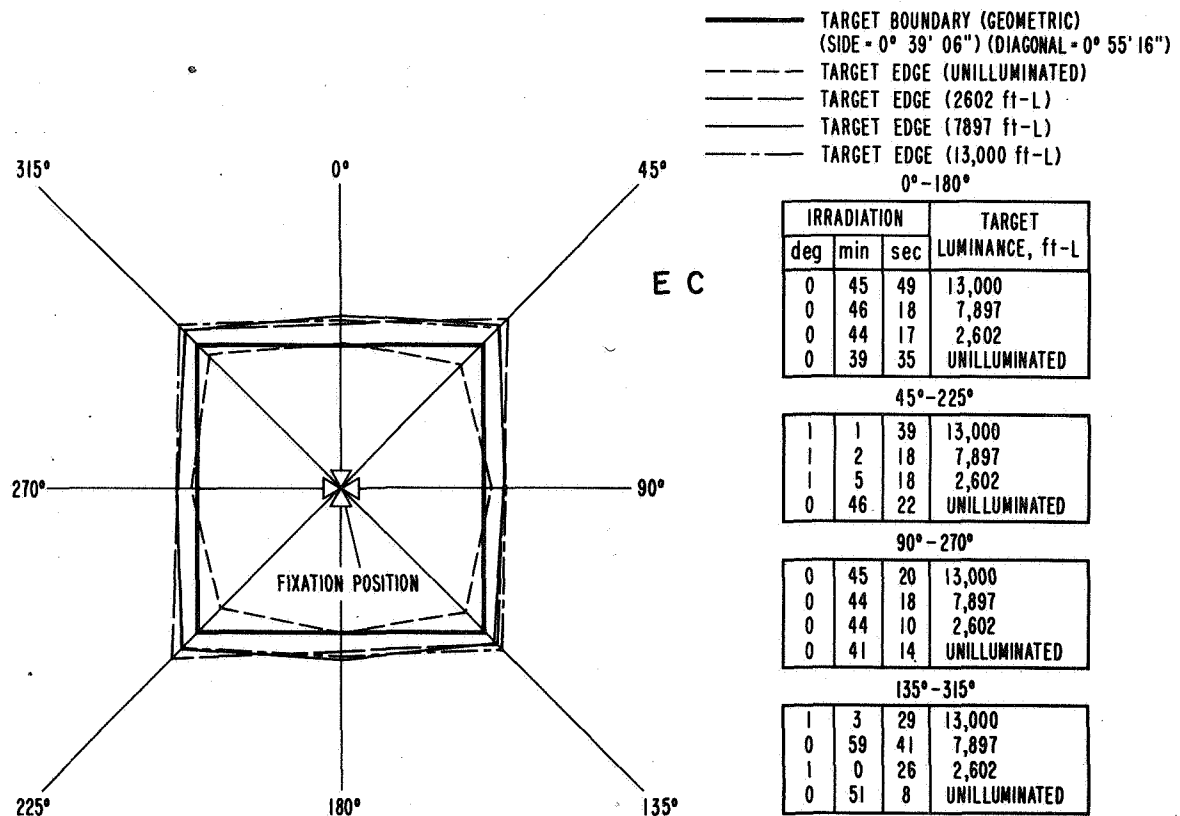

Fig. 3.- Results of the first study for observer EC.

The results from the second study are shown in Fig. 4. Six target luminances (A through F) and an unilluminated control (G) were investigated for a single (90° - 270°) meridian to quantify changes in target width. The irradiation effect yielded magnitudes up to almost $17'$ arc.

The results of the third study are shown in Fig. 5. The observer fixated either the target center (W through Z) or the T.S. (A through D).

Note that on each T.S. fixation trial the retinal image of the target sweeps across an area dependent upon the starting position of the T.S. for that trial. This starting position was randomly varied on each trial within a region which ranged from $45'$ to $1-1/4^{\circ}$ arc from the edge. Irradiation magnitudes up to $10'$ arc were found (see data points A through E).

Figures 6 and 7 present the results from the fourth study for two observers. In each figure, the magnitude of irradiation is relatively constant for all the target luminances. As can be seen in Figs. 6 and 7 relatively little irradiation was produced by the highest luminance and parafoveal target for both observers.

DISCUSSION

Purely on the basis of physical optics it can be said that if the T.S. is outside of points (U) and (V) in Fig. 1 (i.e., outside of the shaded region) and is not perceived, the contrast ratio between it and the immediate surround is zero. The essential question then becomes, at what location in the visual field surrounding a very bright target does this contrast ratio become zero? This question formed the basis for the present methodology, the results of which located this zero contrast region.

In the present study, the very high photic energy is not confined to the retinal image of the target but forms a tapered distribution due to entoptic scattering.²⁷⁻²⁹ Figure 8 is a frontal view photograph of three different target forms (left to right: circle, square, triangle) of high luminance ($10\ 000$ ft-L) that illustrates approximately what all observers said they saw.

The entoptic scatter leads to other considerations which are diagrammed below. Figure 9, a plot of the photic energy distribution on the retina with and without scatter (produced by an extended target), shows that the sensation curve* (points α , β , γ , δ , and ϵ) does not correspond to the retinal energy distribution, but rather it defines the resultant visibility curve for a given T.S. luminance. Presumably, it takes into account entoptic stray light and neural interaction effects. If the target is symmetrical, $\gamma - \gamma$ represents the half-width of the target. The luminance at the target center is represented by A_1 . Figure 9 is adapted from Refs. 30 and 32.

Since the retinal image of the target was not stabilized, it fell upon a larger number of cones than it would otherwise.³⁰ Electrooculograms (E.O.G.) were recorded during testing to assess the magnitude of eyeglobe motions. Their average magnitude was under $20'$ arc, the best resolution

*The well-known curve is associated with Mach band effects; a discussion of them can be found in Refs. 30 and 31.

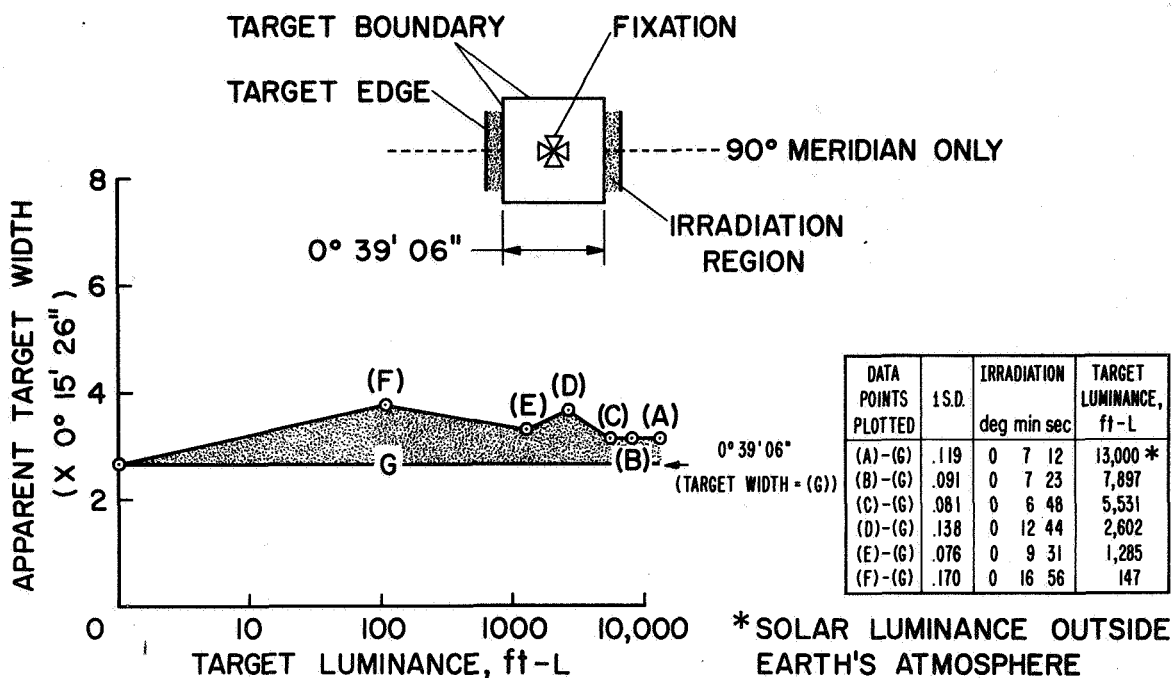

Fig. 4.- The effect of target luminance upon apparent target width (irradiation).

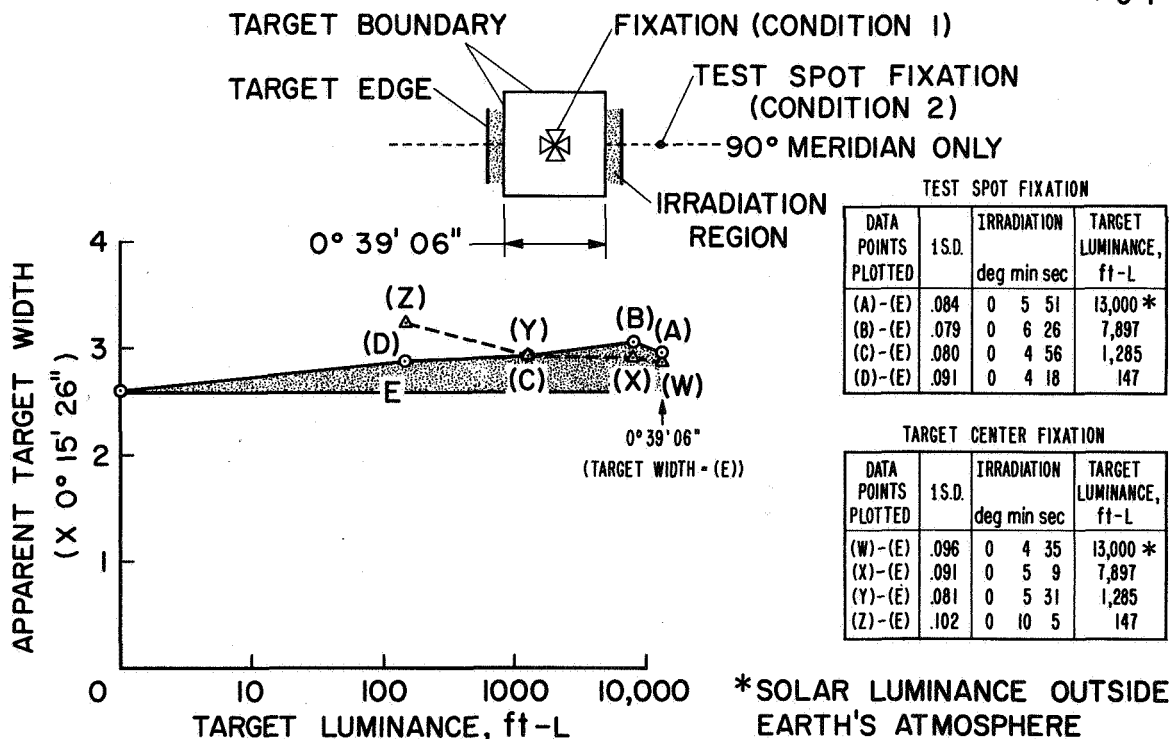

Fig. 5.- The effect of target luminance and two fixation positions upon center of target, upon test spot, and upon apparent target width (irradiation).

JP

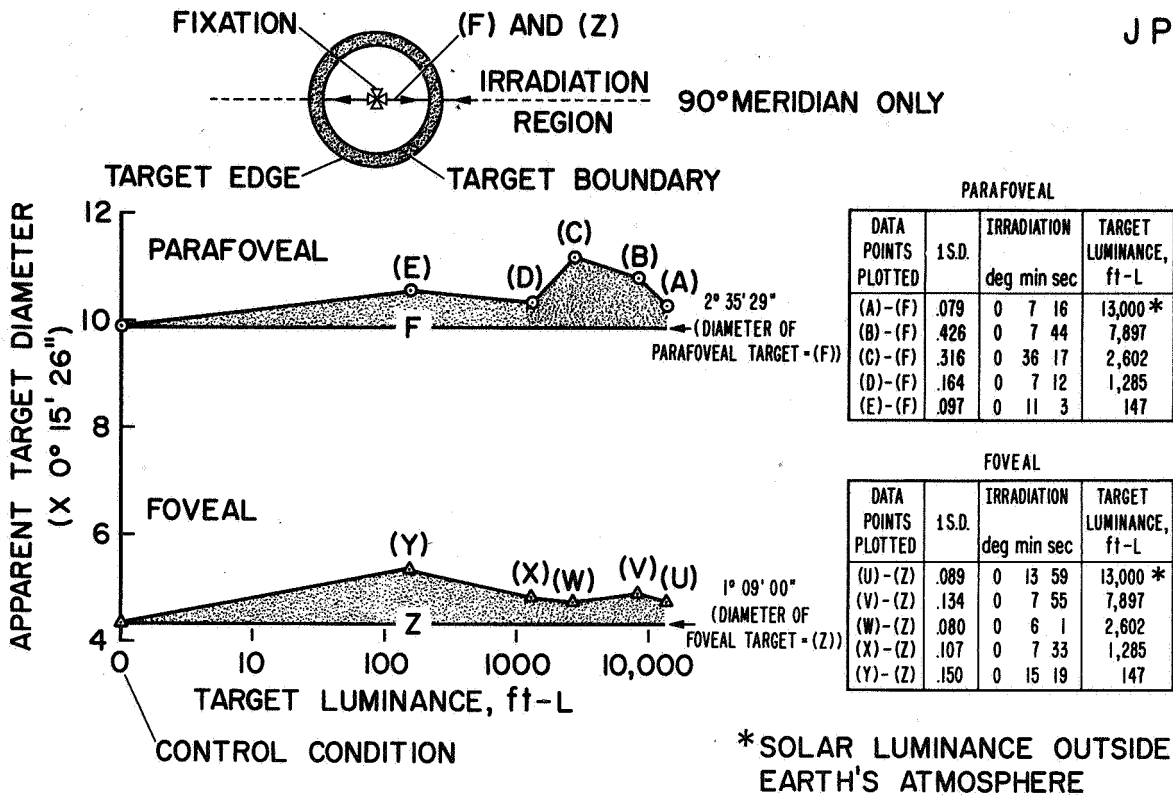

Fig. 6.- The effect of target luminance and size upon apparent target diameter for observer JP.

EC

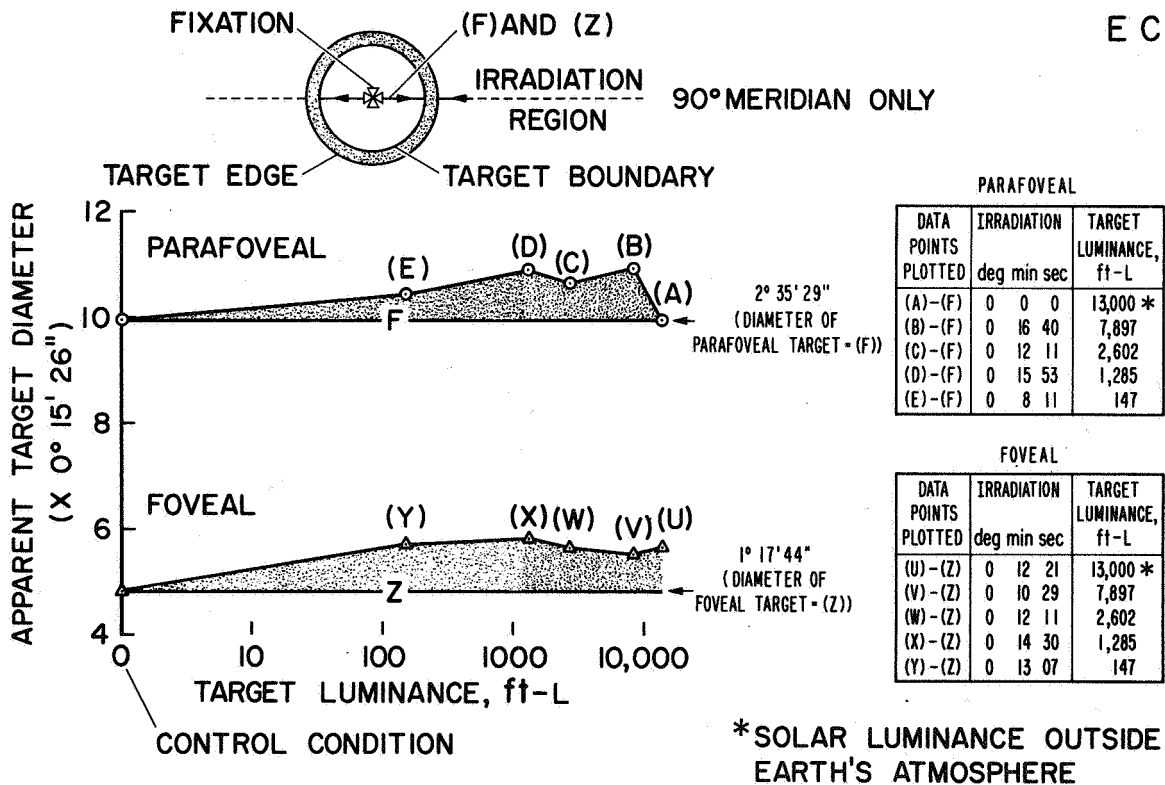

Fig. 7.- The effect of target luminance and size upon apparent target diameter for observer EC.

EXPOSURE, milliseconds

100

100

90

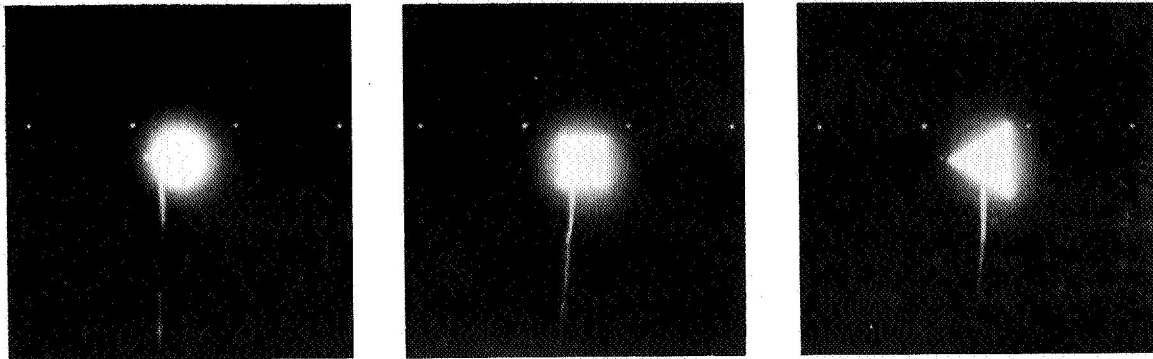

AAA218-8

Fig. 8.- Irradiation effect.

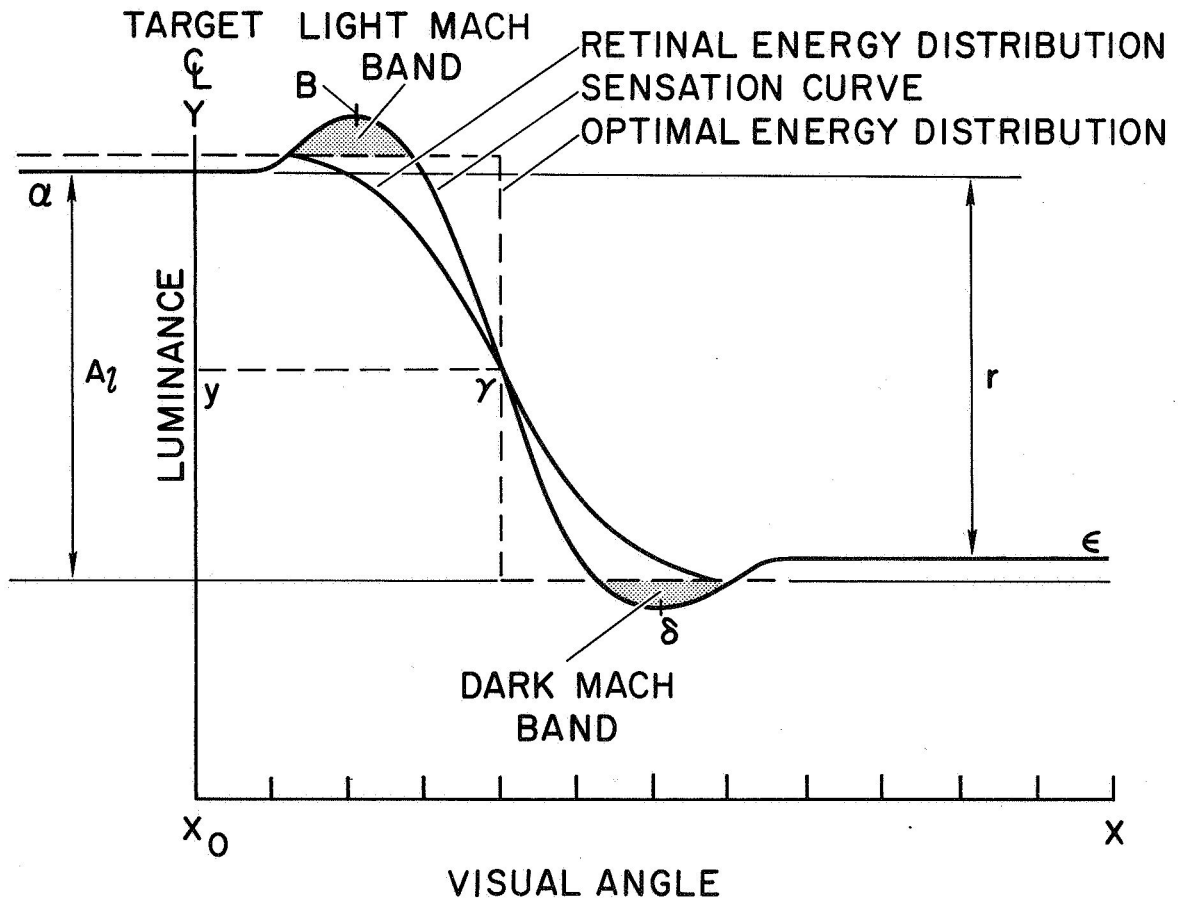

Fig. 9.- Retinal energy distribution.

attainable. Assuming ocular motion about a theoretically "perfect" point of half this amount, one could account for the present irradiation results. The following discussion will attempt to show that the present psychophysically determined data on magnitude of irradiation can be explained on the basis of retinal image instability.^{33,34} The question of change in target shape is treated later.

Figure 10 illustrates, schematically, the supposed effect upon T.S. visibility of one dimensional target image motion due to various eyeglobe

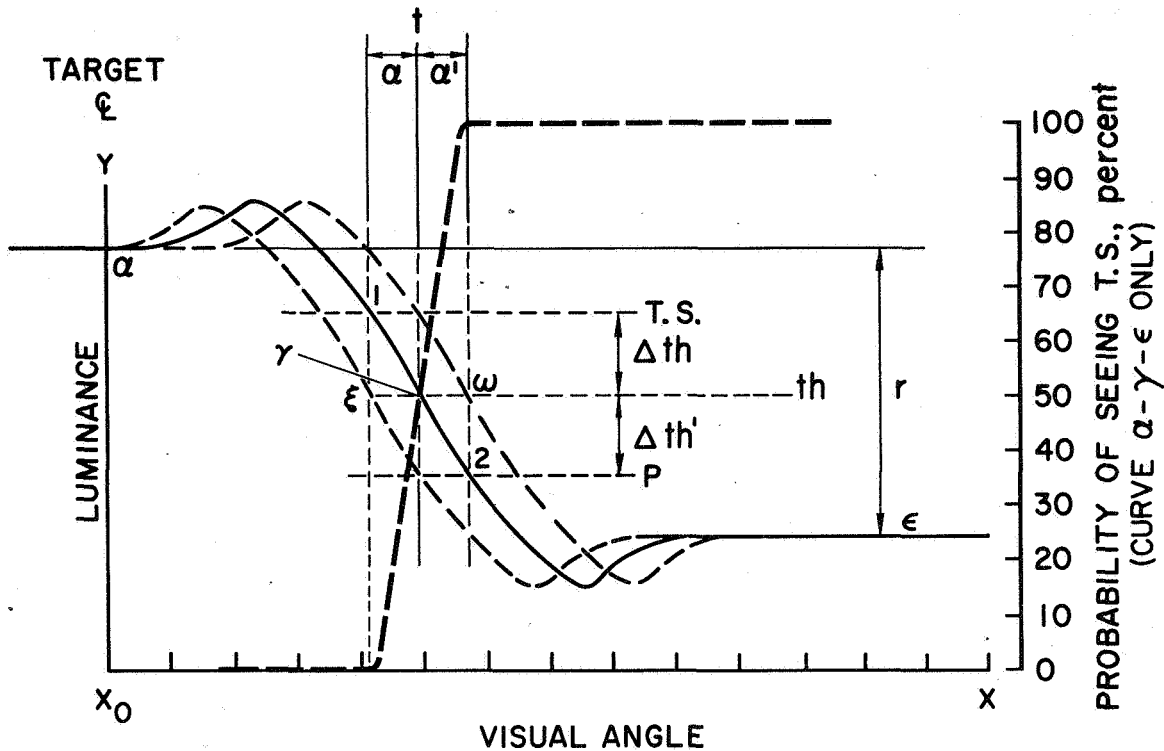

Fig. 10.- Effects of a linear translation of the sensation curve.

motions. The y axis (left side) represents the amount of photic flux falling upon the retina. Range r represents the perceived target-to-background luminance range.

Three sensation curves are shown. The solid curve is the mean and the two dashed curves are the translation limits for a target image motion of magnitude $\pm\alpha$.

The three horizontal dashed lines represent the three visual thresholds for T.S. produced by the three "sensation curves." When the T image moves to the right of the mean position t , it produces the momentary sensation curve $(\alpha, \omega, \epsilon)$, and the threshold (Th) at γ rises by an amount Δth . Likewise, when the T image moves to the left of t , the threshold drops by an amount $\Delta th'$. These threshold fluctuations should produce a retinal area within which the T.S. can be seen accurately with a theoretical probability indicated by the heavy dashed

line.* The 50% point should lie at γ .** It is apparent that the greater the magnitude of T image motion (α and α') the less will be the slope of this probability curve.

On the basis of E.O.G. records obtained during this series of studies, it is presumed that T image motion is the primary cause of the effective expansion (irradiation) of T. Saccadic motion up to $10'$ arc for periods of 3 to 4 sec is not uncommon^{30,35} and could definitely lead to receptor thresholds high enough to keep the T.S. from being seen until either the threshold drops or until the T.S. retinal image position is farther from the T image. This analysis does not rule out other supposed causes of irradiation, but it does provide a reasonable explanation that is consistent with the data.

Another explanation of irradiation involves supposed neural interaction. It suggests that an integration of receptor output occurs within the retina and/or higher centers. If the fovea does have single synaptic connections with the optic tract,⁷ however, such neural spreading of the T image must occur farther along the visual system. The targets in the first and second studies were below 1° in angular subtense and were foveally fixated; therefore, neural interaction would be expected to be minimal under these conditions. It is likely, however, that scattered photic flux from the high luminance T fell upon parafoveal regions.

Both light and dark Mach bands were observed by all observers. The T.S. usually did not disappear on IN trials until it was well into the dark Mach band region. This raises an important question, viz., whether or not the dark Mach band is an area of greatly raised threshold.

Regarding the change in T shape, it must be noted that the total viewing time of each trial was 18 sec. This duration would be sufficient to stabilize pupillary area, light adapt the retina to some relatively constant amount (see Fig. 10), and allow the observer enough time to locate T.S. and make his setting. The artificial pupil only restricted the field of view and controlled scleral sources of scatter. It did not act as the limiting aperture.

One explanation of the apparent rounding phenomenon involves the following reasoning. In the above discussion (see Fig. 10), only linear image motion was treated. Actually the retinal image of the target moves in two dimensions, and a temporal-spatial analysis must be performed. To illustrate this, Fig. 11 presents a square target (heavy outline), with lines of fixational sweep (light dashed lines) originating from the theoretically "perfect" point of fixation with constant magnitude r' . If one plots the new adaptation contour due to fixations along each dashed line corresponding to eyeglobe motion having an amplitude r' , the result is a slightly rounded target (indicated by the heavy dashed line). This adaptation contour is remarkably similar to the results plotted in Figs. 2 and 3 and obtained in previous work.⁴ When triangular and rectangular forms are analyzed in this way the results are very similar to those obtained in previous research.⁴

*This will occur as long as T.S. luminance is within range r .

**This definition of threshold is commonly used for a two-choice task.

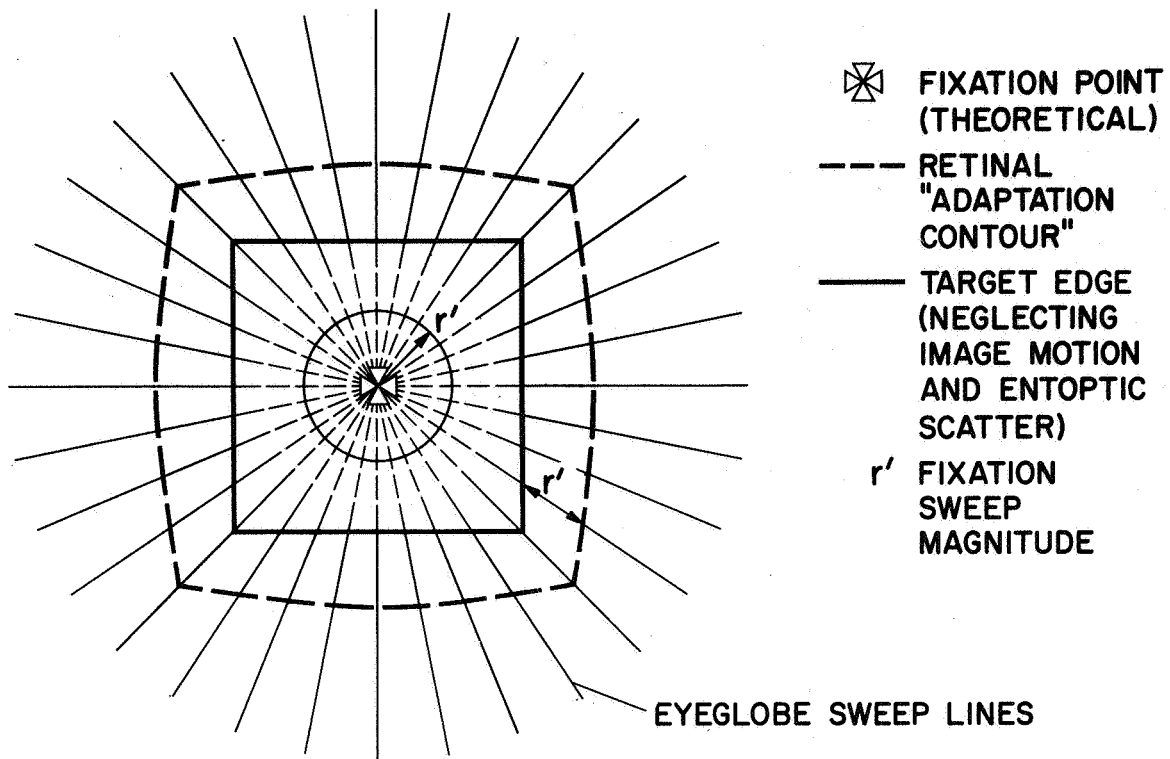

Fig. 11.- Effect of two-dimensional target image motion (under voluntary fixation).

The validity of this explanation rests upon several assumptions: (1) that visual fixation occurs radially from the center of the target with about the same amplitude on each sweep, and (2) that all fixational sweeps are completed before the adaptation level changes significantly.*

Another explanation exists for the apparent rounding of the target. It is well known in physical optics that the Fraunhofer diffraction pattern maximum produced by a small hexagonal or circular aperture is quite rounded for a point source.²⁰ It is possible that the changes in target shape observed in this investigation are the result of such a diffraction pattern upon the retina produced by the pupil and small square target. Present stimulus conditions could produce such a pattern even with an extended source because of the relatively large viewing distances involved. It is suggested that the resultant area of equal (and highest) retinal adaptation produced by such an aperture and square target would be a "rounded" square with cutoff corners. Further investigations are under way to quantify these effects.

*In this context, significantly refers to the degree to which the adaptation state affects visibility for T.S. at that point in time.

SUMMARY

When very bright small targets are foveally fixated against an unilluminated background, they appear larger and rounder than they actually are. The effective expansion in size is called irradiation and is explained as being at least partially due to involuntary ocular motions (e.g., saccades, flicks, etc.) which cause the target's retinal image to light adapt a larger number of retinal receptors than otherwise. It is suggested that the magnitude of irradiation is not related to target luminance as much as to the magnitude of the target's retinal image motion. It is possible that the two interact, however.

If it can be assumed that one's fixation occurs along a radial pattern originating at the center of the target, with relatively constant sweep magnitude, then the present results can be explained. A second hypothesis, however, suggests that the rounded target appearance is the result of a diffraction effect at the pupil. The determination of the exact cause of this change in target appearance must await further investigation.

FOOTNOTES

- ¹T. N. Cornsweet, H. Fowler, R. G. Rabedeau, R. E. Whalen, and D. R. Williams, *Science* 128, 898 (1958).
- ²T. N. Cornsweet, *Psychol. Rev.* 69(4), 257 (1962).
- ³D. McL. Purdy, *Am. J. Psychol.* 43, 541 (1931).
- ⁴R. F. Haines, A Study of Retinal Intensity Gradients (Ph. D. dissertation, Dept. Psychol., Michigan State Univ., East Lansing, Michigan, 1964).
- ⁵R. F. Haines and S. H. Bartley, *J. Psychol.* 62, 255 (1966).
- ⁶H. L. F. von Helmholtz, Helmholtz's Treatise on Physiological Optics (Dover Publications, Inc., New York, 1962), Vol. II, pp. 186, 203.
- ⁷S. L. Polyak, The Retina (The Univ. of Chicago Press, Chicago, Illinois, 1948), pp. 176, 429.
- ⁸Plateau, Mémoire sur l'irradiation (Nouv. mém. de l'Acad. de Bruxelles), T. XI (1838).
- ⁹R. M. Boynton, W. R. Bush, and J. M. Enoch, *J. Opt. Soc. Am.* 43, 814 (1953).
- ¹⁰G. A. Fry and M. Alpern, *J. Opt. Soc. Am.* 43, 189 (1953).
- ¹¹L. L. Holladay, *J. Opt. Soc. Am.* 14, 1 (1927).
- ¹²Y. Le Grand, *Rev. Opt.* 16, 201 (1937).
- ¹³C. L. Crouch, Review of Visual Research as Related to Illuminating Engineering in the U.S.A. (C.I.E. Proceedings, Session Meeting 1.4.1, 13th Session of International Commission on Illumination, Zurich, Switzerland, June 1955), pp. U-C/5 to U-C/23.
- ¹⁴G. A. Fry, *Trans. Am. Illum. Eng. Soc.* 51, 722 (1956).
- ¹⁵S. K. Guth, *J. Opt. Soc. Am.* 41, 235 (1951).
- ¹⁶S. K. Guth, *Trans. Am. Illum. Eng. Soc.* 47, 184 (1952).
- ¹⁷Illuminating Engineering Society, IES Lighting Handbook; The Standard Lighting Guide (*Trans. Am. Illum. Eng. Soc.*, Publ., 1947), 1st ed., pp. 2-18 to 2-27.
- ¹⁸M. Luckiesh and S. K. Guth, *Trans. Am. Illum. Eng. Soc.* 41, 485 (1946).
- ¹⁹P. G. Nutting, *Trans. Am. Illum. Eng. Soc.* 11(9), 939 (1916).
- ²⁰G. B. Parrent, Jr., and B. J. Thompson, Array Theorem, Article 3 (*Physical Optics Notebook, S.P.I.E. Journal*, 1965), vol. 3, p. 138.

- ²¹G. A. Fry, J. Opt. Soc. Am. 37(3), 166 (1947).
- ²²R. L. Williams, J. Opt. Soc. Am. 52, 11 (1962).
- ²³J. L. Kobrick, Effects of Physical Location of Visual Stimuli on Intentional Response Time (Army Res. Office Tenth Ann. Army Human Factors Res. and Dev. Conf., Oct. 1964), p. 227.
- ²⁴V. P. Pease and T. G. Sticht, Percept. and Motor Skills 20, 549 (1965).
- ²⁵R. S. Woodworth and H. Schlosberg, Experimental Psychology (Henry Holt and Co., New York, 1958), rev. ed., p. 196.
- ²⁶W. D. Wright, Proc. Roy. Soc. (London) 115, ser. B, 49 (1934).
- ²⁷D. W. De Mott and R. M. Boynton, J. Opt. Soc. Am. 48, 13 (1958).
- ²⁸R. M. Boynton, J. M. Enoch, and W. R. Bush, J. Opt. Soc. Am. 44, 879 (1954).
- ²⁹R. M. Boynton and F. J. J. Clark, J. Opt. Soc. Am. 54(1), 110 (1964).
- ³⁰F. Ratliff, Mach Bands: Quantitative Studies on Neural Networks in the Retina (Holden-Day, Inc., San Francisco, Calif., 1965), pp. 41, 65.
- ³¹G. v. Bekesy, J. Opt. Soc. Am. 50(11), 1060 (1960).
- ³²S. H. Bartley, Principles of Perception (Harper and Bros., New York, 1958), p. 127.
- ³³G. M. Byram, J. Opt. Soc. Am. 34, 571 (1944).
- ³⁴G. M. Byram, J. Opt. Soc. Am. 34, 718 (1944).
- ³⁵R. W. Ditchburn and B. L. Ginsborg, J. Physiol. 119, 1 (1953).