

**NASA TECHNICAL NOTE**



**NASA TN D-5070**

*c.1*

LOAN COPY: RETURN  
AFWL (WLIL-2)  
KIRTLAND AFB, N M



NASA TN D-5070

**RATIOS OF STEADY-STATE  
RESPONSES TO VARIOUS TRANSIENT  
RESPONSES, BOTH HAVING EQUAL  
MAXIMUM EXCITATION LEVELS**

*by Richard W. Faison*

*Langley Research Center*

*Langley Station, Hampton, Va.*

TECH LIBRARY KAFB, NM



0131923

RATIOS OF STEADY-STATE RESPONSES TO VARIOUS  
TRANSIENT RESPONSES, BOTH HAVING EQUAL  
MAXIMUM EXCITATION LEVELS

By Richard W. Faison

Langley Research Center  
Langley Station, Hampton, Va.

NATIONAL AERONAUTICS AND SPACE ADMINISTRATION

---

For sale by the Clearinghouse for Federal Scientific and Technical Information  
Springfield, Virginia 22151 - CFSTI price \$3.00

RATIOS OF STEADY-STATE RESPONSES TO VARIOUS  
TRANSIENT RESPONSES, BOTH HAVING EQUAL  
MAXIMUM EXCITATION LEVELS

By Richard W. Faison  
Langley Research Center

SUMMARY

Presented herein are acceleration response ratios as determined by a single-degree-of-freedom system analysis for three types of commonly encountered transient excitations. The transient excitations are (1) a modulated sine wave of half-modulation-period duration, (2) a modulated cosine wave of a quarter-modulation-period duration, and (3) a damped sinusoid.

Closed-form solutions for the acceleration responses are obtained by Laplace transform techniques. The ratio of maximum absolute acceleration response for the transient sinusoid to the maximum absolute acceleration response of a steady-state sinusoid having the same frequency is given. Numerical results are presented as the response ratios for various nondimensional parameters.

INTRODUCTION

The laboratory test procedures for sinusoidal and random excitations are well established. However, test procedures for transient excitations are not so universally accepted. In general, transient waveforms are difficult to reproduce on a shaker. The purpose of this paper is to set forth useful parametric data and procedures to adjust the test level of a particular steady-state sinusoidal excitation to yield maximum response amplitudes equivalent to those resulting from particular types of transient excitations. Specifically, the response ratios are given for three transient sinusoids which are similar to those frequently observed on flight records. The procedure is equally amenable to other types of flight transients.

The data presentation of the responses of a single-degree-of-freedom system to transient inputs is generally given in the form of a response spectrum which exhibits peak responses depending on the intensity and shape of the transient input and on the resonator natural frequency. Response spectrum has been defined (ref. 1) as "a graphical presentation of a selected quantity in the response taken with reference to a quantity in the

excitation" and can be plotted as a function of a dimensionless parameter that includes the natural period of the responding system and a significant period of the excitation.

A useful correlation between responses to transient and responses to steady-state inputs may be obtained by utilizing this definition of response spectrum, writing the response-to-excitation ratio in the form  $(R/E)_t$  for the given transient output, and obtaining the corresponding ratio  $(R/E)_{ss}$  for a steady-state sinusoidal excitation having an amplitude equal to the maximum amplitude of the transient excitation and having the same frequency. It should be noted that this statement requires that  $|E_t|_{\max} = |E_{ss}|_{\max}$ .

Hence, the ratio of interest is  $\frac{(R/R)_{ss}}{(R/E)_t} = \frac{R_{ss}}{R_t}$  where the subscripts  $ss$  and  $t$  denote steady-state and transient values.

Response spectra resulting from various step and pulse functions have been presented in references 1 and 2. A very brief response spectrum resulting from a damped sinusoidal excitation has been presented in reference 3. Response ratios for the three types of transients studied herein have been presented in reference 4 for the resonant case only, that is, for the case where the forcing frequency occurs at a natural frequency of the resonator. Also, the data presented in reference 4 were in the form of the ratio of peak response due to the transient input to the peak response due to steady input.

#### SYMBOLS

A	amplitude constant
a,b,c	constants
I( )	imaginary part of complex number
j	complex number, $\sqrt{-1}$
M,P	phasor amplitudes
p	forcing frequency
R( )	real part of complex number
t	time
u	overall displacement

$x$	relative displacement
$\alpha$	decay ratio of excitation function
$\delta$	base displacement
$\zeta$	damping ratio
$\nu$	modulating frequency of excitation function
$\psi, \phi$	phase angles
$\omega$	undamped natural frequency
$\omega_d$	damped natural frequency, $\omega\sqrt{1 - \zeta^2}$

Subscripts:

$i$	variable 1, 2, 3, . . . 7 (see table I)
max	maximum-maximum value
ss	steady-state value
t	transient value

Dots over a symbol denote differentiation with respect to time.

### ANALYSIS

The analysis contained herein is pertinent to a single-degree-of-freedom system with linear damping. The ratio of the absolute acceleration response of a given transient sinusoidal excitation to the absolute acceleration response of a steady-state sinusoidal excitation having the same frequency  $p$  as the transient sinusoidal excitation is to be determined. In addition, the ratios are developed on the basis of the maximum amplitude of excitation of the steady-state sinusoid being equal to that of the transient sinusoid. The coordinate system is shown in the following sketch:

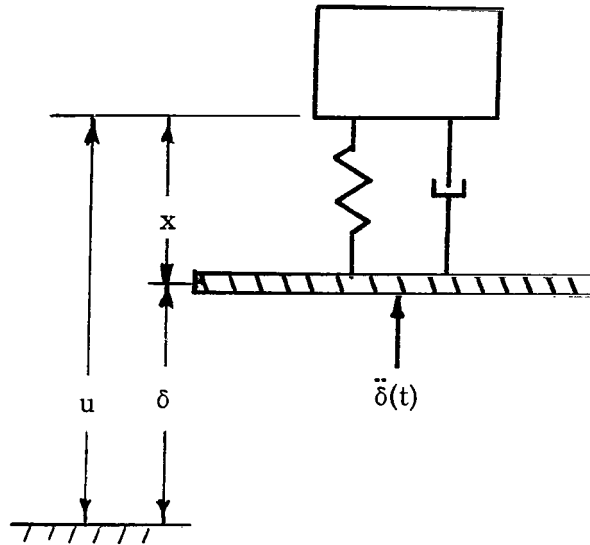

The ratio of the transient to steady-state response  $\frac{\ddot{u}_t/A}{\ddot{u}_{SS}/A} = \frac{\ddot{u}_t}{\ddot{u}_{SS}}$  is given for three types of transient sinusoidal excitations:

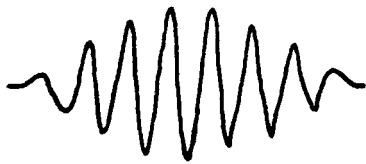

$$\begin{aligned} \ddot{\delta}(t) &= A \sin \nu t \sin pt & (0 \leq t \leq \pi/\nu) \\ &= 0 & (t \geq \pi/\nu) \end{aligned} \quad (1)$$

Modulated sine



$$\begin{aligned} \ddot{\delta}(t) &= A \cos \nu t \cos pt & (0 \leq t \leq \pi/2\nu) \\ &= 0 & (t \geq \pi/2\nu) \end{aligned} \quad (2)$$

Modulated cosine

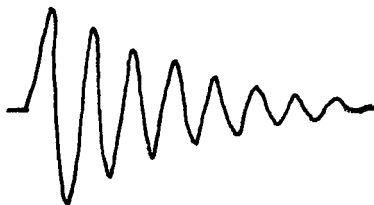

$$\ddot{\delta}(t) = Ae^{-\alpha pt} \sin pt \quad (3)$$

Damped sinusoid

From the system coordinate sketch, the equation of motion is

$$\ddot{x} + 2\zeta\omega\dot{x} + \omega^2x = -\ddot{\delta}(t) \quad (4)$$

The desired absolute response is

$$\ddot{u}(t) = \ddot{\delta}(t) + \ddot{x}(t) \quad (5)$$

The solution of equation (4) for the prescribed excitations may be obtained by analytical procedures such as the method of undetermined coefficients, Laplace transforms, and procedures using an analog computer. The Laplace transform techniques have been selected for use herein to obtain closed-form solutions and are outlined in the appendix.

#### Solution of Steady-State Excitation

The steady-state response expressed as a ratio to the transient response is obtained from equation (4) by letting  $\ddot{\delta}(t) = A \sin pt$ . Equation (4) then becomes

$$\ddot{x} + 2\zeta\omega\dot{x} + \omega^2x = -A \sin pt \quad (6)$$

Assume the initial conditions are  $x(0) = \dot{x}(0) = 0$ ; then

$$\frac{x(pt)_{ss}}{A} = -\frac{1}{P_1\omega^2} \sin(pt - \phi_1) \quad (7)$$

where the values of  $P_1$  and  $\phi_1$  are given in table I, and only the steady-state portion without transients is considered. From equations (5) and (7), the desired absolute response, after simplifying, is written as

$$\frac{\ddot{u}_{ss}}{A} = \sqrt{\frac{1 + \left(2\zeta \frac{p}{\omega}\right)^2}{\left[1 - \left(\frac{p}{\omega}\right)^2\right]^2 + \left(2\zeta \frac{p}{\omega}\right)^2}} \quad (8)$$

This relation is utilized hereafter in establishing the appropriate maximum response ratios.

## Response Ratio for Modulated Sine Excitation

The equation of motion for a single-degree-of-freedom system with linear damping excited by a modulated sine wave of half-modulation duration is

$$\ddot{x} + 2\zeta\omega\dot{x} + \omega^2x = -A \sin \nu t \sin pt \quad (0 \leq t \leq \pi/\nu) \quad (9a)$$

$$\ddot{x} + 2\zeta\omega\dot{x} + \omega^2x = 0 \quad (t > \pi/\nu) \quad (9b)$$

The initial conditions are assumed as  $x(0) = \dot{x}(0) = 0$ . By use of the trigonometric identity

$$\sin \nu t \sin pt = \frac{1}{2} \cos[(p - \nu)t] - \frac{1}{2} \cos[(p + \nu)t] \quad (10)$$

the solution of equation (9a) can be expressed as

$$\begin{aligned} \frac{2x(pt)}{A/\omega^2} = & \frac{e^{-\zeta p/\omega} pt}{\sqrt{1 - \zeta^2}} \left[ \frac{1}{P_4} \sin\left(\frac{\sqrt{1 - \zeta^2}}{p/\omega} pt + \psi_1 - \phi_4\right) - \frac{1}{P_2} \sin\left(\frac{\sqrt{1 - \zeta^2}}{p/\omega} pt + \psi_1 - \phi_2\right) \right] \\ & + \frac{1}{P_5} \cos\left[\left(1 + \frac{\nu}{p}\right)pt - \phi_5\right] - \frac{1}{P_3} \cos\left[\left(1 - \frac{\nu}{p}\right)pt - \phi_3\right] \quad \left(0 \leq pt \leq \frac{\pi}{\nu/p}\right) \quad (11) \end{aligned}$$

and the solution of equation (9b) can be expressed as

$$\begin{aligned} \frac{2x(pt)}{A/\omega^2} = & \frac{e^{-\zeta p/\omega} pt}{\sqrt{1 - \zeta^2}} \left[ \frac{1}{P_4} \sin\left(\frac{\sqrt{1 - \zeta^2}}{p/\omega} pt + \psi_1 - \phi_4\right) - \frac{1}{P_2} \sin\left(\frac{\sqrt{1 - \zeta^2}}{p/\omega} pt + \psi_1 - \phi_2\right) \right] + \frac{e^{-\zeta p/\omega} p(t-t_1)}{P_5\sqrt{1 - \zeta^2}} \left\{ \left[ \zeta \cos(\sigma_1 - \phi_5) \right. \right. \\ & \left. \left. + \frac{p}{\omega} \left(1 + \frac{\nu}{p}\right) \sin(\sigma_1 - \phi_5) \right] \sin\left[\frac{\sqrt{1 - \zeta^2}}{p/\omega} p(t - t_1)\right] + \sqrt{1 - \zeta^2} \cos(\sigma_1 - \phi_5) \cos\left[\frac{\sqrt{1 - \zeta^2}}{p/\omega} p(t - t_1)\right] \right\} \\ & - \frac{e^{-\zeta p/\omega} p(t-t_1)}{P_3\sqrt{1 - \zeta^2}} \left\{ \left[ \zeta \cos(\sigma_2 - \phi_3) + \frac{p}{\omega} \left(1 - \frac{\nu}{p}\right) \sin(\sigma_2 - \phi_3) \right] \sin\left[\frac{\sqrt{1 - \zeta^2}}{p/\omega} p(t - t_1)\right] \right. \\ & \left. + \sqrt{1 - \zeta^2} \cos(\sigma_1 - \phi_3) \cos\left[\frac{\sqrt{1 - \zeta^2}}{p/\omega} p(t - t_1)\right] \right\} \quad (pt > pt_1) \quad (12) \end{aligned}$$



where the values of  $P_i$ ,  $\psi_i$ , and  $\phi_i$  are listed in table I and  $t_1 = \frac{\pi}{\nu}$ ,  $\sigma_1 = \pi\left(\frac{1}{\nu/p} + 1\right)$ , and  $\sigma_2 = \pi\left(\frac{1}{\nu/p} - 1\right)$ . The absolute acceleration as given by equation (5) can be obtained

from the second differential of equations (11) and (12) and from equation (1). The desired absolute acceleration response ratio is then obtained by dividing by equation (8).

$$\frac{\ddot{u}_t(pt)}{\ddot{u}_{ss}} = \sqrt{\frac{\left[1 - \left(\frac{p}{\omega}\right)^2\right]^2 + 2\zeta\left(\frac{p}{\omega}\right)^2}{1 + \left(2\zeta\frac{p}{\omega}\right)^2}} \left\{ \sin\frac{\nu}{p}pt \sin pt - \frac{M_1^3 e^{-\zeta p/\omega} pt}{2\sqrt{1 - \zeta^2 P_2}} \sin\left(\frac{\sqrt{1 - \zeta^2}}{p/\omega} pt + 3\psi_1 - \phi_2\right) + \frac{\left(\frac{p}{\omega}\right)^2 \left(1 - \frac{\nu}{p}\right)}{2P_3} \cos\left[\left(1 - \frac{\nu}{p}\right)pt - \phi_3\right] \right. \\ \left. + \frac{M_1^3 e^{-\zeta p/\omega} pt}{2\sqrt{1 - \zeta^2 P_4}} \sin\left(\frac{\sqrt{1 - \zeta^2}}{p/\omega} pt + 3\psi_1 - \phi_4\right) - \frac{\left(\frac{p}{\omega}\right)^2 \left(1 + \frac{\nu}{p}\right)}{2P_5} \cos\left[\left(1 + \frac{\nu}{p}\right)pt - \phi_5\right] \right\} \quad \left(0 \leq pt \leq \frac{\pi}{\nu/p}\right) \quad (13)$$

For time greater than  $\pi/\nu$ , the solution can be obtained by use of the Laplace shifting theorem

$$\frac{\ddot{u}_t(pt)}{\ddot{u}_{ss}} = \frac{e^{-\zeta p/\omega} pt}{2\sqrt{1 - \zeta^2}} \sqrt{\frac{\left[1 - \left(\frac{p}{\omega}\right)^2\right]^2 + \left(2\zeta\frac{p}{\omega}\right)^2}{1 + \left(2\zeta\frac{p}{\omega}\right)^2}} \left\{ \left[ \frac{-1}{P_4} \sin\left(\frac{\sqrt{1 - \zeta^2}}{p/\omega} pt_1 + \psi_1 - \phi_4\right) + \frac{1}{P_2} \sin\left(\frac{\sqrt{1 - \zeta^2}}{p/\omega} pt_1 \right. \right. \right. \\ \left. \left. \left. + \psi_1 - \phi_2\right) \right] \frac{1}{\sqrt{1 - \zeta^2}} \sin\left[\frac{\sqrt{1 - \zeta^2}}{p/\omega} p(t - t_1) + \psi_1\right] + \left[ \frac{1}{P_4} \sin\left(\frac{\sqrt{1 - \zeta^2}}{p/\omega} pt_1 + 2\psi_1 - \phi_4\right) - \frac{1}{P_2} \sin\left(\frac{\sqrt{1 - \zeta^2}}{p/\omega} pt_1 \right. \right. \right. \\ \left. \left. \left. + 2\psi_1 - \phi_2\right) \right] \frac{1}{\sqrt{1 - \zeta^2}} \sin\left[\frac{\sqrt{1 - \zeta^2}}{p/\omega} p(t - t_1) + 2\psi_1\right] + e^{\zeta p/\omega} pt_1 \sin\left[\frac{\sqrt{1 - \zeta^2}}{p/\omega} p(t - t_1) + \psi_1\right] \left[ \frac{-1}{P_5} \cos(\sigma_1 - \phi_5) \right. \right. \\ \left. \left. + \frac{1}{P_3} \cos(\sigma_2 - \phi_3) \right] + e^{\zeta p/\omega} pt_1 \sin\left[\frac{\sqrt{1 - \zeta^2}}{p/\omega} p(t - t_1) + 2\psi_1\right] \left[ \frac{p}{\omega} \left(1 + \frac{\nu}{p}\right) \frac{\sin(\sigma_1 - \phi_5)}{P_5} - \frac{p}{\omega} \left(1 - \frac{\nu}{p}\right) \frac{\sin(\sigma_2 - \phi_3)}{P_3} \right] \right\} \quad \left(pt > \frac{\pi}{\nu/p}\right) \quad (14)$$

where the values of  $P_i$ ,  $M_i$ ,  $\phi_i$ , and  $\psi_i$  are listed in table I, and  $t_1 = \frac{\pi}{\nu}$ ,  $\sigma_1 = \pi\left(\frac{1}{\nu/p} + 1\right)$ , and  $\sigma_2 = \pi\left(\frac{1}{\nu/p} - 1\right)$ .

### Response Ratio for Modulated Cosine Excitation

The equation of motion for a single-degree-of-freedom system with linear damping excited by a modulated cosine wave with duration of one-quarter modulation period is

$$\ddot{x} + 2\zeta\omega\dot{x} + \omega^2x = -A \cos \nu t \cos pt \quad \left(0 \leq t \leq \frac{\pi}{2\nu}\right) \quad (15a)$$

$$\ddot{x} + 2\zeta\omega\dot{x} + \omega^2x = 0 \quad \left(t > \frac{\pi}{2\nu}\right) \quad (15b)$$

The initial conditions are assumed as  $x(0) = \dot{x}(0) = 0$ . By using the trigonometric identity

$$\cos \nu t \cos pt = \frac{1}{2} \cos[(p - \nu)t] + \frac{1}{2} \cos[(p + \nu)t] \quad (16)$$

and noting the similarity to equation (10), the acceleration response ratio for the modulated cosine excitation can be written immediately as

$$\begin{aligned} \frac{\ddot{u}_t(pt)}{\ddot{u}_{ss}} = & \sqrt{\frac{\left[1 - \left(\frac{p}{\omega}\right)^2\right]^2 + \left(2\zeta \frac{p}{\omega}\right)^2}{1 + \left(2\zeta \frac{p}{\omega}\right)^2}} \left\{ \cos \frac{\nu}{p} pt \cos pt - \frac{M_1^3 e^{\frac{-\zeta}{p/\omega} pt}}{2\sqrt{1 - \zeta^2} P_2} \sin\left(\frac{\sqrt{1 - \zeta^2}}{p/\omega} pt + 3\psi_1 - \phi_2\right) \right. \\ & + \frac{\left(\frac{p}{\omega}\right)^2 \left(1 - \frac{\nu}{p}\right)}{2P_3} \cos\left[\left(1 - \frac{\nu}{p}\right)pt - \phi_3\right] - \frac{e^{\frac{-\zeta}{p/\omega} pt}}{2\sqrt{1 - \zeta^2} P_4} \sin\left(\frac{\sqrt{1 - \zeta^2}}{p/\omega} pt + 3\psi_1 - \phi_4\right) \\ & \left. + \frac{\left(\frac{p}{\omega}\right)^2 \left(1 + \frac{\nu}{p}\right)}{2P_5} \cos\left[\left(1 + \frac{\nu}{p}\right)pt - \phi_5\right] \right\} \quad \left(0 \leq pt \leq \frac{\pi}{2\nu/p}\right) \quad (17) \end{aligned}$$

and

$$\begin{aligned}
\frac{\ddot{u}_t(pt)}{\ddot{u}_{ss}} = & \frac{-\zeta}{2\sqrt{1-\zeta^2}} \left[ \frac{1 - \left(\frac{p}{\omega}\right)^2 + \left(2\zeta\frac{p}{\omega}\right)^2}{1 + \left(2\zeta\frac{p}{\omega}\right)^2} \left[ \frac{-1}{P_4} \sin\left(\frac{\sqrt{1-\zeta^2}}{p/\omega} pt_1 + \psi_1 - \phi_4\right) - \frac{1}{P_2} \sin\left(\frac{\sqrt{1-\zeta^2}}{p/\omega} pt_1 + \psi_1 - \phi_2\right) \right] \frac{1}{\sqrt{1-\zeta^2}} \sin\left[\frac{\sqrt{1-\zeta^2}}{p/\omega} p(t-t_1) + \psi_1\right] \right. \\
& + \left[ \frac{1}{P_4} \sin\left(\frac{\sqrt{1-\zeta^2}}{p/\omega} pt_1 + 2\psi_1 - \phi_4\right) + \frac{1}{P_2} \sin\left(\frac{\sqrt{1-\zeta^2}}{p/\omega} pt_1 + 2\psi_1 - \phi_2\right) \right] \frac{1}{1-\zeta^2} \sin\left[\frac{\sqrt{1-\zeta^2}}{p/\omega} p(t-t_1) + 2\psi_1\right] \\
& + e^{\frac{\zeta}{p/\omega} pt_1} \sin\left[\frac{\sqrt{1-\zeta^2}}{p/\omega} p(t-t_1) + \psi_1\right] \left[ -\frac{1}{P_5} \cos(\sigma_1 - \phi_5) - \frac{1}{P_3} \cos(\sigma_2 - \phi_3) \right] + e^{\frac{\zeta}{p/\omega} pt_1} \sin\left[\frac{\sqrt{1-\zeta^2}}{p/\omega} p(t-t_1) \right. \\
& \left. + 2\psi_1 \right] \left[ \frac{p}{\omega} \frac{(1 + \nu/p)}{P_5} \sin(\sigma_1 - \phi_5) + \frac{p}{\omega} \frac{(1 - \nu/p)}{P_3} \sin(\sigma_2 - \phi_3) \right] \left. \right\} \quad \left( pt > \frac{\pi}{2\nu/p} \right) \quad (18)
\end{aligned}$$

where the values of  $P_i$ ,  $M_i$ ,  $\phi_i$ , and  $\psi_i$  are listed in table I and  $t_1 = \frac{\pi}{2\nu/p}$ ,  
 $\sigma_3 = \frac{\pi}{2} \left( \frac{1}{\nu/p} + 1 \right)$ , and  $\sigma_4 = \frac{\pi}{2} \left( \frac{1}{\nu/p} - 1 \right)$ .

### Response Ratio for Damped Sinusoidal Excitation

For a single-degree-of-freedom system excited by a damped sinusoidal acceleration, the equation of motion is

$$\ddot{x} + 2\zeta\omega\dot{x} + \omega^2x = -Ae^{-\alpha pt} \sin pt \quad (19)$$

For the initial conditions  $x(0) = \dot{x}(0) = 0$ , the following solution is valid except when  $\alpha p = \zeta\omega$  and  $p = \omega_d$

$$\frac{x(pt)}{A/\omega^2} = -\frac{p}{\sqrt{1-\zeta^2}P_6} \frac{e^{-\frac{\zeta}{p/\omega} pt}}{e^{p/\omega} pt} \cos\left(\frac{\sqrt{1-\zeta^2}}{p/\omega} pt - \phi_6\right) - \frac{e^{-\alpha pt} \cos(pt - \phi_7)}{(p/\omega)^2 P_7} \quad (20)$$

where the values of  $P_i$  and  $\phi_i$  are listed in table I. The absolute acceleration as given by equation (5) can be obtained by the second differential of equation (20) and

equation (3). The desired absolute acceleration response ratio is then obtained by dividing by equation (8).

$$\frac{\ddot{u}_t(pt)}{\ddot{u}_{SS}} = \sqrt{\frac{1 - \left(\frac{p}{\omega}\right)^2 + \left(2\zeta \frac{p}{\omega}\right)^2}{1 + \left(2\zeta \frac{p}{\omega}\right)^2}} \left[ e^{-\alpha pt} \sin pt - \frac{p}{\omega} \frac{M_1^2 e^{-\zeta p/\omega} pt}{\sqrt{1 - \zeta^2 P_6}} \sin\left(\frac{\sqrt{1 - \zeta^2}}{p/\omega} pt + 2\psi_1 - \phi_6\right) - \frac{M_2^2 e^{-\alpha pt}}{P_7} \sin(pt + 2\psi_2 - \phi_7) \right] \quad (21)$$

### Digital Computation

The closed-form solutions of the absolute response ratio  $\ddot{u}_t/\ddot{u}_{SS}$  as given by equations (13) and (14) for the modulated sine excitation, by equations (17) and (18) for the modulated cosine excitation, and by equation (21) for the damped sinusoidal excitation have been programed for digital computation. The maximum-maximum values of these equations given in terms of the dimensionless time parameter  $pt$  were determined. The dimensionless time increment chosen was based on one-sixteenth the time period of  $\omega$  or  $p$ , whichever was the higher in frequency. Also, note that the reciprocals of maximum-maximum values as determined by equations (13), (14), (17), (18), and (21) are the values plotted in the figures.

### RESULTS AND DISCUSSION

Because of the number of parameters involved in the response ratio, the results are difficult to depict concisely. For example, the response ratio resulting from a modulated sine excitation as given by equations (13) and (14) is a function of four independent parameters  $\zeta$ ,  $\nu/p$ ,  $p/\omega$ , and  $pt$  as shown in the following sketch where  $\zeta$  and  $\nu/p$  can assume any assigned value

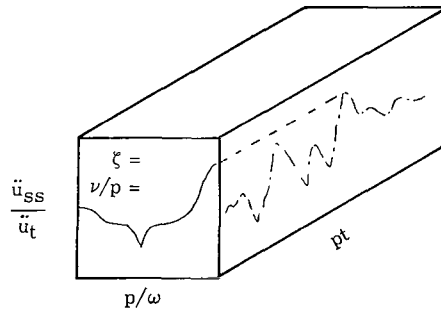

Because the maximum of the response ratio  $\ddot{u}_{SS}/\ddot{u}_t$  is desired, and not the time histories, the parameter  $pt$  has been eliminated in depicting the results.

The modulated sinusoids involve a variety of transient waveforms as the parameter  $\nu/p$  varies from 0 to 1.0. When  $\nu/p = 0$ , that is, the modulation period is infinite, the modulated sinusoid becomes a steady-state excitation. For  $\nu/p = 1.0$ , the modulated sinusoid takes the form of  $\sin^2 pt = 1 - \cos^2 pt$ , and resembles the shape of a bell pulse. These waveforms, as well as many intermediate ones, are depicted in figure 1. The damped sinusoid includes another parameter in terms of the damping rate of the forcing function which is independent of the resonator damping.

### Presentation of Numerical Results

The time histories of a modulated sine excitation and corresponding responses of a single-degree-of-freedom system as determined by analog computer are presented as figure 1. The analog procedure, although not used as the primary means of solution, is convenient for examining graphically the time histories of the transient responses. Figure 1 shows that (1) the steady-state response as used herein does not include transient contributions, (2) the maximum amplitude of the steady-state excitation is the same amplitude as that of the transient excitation, and (3) the steady-state excitation and the transient excitation are of the same frequency  $p$ .

The response ratio  $\ddot{u}_{SS}/\ddot{u}_t$  for the modulated sine excitation is shown as figure 2 for an extended range of modulation parameters. Note that for the resonant case  $p/\omega = 1.0$ , the ratio is significantly greater than that for the off-resonance case.

From figure 1 it can be seen that although all the depicted excitations are modulated sines for values of  $\nu/p$  between 0.1 and 1.0, it becomes difficult to visualize these excitations as modulated sinusoids. The application of the modulated sine excitations generally would be limited to values of  $\nu/p$  less than 0.1 because of the loss of identity of the modulated sine excitations for values of  $\nu/p$  greater than 0.1. For the modulated sine excitation, the response ratios are given in figures 3(a), 3(b), and 3(c) for the cases of modulation to forcing frequency  $\nu/p$  of 0.02, 0.06, and 0.1, respectively. In figure 3 the variation of the response ratio is given for system damping values of  $\zeta = 0.001$ ,  $\zeta = 0.01$ , and  $\zeta = 0.1$ . Figure 4 shows the effects of the parameter  $\nu/p$  on the response ratio for a damping of  $\zeta = 0.01$ .

The variation of the modulated cosine response ratio  $\ddot{u}_{SS}/\ddot{u}_t$  as the modulation to forcing frequency  $\nu/p$  is varied between the extremes 0 to 1.0 is given as figure 5. Figure 5 is analogous to figure 2, where the excitation is a modulated sine. For the resonance case  $p/\omega = 1.0$  the response ratio is significantly greater than the off-resonance case.

The response ratio resulting from a modulated cosine excitation is shown in figures 6(a), 6(b), and 6(c) for a given modulation to forcing frequency  $\nu/p$  of 0.02, 0.06, and 0.1, respectively. In figure 6, the variation of the response ratio is given for system damping values of  $\zeta = 0.001$ ,  $\zeta = 0.01$ , and  $\zeta = 0.1$ . Figure 7 shows the effect of the variation of the parameter  $\nu/p$  on the response ratio for a damping of  $\zeta = 0.01$ .

Figures 8 and 9 show the values of the response ratio  $\ddot{u}_{SS}/\ddot{u}_t$  for a damped sinusoid excitation. The effect of system damping is shown as figure 8 for the excitation decay parameter  $\alpha = 0.03$  and values of system damping  $\zeta$  of 0.001 and 0.1. The curve for  $\zeta = 0.01$  is hardly discernible from the curve for  $\zeta = 0.001$  except at the resonant point  $p/\omega = 1.0$ ; consequently, only the maximum value at the resonant point is noted for  $\zeta = 0.01$ . The effect of excitation decay parameter  $\alpha$  on the response ratio is shown in figure 9 for a system damping of  $\zeta = 0.01$ . The response ratios shown in figure 9 are given for  $\alpha = 0.01$  and  $\alpha = 0.05$ , and only the response ratio at resonance is shown for  $\alpha = 0.03$ .

#### Assumptions and Limitations

The derivations and the procedure considered herein are based on the idealized conditions of a single-degree-of-freedom system subjected to explicit excitations. Discussions of the interpretation of flight transient data, philosophies of testing, and rationales involved in determining whether a complex structural assembly can be represented adequately by a single-degree-of-freedom system are beyond the scope of this paper. It is left to the reader to determine whether the explicit transients considered herein could serve as an appropriate approximation for his particular situation. It is also assumed that the structural assembly exhibits structural resonances sufficiently separated to allow the modal contribution to be considered to be composed of entirely one mode; thus the behavior of a single-degree-of-freedom system is exemplified.

The following application section utilizes a method of determining the steady-state amplitude input to obtain magnitudes of acceleration equal to those which could be experienced by the resonator due to the transient input when both the transient and steady-state inputs have the same frequency  $p$ . Obviously, in practical application the time duration of such a test would subject the resonator to many more cycles of oscillation than the short-duration transient would. From a stress-cycle standpoint, such steady-state testing for transient simulation is certainly more severe than transient testing and hence is inherently a conservative procedure. The large number of oscillations inherent in a steady-state excitation test should be considered for systems in which fatigue failures are likely.

## Application

The application of the results given herein are explained and presented as example problems.

Example 1.- What amplitude of steady-state sinusoidal excitation would be necessary to obtain a response equal to the maximum response amplitude due to a given transient sinusoidal excitation, both excitations having the same frequency  $p$ ?

**Solution:** The maximum steady-state acceleration output is to be equal to the maximum transient acceleration response. By definition

$$\frac{\ddot{u}_{SS}}{\ddot{\delta}_{SS}}(\ddot{\delta}_{SS}) = \text{Output steady state}$$

$$\frac{\ddot{u}_t}{\ddot{\delta}_t}(\ddot{\delta}_t) = \text{Output transient}$$

Equating these terms yields

$$\frac{\ddot{u}_{SS}}{\ddot{\delta}_{SS}}(\ddot{\delta}_{SS}) = \frac{\ddot{u}_t}{\ddot{\delta}_t}(\ddot{\delta}_t)$$

Dividing by the right-hand side yields

$$\left( \frac{\ddot{u}_{SS}/\ddot{\delta}_{SS}}{\ddot{u}_t/\ddot{\delta}_t} \right) \frac{\ddot{\delta}_{SS}}{\ddot{\delta}_t} = 1$$

The term  $\frac{\ddot{u}_{SS}/\ddot{\delta}_{SS}}{\ddot{u}_t/\ddot{\delta}_t}$  is precisely the response ratio as determined by the analysis presented herein, the steady-state and transient input level being equal, and has been denoted as  $\ddot{u}_{SS}/\ddot{u}_t$ . Then

$$\delta_{SS} = \frac{\ddot{\delta}_t}{\ddot{u}_{SS}/\ddot{u}_t}$$

where the transient and steady-state frequencies  $p$  are equal and the amplitudes are maximum-maximum values.

Example 2.- The observed torsional acceleration response at the base of a payload section was a transient consisting of a modulated sine of half-modulation-period duration

with a maximum magnitude of  $32.5 \text{ rad/sec}^2$ . The modulation and forcing frequencies were  $8\pi \text{ rad/sec}$  and  $134\pi \text{ rad/sec}$ , respectively. The structural payload frequencies were  $118\pi \text{ rad/sec}$  and  $222\pi \text{ rad/sec}$  for the first and second torsional modes, respectively. What level of steady-state excitation would yield equivalent maximum acceleration amplitudes in the payload?

Solution: It is assumed that the  $222\pi \text{ rad/sec}$  excitation is sufficiently removed from the  $134\pi \text{ rad/sec}$  excitation (that is, in comparison with  $118\pi \text{ rad/sec}$ ) to be unaffected. The pertinent information is then

$$\frac{p}{\omega} = \frac{134\pi}{118\pi} = 1.14$$

$$\frac{\nu}{p} = \frac{8\pi}{134\pi} = 0.06$$

$$\zeta = 0.01 \text{ (payload damping estimated)}$$

$$\ddot{\delta}_t = 32.5 \text{ rad/sec}^2$$

From figure 3(b)

$$\frac{\ddot{u}_{SS}}{\ddot{u}_t} = 0.497$$

then

$$\ddot{\delta}_{SS} = \frac{32.5 \text{ rad/sec}^2}{0.497} = 65.39 \text{ rad/sec}^2$$

Thus, a steady-state excitation at a level of  $65.39 \text{ rad/sec}^2$  and a frequency of  $134\pi \text{ rad/sec}$  would produce a response equivalent to the maximum level produced by the transient excitation.

## CONCLUSIONS

In applying a steady-state sinusoidal excitation to obtain an equivalent maximum response such as that which would result from a given transient sinusoid, the following observations have been made



(1) The steady-state input amplitudes are highly dependent upon the ratio of transient frequency to system natural frequency. The required steady-state excitation is generally higher than the maximum transient input excitation for the off-resonant case.

(2) For the off-resonant case, system damping is less critical than that for the resonant and near-resonant cases in determining the steady-state excitation amplitude.

(3) The steady-state excitation as proposed herein, although it yields responses equivalent to the transient excitation, subjects the resonator to many more cycles of oscillation than the short-duration transient would and is therefore a conservative procedure.

Langley Research Center,

National Aeronautics and Space Administration,

Langley Station, Hampton, Va., October 9, 1968,

124-08-05-25-23.

## APPENDIX

### LAPLACE TRANSFORM TECHNIQUES FOR FACTORS HAVING COMPLEX CONJUGATE ROOTS

Although Laplace transform techniques are widely used, some of the features used to facilitate the solutions in this report are summarized in this appendix.

A general form of a transform  $\mathcal{L}(\ )$  is given as

$$\begin{aligned}\mathcal{L}(x) &= \frac{s}{(s^2 + p^2) \left[ (s + \zeta\omega)^2 + \omega_d^2 \right]} \\ &= \frac{s}{(s + jp)(s - jp) \left[ (s + \zeta\omega) + j\omega_d \right] \left[ (s + \zeta\omega) - j\omega_d \right]}\end{aligned}\tag{A1}$$

where  $s$  is a Laplace transform operator.

The four poles of relation (A1) consist of two roots of complex conjugate pairs, for each of which exists a complex conjugate solution, the sum of their imaginary parts equaling zero. Each conjugate pair thus yields a solution which is equal to twice the real part of either one of the pairs. However, an expedient solution is obtained by the use of the following identity, where  $Ne^{j\gamma}$  is any complex number

$$\mathbf{R}\left(\frac{Ne^{j\gamma}}{j} e^{j\omega t}\right) = \mathbf{I}\left(Ne^{j\gamma} e^{j\omega t}\right)\tag{A2}$$

Expanding equation (A1) into partial fractions utilizing the method of Heaviside and also considering only the real parts yields

$$\begin{aligned}x(t) &= 2\mathbf{R} \frac{jp e^{jpt}}{2jp \left[ (\zeta\omega + jp)^2 + \omega_d^2 \right]} + 2\mathbf{R} \frac{(-\zeta\omega + j\omega_d) e^{(-\zeta\omega + j\omega_d)t}}{2j\omega_d \left[ (-\zeta\omega + j\omega_d)^2 + p^2 \right]} \\ &= \mathbf{R} \frac{e^{jpt}}{(\zeta\omega + jp)^2 + \omega_d^2} + \mathbf{R} \frac{(-\zeta\omega + j\omega_d) e^{(-\zeta\omega + j\omega_d)t}}{j\omega_d \left[ (-\zeta\omega + j\omega_d)^2 + p^2 \right]}\end{aligned}\tag{A3}$$

## APPENDIX

Equation (A3) can be differentiated twice with respect to time to yield

$$\ddot{x}(t) = \text{R} \frac{-p^2 e^{jpt}}{(\xi\omega + jp)^2 + \omega_d^2} + \text{I} \frac{(-\xi\omega + j\omega_d)^3 e^{(-\xi\omega + j\omega_d)t}}{\omega_d [(-\xi\omega + j\omega_d)^2 + p^2]} \quad (\text{A4})$$

where identity (A2) has been used on the last term. The phasors given in equations (A3) and (A4) can be written in terms of an amplitude and a phase relation as

$$(a + jb)^2 + c^2 = \sqrt{(a^2 - b^2 + c^2)^2 + (2ab)^2} e^{j\phi} \quad (\text{A5})$$

where

$$\phi = \tan^{-1} \frac{2ab}{a^2 - b^2 + c^2} \quad (\text{A6})$$

Let

$$P = \sqrt{(a^2 - b^2 + c^2)^2 + (2ab)^2} \quad (\text{A7})$$

then

$$(a + jb)^2 + c^2 = P e^{j\phi} \quad (\text{A8})$$

Similarly,

$$a + jb = M e^{j\psi} \quad (\text{A9})$$

where

$$\psi = \tan^{-1} \frac{b}{a} \quad (\text{A10})$$

and

$$M = \sqrt{a^2 + b^2} \quad (\text{A11})$$

## APPENDIX

Let the constants  $a$ ,  $b$ , and  $c$  of equations (A5) to (A8) assume the values:

$$\begin{array}{lll}
 a_1 = \zeta\omega & a_2 = -\zeta\omega & a_3 = 0 \\
 b_1 = p & b_2 = \omega_d & b_3 = \omega_d \\
 c_1 = \omega_d & c_2 = p & c_3 = -\zeta\omega
 \end{array}$$

let the constants  $a$  and  $b$  of equations (A9) to (A11) assume the values  $a_1 = -\zeta\omega$  and  $b_1 = \omega_d$ ; then, equations (A3) and (A4) can be written in terms of subscript phasor amplitudes and phases as

$$x(t) = \frac{1}{P_1} \cos(pt - \phi_1) + \frac{M_1}{\omega_d P_2} e^{-\zeta\omega t} \sin(\omega_d t + \psi_1 - \phi_2) \quad (\text{A12})$$

$$\ddot{x}(t) = \frac{-a^2}{P_1} \cos(pt - \phi_1) + \frac{M_1^3 e^{-\zeta\omega t}}{\omega_d P_2} \sin(\omega_d t + 3\psi_1 - \phi_2) \quad (\text{A13})$$

## REFERENCES

1. Ayre, Robert S.: Transient Response to Step and Pulse Functions. Basic Theory and Measurements. Vol. I of Shock and Vibration Handbook, Cyril M. Harris and Charles E. Crede, eds., McGraw-Hill Book Co., c.1961, pp. 8-1 to 8-54.
2. Jacobson, Lydik S.; and Ayre, R. S.: Engineering Vibrations. McGraw-Hill Book Co., Inc., 1958.
3. Rubin, Sheldon: Concepts in Shock Data Analysis. Data Analysis, Testing, and Methods of Control. Vol. 2 of Shock and Vibration Handbook, Cyril M. Harris and Charles E. Crede, eds., McGraw-Hill Book Co., c.1961, pp. 23-1 to 23-27.
4. Clevenson, Sherman A.; Martin, Dennis J.; and Pearson, Jerome: Representation of Transient Sinusoids in the Environmental Vibration Tests for Spacecraft. Annu. Tech. Meeting Proc., Inst. Environ. Sci., 1965, pp. 139-144.

TABLE I.- PHASOR CONSTANTS

$$P_i e^{j\phi_i} = (a_i + jb_i)^2 + c_i^2$$

$$P_i = \sqrt{(a_i^2 - b_i^2 + c_i^2)^2 + (2a_i b_i)^2}$$

$$\phi_i = \tan^{-1} \frac{2a_i b_i}{a_i^2 - b_i^2 + c_i^2}$$

i	$a_i$	$b_i$	$c_i$
1	$\zeta$	$p/\omega$	$\sqrt{1 - \zeta^2}$
2	$-\zeta$	$\sqrt{1 - \zeta^2}$	$\frac{p}{\omega} \left(1 - \frac{\nu}{p}\right)$
3	$\zeta$	$\frac{p}{\omega} \left(1 - \frac{\nu}{p}\right)$	$\sqrt{1 - \zeta^2}$
4	$-\zeta$	$\sqrt{1 - \zeta^2}$	$\frac{p}{\omega} \left(1 + \frac{\nu}{p}\right)$
5	$\zeta$	$\frac{p}{\omega} \left(1 + \frac{\nu}{p}\right)$	$\sqrt{1 - \zeta^2}$
6	$\alpha \frac{p}{\omega} - \zeta$	$\sqrt{1 - \zeta^2}$	$p/\omega$
7	$\frac{\zeta}{(p/\omega)} - \alpha$	1	$\frac{\sqrt{1 - \zeta^2}}{(p/\omega)}$

$$M_i e^{j\psi_i} = a_i^2 + jb_i^2$$

$$M_i = \sqrt{a_i^2 + b_i^2}$$

$$\psi_i = \tan^{-1} \frac{b_i}{a_i}$$

where  $a_i$  and  $b_i$  are:

i	$a_i$	$b_i$
1	$-\zeta$	$\sqrt{1 - \zeta^2}$
2	$-\alpha$	1
3	1	$2\zeta(p/\omega)$

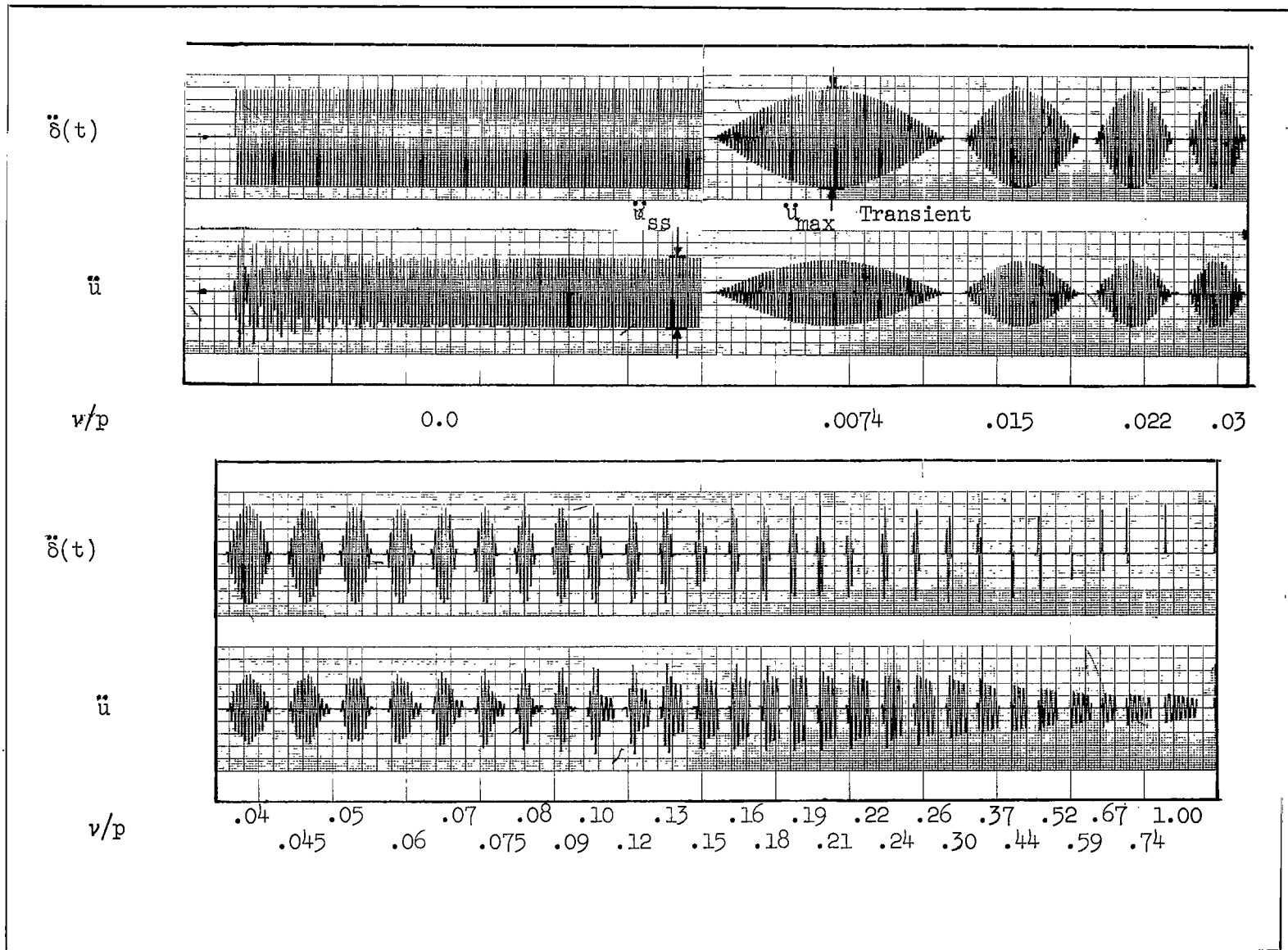

Figure 1.- Typical analog response curves for a simple mass system forced by a modulated sine function for  $\zeta = 0.01$  and  $\rho/\omega = 1.35$ .  $\ddot{\delta}(t) = A \sin pt \sin vt$ .

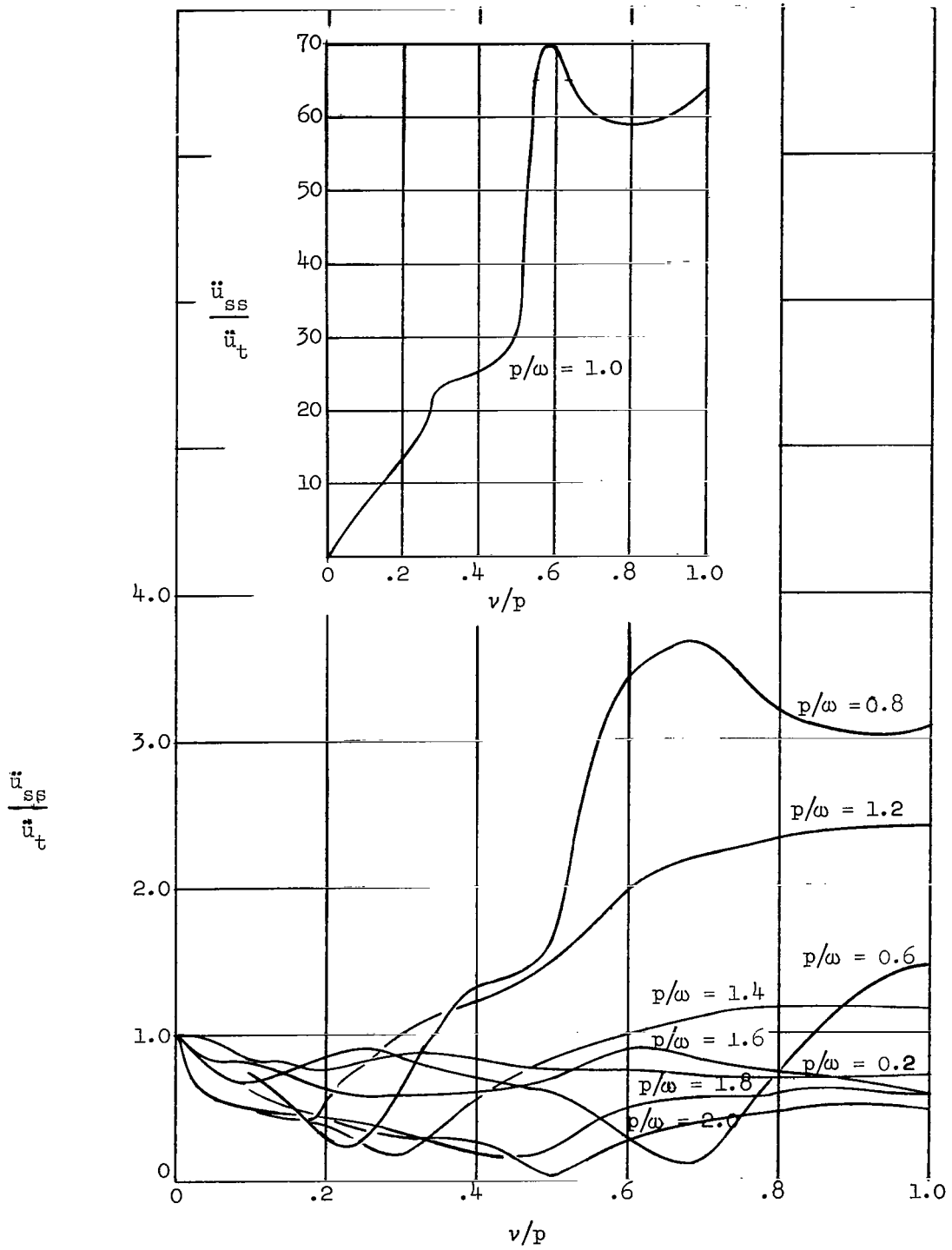
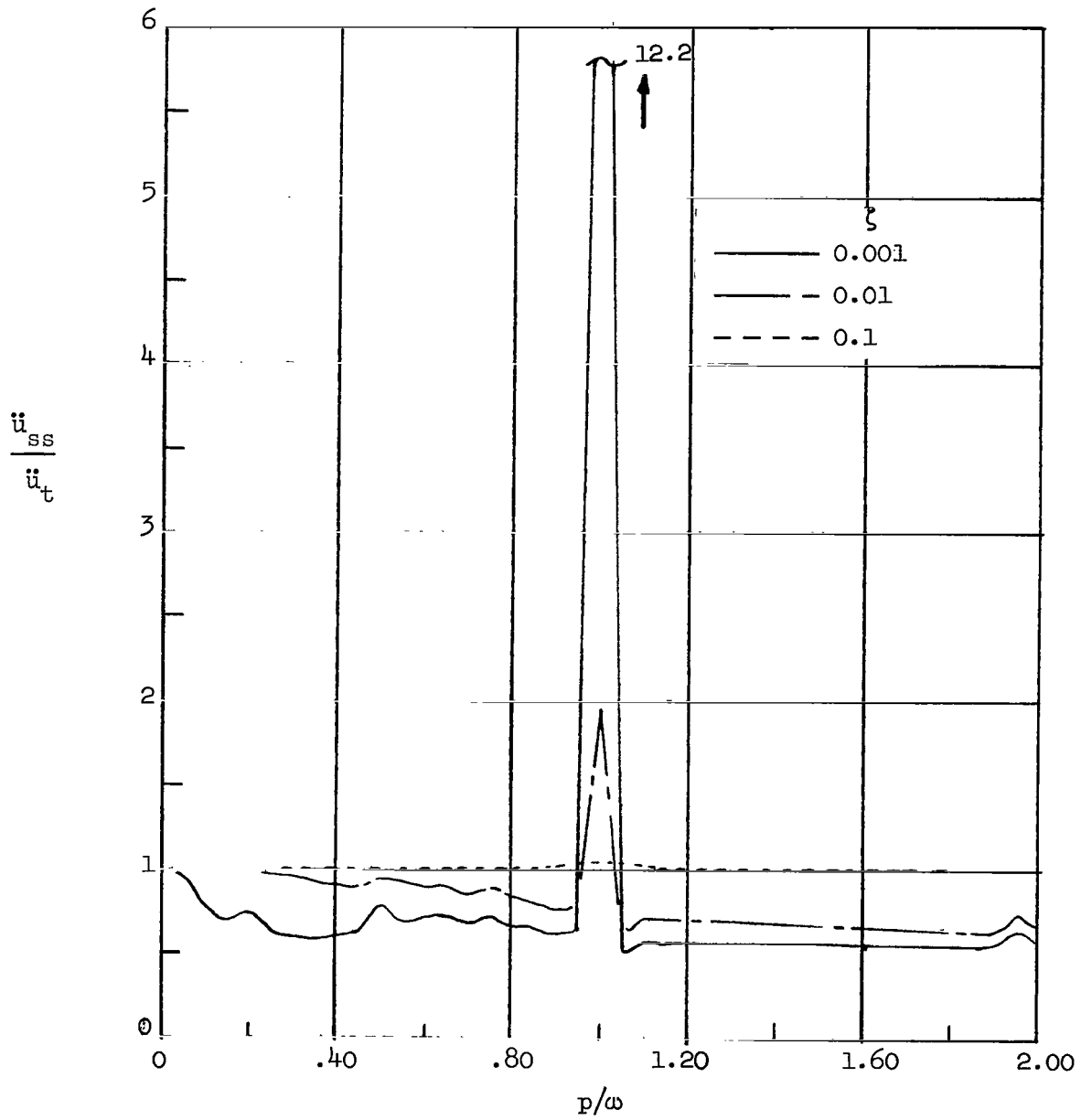

Figure 2.- Response ratios for modulated sine excitation showing effects of  $\nu/p$  and  $p/\omega$ .  $\zeta = 0.01$ .





(a)  $v/p = 0.02$ .

Figure 3.- Response ratios for modulated sine excitation showing effect of damping.

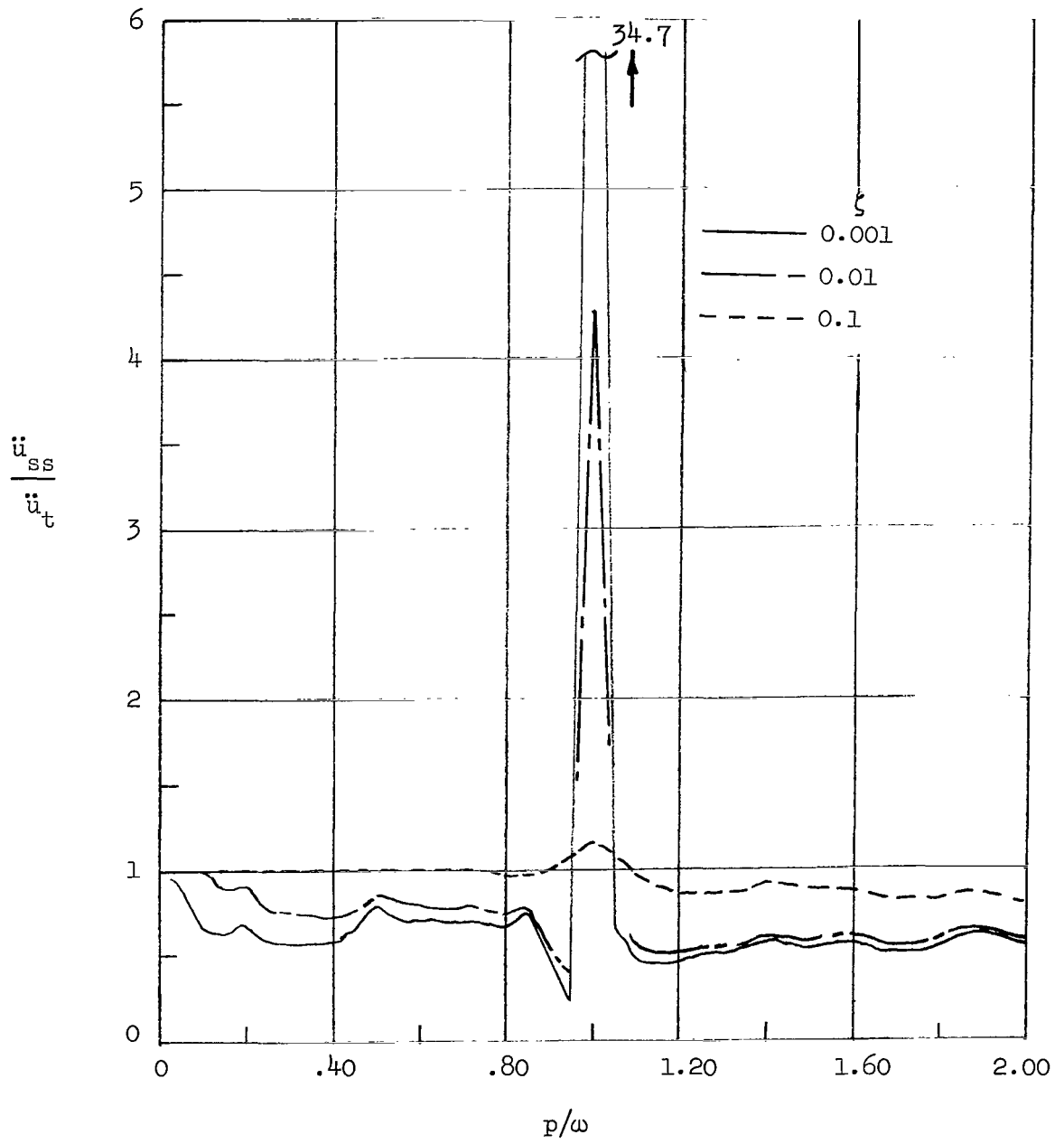

(b)  $v/p = 0.06$ .

Figure 3.- Continued.

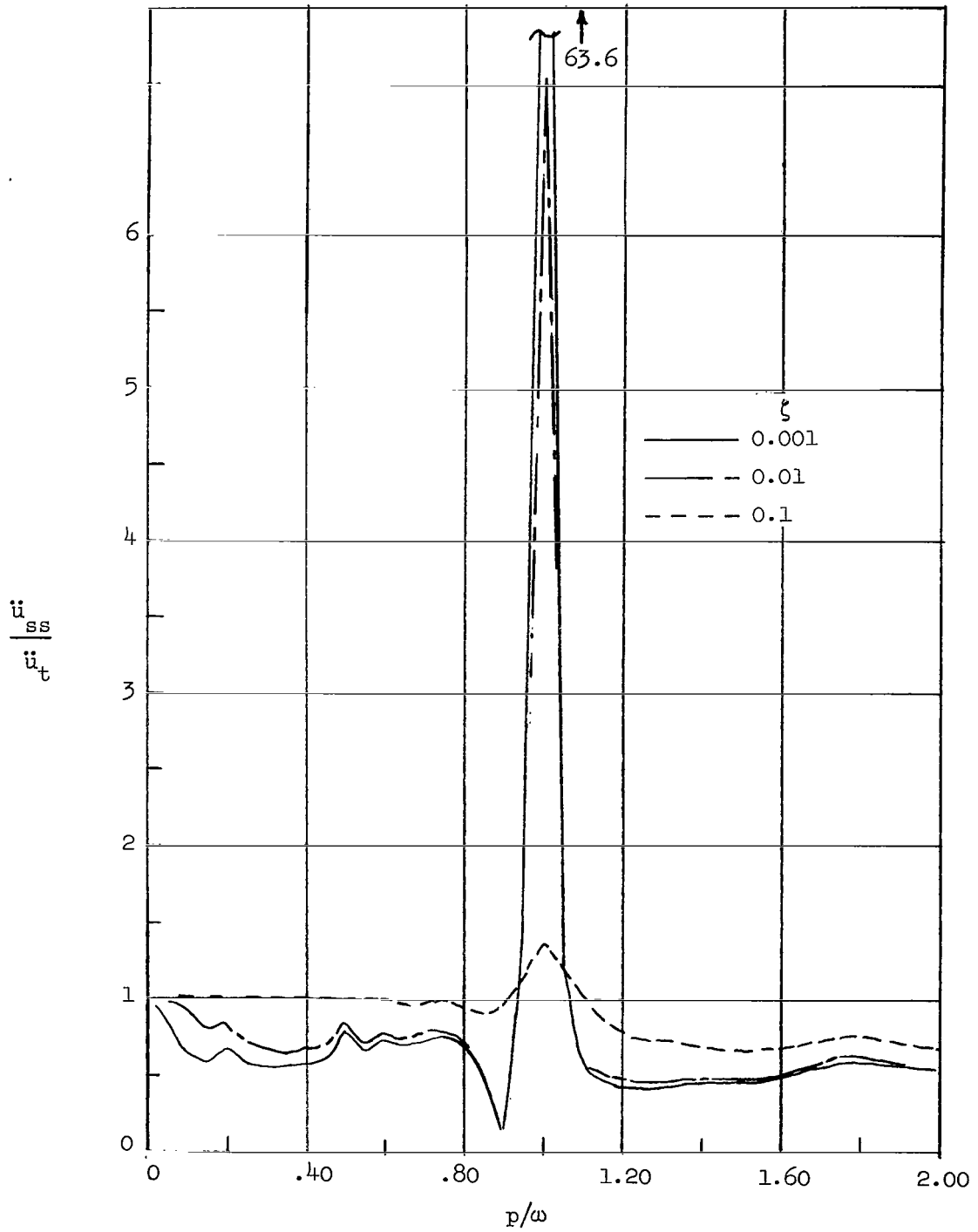

(c)  $\nu/p = 0.10$ .

Figure 3.- Concluded.

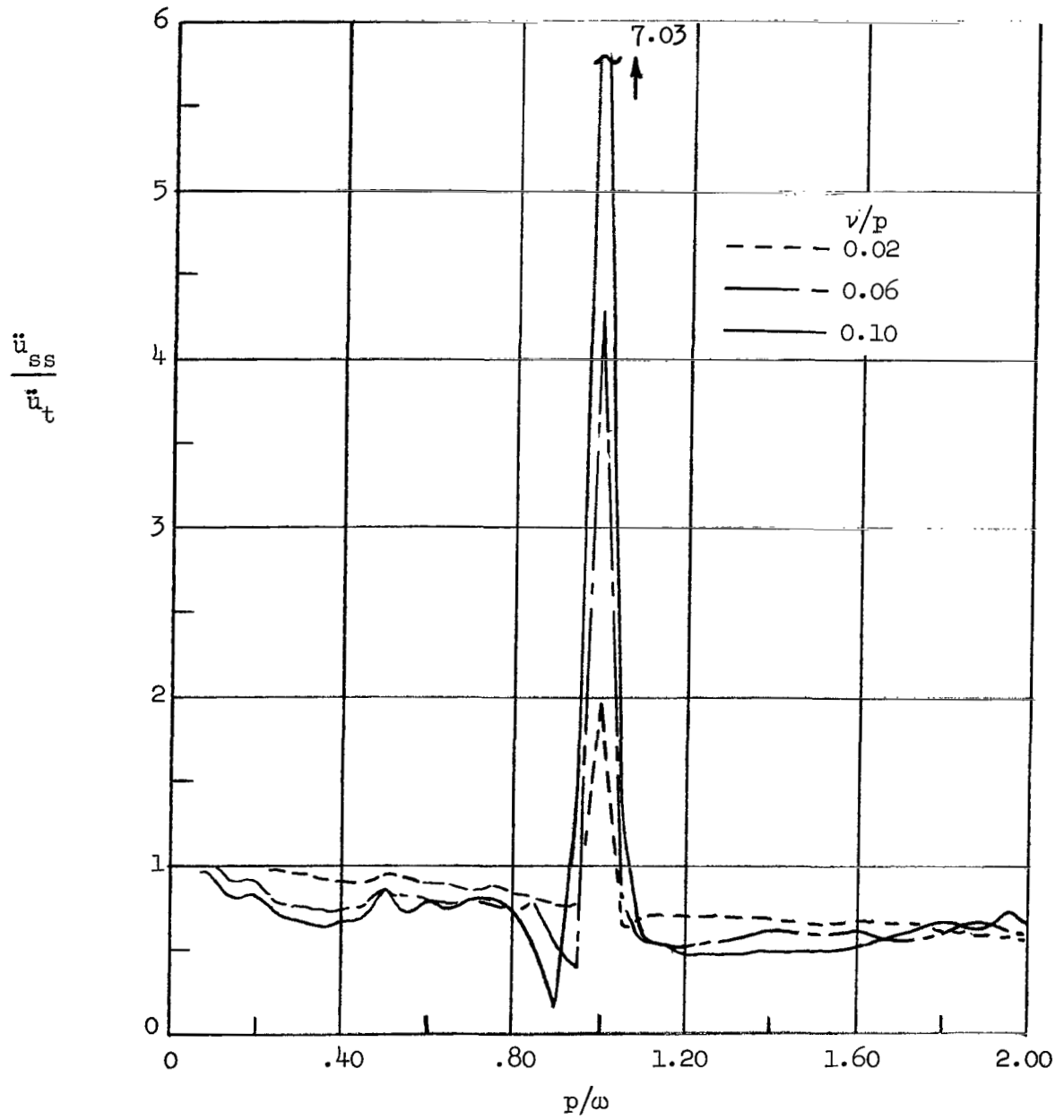

Figure 4.- Response ratios for modulated sine excitation showing effect of  $\nu/p$ .  $\zeta = 0.01$ .

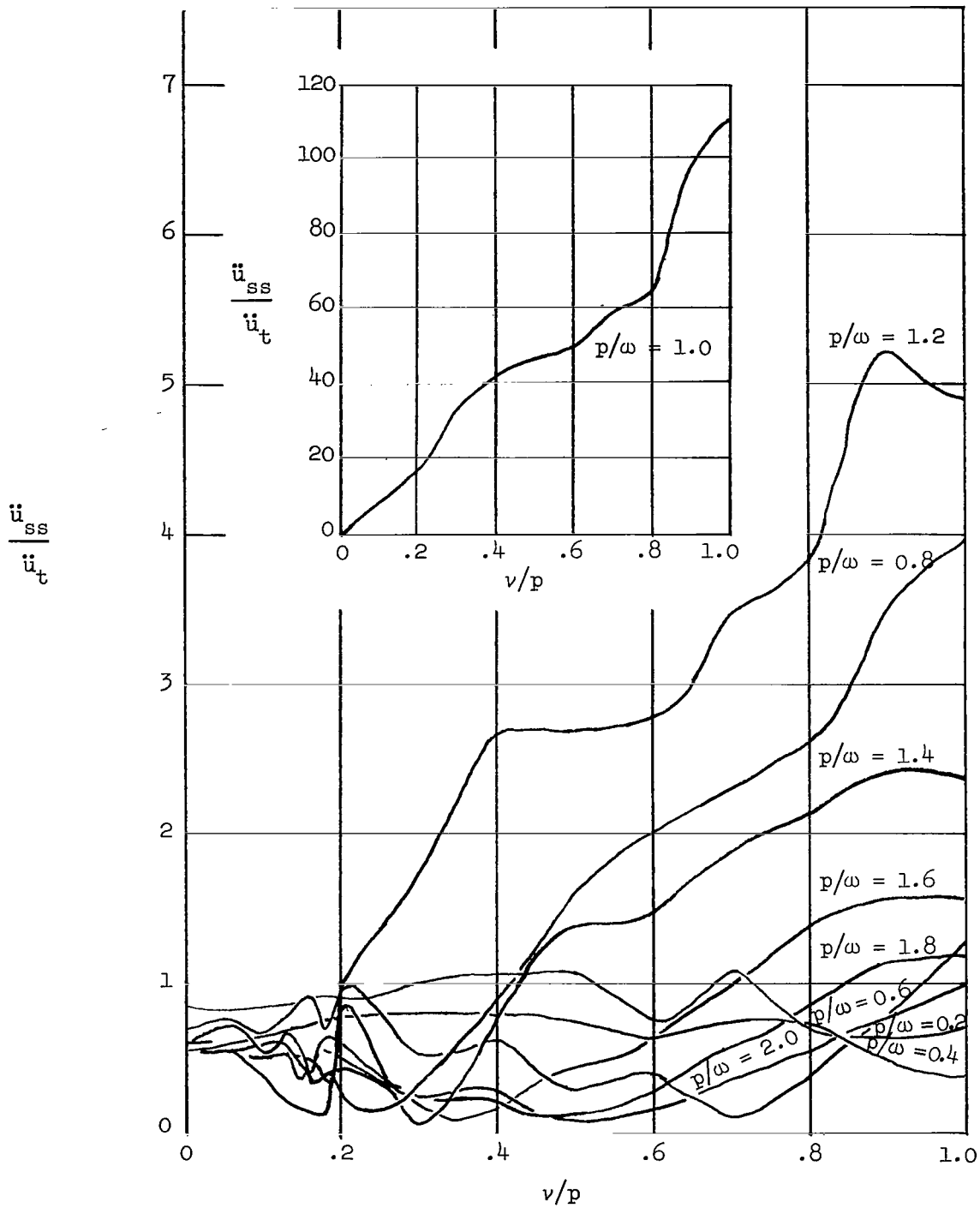
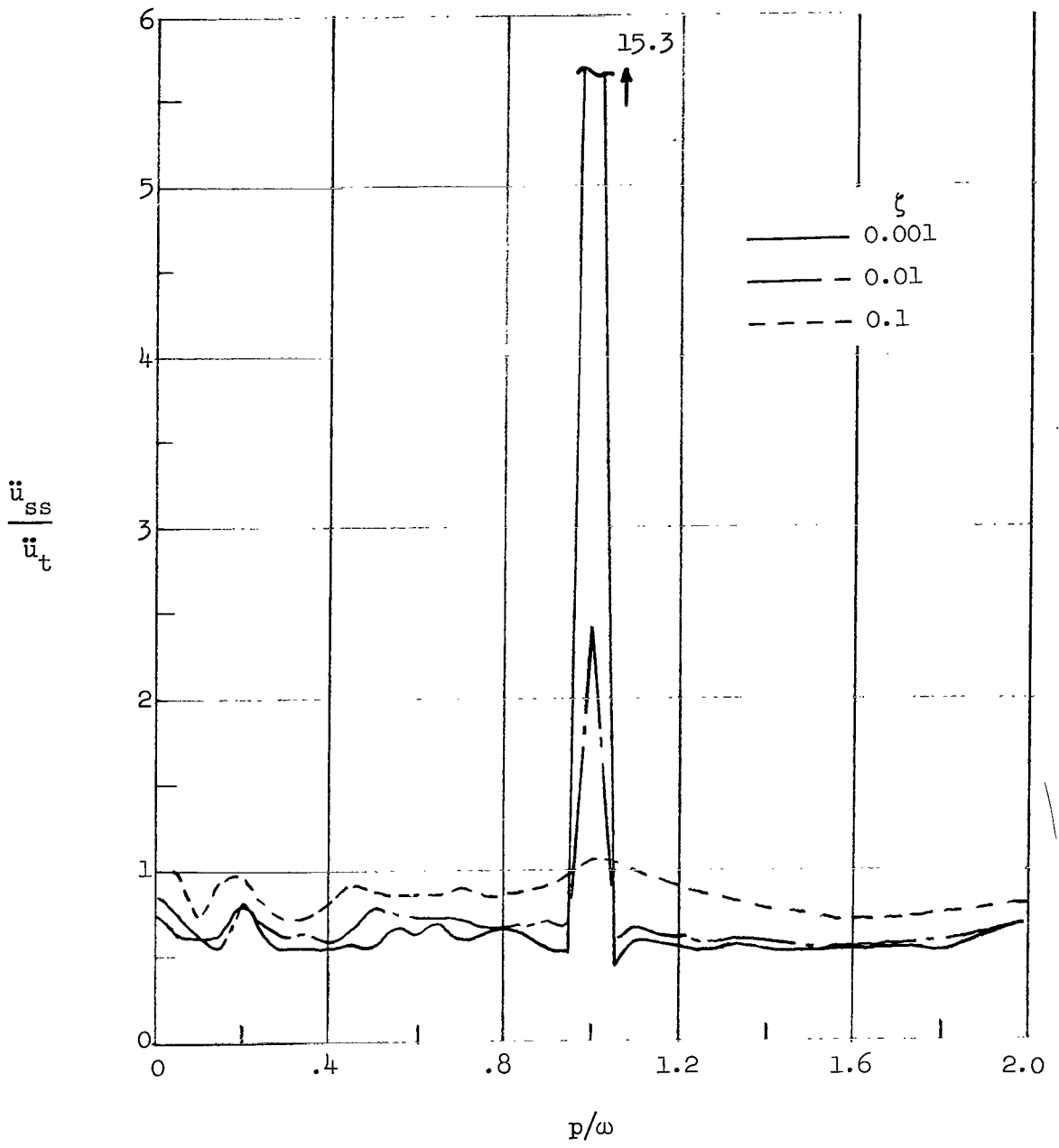
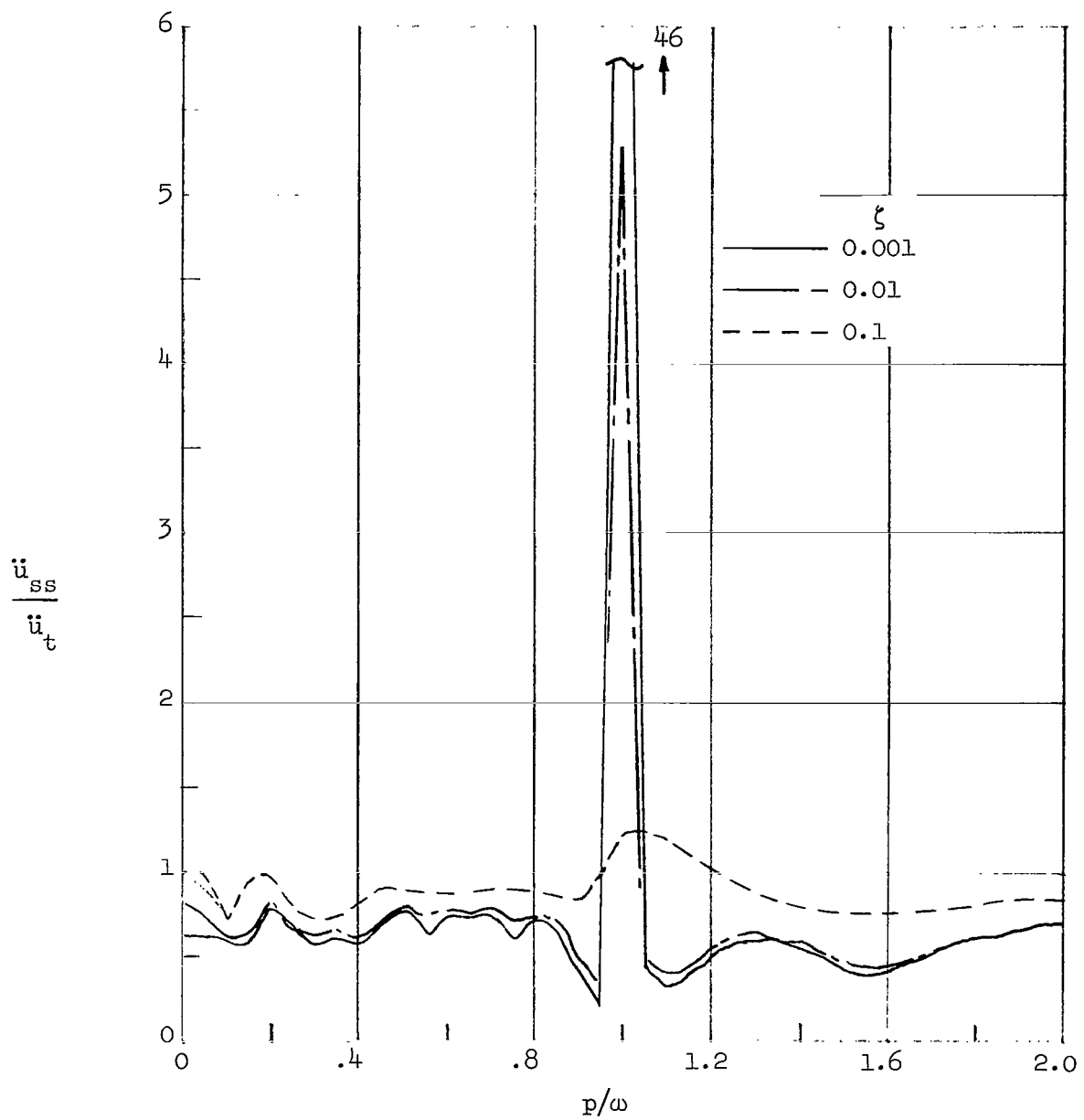

Figure 5.- Response ratios for modulating cosine excitation showing effects of  $v/p$  and  $p/\omega$ .  $\zeta = 0.01$ .



(a)  $\nu/\rho = 0.02$ .

Figure 6.- Response ratios for modulated cosine excitation showing effect of damping.



(b)  $v/p = 0.06$ .

Figure 6.- Continued.

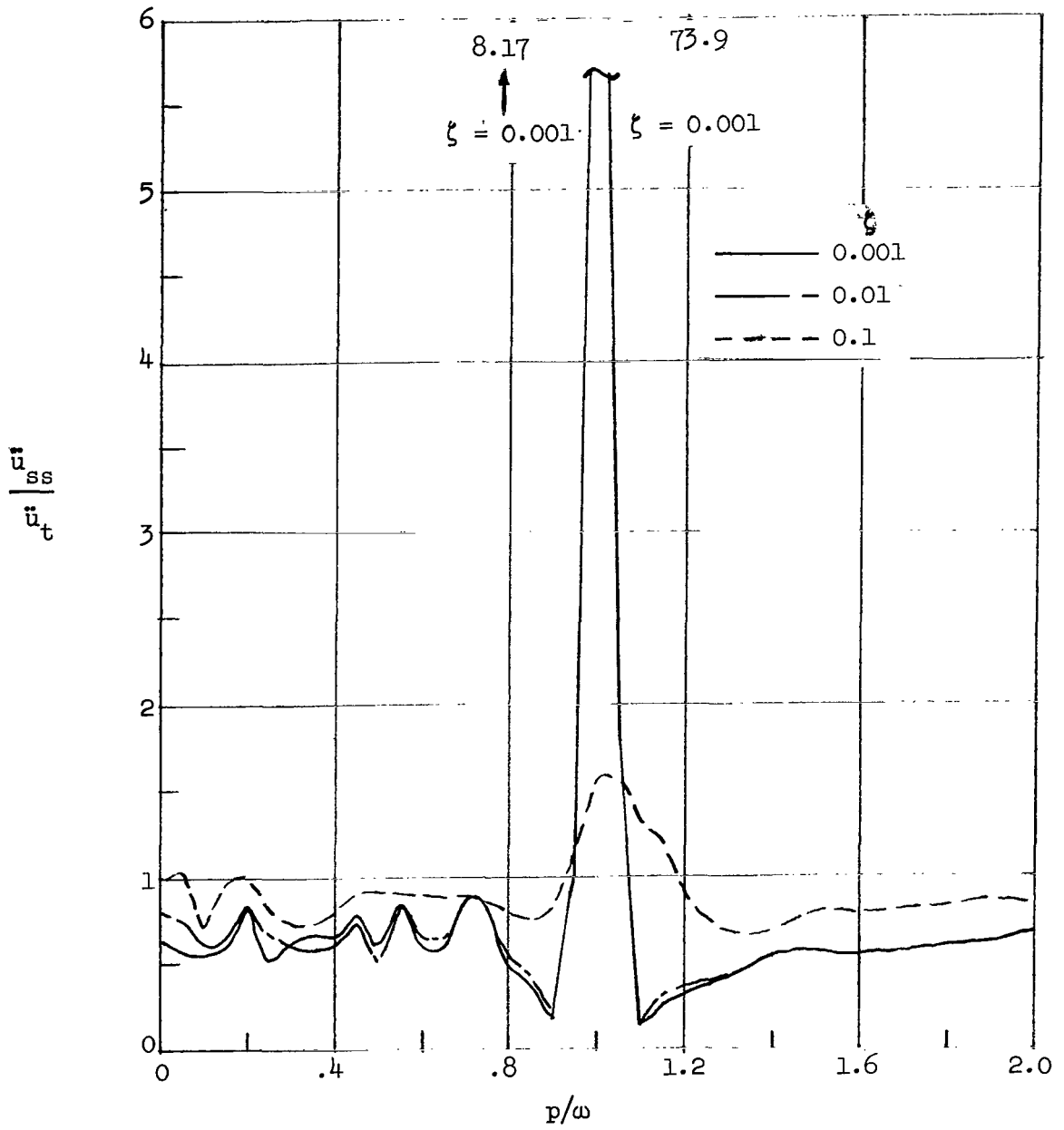

(c)  $v/p = 0.10$ .

Figure 6.- Concluded.



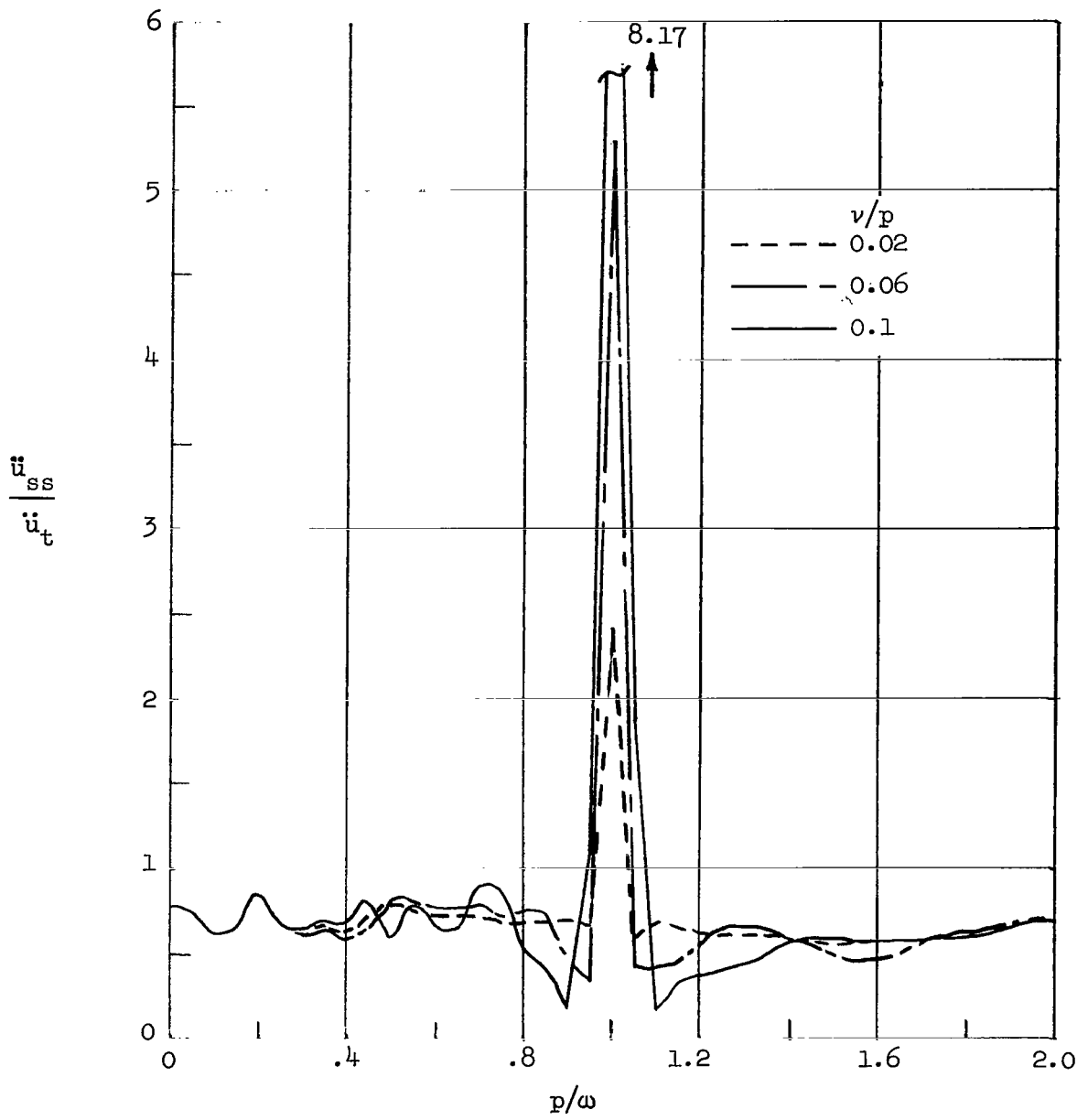

Figure 7.- Response ratios for modulated cosine excitation showing effect of  $v/p$ .  $\zeta = 0.01$ .

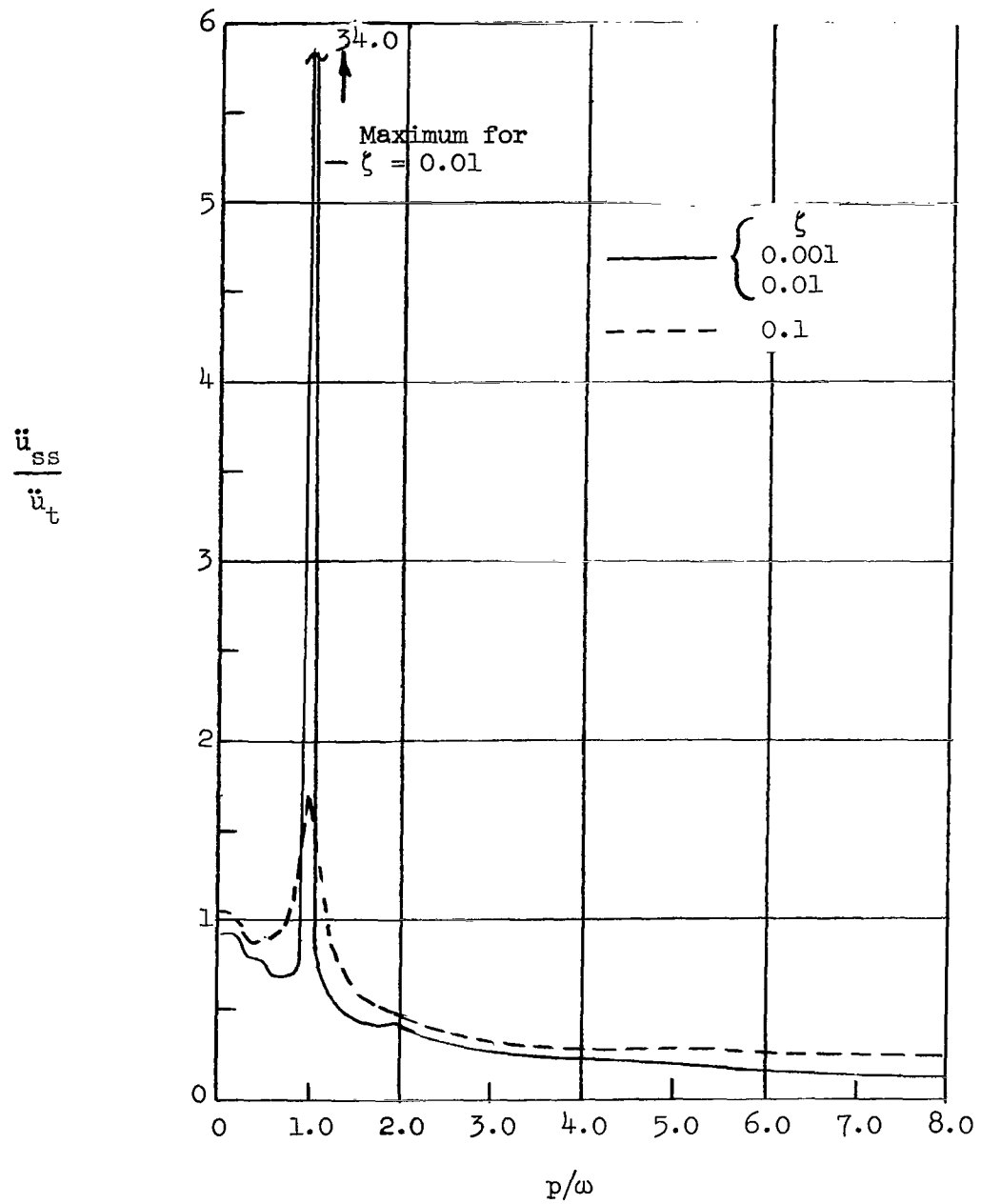

Figure 8.- Response ratios for damped sinusoid excitation showing effect of damping.  $\alpha = 0.03$ .

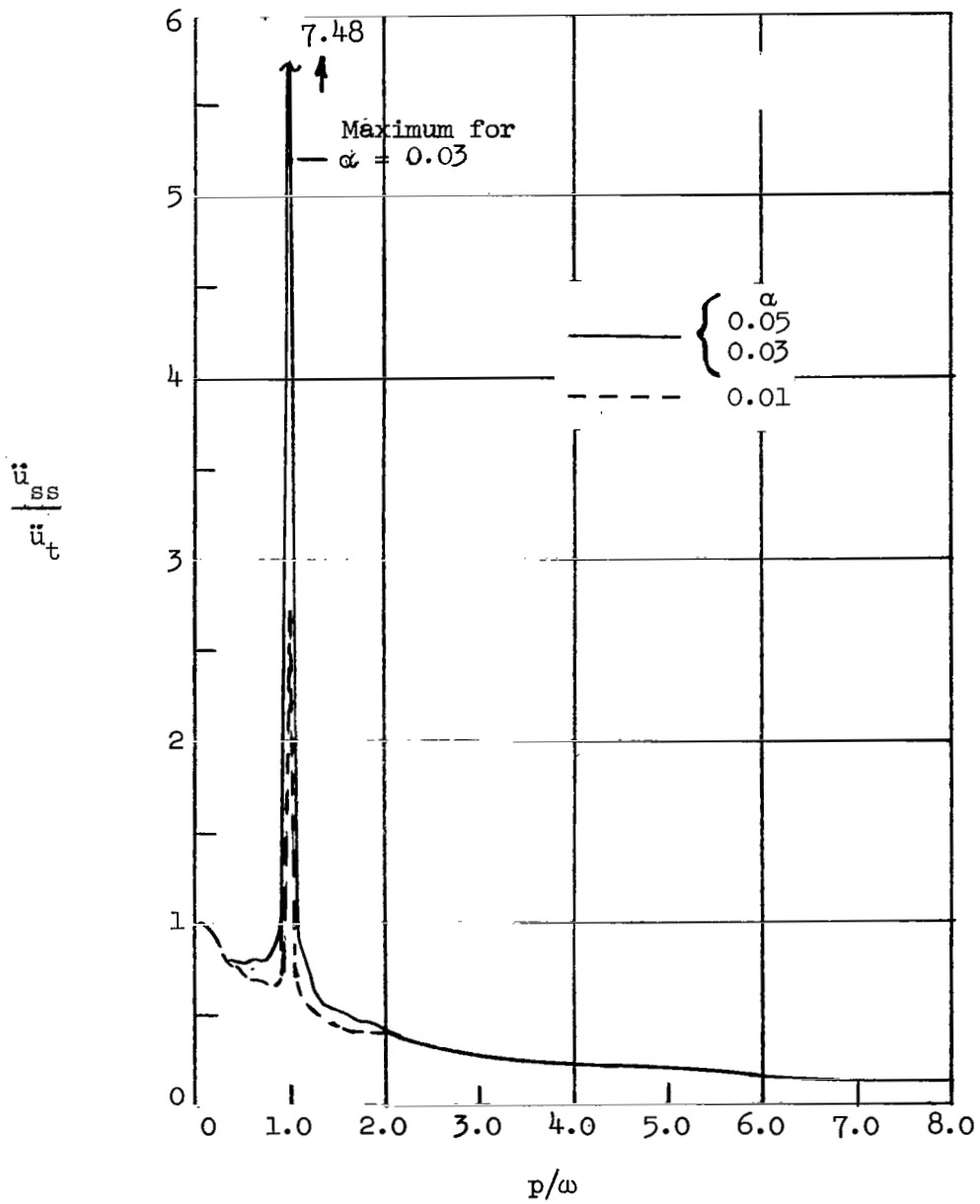

Figure 9.- Response ratios for damped sinusoidal excitation showing effect of excitation decay ratio  $\alpha$ .  $\zeta = 0.01$ .

FIRST CLASS MAIL

POSTMASTER: If Undeliverable (Section 158  
Postal Manual) Do Not Return

*"The aeronautical and space activities of the United States shall be conducted so as to contribute . . . to the expansion of human knowledge of phenomena in the atmosphere and space. The Administration shall provide for the widest practicable and appropriate dissemination of information concerning its activities and the results thereof."*

— NATIONAL AERONAUTICS AND SPACE ACT OF 1958

## NASA SCIENTIFIC AND TECHNICAL PUBLICATIONS

**TECHNICAL REPORTS:** Scientific and technical information considered important, complete, and a lasting contribution to existing knowledge.

**TECHNICAL NOTES:** Information less broad in scope but nevertheless of importance as a contribution to existing knowledge.

**TECHNICAL MEMORANDUMS:** Information receiving limited distribution because of preliminary data, security classification, or other reasons.

**CONTRACTOR REPORTS:** Scientific and technical information generated under a NASA contract or grant and considered an important contribution to existing knowledge.

**TECHNICAL TRANSLATIONS:** Information published in a foreign language considered to merit NASA distribution in English.

**SPECIAL PUBLICATIONS:** Information derived from or of value to NASA activities. Publications include conference proceedings, monographs, data compilations, handbooks, sourcebooks, and special bibliographies.

**TECHNOLOGY UTILIZATION PUBLICATIONS:** Information on technology used by NASA that may be of particular interest in commercial and other non-aerospace applications. Publications include Tech Briefs, Technology Utilization Reports and Notes, and Technology Surveys.

*Details on the availability of these publications may be obtained from:*

**SCIENTIFIC AND TECHNICAL INFORMATION DIVISION  
NATIONAL AERONAUTICS AND SPACE ADMINISTRATION  
Washington, D.C. 20546**