

NASA TECHNICAL NOTE



NASA TN D-5192

NASA TN D-5192

EXPERIMENTS ON ROTATING EXTERNALLY
PRESSURIZED AIR JOURNAL BEARINGS

II - Attitude Angle and Air Flow

*by Robert E. Cunningham, David P. Fleming,
and William J. Anderson*

*Lewis Research Center
Cleveland, Ohio*

EXPERIMENTS ON ROTATING EXTERNALLY
PRESSURIZED AIR JOURNAL BEARINGS

II - Attitude Angle and Air Flow

By Robert E. Cunningham, David P. Fleming,
and William J. Anderson

Lewis Research Center
Cleveland, Ohio

NATIONAL AERONAUTICS AND SPACE ADMINISTRATION

ABSTRACT

Experimental attitude angles and airflow are compared with theory for a pair of $2\frac{1}{2}$ -inch (6.3-cm) diameter by $3\frac{3}{4}$ -inch (9.5-cm) long externally pressurized air bearings. Attitude angles vary with shaft speed as predicted by small-eccentricity pressure perturbation theory but are generally larger in magnitude. The attitude-eccentricity locus of the journal center for a supply pressure ratio of 1.7 is similar to that of a plain self-acting bearing. Measured airflows were in excellent agreement with calculated values. Shaft speeds varied from 0 to 25 000 rpm, and radial loads varied up to 20.2 psi (139 kN/m^2). The supply pressure range covered was approximately 24 to 88 psia (169 to 610 kN/m^2).

EXPERIMENTS ON ROTATING EXTERNALLY PRESSURIZED AIR JOURNAL BEARINGS

II - ATTITUDE ANGLE AND AIR FLOW

by Robert E. Cunningham, David P. Fleming,
and William J. Anderson

Lewis Research Center

SUMMARY

Experimental attitude angles and gas weight flows are measured and compared with theoretical values for a pair of $2\frac{1}{2}$ -inch (6.3-cm) diameter, $3\frac{3}{4}$ -inch (9.5-cm) long externally pressurized air lubricated bearings. Results show that attitude angles vary with shaft speed as predicted by the small-eccentricity perturbation theory but are generally larger in magnitude. The attitude eccentricity locus of the journal center for a supply pressure ratio of 1.7 is similar to that of a plain self-acting bearing.

Excellent agreement was obtained between measured values of airflow through the bearing and those determined analytically. The speed range covered in these experiments was 0 to 25 000 rpm and radial loads were varied from 0 to 189 pounds (840 N) per bearing or 20.2 psi (139 kN/m^2). Bearing supply pressures were varied from 24 to 88 psia (169 to 610 kN/m^2).

INTRODUCTION

Experimental results for load capacity and stiffness of an orifice compensated, externally pressurized bearing are reported in part I of this investigation (ref. 1). These results are compared with the small eccentricity, linearized PH and the small-eccentricity pressure perturbation theories (refs. 2 and 3).

The effect of load and rotation on journal locus is well documented both experimentally and analytically for the plain self-acting journal bearing (refs. 4 and 5). The analyses of references 2 and 3 may be used to determine attitude angles for rotating externally pressured bearings. However, little experimental information of this kind is available. In addition, for this bearing design to be considered in machines operating in a closed-loop cycle, something of the flow requirements must be known. The flow rates

and pressures required to support a given load will determine the power that has to be supplied by a compressor. Analytical flow rates are given by reference 7, which is similar to the analyses of references 2 and 3. Because of the approximations made in the analyses, the validity and range of applicability of the results must be checked experimentally.

The objectives of part II of this investigation are (1) to determine the effects of load and shaft speed on bearing attitude angles while varying the supply pressure, (2) to measure the mass flow rates through the bearing, and (3) to compare these results with those obtained from analysis.

The results reported in this investigation were obtained with a pair of $2\frac{1}{2}$ -inch (6.3-cm) diameter, $3\frac{3}{4}$ -inch (9.5-cm) long orifice compensated, externally pressurized air lubricated bearings. The rotor was operated in the two bronze bearings at an average radial clearance of 0.00135 inch (0.034 mm). Rotor speeds were varied from 0 to 25 000 rpm which corresponds to a range of compressibility number Λ of 0 to 2.8. Externally applied unidirectional loading varied up to 189 pounds (840 N) per bearing or 20.2 psi (139 kN/m²) of projected area. Air supply pressure ratios P_s/P_a varied from 1.7 to 6.

APPARATUS AND PROCEDURE

The experimental data for this investigation were obtained with the apparatus shown in the photograph of figure 1. A detailed description can be found in part I (ref. 1).

One of the bronze test bearings and the rotor used in this study are shown in figure 2. Each of the bearings has 12 orifice plugs arranged in two circumferential rows of six. The manner in which the orifice plugs are mounted is shown schematically in the section view (fig. 3(a)). The relation of the restrictor length to diameter ratio is shown in the enlarged detail of figure 3(b).

The procedure used in obtaining the data reported herein is basically the same as that outlined in part I (ref. 1). In addition, the flow measurements for both upper and lower bearings were measured using a calibrated flowmeter and were recorded. Readings were made at each change in the supply pressure to the bearings with the rotor in a concentric position (unloaded). Eccentricity and attitude angle were determined from the capacitance probe readings.

Photographs of the rotor attitude-eccentricity locus were also made by taking successive exposure of the same film at each new load increment.

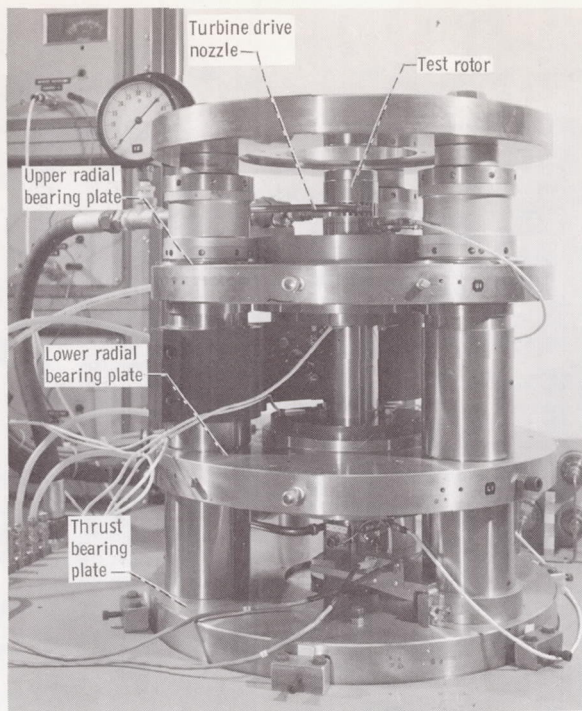

(a) Photograph

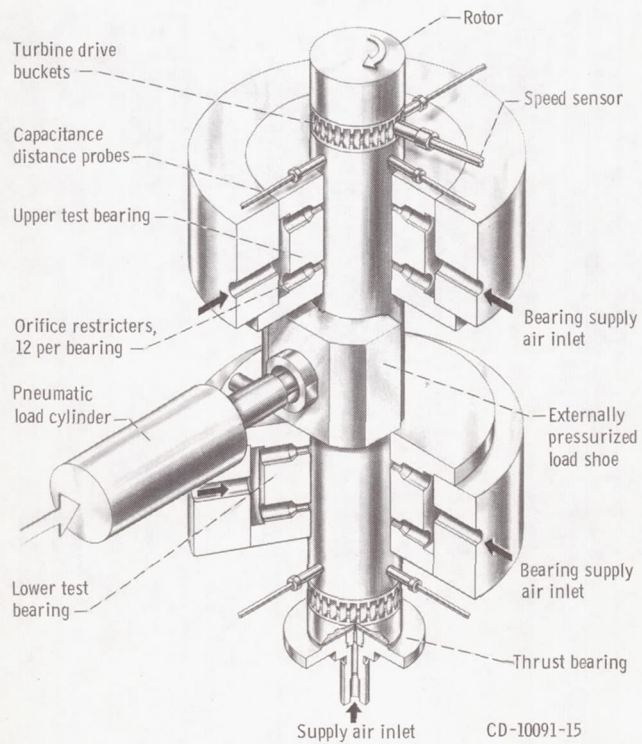

(b) Schematic.

Figure 1. - Externally pressurized air bearing test apparatus.



C-68-1924

Figure 2. - Test bearing and rotor.

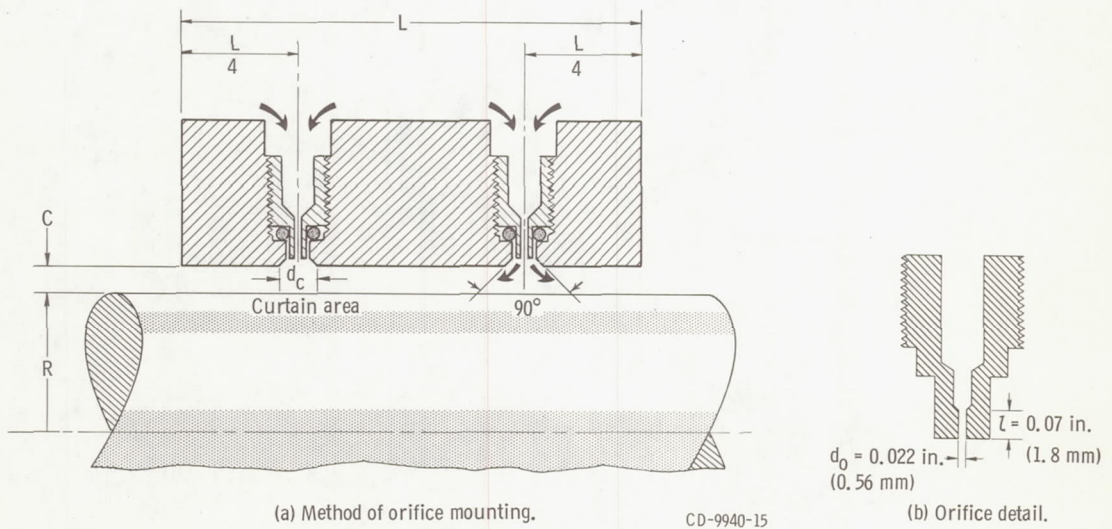

Figure 3. - Section view of test bearing.

RESULTS AND DISCUSSION

Bearing attitude angle is defined as the angle in the direction of rotation, between the load vector and the bearing-journal line of centers (fig. 4). The results of this investigation are plotted in figures 5 to 7. A comparison is made in figure 5 of attitude angle against eccentricity ratios at increasing supply pressures. These curves show that there is a decrease in bearing attitude angle with increasing supply pressures at a given eccentricity ratio and compressibility number. This illustrates the decreasing contribution of rotational or self-acting effects on the overall hybrid performance as supply pressure increases. It appears, however, that as long as there is any journal rotation, the attitude angle will always be appreciably greater than for the zero-speed case (i. e. , zero attitude angle at any eccentricity ratio). The small orbits seen in the photograph of figure 5(d) are due to rotor imbalance. The near circular orbits at low eccentricities flatten out at higher eccentricities because of the asymmetric film stiffness.

The plot of figure 5(a) compares the experimental journal locus of the externally pressurized bearing to that of a plain self-acting bearing. The theoretical curve was produced from the data of reference 5 for a bearing with an L/D of 1.5. In addition to having a smaller attitude angle at smaller eccentricity ratios, attitude angle is more nearly constant in the externally pressurized bearing. The rather large attitude angles for the externally pressurized bearing again illustrate the predominance of self-acting characteristics at low supply pressure.

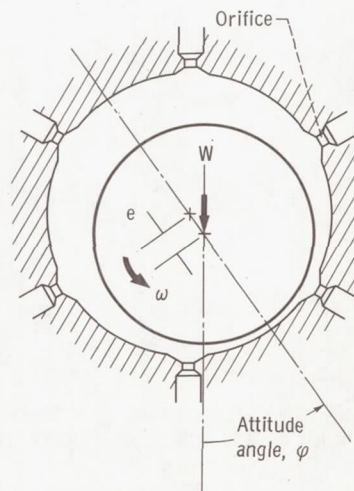
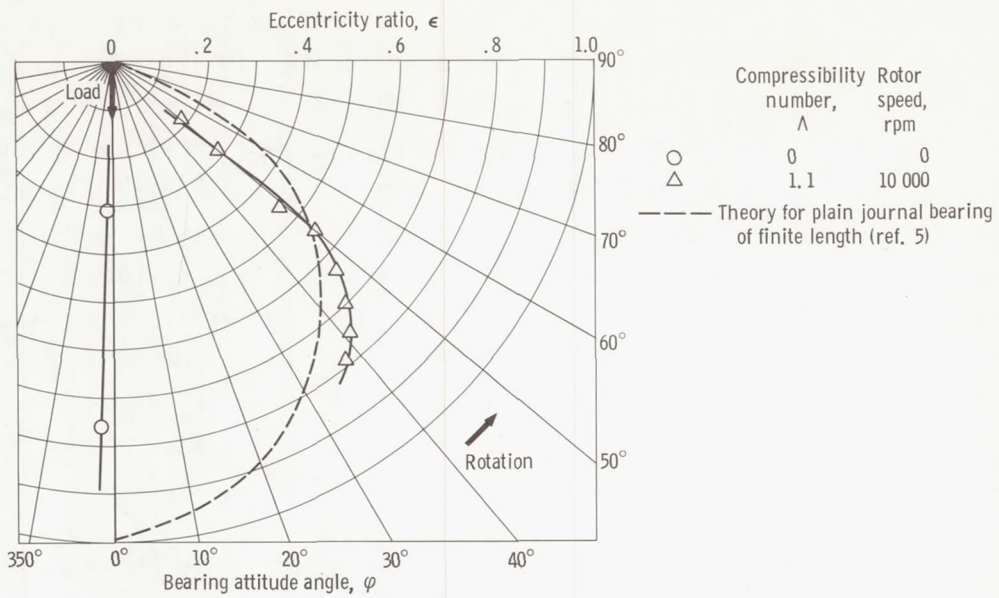
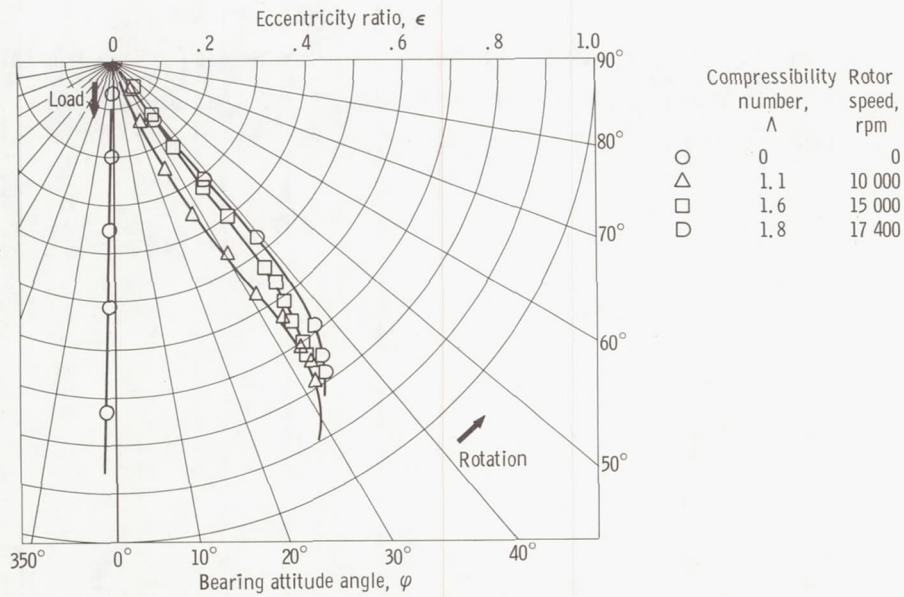

Figure 4. - Representation of bearing attitude angle.



(a) Air supply pressure ratio, 1.7.



(b) Air supply pressure ratio, 2.3.

Figure 5. - Attitude angle versus eccentricity ratio. Bearing average radial clearance, 0.00135 inch (0.0034 mm); rotor diameter, 2.5 inch (6.3 cm); bearing length, 3.75 inch (9.5 cm); number of orifices, 12; orifice diameter, 0.022 inch (0.56 mm).

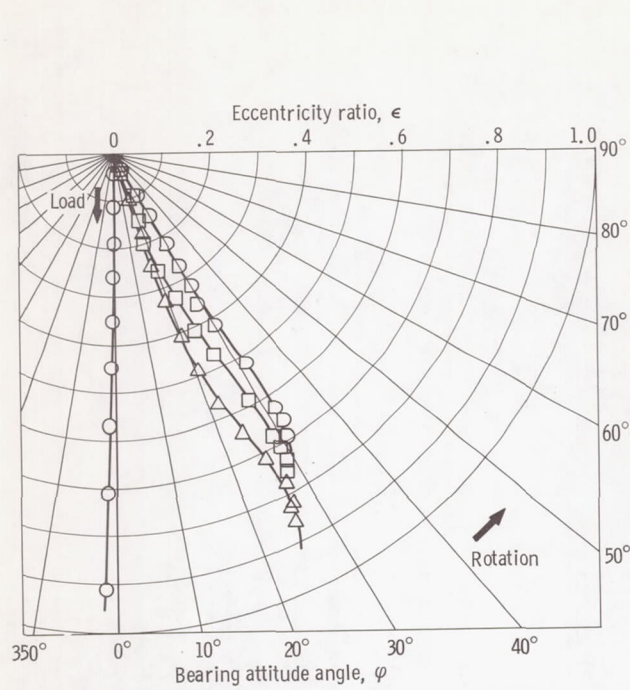

(c) Air supply pressure ratio, 2.9.

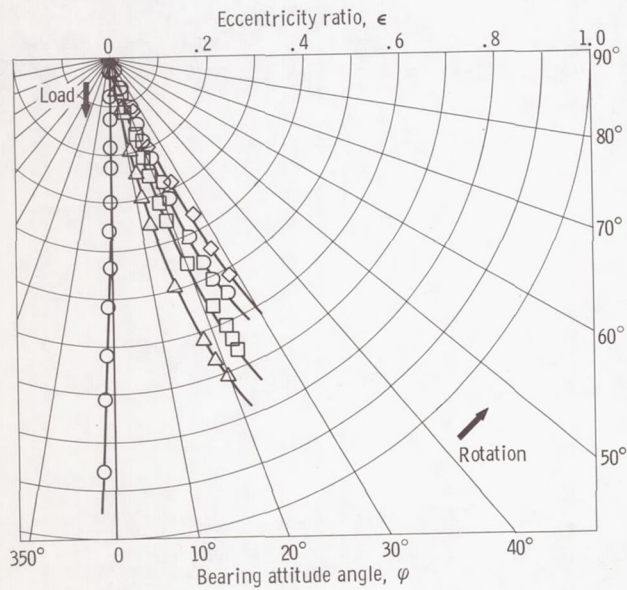
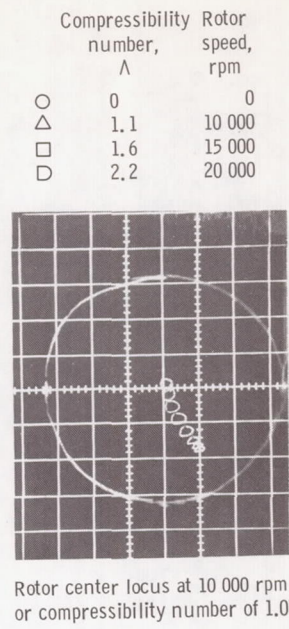

(d) Air supply pressure ratio, 3.6.

Figure 5. - Continued.

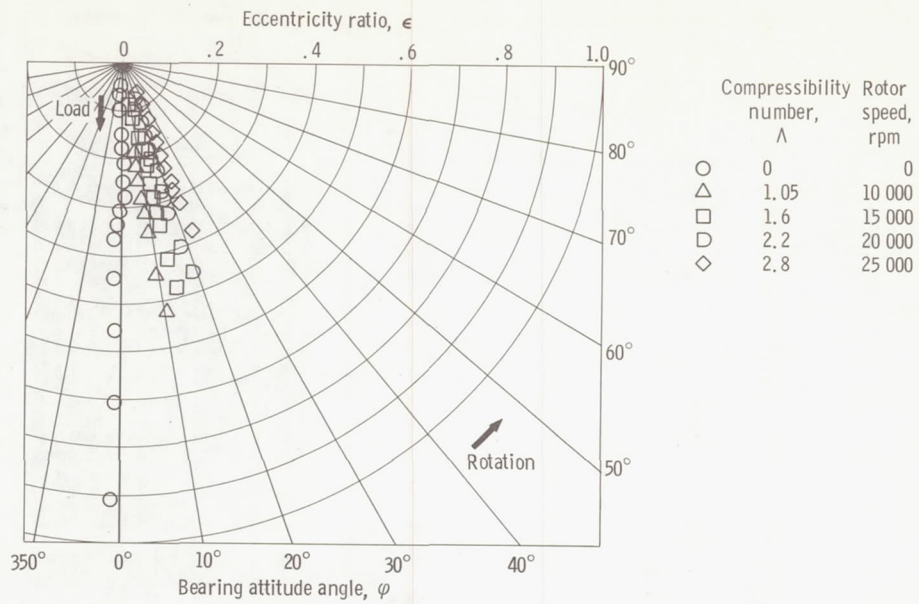

(e) Air supply pressure ratio, 4.8.

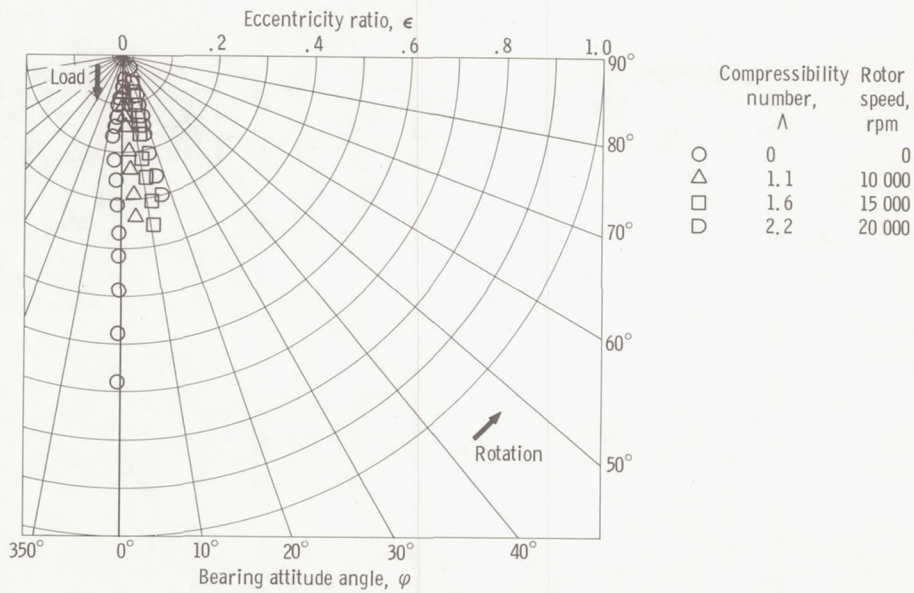

(f) Air supply pressure ratio, 6.0.

Figure 5. - Concluded.

Figure 6 shows the variation of experimental attitude angles with compressibility number at an eccentricity ratio ϵ of 0.1. Also plotted are analytical predictions, obtained from the computer program in reference 7. At all supply pressures investigated the measured attitude angles are greater than the small-eccentricity pressure perturbation theory predicts. This is not surprising, however, since this bearing has only six orifices per row. A greater number of orifices, of course, would more closely approximate the line pressure source assumed by theory.

The computer program of reference 7 was also used to calculate the airflow through the bearings. The orifice discharge coefficients used to calculate the theoretical flow were obtained from experimental data reported in reference 6. As shown in figure 7 measured airflow (rotor concentric in bearing) was in excellent agreement with the calculated values. This undoubtedly is due to using values of the discharge coefficient which vary with supply pressure. Values of airflow measured for the eccentric case (radial load applied to shaft) did not vary significantly from the concentric case.

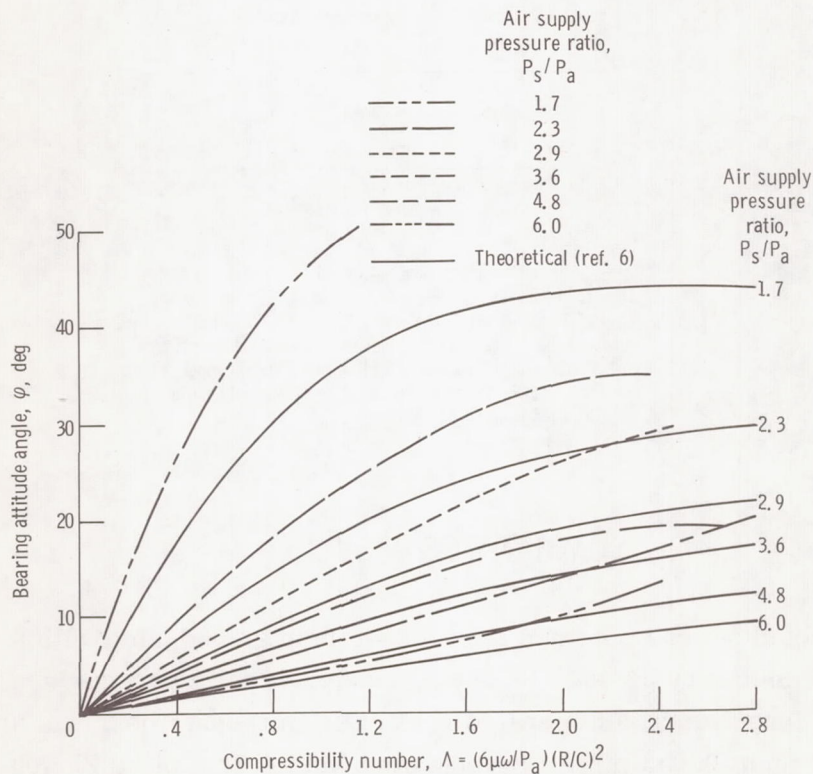

Figure 6. - Bearing attitude versus compressibility numbers at varying supply pressure ratios. Rotor eccentricity ratio, 0.1; bearing average radial clearance, 0.00135 inch (0.034 mm); rotor diameter, 2.5 inches (6.3 cm); bearing length, 3.75 inches (9.5 cm); number of orifices, 12; orifice diameter, 0.022 inch (0.56 mm).

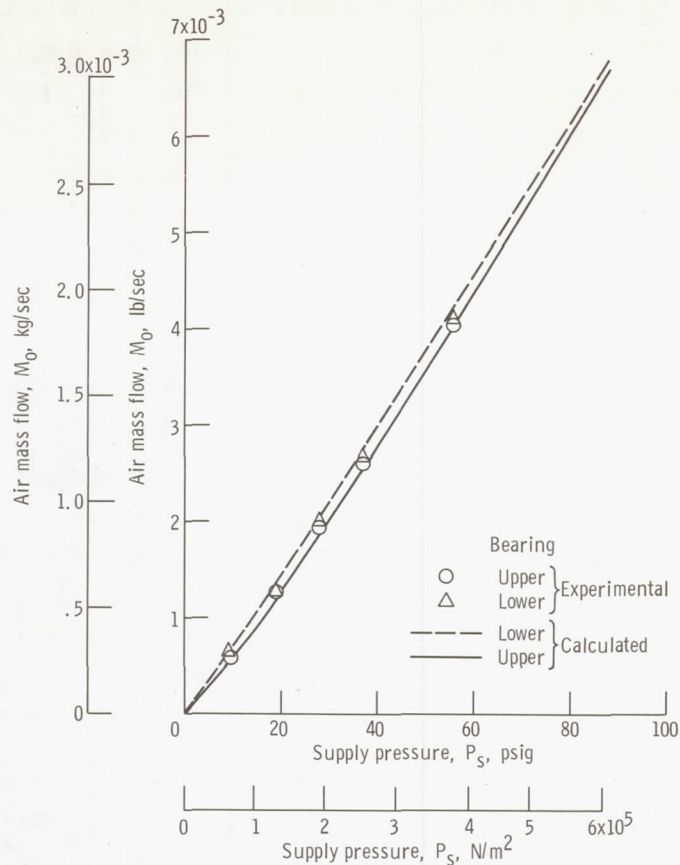

Figure 7. - Comparison of calculated and experimental values of air mass flow. Atmospheric pressure, 14.4 psia (99 kN/m²); rotor diameter, 2.5 inches (6.3 cm); bearing length, 3.75 inches (9.5 cm); number of orifices per bearing, 12; orifice diameter, 0.022 inch (0.56 mm). Radial clearances: upper bearing, 0.00132 inch (0.0335 mm); lower bearing, 0.00138 inch (0.035 mm).

SUMMARY OF RESULTS

The following results were obtained from experiments conducted with a pair of $2\frac{1}{2}$ -inch (6.3-cm) diameter by $3\frac{3}{4}$ -inch (9.5-cm) long externally pressurized air bearings. An 18-inch (46-cm) long rotor was operated vertically in the two bearings at a radial clearance of 0.0013 inch (0.033 mm). Speeds were varied from 0 to 25 000 rpm and radial loads up to 189 pounds per bearing or 20.2 psi (840 N or 139 kN/m²). Air supply pressure ratios P_s/P_a varied from 1.7 to 6.

1. Attitude angles at small eccentricity ratios vary with shaft speed in the same manner as predicted by small-eccentricity perturbation theory.
2. Attitude angles are, in general, larger than the theory predicts.

3. The journal locus of an externally pressurized bearing at an air supply pressure ratio of 1.7 is similar to that of a plain self-acting journal bearing.

4. Excellent agreement was obtained between measured and calculated weight flows of air.

Lewis Research Center,

National Aeronautics and Space Administration,

Cleveland, Ohio, February 25, 1969,

129-03-13-05-22.

APPENDIX - SYMBOLS

C	bearing radial clearance, in.; mm	P_s	bearing supply pressure, psi; N/m^2
D	rotor diameter, in.; cm	R	rotor radius, in.; cm
d_o	orifice diameter, in.; mm	W	applied radial load, lb; N
e	rotor eccentricity, in.; mm	ϵ	rotor eccentricity ratio, e/C
L	bearing length, in.; cm	Λ	bearing compressibility number, $(6\mu\omega/P_a)/(R/C)^2$
n	number of orifices	μ	absolute viscosity, (lb)(sec)/in. ² ; $(N)(sec)/m^2$
M_o	lubricant mass flow, lb/sec; kg/sec	ω	rotor angular speed, rad/sec
N	rotor angular speed, rpm	ϕ	bearing attitude angle, deg
P_a	atmospheric pressure, psi; N/m^2		

REFERENCES

1. Cunningham, Robert E.; Fleming, David P.; and Anderson, William J.: Experiments on Rotating Externally Pressurized Journal Bearings. I - Load Capacity and Stiffness. NASA TN D-5191, 1969.
2. Lund, J. W.: A Theoretical Analysis of Whirl Instability and Pneumatic Hammer for a Rigid Rotor in Pressurized Gas Journal Bearings. J. Lubr. Tech., vol. 89, no. 2, Apr. 1967, pp. 154-166.
3. Lund, J. W.: The Hydrostatic Gas Journal Bearing with Journal Rotation and Vibration. J. Basic Eng., vol. 86, no. 2, June 1964, pp. 328-336.
4. Sternlicht, B.; and Elwell, R. C.: Theoretical and Experimental Analysis of Hydrodynamic Gas-Lubricated Journal Bearings. Trans. ASME, vol. 80, no. 4, May 1958, pp. 865-878.
5. Sternlicht, B.: Gas-Lubricated Cylindrical Journal Bearings of the Finite Length-Static Loading. J. Appl. Mech., vol. 28, no. 4, Dec. 1961, pp. 535-543.
6. Anon.: Design of Gas Bearings. Vol I: Design Notes. Mechanical Technology, Inc., 1966.
7. Fleming, David P.; Cunningham, Robert E.; and Anderson, William J.: Stability Analysis for Unloaded Externally Pressurized Gas-Lubricated Bearings with Journal Rotation. NASA TN D-4934, 1968.

