

NASA TECHNICAL
MEMORANDUM

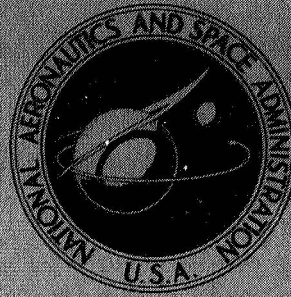

NASA TM X-1836

NASA TM X-1836

TWO-DIMENSIONAL CASCADE INVESTIGATION OF A TURBINE TANDEM BLADE DESIGN

by Stanley M. Nosek and John F. Kline

Lewis Research Center

Cleveland, Ohio

NATIONAL AERONAUTICS AND SPACE ADMINISTRATION • WASHINGTON, D. C. • JULY 1969

NASA TM X-1836

TWO-DIMENSIONAL CASCADE INVESTIGATION OF A
TURBINE TANDEM BLADE DESIGN

By Stanley M. Nosek and John F. Kline

Lewis Research Center
Cleveland, Ohio

NATIONAL AERONAUTICS AND SPACE ADMINISTRATION

For sale by the Clearinghouse for Federal Scientific and Technical Information
Springfield, Virginia 22151 - CFSTI price \$3.00

ABSTRACT

Static pressures were measured on the surfaces, and total pressures were surveyed downstream of the trailing edge. The objective was to determine the surface flow characteristics and the trailing-edge wake characteristics. Also overall performance in terms of kinetic energy loss was determined. Tests were with a six-bladed (five-passage) cascade in a tunnel open to atmosphere at the inlet. The inlet-total- to exit-static-pressure ratios were over a range from 1.2 to 1.5.

TWO-DIMENSIONAL CASCADE INVESTIGATION OF A TURBINE TANDEM BLADE DESIGN

by Stanley M. Nosek and John F. Kline

Lewis Research Center

SUMMARY

A tandem blade design was investigated in a two-dimensional cascade to determine (1) the loading and diffusion characteristics on the surfaces of the blade, and (2) the wake characteristics at the exit of the blade. Overall performance in terms of kinetic energy loss was determined from the wake traces. Static pressures were measured on the surfaces of the blade, and surveys of total pressure were made downstream of the trailing edge.

The study was made with a six-bladed cascade in a tunnel open to atmosphere at the inlet. Flow was varied by control of the exit pressure. The blades were tested at the design inlet flow angle over a range of inlet-total- to exit-static-pressure ratios from 1.2 to 1.5.

The tandem blade was tested first as originally designed and then with the leading edge of the aft airfoil cut back to change the shape of the channel between the forward and aft airfoils. The results obtained with the original design showed it to have a negative tangential force on the aft portion of the forward airfoil. Also the wake off the aft airfoil was thick so that losses were high. The loss in kinetic energy as a percentage of the ideal kinetic energy at the exit was as high as 11 percent. Changing the shape of the channel between the airfoils eliminated the negative force and distributed the load more equally between airfoils. The wake off the aft airfoil became thinner, smoother, and sharper. The loss in kinetic energy was reduced to a level of 5 percent.

INTRODUCTION

The requirements of advanced military and commercial aircraft emphasize the need for lightweight and compact engines. To meet this need in the turbine component, the obvious approaches are to reduce the number of stages, reduce the diameter, or reduce

the number of blades. But each of these approaches leads to higher loading on the blades and, hence, to the problem of how to increase this loading without sacrificing performance. The problem arises because an increase in loading on the blades is usually associated with an increase in diffusion (flow deceleration) on the suction surface. And there is a limit with conventional blades as to how much the diffusion can be tolerated before boundary-layer separation occurs and losses increase rapidly. So to increase the loading beyond that possible with conventional blades, it is necessary to find some new blade design or boundary-layer control concept to prevent or delay this separation. Such concepts may include vortex generators, tangential jets, jet flaps, or tandem blades.

Currently, the Lewis Research Center has experimental programs under contract (refs. 1 and 2) to explore the potential of these concepts. Reference 1 describes a program using an actual rotating turbine stage. Reference 2 describes a program using a three-dimensional cascade sector. The results of these programs to date are presented in references 3 to 6.

To explore these concepts more fundamentally and quickly, a two-dimensional cascade tunnel consisting of six blades (five passages) was built at Lewis. The first concept to be explored in this tunnel was the tandem blade. In essence, this concept cuts a conventional blade into two airfoils, a forward airfoil and an aft airfoil, so that the load is divided between them. The airfoils are arranged in tandem with the aft airfoil displaced tangentially so that its leading edge is out of the wake of the forward airfoil. In this manner, each airfoil starts without any accumulation of boundary-layer buildup and, being shorter, develops a thinner boundary layer on the surface. The combined diffusion, and hence loading, attainable with both airfoils should be greater than with a comparable conventional blade.

The first blade design chosen for the purpose of studying the flow characteristics of a tandem blade was the mean-section profile of the design for the rotor in reference 1. The results found are the subject of this report. Specifically, the blade was investigated to obtain (1) the loading and diffusion characteristics on the surfaces of the blade and (2) the wake characteristics at the exit. From the wake characteristics, a kinetic energy loss coefficient was determined as a measure of overall performance. To obtain the surface and wake flow characteristics, static pressures were measured on the surfaces of the blade, and total pressures were surveyed at the exit of the blade.

The blades were tested at their design inlet flow angle over a range of inlet-total-to-exit-static-pressure ratios from 1.2 to 1.5. These pressure ratios provided a range of ideal exit critical velocity ratios from 0.55 to 0.81.

SYMBOLS

C_x	axial chord
D_s	suction-surface diffusion parameter defined as the difference between peak velocity and trailing-edge velocity as a ratio of peak velocity
\bar{e}	kinetic energy loss coefficient
H_s	suction-surface boundary-layer form factor defined as ratio of displacement thickness to momentum thickness
p	pressure
S	pitch
u	distance in tangential or pitch direction
V	velocity
X	distance in axial direction
y	distance along span from end wall

Subscripts:

cr	condition at Mach 1
i	ideal
0	atmospheric condition, inlet to cascade tunnel
1	condition at entrance to blade passage
2	condition at exit from blade passage

Superscript:

'	total state
---	-------------

EQUIPMENT

The equipment used in this investigation consisted of the blades to be tested, a tunnel open to atmosphere at the inlet and connected to the laboratory exhaust system, and the instrumentation for taking the necessary measurements.

Blade Configuration

The tandem blades tested, with their pertinent design features, are shown in fig-

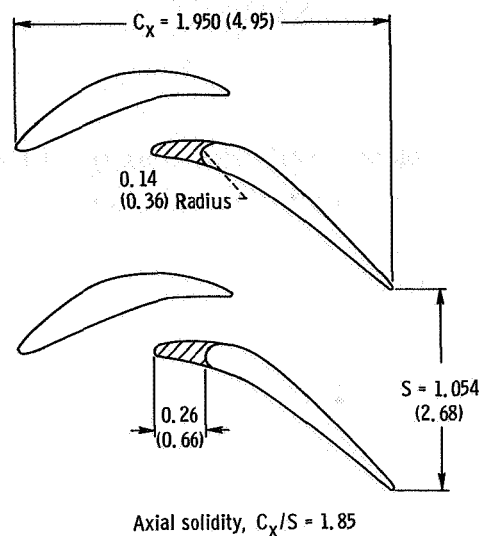

Figure 1. - Tandem blade profiles and channels.
Dimensions are in inches (cm).

ure 1. Two configurations of the blade were tested. They are referred to as the original tandem blade and the modified tandem blade. The airfoils for the original tandem blade were fabricated to the coordinates for the mean section from table VII of reference 1. The airfoils for the modified tandem blade were fabricated to the same coordinates but with the leading edge of the aft airfoil cut back axially (as shown in fig. 1). It was cut back 0.26 inch (0.66 cm) to a new leading edge of 0.14 inch (0.36 cm) diameter, tangent to the original pressure and suction surfaces. The purpose was to change the shape of the narrow channel formed between the two airfoils from a long channel of approximately constant width to a short, highly convergent channel.

The airfoils were mounted, in proper orientation and spacing, on end plates to make up a cascade of six blades, as shown in figure 2. The velocities and angles shown are the relative design values for the rotor at the mean section as given in figure 1 of reference 1. On a two-dimensional basis, with the angle shown, the exit velocity would be slightly higher. The same end plates were used for both the original and modified designs. As a result of the fabrication process in locating and cutting the slots in the end plates, the aft airfoil was found to have been displaced tangentially so that the narrow channel between the forward and aft airfoils was 0.058 inch (0.147 cm) greater than design. (The pitch of the blades was not affected.) The results presented in this report are for this larger spacing.

Cascade Tunnel

The cascade tunnel in which the blades were tested is shown in figure 3. Figure 3(a)

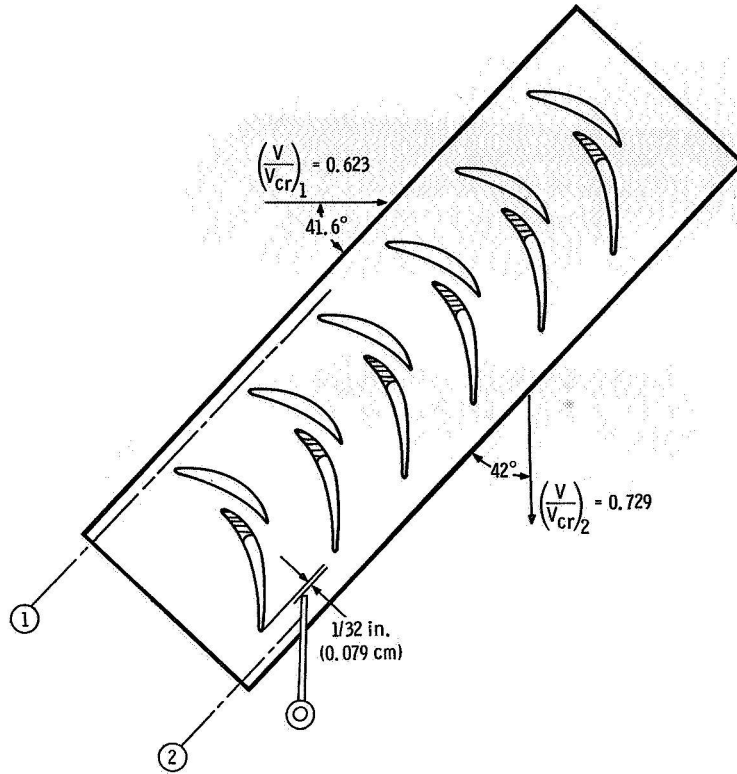

(a) Schematic diagram.

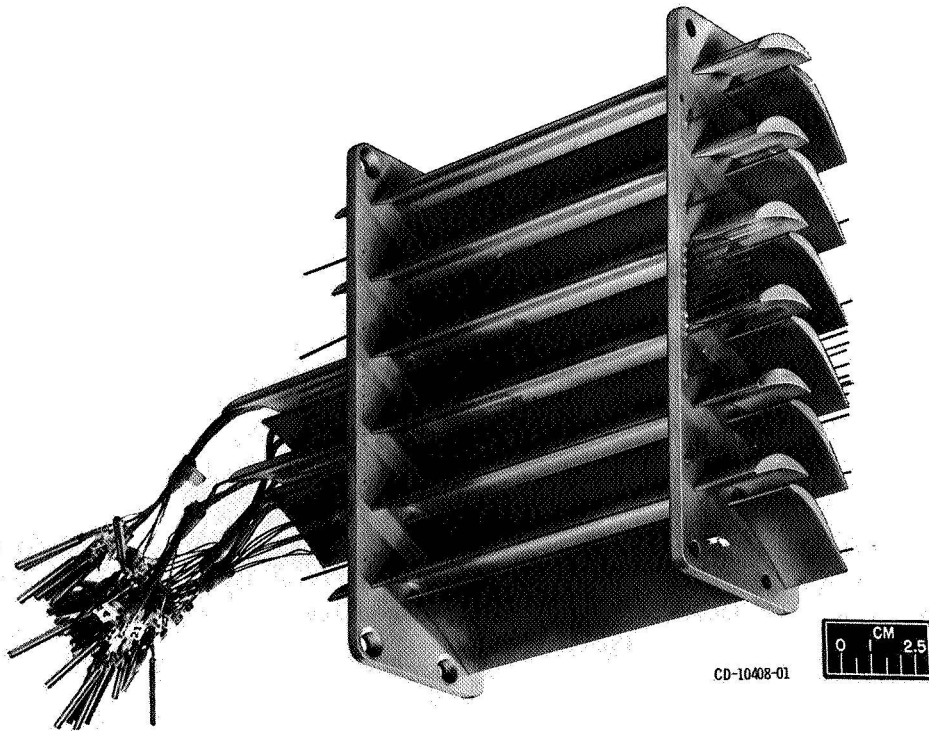

(b) Physical representation.

Figure 2. - Two-dimensional tandem blade cascade.

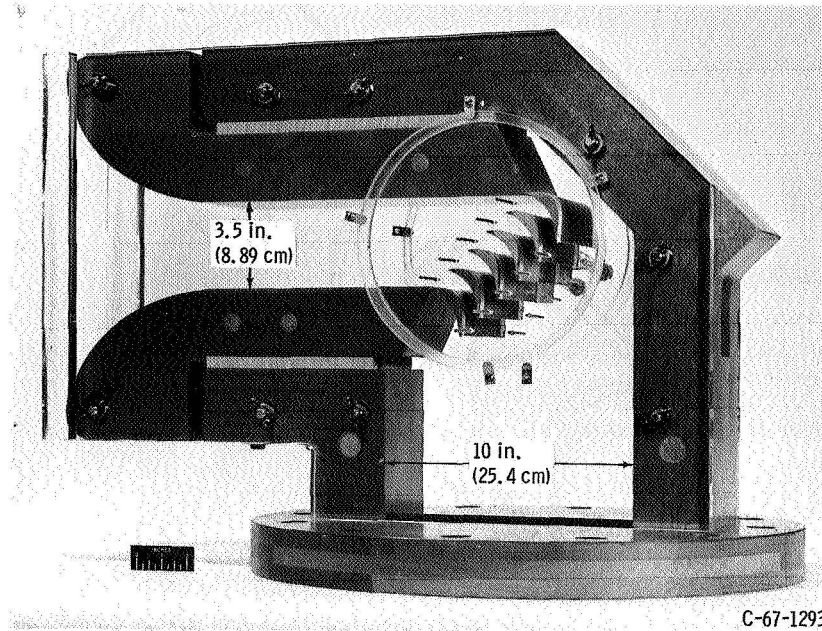

(a) Basic features.

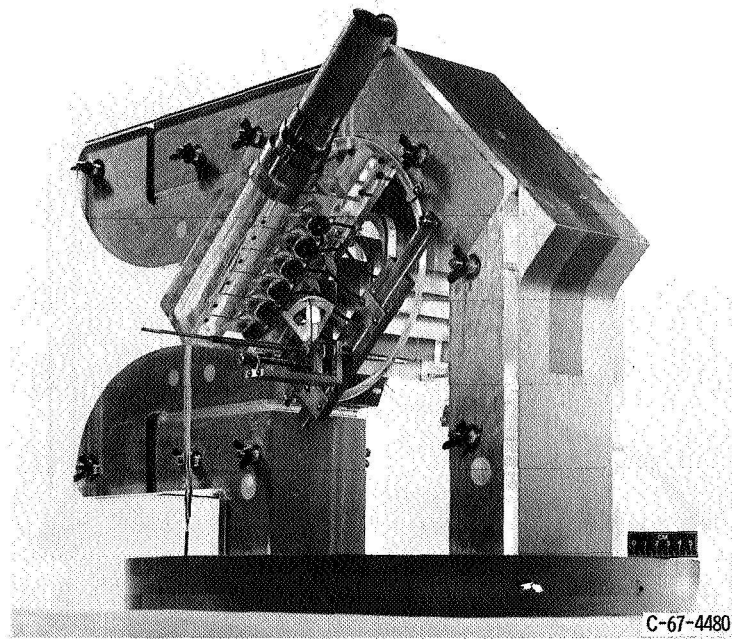

(b) Boundary-layer suction and probe mechanisms.
Figure 3. - Cascade tunnel.

shows the tunnel in its simplest form with a set of plain blades installed to emphasize its basic features. Figure 3(b) shows the design equipped with a boundary-layer suction device (on each side) and a mechanism for positioning and traversing the total-pressure probe. Not shown is the motor drive mechanism for traversing the probe.

The tunnel was fabricated from mahogany and 3/4-inch (1.91-cm) lucite. The blades were made from brass.

The distance between the lucite end walls is 5 inches (12.7 cm). Other pertinent dimensions are shown in figure 3(a). The aspect ratio, the distance between the end walls ratioed to the axial chord of the blades, is $2\frac{1}{2}$.

The tunnel was designed to accommodate a cascade of the six blades (5 passages) to be tested. The cascade was mounted on circular inserts to permit varying the angle of flow into the blades. In this investigation, the blades were tested at one angle only, the design angle. The inlet blocks can be translated and shimmed to adjust for blade rotation. The blades were tested with the blocks in line and in contact with the leading edge of the forward airfoil.

Boundary-layer suction was through a slot in the side walls. The boundary layer was collected by the manifold shown in figure 3(b), which was connected to the laboratory exhaust system. The slot extended across the inlet and ran parallel to the leading edges of the blades, 1/2 inch (1.27 cm) upstream of the leading edges. As determined with small probes near the wall behind the slot, the boundary-layer buildup was reduced to less than 0.030 inch (0.076 cm) before entering the blade passages.

Instrumentation

The cascade was instrumented to measure (1) inlet and exit static pressures, (2) blade surface static pressures, and (3) blade exit total-pressure profile. All static pressures were measured with mercury manometers. The manometers were arranged in banks and photographed during the test.

Inlet and exit static pressures. - A pressure tap was provided on the end walls at the inlet and exit of each blade passage. They were located on the midchannel streamline, 1/8 inch (0.318 cm) upstream of the leading edge and 1/8 inch (0.318 cm) downstream of the trailing edge. The size of the tap hole was 0.020 inch (0.051 cm). These taps can be seen in figure 2. Additional taps, which also can be seen in figure 2, were provided at the inlet and exit of the center blade passage to observe the static-pressure distribution across the passage from blade to blade.

Blade surface static pressures. - The static-pressure distribution around a blade at the mean section was determined by taps on the blade surfaces facing the center passage. The pressure surface of one blade and the suction surface of the other were instrumented. The tap holes were 0.020 inch (0.051 cm) or less and spaced about 1/8 inch (0.318 cm) apart in the midsection plane.

Blade exit total-pressure profile. - The total-pressure profile at the exit of the blades was determined by surveying across the two center blades with the probe shown installed in figure 3(b). The tip was tubing 0.020 inch (0.051 cm) in outside diameter with a 0.0025-inch (0.0064-cm) wall flattened to form an ellipse with a minor axis opening of 0.005 inch (0.0127 cm). The minor axis was perpendicular to the stem of the probe and therefore perpendicular to the trailing edge of the blade. The elliptical shape provided a large area for fast response with a small dimension for accurate definition of the pressure gradient across the wake. The pressure was measured with a differential pressure transducer of the strain-gage type and recorded on the y-axis of an X-Y recorder. The x-axis was connected to a potentiometer to record the travel of the probe.

TEST PROCEDURE

The procedure in this investigation was to test the blades over a range of inlet-total-to exit-static-pressure ratios from 1.2 to 1.5. The inlet total pressure was atmospheric. The exit static pressure was set by using one of the two end-wall taps 1/8 inch (0.318 cm) behind the trailing-edge plane and on the midchannel streamline of the center passage.

Before flow was started through the cascade, the boundary-layer suction was first turned on. Flow through the cascade was then established by remotely opening a valve to the laboratory exhaust system. A pressure ratio was set, and measurements were taken.

A total-pressure trace was recorded first. When the probe completed its traverse, a photograph was taken of the manometer panel. The probe was then returned to its starting position. The pressure ratio was increased and another set of data taken.

Complementary tests were made to ensure (1) that the 5-inch (12.7-cm) length of the blades was long enough to keep the midspan portion of the blade out of the influence of the end walls and (2) that the six blades were sufficient in number to establish a reasonably uniform flow condition across the middle passages. Total-pressure surveys at a number of locations between the end walls gave satisfactory evidence that the 5-inch (12.7-cm) span was long enough. The static taps on the end walls at the inlet and exit of each blade passage verified that the flow was substantially uniform into the middle passages. Therefore, all results presented are from data obtained only at the midspan of the two blades that define the center passage of the cascade.

RESULTS AND DISCUSSION

From the tests, the following results were obtained: (1) the loading and diffusion characteristics on the surfaces of the blade and (2) the wake characteristics at the exit of the blade. From the wake characteristics, a kinetic energy loss coefficient was calculated.

Also, a form factor was calculated for the portion of the wake off the aft airfoil suction surface.

The surface and exit characteristics at a pressure ratio that provided an inlet critical velocity ratio close to the design value in figure 1 are presented as typical. The kinetic energy loss coefficients and form factors at all the pressure ratios are included.

Blade Surface Loading and Diffusion Characteristics

Typical results of the loading and diffusion characteristics found on the surfaces of the original and modified blades are shown in figures 4 and 5. In figures 4(a) and 5(a), the static pressures measured on the surfaces are ratioed to the inlet total pressure and plot-

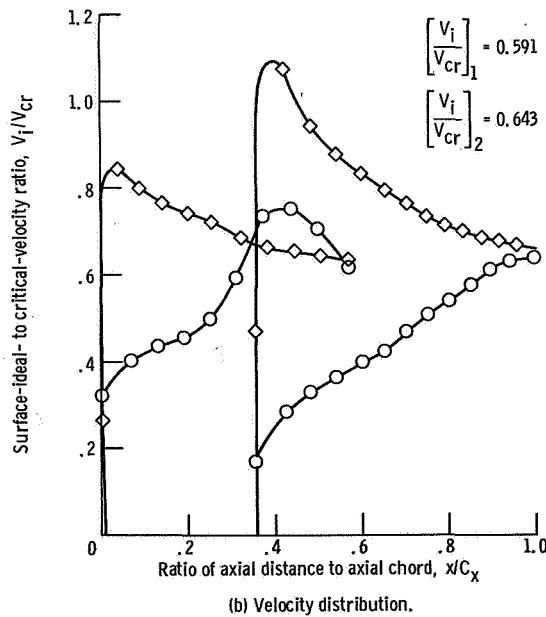
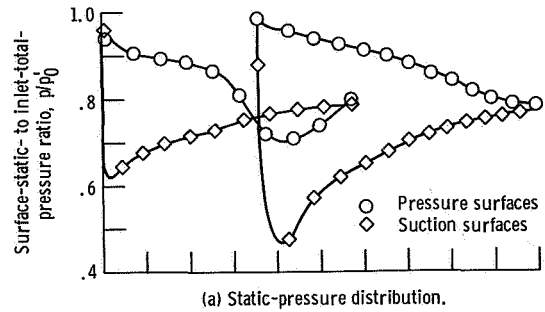
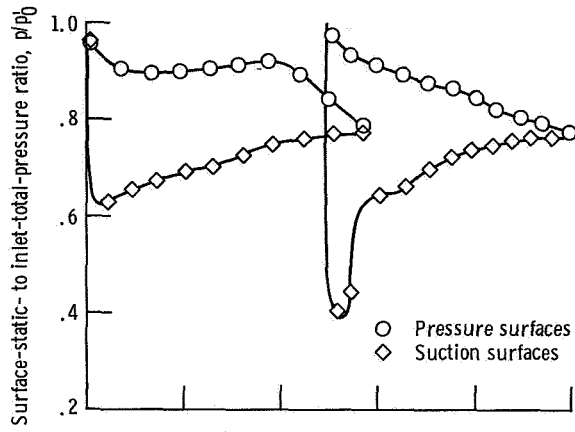
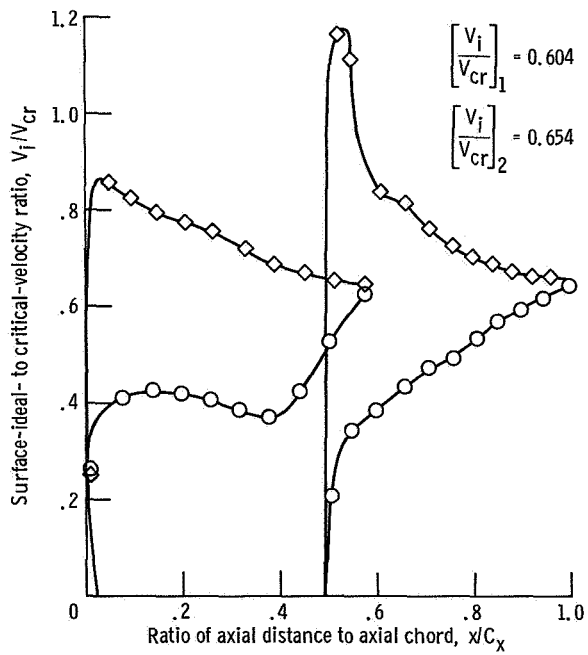

Figure 4. - Typical static-pressure and velocity distributions on surfaces of tandem blade for original design at inlet-total- to exit-static-pressure ratio p_0/p_2 of 1.28.



(a) Static-pressure distribution.



(b) Velocity distribution.

Figure 5. - Typical static-pressure and velocity distributions on surfaces of tandem blade for modified design at inlet-total- to exit-static-pressure ratio p_0/p_2 of 1.30.

ted against their location along the axial chord. In this manner, the plots indicate the tangential force distribution on the airfoils. The area between the curves is a measure of the total tangential force on the blade. In figures 4(b) and 5(b), the ideal critical velocity ratios corresponding to the pressure ratios are plotted to show the velocity and diffusion characteristics on the surfaces of the blades.

Figure 4 shows that the pressures and velocities cross over on the aft portion of the forward airfoil of the original design. This crossover creates a negative tangential force on this portion of the airfoil. The positive tangential force on the forward airfoil is reduced, and most of the force on the blade is therefore carried by the aft airfoil. The crossover is caused by the high velocities that occur in the narrow channel between the forward and aft airfoils. These high velocities were thought to be the result of the shape of the channel, which was approximately constant in width. These results prompted the aforementioned modification to the aft foil to form a highly convergent channel (see fig. 1).

The results of this change in the design are shown in the pressure and velocity curves of figures 5(a) and (b). The velocities on the pressure surface of the forward airfoil have been substantially reduced, and the crossover has been eliminated. Also the loading now has been more equally divided between the two airfoils.

Comparison of figures 4(b) and 5(b) indicate that, on the suction surface of the forward airfoil, the velocities remained virtually unchanged for both configurations. A peak velocity occurs near the leading edge and uniformly decelerates over the length of the airfoil. This diffusion expressed in terms of a diffusion factor D_g , defined as the difference between the peak velocity and the trailing-edge velocity as a fraction of the peak velocity, is 0.24. This is not a particularly high value. The design could probably be improved for further loading by an increase in the diffusion factor and a more efficient distribution of the velocity. A more efficient distribution would be to keep the velocity at the same level over a greater portion of the surface so that the area between the curves would approach a rectangular shape.

On the aft airfoil, the velocity distributions on both the pressure and suction surfaces are similar for the original and modified designs except that they are foreshortened in the modified design because of the cutback. Also the peak velocity is sharper for the modified airfoil from the more blunt leading edge. Because of the sharp peak velocity and the fact that some of the diffusion is within a narrow channel, it is difficult to derive a meaningful diffusion factor for the suction surface. The portion of the surface outside the channel is at about the same level as on the forward airfoil. Improvement in the design for further loading would be, first of all, to reduce the high peak velocity. Then, as suggested for the forward airfoil, the velocity distributions on both surfaces could be improved to approach a rectangular shape.

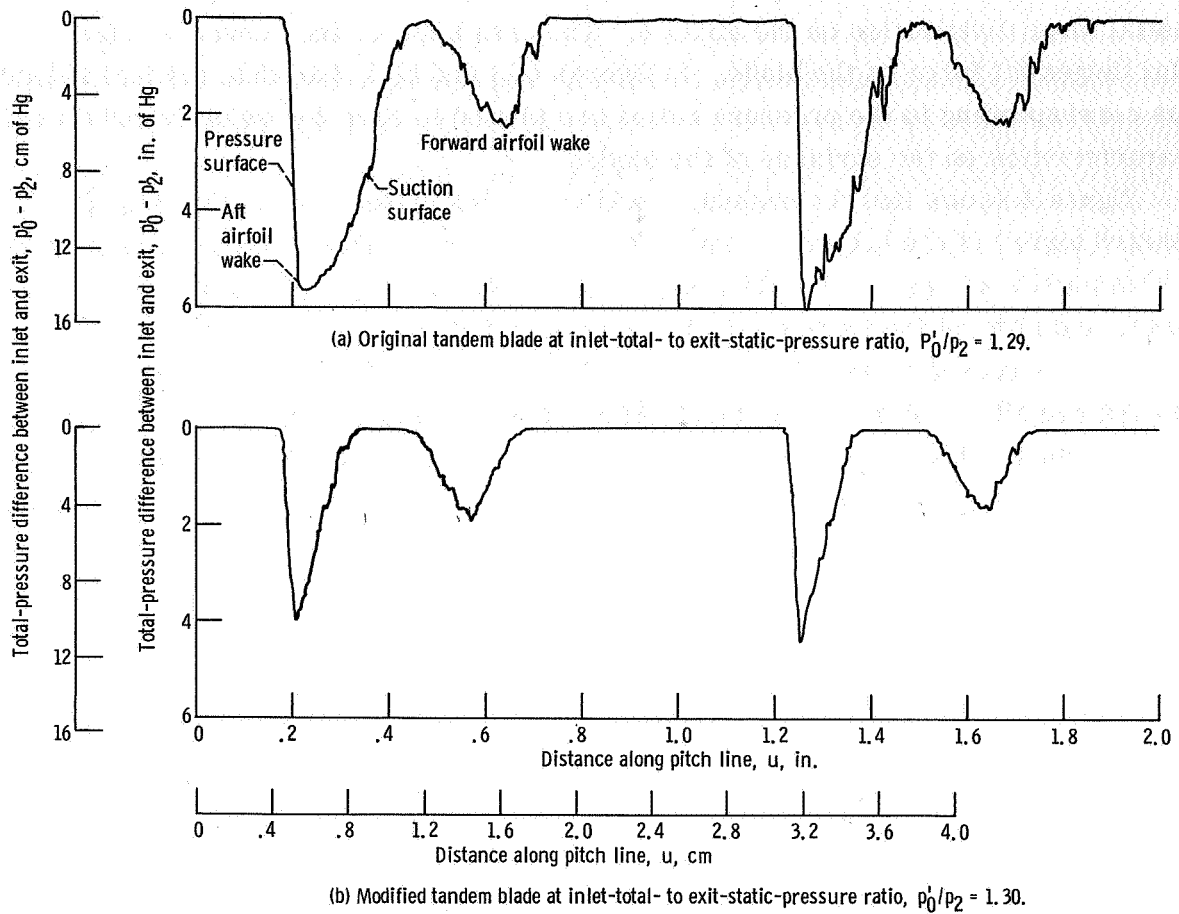

Figure 6. - Typical survey of exit-total-pressure drop at mean section of blade.

Blade Exit Wake Characteristics

Total-pressure profile. - Typical results of the total-pressure surveys taken at the exit of the blades at the mean section are shown in figures 6(a) and (b). The drop in total pressure from atmospheric is plotted against distance along the pitch of the blades. The surveys were made 1/32 inch (0.0794 cm) downstream of the trailing edge (see fig. 2).

In figure 6(a), for the original design, the significant feature to note is that the wake off the aft airfoil is thick and extends to the wake off the primary airfoil. Also to note is that most of the wake is made up of the boundary layer off the suction surface.

In figure 6(b), marked improvement results from modification of the aft airfoil. The boundary layer off the suction surface of the aft airfoil has been greatly reduced so that the wake is much thinner and sharper. Also the peak total-pressure loss has been reduced. Improvement of the velocity characteristics on the pressure surface on the forward airfoil within the channel has also improved the wake off the forward airfoil.

Wake form factor. - The wake traces in figure 6 show no positive evidence that there was separation from any of the blade surfaces. Likewise, the pressure distributions on the surfaces of the blades in figures 4(a) and 5(a) did not provide any evidence that there was separation. Therefore, the most that can be interpreted from the wake traces, with regard to separation, is the tendency to separate. For example, the boundary layer off the suction surface of the original airfoil in figure 6(a), by its size and thickness, is certainly closer to separation than that off the modified airfoil in figure 6(b).

As some measure of the separation tendency on this surface of the blade, a form factor was calculated for its portion of the wake. The form factor H_s is defined as the ratio of the displacement thickness to the momentum thickness. The greater the value, the greater is the tendency for the boundary layer to separate.

The method described in reference 7 was used to calculate the form factor. The results are shown in figure 7. Over the range of pressure ratios tested, the form factor for the original airfoil varied from about 2.0 at the low end to about 1.7 at the high end. For the modified airfoil, the form factor varied from about 1.4 at the low end to 1.6 at the high end. Numerically then, the margin for separation was improved by the modified airfoil.

Exactly how much this margin has been improved depends on the value of the form factor assumed for separation. Values of 1.8 and greater have been proposed, depending on whether the flow is in the incompressible or compressible regime. So, for the modified airfoil, the margin, particularly at the lower pressure ratios, has been significantly improved, even assuming the 1.8 value. The most that can be said for the original design is that, if it was not separating, it was probably very close to separating.

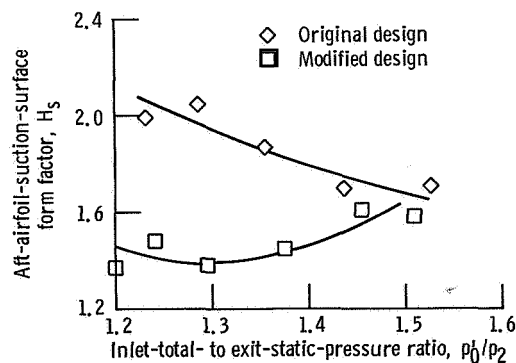

Figure 7. - Variation of aft-airfoil-suction-surface form factor with inlet-total-to-exit-static-pressure ratio.

Kinetic Energy Loss Coefficient

The kinetic energy loss coefficient, as defined in reference 8, is the ratio of the mass averaged kinetic energy loss of the stream to the ideal kinetic energy of the stream expanded over the same total- to static-pressure ratio. These were calculated for the total-pressure traces by the method presented in reference 7. The points used in the calculations were taken from smooth curves over the total-pressure traces (fig. 6). The points were taken at 0.02-inch (0.051-cm) increments along the pitch. The static pressure used in the calculations was the average of the two end-wall taps at the midchannel streamline of the center passage, 1/8 inch (0.318 cm) downstream of the trailing-edge plane. The results as a function of the pressure ratio across the blade are shown in figure 8. As was indicated directly by the traces of figure 6(b), the losses were substantially reduced by modification of the aft airfoil. The original design had losses as high as 11 percent, which decreased with increasing flow to about 8 percent. The modification reduced the losses by as much as a half, to about 5 percent, and maintained this level over the range of pressure ratios investigated.

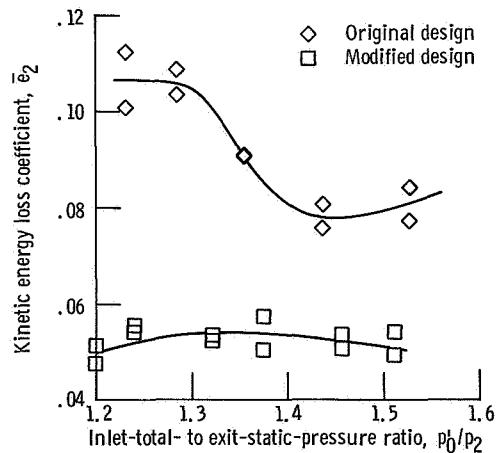

Figure 8. - Variation of kinetic energy loss coefficient with inlet-total- to exit-static-pressure ratio.

SUMMARY OF RESULTS

A tandem blade design was investigated in a six-bladed two-dimensional cascade. It was studied in two configurations, first as originally designed and then with a modification to the aft airfoil to change the shape of the channel between the two airfoils. The objectives were to determine (1) the loading and diffusion characteristics on the surfaces of the blades and (2) the wake characteristics at the exit of the blades. From the wake charac-

teristics, a kinetic energy loss coefficient was calculated for overall performance. Static pressures were measured on the surfaces of the blades, and surveys were made of the total pressure 1/32 inch (0.0794 cm) downstream of the trailing edge. The blades were tested over a range of inlet-total- to exit-static-pressure ratios from 1.2 to 1.5 in a tunnel open to atmosphere at the inlet. The following pertinent results were obtained:

1. The original design had a negative tangential force on the forward airfoil. This was eliminated by cutting back the leading edge of the aft airfoil.

2. The velocity distribution on the suction surface of the primary airfoil was not changed by modification of the aft airfoil. The peak velocity occurred near the leading edge, and the difference between the peak velocity and the trailing-edge velocity as a ratio of the peak velocity (diffusion factor) was 0.24.

3. The velocity distributions on both the pressure and suction surfaces of the aft airfoil were similar for the original and modified airfoils but foreshortened on the modified design because of the cutback. Diffusion on the portion of the suction surface outside the channel between the forward and aft airfoils was at about the same level as that on the forward airfoil.

4. The wake off the aft airfoil was substantially improved by the blade modification, being much thinner and sharper. The form factor, ratio of displacement thickness to momentum thickness, of the suction surface portion of the wake off the aft airfoil showed improvement in separation margin. The form factor ranged from 1.4 to 1.6, whereas for the original design it was as high as 2.

5. For the cutback blading, the kinetic energy loss was between 5 and 6 percent of the ideal kinetic energy at the exit over the range of inlet-total- to exit-static-pressure ratios tested. For the original design, it ranged between 11 percent at low flows and 8 percent at high flows.

Lewis Research Center,
National Aeronautics and Space Administration,
Cleveland, Ohio, April 16, 1969,
126-15-02-32-22.

REFERENCES

1. Lueders, H. G.: Experimental Investigation of Advanced Concepts to Increase Turbine Blade Loading. I. Analysis and Design. NASA CR-735, 1967.
2. Bettner, James L.: Experimental Investigation in an Annular Cascade Sector of Highly Loaded Turbine Stator Blading. I. Analysis and Design. NASA CR-1219, 1968.

3. Lueders, H. G.: Experimental Investigation of Advanced Concepts to Increase Turbine Blade Loading. II. Performance Evaluation of Plain Rotor Blade. NASA CR-1172, 1968.
4. Lueders, H. G.: Experimental Investigation of Advanced Concepts to Increase Turbine Blade Loading. III. Performance Evaluation of Tandem Rotor Blade. NASA CR-1254, 1968.
5. Bettner, James L.: Experimental Investigation in an Annular Cascade Sector of Highly Loaded Turbine Stator Blading. II. Performance of Plain Blade and Effect of Vortex Generators. NASA CR-1323, 1969.
6. Bettner, James L.: Experimental Investigation in an Annular Cascade Sector of Highly Loaded Turbine Stator Blading. III. Performance of Tandem Blade. NASA CR-1341, 1969.
7. Prust, Herman W., Jr.; Schum, Harold J.; and Behning, Frank P.: Cold-Air Investigation of a Turbine for High-Temperature Engine Application. II. Detailed Analytical and Experimental Investigation of Stator Performance. NASA TN D-4418, 1968.
8. Stewart, Warner L.: Analysis of Two-Dimensional Compressible-Flow Loss Characteristics Downstream of Turbomachine Blade Rows in Terms of Basic Boundary-Layer Characteristics. NACA TN 3515, 1955.

NATIONAL AERONAUTICS AND SPACE ADMINISTRATION
WASHINGTON, D. C. 20546
OFFICIAL BUSINESS

FIRST CLASS MAIL



POSTAGE AND FEES PAID
NATIONAL AERONAUTICS AND
SPACE ADMINISTRATION

POSTMASTER: If Undeliverable (Section 13
Postal Manual) Do Not Ret

"The aeronautical and space activities of the United States shall be conducted so as to contribute . . . to the expansion of human knowledge of phenomena in the atmosphere and space. The Administration shall provide for the widest practicable and appropriate dissemination of information concerning its activities and the results thereof."

— NATIONAL AERONAUTICS AND SPACE ACT OF 1958

NASA SCIENTIFIC AND TECHNICAL PUBLICATIONS

TECHNICAL REPORTS: Scientific and technical information considered important, complete, and a lasting contribution to existing knowledge.

TECHNICAL NOTES: Information less broad in scope but nevertheless of importance as a contribution to existing knowledge.

TECHNICAL MEMORANDUMS: Information receiving limited distribution because of preliminary data, security classification, or other reasons.

CONTRACTOR REPORTS: Scientific and technical information generated under a NASA contract or grant and considered an important contribution to existing knowledge.

TECHNICAL TRANSLATIONS: Information published in a foreign language considered to merit NASA distribution in English.

SPECIAL PUBLICATIONS: Information derived from or of value to NASA activities. Publications include conference proceedings, monographs, data compilations, handbooks, sourcebooks, and special bibliographies.

TECHNOLOGY UTILIZATION PUBLICATIONS: Information on technology used by NASA that may be of particular interest in commercial and other non-aerospace applications. Publications include Tech Briefs, Technology Utilization Reports and Notes, and Technology Surveys.

Details on the availability of these publications may be obtained from:

SCIENTIFIC AND TECHNICAL INFORMATION DIVISION
NATIONAL AERONAUTICS AND SPACE ADMINISTRATION
Washington, D.C. 20546