

**NASA CONTRACTOR
REPORT**

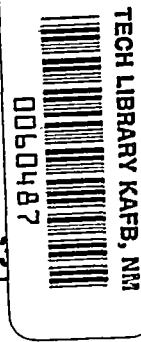

NASA CR-13

C.1



NASA CR-1384

LOAN COPY: RETURN TO
AFWL (WLIL-2)
KIRTLAND AFB, N MEX

**AN INVESTIGATION OF
THE BASIC PROPERTIES OF
IRRADIATED POLYETHYLENE
MEMORY MATERIALS**

by Preston Keusch, Donald Greer, and John Rozembersky

Prepared by
RAI RESEARCH CORPORATION
Long Island City, N. Y.
for Langley Research Center





AN INVESTIGATION OF THE BASIC PROPERTIES OF
IRRADIATED POLYETHYLENE MEMORY MATERIALS

By Preston Keusch, Donald Greer, and John Rozembersky

Distribution of this report is provided in the interest of
information exchange. Responsibility for the contents
resides in the author or organization that prepared it.

Issued by Originator as Report No. RAI 397

Prepared under Contract No. NAS 1-7335 by
RAI RESEARCH CORPORATION
Long Island City, N.Y.

for Langley Research Center

NATIONAL AERONAUTICS AND SPACE ADMINISTRATION

For sale by the Clearinghouse for Federal Scientific and Technical Information
Springfield, Virginia 22151 - CFSTI price \$3.00



FOREWORD

The work described in this report was performed during the period 31 May 1967 to 31 July 1968 under Contract No. NAS1-7335 with the National Aeronautics and Space Administration.

The authors wish to acknowledge the valuable guidance of Dr. David E. Bowker, Technical Officer, during the course of the contract.

We also wish to acknowledge the helpful discussions with Mr. Vincent F. D'Agostino, Vice President-Research, R A I Research Corporation.

The assistance of Mr. John A. Raffo in the performance and set-up of many of our experiments is gratefully acknowledged.

TABLE OF CONTENTS

	<u>Page</u>
ABSTRACT.....	xi
1.0 INTRODUCTION.....	1
1.1 History.....	2
2.0 THEORY.....	4
2.1 The Memory Force.....	5
2.2 The Crosslinking Mechanism.....	10
2.2.1 Effect of Ionizing Radiation on Polymers.....	10
2.2.2 The Factors Affecting Crosslinking... Dose.....	12
2.2.2.1	13
2.2.2.2 Molecular Weight.....	14
2.2.2.3 Molecular Weight Distribution.....	14
2.2.2.4 Crystallinity and Temperature.....	17
2.2.2.5 The Degree of Branching.....	19
2.2.2.6 The Effect of an Oxygen Atmosphere... Theoretical Determination of the Degree of Crosslinking.....	20
2.3 Dimensional Stability - Annealing... Shrinkage Mechanism-Oriented Crystallization and Contractility....	23
3.0 EXPERIMENTAL PROGRAM.....	27
3.1 Initial Qualifications Tests.....	29
3.2 Memory-Crosslinking Properties vs. the Basic Properties of the Four Materials.....	31
3.2.1 The Production of the Experimental, Crosslinked Polyethylene Films.....	31
3.2.1.1 The Production of the Polyethylene Films.....	31
3.2.1.2 The Irradiation of the Polyethylene Films.....	32
3.2.2 Gel vs. Dose Study.....	34
3.2.3 Modulus of Elasticity Above the Crystalline Melt Point vs. Dose.....	36
3.2.4 Memory vs. Dose Study.....	39
3.2.5 Shrinkage vs. Orientation Study.....	46
3.2.6 Discussion of Experimental Results... Gels.....	48
3.2.6.1	48
3.2.6.2 Modulus of Elasticity.....	53
3.2.6.3 Memory.....	53
3.2.6.4 Dimensional Stability.....	54

TABLE OF CONTENTS (Continued)

	<u>Page</u>
4.0	DETAILED EVALUATION OF FINAL MATERIAL.....56
4.1	Mechanical Properties of Gulf 5555 Polyethylene Film.....56
4.1.1	Stress-Strain Curve for Uncrosslinked Material at Ambient Temperature.....56
4.1.2	Stress-Strain Curve for Crosslinked Material at 140°C.58
4.1.3	Modulus-Thickness Evaluation at 140°C.58
4.1.4	Modulus-Temperature Study.....62
4.2	Shrinkage Properties and Equilibrium States of 1.5 Mil Gulf 5555 Polyethylene Film.....63
4.2.1	Equilibrium Lengths.....63
4.2.2	Crystallinity.....66
4.3	Environmental Tests.....71
5.0	BUCKLING PRESSURE THICKNESS STUDY.....74
6.0	CONCLUSIONS AND RECOMMENDATIONS.....79
6.1	Crosslinking Properties.....79
6.2	Mechanical Properties.....80
6.3	Memory.....80
6.4	Processing.....80
6.5	Uses.....81
6.6	Future Work.....83
7.0	REFERENCES.....87
8.0	LIST OF SYMBOLS.....90
APPENDIX I	GEL PERMEATION CHROMATOGRAPHY TO DETERMINE MOLECULAR WEIGHT DISTRIBUTIONS.....93
APPENDIX II	THE DETERMINATION OF THE PERCENT CRYSTALLINITY OF POLYETHYLENE FILM BY INFRARED SPECTRA MEASUREMENTS.....102
APPENDIX III	INFRARED SPECTRA.....104

LIST OF TABLES

<u>Table</u>	<u>Page</u>
1	Basic Properties of Initial Polyethylene Materials Investigated.....30
2	Processing Properties of the Films Used in the Program.....33
3	Memory vs. Dose with Thickness as a Parameter for the Materials under Study.....43
4	Dimensional Stability of Films of Different Orientation upon Completion of a Memory Cycle.....47
5	Summary of Molecular Weights and Distributions for Various Test Methods.....52
6	Modulus of Elasticity vs. Temperature for Gulf 5555 in Extrusion and Transverse Directions.....64
7	Lengths Relative to Unheated State of 1.5 Mil Gulf 5555 Film in Extrusion Direction in Hot and Cold States vs. Dose....67
8	Changes of Properties with Time of Annealed (State III) Crosslinked Gulf 5555, 1.5 Mil Polyethylene Film.....70

LIST OF ILLUSTRATIONS

<u>Figure</u>		<u>Page</u>
1	SCHEMATIC DIAGRAM OF MEMORY CONCEPT FOR DEPLOYMENT.....	6
2	DECREASE IN SOLUBLE FRACTION OF CROSSLINKED POLYMER WHEN δ EXCEEDS 1.....	16
3	SOME CALCULATED SOL- δ CURVES.....	16
4	FRACTION CRYSTALLINITY OF POLYETHYLENE VS. TEMPERATURE.....	18
5	CROSSLINKING EFFICIENCY IN CRYSTALLINE AND AMORPHOUS REGIONS OF POLYETHYLENE VS. TEMPERATURE.....	18
6	EXPERIMENTAL DOSE-DEPTH RELATIONSHIP FOR 1.5 MeV ELECTRONS PASSING THROUGH POLYETHYLENE.....	35
7	GEL FRACTIONS VS. DOSE FOR CROSSLINKED POLYETHYLENES UNDER STUDY.....	37
8	$s+s^{\frac{1}{2}}$ VS. r_{gel}/r FOR POLYETHYLENES UNDER STUDY.....	38
9	MODULUS OF ELASTICITY AT 140°C. VS. DOSE FOR THIN GAUGE MATERIALS UNDER STUDY.....	40
10	WRINKLE RECOVERY, "MEMORY", TESTING APPARATUS-SCHEMATIC.....	42
11	WRINKLE RECOVERY, "MEMORY," TESTING APPARATUS-PHOTOGRAPH.....	42
12	THE MOLECULAR WEIGHT BETWEEN CROSSLINKS M_c VS. DOSE FOR THE MATERIALS UNDER STUDY..	50
13	LOG MOLECULAR WEIGHT DISTRIBUTIONS OF THE POLYETHYLENES UNDER STUDY.....	51
14	STRESS-STRAIN CURVES FOR UNCROSSLINKED GULF 5555 1.5 MIL POLYETHYLENE FILM AT AMBIENT TEMPERATURE.....	57
15	STRESS-STRAIN CURVES FOR CROSSLINKED GULF 5555 1.5 MIL POLYETHYLENE FILM AT 140°C.	59

LIST OF ILLUSTRATIONS (Continued)

<u>Figure</u>		<u>Page</u>
16	MODULUS OF ELASTICITY AT 140°C. OF GULF 5555 FILM VS. DOSE WITH THICKNESS AS A PARAMETER.....	60
17	MODULUS OF ELASTICITY VS. TEMPERATURE FOR 1.5 MIL GULF 5555 POLYETHYLENE FILM...	65
18	THEORETICAL SPHERE SKIN THICKNESS REQUIRED TO WITHSTAND SOLAR PRESSURE VS. RADIUS WITH MODULUS AS A PARAMETER.....	76
19	THEORETICAL SPHERE SKIN THICKNESS TO WITHSTAND SOLAR PRESSURE VS. TEMPERATURE WITH RADIUS AS A PARAMETER.....	77
20	SIMPLIFIED SCHEMATIC DIAGRAM OF GPC APPARATUS.....	94
21	GPC CALIBRATION CURVES.....	97
22	MOLECULAR WEIGHT CHROMATOGRAM BY GPC ON GULF 5555 FILM.....	98
23	MOLECULAR WEIGHT CHROMATOGRAM BY GPC ON PHILLIPS 3328 FILM.....	99
24	MOLECULAR WEIGHT CHROMATOGRAM BY GPC ON DUPONT SUPER C FILM.....	100
25	MOLECULAR WEIGHT CHROMATOGRAM BY GPC ON PHILLIPS 6003 FILM.....	101
26	INFRARED SPECTRA OF POLYSTYRENE STANDARD.	105
27	INFRARED SPECTRA OF POLYETHYLENES USED IN MAIN PART OF STUDY - GULF 5555 AND DUPONT SUPER C.....	106
28	INFRARED SPECTRA OF POLYETHYLENES USED IN MAIN PART OF STUDY - PHILLIPS 3328 AND PHILLIPS 6003.....	107
29	INFRARED SPECTRA-TIME STUDY OF ANNEALED STATE III, CROSSLINKED, GULF 5555 1.5 MIL POLYETHYLENE FILM - 0.14 HR. AND 0.31 HR.	108

LIST OF ILLUSTRATIONS (Continued)

<u>Figure</u>		<u>Page</u>
30	INFRARED SPECTRA-TIME STUDY OF ANNEALED STATE III, CROSSLINKED, GULF 5555 1.5 MIL POLYETHYLENE FILM - 0.60 HR. AND 0.86 HR..	109
31	INFRARED SPECTRA-TIME STUDY OF ANNEALED STATE III, CROSSLINKED, GULF 5555 1.5 MIL POLYETHYLENE FILM - 1.87 HR. AND 24.62 HR.	110
32	INFRARED SPECTRA-TIME STUDY OF ANNEALED STATE III, CROSSLINKED, GULF 5555 1.5 MIL POLYETHYLENE FILM - 101 HR. AND 389 HR. .	111
33	INFRARED SPECTRA-TIME STUDY OF ANNEALED STATE III, CROSSLINKED GULF 5555 1.5 MIL POLYETHYLENE FILM - 700 HR.	112

ABSTRACT

This report describes the work done and conclusions arrived at in an investigation of the basic properties of irradiated polyethylene memory materials. The properties affecting crosslinking, the main factor which determines the memory in polyethylene, were investigated using different commercial polyethylene materials. These properties included: Molecular Weight, Molecular Weight Distribution, and the Degree of Branching.

It was found that the molecular weight distribution was the main factor that influences the crosslinking efficiency. In addition, the conditions at which the crosslinking occurs were investigated. These conditions are temperature, oxygen environment, and radiation dose. It was found that at irradiations conducted around 25°C., temperature is not an important factor but that the presence of oxygen does affect the crosslinking of thin films.

Memory (restoration) studies were also performed using the different commercial polyethylene materials to see if they completely restored after being deformed. It was found that the material with the best crosslinking properties had the best memory characteristics. Finding the properties for a superior memory material also involved determining the causes and control of shrinkage. It was found that processing induced orientation caused the shrinkage. The control of the problem entailed producing

stress-free materials either by annealing oriented material or by producing unoriented material. In addition, for the first time a crosslinked thin film (1.0 mil) material was demonstrated to restore 100% in a 1-g environment.

The mechanical properties of the superior memory material tested, Gulf "Poly-Eth" 5555 (Gulf 5555) film, were determined in detail. These properties included tensile tests and modulus of elasticity determinations at temperatures between -70°C . and 175°C . With the mechanical properties known, skin-thickness-size relationships were established for spheres required to withstand buckling pressures. It was found that from a weight standpoint, spheres using the memory material are competitive with Echo I.

These considerations now permit memory material to be used to construct and deploy such objects as air density spheres, environmental detection spheres, reflectors and structural items such as I-beams and booms.

In anticipation of using this memory material to construct and deploy objects in space it is recommended that a thermal control study and an annealing process scale-up be undertaken. Culminating these studies, the actual 0-g deployment test on spheres should be initiated.

AN INVESTIGATION OF THE BASIC PROPERTIES
OF IRRADIATED POLYETHYLENE MEMORY MATERIALS

By Preston Keusch
Donald Greer
John Rozembersky

R A I Research Corporation

1.0 INTRODUCTION

The purpose of this contract, NAS1-7335, is to establish trends in the mechanical and molecular properties of irradiated polyethylene so that its suitability for applications in space, such as for deployment of objects as passive communications satellites, air density spheres, unfurlable sensing devices and other structures, can be evaluated. Most of the mechanical properties investigated were concerned with the memory or "deployment" characteristics of the material, while most of the molecular properties were concerned with the crosslinking characteristics of the polyethylene when irradiated with high energy electrons. The molecular properties affecting the crosslinking characteristics were determined since crosslinking is the factor that gives the polyethylene its elastomeric properties or "memory" for self-deployment.

The approach undertaken was to initially investigate in house a large number of commercially available polyethylene films and resins and, based on their molecular and mechanical properties, and their availability, to select from this collection a representative number of them to be used in further studies of the effect of molecular properties on crosslinking and memory. From the four

representative polyethylene films, the one with the best properties for use as a memory material was then thoroughly investigated. With the guidelines known from theory, essentially two basic properties were studied with the final four materials. These properties were molecular weight distribution, and density. The following has been found: The theoretical molecular and crosslinking properties suitable to enhance the memory effect have been established. Basically, narrow molecular weight distribution, low density polyethylene resins crosslink best. The mechanical properties of the memory materials have been investigated. This includes the basic memory force as characterized by the modulus of elasticity above the crystalline melt point of the polymer as well as a modulus-temperature study in the range of -70°C . to 175°C . The effects of processing on the memory effect have also been established. In addition, the memory phenomenon has been demonstrated on thin, crosslinked polyethylene film. It has been successfully shown that the memory force is operative on thin films in a 1-g field.

1.1 History

The memory effect induced in polyethylene by irradiation of plastic with either beta or gamma radiation was first noted by Charlesby^{1*} in his book, "Atomic Radiation and Polymers" wherein he describes the memory phenomenon as "an interesting and often amusing property

*Raised number indicates references listed on pp. 87, 88 and 89.

of lightly irradiated polyethylene". He notes further that the memory phenomenon "relies on the fact that on irradiation a crosslinked network is formed with a definite equilibrium state. When other constraints such as crystallinity or external stresses are removed, the polymer will return to the same molecular arrangement it had during radiation". The memory effect will be discussed more fully in Section 2.1 of this report.

The application of this plastic memory effect to the development of a space structure was first proposed by R A I in 1961. This resulted in a preliminary study of the phenomenon under contract NASr-78 to the National Aeronautics and Space Administration. The scope of work under this contract, although empirical in nature, was directed toward an investigation of the mechanism of the memory phenomenon to permit adaptation of the process to development of erectable space structures. To this end the feasibility of the memory effect was studied and demonstrated.

Following this, under contract NAS5-3923, a design study for development of a 425-ft. diameter passive communications satellite for radio-frequency reflection was undertaken. The design weight of the satellite was 897 lbs. This satellite was to be deployed by use of the plastic memory effect. Within this study it was found that thin (low weight) polyethylene films could withstand solar pressures, and the thin polyethylene films to be used in constructing the sphere could be metallized and bonded.

2.0 THEORY

Prior to discussion of the theory on the experimental results obtained under this contract, a description of the workings of the plastic memory phenomenon and the processing steps leading to the production of a memory material will be given. The development of the memory force in plastics is accomplished as follows:

1. A thermoplastic polymer (such as polyethylene) having a crystalline structure is irradiated in a predetermined configuration. The irradiation produces crosslinks in the polymer. The irradiation is conducted using either beta or gamma radiation.

2. The irradiated object is then heated above its crystalline melting point (T_m) and in this state can be folded and packaged. (Of course the object may be packaged in a cool state, also.)

3. The folded or packaged object is allowed to cool permitting the crystal structure to develop. This configuration is then retained indefinitely by virtue of its "frozen" crystalline structure.

4. Upon reheating the object above its crystalline melting point, it will return to the configuration it had during irradiation.

Investigations conducted under this contract have shown that the above has to be qualified for oriented materials stressed by processing. If the material is produced (such as by extrusion) with orientation, the material

when heated above its T_m will tend to shrink, thereby not returning to its original shape. Consequently, the shrinkage must be designed for and/or eliminated before a memory cycle is initiated. This is accomplished by a heat treating or annealing step after the irradiation. The configuration of the material after heat treatment is considered in the desired equilibrium state. The whole stepwise plan is shown in Figure 1.

The theory, which will follow, is divided into three parts. The first part discusses the nature of the elastic forces and the factors that determine them. The second part discusses crosslinking, the main factor that governs the memory forces. In the section on crosslinking the basic polymeric properties affecting crosslinking are discussed. The third part discusses the problems of dimensional stability and the mechanism of "oriented crystallinity and contractility in the absence of tension".

2.1 The Memory Force

When a crosslinked polymer is taken above its crystalline melting point (T_m), its polymeric molecules are in an essentially random coiled conformation, randomly tied together by the crosslinks. These crosslinks tend to keep the molecules in relatively the same positions to each other whether above or below the T_m . The random state the matrix of molecules is in, above the T_m , can be considered an equilibrium state and consequently any distortion from this state, as by a deformation, will tend to restore to

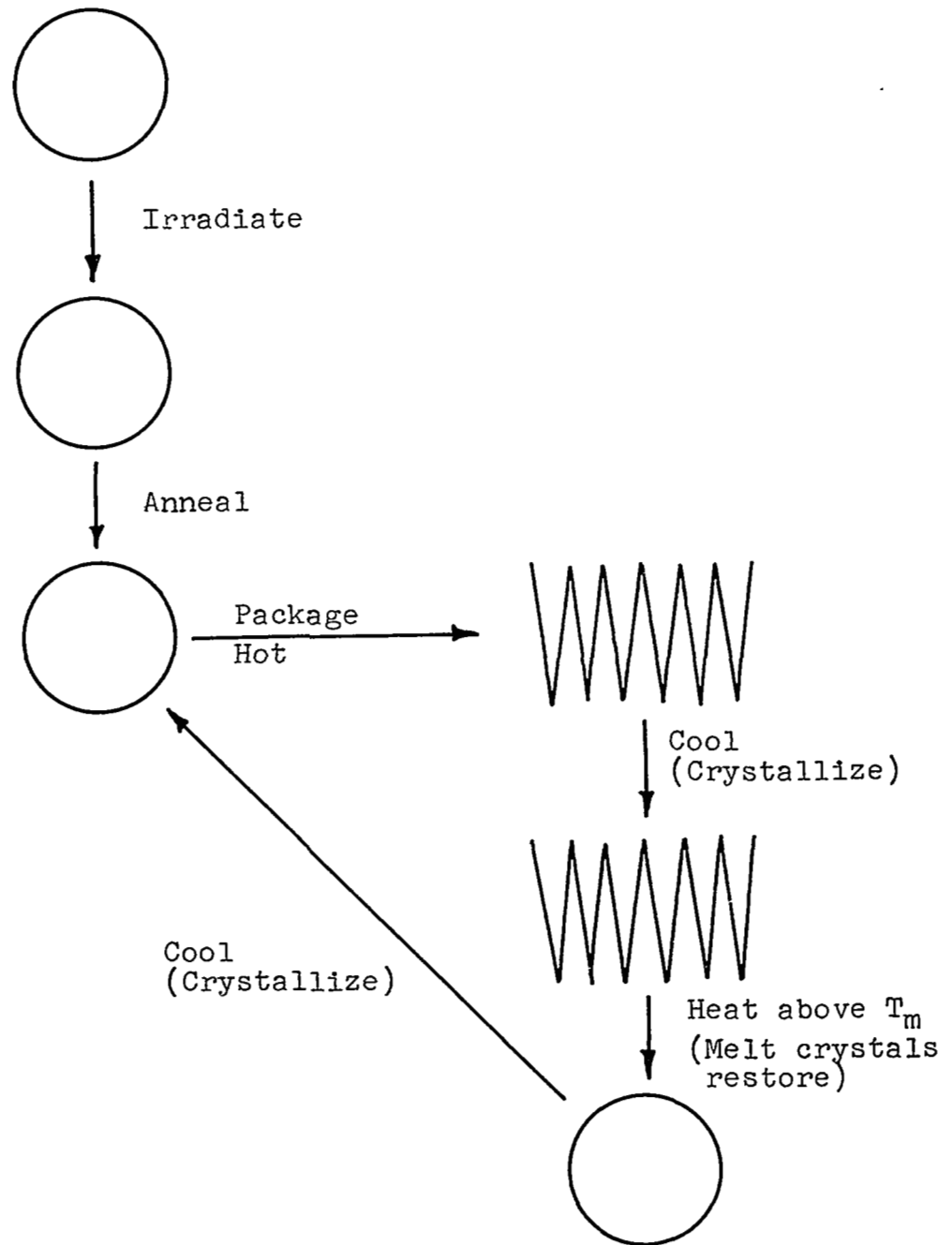

Figure 1 SCHEMATIC DIAGRAM OF MEMORY CONCEPT FOR DEPLOYMENT

its original conformation-which will be essentially its conformation when crosslinked. This restoration of the matrix of molecules to its equilibrium state, when observed macroscopically on a crosslinked polymer material, is known as the "memory effect".

In non-crosslinked polymers, once the T_m is exceeded, the polymer exhibits permanent flow properties and the memory phenomenon is not observed. Irradiation of certain thermoplastics, however, causes the development of crosslinks in the thermoplastic, thereby changing the linear structure to a three-dimensional network. Radiation, in effect, vulcanizes the plastic and makes it an elastomer. The elastomeric properties, however, are not observed at temperatures below the T_m because the crystalline forces are much greater than the memory forces. When the crystalline force is eliminated by exceeding the crystalline melting point, the memory phenomenon is observed.

From the theory of rubber elasticity,^{2,3} it is possible to calculate the force in distorting a molecule from its equilibrium conformation. With this force known, the energy stored in a unit volume made up of a number of these distorted molecules may be evaluated. From this the modulus of rubber elasticity is then found to be

$$E = 3vk\langle\alpha\rangle^2gT \quad (1)$$

where k = Boltzmann constant
 T = absolute temperature (above T_m)
 v = number of chains per unit volume

$$= \frac{\rho N'}{M_c} \left(1 - \frac{2M_c}{M_n} \right)$$

ρ = density
 N = Avagadro's Number
 M_c = Molecular Weight between crosslinks
 M_n = Number Average Molecular Weight of chain
 $\langle\alpha\rangle$ = the linear dialation factor = average chain length in the oriented state/ average chain length in the unoriented state
 g = the entanglement factor

In this equation, $\langle\alpha\rangle$, the linear dialation factor, reflects the effect of processing on the modulus. If, when crosslinked the material were oriented, $\langle\alpha\rangle$ will be greater than 1, and depending upon the degree of orientation $\langle\alpha\rangle$ may vary-getting larger with orientation. Thus, $\langle\alpha\rangle$ accounts for initial equilibrium states which deviate from the entirely random one. Consequently, if the processing produces materials of different molecular alignments and orientations their moduli will be different even if they are made from the same resin and crosslinked under identical conditions. In addition, g , is a correction factor taking into account the fact that molecular entanglements also can act as crosslinks. This factor, g , is mainly dependent on the high molecular weight molecules which are the ones that most readily entangle.

Equation (1) may not entirely comply to crosslinked

polyethylene. For one, the base polyethylene is composed of branched molecules-not the ideal random chains. Additionally, the base polyethylene is not composed of molecules of a single molecular weight but of a distribution of molecular weights-some of which do not crosslink. Nonetheless, equation (1) may be used as a guide to the experimental study of polyethylene memory material. Of paramount importance is the fact that the memory forces can be characterized by the modulus of elasticity above the T_m - and this modulus can be thought of as a "spring constant" for the material. Equation (1) additionally predicts the effect of density (ρ), orientation ($\langle \alpha \rangle$), and molecular weight (M_n). For all three, the modulus should increase as the property increases in value. Furthermore, equation (1) predicts the effect of crosslinking on E. It is seen, as more crosslinkages are introduced, that E should increase as $\frac{1}{M_c} \left(1 - \frac{2M_c}{M_n} \right)$, since M_c the molecular weight between crosslinks will get smaller as the density of crosslinks increases. Because the crosslinkages are necessary for implementation of the memory effect as well as the determining factor of the memory force, it is important to know what factors in the polyethylene resin itself determine the efficiency and degree of crosslinking when it is irradiated with high energy electrons or γ -rays. The effect of the molecular properties of polyethylene on the crosslinking efficiency and degree of crosslinking will be discussed in the next section.

2.2 The Crosslinking Mechanism

2.2.1 Effect of Ionizing Radiation on Polymers

Ionizing radiations, such as β particles (electrons) or gamma rays, generally interact with polymeric materials to cause either crosslinking or degradation. (Other reactions, such as the production or removal of unsaturation and the formation of gases, may also occur.) Extensive discussions on the effects of radiation on polymers can be found in the texts by Charlesby,¹ Chapiro,⁴ and Bovey⁵. The overall effect of crosslinking is that the molecular weight of the polymer increases until ultimately a three-dimensional insoluble network is formed.

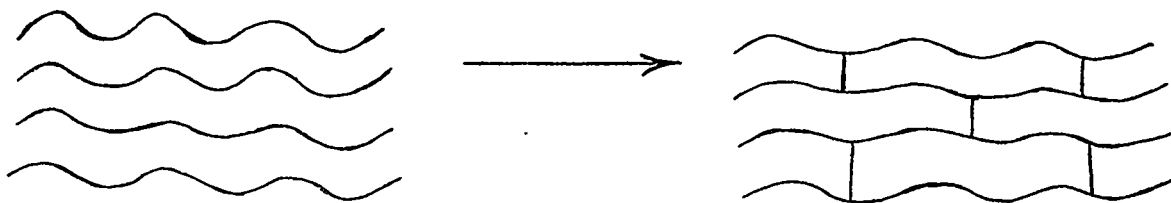

Crosslinked polymers no longer melt at the normal melting temperature, and have increased tensile strength and decreased elongation.

On the other hand, radiation degradation results in the polymer suffering random chain scissions.

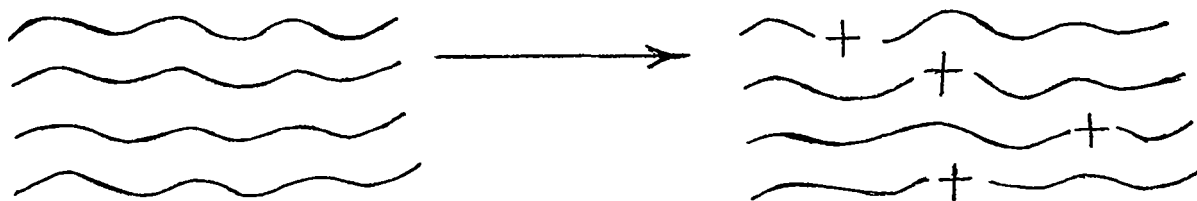

Thus, the molecular weight steadily decreases with radiation dose and in extreme cases a low molecular weight liquid may result. Degradation results in the lowering of the tensile strength of a polymer.

Since both crosslinking and degradation occur simultaneously in most polymers, it is the relative tendencies toward the two reactions which determine the net result of irradiation. Thus, if crosslinking occurs at a higher yield than chain scission, the net result is crosslinking whereas if chain scission is predominant, the polymer degrades. Polymers which crosslink upon irradiation include polyethylene, polystyrene, polyacrylates, polyvinyl chloride, polyamides and polyesters—all polymers capable of forming nearly random coil conformation. Polymers which degrade upon irradiation include polyisobutylene, polymethacrylates, polyvinylidene chloride, polytetrafluoroethylene, polytrifluorochloroethylene and the cellulose—all polymers which

form stiff chains rather than random coil conformations.

The exact path by which radiation-induced crosslinking/scission reactions occur has been the subject of much discussion.^{1,5} The generally accepted mechanism involves the reaction of free radicals,^{6,7} although ionic mechanisms,^{8,9} have also been postulated. Furthermore, recent work on the irradiation of simple organic compounds allows one to postulate a mechanism for polymer crosslinking involving carbenes.¹⁰

2.2.2 The Factors Affecting Crosslinking

The factors which have been found to affect the crosslinking of polyethylene are as follows: dose, molecular weight, molecular weight distribution, density, crystallinity, temperature, irradiation atmosphere and the degree of branching of the polyethylene. These above variables are in general interacting and it is difficult to separate them for parametric studies on a commercial polyethylene. For instance, crystallinity itself is dependent upon molecular weight, the degree of branching and temperature. The effect of atmosphere (oxygen degradation) is dependent on the degree of branching, crystallinity and temperature. Fortuitously, there are a number of memory variables such as molecular weight distribution and molecular weight which affect the degree of crosslinking more than the other variables and commercial polyethylene can be classified roughly according to a given set of properties by knowledge of its density. What will now follow is an individual description of the

effects the variables have on crosslinking efficiency based on what parametric studies were found in the literature.

2.2.2.1 Dose

It has been found that the density of crosslinks (q) in an irradiated polymer, developed as described in Section 2.2.5, is directly proportional to the dose it receives

$$q = q_0 r \quad (2)$$

where q_0 is the crosslink density developed per 1 Mrad of irradiation, and

r is the radiation dose in megarads.

This follows since the crosslinks occur randomly and independently in the polymer. Since the crosslinks are distributed in a random manner, the average molecular weight between crosslinks (M_c) is given by

$$M_c = \frac{M_0}{q} \quad (3)$$

where M_0 is the molecular weight of a repeat unit in a polymer chain.

When the polyethylene is first irradiated it begins to develop branches (at ca. 0 to 3 Mrads) and at a higher dose (between 3 - 18 Mrads) the polyethylene begins to crosslink. The dose where crosslinking first occurs is called r_{gel} . (This is the dose where the first sign of an insoluble gel appears when the polymer is dissolved in a solvent.)

Quantitatively, how well a polymer crosslinks with dose is best measured by solvent extraction techniques. A cross-linked polymer is placed in a solvent (capable of dissolving the non-crosslinked polymer) at elevated temperature for a

period of time. The non-crosslinked fraction of the polymer (the sol-s) is then extracted out leaving the crosslinked matrix (the gel, $g = 1-s$). With the sols and corresponding doses known, theoretical procedures described in Section 2.2.3 can be used to determine q and M_c . When the crosslinking occurs, the molecules of high molecular weight crosslink easiest and first-with the low molecular weight chains always crosslinking more difficultly and, in fact, some never crosslink at all.

2.2.2.2 Molecular Weight

With the larger molecules determining when gelation first occurs, it was determined theoretically, that whatever the molecular weight distribution, three-dimensional network formation first begins to occur at a crosslinking density corresponding to one crosslinked unit per weight average molecule. Thus, the gel point is given by the equation

$$q \frac{M_w}{M_o} = 1 \quad (4)$$

where M_w is the weight average molecular weight.

If equation (2) is substituted into (4) it is then seen that the dose just causing gelation is

$$r_{gel} = \frac{M_o}{q_o M_w} \quad (5)$$

2.2.2.3 Molecular Weight Distribution

The effect of molecular weight distribution (MWD) on the crosslinking of a polymer is considerable. It has

been found in general that as the distribution becomes narrower the polymer crosslinks more efficiently.¹ The relative crosslinking efficiencies of different MWD's can best be seen from sol-dose curves. These curves are plotted in Figures 2 and 3, with sol fraction vs. crosslinking coefficient* with MWD as parameter. It appears that with a number average molecular weight (M_n) of above 10,000 a narrow distribution lends to more efficient crosslinking than a wider distribution with the same M_n because the wider distribution material contains a larger proportion of low molecular weight polymer-which does not crosslink readily. In a recent fundamental paper by Saito, Kang and Dole,¹¹ it was furthermore shown that for two polymers with the similar distributions (the same M_n and $\frac{M_w}{M_n}$ ratio) the one with a sufficiently high molecular weight "tail" on the end of its distribution will crosslink more efficiently. This again points out the beneficial effect the large molecules possess for crosslinking. It additionally means that a polymer with a somewhat broader MWD and a larger high molecular weight tail may crosslink

* The crosslinking coefficient (δ) is the number of crosslinked units per weight average molecule:

$$\delta = q \frac{M_w}{M_o}, \text{ hence it is also proportional to dose, viz.,}$$

$$\delta = \frac{M_w}{M_o} q_o r.$$

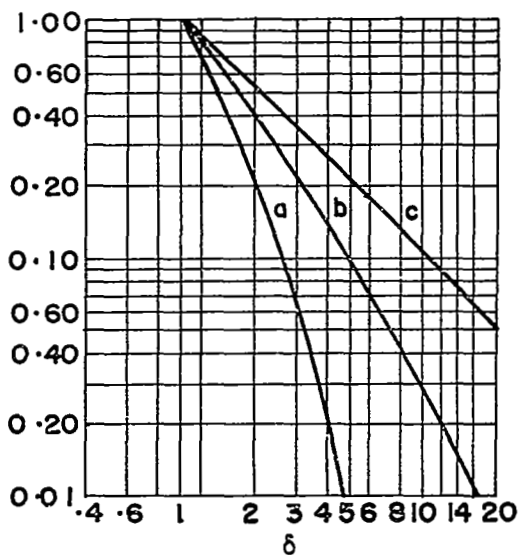

Fig. 2 DECREASE IN SOLUBLE FRACTION OF CROSSLINKED POLYMER WHEN δ EXCEEDS 1. (Reference 1)

- a. Initially uniform distribution
- b. Initially random distribution
- c. Initially pseudo-random distribution

When δ is less than unity the polymer is completely soluble in all cases.

Crosslinking coefficient δ = Number of crosslinked units per weight average molecule

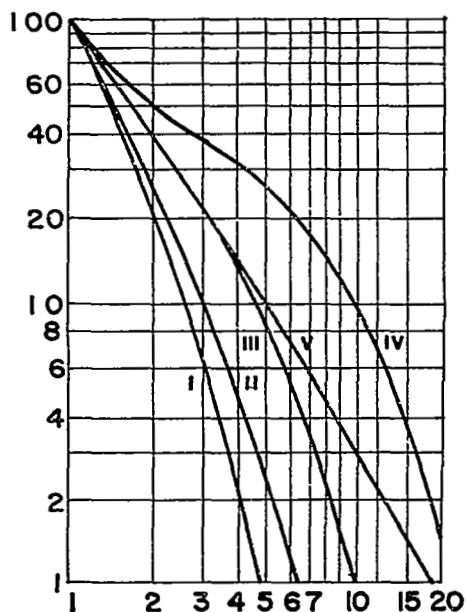

Fig. 3 SOME CALCULATED SOL- δ CURVES. (Reference 1)

- I. n molecules of uniform size.
- II. n molecules each containing u monomer units + n/2 molecules each containing 2u monomer units.
- III. n molecules with u monomer units each + n/4 molecules with 4u monomer units each.
- IV. n molecules with u monomer units each + n/10 molecules with 10u monomer units each.
- V. Random distribution.

Crosslinking coefficient δ

more efficiently than one with a narrower MWD and a smaller high molecular weight tail.

2.2.2.4 Crystallinity and Temperature

It is best to consider the effects of crystallinity and temperature together on the efficiency of crosslinking since crystallinity is itself a function of temperature. The problem, at a given temperature is to determine the efficiency of crosslinking in the crystalline region as opposed to the amorphous region. Kitaman, et al.,^{12,13,14} in a number of experiments crosslinking amorphous to very high percent crystallinity polyethylene and using extraction techniques, determined that the overall amount of crosslinking, Q , per given dose can be determined as follows:

$$\begin{aligned} Q &= \text{crosslinks in amorphous region} + \text{crosslinks in crystalline region} \\ &= [1 - \lambda(T)]k_a(T) + \lambda(T)k_c(T) \end{aligned} \quad (6)$$

where $\lambda(T)$ = fraction of crystallinity in a polyethylene material

$k_a(T), k_c(T)$ = number of crosslinks/dose produced in the amorphous and crystalline regions, respectively.

The function $\lambda(T)$ the fraction of crystallinity is given schematically in Figure 4, while the functions $k_a(T)$, $k_c(T)$ are given in Figure 5. The above results indicate that:

(1) At low temperature (below ca. 110°C.) crosslinking is more efficient in the amorphous region.

(2) Above ca. 125°C. crosslinking in the crystalline region is about twice as efficient as in the

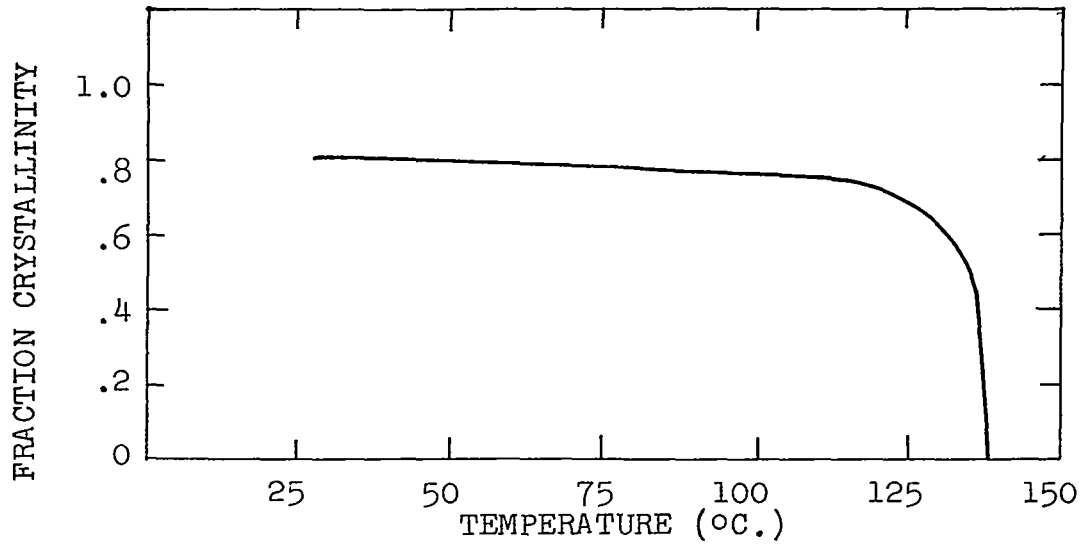

Figure 4 FRACTION CRYSTALLINITY OF POLYETHYLENE VS. TEMPERATURE (Ref. 17)

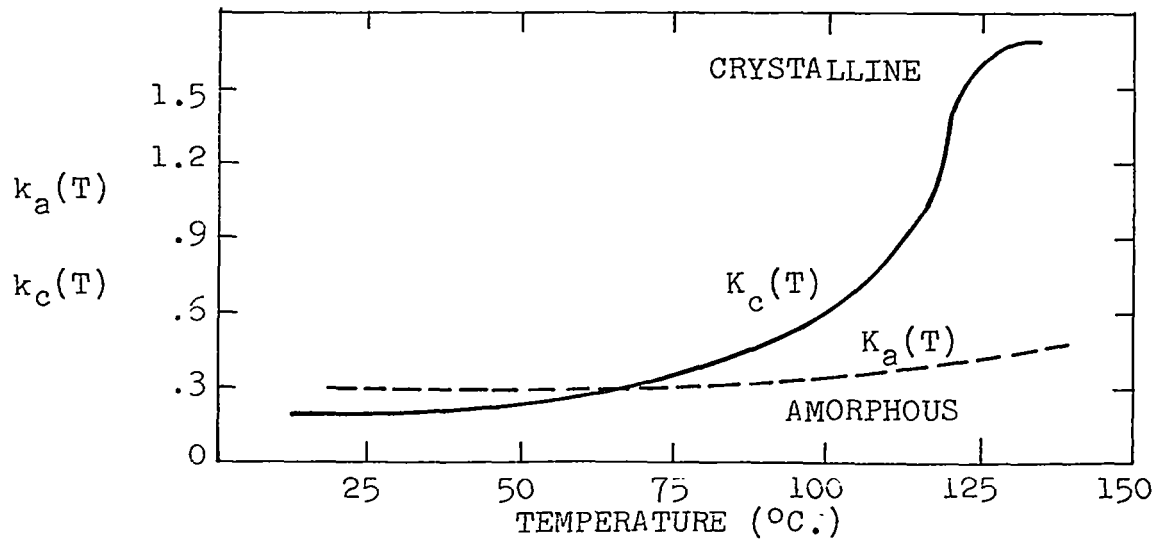
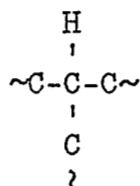

Figure 5 CROSSLINKING EFFICIENCY IN CRYSTALLINE AND AMORPHOUS REGIONS FOR POLYETHYLENE VS. TEMPERATURE (Ref. 17)

amorphous region.

2.2.2.5 The Degree of Branching

The degree of branching, whether of long chains or short chains adversely affects the efficiency of crosslinking. A branch point is automatically the site of a tertiary hydrogen



which when extracted by a striking β particle or γ ray leaves a relatively stable free radical which will not lend to couple with another free radical (to crosslink) but may tend to cleave (degrade, especially in the presence of oxygen). From the standpoint of the number of tertiary hydrogen per 100 mer units of unsaturated hydrocarbon polymers the following order of crosslinking efficiency would appear:

<u>Substance</u>	<u>Tert-H/100 mer units</u>
Polymethylene (pure straight chain polyethylene)	0
Polyethylene (branched)	ca. 0.2-6.0 (ref. 15)
Polypropylene	50

The effect of branching may additionally have an indirect effect on crosslinking in the sense that it affects the degree of crystallinity. Branching is one of the main factors that disrupts and prevents crystallinity by interfering with the orderly molecular packing of the

system. In this way the crystallinity of branched polyethylene may be lowered as much as 40% below that of linear polyethylene. The effect crystallinity has on crosslinking will be altered proportionally.

2.2.2.6 The Effect of an Oxygen Atmosphere

The presence of oxygen during irradiation is in general undesirable, since the presence of free radicals with the oxygen cause rapid oxidative degradation. This degradation effect is greatly pronounced on long-term irradiations, such as those needed when low intensity γ sources are used, or when the specimen being irradiated is very thin. In fact, with long times or thin samples a steady-state oxygen diffusion system is obtained which rapidly degrades the material being irradiated.¹⁶ It should be noted that the effects of oxygen are dependent on the crystallinity and amount of branching in the material. The more branching the more susceptible the polyethylene will be to oxidative degradation. As for crystallinity there are two considerations. A highly crystalline material will diffuse in less oxygen during the irradiation process, but it will be more conducive to the retention of trapped radicals which will then, over a period of time, even after the material is removed from the source of radiation, react with the slowly diffusing oxygen causing degradation.

2.2.3 Theoretical Determination of the Degree of Crosslinking

The degree of crosslinking can be determined quantitatively by measurement of the crosslinking density (q) or alternatively the molecular weight between crosslinks (M_c). A description of the method of determination is presented.

In general, when crosslinking efficiencies are determined, sol (s) or gel (g) is correlated with dose. The following treatment relating crosslinking density with gel is taken from the recent work of Saito, Kang and Dole.¹¹

The gel fraction, g , resulting from simultaneous crosslinking and scission in an irradiated polymer, with an arbitrary initial molecular weight distribution is given by the following equation:

$$1-g = (2g+\tau)^{-3}q^{-3} \left[4\tau q^2/P_n(o) + \tau^2 q^3(2g+\tau) - 4\tau q^2 g G_o(z) - 4q^3 g^2 (2g+\tau) \frac{dG_o(z)}{dz} \right] \text{ (ref. 27) } \quad (7)$$

where $q = y/P_n(o)$, the number of crosslinks per structural unit
 $y =$ the number of crosslinks per initial number average molecule
 $z = (2g+\tau)q$
 $\tau = P_o/q_o =$ the scission to crosslinking ratio
 $P_n(o) =$ the initial number average molecular size distribution, and
 $G_o(z) =$ the Laplace transform of the initial molecular size distribution, $m(P,o)$, i.e.,

$$G_o(z) = \int_0^{\infty} m(P,o) e^{-zP} dP$$

The molecular weight distribution that was found to best describe polyethylene is the Wesslau distribution.²⁸ It is given by the following equation:

$$m(P,0) = \frac{e^{\beta^2/2}}{\beta/\pi [P_n(0)]^2} \exp\left[-\frac{1}{\beta^2} \left(\ln \frac{P}{P_n(0)} e^{3\beta^2/4}\right)^2\right] \quad (8)$$

where β is an arbitrary positive number expressing the spread of the distribution.

Substituting the Wesslau distribution formula for $m(P,0)$ in Eq. (8) and the resulting value of $G_0(z)$ in Eq. (7) one obtains

$$\begin{aligned} & \left[\tau(1-\tau/4) + (1-\tau)g - g^2 \right] Z e^{-\beta^2/4} - \tau \\ & = g(2g+\tau) e^{\beta^2/4} I(Z e^{\beta^2/2}) - \tau I(Z) \end{aligned} \quad (9)$$

$$\text{where } Z = (2g+\tau) y e^{-\beta^2/4} \quad (10)$$

$$I(Z) = \frac{e^{-\beta^2/4}}{\beta/\pi} \int_0^\infty \exp\left[-\left(\frac{\ln n}{\beta}\right)^2 - (Z e^{-\beta^2/2})_n\right] dn$$

$$n = \frac{P}{P_n(0)} \exp(3\beta^2/4)$$

In the above equation n is the variable of integration, y is the number of crosslinks per initial number average molecule and g is the weight fraction of gel.

Equation (9) cannot be solved for g in closed form. Kang, Saito and Dole then solved Eq. (9) by computer, resulting in a tabulation of gel (g) versus the number of crosslinks per initial number average molecule (y)

with scission to crosslinking ratio (τ) and the index of the spread in molecular weight distribution (β) as parameters. Consequently, with τ and β known, y may be correlated with g . Since g can be determined experimentally with radiation dose (r), y can then be correlated with dose.

τ can be found by gel-dose data. It has been shown by Charlesby,¹ that s_+/s vs. $\frac{1}{r}$ is linear for a random molecular weight distribution. It has also been shown,²⁷ that at infinite dose, ($\frac{1}{r} \rightarrow 0$), $s_+/s \rightarrow \tau$, independent of the molecular weight distribution.

The index of the spread in the molecular weight distribution can be found directly from the various average molecular weights

$$\frac{M_w}{M_n} = \frac{M_z}{M_w} = \dots = e^{\beta^2/2}$$

With $y(r)$ known the molecular weight between crosslinks (M_c) may be found as a function of dose by its definition

$$M_c = \frac{M_o}{q} = \frac{M_o}{y/P_n(o)} = \frac{M_n(o)}{y} \quad (11)$$

2.3 Dimensional Stability - Annealing

The annealing study was included in the current program as a means of investigating any dimensional stability problems associated with the memory. The term "annealing" has been used in this instance since it was recognized that the initial state (i.e., the state in which

the material was irradiated) was not exactly recovered after a memory cycle. Hence, it was anticipated that an annealing step should proceed the irradiation to create a new initial state that would be reversible.

2.3.1 Shrinkage Mechanism-Oriented Crystallization and Contractility

In the absence of tension it is widely observed for crystallizable polymers that axially oriented crystalline systems contract upon melting. The mechanism of this contraction is based upon two equilibrium states defined by temperature and length. The oriented crystalline state at temperatures lower than the crystalline melting point is of large length as determined by the long oriented extended chain length of the polymer molecules. The amorphous state determined by the temperature above the crystalline melting point is of smaller length-determined by the much smaller extended chain length of the random coiled chains.

The macroscopic isotropic lengths above T_m (or the macroscopic amorphous lengths, as they are sometimes called) can be directly determined from the basic molecular properties of the material^{3,9,18}. The isotropic chain length is quantitatively defined by the following equation:

$$L_i = \frac{v}{\sigma'} \left(\frac{\bar{R}_0^2}{3} \right)^{\frac{1}{2}} \langle \alpha \rangle \quad (12)$$

where v = total number of chains in the network structure
or σ' = number of crosslink units in the network structure
 σ' = number of chains in a cross-section
 \bar{R}_0^2 = mean square end to end distance of an unconstrained chain
 $\langle \alpha \rangle$ = linear dialation factor

$$= \left[\frac{(\text{volume of chain in constrained state})^2}{(\text{volume of chain in unconstrained state})^2} \right]^{1/6}$$

Eq. (12) can be put in a more useful form by noting the following:

- i. volume of the system is constant = $V = \sigma' a L_R$
where a = the cross-sectional area of a polymer molecule
- ii. $v = \frac{1}{N} = \frac{M_0}{M}$ = number of crosslink units
- iii. qcv (crosslinking density α to the number of crosslink units)

Substituting i.-iii. in equation (12) one obtains

$$\frac{L_i}{L_0} = \frac{L_r}{L_0} \left[\frac{Na}{\sqrt{3M_0^{\frac{1}{2}}v}} \left(\frac{\bar{R}_0^2}{M} \right)^{\frac{1}{2}} q^{\frac{1}{2}} \langle \alpha \rangle \right] \quad (13)$$

where L_0 is the length of the specimen in the amorphous state in the absence of crosslinks.

Equation (13) has been experimentally demonstrated for polyethylene; shrinkage of crosslinked material, compared to the shrinkage of uncrosslinked material, can be

reduced up to 20 times. The above phenomena are shown schematically below:

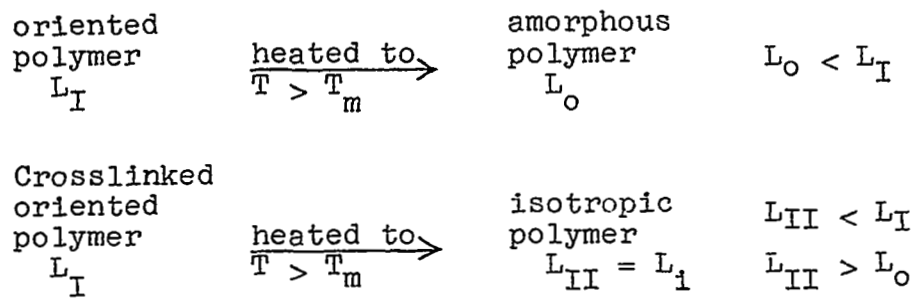

3.0 EXPERIMENTAL PROGRAM

The purpose of the experimental program was to investigate the properties of polyethylene material which, based upon the theory, affect the memory and to select a polyethylene material with properties which result in a superior memory material. In addition, the superior memory material that is selected is to have its properties thoroughly investigated. Specifically, the following aims were in mind:

1. Evaluate the properties of polyethylene material which can optimize the memory force.
2. Obtain a material which has good strength for handling at ambient conditions.
3. Obtain a material which can have 100% recovery and with manageable shrinkage.

The above investigations were to be done using only commercially obtainable materials. At the outset two problems were encountered. (1) On commercially available polyethylene, in either film or resin form, there is very little data available on their properties from the manufacturer. In fact, the only data usually available from the supplier is the density and melt index. (2) There is not enough of a variety of commercially available polyethylene materials to lend themselves for definitive parametric studies.

There are essentially two grades of polyethylene, high density (.95 - .97) and low density (.91 - .94) materials. The high density polyethylene is manufactured

by a low pressure (less than 500 psi) heterogeneous, continuous catalytic process or by a batch solution dispersion process at temperatures of 50°-75°C. The high density polyethylene is essentially made up of linear molecules which crystallize rapidly to ca. 85-95%. The low density polyethylene is manufactured by a high pressure (15,000-45,000 psi) continuous solution polymerization process at temperatures of up to 250°C. using traces of oxygen as the catalyst. The low density polyethylene is composed of branched molecules. The branching is mostly of the short chain nature consisting of ethylene and butylene side groups. Because of these side groups the branched polyethylene does not crystallize as readily as the linear substance, having a crystallinity of approximately 50-60%.

With density being the main correlating parameter distinguishing the different types of polyethylenes, it was decided to investigate a number of low and high density materials. Additionally, since molecular weight distribution appeared to be the most important property influencing crosslinking, it was decided to choose a number of materials with varying MWD's. To this aim it was necessary to first survey the polyethylene resin industry to determine what different polyethylene resins were available that could be manufactured into film. Twenty-five resins were screened first. Ten were rejected because they were not suited for film-forming or because of duplication. It was then

necessary to characterize fifteen (15) different films and resins selected to find those which were suitable and which had properties varied enough to be used to evaluate the effect these properties had on crosslinking and memory.

3.1 Initial Qualifications Tests

The following initial properties were evaluated: number average molecular weight* (M_n), weight average molecular weight (M_w) for M_w/M_n , the modulus of elasticity** at ambient temperature in the extrusion and transverse directions ($E_{//}$, E_{\perp}) and the density *** (ρ). Additionally, other factors relevant to the program, such as the ability to extrude and the availability of film in various thicknesses, were obtained from the manufacturer. The properties of the films investigated in this initial study are listed in Table 1.

With the initial evaluation completed, the following four materials were chosen:

Gulf 5555	, low density
DuPont Super C	, low density
Phillips 3328	, low density
Phillips 6003	, high density

* The initial number average and weight average molecular weights were measured by standard solution viscometric techniques.

** The modulus of elasticity was determined by an Instron tensile test according to the ASTM D-882 test method.

*** The density values were obtained from the manufacturer.

Table 1

Basic Properties of Initial Polyethylene Materials Investigated

Material	Density (gm/cc.)	M _n	M _w	M _w /M _n	E// (psi)	E/ (psi)	T _m (°C.)
Phillips 6002	.960	14,000	171,000	12.2	69,000	92,000	127
Phillips 6003	.960	30,000	195,000	6.5	82,000	85,000	130-131
DuPont 7030	.955	13,000	105,000	8.1			
Hercules 1900	.940-.942	-	3x10 ⁶		52,000	59,000	130-131
Phillips 3328	.933	10,000	83,000	8.3	33,000	30,000	118
Sea Space PE 12	.931	16,000	103,000	6.4	21,000	24,000	115
DuPont Super C	.926	30,000	90,000	3.0	23,000	28,000	121-122
Rexall 5735	.925	22,000	103,000	4.7	13,000	15,000	118.5
Gulf 5555	.925	20,000	73,000	3.7	27,000	16,000	112
U.C. 0602	.922	24,000	102,000	4.3	14,000	14,000	109
DuPont Super S	.921	21,000	107,000	5.1	19,000	18,000	116.5-117
U.C. 4140	.918	22,000	93,000	4.2	13,000	17,000	-
USI 107	.917	30,000	225,000	7.5	10,000	8,000	99-100
Phillips 1712	.917	28,000	210,000	7.5	11,000	11,000	102-103
USI 301	.917	29,000	200,000	6.9	11,000	12,000	101-102

The first two materials were chosen because of their low (but different) molecular weight distributions. The third material was chosen because it was of a density between the usual high and low types and consequently may represent a material of a different degree of branching than the lower density materials. The fourth material was chosen since it was one of the few high density materials that could be extruded into film.

3.2 Memory-Crosslinking Properties vs. the Basic Properties of the Four Materials

In order to determine the effects the molecular properties (of the four materials chosen for the study) had on the crosslinking-memory properties, the following were studied on the materials after crosslinking:

1. Gels - for crosslinking efficiency.
2. Modulus of Elasticity above the T_m at 140°C . - to measure the memory force.
3. The Memory - to actually test the memory effect.
4. Shrinkage - to determine the dimensional stability of the memory material.

The experimental procedures and results of the above studies will be described in the following sections, but before this is done a description of the production of the experimental, crosslinked materials will be given. The materials to be described were used throughout the entire program.

3.2.1 The Production of the Experimental, Crosslinked Polyethylene Films

3.2.1.1 The Production of the Polyethylene Films

Polyethylene films and sheeting in thicknesses

ranging from 0.85 to 65 mils were used on the program. Most of the thin gauge material (2 mil and below) was obtained from the manufacturer. The production procedures and type of film produced of these materials are listed in Table 2. The thicker films, 6-20 mils, which in general were not commercially available were produced in house by die extrusion. A 3 heating zone table model Brabender extruder (manufactured by the C.W. Brabender Co., Inc., South Hackensack, N.J.) with a L/D ratio of 20 and a screw of 1:2 compression ratio was uniformly used in all extrusions. Take up was done on an adapted blow film take up device at room temperature. The extrusion temperature, screw RPM and take up speed, depended on the resin used and gauge desired, were determined experimentally. Because of take up conditions and resin characteristics the shrinkage of the film varied from 2.75 in. to 3.5 in. from the initial 4-in. melt that was extruded.

3.2.1.2 The Irradiation of the Polyethylene Films

Most of the irradiation work, to crosslink the polyethylene film, was done on a 1.5 MeV electron accelerator.

Due to the fact that (a) electrons are continuously losing energy by interacting with the matter it passes through and (b) the high momentum electrons (such as those that have just entered a material) have much less of a tendency of back-scattering, the ionization or dose relationships with thickness is non-uniform, being 60% of maximum on the surface and increasing to a maximum within

Table 2

Processing Properties of the Films Used in the Program

Film	Gauges-Nominal (mils)	Process	Properties
33 Gulf 5555	1.0	Blown (Commercial)	Biaxially oriented
	6 - 7	Brabender Extrusion	Uniaxially oriented
	14 - 15	Brabender Extrusion	Uniaxially oriented
	20 - 24	Brabender Extrusion	Uniaxially oriented
Phillips 3328	65	Pressed	Isotropic
Phillips 6003	1	Brabender Extrusion	Uniaxially Extruded
	7	Die Extruded (Commercial)	Uniaxially Extruded
	14 - 15	Brabender Extrusion	Uniaxially Extruded
	20	Brabender Extrusion	Uniaxially Extruded
	65	Pressed	Isotropic
U.S.I. NA 107	1.0	Cast	Lightly oriented

the material. An experimental dose-depth relationship is shown in Figure 6 for 1.5 MeV electrons interacting with polyethylene. The dose-depth relationship in the figure does not show a maximum, since the depths studied were not sufficient enough to cause a net loss of energy by slowing down the electrons. Due to the non-uniformity of dose with depth, samples or bundles of samples were irradiated in total thickness of less than ca. 75 mils and the bundle was flipped over from back to front for half of the run to obtain a uniform total dose within the samples at the end of the run. To avoid heat build-up during the run, samples were irradiated in a number of discrete steps of approximately 5 Mrads per step. The temperature range for the irradiation was $80^{\circ} \pm 15^{\circ} \text{F}$. To minimize the degrading effect of oxygen the sample irradiations were carried out in sealed polyethylene bags which were purged with nitrogen. The dose was measured spectrophotometrically by use of blue-dyed cellophane dosimeters, with the color change measured on a Beckman spectrophotometer. The overall error in measuring the total dose is estimated to be within $\pm 8\%$.

3.2.2. Gel vs. Dose Study

One of the most effective methods of determining the efficiency of crosslinking is by means of extraction. The low molecular weight, uncrosslinked, fractions in the irradiated polyethylene film samples were extracted in xylene at $118^{\circ} \pm 3^{\circ} \text{C}$. for 60 hours. The antioxidant, n-beta-phenylnaphthylamine was added to the solvent to retard

Figure 6 EXPERIMENTAL DOSE-DEPTH RELATIONSHIP FOR 1.5 MeV ELECTRONS
PASSING THROUGH POLYETHYLENE

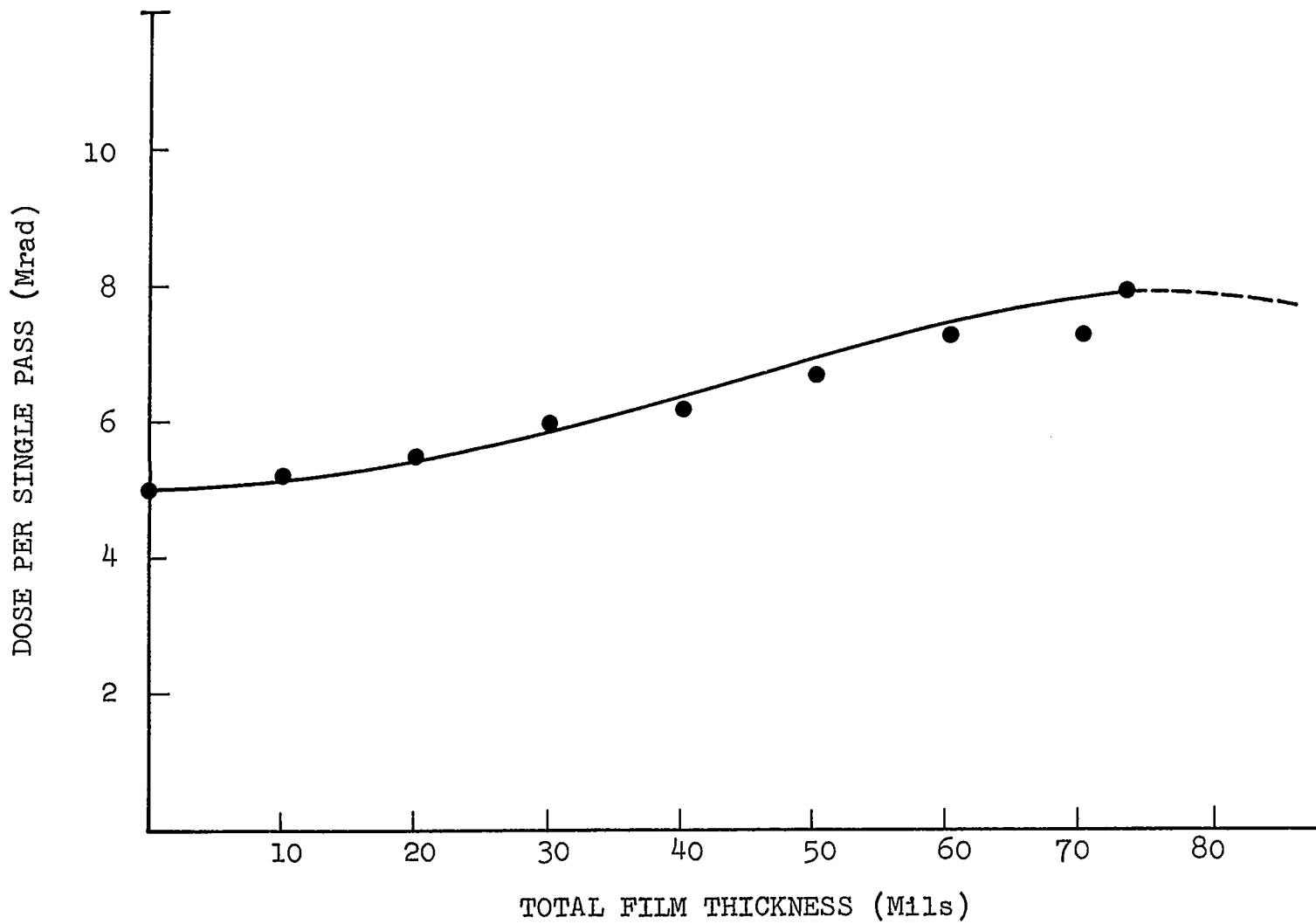

oxidation of the polyethylene during the extraction. In addition, the solvent was changed at the 24th and 48th hour to insure efficient extraction. The percent gel given by

$$\% \text{ gel} = \frac{\text{weight of material after extraction}}{\text{original weight of material}}$$

was determined for each sample at varying doses. A gel dose curve for each material was plotted in Figure 7 and according to the crosslinking extraction theory of Section 2.2.3 a

$s + s^{\frac{1}{2}}$ vs. $\frac{1}{r}$ curve was plotted in Figure 8. The more efficient crosslinking condition is indicated by a higher plateau level and more rapid increase of gel with dose. From Figures 7 and 8 it can be seen that the materials crosslink in the following order:

1. 5555
2. Super C
3. 3328
4. 6003

3.2.3 Modulus of Elasticity Above the Crystalline Melt Point vs. Dose

The modulus of elasticity above the crystalline melt point was determined in order to characterize the memory forces. For a crosslinked polymer, above its crystalline melt point, the modulus of elasticity is a direct measure of the crosslink, rubber elastic, forces have been described in Section 2.1. The modulus can be looked upon as a spring constant which can restore a deformed material to its original shape. A temperature of $140^{\circ} \pm 2^{\circ}\text{C}$. has been used on hot modulus determinations since it is above the highest T_m for any type of

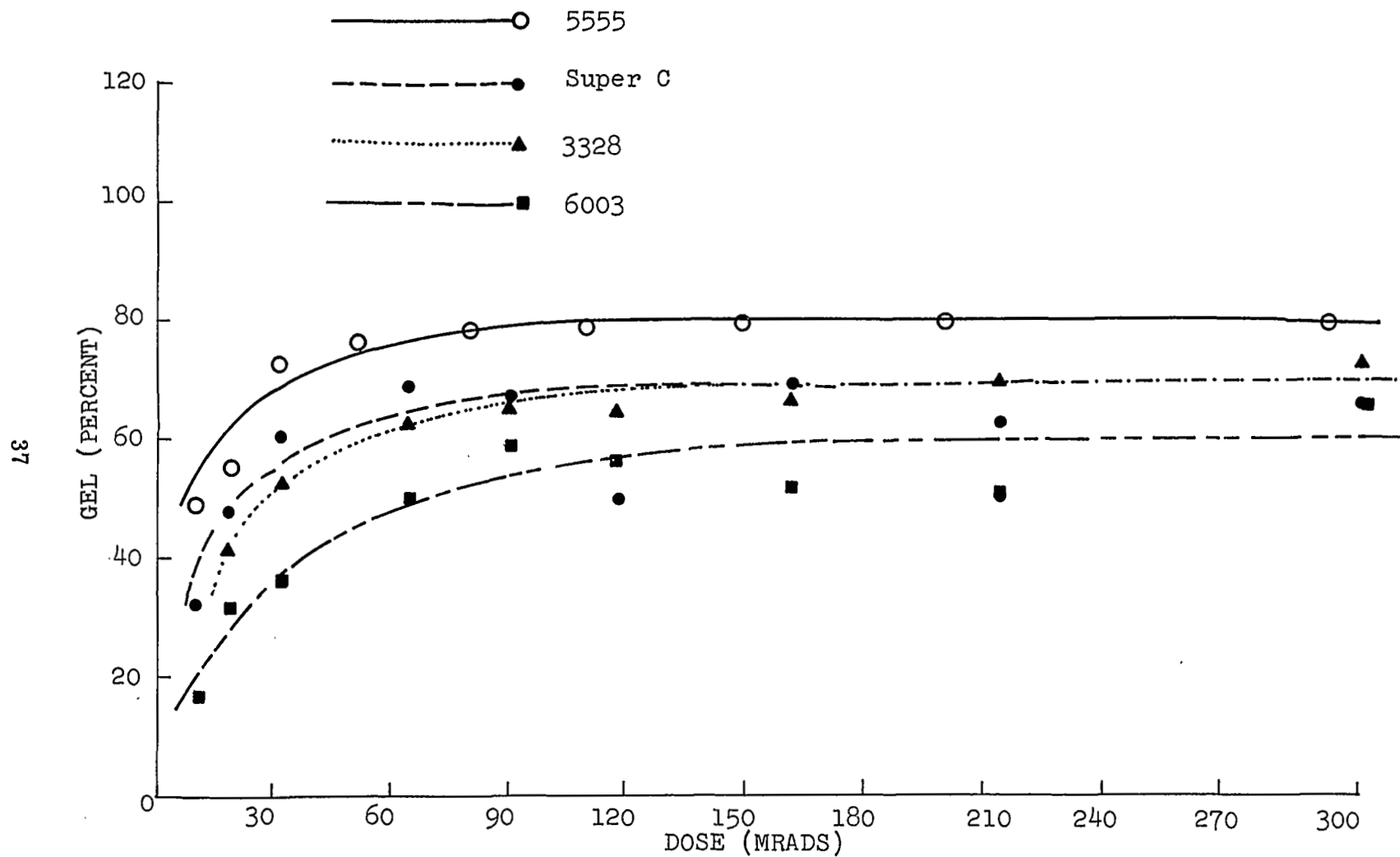
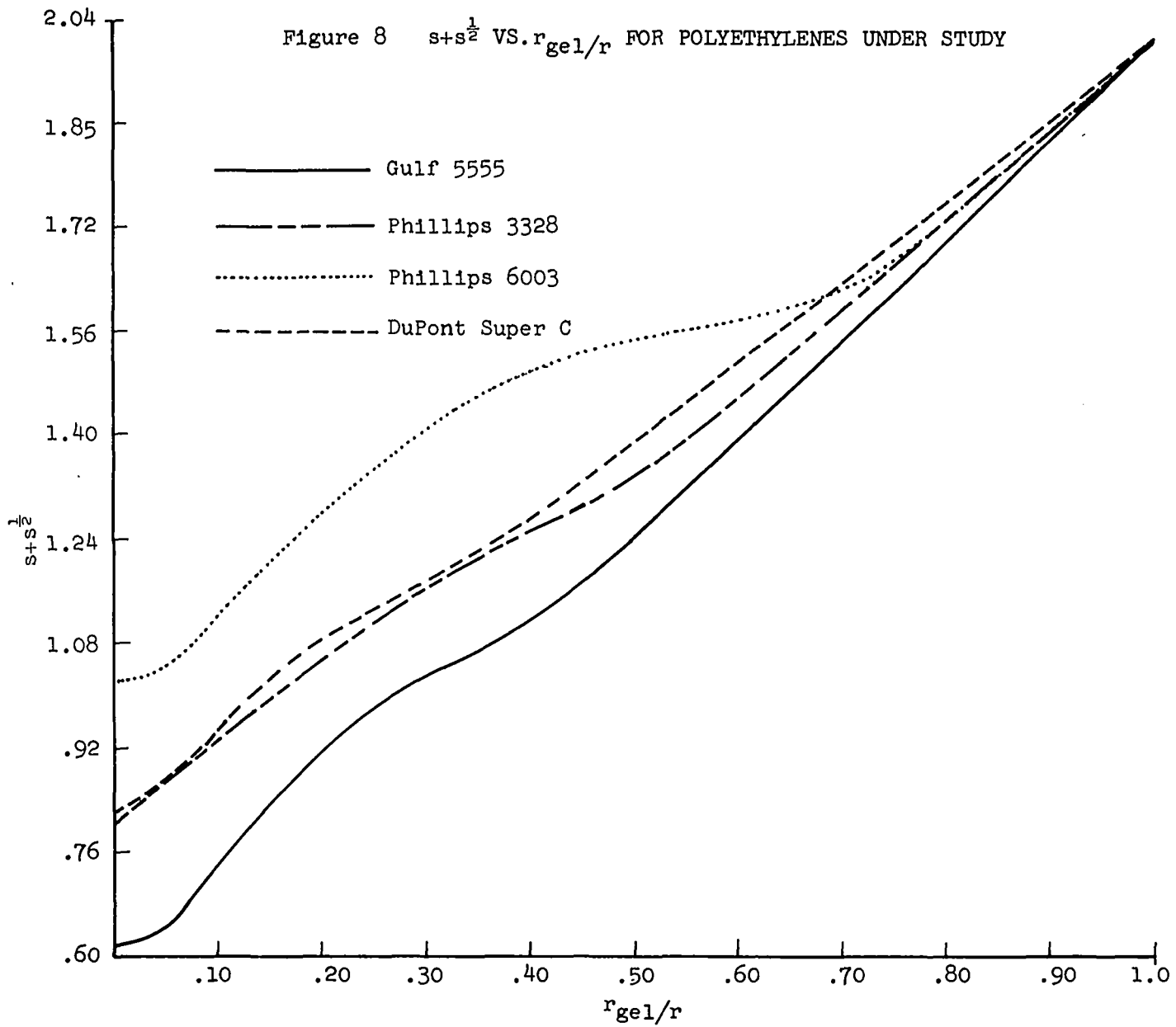

Figure 7 GEL FRACTIONS VS. DOSE FOR CROSSLINKED POLYETHYLENES UNDER STUDY



polyethylene. All the moduli were measured on an Instron tensile tester at a 0.2 in./min. strain rate. The sample sizes were 1 in. x 1 in.* The moduli determined for the materials under investigation are presented in Figure 9 where it can be seen that the order of memory force is as follows:

Phillips 6003
 Gulf 5555
 Phillips 3328
 DuPont Super C

3.2.4 Memory vs. Dose Study

The memory experiments on this project involved the determination of the restoration behavior of deformed polymer specimens of various doses and thicknesses. Specimens were deformed by bending and then folded to the desired angle of deformation (always less than 5°). The folded specimens were then heated with the fold kept in place by weights. The specimens were then cooled (quenched) to "freeze" them into their deformed shape. A schematic diagram of the folding procedure is shown as follows:

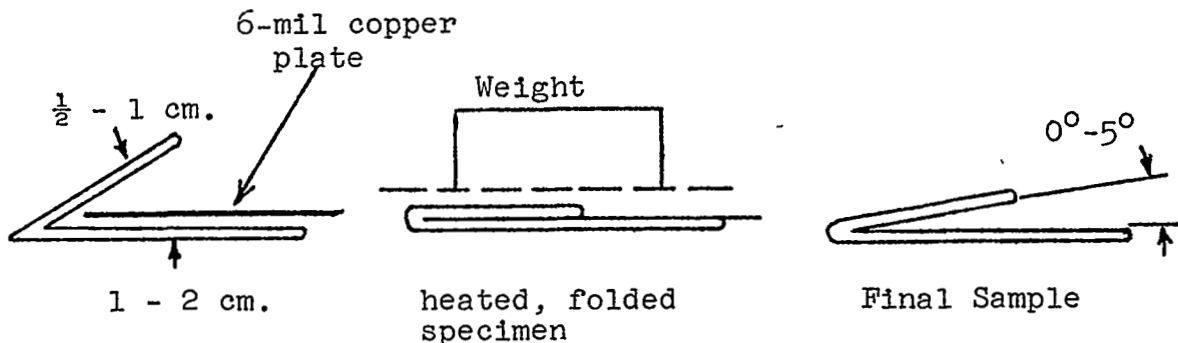

* In a limited number of cases the standard sample length of 5 in. was tested. In general it was found that there was a less than 5% difference so the more convenient 1 in. length was predominantly used.

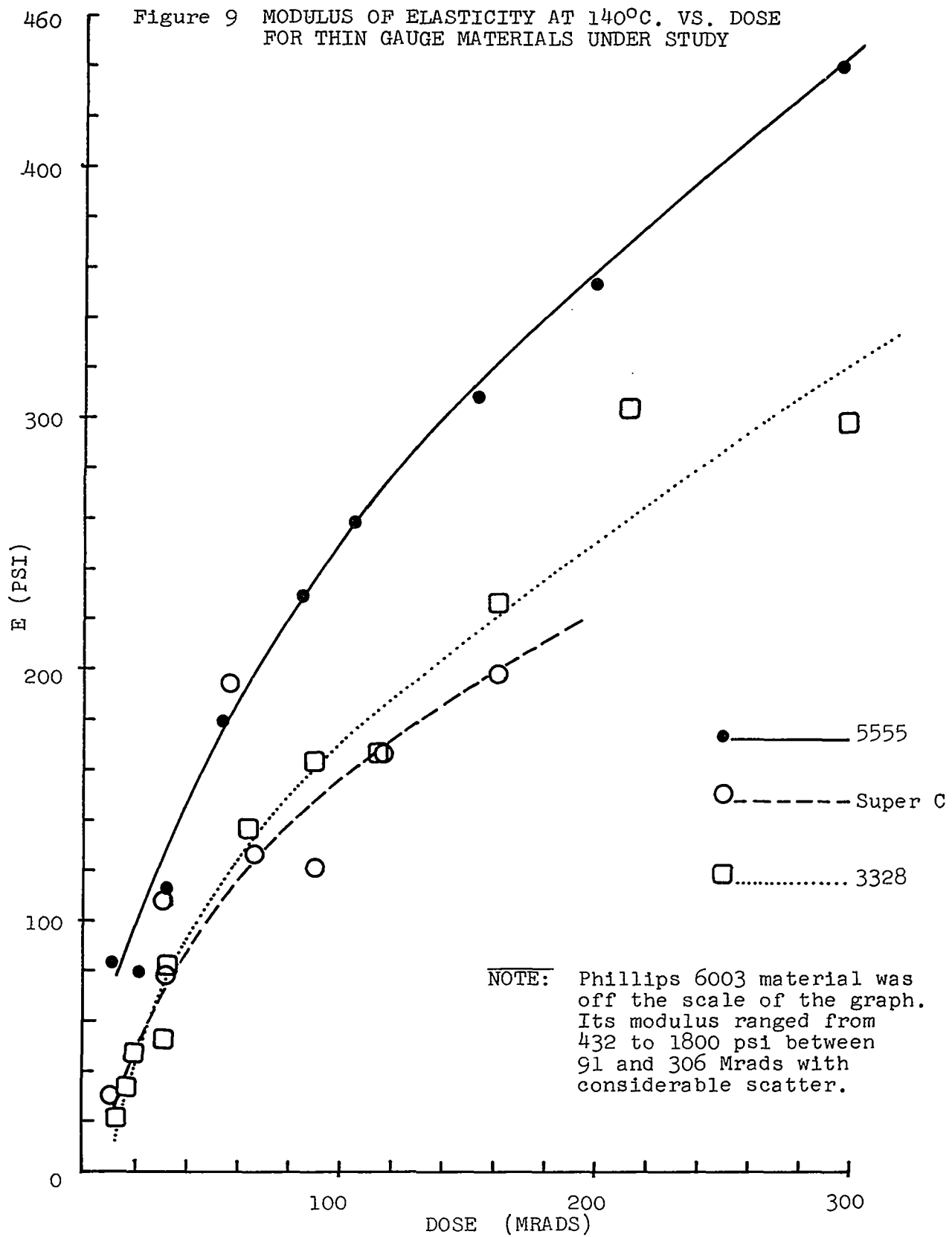

The long arm of the sample is then placed in a wrinkle recovery tester described in the ASTM D 1295-60 test method and shown in Figures 10 and 11. The smaller arm of the nearly 180° deformed sample is left free to restore and it is always kept in a vertical position to negate gravitational effects during recovery. This is shown in Figure 10. Since the test is conducted above ambient the wrinkle recovery tester apparatus is in an oven. The oven is then heated in the temperature range of 135⁰±3⁰C:-a range above the T_m of all materials studied (see Table 1). Once heating has begun, recovery is observed and reaches a maximum after the sample is above its crystalline melt point. The restoration was reported as percent recovery as follows:

$$\text{percent recovery} = \frac{\text{final angle} - \text{initial angle}}{180^{\circ} - \text{initial angle}}$$

Samples of thicknesses ranging from 1 to 22 mils and doses ranging from 11 to 85 Mrads were tested for memory. The varying thicknesses were used since the restoring moment of the memory force is thickness dependent-since the outer radius of a thick folded sample will be in a greater state of strain than a thin one. The varying doses were used since different doses yield different degrees of crosslinking which consequently yield different amounts of spring to the materials.

The results of the memory tests are presented in Table 3 where it is seen that the materials under study attain 100% recovery in the following order:

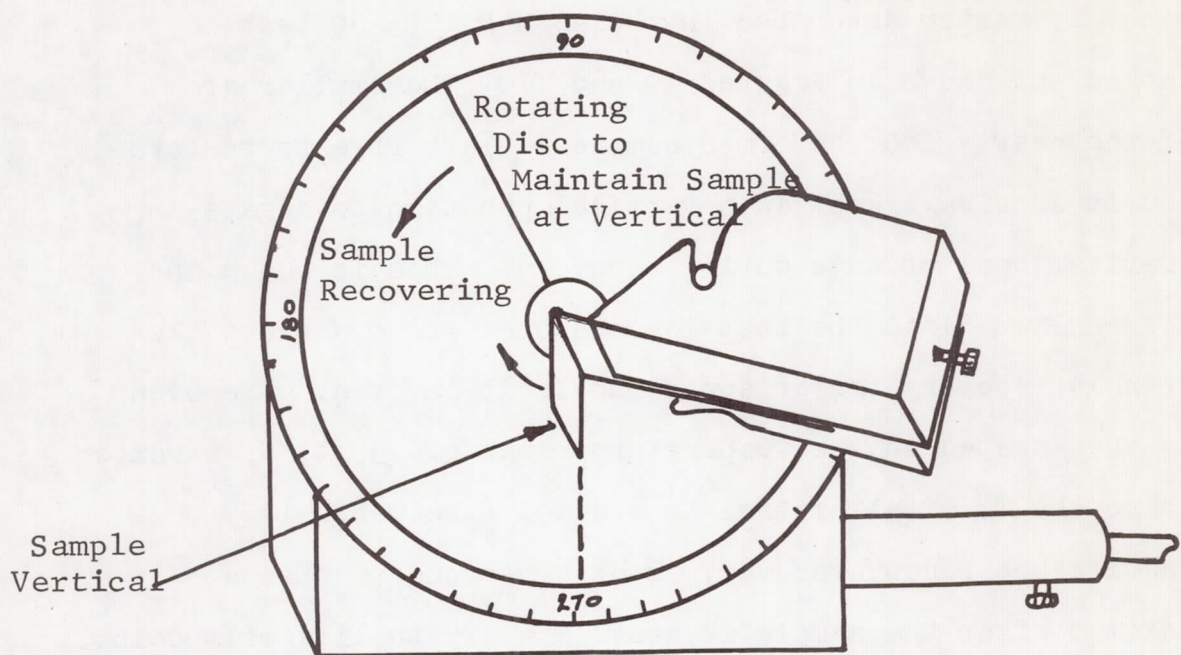

Figure 10. WRINKLE RECOVERY, "MEMORY", TESTING APPARATUS-SCHEMATIC

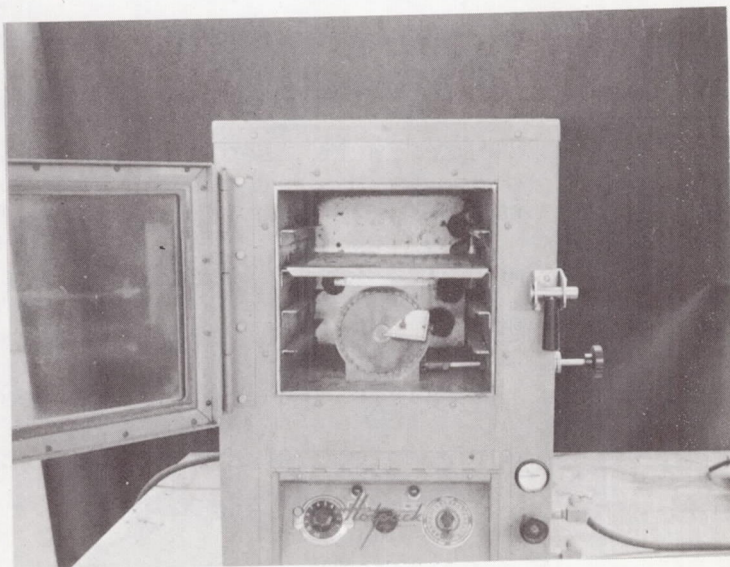

Figure 11 WRINKLE RECOVERY, "MEMORY", TESTING APPARATUS-PHOTOGRAPH

Table 3

Memory vs. Dose with Thickness as a Parameter
for the Materials under Study

Material	Dose (Mrads)	PER-CENT RECOVERY			
		Thickness (mils)			
		1.5	7	14	22
Gulf 5555	11		92	100	100
	12	<90			
	21	100	100	100	100
	32	100		100	100
	54		100	100	100
	58	100	100		
	85	100	100	100	100
		Thickness (mils)			
		1.25	7	14	22
Super C	12	73			
	21	100	96	100	100
	32	90	100	100	100
	54		100	100	100
	58	100			
	85				
		Thickness (mils)			
		1	7	14	22
Phillips 3328	21	96	100	100	100
	32	91	100	100	100
	54	100	100	100	100
		Thickness (mils)			
		1.5			
USI NA 107	11	96			
	21	100			
	32	100			
	54	100			
	85	100			
		Thickness (mils)			
		1	6	12.5	22
Phillips 6003	11	95*	98*	100*	100*
	21	100*	95*	88*	85*
	32	97	98	100	100*
	54	100	83*	100	100*
	85	100	84*	100	100

* Completely recovered when removed from oven, but severe warps and creases.

USI NA 107
Gulf 5555
DuPont Super C
Phillips 3328
Phillips 6003

The role the USI NA 107 film had in this evaluation in conjunction with dimensional stability problems will presently be discussed. It was found for certain materials, namely 6003, that some interference to the memory phenomenon was occurring. The interference observed was a loss in dimensional stability during a memory test. The loss in dimensional stability was due to extrusion induced alignments of the long chain molecules in the polyethylene film. When the film is heated these chains have a tendency to relax, even with crosslinking, resulting in some shrinkage in the extrusion direction and some expansion in the transverse direction. This phenomenon resulted in the wrinkling of some samples when the memory test was performed. This, in turn, resulted in difficulty in determining the final restoration angle (see schematic diagram below) and tended to give low results on some samples.

This interference was most pronounced in 6003, less noticeable in 3328, much less apparent in Super C and 5555, and virtually non-existent in NA 107. It is believed that these observations can be explained in terms of extrusion induced alignments. Both 6003 and 3328, as can be seen by their densities and moduli of elasticity (at ambient temperature), are highly aligned materials.

On the other hand, the other three materials are less aligned with NA 107, a cast film, being relatively unaligned. This was the first time dimensional stability problems occurred upon the implementation of a memory cycle. This problem, and the theory of "Dimensional Stability - Annealing" discussed in Section 2.3, led to the idea of using an annealed material or an unoriented material at the start of a memory cycle. These shrinkage - dimensional stability problems and results are discussed in the following section.

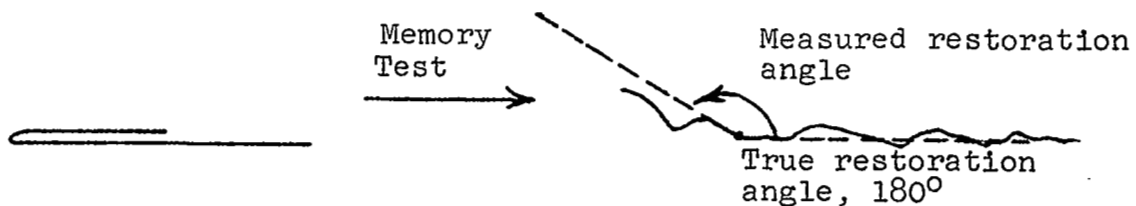

a) Extrusion induced interference with memory phenomenon

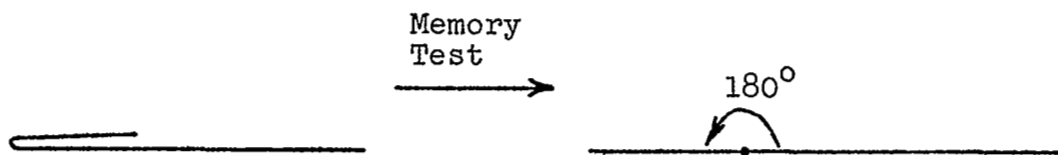

b) Demonstration of memory with no interference

DISTORTIONS OF SAMPLE DURING AND AFTER RECOVERY DUE TO EXTRUSION INDUCED ALIGNMENTS

3.2.5 Shrinkage vs. Orientation Study

With the observation from the memory study that film with the least orientation has the best dimensional stability when taken above its crystalline melt point, a number of more formal experiments were performed to test this hypothesis. Shrinkage tests were performed on two materials at different doses (11 to 200 Mrads). The two materials chosen were the Gulf 5555 (1.5 mil) and the U.S.I. NA 107 (1.0 mil). The other three films were not considered here because the DuPont Super C is much like the Gulf 5555 and the Phillips 6003 and 3328 tended to shrink to a large degree. Circles of 2-7/8 in. diameter of the film materials were heated to 140°C. in an unrestrained condition. They were then cooled to room temperature and their dimensions were measured in the extrusion and transverse directions. The results are presented in Table 4. It was found in general that the circles became ellipses with minor axes in the direction of extrusion (from shrinkage in the extrusion direction). It can be seen from Table 4 that the most shrinkage occurred on the materials with highest orientation and lowest doses. This is directly in accord with theory where oriented polymer molecules will tend to return to a more random coil- with consequently more shrinkage. Counteracting this is the effect of crosslinkages-the more crosslinkages the more the orientation will be preserved. It has been found¹⁷ that orientation is the more predominant effect.

Table 4

Dimensional Stability of Films of Different Orientation
upon Completion of a Memory Cycle

Dose (Mrads)	GULF 5555		NA 107	
	% Change		% Change	
	Extrusion Direction*	Transverse Direction**	Extrusion Direction*	Transverse Direction**
11	-40	+14	-20	+8
21	-22	+13	-9	+5
32	-17	+10	-8	+7
54	-12	+10	-4	+9
85	-6	+9	-7	+5
200	-6	+5		

* Minor axis of ellipse

** Major axis of ellipse

Further studies were conducted on the dimensional stability of extruded and pressed Gulf 5555 film. Two approaches were tried: (1) Producing a stress free unoriented material by pressing; (2) Annealing the crosslinked oriented film to obtain a material that will have dimensional stability while being employed in a memory cycle. The results of these studies are as follows.

Pressing - It has been demonstrated that 2-3 mil pressed film in doses upward of 11 Mrads maintains complete dimensional stability when annealed to 140°C. On the other hand, as has been shown in Table 4, the 1.5 mil extruded film exhibits major dimensional changes when annealed to 140°C. With increased dose, it can be seen from Table 4 that these changes decrease, but even with a dose of 200 Mrads there is a clearly observable dimensional change. Once the film is annealed it maintains its original annealed configuration upon subsequent heating.

Annealing - Once a film with a dose of above 11 Mrads is annealed, it maintains its original annealed configuration upon subsequent heating. Wrinkling and creasing has been a problem on film irradiated below 85 Mrads, when it is annealed unrestrained. It has been found that slightly restraining the film by placing a thin plate over it during the annealing eliminates these distortions. When restrained in this manner it is necessary to anneal the film again, but unrestrained. This second unrestrained annealing produces few distortions (only attributed to slight sticking to plate) in the film and allows the film to assume its final state. An alternative procedure is to anneal the crosslinked film unrestrained and then reannealing it while restrained on a cylinder, being held in place by wrapping teflon film around it. It is found that after the last annealing the film has acceptable dimensional stability.

3.2.6 Discussion of Experimental Results

3.2.6.1 Gels

As discussed in Section 2.2.2 the main factors that affect the efficiency of crosslinking are molecular weight and molecular weight distribution. Based on gel fraction measurements, it has been shown in the previous section, that the materials under study crosslinked in the following order:

Gulf 5555
DuPont Super C
Phillips 3328
Phillips 6003

This can also be seen from the M_c -dose curves for these materials plotted in Figure 12 according to equation (11) of the theory. In order to conclusively show that it is in fact molecular weight and molecular weight distribution that affects the efficiency of crosslinking, the actual molecular weight distributions (calculated as log molecular weight distributions) were determined by Gel Permeation Chromatography (GPC) techniques (which are discussed in Appendix I). The log molecular weight distributions for the four materials under study are presented in Figure 13, with their average molecular weights listed in Table 5. In addition, infrared spectra were determined on the films under study to determine if there are differences in the number of short chain branches for the different materials - since short chain branching also affects the crosslinking properties by being a degrading influence. It was found that for the low density materials their I-R spectra were nearly identical, thereby indicating no chemical differences. The high density material being made of linear molecules has no branching. With the effect of branching virtually eliminated, it is then seen that molecular weight distribution does, indeed, play a major role in the efficiency of crosslinking. As can be seen from the MWD curves the Gulf 5555 which crosslinks best does have the narrowest MWD. It is additionally seen that the Phillips 6003 film which is a linear polymer and does not have the adverse effects of branching, but does have the widest MWD, crosslinks the least efficiently.

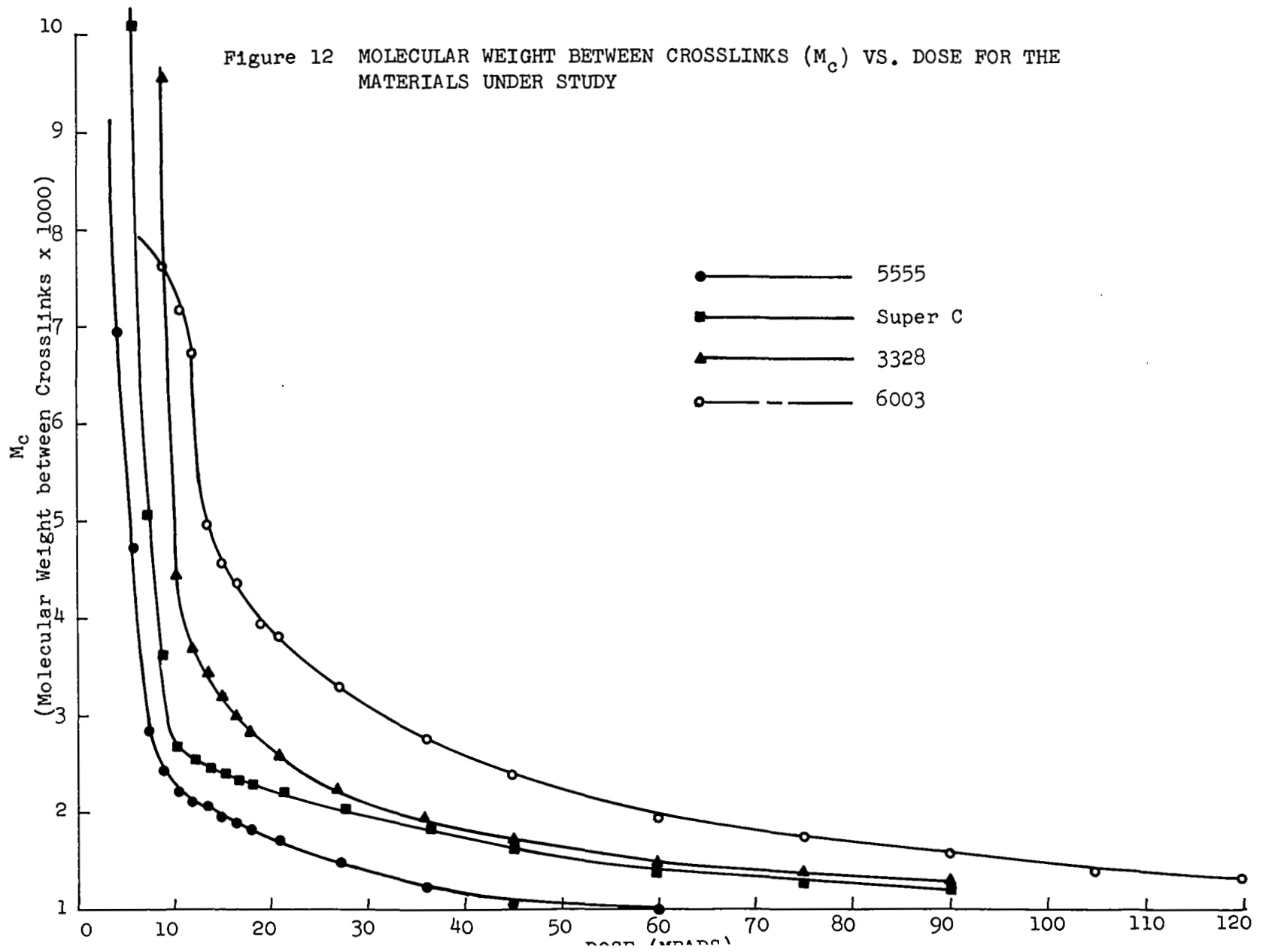

Figure 13 LOG MOLECULAR WEIGHT DISTRIBUTIONS OF THE POLYETHYLENES UNDER STUDY

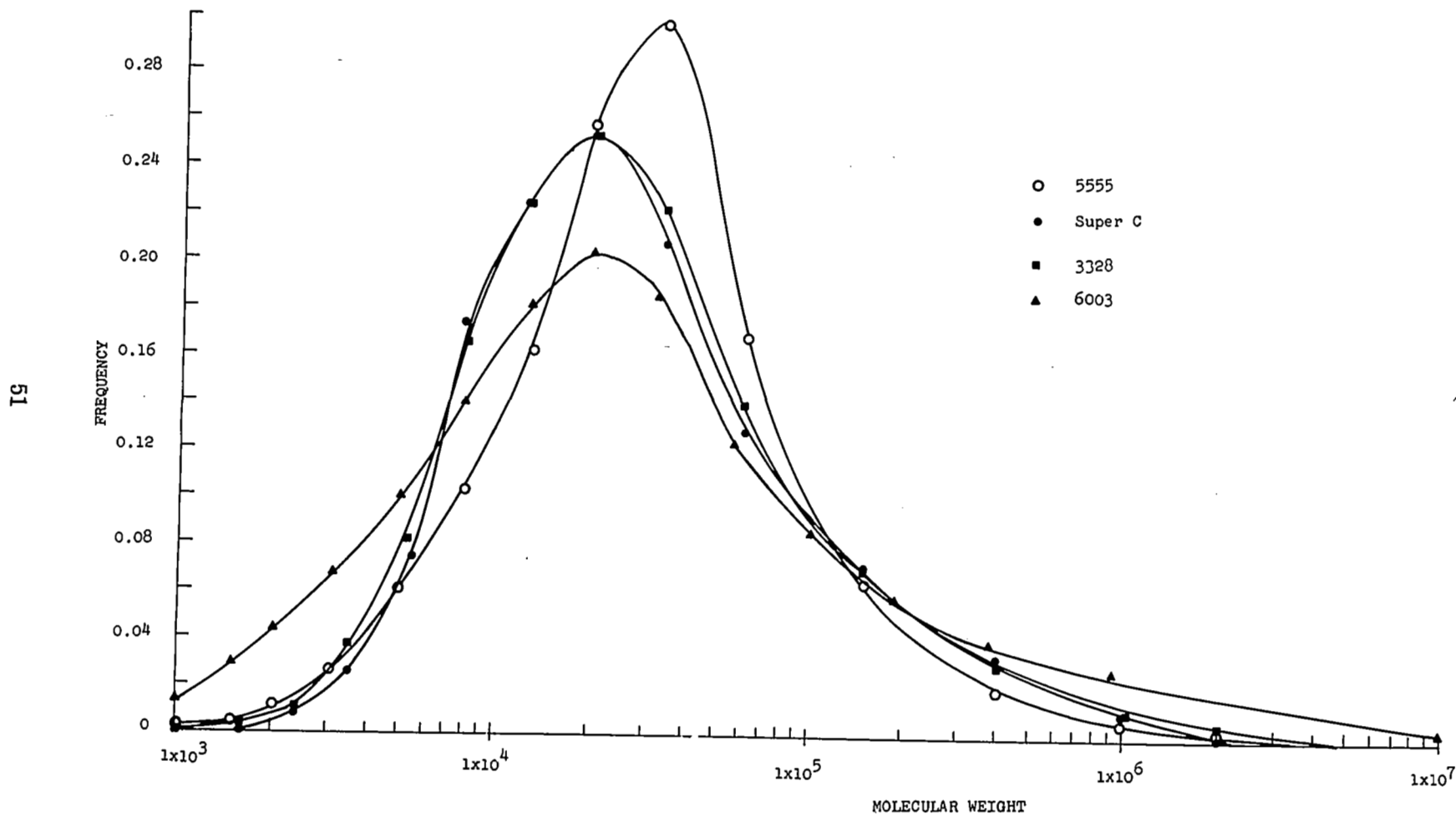

Table 5

Summary of Molecular Weights and Distributions for Various Test Methods

Material	Viscosity			GPC		
	M_n x 10 ³	M_w x 10 ³	M_w/M_n	M_n x 10 ³	M_w x 10 ³	M_w/M_n
Gulf 5555	20	73	3.7	14.6	50	3.5
DuPont Super C	30	90	3.0	14.2	56	4.0
Phillips 3328	10	83	8.3	13.4	55	4.1
Phillips 6003	30*	195*	6.5	8.5	113	13.3

*Data obtained from manufacturer

3.2.6.2 Modulus of Elasticity

As has been shown in Section 2.1 of the theory the modulus above the T_m is dependent on the crosslinking density (M_c), the orientation $\langle\alpha\rangle$, the average molecular weight M_n and the entanglement factor g .

It is seen from Figure 9 of Section 3.2.3 that the modulus increases at a given dose according to crosslinking efficiency with one exception, the Phillips 6003 material has a higher modulus than the others despite the fact that it has the poorest crosslinking efficiency. This is most likely due to the fact that it is the most oriented of all the materials under study (giving it a higher $\langle\alpha\rangle$). Furthermore, the Phillips 6003 film contains a large fraction of high molecular weight molecules (viz., its high M_w compared to the others) allowing it to more easily obtain entanglement crosslinks giving it a higher g than the others.

3.2.6.3 Memory

Despite the fact that the "memory" force of the Phillips 6003 is higher than the others it cannot be considered to be the material possessing the best memory properties. This is so since the material is of high orientation and tends to severely shrink, warp and wrinkle when heated above its T_m , and cannot be returned to its original shape. The other three films, all low density materials produced with approximately the same degree of orientation, consequently had their memories determined

by their crosslinking properties alone; hence the order of efficiency of restoration for the films under study was found to be:

Gulf 5555
DuPont Super C
Phillips 3328
Phillips 6003

3.2.6.4 Dimensional Stability

It is seen that dimensional stability is directly dependent on the orientation that the film has when it is crosslinked. It has been experimentally found that the resulting dimensional change from this orientation may be removed by two methods-(1) using a non-oriented material (such as pressed film) or (2) annealing. In summary, the following results have been obtained in observing the dimensional changes in going through a memory cycle.

Pressed film: no change
Extruded film (annealed): no change
Cast film: 4-20%
Extruded film: 6-40%

The present elucidation of the shrinkage mechanism (Section 2.3.1) and the experiments described make it possible to control dimensional stability in two ways. The first method recommends using non-oriented materials eliminating shrinkage entirely. This method is particularly useful for molded, pressed and cast polyethylene objects. The other method recognizes that the initial state before the first memory cycle is not a crystalline equilibrium state and consequently recommends an annealing step to create a crystalline equilibrium state for all memory cycles

to follow. This method of dimension control is useful for polyethylene objects produced by all methods including extrusion.

4.0 DETAILED EVALUATION OF FINAL MATERIAL

With the evaluation of the important factors that determine the memory, the selection of Gulf 5555 was made. The Gulf 5555 material was then studied in further detail. A detailed examination of the mechanical and memory properties was undertaken along with a number of environmental tests.

4.1 Mechanical Properties of Gulf 5555 Polyethylene Film

The following mechanical properties of Gulf 5555 were determined:

- Stress-strain curve - for uncrosslinked material at ambient temperature.
- Stress-strain curve - for material crosslinked to 90 Mrads at 140°C.
- The modulus of elasticity vs. dose with thickness as a parameter at 140°C.
- The modulus of elasticity vs. temperature with dose as a parameter above 110°C.

4.1.1 Stress-Strain Curve for Uncrosslinked Material at Ambient Temperature

The stress-strain ($\sigma - \epsilon$) curve for the 1.5 mil Gulf 5555 uncrosslinked film was determined four times each in the extrusion and transverse directions at ambient temperature using the standard Instron tensile test (ASTM D 882). The result is presented in Figure 14. It should be noted that the uncrosslinked film was used since it has been found that the tensile strength well below the T_m does not significantly change with dose due to the fact that the crystalline restraints in the material are far more numerous than the crosslink restraints.

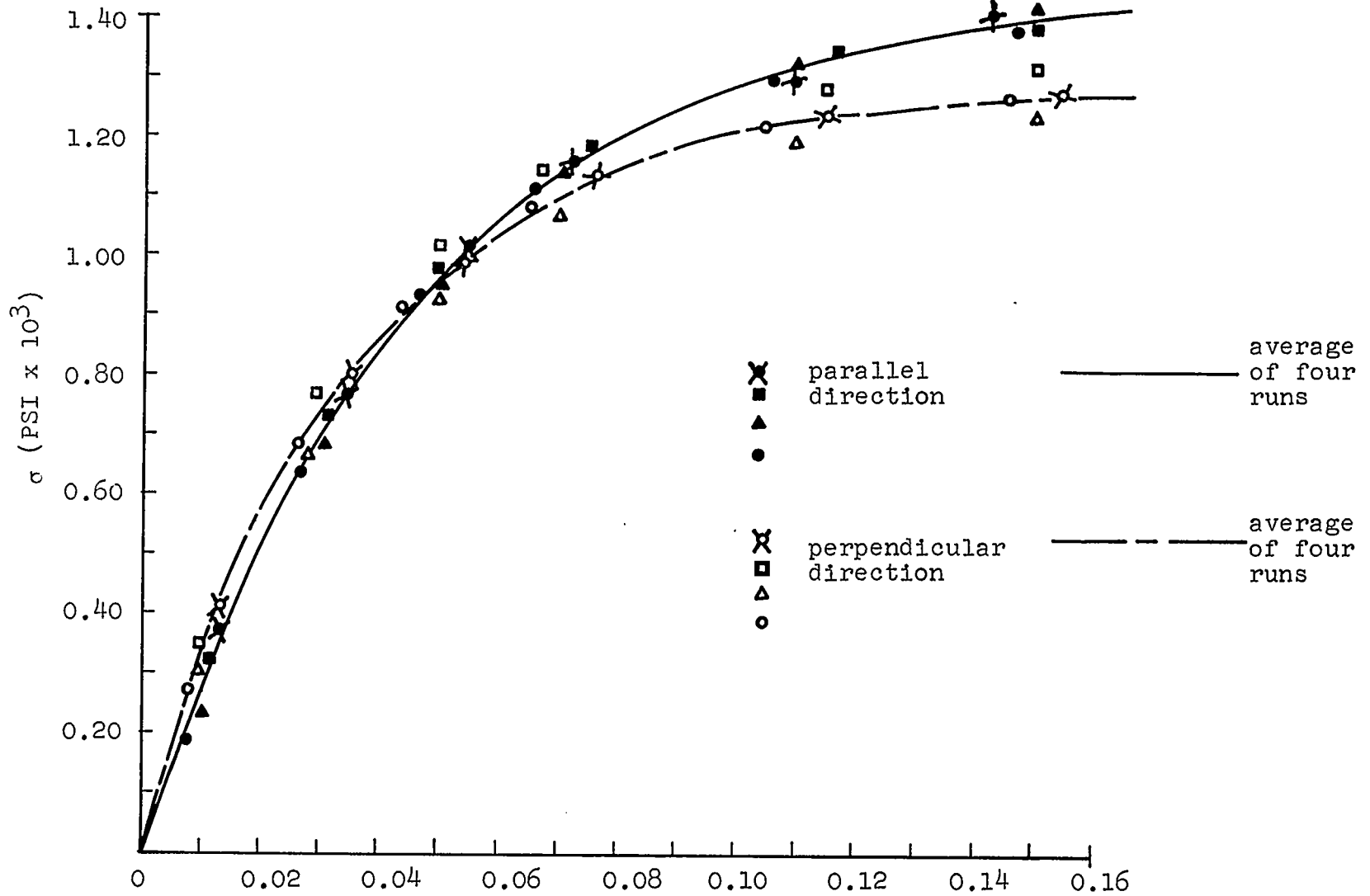

Figure 14 STRESS-STRAIN CURVES FOR UNCROSSLINKED GULF 5555
1.5 MIL POLYETHYLENE FILM AT AMBIENT TEMPERATURE

4.1.2 Stress-Strain Curve for Crosslinked Material at 140°C.

The $\sigma - \epsilon$ curve for the 1.5 mil Gulf 5555 material crosslinked to 90 Mrads was determined three times at 140°C. again using standard tensile test methods. The results are shown in Figure 15. The 90 Mrad level was chosen to be a representative material since it was the mid range dose used in the study and it was the lowest dose that helped to minimize shrinkage.

4.1.3 Modulus-Thickness Evaluation at 140°C.

The modulus of elasticity (in the extrusion direction*) at 140°C. of the Gulf 5555 film has been determined as a function of dose with thickness as a parameter. The dose was in the range of 0 to 300 Mrads; while the thicknesses used were 1.5, 7, 14 and 25 mils (all nominal values). It was found (see Figure 16) that the modulus increased essentially linearly (except for the 1.5 mil material) with dose for the thicknesses investigated. Additionally, at any constant dose, the modulus was greater the larger the thickness. In general, the effect of thickness is small only increasing ca. 10% every 7 mils.

For ordinary materials the modulus of elasticity usually does not vary with the thickness of the sample measured. For the case of polyethylene film it may vary

*The transverse direction was not investigated since the difference in modulus above the T_m was found to be less than 5%. Only the 1.5 mil film showed large anisotropy (see Figure 15).

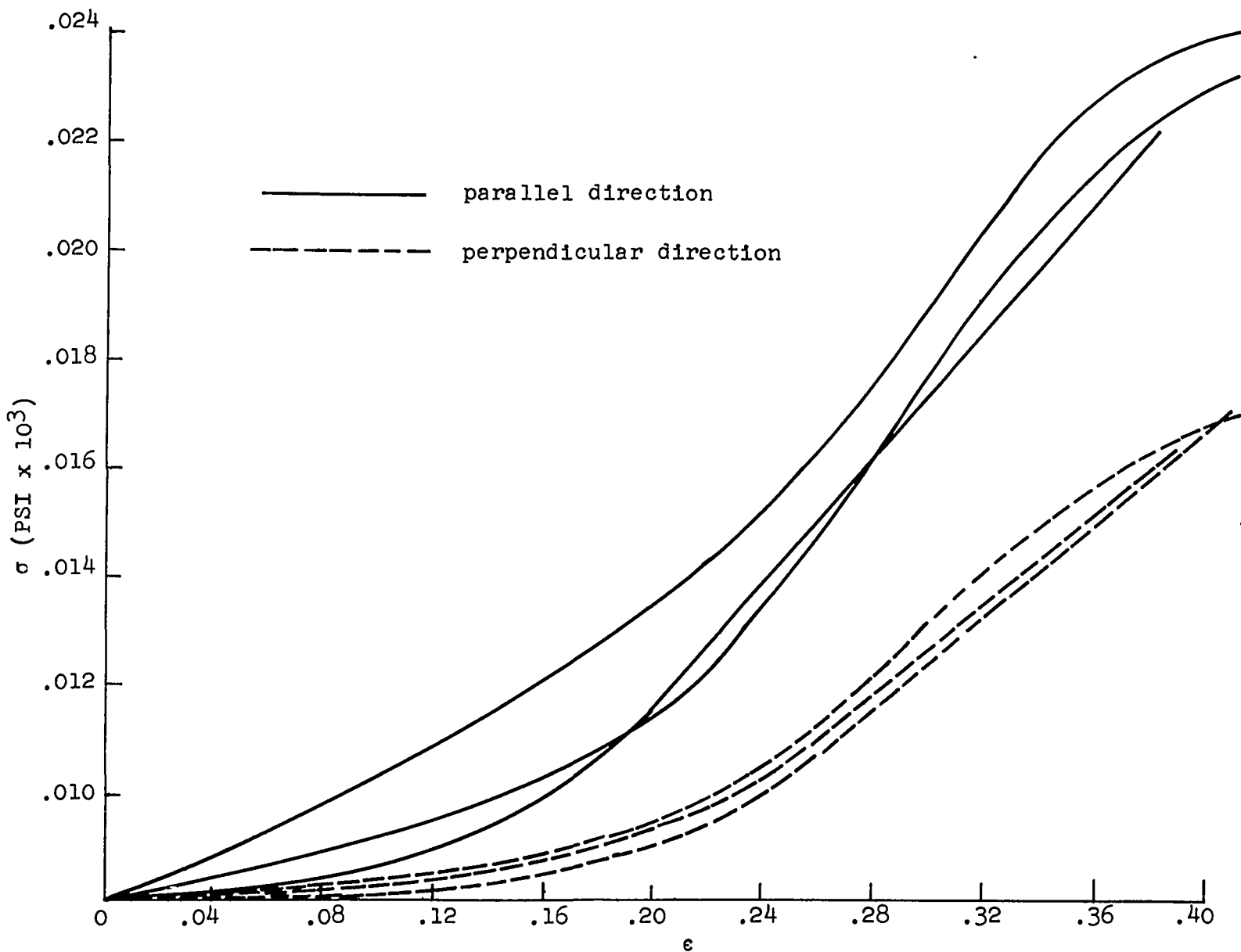
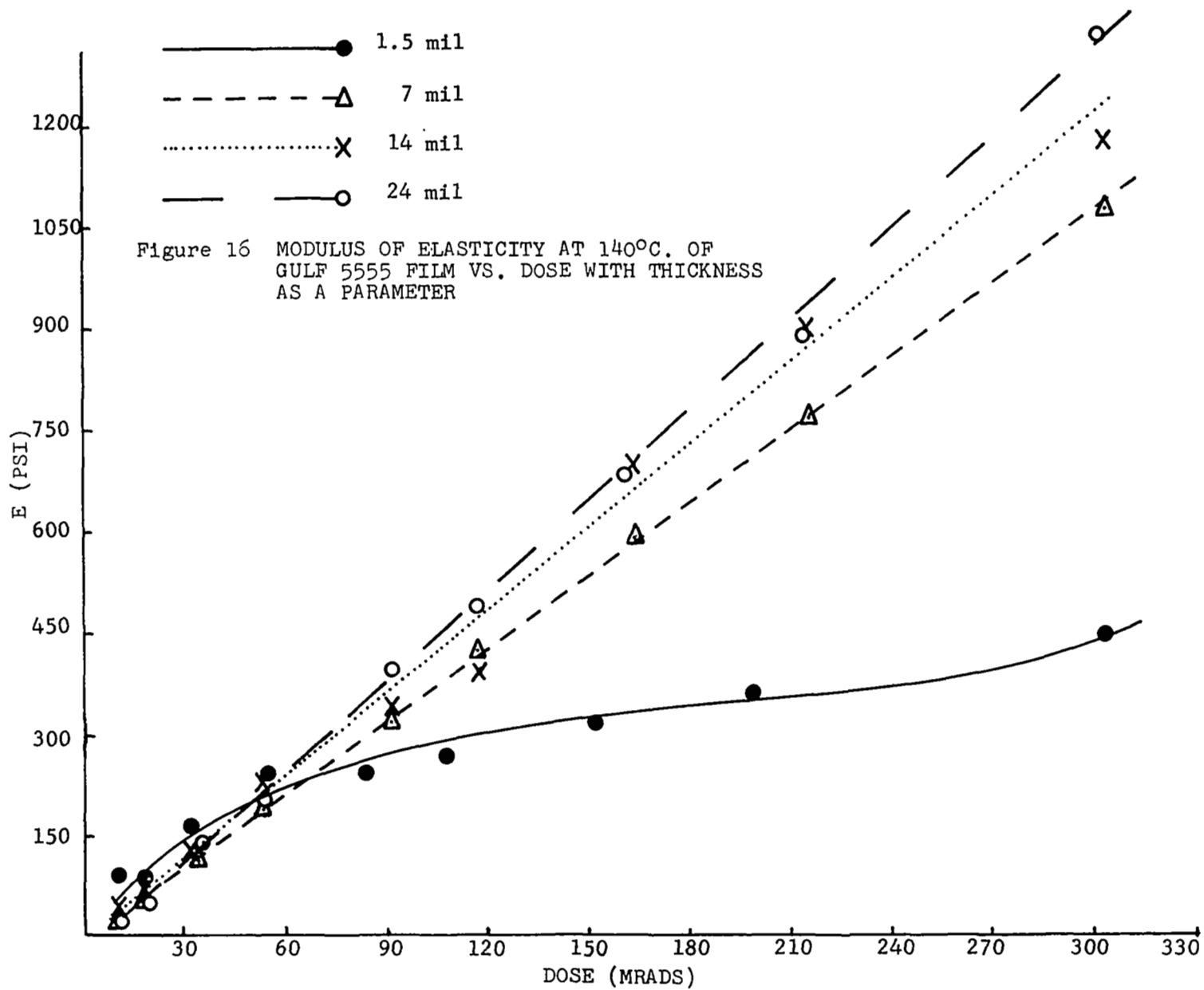

Figure 15 STRESS-STRAIN CURVES FOR CROSSLINKED GULF 5555 1.5 MIL POLYETHYLENE FILM AT 140°C.



due to the different conditions of processing different thickness films. This would be reflected in the equation relating the modulus to the molecular properties of the material - Eq. (1) on page 8. In Eq. (1) $\langle \alpha \rangle$, the linear dialation factor, reflects the effect of processing on the material and as discussed in Section 2.1 it may vary with processing.

Another possible cause of the increase in modulus with thickness at constant dose is from thermal and degradation effects. Crosslinking efficiency (for polyethylene) has been shown to increase with temperature in Section 2.1. Consequently, the thicker specimens which will more readily retain heat may have crosslinked more efficiently at the same dose level.

The most probable cause of this drop in modulus, however, is as follows. It has been shown that the presence of oxygen during irradiation* increases with scission to crosslinking ratio $\left(\frac{p_o}{q_o} \right)$. The increase in scission is due to oxygen diffusing into the film during irradiation. This diffusional effect is thickness dependent - being more pronounced for thin films. Consequently, the lower modulus of the thinner films may be reflecting the increased scission due to the oxygen diffusing into the film during irradiation. This may well be the case since the 1.5 mil

* All specimens irradiated during the program were done in an atmosphere purged with nitrogen to reduce the oxygen content.

film with the highest surface to volume ratio is found to be weakest. This would lower the number of crosslinks, hence, lower the positive effect of dose on the thinner films.

It should be pointed out that those linear modulus curves which were obtained are expected from theory. M_c , the molecular weight between crosslinks is given by Eq. (3). It is additionally known that the crosslink density q is directly proportional to the radiation dose (r), Eq. (2). If equations (2) and (3) are substituted into Eq. (1), the following linear expression relating modulus to dose is obtained.

$$E = \frac{3NkT_p \langle \alpha \rangle^2 g}{M_c} q_0 \left(r - \frac{M_c}{q_0 M_n} \right) \quad (14)$$

Furthermore, it is seen from Eq. (14) that there is a threshold dose equal to $\frac{M_c}{q_0 M_n}$ that must be exceeded before sufficient crosslinking takes place to obtain a crosslinked matrix to give the polymer enough mechanical integrity to yield an observable modulus. This, too, is experimentally observed where it is seen in Figure 16 that the modulus is 0 up to a dose of ca. 8 Mrads.

4.1.4 Modulus-Temperature Study

The modulus of elasticity of 1.5 mil Gulf 5555 film was measured through the temperature range -70°C . to 175°C . Below the T_m the polyethylene behaves essentially the same way as any ordinary semicrystalline polymeric

material. Non-crosslinked polyethylene was used here since the crystalline forces overwhelmingly predominate the crosslink forces below the T_m - consequently rendering the tensile of any level of crosslinked material essentially the same as non-crosslinked material.¹⁹ The modulus above the T_m should theoretically vary with dose and temperature as given by Eq. (14), as has been found in the previous section. Hence, different modulus-dose curves are needed above the T_m for each dose. The moduli determined in the temperature range investigated are listed in Table 6 and plotted in Figure 17. Since the modulus varies with dose as well as temperature above the T_m , the 85-91 Mrad dose level was chosen to be varied with temperature above the T_m as a representative dose. To gain an approximation on the upper and lower limits of the modulus above the T_m , the modulus curves at 13 Mrads and 300 Mrads have been plotted approximately by using the contour of the 85-91 Mrad curve and obtaining the levels of the curves by plotting the actual single values of E at 13 Mrads and 300 Mrads.

4.2 Shrinkage Properties and Equilibrium States of 1.5 Mil Gulf 5555 Polyethylene Film

4.2.1 Equilibrium Lengths

As discussed in Section 2.3 of the theory, there are three lengths to contend with in dealing with cross-linked oriented polymers. The first length (L_I) is the initial length - the length the material initially has when

Table 6

Modulus of Elasticity vs. Temperature for Gulf 5555
in Extrusion and Transverse Directions

T (°C)	Dose (Mrad)	E// (psix103)	E/ (psix103)
-70±2	0	76.5±19.2	73.0±20.2
-30±2	0	40.3±10.4	41.5±8.9
25±3	0	31.0±1.0	48.0±11.0
110±3	0	2.39±0.78	2.54±0.57
110±3	13	1.47±0.24	2.11±0.54
110±3	214.5	3.32±0.22	4.23±0.05
130±3	91	.284±.027	0.255±.162
140±3	13	.084±.006	0.016±.002
140±3	85	0.230±.009	0.213±.015
140±3	297	0.441±.003	-
175±3	91	0.187±.041	0.189±.128

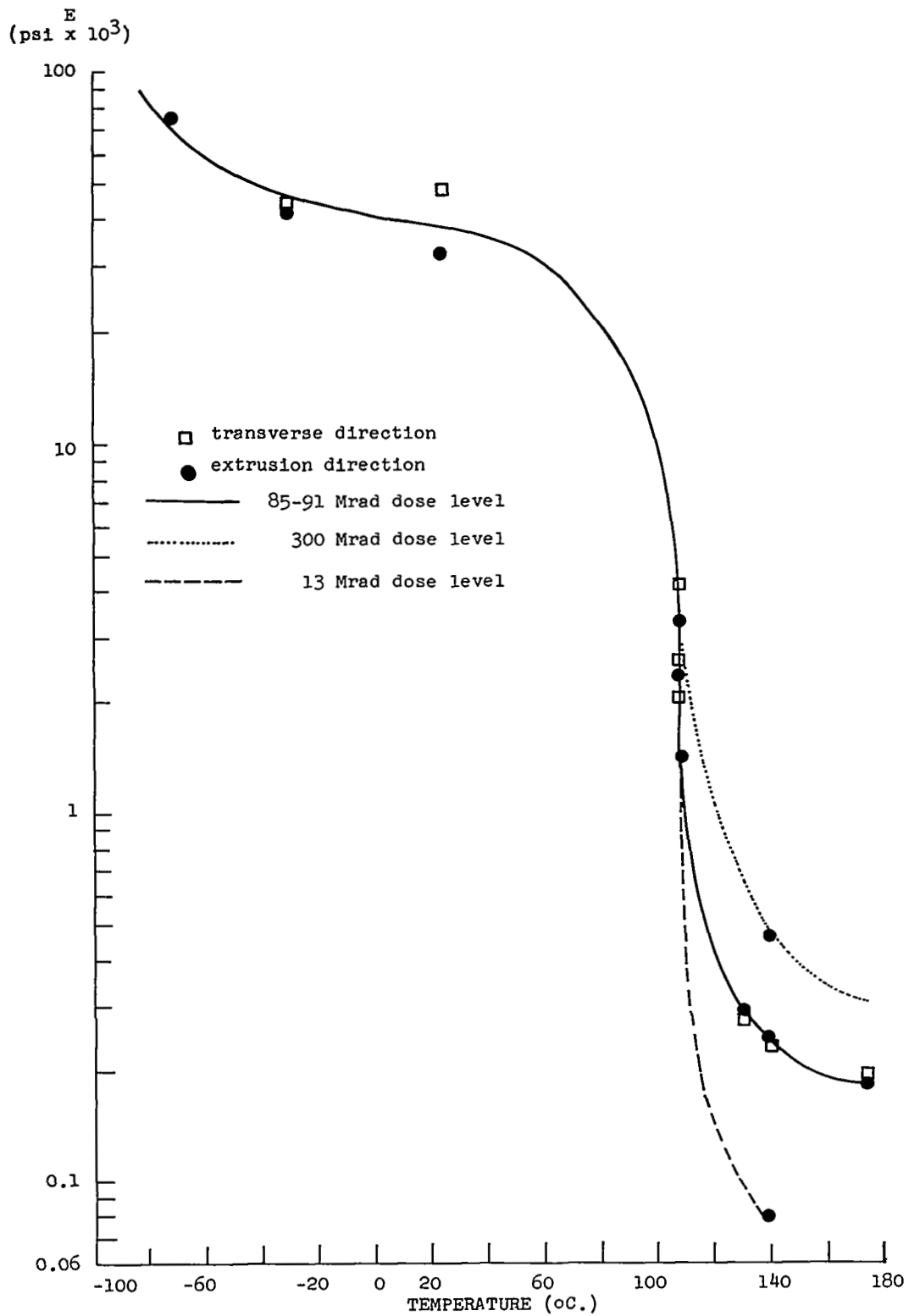

Figure 17 MODULUS OF ELASTICITY VS. TEMPERATURE FOR 1.5 MIL GULF 5555 POLYETHYLENE FILM

irradiated. It is not an equilibrium length since it shrinks upon heating and does not restore to its original length when cooled. The material does shrink to a hot length (L_{II}), called the isotropic length, which is in equilibrium with a new cold length (L_{III}).

As part of characterizing oriented crosslinked film, the dimensional changes in going from States I to II, and II to III, have been determined in the extrusion direction as a function of dose. The isotropic length (L_{II}) was determined by measuring the length of a sample at 140°C., with the original cold length being 1 in. to 1.5 in. Additionally, the new crystalline equilibrium length was measured at room temperature. Both equilibrium states are reported in Table 7 as fractions of L_I . Since the film is a biaxially oriented material to start with, it is likely that there should be dimensional changes upon going above the T_m in the transverse direction as well as the extrusion direction. It has been found, in a limited number of tests, that in the transverse direction there is a slight expansion in going from State III to II or I to III:

Mrad	L_{II}/L_{III}	L_{III}/L_I
58	$1.01 \pm .005$	$1.03 \pm .005$
85	$1.02 \pm .02$	$1.03 \pm .005$

4.2.2 Crystallinity

In order to fully characterize the polyethylene film in State III it was necessary to measure its percent crystallinity with time. Polyethylene, unlike most other polymers, approaches its final crystalline state by a

Table 7

Lengths Relative to Unheated State of 1.5 Mil
Gulf 5555 Film in Extrusion Direction
in Hot and Cold States vs. Dose

Dose (Mrad)	Lengths at 140°C.	Lengths at 23°C.
	L_{II}/L_I	L_{III}/L_I
11	0.795	0.59
18	0.800	-
30	0.823	0.78
54	0.857	0.87
85	0.883	0.89
106	0.916	-
110	-	0.89
150	-	0.83
200	0.962	0.94
297	0.953	-

secondary crystallization mechanism.²⁰ An important characteristic of a secondary crystallization mechanism is the long protracted time it takes for the polymer to achieve its final (equilibrium) crystalline state. What occurs is that the polyethylene first rapidly (< 10 min.) crystallizes to a given percent crystallinity by a primary crystallization mechanism; then there is a change of mechanism (to secondary crystallization) where the crystallization then proceeds at a more protracted pace (> 100 hr.). Current theory suggests that the primary crystallization consists of a combined nucleation and growth mechanism where the degree of crystallinity can be followed by the equation

$$\lambda = 1 - \exp(-zt^n) \quad (15)$$

where z is a rate constant

n is a constant from 1 to 4 depending on the type of nucleation and growth mechanism involved

t is the elapsed time

At the end of the primary crystallization the polyethylene is said to consist of nearly all crystals - but these crystals are of an imperfect form. There is poor chain packing at the outer portions of the crystal and there is poor packing between crystals. In general, there may be said to be amorphous regions within a given crystal. The mechanism of secondary crystallization then takes over to increase the perfection of the crystals by small molecular rearrangements in a nearly immobile matrix - hence, the slow rate. The crystallinity-time relationship during

secondary crystallization has been empirically found to have the following form.²⁰

$$\lambda = C + D \ln (t-t_0) \quad (16)$$

where C and D are constants

t_0 is the time of inception of secondary crystallization
t is the time of observation

To determine if any of the residual effects are of significance, long term density, crystallinity, and strength measurements were made on crosslinked Gulf 5555, 1.5 mil film irradiated to 90 Mrads and then annealed. Density was determined using a standard density gradient column^{29,30,31} consisting of a gradient of n-propanol and water operating at $23^{0\pm}0.1^{\circ}\text{C}$. The percent crystallinity was determined by infrared spectra from characteristic amorphous and crystalline absorption bands exhibited by polyethylene (see Appendix II), and the strength was determined by a standard Instron tensile test at ambient temperature.

It was found that there were slight increases in density, crystallinity and strength upon testing up to 700 hrs. (see Table 8). Significant I-R absorption bands showed changes (see Appendix III, Figures 26 through 33), that calculated to an approximate 6% increase in percent crystallinity. Strength increased by 25%, and density increased by about 4%. These results indicate that State III (i.e., annealed) material changes slightly with time and consequently may have to be further examined if the memory material is used in a situation that requires

Table 8

Changes of Properties with Time of Annealed (State III)
Crosslinked Gulf 5555 1.5 Mil Polyethylene Film

Time (hr.)	ρ (gm./cc.)	E// (psi)	E/ (psi)	Wave No.: 1303 cm. ⁻¹		1352 cm. ⁻¹		1368 cm. ⁻¹		$\bar{\lambda}$
				OD	λ	OD	λ	OD	λ	
0.14				0.064	0.514	0.079	0.459	0.115	0.468	0.480
0.31				0.063	0.522	0.079	0.459	0.119	0.449	0.476
0.41		13.8	15.6							
0.60				0.044	0.666	0.074	0.493	0.106	0.510	0.556
0.71	0.9185									
0.81	0.9188									
0.86				0.048	0.636	0.08	0.452	0.106	0.510	0.532
0.89	0.9188									
1.87	0.9193			0.056	0.575	0.106	0.274	0.115	0.468	0.439
3.57	0.9195									
5.5	0.9197	15.9	15.7							
5.86	0.9200									
23	0.9202									
24.6	0.9203	16.2	20.7	0.050	0.620	0.091	0.376	0.115	0.468	0.488
25	0.9204									
55	0.9206									
101	0.9206	18.7	16.6	0.047	0.643	0.071	0.514	0.096	0.556	0.571
389	0.9213	17.0	20.7	0.049	0.628	0.074	0.493	0.106	0.510	0.544
700	0.9220	19.7	18.5	0.048	0.636	0.072	0.507	0.105	0.514	0.552

close tolerances.

4.3 Environmental Tests

A number of environmental tests were performed on the crosslinked Gulf 5555 material. The tests were as follows:

- Modulus hysteresis
- Memory hysteresis
- Thermal shock
- Thermal degradation
- Blocking

In general, the results of the tests were successful with no appreciable loss of mechanical properties or memory on the first four tests. The only test that showed failure was the blocking test. Here, the polyethylene at all levels of crosslinking showed blocking.

A brief description of the tests and results now follow:

Modulus Hysteresis - An ordinary tensile test at 140°C. was run on a crosslinked sample a minimum of five times; that is, the sample was stretched passed its linear portion on the stress-strain-curve, relaxed to 0-strain, and rerun. It was found that there was a less than 2% loss in modulus with cycle, which is within the experimental error.

Memory Hysteresis - A limited number of cross-linked samples were subjected to the memory tests (described in Section 3.2.4) a minimum of five times. It was found that 100% recovery was obtained every time.

Thermal Shock - Samples of 1.5 mil Gulf 5555

polyethylene film at doses varying from 12 to 106 Mrads were cycled from boiling water (100°C.) to liquid nitrogen (-196°C.) twenty-five times. The samples were tested for degradation by measuring the modulus at 140°C. before and after the test and then comparing. It was found that there was considerable degradation at the 30 Mrad doses and below but at the higher doses, 58 Mrads and above, the loss in modulus was less than 15%. Additionally, memory tests were performed. It was found, in general, that 100% restoration was attained after this severe environmental test; although some slight curling and warping occurred in the 12 Mrad range.

Thermal Degradation - A limited number of cross-linked samples were placed in a vacuum oven at 175°C. for 4 hrs. Hot modulus and memory tests were performed before and after being subjected to the 175°C. temperature conditions. It was found that there was no loss in memory and a less than 10% loss in modulus after the exposure.

Blocking - Crosslinked samples of Gulf 5555, 1-5 mil film at doses of 13, 117 and 162 Mrads were placed together so that a peel test could be performed.

See diagram below.

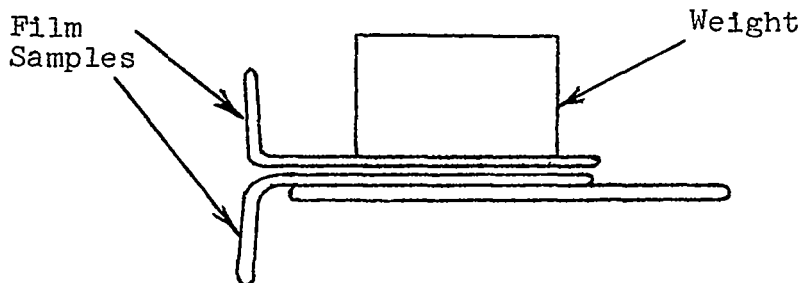

A weight was placed over the samples and the system was heated to 140°C. for 1 hour. The free ends were then pulled apart at 140°C. using the Instron tensile tester. It was found that blocking (i.e., sticking or self-bonding) occurred at all levels of crosslinking. The degree of blocking of the materials as classified by the Federal Test Method 1131 was as follows:

117 and 162 Mrads - Degree Sl. B. - Slight blocking. Sheets do not slide freely, but can be made to slide by application of slight force.

13 Mrads - Degree B. - Blocking. Sheets have to be peeled apart and surfaces are damaged.

5.0 BUCKLING PRESSURE THICKNESS STUDY

Since a major application for the plastic memory effect would be for the deployment of spherical satellites such as air density spheres, environmental detection spheres, and passive communications satellites, an analysis of the thickness required to withstand solar pressures for spheres of varying radii and strengths was performed. The effect of temperature on the required thickness was additionally investigated.

The classical equation derived for determining the critical buckling pressure as a function of thickness, t , of a thin spherical shell is given as follows:^{21, 22}

$$P_{cr} = \frac{2Et}{R(1-\nu^2)} \left[\left(\frac{1-\nu^2}{3} \right)^{\frac{1}{2}} \frac{t}{R} - \frac{\nu}{2} \frac{t^2}{R^2} \right] \quad (17)$$

where E = the modulus of elasticity
 ν = the Poisson's ratio
 R = Radius of sphere

For a large sphere with a thin shell

$$\frac{t^2}{R^2} \rightarrow 0$$

So equation (17) may be simplified as follows:

$$P_{cr} = \frac{2Et^2}{R^2 3^{\frac{1}{2}}(1-\nu^2)^{\frac{1}{2}}} \quad (18)$$

or

$$t = 3^{\frac{1}{4}}(1-\nu^2)^{\frac{1}{4}}R \left(\frac{P_{cr}}{2E} \right)^{\frac{1}{2}}$$

Equation (18) was used to calculate the skin thickness to withstand solar pressure of spheres of radii varying from 1 ft. to 4,000 ft. with modulus varying from 50 psi to 100,000 psi. The theoretical thickness values obtained are shown in Figure 18. Additionally, based on the modulus-temperature relationship found in Section 4.1.4 thickness temperature curves at constant radius have been developed which are shown in Figure 19. The dotted portions of the curves are in the phase transition region where large changes in strength occur for very small changes in temperature.

It has been found that the classical buckling pressure equation yields low values when the $\frac{t}{R}$ ratio is less than 10^{-3} . Summaries of the inaccuracy of using theoretical buckling pressure equations for thin shelled spheres are given in Theory of Elastic Stability and Formulas for Stress and Strain. They are, respectively, as follows:

"Experiments with thin spherical shells subjected to uniform external pressure show that buckling occurs at pressures much smaller than that given by equation (17)....."(ref. 23)

"Because of the greater likelihood of geometrical irregularities, and their greater relative effect, the critical stresses actually developed by such members usually fall short of the theoretical values by a wider margin than in the case of bars... The critical stresses or loads indicated by any one of the theoretical formulas should, therefore, be regarded as an upper limit, approached more or less closely according to the closeness with which the actual shape of the member approximate the geometrical form assumed...."

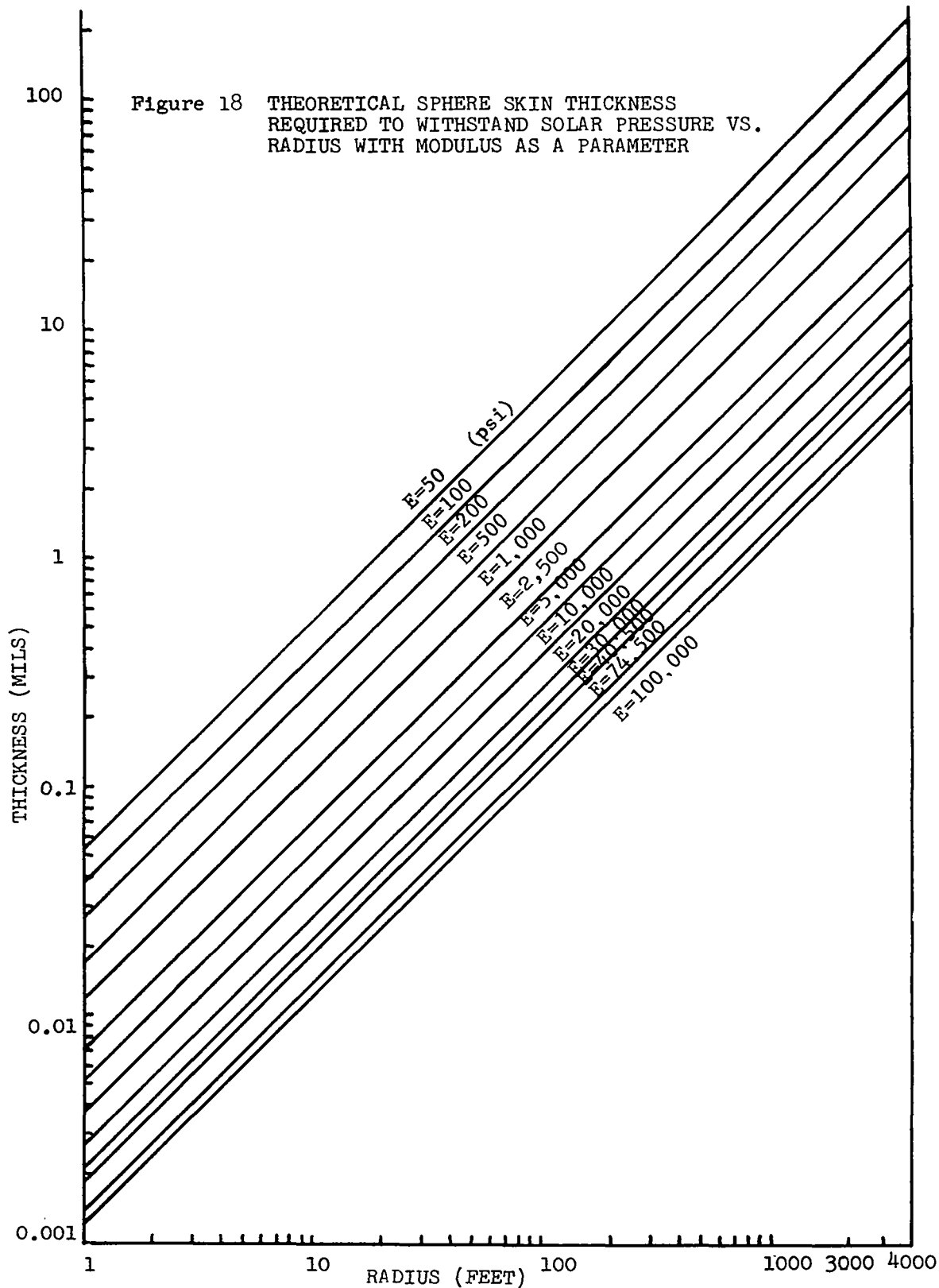
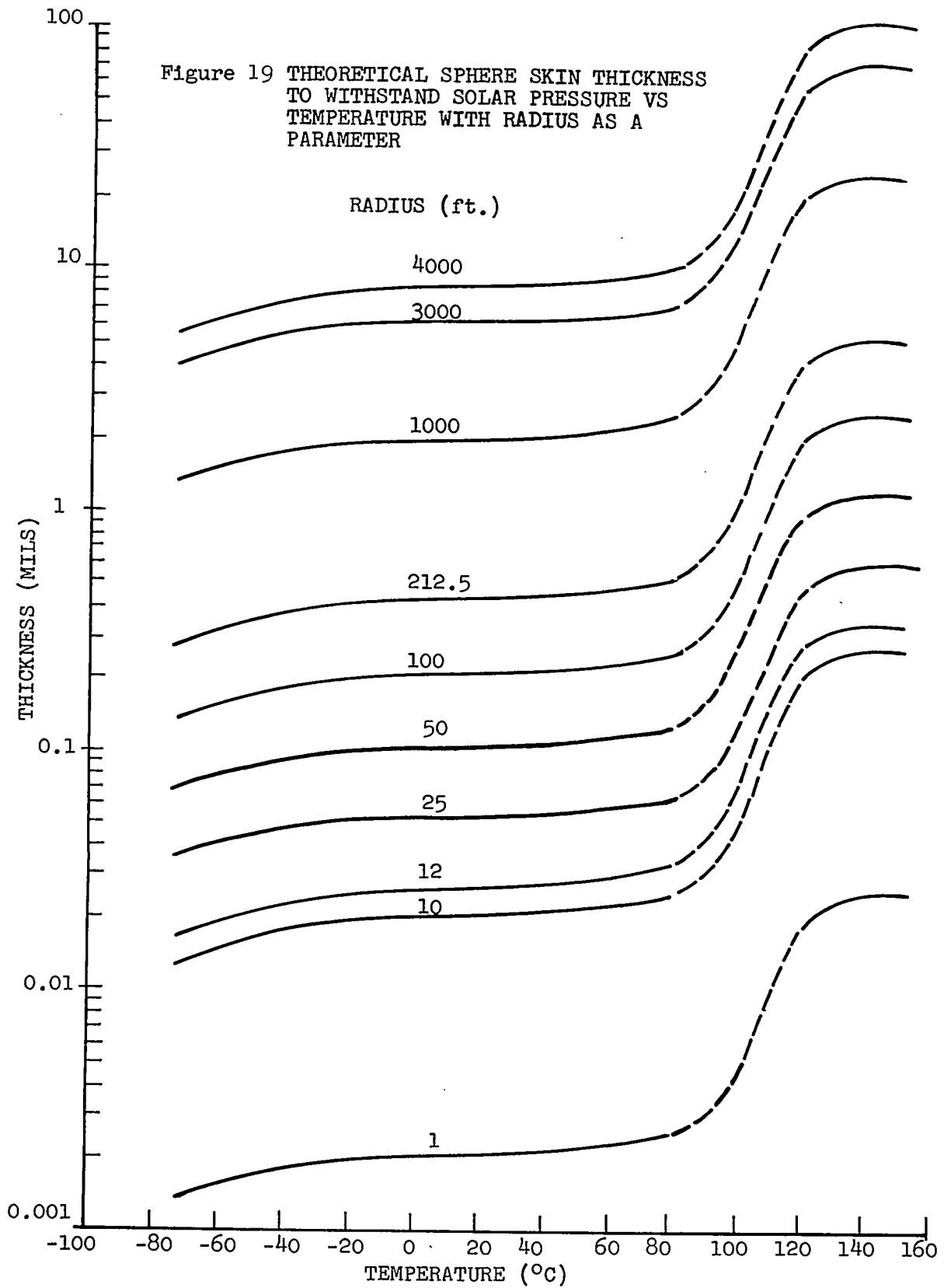

Figure 19 THEORETICAL SPHERE SKIN THICKNESS TO WITHSTAND SOLAR PRESSURE VS TEMPERATURE WITH RADIUS AS A PARAMETER



Rourk additionally states that this discrepancy continues to increase with the thinness of the material.²⁴

A limited number of buckling pressure tests were performed by NASA-Langley Research Center,²⁵ on thin walled spheres with $\frac{t}{R}$ values of 0.5882×10^{-4} and 0.1176×10^{-4} . The material used in these investigations was an aluminum mylar laminate of 0.71 mil total thickness (Echo II material), and the spheres investigated were 30 inches and 12.5 feet in diameter. It was found from these experiments that the actual pressure needed to cause buckling depended on the initial inflation pressure, and varied from 1/20 to 1/6 of the theoretical buckling pressure.

With the above considerations in mind, actual weights of spheres may be found by applying a correction factor \sqrt{k} to the thicknesses specified by radius and temperature. Following this method a sample calculation shows that a sphere of polyethylene memory material of .92 gm./cc. density is competitive with the Echo materials from a weight standpoint.

6.0 CONCLUSIONS AND RECOMMENDATIONS

The results obtained from this study have yielded sufficient information about the fundamental properties of crosslinked polyethylene memory material to determine the feasibility of its use for deploying objects in space. In addition, data on the mechanical properties has been gathered so that the memory material may be evaluated for structural purposes as well as for deployment purposes.

From studies on the fundamental properties of crosslinked polyethylene, Gulf 5555 polyethylene film was chosen to have its mechanical and memory properties evaluated in detail, since it most closely satisfied the acceptable criteria of a memory material.

The specific conclusions which follow indicate those areas completed and the specific accomplishments realized. Additionally, a listing of work still needed is given.

6.1 Crosslinking Properties

With the following factors affecting crosslinking evaluated, molecular weight, degree of branching, molecular weight distribution, crystallinity, temperature, dose, and crosslinking environment (presence of oxygen), it was found that molecular weight distribution is the predominating factor affecting crosslinking. In addition, the data compiled on crosslinking experimentally verifies the theory of crosslinking as discussed in Section 2.0.

6.2 Mechanical Properties

The mechanical properties of the crosslinked Gulf 5555 material were determined in detail. It was found, that the material has sufficient strength for the construction of satellites subjected to solar pressures. Additionally, it was found that the material can withstand a number of environmental tests such as thermal shock and thermal degradation tests.

6.3 Memory

The memory of a number of initial materials was investigated to determine the effect of their molecular properties. It was found, as in the crosslinking study, that the material with the narrowest molecular weight distribution (Gulf 5555) had the best memory.

Of most importance in the empirical experiments on demonstrating the memory effect was the fact that for the first time a crosslinked, thin film (1.0 mil) material was demonstrated to restore 100% (have a complete reversible memory) in a 1-g environment. This indicates that a cross-linked, thin film material should restore 100% in a 0-g environment. The memory of thin, crosslinked polyethylene film was also shown to be repeatable, that is, capable of restoring to its required configuration after many cycles.

6.4 Processing

It had been found that complete (100%) restoration of a memory material is dependent upon the state of strain (orientation) it is in when crosslinked. If the material

is oriented when crosslinked it will irreversibly shrink upon the first memory cycle. It had been found that two processes can be used to eliminate this problem. They are:

1. Producing stress-free films.
2. Annealing the crosslinked oriented film- and then using this annealed film as the starting material.

6.5 Uses

Based upon the strength of the crosslinked polyethylene at various doses and temperatures it was found that spheres of radius of up to 200 ft. could be constructed to withstand solar pressures when operating at temperatures between +60°C. and -70°C. and still not be prohibitive in weight. (Larger radii spheres could be constructed to operate at lower temperatures.) A sphere with a radius of 200 ft. would need a skin thickness of ca. 1.0 mil corresponding to a weight of 4,000 lbs. Of even greater interest is the fact that spheres of up to 100 ft. radius could be constructed to withstand solar pressures when operating at temperatures above the T_m and still not be prohibitive in weight. A sphere of 100 ft. radius operating at 140°C. would need a thickness of only 3.5 mils corresponding to a weight of 4,000 lbs. and a sphere of 6 ft. radius need only weigh 0.36 lbs.

The low weight characteristics of using polyethylene memory material as a medium for deployment (with no inflatant) strongly suggests the use of the material for air density spheres, environmental detection spheres

as well as passive communications satellites and reflectors.

Although most of the attention in using the memory effect in this and past work is directed towards the construction of balloon-like objects made from film material, the memory concept is not entirely limited to these configurations. A natural area, where the memory effect can be used as a means of deployment, is in the deployment of flat and cornered objects where inflatable deployment techniques cannot be used. In this case the memory effect can be used to deploy objects such as corner reflectors, I-beams and other structural units. Another configuration of possible use is highly oriented polyethylene fiber. It has been found that highly oriented, highly crosslinked (above ca. 500 Mrads) polyethylene fiber is capable of self-contraction and self-expansion when taken respectively above or below the T_m .^{17,18} The expanded length of the fiber is approximately 25% longer than the contracted length and, as discussed in Section 2.3 of the Theory, after an initial annealing these two states are reversible (see schematic diagram, page 26). Consequently, the crosslinked, oriented polyethylene fiber coated with the proper thermal control coating can be used as the working medium in a reversible heat engine¹⁸ or used as a "passive" control mechanism that is thermally activated.

6.6 Future Work

Areas still not fully investigated that require study before the memory effect can become operative are as follows:

Thermal Control Coatings

An Annealing Scale-Up

Bonding

Blocking

The effect of metallic coatings on strength.

Two other areas which were lightly touched upon in this study, the effect of branching and oxygen environment on the efficiency of crosslinking, should be undertaken to see if the dose can be sufficiently lowered to achieve the same level of crosslinking.

Thermal Control Coatings - Metallized Surfaces -

The utilization of the memory phenomenon is wholly dependent on the application of heat to the packaged article. The heat input must raise the temperature of the structure (above its T_m) to be deployed. As noted previously, the restoration forces can only operate once the crystalline restraining forces are removed. Therefore, step one in any deployment scheme requires heating the structure above its T_m . Since the predominant source of heat in space is by radiative absorption it necessitates control of the surface's α/ϵ ratio to obtain a temperature $T_{eq} > T_m$. Along with achieving $T_{eq} > T_m$ it may be necessary to have the surface coating of specific smoothness depending upon its use.

An Annealing Scale-Up - Since it is important to obtain a material that does not irreversibly shrink upon going through a memory cycle, it is necessary to obtain a shrink-free material (such as a cast, pressed or molded material) or to modify a shrinkable material (extruded film) to remove the shrinkage by annealing. It has already been shown that stress-free materials are suitable as the starting material to be used as the medium for a memory cycle. Additionally, it has been shown for crosslinked films that are oriented, an annealing step above the T_m will yield a material which will have states which are reversible between temperatures below and above the T_m . The next step would then involve using this data on annealing developed under this contract to scale up the operation of annealing to produce quantities of materials.

Bonding - At present it has been established that an excellent bond is produced by ultrasonic bonding techniques on polyethylene crosslinked to 15 Mrads.²⁶ But it is also important to study the variation on bond strength and ease of bonding with the degree of crosslinking. It has been shown that the memory force increases with an increase in radiation dose. This increase in dose causes the development of a tighter crosslinked network. The flow properties of the crosslinked plastic decrease as the crosslink density increases and this in turn adversely affects the ease of bonding and bond strength

since ultrasonic bonding involves only the surface flow of two interfaces.

The bond strength of the polyethylene at various degrees of crosslinking may probably be the governing factor in specifying the permissible crosslinking density. It would be desirable to use the highest possible crosslink density since this maximizes the restoration force. The operating variables of ultrasonic and other bonding techniques should be studied to achieve satisfactory bonds at high degrees of crosslinking.

Blocking - If a polyethylene memory structure is to be used unmetallized or metallized on one side, blocking will present a problem. In the absence of metallic coatings it is then necessary to run experimental studies on the adhesion and blocking retarding characteristics of organic coatings on the crosslinked polyethylene.

Effect of Metallic Coating on Memory and Strength - In conjunction with the application of metallized surfaces a study needs to be undertaken to determine the effects on the memory of the crosslinked polyethylene film by the applied metallic coating to the film. This needs to be done since it is possible that too thick a metallic coating relative to the crosslinked polyethylene could retard the memory of the crosslinked polyethylene film.

Since added metal coating will increase the strength of a polyethylene film material over that of the polyethylene alone, it would be necessary to determine the

strength of the laminate for its use in any structural application.

Test Models - As a final step of the research described and recommended herein, it is strongly suggested that small, thin spherical models be constructed to be used in 0-g deployment tests. This would give strong proof of the feasibility of the memory effect with its many interacting parameters and set the stage for its use in deploying items for actual tasks.

REFERENCES

1. Charlesby, A., "Atomic Radiation and Polymers," Pergamon Press, London (1960).
2. Bueche, F., "Physical Properties of Polymers," Chapter III, John Wiley & Sons, New York (1962).
3. Flory, P.J., "Theory of Elastic Mechanisms in Fibrous Proteins," Journal of the American Chemical Society, Vol. 78, pp. 5222-5233 (1956).
4. Chapiro, A., "Radiation Chemistry of Polymeric Systems," pp. 388, 441, Interscience Publishers (1962).
5. Bovey, F.A., "The Effects of Ionizing Radiation on Natural and Synthetic High Polymers," pp. 49-55, 106-113, Interscience Publishers, New York (1958).
6. Kang, H.Y., O. Saito, and M. Dole, Journal of the American Chemical Society, 89, 1980 (1967).
7. Dole, M., C.D. Kellig and D.G. Rose, Journal of the American Chemical Society, Vol. 76, p. 4304 (1954).
8. Weiss, Journal of Polymer Science, 29, 425 (1958).
9. Libby, W.F., Journal of Chemical Physics, 35, 1714 (1961).
10. Stocklin, G. and A.P. Wolf, Journal of the American Chemical Society, 85, 229 (1963).
11. Saito, O., H.Y. Kang, and M. Dole, "Theory of Gel-Dose Curves for Polymers Undergoing Simultaneous Crosslinking and Scission," to be published in JACS in 1968.
12. Kitaman, R., L. Mandelkern, and J. Fatou, Journal of Polymer Science, 2, 5B, 511 (1964).
13. Kitaman, R., L. Mandelkern, Journal of the American Chemical Society, 86, 17, 3529 (1964).
14. Kitaman, R., L. Mandelkern, Journal of Polymer Science, 2, 11, 1019 (1964).
15. Willbourn, A.H., Journal of Polymer Science, Vol. XXXIV, pp. 569-597 (1959).

16. Matsuo, H., M. Dole, Journal of the American Chemical Society, 837, June 1959.
17. Mandelkern, L., D.E. Roberts, A.F. Diorio and A.S. Posner, Journal of the American Chemical Society, Vol. 81, pp. 4148-4157 (1959).
18. Mandelkern, L., "Crystallization of Polymers," pp. 166-213, McGraw Hill, New York (1964).
19. Ibid., ref. 1, p. 239.
20. Sharples, A., "Introduction to Polymer Crystallization," Butterworth, London (1966).
21. Rourk, R.J., "Formulas for Stress and Strain," 3rd ed., p. 318.
22. Timoshenko, S., and Gere, "Theory of Elastic Stability," 2nd ed., pp. 512-519, "Buckling of Uniformly Compressed Spherical Shells".
23. Ibid. p. 518.
24. Ibid., ref. 21, p. 303.
25. Fichter, W., H.G. McComb, Jr., R.W. Leonard, "Buckling of the Echo A-12 Passive Communications Satellite," NASA TN D-2353, July 1964.
26. D'Agostino, V., P. Keusch, "Development of a Prototype Plastic Space Erectable Satellite," NASA CR 892, September 1967.
27. Inokuti, M., Journal of Chemical Physics, Vol. 38, 2999 (1963).
28. Wesslau, H., Makromol. Chem., Vol. 20, 111 (1956).
29. Oster, Gerald, M. Yamamoto, "Density Gradient Techniques," Chemical Reviews, Vol. 63, #3, pp. 257-268, June 1963.
30. ASTM D 1505-63T, ASTM Standards Plastics-Methods of Testing, Part 27, June 1965, pp. 500-506.
31. Wiley, Richard, E., "Setting up a Density Gradient Laboratory," Plastics Technology, March 1962.

32. Moore, J.C., "Gel Permeation Chromatography I. A New Method for Molecular Weight Distribution of High Polymers," *Journal of Polymer Sci.: Part A-2*, 835 (1964).
33. Moore, J.C., J.G. Hendrickson, *Journal of Polymer Sci.*, C233 (1965).
34. Salovey, R., and M.Y. Hellman, "Gel Permeation Chromatography of Branched Polyethylene," *Journal of Polymer Sci.: Part A-2*, Vol. 5, pp. 333-342 (1967).
35. Greff, R., "Gel Permeation Chromatography," *Polytechnic Institute of Brooklyn Polymer Seminar*, Vol. 17, No. 5, Dec. 1967.
36. Wild, L., and R. Guliana, "Gel Permeation Chromatography of Polyethylene: Effect of Long-Chain Branching," *U.S. Industrial Chemicals Co.*, private correspondence, 1967.
37. Miller, R.G.J., and H.A. Willis, "An Independent Measurement of the Amorphous Content of Polymers," *Journal of Polymer Sci.*, Vol. XIX, pp. 485-494 (1956).
38. Okada, T., and L. Mandelkern, "Effect of Morphology and Degree of Crystallinity on Infrared Absorption Spectra of Linear Polyethylene," *Journal of Polymer Sci.*, Part A-2, 5, 239-262 (1967).
39. *ibid.* ref. 20, p. 60.

8.0	<u>LIST OF SYMBOLS</u>
a	The cross-sectional area of a polymer molecule.
g	The gel fraction of a crosslinked polymer, dimensionless.
k	Boltzmann constant.
$k_a(T)$	Number of crosslinks per dose produced in the amorphous region of a polyethylene material.
$k_c(T)$	Number of crosslinks per dose produced in the crystalline region of a polyethylene material.
k_{a_n}	The specific extinction coefficient for the completely amorphous polymer at the wave number n, $\text{cm.}^2/\text{gm.}$
k_{c_n}	The specific extinction coefficient for the completely crystalline polymer at the wave number n, $\text{cm.}^2/\text{gm.}$
m	The slope of the Charlesby-Pinner curve, $s+\sqrt{s}$ vs. $\frac{1}{P}$, Mrads.
$m(P,0)$	The initial molecular size distribution.
n	An exponential constant for polymer crystallization; wave number in the infrared region, cm.^{-1} .
p_0	The fracture density per 1 Mrad of irradiation.
q	Crosslinking density.
q_0	Crosslinking density obtained per 1 Mrad irradiation.
r	Radiation dose, Mrads.
s	The sol fraction of a crosslinked polymer, dimensionless.
t	The elapsed time; sphere thickness, inches.
t_0	The time of inception of secondary crystallization.
v	Number of polymer chains per unit volume; number of crosslink units in the network structure; Poisson's ratio.
\bar{v}	Specific volume of polymer above its T_m .

LIST OF SYMBOLS (Continued)

y	The number of crosslinks per initial number average molecule.
z	A rate constant for polymer crystallization.
C	A constant for secondary crystallization.
D	A constant for secondary crystallization.
E	Modulus of Elasticity, psi.
I	The intensity after absorption.
I_0	Beam intensity.
L_i	The isotropic chain length.
L_0	The length of an uncrosslinked sample above its T_m .
L_R	Original length of sample.
M_c	Molecular Weight between crosslinks.
M_n	Number average molecular weight of polymer chain.
M_0	Molecular Weight of a repeat unit in a polymer chain.
M_w	Weight average molecular weight.
N	Avagadro's Number
OD	Optical density = $\ln \frac{I_0}{I}$,
OD_n	The optical density at the wave number, n.
P	The degree of polymerization.
P_{cr}	Critical buckling pressure, psi.
$P_n(0)$	The initial number average degree of polymerization.
Q	Total number of crosslinks per dose produced in a polyethylene material.
R	Radius of sphere, inches.
\bar{R}_0^2	Mean square end to end distance of an unconstrained polymer chain.

LIST OF SYMBOLS (Continued)

T	Absolute temperature, °K.
T _m	Crystalline melting point, °C.
<α>	The linear dialation factor = average chain length in the oriented state/average chain length in the unoriented state.
β	Parameter in the Wesslau molecular weight distribution expressing the spread of the distribution.
δ	The crosslinking coefficient. The number of crosslink units per weight average molecule.
ε	Strain, dimensionless; specific extinction coefficient, cm. ² /gm.
ε _a _n	The specific extinction coefficient for amorphous polyethylene at the wave number n, cm. ² /gm.
ε _c _n	The specific extinction coefficient for crystalline polyethylene at the wave number n, cm. ² /gm.
λ, λ(T)	Fraction of crystallinity in a polyethylene material, dimensionless.
ρ	Density, gm./cc.
σ	Stress, psi.
τ	The scission to crosslinking ratio.

APPENDIX I - GEL PERMEATION CHROMATOGRAPHY TO DETERMINE
MOLECULAR WEIGHT DISTRIBUTIONS

In completing the work on the initial properties of the films under study, gel permeation chromatographies (GPC) have been performed on the polymer films used in the memory study to determine the molecular weight distribution of the materials. The technique of gel permeation chromatography involves the elution and selective separation of a polymer dissolved in solvent through a column packed with a crosslinked polystyrene porous gel.³² The concentration of polymer leaving the column is measured by differential refractometry vs. time. A schematic diagram of the system is shown in Figure 20. The molecular separation in this system is determined by the sizes of the isolated molecules at the conditions of operation and the solvent used.^{32,33} The smaller molecules are more likely to become entangled in the crosslinked styrene gel than the larger ones. Hence, the larger molecules leave the column at a faster rate than the smaller ones. The technique requires the calibration, for a given column and operating conditions, of known molecular weight fractions of a given substance versus the time it takes for these different fractions to pass through the column. It must be emphasized that in using GPC to determine the molecular weight distribution of polymers that the conditions used must be exactly the same as those used to determine the calibration curve.^{34,35}

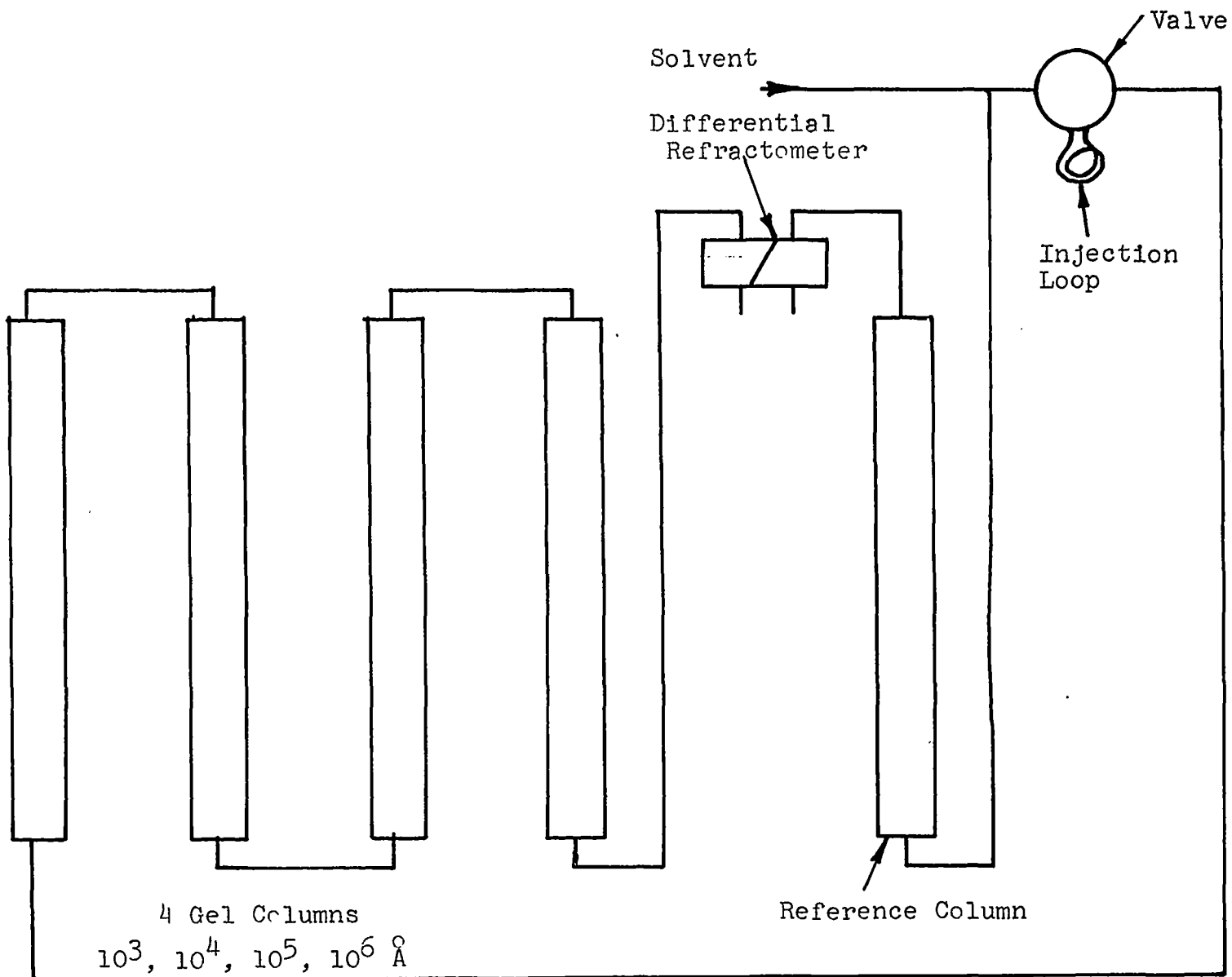

Figure 20 SIMPLIFIED SCHEMATIC DIAGRAM OF GPC APPARATUS

The conditions used to determine the molecular weight distribution of the polyethylenes under study are as follows:

Temperature: 138°C.

Solvent: 1,2,4-Trichlorobenzene

Concentration: 0.25% polymer solution

Flow rate: 1.0 ml./min.

Column Arrangement: Four columns in series,
permeability limits

10^6 , 10^5 , 10^4 , 10^3 Å.

Column material: Polystyrene gel.

Calibration curves (see Figure 21) at these conditions for both linear and branched polyethylenes are available.³⁶ The results of the gel permeation chromatographies are shown in Figures 22 through 25. The heights of these curves are a direct measure of the weight fractions at the corresponding counts. From the primary distribution curves (Figures 22 through 25) the average molecular weights have been computed using the following equations:

$$M_n = \frac{\sum h_i}{\sum \frac{h_i}{M_i}} \quad (19)$$

$$M_w = \frac{\sum h_i M_i}{\sum h_i} \quad (20)$$

where M_n = number average molecular weight

M_w = weight average molecular weight

M_i = number average molecular weight at a given count

h_i = height-concentration (GPC curve) at a given count.

Figure 21 GPC CALIBRATION CURVES

Analysis Conditions:
Solvent: 1,2,4-Trichlorobenzene
Columns: 10^6 , 10^5 , 10^4 , 10^3 Å
(in series)
Temperature: 138°C.
Flow rate: 1 cc./min.

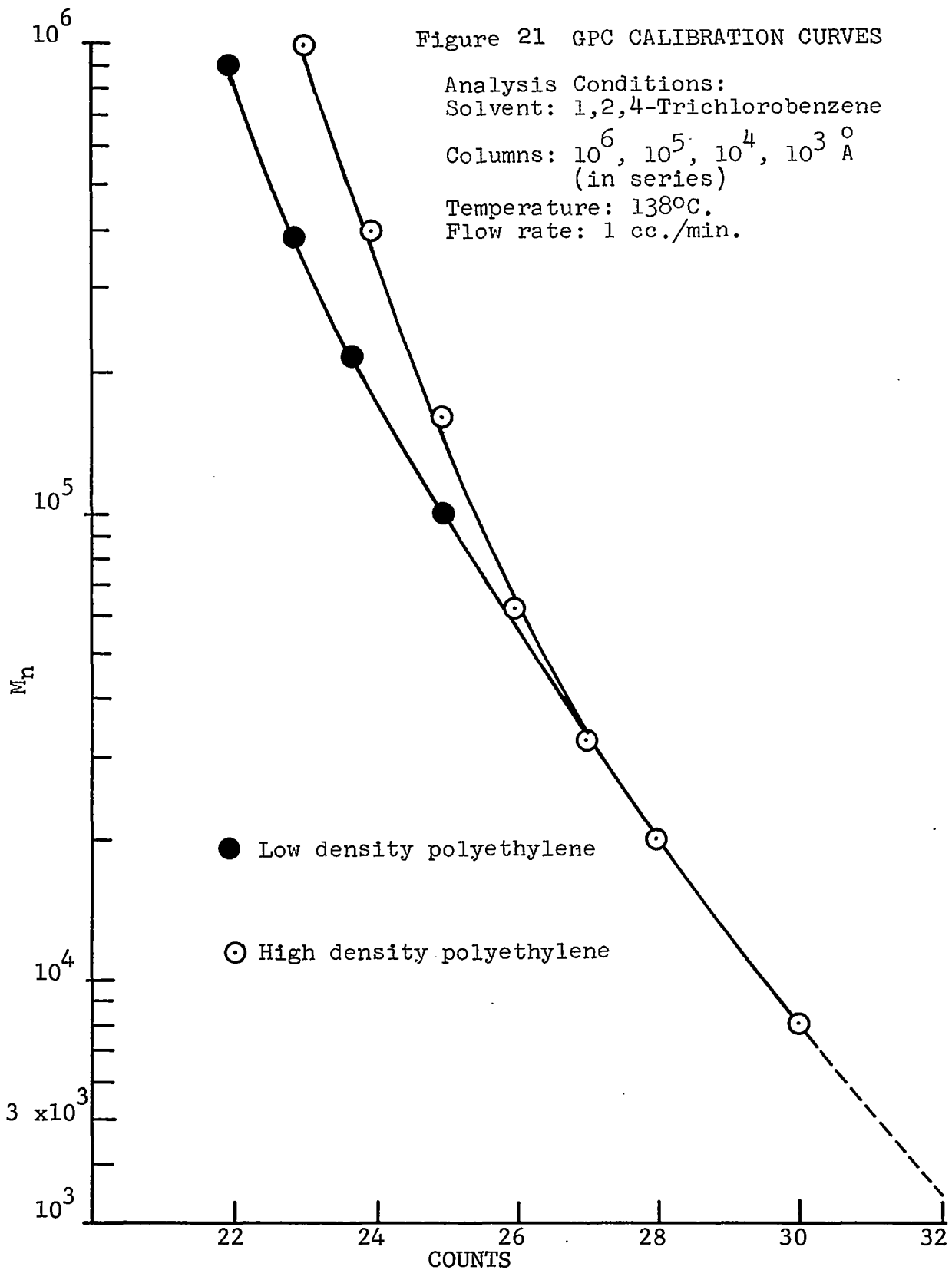

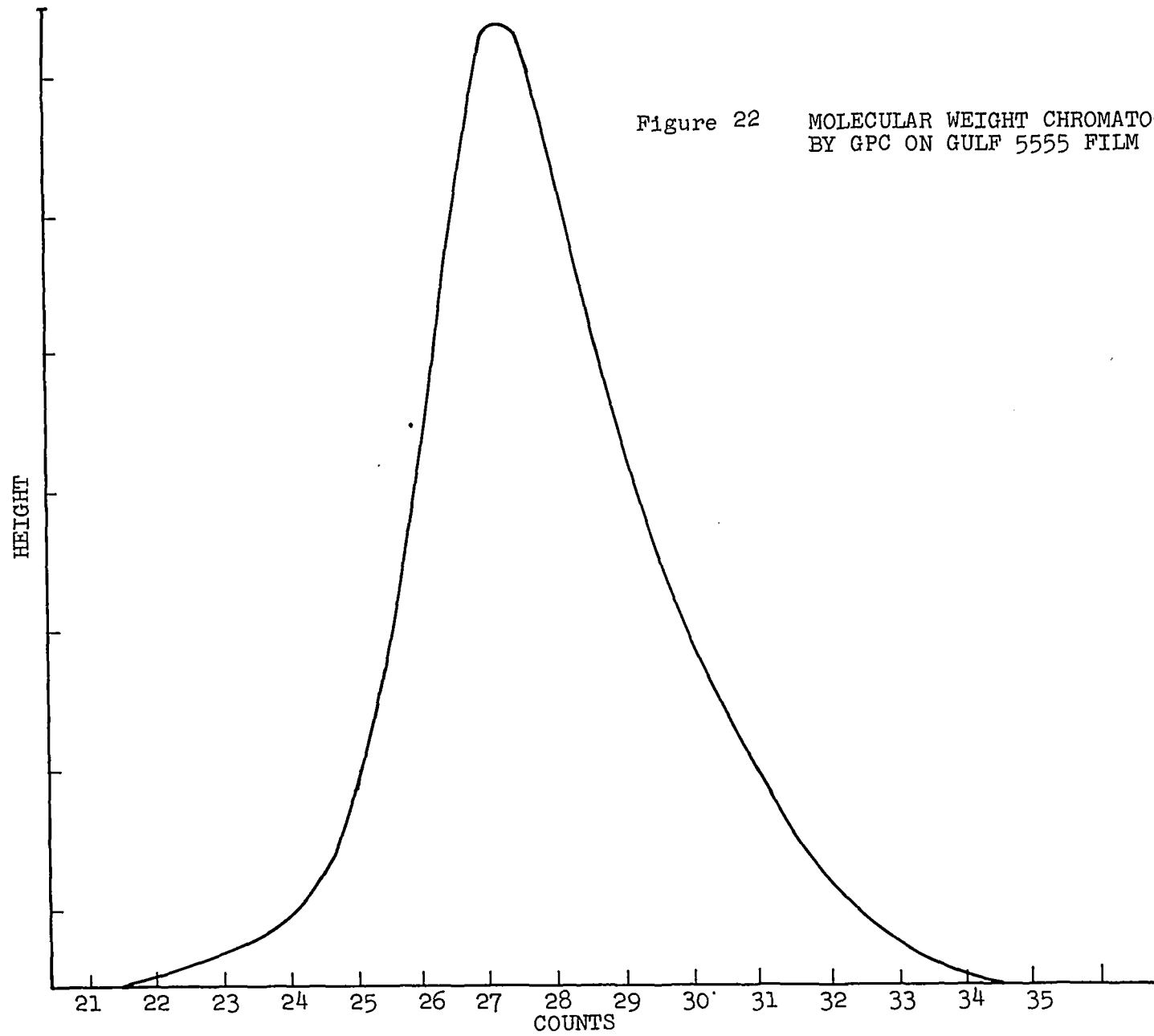

Figure 22 MOLECULAR WEIGHT CHROMATOGRAM
BY GPC ON GULF 5555 FILM

Figure 23 MOLECULAR WEIGHT CHROMATOGRAM BY GPC ON PHILLIPS 3328 FILM

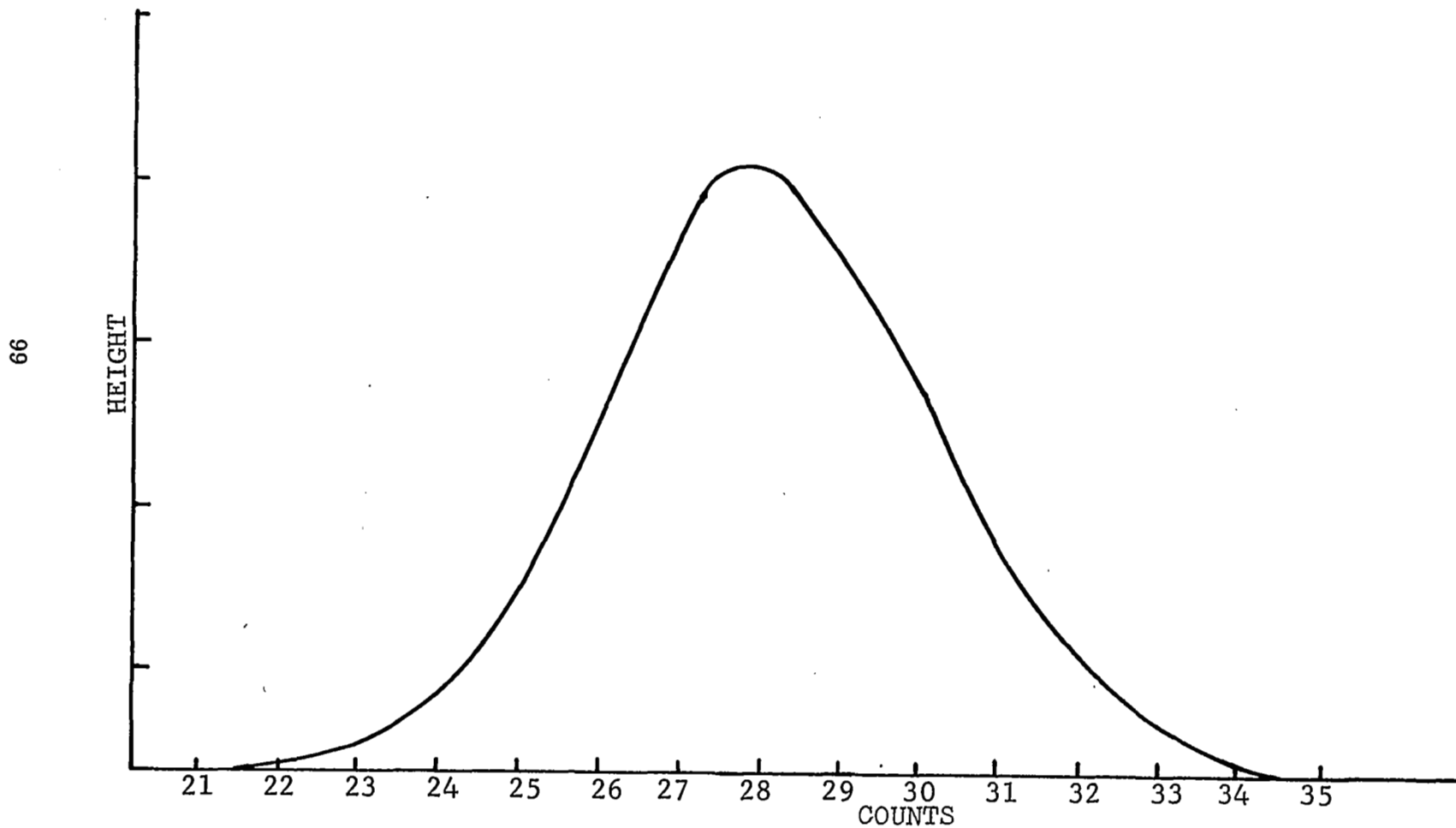

Figure 24 MOLECULAR WEIGHT CHROMATOGRAM BY GPC ON DUPONT SUPER C FILM

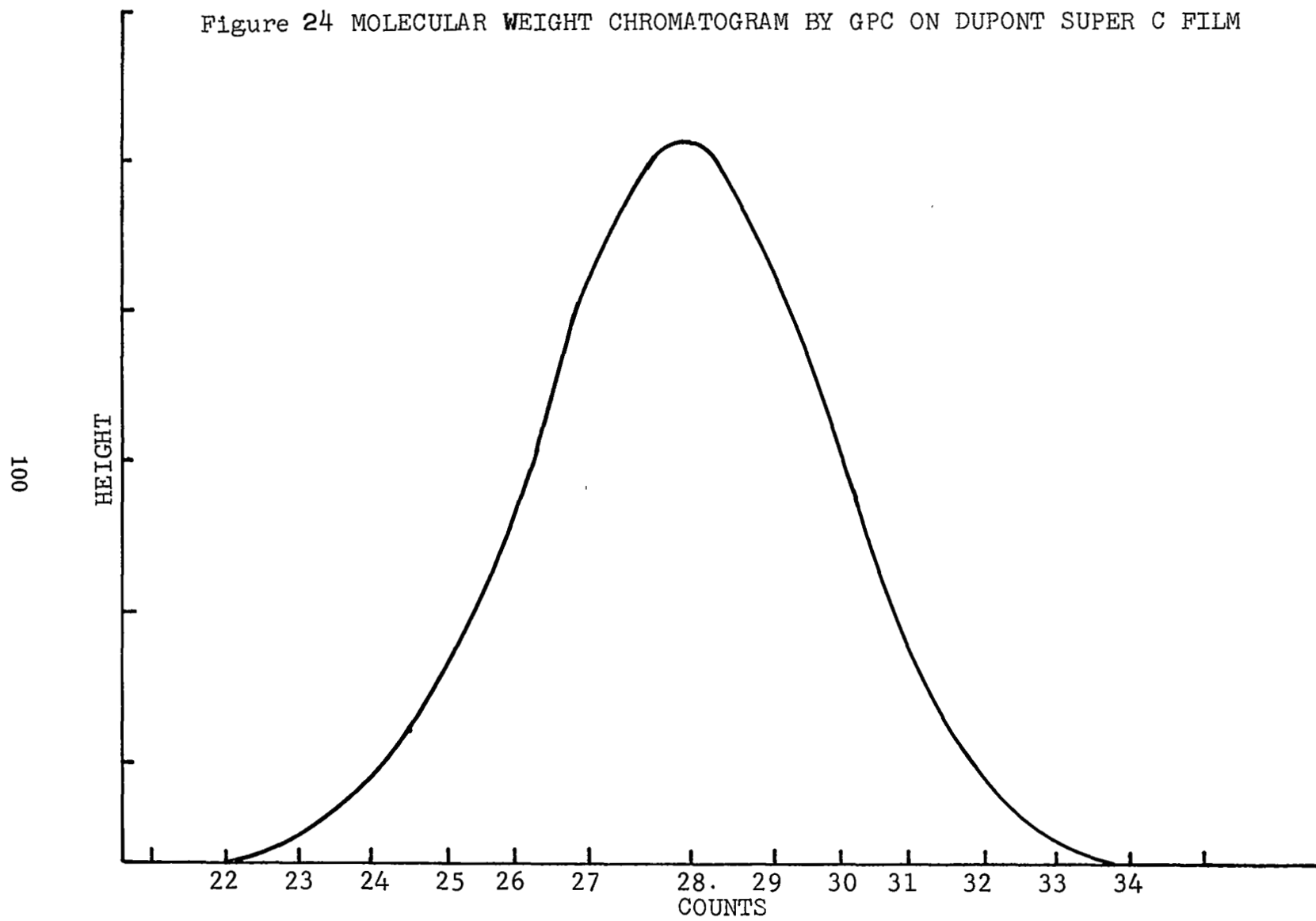
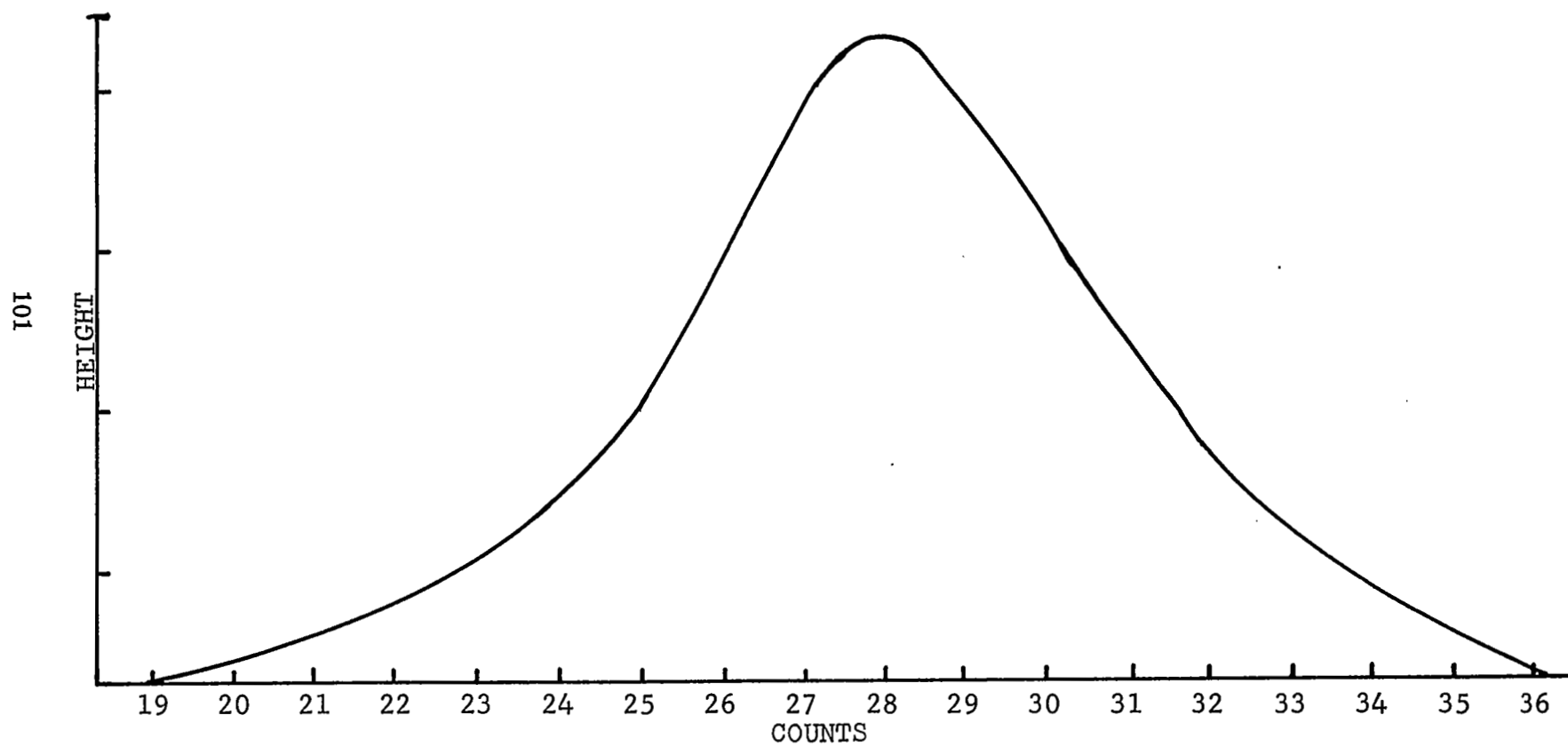

Figure 25 MOLECULAR WEIGHT CHROMATOGRAM BY GPC ON PHILLIPS 6003 FILM



APPENDIX II - THE DETERMINATION OF THE PERCENT CRYSTALLINITY OF POLYETHYLENE FILM BY INFRARED SPECTRA MEASUREMENT

The fraction crystallinity (λ) or fraction amorphous ($1-\lambda$) material can be determined by infrared spectra from characteristic amorphous or crystalline absorption bands exhibited by polyethylene. The following absorption bands are considered:^{37,38}

1303 cm. ⁻¹	amorphous
1352 cm. ⁻¹	amorphous
1368 cm. ⁻¹	amorphous
1894 cm. ⁻¹	crystalline

Use is made of Beers law:

$$\ln \frac{I_0}{I} = \epsilon t \rho \quad (21)$$

where I_0 = the beam intensity

I = the intensity after absorption

$\ln \frac{I_0}{I}$ = the optical density = OD

ϵ = the specific extinction coefficient

t = the sample thickness

ρ = the sample density

For an amorphous band the specific extinction coefficient is directly related to the fraction of amorphous material contained in the sample:

$$\epsilon_{a_n} = k_{a_n} (1-\lambda) \quad (22)$$

For a crystalline band the specific extinction coefficient is directly related to the fraction of crystalline material in the sample:

$$\epsilon_{c_n} = k_{c_n} (\lambda) \quad (23)$$

The constant factors, k_{a_n} and k_{c_n} , for the specific extinction coefficients have been determined from density³⁷ and infrared measurements.³⁹

Their values are:

$$k_{a_{1303}} = 26.47 \text{ cm.}^2/\text{g.}$$

$$k_{a_{1352}} = 40.29 \text{ cm.}^2/\text{g.}$$

$$k_{a_{1368}} = 59.67 \text{ cm.}^2/\text{g.}$$

$$k_{c_{1894}} = 6.10 \text{ cm.}^2/\text{g.}$$

The percent amorphous or crystalline material is then determined using equations (21) and (22) or (23).

$$1-\lambda = \frac{OD_n}{k_{a_n} \tau \rho} \quad (24)$$

$$\lambda = \frac{OD_n}{k_{c_n} \tau \rho} \quad (25)$$

APPENDIX III - INFRARED SPECTRA

Infrared spectra were determined on the initial four materials used in the study and on annealed (State III) Gulf 5555 1.5 mil film. The spectra were determined using a Perkin Elmer Model 21 Infrared Spectrophotometer. Model 21 is a double beam spectrophotometer with a sodium chloride prism capable of measuring absorption in the wavelength range of 2.5 to 15 μ . Checks for standardization were made with a 0.07 mm. polystyrene standard film (Figure 26). In all cases, films of 1.0-1.5 mil thickness were used with air as a reference.

The I-R spectra of the four base films are shown in Figures 27 and 28. The spectra determined at varying times as part of the crystallinity study are presented in chronological order in Figures 29-33.

Figure 26 INFRARED SPECTRA OF POLYSTYRENE STANDARD

105

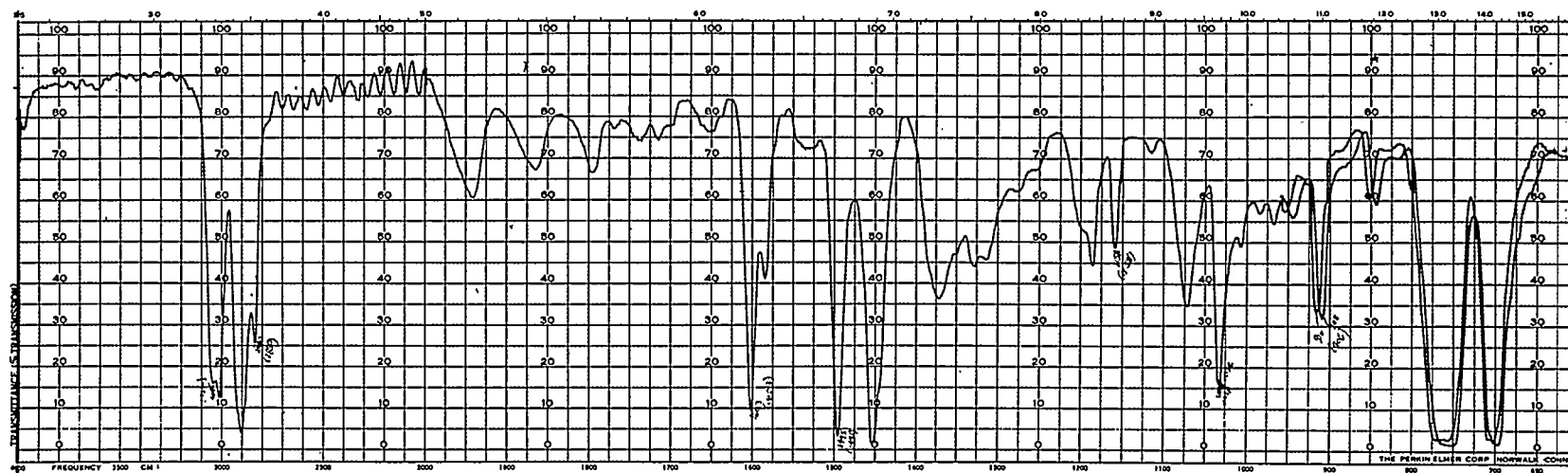
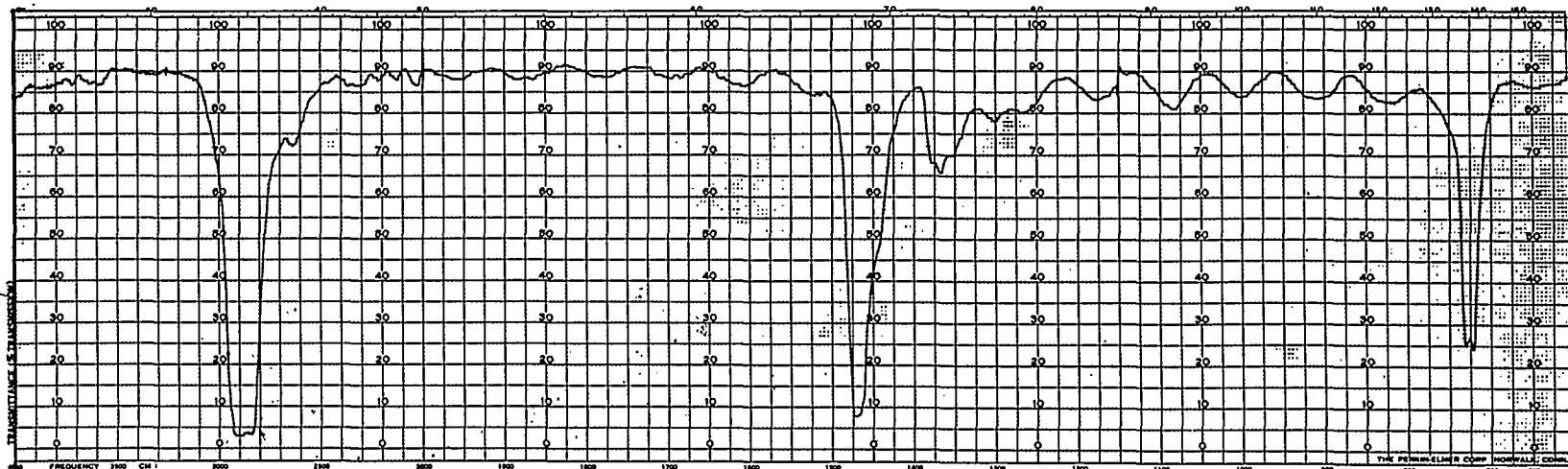
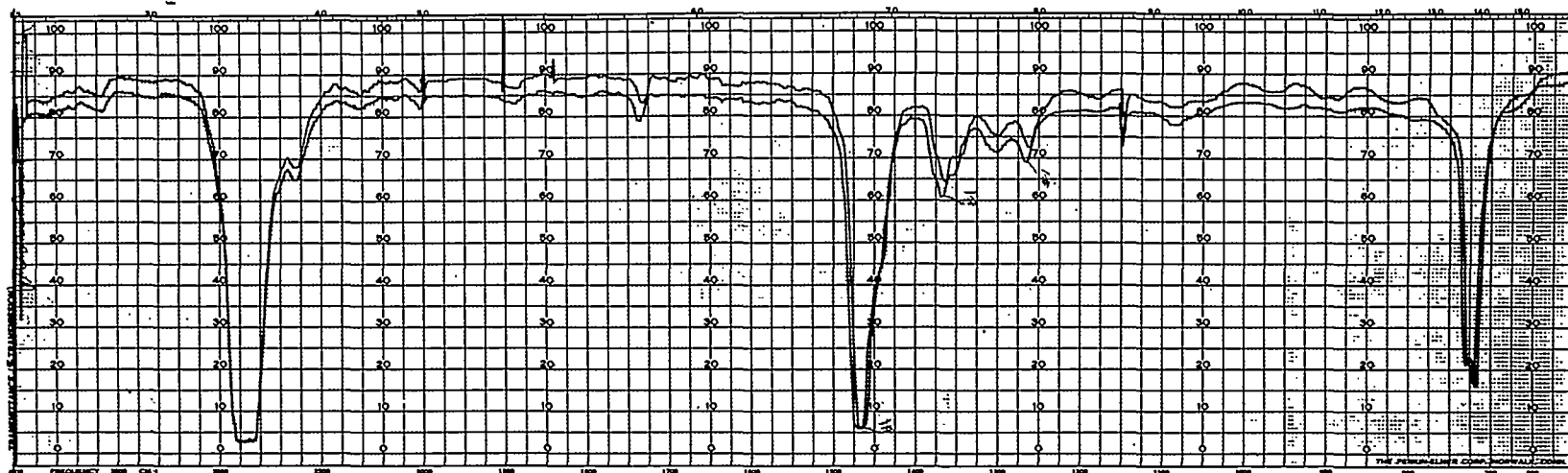

Figure 27 INFRARED SPECTRA OF POLYETHYLENES USED IN MAIN PART OF STUDY - GULF 5555 AND DUPONT SUPER C



GULF 5555



DUPONT SUPER C

Figure 28 INFRARED SPECTRA OF POLYETHYLENES USED IN MAIN PART OF STUDY - PHILLIPS 3328 AND PHILLIPS 6003



PHILLIPS 3328

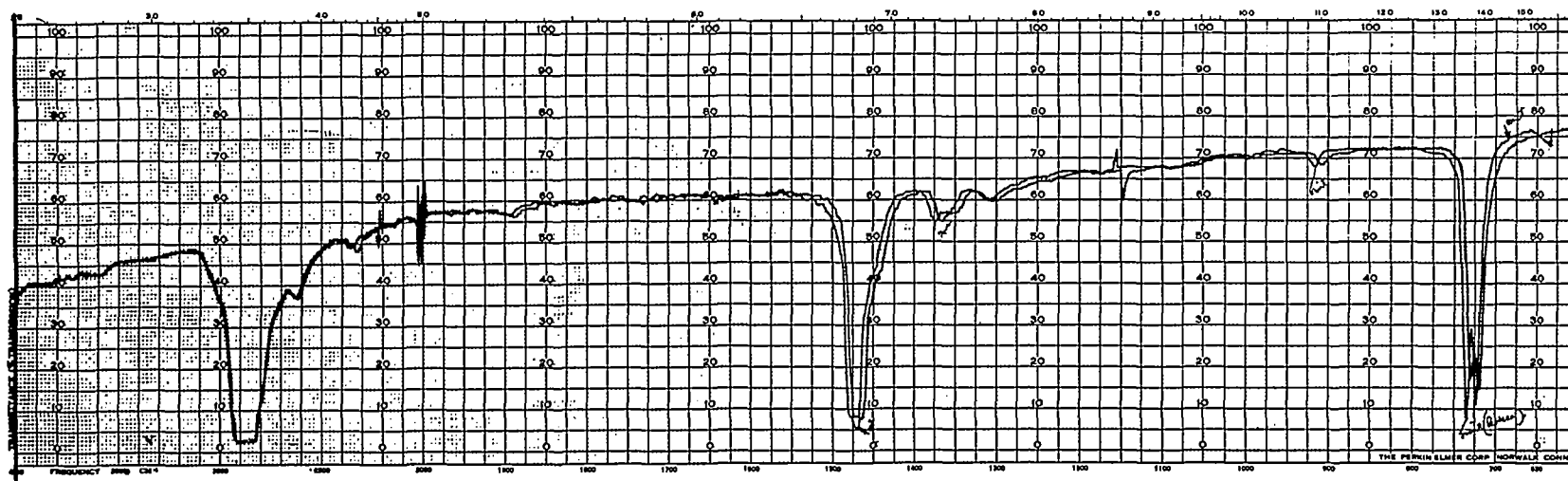

PHILLIPS 6003

Figure 29 INFRARED SPECTRA-TIME STUDY OF ANNEALED STATE III, CROSSLINKED,
GULF 5555 1.5 MIL POLYETHYLENE FILM - 0.14 HR. AND 0.31 HR.

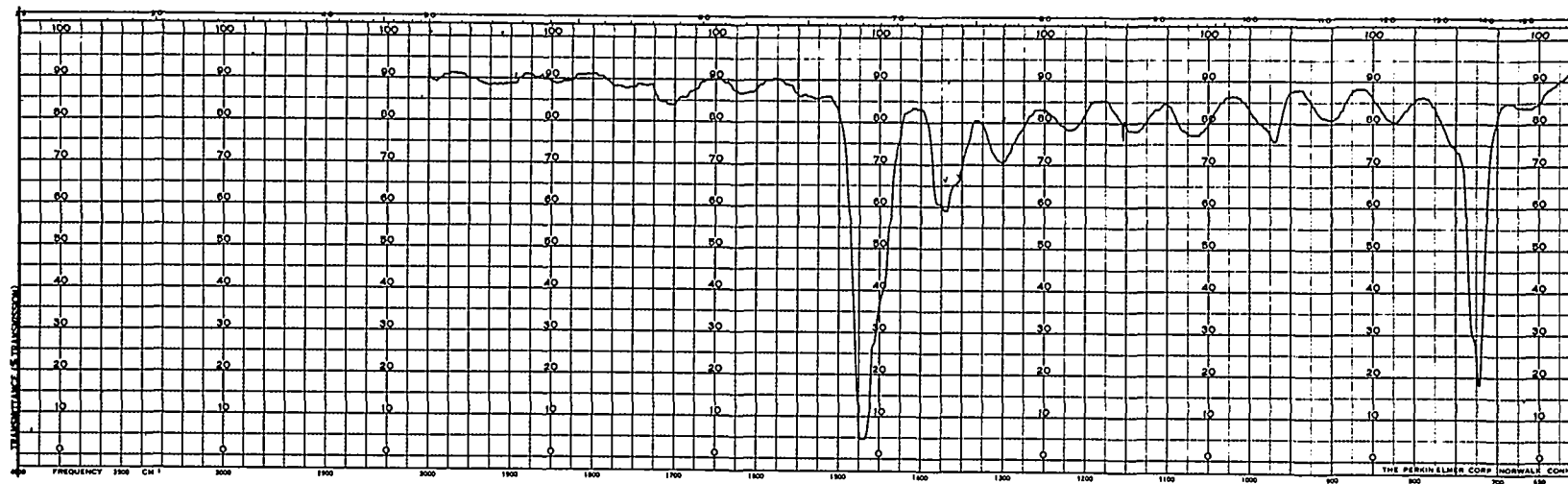

TIME = 0.14 HR.



TIME = 0.31 HR.

Figure 30 INFRARED SPECTRA-TIME STUDY OF ANNEALED STATE III, CROSSLINKED,
GULF 5555 1.5 MIL POLYETHYLENE FILM - 0.60 HR. AND 0.86 HR.

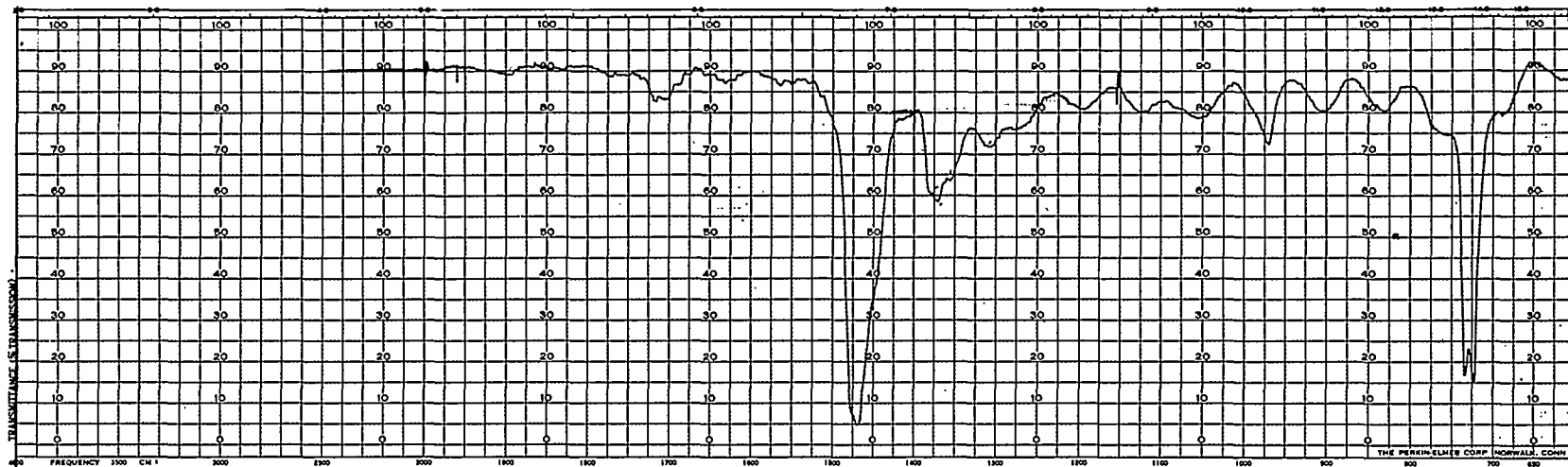

TIME = 0.60 HR.



TIME = 0.86 HR.

Figure 31 INFRARED SPECTRA-TIME STUDY OF ANNEALED STATE III, CROSSLINKED,
GULF 5555 1.5 MIL POLYETHYLENE FILM - 1.87 HR. AND 24.62 HR.

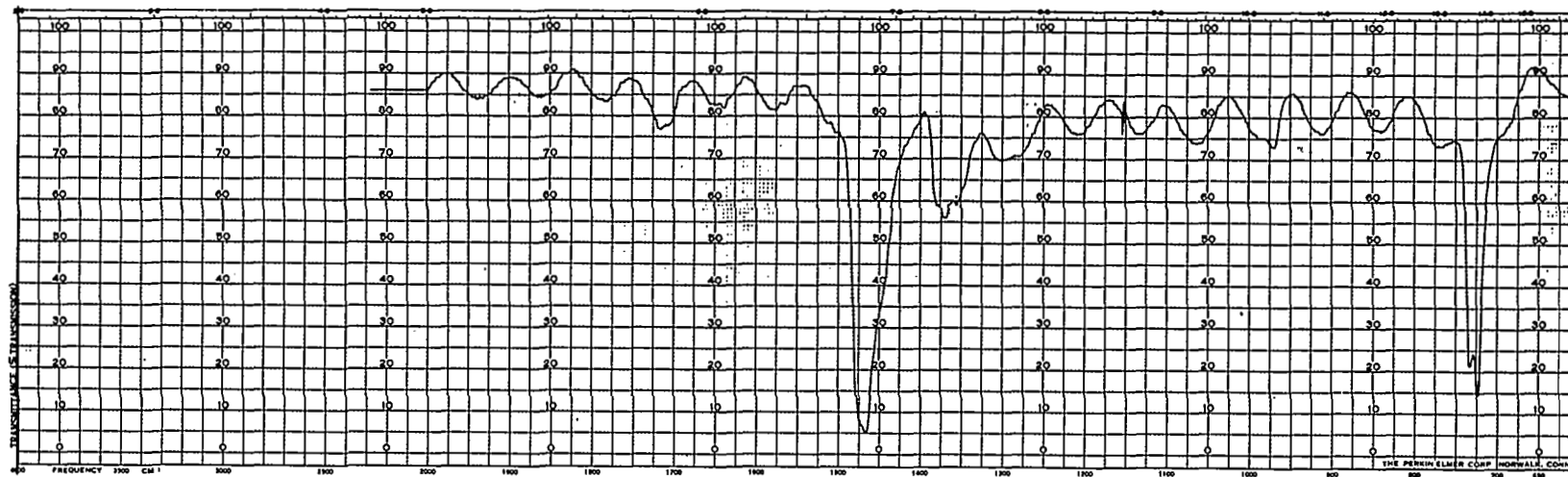

TIME = 1.87 HR.



TIME = 24.62 HR.

Figure 32 INFRARED SPECTRA-TIME STUDY OF ANNEALED STATE III, CROSSLINKED,
GULF 5555 1.5 MIL POLYETHYLENE FILM - 101 HR. AND 389 HR.

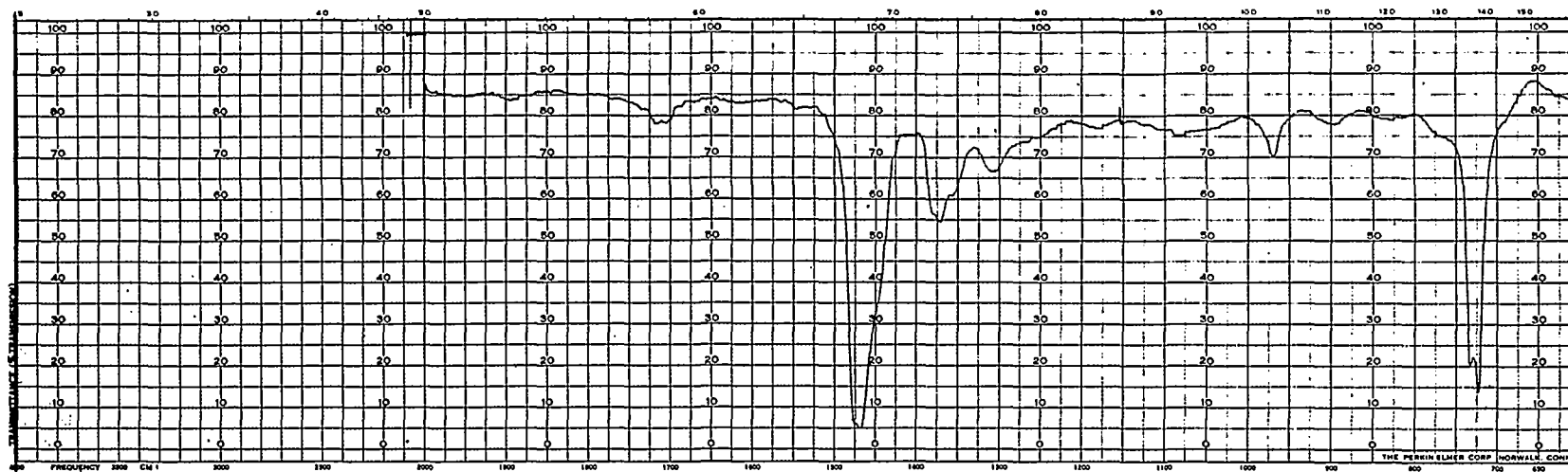

TIME = 101 HR.

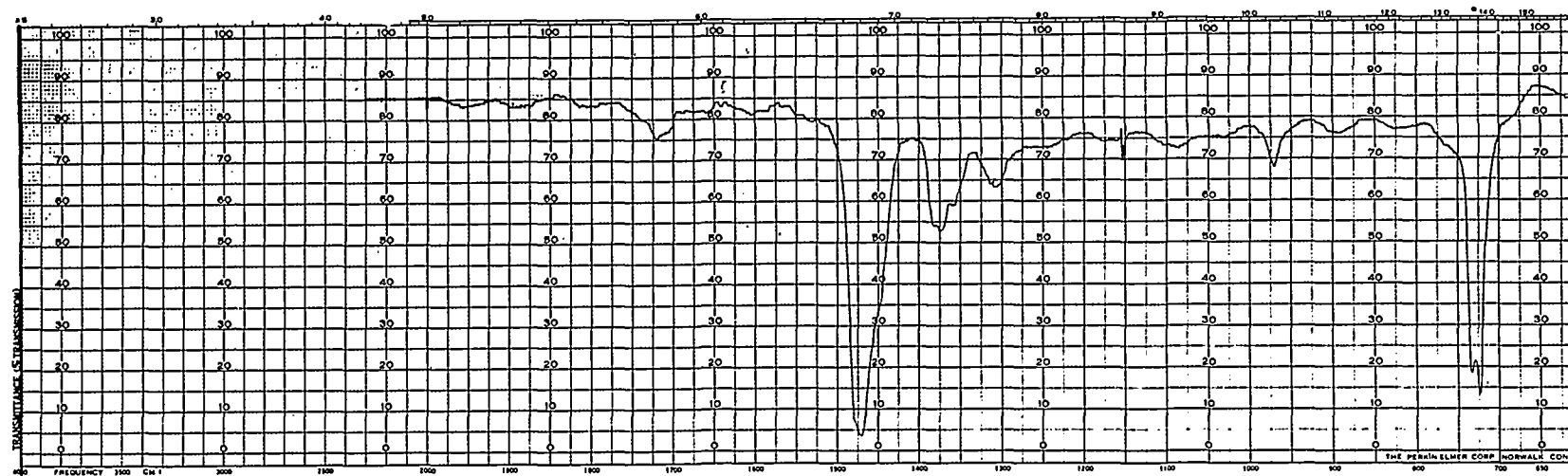

TIME = 389 HR.

Figure 33 INFRARED SPECTRA-TIME STUDY OF ANNEALED STATE III, CROSSLINKED,
GULF 5555 1.5 MIL POLYETHYLENE FILM - 700 HR.

