

## **General Disclaimer**

### **One or more of the Following Statements may affect this Document**

- This document has been reproduced from the best copy furnished by the organizational source. It is being released in the interest of making available as much information as possible.
- This document may contain data, which exceeds the sheet parameters. It was furnished in this condition by the organizational source and is the best copy available.
- This document may contain tone-on-tone or color graphs, charts and/or pictures, which have been reproduced in black and white.
- This document is paginated as submitted by the original source.
- Portions of this document are not fully legible due to the historical nature of some of the material. However, it is the best reproduction available from the original submission.

X-721-69-316

PREPRINT

NASA TM X-3

63688

# BAR GRAPH MONITOR

R. K. KOPSIDAS

R. J. STATTEL

P. L. HINDS

D. L. HARRIS

FACILITY FORM 602	<b>N69-38780</b>	
	(ACCESSION NUMBER)	(THRU)
	<u>13</u>	
	(PAGES)	(CODE)
	<u>Tmx-63688</u>	<u>01</u>
	(NASA CR OR TMX OR AD NUMBER)	(CATEGORY)

JULY 1969



**GODDARD SPACE FLIGHT CENTER**

**GREENBELT, MARYLAND**

X-721-69-316

BAR GRAPH MONITOR

R. K. Kopsidas  
R. J. Stattel  
P. L. Hinds  
D. L. Harris

Sounding Rocket Instrumentation Section

July 1969

GODDARD SPACE FLIGHT CENTER  
Greenbelt, Maryland

## ABSTRACT

The Bar Graph Monitor is a part of a pulse-position-modulation (PPM) telemetry system, used extensively for sounding rocket flights, and designed by the Sounding Rocket Instrumentation Section of Goddard Space Flight Center. This equipment provides a visual indication of all sixteen channels of a PPM ground station operating at frequencies of 5, 10, or 20 kilohertz. Indication is in the form of straight vertical bars displayed on a cathode ray tube.

PRECEDING PAGE BLANK NOT FILMED  
PRECEDING PAGE BLANK NOT FILMED

## CONTENTS

	<u>Page</u>
ABSTRACT . . . . .	iii
INTRODUCTION . . . . .	1
GENERAL INFORMATION . . . . .	3
FUNCTIONAL DESCRIPTION . . . . .	3
PHYSICAL DESCRIPTION . . . . .	3
CAPABILITIES AND LIMITATIONS . . . . .	3
THEORY OF OPERATION . . . . .	5
CARD 1 . . . . .	5
HORIZONTAL SWEEP . . . . .	5
VERTICAL SWEEP . . . . .	9
UNBLANKING PULSE . . . . .	9
CARD 2 . . . . .	10
OPERATION . . . . .	13
MAINTENANCE . . . . .	15
PREVENTIVE MAINTENANCE . . . . .	15
CORRECTIVE MAINTENANCE . . . . .	15
MODIFICATIONS TO OSCILLOSCOPE . . . . .	15

PRECEDING PAGE BLANK NOT FILMED.

## ILLUSTRATIONS

<u>Figure</u>		<u>Page</u>
	Frontispiece — Bar Graph Monitor . . . . .	viii
1	PPM Telemetry System, Block Diagram . . . . .	2
2	Bar Graph Monitor, Physical Details . . . . .	4
3	Bar Graph Monitor, Block Diagram . . . . .	6
4	Bar Graph Monitor, Timing Diagram . . . . .	7
5	Card 1, Schematic Diagram . . . . .	8
6	Card 2, Schematic Diagram . . . . .	11
7	Bar Graph Monitor, Waveshapes . . . . .	12
8	Oscilloscope, Wiring to Plug-In Unit Connectors . . . . .	17
9	Modifications to Oscilloscope . . . . .	18

## TABLE

<u>Table</u>		<u>Page</u>
I	BAR GRAPH MONITOR CONTROLS . . . . .	13

PRECEDING PAGE BLANK NOT FILMED.



BAR GRAPH  
MONITOR

Frontispiece — Bar Graph Monitor

# BAR GRAPH MONITOR

## INTRODUCTION

The Sounding Rocket Instrumentation Section of Goddard Space Flight Center has designed and implemented a pulse-position-modulation (PPM) telemetry system which is used extensively for sounding rocket flights. The system is used both for real-time missions in the field, and at the test or assembly station, where the experiments and rocket instrumentation are integrated and prepared for flight. Figure 1 shows a block diagram of the system.

The PPM telemetry system consists of two major systems: the airborne PPM system aboard the sounding rocket, and a PPM ground station system that receives and records the data transmitted by the airborne system. This report deals exclusively with the bar graph monitor of the PPM ground station, and provides general functional and physical information, theory of operation, operating instructions, and maintenance procedures.



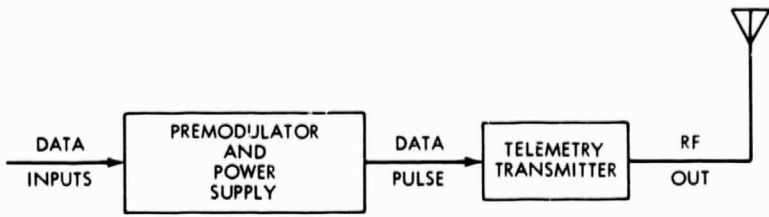

SST-3 TELEMETER

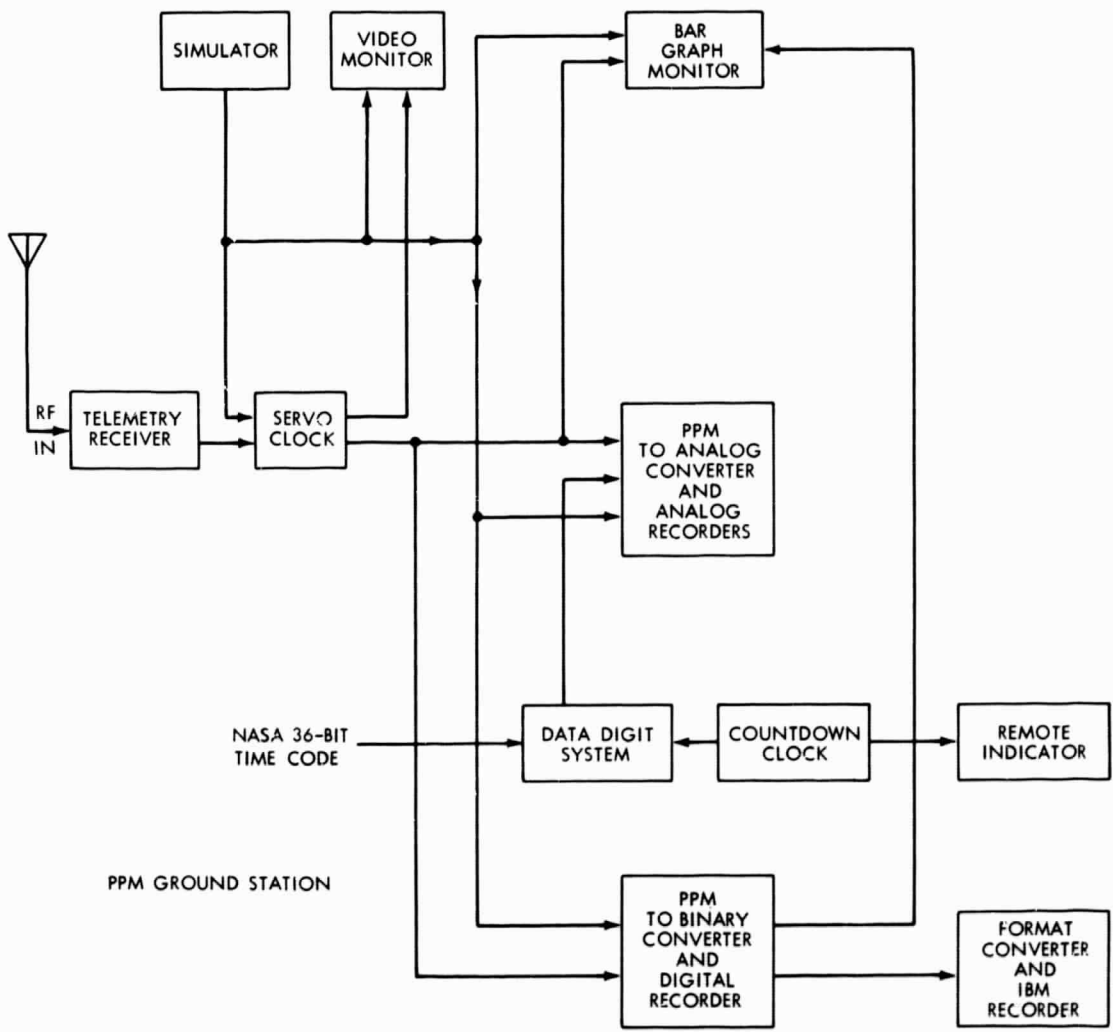

Figure 1. PPM Telemetry System, Block Diagram

## GENERAL INFORMATION

### FUNCTIONAL DESCRIPTION

The bar graph monitor provides a visual indication of all sixteen channels of a PPM telemetry ground station for 5, 10, and 20-kilohertz operation. As the name implies, this indication is in the form of straight vertical bars presented on a Tektronix Model RM-561A Oscilloscope, modified to display this format.

### PHYSICAL DESCRIPTION

The bar graph monitor is contained on one plug-in unit that fits into a stock Tektronix RM-561A Oscilloscope. See Figure 2. The overall dimensions of the bar graph monitor are 4 inches wide by 6 inches high by 12-1/2 inches deep. The weight is approximately 8 pounds and the volume is approximately 300 cubic inches. Card 1, in the plug-in unit, contains the solid-state electronic circuitry that generates the horizontal and vertical sweeps, and the unblanking pulse. Card 2, in the plug-in unit, contains the horizontal and vertical sweep amplifiers.

### CAPABILITIES AND LIMITATIONS

Power Requirement:	Less than 15 watts from a +10, -10, +3, -3 volt dc power supply
Operating Temperature Range:	+15 degrees C to +55 degrees C (+59 degrees F to +131 degrees F)
Inputs:	Accepts pulses of -10 to zero or zero to +10 volts peak, at a reference and data rate of 5, 10, and 20 kilohertz, and a frame rate of 312, 624, and 1248 hertz.

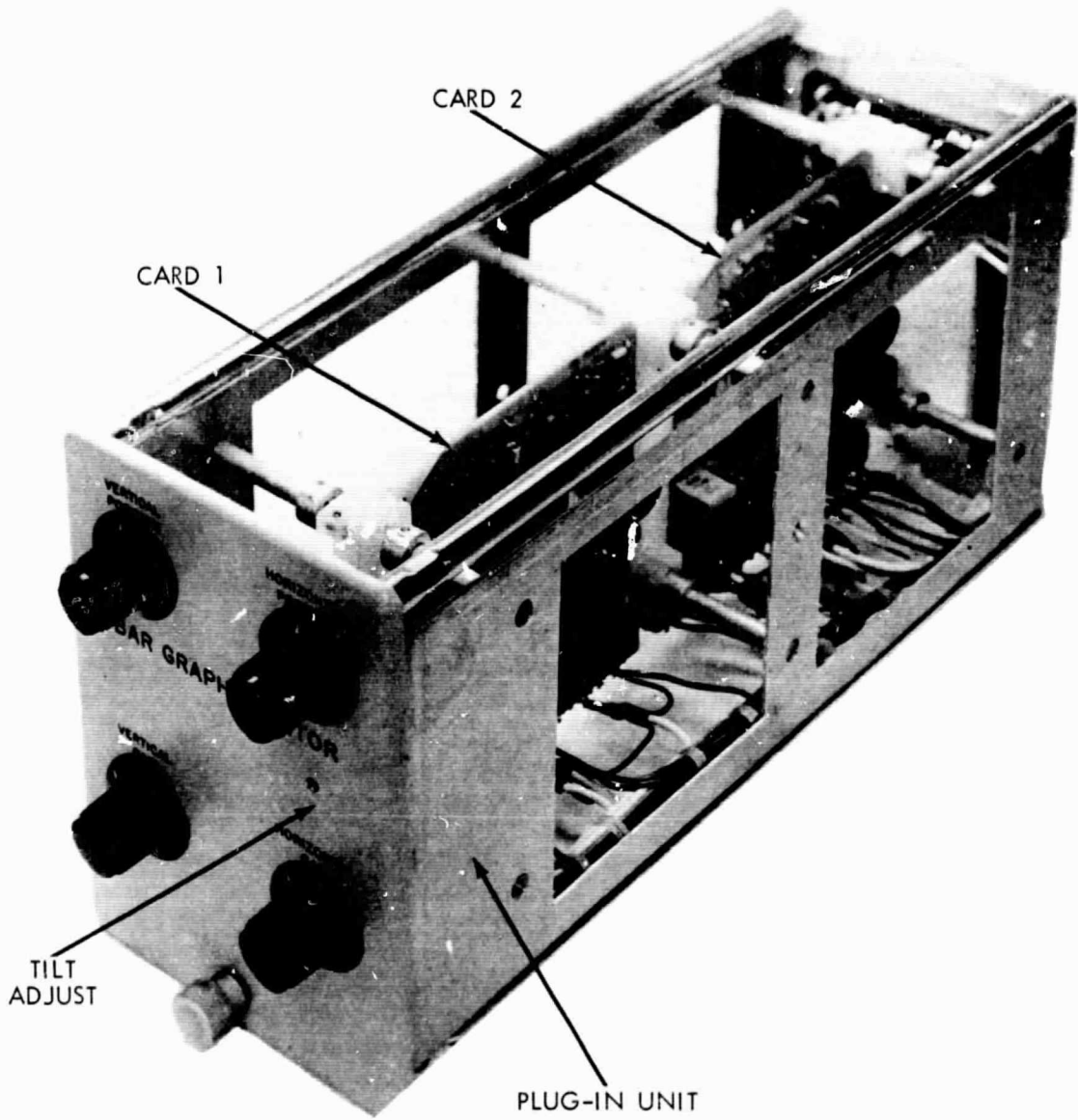

Figure 2. Bar Graph Monitor, Physical Details

## THEORY OF OPERATION

Most of the signal processing is accomplished with micrologic units, driven by a small voltage regulator. Timing and amplitudes are somewhat independent of voltage supply, and time constants have been carefully selected to eliminate the need for adjustments.

The horizontal sweep is generated by the frame of the ground station, and the vertical sweep is generated by the reference of the station. See Block Diagram, Figure 3. The data pulse, together with the reference pulse, are used to generate the unblanking pulse.

### CARD 1

**HORIZONTAL SWEEP.** The electronic circuitry for the above functions is contained on Card 1. Assume that the station is operating at a 5-kilohertz rate. The horizontal sweep is generated as follows: the incoming frame is a negative pulse of approximately 4-microseconds duration, with a zero to -10 volt peak amplitude, and it has a period of 3.2 milliseconds (see Figure 4, waveshape A). These frame pulses are inverted and clamped so that their level is from zero to +3 volts peak (Figure 4, waveshape B). The frame pulses are used to generate a linear sweep of approximately 8 volts peak amplitude. The sweep is amplified, and drives the electron beam horizontally across the face of the cathode ray tube (CRT).

Positive pulses, on the base of transistor Q2 (Figure 5), short the collector to ground for the duration of the pulse, which is approximately 4 microseconds. After the pulse, transistor Q2 stops conducting, and series-capacitors C4 and C5 begin charging linearly, from zero volts to the supply voltage, at a rate that is a function of the resistive-capacitive (RC) time constant. The RC time constant is selected so that the amplitude of the ramp function reaches 8 volts just before the next frame pulse shorts it to ground again. This linear ramp-function circuit is followed by a super-alpha-emitter-follower, consisting of transistors Q3 and Q4. Part of the output voltage is fed back to the common point of capacitors C4 and C5, through resistor R16, to improve linearity.

The +10-volt dc power supply is regulated, and stepped-down to 9.1 volts, so that the amplitude of the ramp function is independent of power supply variations. Relays K1 and K2, with double sets of contacts, select the RC time constant for the particular frequency of operation desired.

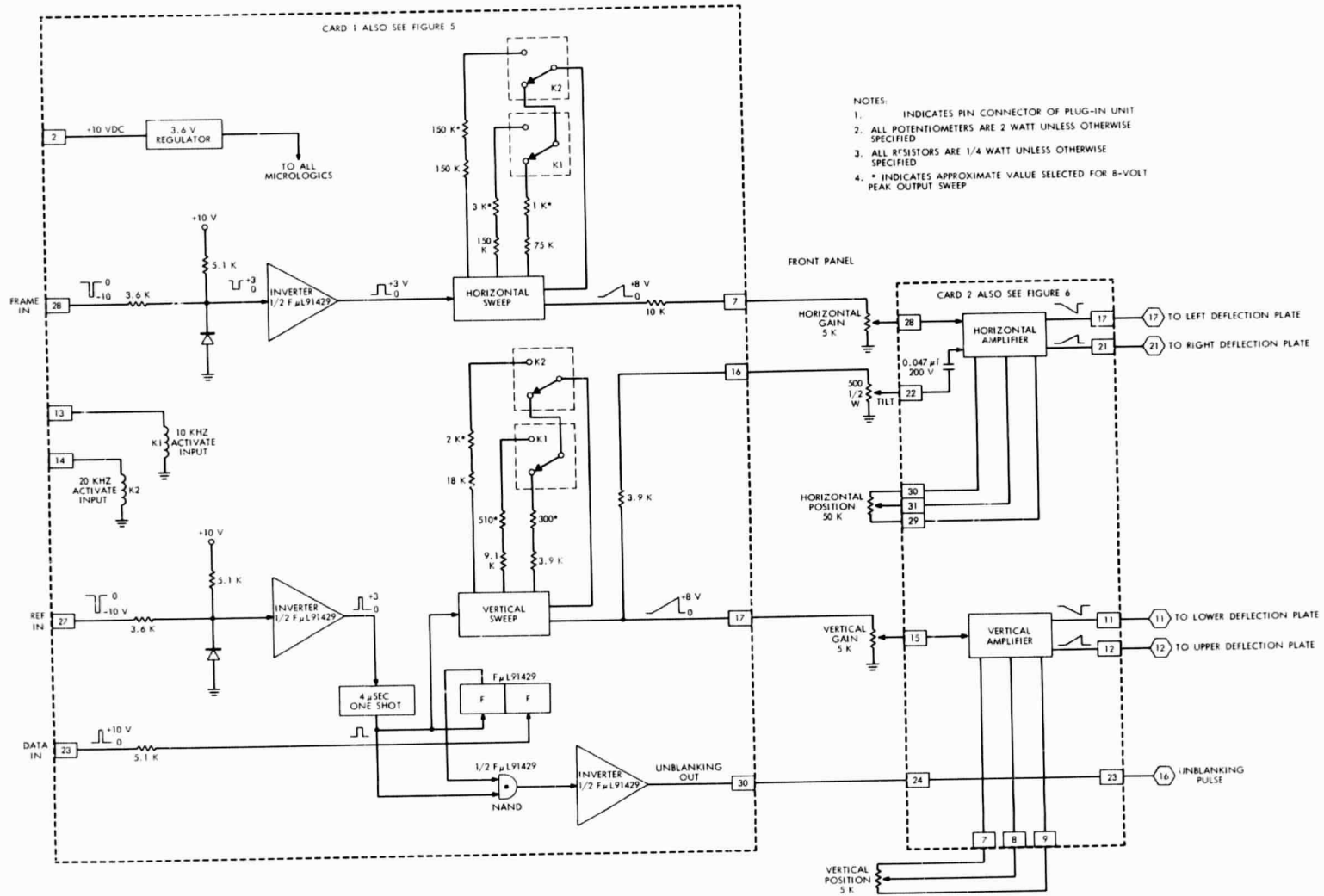
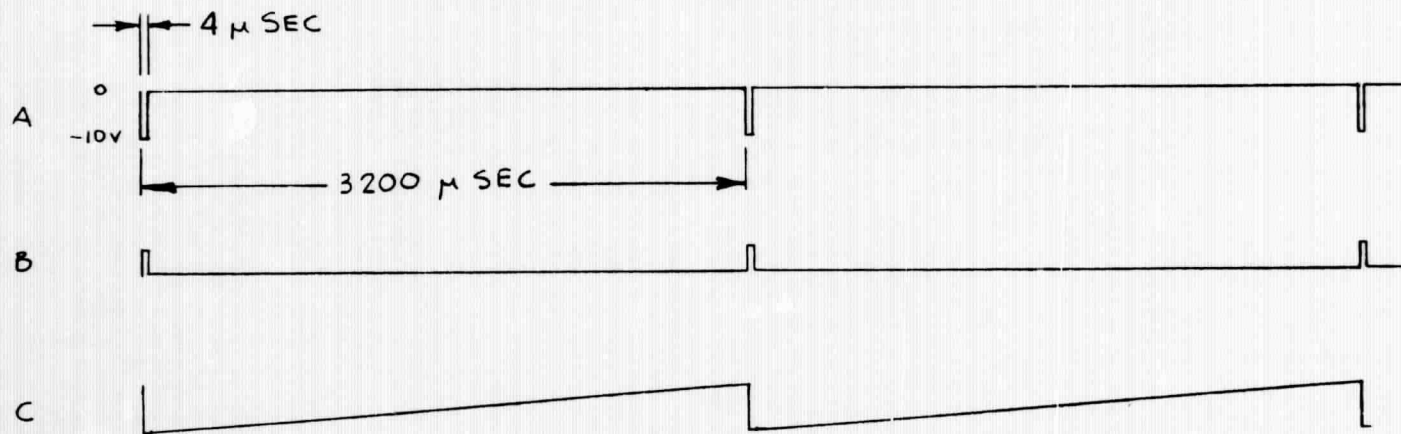

Figure 3. Bar Graph Monitor, Block Diagram



- A - FRAME FOR 5kHz OPERATION
- B - FRAME INVERTED
- C - HORIZONTAL SWEEP

Figure 4. Bar Graph Monitor, Timing Diagram

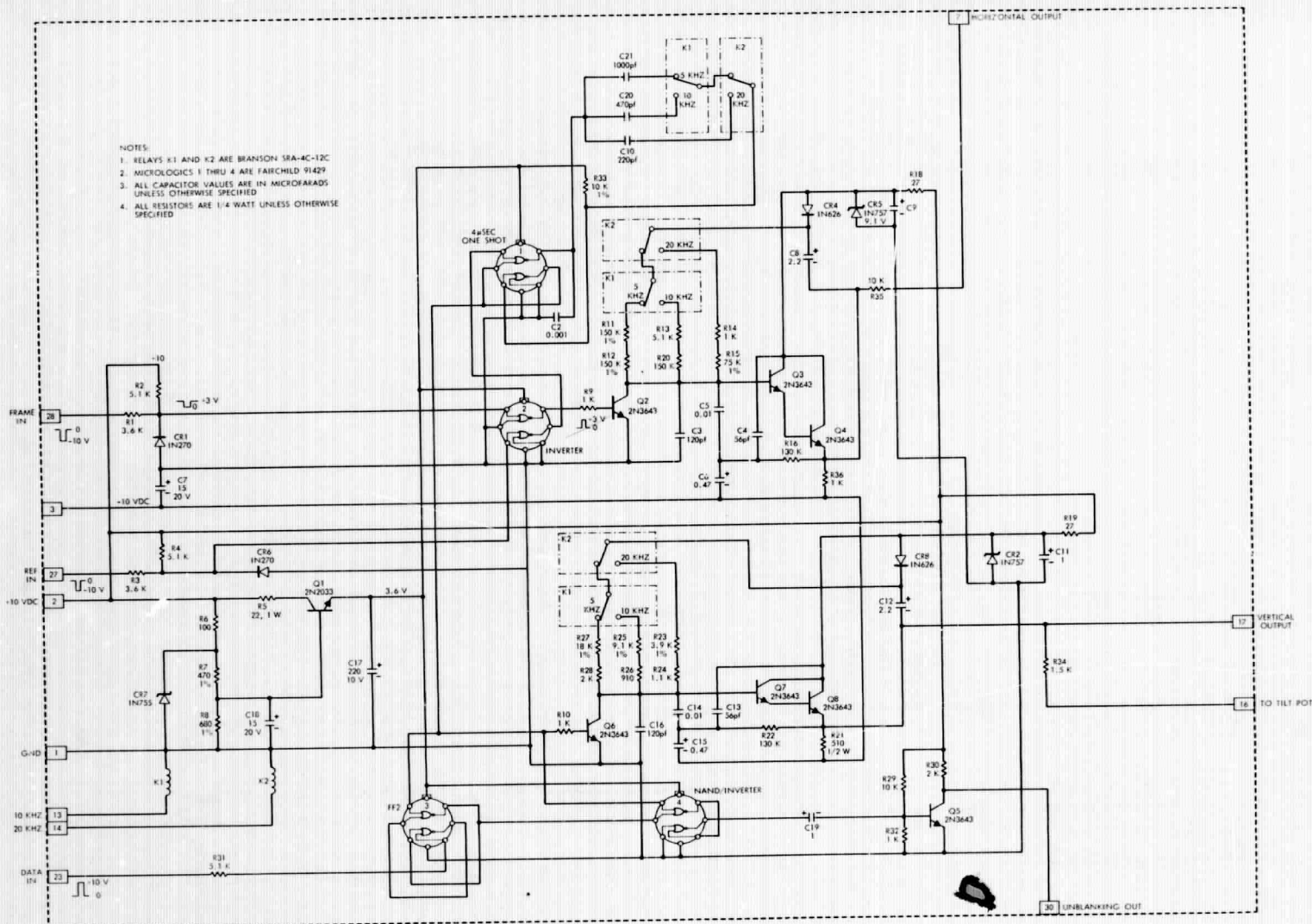

Figure 5. Card 1, Schematic Diagram

**VERTICAL SWEEP.** The vertical sweep is generated by the ground station reference pulse. The vertical sweep circuit is identical with the horizontal sweep circuit, except for a different time constant, which is caused by the higher repetition rate of the reference pulses. The amplitude of the vertical sweep is approximately 8 volts, and, because of the selection of the time constant, is the same for 5, 10, and 20 kilohertz operation. The amplified vertical sweep drives the CRT electron beam vertically.

**UNBLANKING PULSE.** The function of the unblanking pulse is to unblank the electron beam of the CRT, for time periods that start at the beginning of every channel, and end when the data pulse appears. To achieve this, a negative pulse, which starts at the beginning of the channel and ends when the data pulse appears, is generated. The unblanking pulse is generated only when both reference and data pulses are present. The inverted and squared reference pulse sets a multivibrator in one state, thus starting the unblanking pulse. The data pulse resets the multivibrator to the original state, thus terminating the generated pulse. (See Waveshape C, Figure 4). The resultant negative pulse is used as an unblanking pulse; that is, whatever part of the vertical sweep is coincident with the unblanking pulse will be displayed on the CRT.

At the beginning of every channel, the vertical sweep shorts to zero potential, and the CRT electron beam returns from the upper side of the CRT to the bottom side, prior to starting a new vertical sweep. The time that the beam requires to return from the top of the CRT to the bottom is called retrace time, and is blanked as follows: reference pulses trigger a one-shot multivibrator that generates 20, 7.5, and 1.75 microsecond pulses for 5, 10 and 20 kilohertz operation, respectively. The width of these pulses is so selected that the difference of the guard-band and the pulse width will be generally fixed at 5 microseconds, that is:

Guard-Band (in microseconds)	minus	Pulse Width (in microseconds)
25.00		20.00
12.50		7.50
6.25		1.75

These pulses are combined with the pulses of waveform C, Figure 4, so that the CRT is blanked for the first part of the channel. The pulses are then ac-coupled to an inverter, and are used as unblanking pulses. The final output of the unblanking pulse is normally zero with no input pulse, because transistor Q5,



Figure 5, is normally on. This ensures that the CRT will always be blanked when reference pulses or data pulses, or both, are absent. That is, when one of the plug-in units, such as the simulator or servo clock, has been removed.

## CARD 2

Card 2 consists of the horizontal and vertical amplifiers, Figure 6. The high-voltage-amplifier card receives the low amplitude horizontal and vertical sweeps, and amplifies them to 70-100 volts peak. The same card, without modifications, is used for both the bar graph monitor and the video monitor. Horizontal sweep enters the card at pin 28, and is fed directly to the base of transistor Q7. As the sweep voltage increases in amplitude, transistor Q7 conducts and the potential of its collector decreases, thus amplifying and inverting the input horizontal sweep. Since the emitter is of the same polarity as the base, transistor Q9 tends to shut-off, making the collector waveshape of transistor Q9 follow the input horizontal sweep. Both transistors Q7 and Q9 are followed by an emitter-follower which drives the two horizontal deflection plates. The horizontal position potentiometer is used to bias transistor Q7 so that its collector voltage moves up and down, pulling the beam of the CRT horizontally from one side to the other.

The vertical amplifier circuit operation is identical to the horizontal amplifier circuit operation. The vertical sweep is fed through the gain potentiometer, and comes out as both negative and positive sweep, on pins 11 and 12. Part of the vertical sweep is fed into the horizontal amplifier through the tilt potentiometer and capacitor C4, to modulate the horizontal sweep so that the slope of the bar-graph lines on the CRT can be adjusted vertically. During the channel period, Figure 7, waveshapes D and E, the positive and negative horizontal sweep remains constant, because of the amount of vertical sweep modulating the high voltage horizontal amplifier. Since the horizontal sweep is maintained constant during the channel period, the CRT electron beam will not move horizontally, but will move vertically. The resultant vertical line on the CRT has an amplitude proportional to the unblanking pulse.

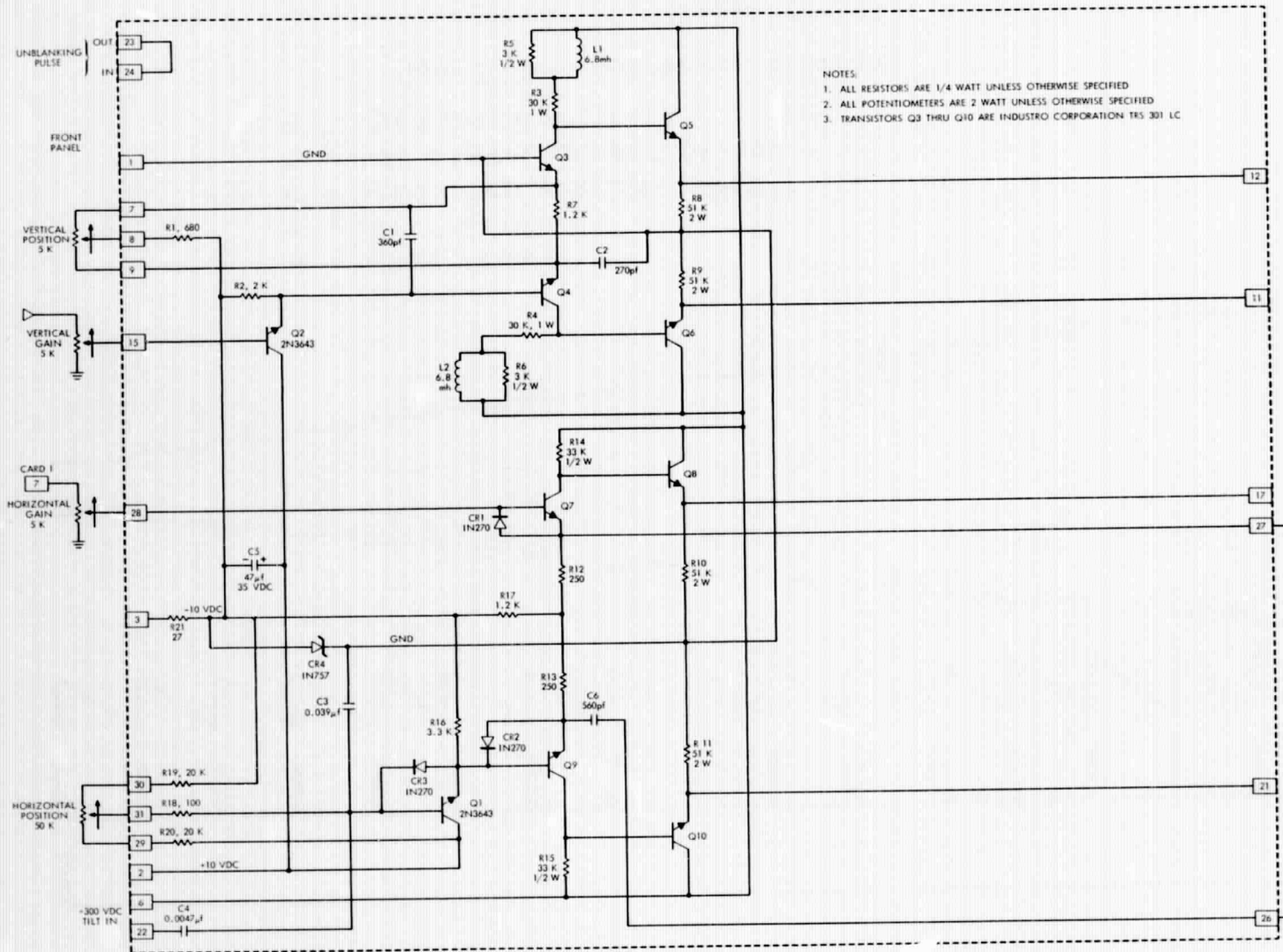
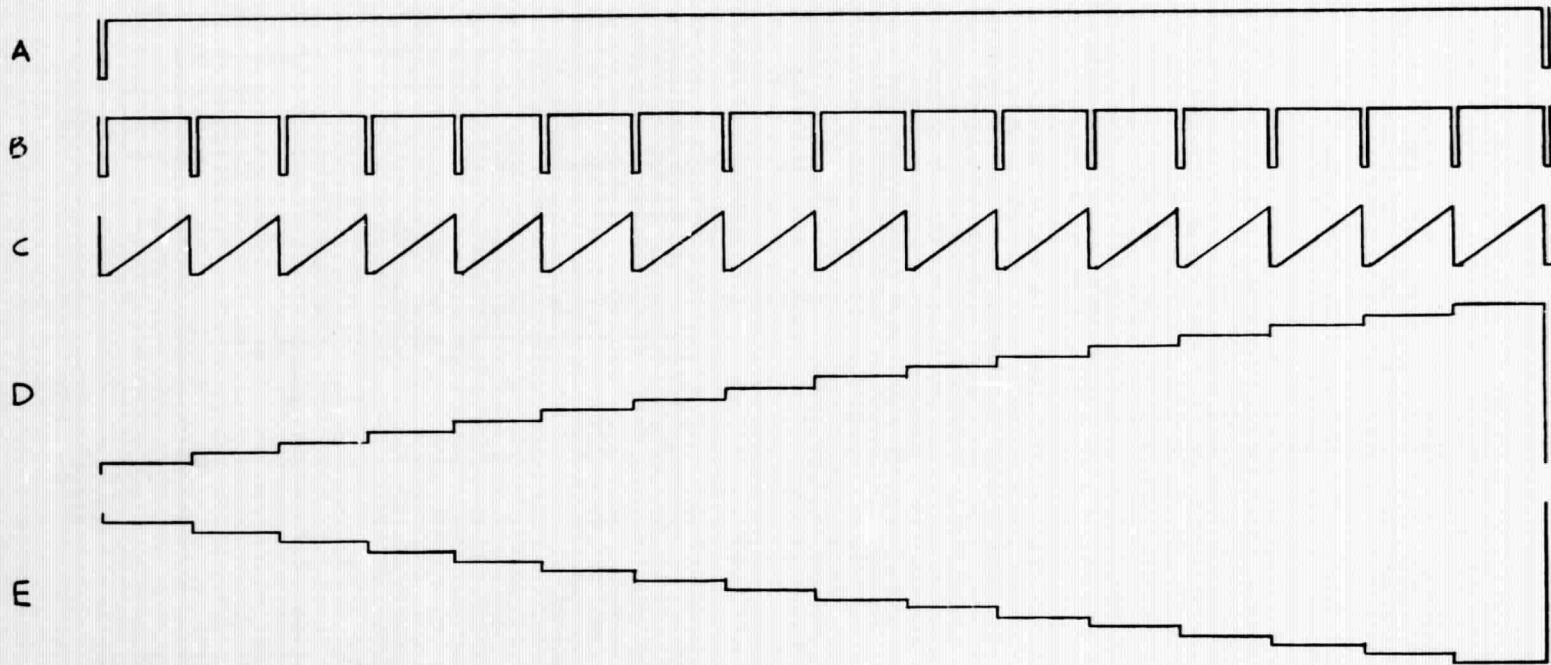

Figure 6. Card 2, Schematic Diagram



A - INPUT FRAME  
 B - INPUT REF  
 C - GENERATED VERTICAL SWEEP  
 D } HORIZONTAL OUTPUT OF HIGH  
 E } VOLTAGE AMPLIFIER

Figure 7. Bar Graph Monitor, Waveshapes

## OPERATION

Table I lists the controls, and the adjustment used by the operator, to adjust the display.

Table I  
BAR GRAPH MONITOR CONTROLS

Control	Function
VERTICAL POSITION	Controls the vertical positioning of the CRT display
HORIZONTAL POSITION	Controls the horizontal positioning of the CRT display
VERTICAL GAIN	Controls the vertical size of the CRT display
HORIZONTAL GAIN	Controls the horizontal size of the CRT display
TILT (Screwdriver Adjustment)	Controls the slope of the CRT display

## MAINTENANCE

This system has been designed with no internal adjustments. The time constants of the sweeps are carefully selected so that all sweeps, at all frequencies, have the same amplitude.

The lone adjustment is the tilt potentiometer, located on the front of the plug-in unit (unmarked screwdriver adjustment). This control is used to adjust the slope of the vertical bars.

### PREVENTIVE MAINTENANCE

Preventive maintenance consists of general cleaning and periodic visual inspection. Accumulations of dust, dirt, grit and/or grease on circuit boards is harmful, and should be guarded against by periodic inspection and cleaning. Every three to six months, visually inspect the equipment for signs of deterioration, loose connections, security of mounting, and foreign matter. The periods between cleanings depends on the particular operating environment, and should be determined by visual inspection. As necessary, clean with a soft brush or low air pressure, being careful not to damage printed circuitry.

### CORRECTIVE MAINTENANCE

Before attempting the repair of circuit boards suspected of malfunction, verify that the symptom is not caused by malfunction of associated equipment such as the mounting case or inter-cabling. Once the existence of a defective plug-in module or circuit board has been established, visually inspect it for obviously damaged components such as burned resistors. Next ensure that the correct operating power is applied to the case and that the power supply potentials are correct. Make corrections as indicated.

### MODIFICATIONS TO OSCILLOSCOPE

The bar graph monitor is housed in a modified Tektronix RM-561A Oscilloscope. The standard oscilloscope horizontal and vertical plug-in units have been replaced with special plug-in units, the simulator or servo clock in the left side and the bar-graph monitor or video monitor in the right side of the oscilloscope housing.

PRECEDING PAGE BLANK NOT FILMED.

Wiring for the back connectors to the plug-in units is shown on Figure 8. The intensified circuit (or unblanking), which is located on the bottom of the oscilloscope, inside the high voltage plate, is modified as shown on Figure 9. The 2N1156 is a high-voltage transistor that generates a 44-volt positive unblanking pulse, which is ac-coupled to the grid of the CRT (pin 3). The amplitude of this pulse is clamped to 44 volts by two 1N722 zener diodes. This intensifying pulse has a fixed amplitude so that the CRT display has fixed brightness.

For additional information on the Tektronix RM-561A Oscilloscope, refer to the manufacturer's instruction manual.

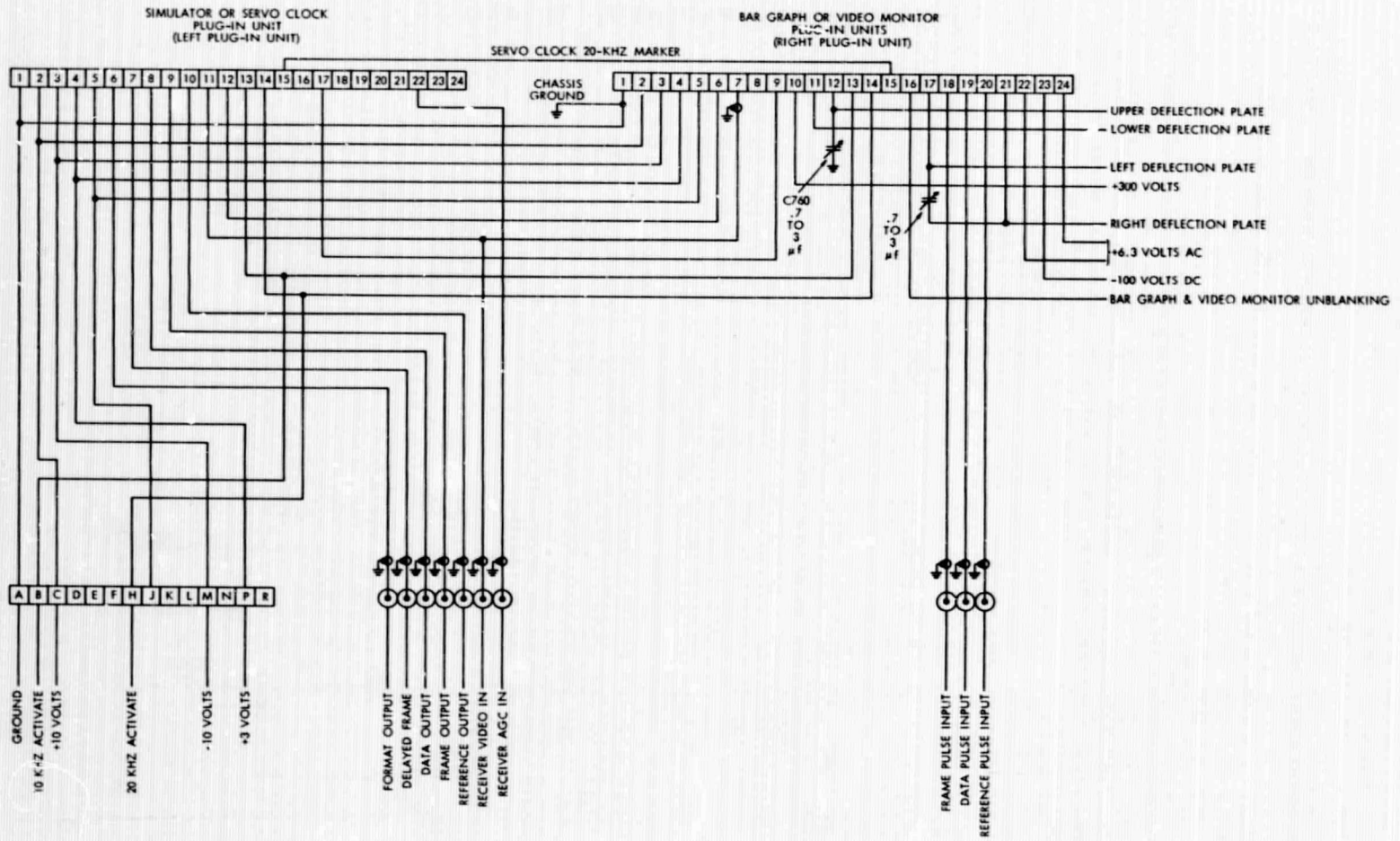

Figure 8. Oscilloscope, Wiring to Plug-In Unit Connectors

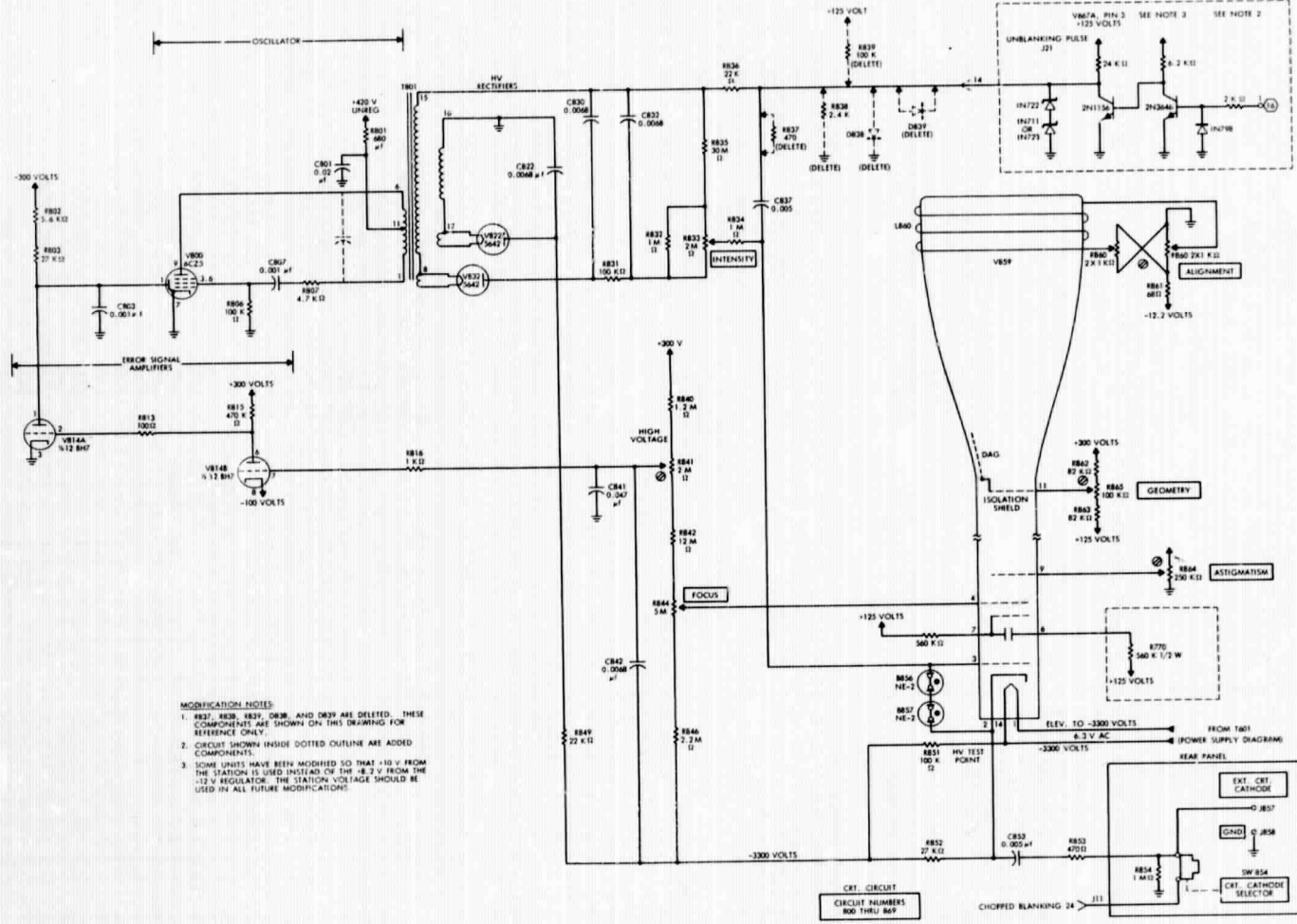

Figure 9. Modifications to Oscilloscope