

N 70 28 64 0

**NASA TECHNICAL  
MEMORANDUM**

NASA TM X-52772

NASA TM X-52772

**CASE FILE  
COPY**

**IRRADIATION EFFECT AT CRYOGENIC TEMPERATURE ON TENSILE  
PROPERTIES OF TITANIUM AND TITANIUM-BASE ALLOYS**

by Charles L. Younger and Fred A. Haley  
Lewis Research Center  
Cleveland, Ohio

**TECHNICAL PAPER** proposed for presentation at  
Symposium on the Effects of Radiation on Structural Materials  
sponsored by the American Society for Testing and Materials  
Niagara Falls, Ontario, Canada, June 29-July 1, 1970

**IRRADIATION EFFECT AT CRYOGENIC TEMPERATURE ON TENSILE  
PROPERTIES OF TITANIUM AND TITANIUM-BASE ALLOYS**

by Charles L. Younger and Fred A. Haley

Lewis Research Center  
Cleveland, Ohio

**TECHNICAL PAPER** proposed for presentation at  
Symposium on the Effects of Radiation on Structural Materials  
sponsored by the American Society for Testing and Materials  
Niagara Falls, Ontario, Canada, June 29-July 1, 1970

**NATIONAL AERONAUTICS AND SPACE ADMINISTRATION**

IRRADIATION EFFECT AT CRYOGENIC TEMPERATURE ON  
TENSILE PROPERTIES OF TITANIUM AND  
TITANIUM-BASE ALLOYS

by Charles L. Younger and Fred A. Haley

Lewis Research Center  
National Aeronautics and Space Administration  
Cleveland, Ohio

ABSTRACT

Significant increases in tensile strength and slight decreases in ductility occur when titanium and titanium-base alloys are irradiated at 17 K to 1 to  $10 \times 10^{17}$  fast neutrons per square centimeter. The magnitude of the irradiation effect appears to depend on total alloy content, and, over the fluence range investigated, does not reveal a significant dependence on impurity content or initial heat treated condition. These results were obtained using commercially pure titanium, Ti-5Al-2.5Sn (normal impurity and extra-low impurity contents), Ti-6Al-4V (annealed and age-hardened conditions), and Ti-8Al-1Mo-1V alloys. Test specimens were exposed to irradiations at 17 K and then tensile tested at 17 K without intervening warmup using test loops specially designed and fabricated for cryogenic-irradiation testing. Additional results, using commercially pure titanium, show recovery of about 50 percent of the irradiation-induced increase in yield

E-4975

strength following heat-treatment at 178 K. For the ultimate strength, 50 percent recovery occurred following heat-treatment at 78 K.

KEY WORDS: irradiation, radiation effects, cryogenic temperature, titanium, titanium alloys, tensile properties, heat treatment

### INTRODUCTION

The titanium-base alloys are finding wide acceptance for use at liquid hydrogen temperature (20 K). These alloys are also candidate materials for nuclear rocket applications where the nuclear environment is imposed on a structural material which is at the cryogenic temperature.

The tensile behavior of the various titanium-base alloys as a function of cryogenic temperature is now fairly well established (e. g., Ref. 1). In general, most titanium-base alloys experience a marked decrease in elongation and reduction of area as the temperature is reduced to 20 K. At temperatures below about 78 K, only a few alloys experience plastic deformation prior to failure. The tensile behavior of titanium alloys as a function of irradiation (Refs. 2-12), however, has received only minor attention. There is some evidence (Refs. 2, 8-11) that cryogenic temperatures accelerate the onset of brittle behavior for irradiated commercially pure titanium and the Ti-5Al-2.5Sn alloy.

To further investigate the effect of nuclear irradiation on embrittlement of titanium and titanium alloys at cryogenic temperature, an experimental program was undertaken at NASA's Plum Brook Reactor Facility. Test materials included in the program were selected to be representative of the various titanium-base alloys suitable for use at cryogenic temperatures. Tests were conducted using specially designed test equipment capable of maintaining the test specimen at 17 K throughout irradiation exposure and post-irradiation tensile testing. The objectives of this test program were to determine the radiation damage threshold - that is, the fluence at which changes in tensile properties became significant for each alloy - and to investigate the effects of impurities and heat treatment on this threshold.

#### EXPERIMENTAL PROCEDURES

Tensile test data for various titanium alloys were obtained using miniature round tension test specimens and specially designed test equipment installed at the Plum Brook Reactor Facility. The program was conducted, as nearly as feasible, in accordance with the provisions of ASTM Standards E199 (Ref. 13), E8 (Ref. 14), and E184 (Ref. 15). Unirradiated control tests were conducted in a test loop under the same test conditions as their irradiated counterparts. For each of the test materials in the program, at least three specimens were tested for each exposure condition.

### Test Materials

Test materials were commercially pure titanium (CP Ti); Ti-5Al-2.5Sn, NI (normal impurity content); Ti-5Al-2.5Sn, ELI (extra-low impurity content); Ti-6Al-4V, annealed; Ti-6Al-4V, aged; and Ti-8Al-1Mo-1V. All test materials were obtained as 0.5-inch (1.27-cm) diameter round bar stock. Stock materials were prepared by consumable electrode vacuum arc melting, forging to 1.5-inch (3.81-cm) square bar at 1200 to 1422 K, rolling to 0.5-inch (1.27-cm) diameter round bar at 978 to 1256 K, and then heat treating. Material compositions and heat treated conditions are given in table I.

### Test Specimens

The tensile test specimen (Fig. 1) was a geometrically similar miniaturization of the standard 0.5-inch (1.27-cm) round tension specimen of ASTM E8 (Ref. 14). This specimen had a gage uniform section of 0.125-inch (0.3175-cm) diameter by 0.875-inch (2.225-cm) length. Gage marks were inscribed by light sandblasting to delineate a 0.5-inch (1.27-cm) gage length. Ratios of significant dimensions were the same as for the standard ASTM specimen.

### Test Equipment

The major components of the test equipment are shown in Figure 2, and include a helium refrigeration system, test loops, and transfer tables. The test loop body (Fig. 3) contained a horizontally placed 5000-pound (22,241-N) capacity test machine

together with the necessary load actuation components, stress-strain monitoring instrumentation, and vacuum insulated refrigerant transfer lines. The forward section, or head assembly, served both as a fixed crosshead of the test machine and a cryostat for temperature control. The head assembly was removable by remote handling methods to allow specimen change. Detailed discussions of the test equipment and its operation are given elsewhere (Refs. 16-19).

#### Test Procedure

The typical testing sequence can readily be followed by reference to Figure 2. A test loop was inserted into the hot cave for specimen installation. After specimen installation, the loop was withdrawn from the hot cave to the north table in Quadrant D. Refrigerant flow was started and the table holding the loop was rotated  $180^{\circ}$ . The loop was then transferred to the south table and positioned in-line with HB-2 and, after stabilization of specimen temperature at 17 K, inserted into HB-2. The loop was held in this position with the specimen maintained at 17 K until the required fast neutron fluence was attained. The test loop was then retracted approximately 4 feet (1.2-m) and an axial tensile load was applied to the specimen. After specimen failure, the loop was returned to the hot cave for specimen replacement.

Specimen temperature control. - Direct measurement of the specimen temperature was not feasible. Platinum resistance

thermometers positioned in inlet and return gas streams at the refrigerator manifold were calibrated to provide specimen temperature control within  $\pm 0.5$  K.

Measurement of neutron fluence. - The fast neutron spectrum in the test location in HB-2 was determined using foil measurement techniques. Sets of foils, as shown in table II, were irradiated and then counted and evaluated by standard techniques. From these data and the reactor operating conditions at the time of foil exposure, the fast neutron fluence, with energy greater than 0.5 MeV ( $E > 0.5$  MeV (80 fJ)), was determined. Periodic measurements throughout the life of a reactor power cycle were performed to establish the neutron flux as a function of control rod position. During test program performance, the exposure rate for test specimens varied from about  $2.0 \times 10^{12}$  to  $2.5 \times 10^{12}$  neutrons per square centimeter per second. (The ratio of the fluence with neutron energy greater than E to the fluences with energies greater than 0.5 MeV (80 fJ) is given in Figure 4. This figure is based on 27 sets of foils irradiated during the test program.)

Stress-strain recording. - The load applied to the test specimen was monitored by a proving ring type dynamometer using a linear variable differential transformer (LVDT) to measure the ring deflection resulting from loading. Dynamometers in each test loop were calibrated to within two percent of a National Bureau of Standards certified reed type proving ring. Strain was



measured using an extensometer which measured the increase of the separation between two knife edges initially 0.5-inch (1.27-cm) apart. The measurement was accomplished through the use of a LVDT specially constructed to be resistant to radiation effects. This extensometer had a range of reliable accuracy of approximately 0.01-inch (0.025-cm), which was sufficient to record strains to well beyond the yield strength (0.2 percent offset method). The extensometer was verified in accordance with ASTM Specification E83 (Ref. 20) and the error in indicated strain was less than 0.0001. Installation of the extensometer by remote means, however, introduces the possibility for increased error in the indicated strain. An X-Y recorder was employed to automatically plot the load-strain curve to approximately 0.02 total strain. The X-axis recorder was then switched to time travel and a load-time curve through fracture was obtained.

Ductility measurements. - After removal from the test loop, the fractured gage length and minimum diameter were measured. The broken halves of the test specimens were fit together and measurements were obtained by means of a micrometer stage and hairline apparatus accurate to  $\pm 0.0001$  inch (0.00025 cm).

Data reduction and analysis. - The load-strain/load-time curve developed by the X-Y recorder during testing and the initial specimen dimensions provided data for the determination of the ultimate tensile strength and the tensile yield strength (0.2

percent offset method). The modulus of elasticity was also approximated from these curves. Elongation and reduction of area values were calculated from the original specimen dimensions and the dimensions following fracture. The test data were compiled and subjected to statistical analysis in accordance with various methods given by Natrella (Ref. 21). These analyses included determination of average values and estimated standard deviations for each material and test condition; determining the differences between values for irradiated and unirradiated test conditions, and the 95 percent confidence interval associated with these differences and estimation, of the following irradiation.

### TEST RESULTS

Tensile test data obtained during performance of the data acquisition phase of the test program are compiled in tables III through X of the appendix. Summaries of the statistical analyses performed in connection with data analyses are also included in the tables.

#### Commercially Pure Titanium

Some CP Ti was employed as test material for investigating the synergistic effect of reactor irradiation and cryogenic temperature on the tensile properties. The objective of this investigation was to determine the radiation damage threshold - that is, the fluence level at which significant changes in tensile properties occurred - and to study the reduction of this damage during post-

irradiation annealing.

Radiation damage threshold. - The radiation damage threshold was determined from tests conducted at 17 K following reactor irradiation at 17 K to fluence levels of  $1 \times 10^{17}$ ,  $6 \times 10^{17}$ , and  $10 \times 10^{17}$  neutrons per square centimeter,  $E > 0.5$  MeV (80 fJ). Tests conducted at 17 K on unirradiated material were used as base line control data. Results of the data analyses are shown in Figure 5 where it can be seen that the irradiation increased strength parameters, decreased ductility parameters, but did not alter the tensile modulus of elasticity. The increases in yield and ultimate strengths are approximately linear with increasing fluence with the yield strength increasing more rapidly than the ultimate strength, as may be observed from the plot of yield-to-ultimate-strength ratio. The changes in total elongation and reduction of area are small and in most cases are not statistically significant at the 0.05 level of significance. (In order for the difference to be statistically significant at the 0.05 level of significance, the 95 percent confidence interval must not include zero.) Only the increase in the reduction of area following  $1 \times 10^{17}$  neutrons per square centimeter exposure and the decrease in total elongation following  $6 \times 10^{17}$  neutrons per square centimeter exposure are statistically significant.

The general data trend for irradiations to  $10 \times 10^{17}$  neutrons per square centimeter at 17 K indicates that the radiation damage

threshold occurs in the region between  $1 \times 10^{17}$  and  $6 \times 10^{17}$  neutrons per square centimeter. This threshold is defined by a significant increase in both yield strength and ultimate strength and possibly a small decrease in ductility. The increase in reduction of area following irradiation to  $1 \times 10^{17}$  neutrons per square centimeter appears to be anomalous.

Reduction of radiation damage. - The reduction of radiation damage was investigated using heat treatments following irradiation at 17 K to  $6 \times 10^{17}$  neutrons per square centimeter. Unirradiated specimens were subjected to the same heat treatment conditions except for the time of initial 17 K exposure. The unirradiated specimens were held for 1 hour at 17 K prior to heat treatment, whereas the irradiated specimens were held approximately 40 hours (irradiation time) at 17 K prior to heat treatment.

Two cases are considered to be pertinent to the reduction of radiation damage. The first case consists of simply warming the specimen from 17 K to a higher temperature and then testing at this higher temperature. This provides information relative to the reduction of the irradiation induced defects influence on the metal lattice, but does not separate the annihilation of defects from the reduction in lattice friction due to higher thermal oscillation of lattice ions. The second case, defined as annealing, duplicated the previous warming condition, but specimen temperatures were subsequently reduced to and held for 1 hour at 17 K

prior to testing at 17 K. The combination of these two cases permits a separation of defect annihilation from defect resistance. The results of data analyses are shown in Figure 6.

As can be seen from the dashed curves of Figure 6, warming the specimens from 17 to 178 K resulted in a recovery of approximately one-half of the radiation damage for the yield strength and three-fourths for the ultimate strength. The greater portion of this recovery occurred between 17 and 78 K. The reduction of area and tensile modulus of elasticity are not significantly different at 178 K than at 17 K although the trend for the reduction of area does indicate some damage at 17 K which has fully recovered at 178 K. The total elongation indicates further damage at 78 K; however, the 95 percent confidence intervals for this property overlap at all temperatures, suggesting an equal probability that the indicated trend is within material variability limits.

Annealing the test material resulted in essentially the same recovery as observed for the warming case, as may be noted from the solid curves of Figure 6. The ultimate strength following 178 K annealing appears somewhat higher than the corresponding 178 K warming case; however, the 95 percent confidence interval is also greater and includes the confidence interval for the warming case. Such a condition suggests that there is no difference between the two thermally cycled conditions. This conclusion is somewhat shadowed, however, by the distinct separation of the

confidence intervals for the yield- to ultimate-strength ratio following thermal treatment at 178 K. The results for total elongation following the 78 K treatment and the reduction of area following the 78 and 178 K treatments show some deviations; however, for each case there is an overlap of the 95 percent confidence intervals which indicates no significant differences.

The data compared in Figure 6 lead to the conclusion that thermally cycling CP Ti to 178 K following irradiation at 17 K to  $6 \times 10^{17}$  neutrons per square centimeter reduces the irradiation damage by annihilation of irradiation-induced defects. As a result of this annihilation, the irradiation damage to the yield and ultimate strengths is reduced by about 50 percent. Furthermore, for the ultimate strength, there is an indication that additional recovery, attributable to reduced lattice resistance, occurs between 78 and 178 K.

#### Titanium - 5 Aluminum - 2.5 Tin Alloy

The titanium alloy containing 5 percent aluminum and 2.5 percent tin (Ti-5Al-2.5Sn) was employed as test material for investigating the influence of impurity elements on radiation damage at cryogenic temperature. Two heats of the alloy (table I), one having the normal level of impurity content and one having an extra low level of impurity content, were used.

Tests using each material were conducted at 17 K following reactor irradiation at 17 K to  $1 \times 10^{17}$  and  $10 \times 10^{17}$  neutrons per

square centimeter. Tests conducted at 17 K on unirradiated materials were used as base line control data. Results of the data analyses are shown in Figure 7.

Radiation damage threshold. - As may be seen from the solid curves of Figure 7, irradiation of the normal impurity material at 17 K to  $10 \times 10^{17}$  neutrons per square centimeter increased the yield and ultimate strengths, with the yield strength increasing more rapidly than the ultimate strength as evidenced by the plot of yield- to ultimate-strength ratio. The total elongation was decreased slightly by the irradiation, while the reduction of area and tensile modulus of elasticity remained unchanged. These data indicate that the threshold for radiation damage at 17 K occurs prior to  $1 \times 10^{17}$  neutrons per square centimeter as evidenced by the marked increases in yield and ultimate strengths.

Irradiation of the extra low impurity material at 17 K to  $10 \times 10^{17}$  neutrons per square centimeter caused essentially the same changes in 17 K tensile properties (dashed curves shown in Fig. 7) with the exception of the reduction of area. The reduction of area shows a significant decrease following irradiation to  $10 \times 10^{17}$  neutrons per square centimeter. It should be noted also that following irradiation to  $1 \times 10^{17}$  neutrons per square centimeter the tensile modulus of elasticity decreased. This decrease is small, but it is statistically significant at the 0.05 level of significance. The threshold for radiation damage is higher than the normal

impurity material and occurs in the interval between  $1 \times 10^{17}$  and  $10 \times 10^{17}$  neutrons per square centimeter.

Influence of impurity elements on radiation damage. - As for the effects of impurity elements on radiation damage, Figure 7 shows that in every case there is an overlap of the 95 percent confidence intervals and in most cases the overlapped regions include the mean values for both normal impurity and extra low impurity materials. Notable exceptions occur for yield and ultimate strengths following  $1 \times 10^{17}$  neutrons per square centimeter. Here the 95-percent confidence intervals do overlap, but the difference in mean values of the yield and ultimate strengths for the two materials do not fall within the overlapped intervals. It would be presumptuous to conclude from these data that there is a difference in the radiation damage attributable to impurity content except possibly for the yield and ultimate strengths following  $1 \times 10^{17}$  neutrons per square centimeter exposure.

#### Titanium - 6 Aluminum - 4 Vanadium Alloy

Two heats of the titanium alloy containing 6 percent aluminum and 4 percent vanadium (Ti-6Al-4V) were used for cryogenic irradiation studies. One heat of the material was in the annealed condition, while the second heat of material was solution treated then aged.

Tests using each heat of material were conducted at 17 K following reactor irradiation at 17 K to  $1 \times 10^{17}$  and  $10 \times 10^{17}$  neutrons



per square centimeter. Tests conducted at 17 K on unirradiated materials were used as base line control data. Results of data analysis are shown on Figure 8.

Radiation damage threshold. - As may be seen from Figure 8, with the exception of the reduction of area, there is little difference in the irradiation effect on annealed material and aged material. For both material conditions the radiation damage threshold occurs for exposures less than  $1 \times 10^{17}$  neutrons per square centimeter, as evidenced by increases in yield and ultimate strengths, a decrease in total elongation, and changes in the reduction of area. The decreases in total elongation are small; however, they are statistically significant at the 0.05 level of significance.

The reduction of area shows the irradiation of annealed material causes an increase, whereas irradiation of the aged material causes a decrease. The 95 percent confidence intervals are approximately equal for all differences. Following irradiation to  $1 \times 10^{17}$  and  $10 \times 10^{17}$  neutrons per square centimeter, these confidence intervals do not overlap, which indicates that there is a difference in the effect of irradiation at 17 K on annealed material and aged material.

The difference indicated by the tensile modulus of elasticity is probably exaggerated since the variability of the annealed material following irradiation to  $10 \times 10^{17}$  neutrons per square centi-

meter is unusually large and data from only one specimen for each temper condition were obtained following irradiation to  $1 \times 10^{17}$  neutrons per square centimeter.

From these data, the only indication that metallurgical condition influences radiation damage at 17 K is a small difference in the reduction of area following exposure to  $10 \times 10^{17}$  neutrons per square centimeter. This difference represents a decrease in the ductility of aged material which is not evident in the annealed material.

#### Titanium - 8 Aluminum - 1 Molybdenum - 1 Vanadium Alloy

The titanium alloy containing 8 percent aluminum, 1 percent molybdenum, and 1 percent vanadium (Ti-8Al-1Mo-1V) was irradiated at 17 K to a fluence of  $1 \times 10^{17}$  neutrons per square centimeter to determine the threshold for radiation damage. Tests conducted at 17 K on unirradiated material were used as baseline control data. Results of data analyses are shown in Figure 9 where it can be seen that the threshold for radiation damage at 17 K occurs for exposures less than  $1 \times 10^{17}$  neutrons per square centimeter, as evidenced by the increase in both yield and ultimate strengths. The total elongation following this exposure appears to decrease; however, the decrease is small and not statistically significant at the 0.05 level of significance. The indicated increase in the tensile modulus of elasticity is subject to considerable uncertainty since it is based on only two irradiated specimen

values, both of which appear to be unusually high. The irradiated values and the unusually large 95 percent confidence interval are most probably due to test techniques rather than irradiation.

#### Comparison of Radiation Damage to Titanium-Base Alloys

The effect of reactor irradiation at 17 K on 17 K tensile properties of CP Ti and the three titanium-base alloys is shown in Figure 10. The points plotted on this figure are the differences in the mean values of each tensile property for each alloy and alloy condition. The curves for Ti-5Al-2.5Sn are the average for normal impurity and extra low impurity heats of material. The curves for Ti-6Al-4V are the average for annealed and aged conditions (with the exception of reduction of area, where curves representing the two material conditions are shown).

The comparisons of Figure 10 show that irradiation at 17 K to  $10 \times 10^{17}$  neutrons per square centimeter causes similar changes in the 17 K tensile properties of all alloys. Tensile strengths increase (with the yield strength increasing more than the ultimate strength) and ductilities decrease slightly. There is also an indication that the magnitude of the change due to irradiation depends on total alloy content or metallurgical structure.

#### SUMMARY OF RESULTS AND CONCLUSIONS

Commercially pure titanium and three titanium-base alloys have been subjected to reactor irradiation at 17 K for fluence levels up to  $10 \times 10^{17}$  neutrons per square centimeter ( $E > 0.5$  MeV

(80 fJ)). Post-irradiation tensile tests were conducted at 17 K without intervening warmup, except for a few tests using CP Ti. Test results show the following:

1. The irradiation damage threshold at 17 K for CP Ti occurs in the region between  $1 \times 10^{17}$  and  $6 \times 10^{17}$  neutrons per square centimeter. This threshold is defined by a significant increase in both yield strength and ultimate strength and possibly a small decrease in ductility.

2. Thermally cycling CP Ti to 178 K following irradiation at 17 K to  $6 \times 10^{17}$  neutrons per square centimeter reduces the irradiation damage by annihilation of irradiation-induced defects. As a result of this annihilation, the irradiation damage to the yield and ultimate strengths is reduced by about 50 percent. Furthermore, for the ultimate strength, there is an indication that additional recovery, attributable to reduced lattice resistance, occurs between 78 and 178 K.

3. The threshold for radiation damage at 17 K of Ti-5Al-2.5Sn alloy with normal impurity content occurs for exposures less than  $1 \times 10^{17}$  neutrons per square centimeter. For the same alloy with extra low impurity content, the threshold for radiation damage at 17 K is higher than the normal impurity material and occurs in the interval between  $1 \times 10^{17}$  and  $10 \times 10^{17}$  neutrons per square centimeter. These thresholds are indicated by significant increases in both yield and ultimate strengths and decreases in ductility.

The differences in radiation damage thresholds shown by the Ti-5Al-2.5Sn alloys may be due to material variability.

4. The irradiation damage threshold at 17 K for Ti-6Al-4V alloy occurs for exposures less than  $1 \times 10^{17}$  neutrons per square centimeter. The threshold is evidenced by significant increases in yield and ultimate strengths and decreases in ductility parameters. Differences in the reduction of area following irradiation are the only indications that the heat-treated condition influences the irradiation effect.

5. The irradiation damage threshold at 17 K for the Ti-8Al-1Mo-1V alloy occurs for exposures less than  $1 \times 10^{17}$  neutrons per square centimeter. This threshold is indicated by significant increases in both the yield and ultimate strengths and probable decrease in ductility.

6. The effect of reactor irradiation at 17 K on 17 K tensile properties of CP Ti and the three titanium-base alloys investigated are similar. Irradiation damage is evidenced by significant increases in strength parameters and probable decreases in ductility parameters. The magnitude of radiation damage appears to depend on the total alloy content or metallurgical structure.

APPENDIX - TABULATED TEST DATA AND SUMMARY  
OF STATISTICAL ANALYSES

Tensile test data obtained during performance of the data acquisition phase of the program are compiled in tables III to X. Summaries of the statistical analyses performed in connection with data analyses are also included in the tables. Symbols used on the tables for statistical analysis are defined as follows:

$$\bar{X}_A = \frac{1}{n_A} \sum_{i=1}^n X_i$$

arithmetic mean of  $n_A$   
measurements yielding  
property values of  
 $X_1, X_2, \dots$

$$s_A = \sqrt{\frac{\sum_{i=1}^n (X_i - \bar{X}_A)^2}{n_A - 1}}$$

estimated standard deviation of  $n_A$  measurements yielding property values of  $X_1, X_2, \dots$

$$X_L = (\bar{X}_B - \bar{X}_A) - u_A$$

or

$$(\bar{X}_B - \bar{X}_A) - u_{BA}$$

lower limit of the 95-percent confidence interval of the difference between arithmetic means

$$\bar{X}_U = (\bar{X}_A - \bar{X}_A) + u_A$$

or

$$(\bar{X}_B - \bar{X}_A) + u_{BA}$$

$$u_A = (t_{0.975}) \frac{s_A}{\sqrt{n_A}}$$

$$u_{BA} = (t_{0.975}) \sqrt{\frac{s_A^2}{n_A} + \frac{s_B^2}{n_B}}$$

$t_{0.975}$

upper limit of 95-percent  
confidence interval of  
difference between  
arithmetic means

for  $n_A - 1$  degrees of  
freedom

$$\text{for } \frac{\left(\frac{s_A^2}{n_A} + \frac{s_B^2}{n_B}\right)^2}{\frac{(s_A^2/n_A)^2}{n_A + 1} + \frac{(s_B^2/n_B)^2}{n_B + 1}} - 2$$

effective number of degrees  
of freedom

distribution value for "t"

test of significance

(e.g., Ref. 21, table A-4)

## REFERENCES

1. Schwartzberg, F. R.; Osgood, S. H.; Keys, R. D.; and Kiefer, T. F., "Cryogenic Materials Data Handbook," AFML-TDR-64-280, DDC No. AD-609562, Martin Co., 1964.
2. Makin, M. J. and Minter, F. J., "The Effect of Neutron Irradiation on the Mechanical Properties of Titanium and Zirconium," Journal, Inst. Metals, Vol. 85, 1956-1957, pp. 397-402.
3. Eckel, J. F.; Bruch, C. A.; Levy, A.; Willis, A. H.; and Seymour, W. E., "Radiation Effects on Reactor Materials - A Review of KAPL Work," Radiation Effects Review Meeting, Congress Hotel, Chicago, Ill., July 31-Aug. 1, 1956, AEC Report TID-7515 (Part 2)(Del.), 1956, pp. 170-221.
4. Bruch, C. A.; McHugh, W. E.; and Hockenbury, R. W., "Variations in Radiation Damage to Metals," Transactions, Am. Inst. Met. Eng., Vol. 206, 1956, pp. 1362-1372.
5. Anderson, W. K.; Beck, C. J.; Kephart, A. R.; and Theilacker, J. S., Reactor Structural Materials: Engineering Properties as Affected by Nuclear Reactor Service, ASTM STP 314, Am. Soc. Testing Mats., 1962. (Data reported by C. A. Bruch and W. E. McHugh, "Radiation Damage Studies of Seven Nonfissionable Metals," Paper 58-NESC-37, AIChE Nuclear Engineering and Scientific Conference, Chicago, Ill., Mar. 17-21, 1958.)



6. Bomar, E. S.; Cooke, F. W.; Leonard, W. J.; Prislinger, J. J.; and Wodtke, C. H.; "Engineering Metallurgy," Metallurgy Division Annual Progress Report for Period Ending September 1, 1959, ORNL-2839, Union Carbide Corp., 1959, pp. 127-143.
7. Adamson, G. M.; "Metallurgy - Mechanical Metallurgy - Tensile Properties of Irradiated Titanium Alloys," Homogeneous Reactor Program Quarterly Progress Report for Period Ending October 31, 1957, ORNL-2432, Union Carbide Corp., 1958, pp. 135-136.
8. Lombardo, J. J.; Dixon, C. E.; and Begley, J. A., "Cryogenic Radiation Effects on NERVA Structural Materials," Effects of Radiation on Structural Metals, ASTM STP 426, Am. Soc. Testing Mats., 1967, pp. 625-652.
9. Watson, J. F.; Christian, J. L.; and Allen, J. W., "A Study of the Effects of Nuclear Radiation on High-Strength Aerospace Vehicle Materials at the Boiling Point of Hydrogen (-423° F)," ERR-AN-085, General Dynamics/Astronautics, 1961.
10. Shogan, R. P., "Tensile Properties of Irradiated Ti-5% Al-2.5% Sn ELI at Cryogenic Temperatures," WANL-TME-1860, Westinghouse Astronuclear Lab., 1968
11. Drennan, J. E. and Hamman, D. J., "Supplemental Analysis of GTR-19 Data," BMI-NRE-10, Battelle Memorial Inst., 1968.

12. Wallack, S., "The Effect of Radiation on the Physical and Mechanical Properties of Metals and Alloys," WADC TR 58-605, DDC No. AD-215540, Universal Winding Co., Inc., 1959.
13. Anon., Tentative Recommended Practice for Measuring Neutron Flux Environment for Reactor Irradiated Specimens. ASTM Designation: E199-62T. 1962 Supplement to Book of ASTM Standards, Part 3, Methods of Testing Metals (Except Chemical Analysis). ASTM, 1962, pp. 72-85.
14. Anon., Tentative Methods of Tension Testing of Metallic Materials. ASTM Designation: E8-61T. 1961 Book of ASTM Standard, Part 3, Methods of Testing Metals (Except Chemical Analysis). ASTM, 1961, pp. 165-181.
15. Anon., Recommended Practice for Effect of High-Energy Radiation on the Tensile and Impact Properties of Metallic Materials. ASTM Designation: E184-62. 1962 Supplement to Book of ASTM Standards, Part 3, Methods of Testing Metals (Except Chemical Analysis). ASTM, 1962, pp. 29-33.
16. Younger, C. L. and Haley, F. A., "Effect of Nuclear Radiation at Cryogenic Temperatures on the Tensile Properties of Titanium and Titanium-Base Alloys," NASA TN D-5442, Nat. Aeronautics and Space Administration, 1969.

17. Bridges, W. L. and Liebschutz, A. M., "Tension-Compression-Shear Loop for Irradiation Testing at Cryogenic Temperatures," Advances in Cryogenic Engineering, Vol. 7 (K. D. Timmerhaus, ed.), Plenum Press, New York, N. Y., 1962, pp. 440-447.
18. Aseff, G. V., Sr.; Callaway, R. F.; and Liebschutz, A. M., "Tensile, Compression, and Shear Loop for Irradiation Testing at Cryogenic Temperatures," Advances in Cryogenic Engineering, Vol. 8 (K. D. Timmerhaus, ed.), Plenum Press, New York, N. Y., 1963, pp. 624-630.
19. Liebschutz, A. M. and Schulte, C. A., "In-Pile Loop Cryogenic Refrigerator," Advances in Cryogenic Engineering, Vol. 7 (K. D. Timmerhaus, ed.), Plenum Press, New York, N. Y., 1962, pp. 181-188.
20. Anon., Tentative Method of Verification and Classification of Extensometers. ASTM Designation: E-83-57T. 1961 Book of ASTM Standards, Part 3, Methods of Testing Metals (Except Chemical Analysis). ASTM, 1961, pp. 202-209.
21. Natrella, M. G., "Experimental Statistics," Handbook 91, Nat. Bureau of Standards, 1963.

TABLE I. - CHEMICAL COMPOSITION AND FABRICATION HISTORY OF TEST MATERIALS

Test material	Temper	Heat treatment <sup>a</sup>	Chemical composition by weight percent <sup>b</sup>										
			Titanium	Aluminum	Tin	Vanadium	Molybdenum	Iron	Carbon	Nitrogen	Oxygen	Hydrogen	
Commercially pure titanium	Annealed	A	Balance	----	----	----	----	----	0.190	0.032	0.023	0.218	0.006
Titanium - 5 aluminum - 2.5 tin, NI	Annealed	B	↓	5.10	2.47	----	----	----	.110	.032	.019	.116	.012
Titanium - 5 aluminum - 2.5 tin, ELI	Annealed	B		5.36	2.35	----	----	----	.025	.022	.010	.059	.006
Titanium - 6 aluminum - 4 vanadium	Annealed	A		5.95	----	4.00	----	----	.170	.010	.022	.065	.006
Titanium - 6 aluminum - 4 vanadium	Aged	C		5.80	----	3.90	----	----	.150	.010	.035	.102	.010
Titanium - 8 aluminum - 1 molybdenum - 1 vanadium	Duplex annealed	D		8.02	----	1.14	1.00	----	.120	.030	.013	.091	.009

<sup>a</sup>Heat treatment:

A - Annealed at 978 K for 2 hr, air cooled.

B - Annealed at 1033 K for 2 hr, air cooled.

C - Solution treated at 1214 K for 0.5 hr, water quenched; aged at 811 K for 4 hr, air cooled.

D - Annealed at 1172 K for 1 hr, air cooled; annealed at 867 K for 8 hr, air cooled.

<sup>b</sup>Actual analyses on as-received bar.

TABLE II. - FOILS USED FOR SPECTRAL MEASUREMENTS OF FAST NEUTRON FLUENCE IN HB-2

Type of foil	Nuclear reaction	Threshold energy		Cross section, cm <sup>2</sup>
		MeV	fJ	
Indium	In <sup>115</sup> (neutron, neutron) In <sup>115m</sup>	0.45	72	0.20×10 <sup>-24</sup>
Neptunium	Np <sup>237</sup> (neutron, fission) Ba <sup>140</sup>	.75	120	1.52
Uranium	U <sup>238</sup> (neutron, fission) Ba <sup>140</sup>	1.45	232	.54
Thorium	Th <sup>232</sup> (neutron, fission) Ba <sup>140</sup>	1.75	280	<sup>a</sup> .10
Sulfur	S <sup>32</sup> (neutron, proton) P <sup>32</sup>	2.9	464	.284
Nickel	Ni <sup>58</sup> (neutron, proton) Co <sup>58</sup>	5.0	800	1.67
Magnesium	Mg <sup>24</sup> (neutron, proton) Na <sup>24</sup>	6.3	1008	.0715
Aluminum <sup>b</sup>	Al <sup>27</sup> (neutron, alpha) Na <sup>24</sup>	8.1	1296	.110
Aluminum	Al <sup>27</sup> (neutron, alpha) Na <sup>24</sup>	8.6	1376	.23

<sup>a</sup>Cross section for thorium is not considered reliable.

<sup>b</sup>Al<sup>27</sup> (neutron, proton) Mg<sup>27</sup> reaction with a threshold energy of 5.3 MeV (848 fJ) is not included because of short (9.8 min) half life of product.

TABLE III. - EFFECT OF REACTOR IRRADIATION AT 17 K ON 17 K TENSILE PROPERTIES  
OF COMMERCIALY PURE TITANIUM<sup>a</sup>

Specimen	Fast fluence, neutrons/cm <sup>2</sup> (b)	Statistical analysis (c)	Tensile modulus of elasticity		Yield strength (0.2-percent offset)		Ultimate strength		Yield- to ultimate-strength ratio	Total elongation, percent (d)	Reduction of area, percent	
			lb/in. <sup>2</sup>	N/m <sup>2</sup>	lb/in. <sup>2</sup>	N/m <sup>2</sup>	lb/in. <sup>2</sup>	N/m <sup>2</sup>				
1Aa211	0	-----	19.0×10 <sup>6</sup>	13.1×10 <sup>10</sup>	126.0×10 <sup>3</sup>	86.8×10 <sup>7</sup>	185.0×10 <sup>3</sup>	127.5×10 <sup>7</sup>	0.681	32.0	44.0	
1Aa3	0	-----	18.0	12.4	131.0	90.3	182.0	125.4	.719	31.0	48.0	
1Aa2	0	-----	19.0	13.1	134.0	92.3	188.0	129.5	.712	30.0	47.0	
			$\bar{X}_A$	18.7×10 <sup>6</sup>	12.9×10 <sup>10</sup>	130.3×10 <sup>3</sup>	89.8×10 <sup>7</sup>	185.0×10 <sup>3</sup>	127.5×10 <sup>7</sup>	0.704	31.0	46.3
			$s_A$	.6	.4	4.1	2.8	3.0	2.1	.020	1.0	2.1
			$\bar{X}_B - \bar{X}_A$	0	0	0	0	0	0	0	0	0
			$X_L$	-1.5	-1.0	-10.2	-7.0	-7.4	-5.1	-.050	-2.5	-5.2
			$X_U$	1.5	1.0	10.2	7.0	7.4	5.1	.050	2.5	5.2
1Aa138	1×10 <sup>17</sup>	-----	18.4×10 <sup>6</sup>	12.7×10 <sup>10</sup>	128.0×10 <sup>3</sup>	88.2×10 <sup>7</sup>	181.0×10 <sup>3</sup>	124.7×10 <sup>7</sup>	0.706	---	---	
1Aa148	1	-----	18.5	12.7	131.0	90.3	180.0	124.0	.728	36.0	54.0	
1Aa144	1	-----	21.4	14.7	136.0	93.7	187.0	128.8	.726	32.0	52.0	
			$\bar{X}_B$	19.4×10 <sup>6</sup>	13.4×10 <sup>10</sup>	131.7×10 <sup>3</sup>	90.7×10 <sup>7</sup>	182.7×10 <sup>3</sup>	125.9×10 <sup>7</sup>	0.720	34.0	53.0
			$s_B$	1.7	1.2	4.0	2.8	3.7	2.6	.012	2.8	1.4
			$\bar{X}_B - \bar{X}_A$	.7	.5	1.4	.9	-2.3	-1.6	.016	3.0	6.7
			$X_L$	-2.6	-1.8	-6.7	-4.6	-9.4	-6.5	-.020	-5.9	2.7
			$X_U$	4.0	2.8	9.5	6.5	4.8	3.3	.052	11.9	10.7
			$e_{s_B}^2/s_A^2$	8.03	9.00	.95	1.00	1.52	1.53	.36	7.84	.44
1Aa200	6×10 <sup>17</sup>	-----	20.0×10 <sup>6</sup>	13.8×10 <sup>10</sup>	154.0×10 <sup>3</sup>	106.1×10 <sup>7</sup>	203.0×10 <sup>3</sup>	139.9×10 <sup>7</sup>	0.757	29.0	45.0	
1Aa153	6	-----	15.0	10.3	154.0	106.1	211.0	145.4	.729	27.0	38.0	
1Aa203	6	-----	19.0	13.1	158.0	108.9	204.0	140.6	.773	29.0	46.0	
			$\bar{X}_C$	18.0×10 <sup>6</sup>	12.4×10 <sup>10</sup>	155.3×10 <sup>3</sup>	107.0×10 <sup>7</sup>	206.0×10 <sup>3</sup>	142.0×10 <sup>7</sup>	0.753	28.3	43.0
			$s_C$	2.6	1.8	2.3	1.6	4.4	3.0	.022	1.2	4.4
			$\bar{X}_C - \bar{X}_A$	-.7	-.5	25.0	17.2	21.0	14.5	.049	-2.7	-3.3
			$X_L$	-7.3	-5.1	17.5	12.1	13.4	9.2	.007	-4.9	-11.1
			$X_U$	5.9	4.1	32.5	22.4	29.2	20.2	.091	-.5	4.5
			$e_{s_C}^2/s_A^2$	18.78	22.56	.31	.32	2.15	2.02	1.21	1.44	4.38
1Aa152	10×10 <sup>17</sup>	-----	14.2×10 <sup>6</sup>	9.8×10 <sup>10</sup>	159.0×10 <sup>3</sup>	109.6×10 <sup>7</sup>	213.0×10 <sup>3</sup>	146.8×10 <sup>7</sup>	0.746	30.0	49.0	
1Aa205	10	-----	22.2	15.3	171.0	117.8	216.0	148.8	.791	29.0	44.0	
1Aa206	10	-----	---	---	181.0	124.7	223.0	153.6	.811	19.0	38.0	
			$\bar{X}_D$	18.2×10 <sup>6</sup>	12.5×10 <sup>10</sup>	170.3×10 <sup>3</sup>	117.4×10 <sup>7</sup>	217.3×10 <sup>3</sup>	149.7×10 <sup>7</sup>	0.783	26.0	43.7
			$s_D$	5.7	3.9	11.0	7.6	5.1	3.5	.033	6.1	5.5
			$\bar{X}_D - \bar{X}_A$	-.5	-.4	40.0	27.6	32.3	22.2	.079	-5.0	-2.6
			$X_L$	<sup>f</sup> -52.0	<sup>f</sup> -35.9	18.4	12.7	23.1	15.9	.022	-20.4	-13.4
			$X_U$	51.0	35.1	61.6	42.4	42.1	29.0	.136	10.4	8.2
			$e_{s_D}^2/s_A^2$	90.25	95.06	7.19	7.36	2.89	2.78	2.72	37.21	6.85

<sup>a</sup> Specimen exposed in gaseous helium and maintained at 17 K throughout test.

<sup>b</sup> Fast fluence is for E > 0.5 MeV (80 fJ).

<sup>c</sup> Arithmetic mean  $\bar{X}$ ; estimated standard deviation s; lower and upper limits of 95 percent confidence interval of the difference,  $X_L$ ,  $X_U$ .

<sup>d</sup> Total elongation in 0.5-in. (1.27-cm) gage length.

<sup>e</sup> Values for tensile modulus of elasticity, yield strength, and ultimate strength differ because of significant figures maintained in comparative calculations between the two systems of units.

<sup>f</sup> Value exceeds lower limit of possible change.

TABLE IV. - EFFECT OF WARMING FOLLOWING REACTOR IRRADIATION AT 17 K ON

TENSILE PROPERTIES OF COMMERCIALY PURE TITANIUM<sup>a</sup>

Specimen	Fast fluence, neutrons/cm <sup>2</sup> (b)	Test temperature, K (c)	Statistical analysis (d)	Tensile modulus of elasticity		Yield strength (0.2-percent offset)		Ultimate strength		Yield- to ultimate-strength ratio	Total elongation, percent (e)	Reduction of area, percent
				lb/in. <sup>2</sup>	N/m <sup>2</sup>	lb/in. <sup>2</sup>	N/m <sup>2</sup>	lb/in. <sup>2</sup>	N/m <sup>2</sup>			
1Aa201	0	78	-----	20.0×10 <sup>6</sup>	13.8×10 <sup>10</sup>	103.0×10 <sup>3</sup>	71.0×10 <sup>7</sup>	134.0×10 <sup>3</sup>	92.3×10 <sup>7</sup>	0.768	52.0	66.0
1Aa195	0	78	-----	17.0	11.7	106.0	73.0	137.0	94.4	.773	51.0	68.0
1Aa11	0	78	-----	18.0	12.4	106.0	73.0	138.0	95.1	.767	47.0	67.0
			$\bar{X}_E$	18.3×10 <sup>6</sup>	12.6×10 <sup>10</sup>	105.0×10 <sup>3</sup>	72.3×10 <sup>7</sup>	136.4×10 <sup>3</sup>	93.9×10 <sup>7</sup>	0.769	50.0	67.0
			$s_E$	1.5	1.0	1.7	1.2	2.1	1.5	.003	2.6	1.0
1Aa212	6×10 <sup>17</sup>	78	-----	18.0×10 <sup>6</sup>	12.4×10 <sup>10</sup>	116.0×10 <sup>3</sup>	79.9×10 <sup>7</sup>	145.0×10 <sup>3</sup>	99.9×10 <sup>7</sup>	0.800	43.0	63.0
1Aa1	6	78	-----	19.0	13.1	120.0	82.7	145.0	99.9	.827	39.0	66.0
1Aa42	6	78	-----	20.0	13.8	126.0	86.8	147.0	101.3	.857	41.0	63.0
			$\bar{X}_F$	19.0×10 <sup>6</sup>	13.1×10 <sup>10</sup>	120.6×10 <sup>3</sup>	83.1×10 <sup>7</sup>	145.7×10 <sup>3</sup>	100.4×10 <sup>7</sup>	0.828	41.0	64.0
			$s_F$	1.0	.7	5.0	3.4	1.2	.8	.029	2.0	1.7
			$\bar{X}_F - \bar{X}_E$	.7	.5	15.6	10.7	9.3	6.5	.059	-9.0	-3.0
			$X_L$	-2.0	-1.4	5.9	4.1	5.4	3.7	-.014	-13.6	-6.2
			$X_U$	3.4	2.3	25.3	17.4	13.2	9.1	.132	-4.4	.2
			$f s_F^2 / s_E^2$	.44	.49	8.64	8.02	.33	.27	93.44	.59	2.89
1Aa59	0	178	-----	17.0×10 <sup>6</sup>	11.7×10 <sup>10</sup>	76.9×10 <sup>3</sup>	53.0×10 <sup>7</sup>	94.2×10 <sup>3</sup>	64.9×10 <sup>7</sup>	0.817	30.0	64.0
1Aa51	0	178	-----	21.0	14.5	78.9	54.4	94.3	65.0	.837	26.0	62.0
1Aa17	0	178	-----	15.0	10.3	79.9	55.1	95.2	65.6	.839	35.0	61.0
			$\bar{X}_G$	17.7×10 <sup>6</sup>	12.2×10 <sup>10</sup>	78.6×10 <sup>3</sup>	54.2×10 <sup>7</sup>	94.6×10 <sup>3</sup>	65.2×10 <sup>7</sup>	0.831	30.3	62.3
			$s_G$	3.1	2.1	1.5	1.1	.6	.4	.012	4.5	1.5
1Aa23	6×10 <sup>17</sup>	178	-----	17.0×10 <sup>6</sup>	11.7×10 <sup>10</sup>	90.7×10 <sup>3</sup>	62.5×10 <sup>7</sup>	101.0×10 <sup>3</sup>	69.6×10 <sup>7</sup>	0.897	25.0	64.0
1Aa45	6	178	-----	18.0	12.4	92.6	63.8	100.0	68.9	.926	30.0	64.0
1Aa35	6	178	-----	20.0	13.8	92.7	63.9	101.0	69.6	.917	29.0	63.0
			$\bar{X}_H$	18.3×10 <sup>6</sup>	12.6×10 <sup>10</sup>	92.0×10 <sup>3</sup>	63.4×10 <sup>7</sup>	100.7×10 <sup>3</sup>	69.4×10 <sup>7</sup>	0.913	28.0	63.7
			$s_H$	1.5	1.0	1.1	.8	.6	.4	.015	2.6	.6
			$\bar{X}_A - \bar{X}_G$	.6	.4	13.4	9.2	6.1	4.2	.082	-2.3	1.4
			$X_L$	-4.9	-3.4	10.6	7.3	4.9	3.4	-.055	-10.6	-1.5
			$X_U$	6.1	4.2	16.2	11.2	7.3	5.0	.109	6.0	4.3
			$f s_H^2 / s_G^2$	.23	.23	.54	.53	1.00	1.00	1.56	.33	.16

<sup>a</sup> Specimen exposed in gaseous helium throughout test.

<sup>b</sup> Unirradiated specimen cooled to 17 K and held for 1 hr prior to warming and testing. Irradiated specimen cooled to and held at 17 K throughout irradiation exposure. Fast fluence is for neutron energies greater than 0.5 MeV (80 fJ).

<sup>c</sup> Specimen warmed to and held for 1 hr at test temperature, then fractured at test temperature.

<sup>d</sup> Arithmetic mean,  $\bar{X}$ ; estimated standard deviation,  $s$ ; lower and upper limits of 95-percent confidence interval of the difference,  $X_L$ ,  $X_U$ .

<sup>e</sup> Total elongation in 0.5-in. (1.27-cm) gage length.

<sup>f</sup> Values for tensile modulus of elasticity, yield strength, and ultimate strength differ because of significant figures maintained in comparative calculations between the two systems of units.

TABLE V. - EFFECT OF ANNEALING FOLLOWING REACTOR IRRADIATION AT 17 K ON  
TENSILE PROPERTIES OF COMMERCIALY PURE TITANIUM<sup>a</sup>

Specimen	Fast fluence, neutrons/cm <sup>2</sup> (b)	Annealing temperature, K (c)	Statistical analysis (d)	Tensile modulus of elasticity		Yield strength (0.2-percent offset)		Ultimate strength		Yield- to ultimate-strength ratio	Total- elongation, percent (e)	Reduction of area, percent
				lb/in. <sup>2</sup>	N/m <sup>2</sup>	lb/in. <sup>2</sup>	N/m <sup>2</sup>	lb/in. <sup>2</sup>	N/m <sup>2</sup>			
1Aa34	0	78	-----	19.0×10 <sup>6</sup>	13.1×10 <sup>10</sup>	131.0×10 <sup>3</sup>	90.3×10 <sup>7</sup>	184.0×10 <sup>3</sup>	126.8×10 <sup>7</sup>	0.711	30.0	46.0
1Aa16	0	78	-----	18.0	12.4	135.0	93.0	188.0	129.5	.718	35.0	44.0
1Aa19	0	78	-----	19.0	13.1	136.0	93.7	184.0	126.8	.738	28.0	48.0
			$\bar{X}_I$	18.7×10 <sup>6</sup>	12.9×10 <sup>10</sup>	134.0×10 <sup>3</sup>	92.3×10 <sup>7</sup>	185.3×10 <sup>3</sup>	127.7×10 <sup>7</sup>	0.722	31.0	46.0
			$s_I$	.6	.4	2.6	1.8	2.3	1.6	.014	3.6	2.0
1Aa47	6×10 <sup>17</sup>	78	-----	19.0×10 <sup>6</sup>	13.1×10 <sup>10</sup>	151.0×10 <sup>3</sup>	104.0×10 <sup>7</sup>	196.0×10 <sup>3</sup>	135.0×10 <sup>7</sup>	0.770	30.0	47.0
1Aa4	6	78	-----	-----	-----	152.0	104.7	190.0	130.9	.799	24.0	47.0
1Aa14	6	78	-----	20.0	13.8	152.0	104.7	195.0	134.4	.779	26.0	44.0
			$\bar{X}_J$	19.5×10 <sup>6</sup>	13.4×10 <sup>10</sup>	151.7×10 <sup>3</sup>	104.5×10 <sup>7</sup>	193.7×10 <sup>3</sup>	133.4×10 <sup>7</sup>	0.783	26.7	46.0
			$s_J$	.7	.5	.6	.4	3.2	2.2	.015	3.1	1.7
			$\bar{X}_J - \bar{X}_I$	.8	.5	17.7	12.2	8.4	5.7	.061	-4.3	0
			$X_L$	-.9	-.6	11.1	7.6	2.6	1.8	.032	-11.0	-3.7
			$X_U$	2.5	1.7	24.3	16.8	14.2	9.8	.090	2.4	3.7
			$f_{s_J^2/s_I^2}$	1.36	1.56	.05	.05	1.94	1.89	1.15	.74	.72
1Aa25	0	178	-----	18.0×10 <sup>6</sup>	12.4×10 <sup>10</sup>	131.0×10 <sup>3</sup>	90.3×10 <sup>7</sup>	176.0×10 <sup>3</sup>	121.3×10 <sup>7</sup>	0.744	32.0	52.0
1Aa53	0	178	-----	19.0	13.1	134.0	92.3	184.0	126.8	.728	31.0	54.0
1Aa24	0	178	-----	18.0	12.4	134.0	92.3	186.0	128.2	.720	36.0	50.0
			$\bar{X}_K$	18.3×10 <sup>6</sup>	12.6×10 <sup>10</sup>	133.0×10 <sup>3</sup>	91.6×10 <sup>7</sup>	182.0×10 <sup>3</sup>	125.4×10 <sup>7</sup>	0.731	33.0	52.0
			$s_K$	.6	.4	1.7	1.2	5.3	3.7	.012	2.6	2.0
1Aa28	6×10 <sup>17</sup>	178	-----	19.0×10 <sup>6</sup>	13.1×10 <sup>10</sup>	145.0×10 <sup>3</sup>	99.9×10 <sup>7</sup>	192.0×10 <sup>3</sup>	132.3×10 <sup>7</sup>	0.755	29.0	48.0
1Aa50	6	178	-----	20.0	13.8	146.0	100.6	194.0	133.7	.752	30.0	47.0
1Aa41	6	178	-----	22.0	15.2	149.0	102.7	195.0	134.4	.764	27.0	46.0
			$\bar{X}_L$	20.3×10 <sup>6</sup>	14.0×10 <sup>10</sup>	146.7×10 <sup>3</sup>	101.1×10 <sup>7</sup>	193.7×10 <sup>3</sup>	133.5×10 <sup>7</sup>	0.757	28.7	47.0
			$s_L$	1.5	1.0	2.1	1.5	1.5	1.1	.006	1.5	1.0
			$\bar{X}_L - \bar{X}_K$	2.0	1.4	13.7	9.5	11.7	8.1	.026	-4.3	-5.0
			$X_L$	-.9	-.6	9.9	6.9	1.6	1.1	.004	-9.1	-8.6
			$X_U$	4.9	3.4	17.5	12.1	21.8	15.1	.048	.5	-1.4
			$f_{s_L^2/s_K^2}$	6.25	6.25	1.52	1.56	.08	.09	.25	.33	.25

<sup>a</sup>Specimen exposed in gaseous helium throughout test.

<sup>b</sup>Unirradiated specimen cooled to 17 K and held for 1 hr prior to annealing. Irradiated specimen cooled to and held at 17 K throughout irradiation exposure. Fast fluence is for E > 0.5 MeV (80 fJ).

<sup>c</sup>Specimen warmed from 17 K to annealing temperature, held 1 hr at annealing temperature, cooled to 17 K, held 1 hr at 17 K.

<sup>d</sup>Arithmetic mean,  $\bar{X}$ ; estimated standard deviation,  $s$ ; lower and upper limits of 95-percent confidence interval of the difference,  $X_L$ ,  $X_U$ .

<sup>e</sup>Total elongation in 0.5-in. (1.27-cm) gage length.

<sup>f</sup>Values for tensile modulus of elasticity, yield strength, and ultimate strength differ because of significant figures maintained in comparative calculations between the two systems of units.

TABLE VI. - EFFECT OF REACTOR IRRADIATION AT 17 K on 17 K TENSILE PROPERTIES  
ON NORMAL IMPURITY TITANIUM - 5 ALUMINUM - 2.5 TIN ALLOY

Specimen	Fast fluence, neutrons/cm <sup>2</sup> (a)	Statistical analysis (b)	Tensile modulus of elasticity		Yield strength (0.2-percent offset)		Ultimate strength		Yield- to ultimate- strength ratio	Total elon- gation, percent (c)	Reduction of area, percent
			lb/in. <sup>2</sup>	N/m <sup>2</sup>	lb/in. <sup>2</sup>	N/m <sup>2</sup>	lb/in. <sup>2</sup>	N/m <sup>2</sup>			
3Aa55	0	-----	18.0×10 <sup>6</sup>	12.4×10 <sup>10</sup>	200.0×10 <sup>3</sup>	137.8×10 <sup>7</sup>	231.0×10 <sup>3</sup>	159.2×10 <sup>7</sup>	0.865	18.0	21.0
3Aa54	0	-----	17.5	12.1	201.0	138.5	213.0	146.8	.943	12.0	30.0
3Aa30	0	-----	18.2	12.5	-----	-----	225.0	155.0	-----	12.0	35.0
3Aa21	0	-----	18.4	12.7	205.0	141.2	229.0	157.8	.895	13.0	34.0
3Aa29	0	-----	18.2	12.5	215.0	148.1	226.0	155.7	.951	-----	-----
		$\bar{X}_A$	18.1×10 <sup>6</sup>	12.5×10 <sup>10</sup>	205.3×10 <sup>3</sup>	141.1×10 <sup>7</sup>	224.8×10 <sup>3</sup>	154.9×10 <sup>7</sup>	0.914	13.8	30.0
		$s_A$	.3	.2	6.9	4.7	7.0	4.8	.041	2.9	6.4
		$\bar{X}_A - \bar{X}_A$	0	0	0	0	0	0	0	0	0
		$X_L$	-.4	-.3	-11.0	-7.5	-8.7	-6.0	-.065	-4.6	-10.2
		$X_U$	.4	.3	11.0	7.5	8.7	6.0	.065	4.6	10.2
3Aa58	1×10 <sup>17</sup>	-----	14.8×10 <sup>6</sup>	10.2×10 <sup>10</sup>	211.0×10 <sup>3</sup>	145.4×10 <sup>7</sup>	257.0×10 <sup>3</sup>	177.0×10 <sup>7</sup>	0.821	---	----
3Aa52	1	-----	18.1	12.5	212.0	146.1	222.0	153.0	.955	9.0	----
3Aa57	1	-----	20.5	14.1	231.0	159.2	238.0	164.0	.970	14.0	36.0
		$\bar{X}_B$	17.8×10 <sup>6</sup>	12.3×10 <sup>10</sup>	218.0×10 <sup>3</sup>	150.2×10 <sup>7</sup>	239.0×10 <sup>3</sup>	164.7×10 <sup>7</sup>	0.915	11.5	36.0
		$s_B$	2.9	2.0	11.3	7.8	17.5	12.0	.082	3.5	----
		$\bar{X}_B - \bar{X}_A$	-.3	-.2	12.7	8.8	14.2	9.8	.001	-2.3	6.0
		$X_L$	-7.5	-5.2	-7.8	-5.4	-19.5	-13.4	-.164	-11.4	----
		$X_U$	6.9	4.8	33.2	22.9	47.9	33.0	.166	6.8	----
		$d^2 s_B^2 / s_A^2$	93.44	100.00	2.68	2.76	6.25	6.24	4.00	1.46	----
3Aa73	10×10 <sup>17</sup>	-----	20.0×10 <sup>6</sup>	13.8×10 <sup>10</sup>	205.3×10 <sup>3</sup>	141.5×10 <sup>7</sup>	211.8×10 <sup>3</sup>	145.9×10 <sup>7</sup>	0.969	8.0	34.0
3Aa168	10	-----	20.0	13.8	220.6	152.0	226.8	156.3	.971	8.0	34.0
3Aa167	10	-----	16.0	11.0	248.2	171.0	250.8	172.8	.990	7.0	27.0
3Aa169	10	-----	22.0	15.2	262.8	181.1	270.8	186.6	.970	8.0	33.0
3Aa63	10	-----	25.0	17.2	279.9	192.9	289.2	199.3	.967	6.0	21.0
		$\bar{X}_C$	20.6×10 <sup>6</sup>	14.2×10 <sup>10</sup>	243.4×10 <sup>3</sup>	167.7×10 <sup>7</sup>	249.9×10 <sup>3</sup>	172.2×10 <sup>7</sup>	0.973	7.4	29.8
		$s_C$	3.3	2.3	30.4	21.0	31.5	21.7	.009	.9	5.3
		$\bar{X}_C - \bar{X}_A$	2.5	1.7	38.1	26.3	25.1	17.3	.059	-6.4	-.2
		$X_L$	-1.6	-1.1	2.0	1.4	-12.0	-8.3	-.008	-10.6	-9.7
		$X_U$	6.6	4.5	74.2	51.2	62.2	42.9	.126	-2.2	9.3
		$d^2 s_C^2 / s_A^2$	121.00	132.25	19.39	19.96	20.25	20.42	.05	.10	.68

<sup>a</sup>Specimen exposed in gaseous helium at 17 K throughout test. Fast fluence is for E > 0.5 MeV (80 fJ).

<sup>b</sup>Arithmetic mean,  $\bar{X}$ ; estimated standard deviation, s; lower and upper limits of 95-percent confidence interval of the difference,  $X_L$ ,  $X_U$ .

<sup>c</sup>Total elongation in 0.5-in. (1.27-cm) gage length.

<sup>d</sup>Values for tensile modulus of elasticity, yield strength, and ultimate strength differ because of significant figures maintained in comparative calculations between the two systems of units.



TABLE VII. - EFFECT OF REACTOR IRRADIATION AT 17 K ON 17 K TENSILE PROPERTIES OF EXTRA LOW

IMPURITY TITANIUM - 5 ALUMINUM - 2.5 TIN ALLOY

Specimen	Fast fluence, neutrons/cm <sup>2</sup> (a)	Statistical analysis (b)	Tensile modulus of elasticity		Yield strength (0.2-percent offset)		Ultimate strength		Yield- to ultimate-strength ratio	Total elongation, percent (c)	Reduction of area, percent
			lb/in. <sup>2</sup>	N/m <sup>2</sup>	lb/in. <sup>2</sup>	N/m <sup>2</sup>	lb/in. <sup>2</sup>	N/m <sup>2</sup>			
8Aa18	0	-----	-----	-----	203.0×10 <sup>3</sup>	139.9×10 <sup>7</sup>	231.0×10 <sup>3</sup>	159.2×10 <sup>7</sup>	0.879	---	----
8Aa32	0	-----	22.5×10 <sup>6</sup>	15.5×10 <sup>10</sup>	213.0	146.8	223.0	153.6	.955	8.0	33.0
8Aa35	0	-----	-----	-----	213.0	146.8	225.0	155.0	.947	11.0	32.0
8Aa34	0	-----	20.8	14.3	217.0	149.5	227.0	156.4	.956	10.0	32.0
8Aa27	0	-----	22.4	15.4	225.0	155.0	236.0	162.6	.954	----	----
		$\bar{X}_D$	21.9×10 <sup>6</sup>	15.1×10 <sup>10</sup>	214.2×10 <sup>3</sup>	147.6×10 <sup>7</sup>	228.4×10 <sup>3</sup>	157.4×10 <sup>7</sup>	0.938	9.7	32.3
		$s_D$	.9	.7	8.0	5.5	5.2	3.6	.033	1.5	.6
		$\bar{X}_D - \bar{X}_D$	0	0	0	0	0	0	0	0	0
		$X_L$	-2.2	-1.7	-9.9	-6.8	-6.4	-4.4	-.041	-3.7	-1.5
		$X_U$	2.2	1.7	9.9	6.8	6.4	4.4	.041	3.7	1.5
8Aa25	1×10 <sup>17</sup>	-----	18.7×10 <sup>6</sup>	12.9×10 <sup>10</sup>	211.0×10 <sup>3</sup>	145.4×10 <sup>7</sup>	222.0×10 <sup>3</sup>	153.0×10 <sup>7</sup>	0.950	11.0	31.0
8Aa24	1	-----	18.5	12.7	213.0	146.8	225.0	155.0	.947	----	----
8Aa12	1	-----	18.7	12.9	215.0	148.1	223.0	153.6	.964	----	----
		$\bar{X}_E$	18.6×10 <sup>6</sup>	12.8×10 <sup>10</sup>	213.0×10 <sup>3</sup>	146.8×10 <sup>7</sup>	223.3×10 <sup>3</sup>	153.9×10 <sup>7</sup>	0.953	11.0	31.0
		$s_E$	.1	.1	2.0	1.4	1.5	1.0	.009	----	----
		$\bar{X}_E - \bar{X}_D$	-3.3	-2.3	-1.2	-.8	-5.1	-3.5	.015	1.3	-1.3
		$X_L$	-5.5	-3.8	-10.7	-7.4	-11.2	-7.7	-.026	---	----
		$X_U$	-1.1	-.8	8.3	5.7	1.0	.7	.056	---	----
		$d s_E^2 / s_D^2$	.01	.02	.06	.06	.08	.09	.07	---	----
8Aa60	10×10 <sup>17</sup>	-----	22.0×10 <sup>6</sup>	15.2×10 <sup>10</sup>	250.0×10 <sup>3</sup>	172.3×10 <sup>7</sup>	252.6×10 <sup>3</sup>	174.0×10 <sup>7</sup>	0.990	6.0	27.0
8Aa49	10	-----	22.0	15.2	262.1	180.6	268.0	184.7	.978	6.0	22.0
8Aa55	10	-----	23.0	15.8	263.1	181.3	270.9	186.7	.971	6.0	25.0
		$\bar{X}_F$	22.3×10 <sup>6</sup>	15.4×10 <sup>10</sup>	258.4×10 <sup>3</sup>	178.1×10 <sup>7</sup>	263.8×10 <sup>3</sup>	181.8×10 <sup>7</sup>	0.980	6.0	24.7
		$s_F$	.6	.4	7.3	5.0	9.8	6.8	.010	0	2.5
		$\bar{X}_F - \bar{X}_D$	.4	.3	44.2	30.5	35.4	24.4	.042	-3.7	-7.6
		$X_L$	-1.2	-.8	31.2	21.5	15.7	10.8	.003	-7.4	-14.0
		$X_U$	2.0	1.4	57.2	39.5	55.1	38.0	.081	0	-1.2
		$d s_F^2 / s_D^2$	.44	.33	.83	.83	3.55	3.57	.09	0	17.36

<sup>a</sup>Specimen exposed in gaseous helium at 17 K throughout test. Fast fluence is for E > 0.5 MeV (80 fJ).

<sup>b</sup>Arithmetic mean,  $\bar{X}$ ; estimated standard deviation,  $s$ ; lower and upper limits of 95 percent confidence interval of the difference,  $X_L$ ,  $X_U$ .

<sup>c</sup>Total elongation in 0.5-in. (1.27-cm) gage length.

<sup>d</sup>Values for tensile modulus of elasticity, yield strength, and ultimate strength differ because of significant figures maintained in comparative calculations between the two systems of units.

TABLE VIII. - EFFECT OF REACTOR IRRADIATION AT 17 K ON 17 K TENSILE PROPERTIES OF ANNEALED

TITANIUM - 6 ALUMINUM - 4 VANADIUM ALLOY

Specimen	Fast fluence, neutrons/cm <sup>2</sup> (a)	Statistical analysis (b)	Tensile modulus of elasticity		Yield strength (0.2-percent offset)		Ultimate strength		Yield- to ultimate-strength ratio	Total elongation, percent (c)	Reduction of area, percent
			lb/in. <sup>2</sup>	N/m <sup>2</sup>	lb/in. <sup>2</sup>	N/m <sup>2</sup>	lb/in. <sup>2</sup>	N/m <sup>2</sup>			
2Ac1	0	-----	17.6×10 <sup>6</sup>	12.1×10 <sup>10</sup>	228.0×10 <sup>3</sup>	157.1×10 <sup>7</sup>	249.0×10 <sup>3</sup>	171.6×10 <sup>7</sup>	0.915	10.0	30.0
2Ac9	0	-----	16.3	11.2	230.0	158.5	264.0	181.9	.871	7.0	30.0
2Ac71	0	-----	17.7	12.2	250.0	172.3	265.0	182.6	.943	↓	36.0
2Ac10	0	-----	17.9	12.3	253.0	174.3	261.0	179.8	.969		27.0
2Ac12	0	-----	16.8	11.6	255.0	175.7	263.0	181.2	.969		29.0
		$\bar{X}_A$	17.3×10 <sup>6</sup>	11.9×10 <sup>10</sup>	243.2×10 <sup>3</sup>	167.6×10 <sup>7</sup>	260.4×10 <sup>3</sup>	179.4×10 <sup>7</sup>	.933	7.6	30.4
		$s_A$	.7	.5	13.1	9.0	6.5	4.5	.041	1.3	3.4
		$\bar{X}_A - \bar{X}_A$	0	0	0	0	0	0	0	0	0
		$X_L$	-.9	-.6	-16.2	-11.2	-8.1	-5.6	-.051	-1.5	-4.2
		$X_U$	.9	.6	16.2	11.2	8.1	5.6	.051	1.5	4.2
2Ac59	1×10 <sup>17</sup>	-----	-----	-----	-----	-----	265.0×10 <sup>3</sup>	182.6×10 <sup>7</sup>	-----	6.0	37.0
2Ac61	1	-----	24.8×10 <sup>6</sup>	17.1×10 <sup>10</sup>	254.0×10 <sup>3</sup>	175.0×10 <sup>7</sup>	266.0	183.3	0.955	5.0	37.0
2Ac72	1	-----	-----	-----	-----	-----	290.1	199.8	-----	6.0	38.0
		$\bar{X}_B$	24.8×10 <sup>6</sup>	17.1×10 <sup>10</sup>	254.0×10 <sup>3</sup>	175.0×10 <sup>7</sup>	273.7×10 <sup>3</sup>	188.6×10 <sup>7</sup>	0.955	5.7	37.3
		$s_B$	-----	-----	-----	-----	14.2	9.7	-----	.6	.6
		$\bar{X}_B - \bar{X}_A$	7.5	5.2	10.8	7.4	13.3	9.2	.022	-1.9	6.9
		$X_L$	-----	-----	-----	-----	-14.4	-9.9	-----	-3.5	2.9
		$X_U$	-----	-----	-----	-----	41.0	28.2	-----	-.3	10.9
		$d \frac{s_B^2}{s_A^2}$	-----	-----	-----	-----	4.76	4.64	-----	.21	.03
2Ac54	10×10 <sup>17</sup>	-----	20.0×10 <sup>6</sup>	13.8×10 <sup>10</sup>	289.4×10 <sup>3</sup>	199.4×10 <sup>7</sup>	302.7×10 <sup>3</sup>	208.6×10 <sup>7</sup>	0.956	4.0	34.0
2Ac56	10	-----	-----	-----	294.7	203.0	325.0	223.9	.907	6.0	34.0
2Ac55	10	-----	25.0	17.2	314.5	216.7	332.9	229.4	.945	4.0	34.0
		$\bar{X}_C$	22.5×10 <sup>6</sup>	15.5×10 <sup>10</sup>	299.5×10 <sup>3</sup>	206.4×10 <sup>7</sup>	320.2×10 <sup>3</sup>	220.6×10 <sup>7</sup>	0.936	4.7	34.0
		$s_C$	3.5	2.4	13.2	9.1	15.7	10.8	.026	1.2	0
		$\bar{X}_C - \bar{X}_A$	5.2	3.6	56.3	38.8	59.8	41.2	.003	-2.9	3.6
		$X_L$	<sup>e</sup> -26.6	<sup>e</sup> -17.8	32.8	22.6	29.5	20.3	-.052	-5.1	-.6
		$X_U$	37.0	25.0	79.8	55.0	90.1	62.1	.058	-.7	7.8
		$d \frac{s_C^2}{s_A^2}$	25.00	23.03	1.02	1.02	5.83	5.75	.40	.85	0

<sup>a</sup>Specimen exposed in gaseous helium at 17 K throughout test. Fast fluence is for E > 0.5 MeV (80 kJ).

<sup>b</sup>Arithmetic mean,  $\bar{X}$ ; estimated standard deviation,  $s$ ; lower and upper limits of 95-percent confidence interval of the difference,  $X_L$ ,  $X_U$ .

<sup>c</sup>Total elongation in 0.5-in. (1.27-cm) gage length.

<sup>d</sup>Values for tensile modulus of elasticity, yield strength, and ultimate strength differ because of significant figures maintained in comparative calculations between the two system of units.

<sup>e</sup>Value exceeds lower limit of possible change.

TABLE IX. - EFFECT OF REACTOR IRRADIATION AT 17 K ON 17 K TENSILE PROPERTIES OF AGED

TITANIUM - 6 ALUMINUM - 4 VANADIUM ALLOY

Specimen	Fast fluence, neutrons/cm <sup>2</sup> (a)	Statistical analysis (b)	Tensile modulus of elasticity		Yield strength (0.2-percent offset)		Ultimate strength		Yield- to ultimate-strength ratio	Total elongation, percent (c)	Reduction of area, percent
			lb/in. <sup>2</sup>	N/m <sup>2</sup>	lb/in. <sup>2</sup>	N/m <sup>2</sup>	lb/in. <sup>2</sup>	N/m <sup>2</sup>			
2Aa30	0	-----	20.4×10 <sup>6</sup>	14.1×10 <sup>10</sup>	273.0×10 <sup>3</sup>	188.1×10 <sup>7</sup>	286.0×10 <sup>3</sup>	197.1×10 <sup>7</sup>	0.954	6.0	22.0
2Aa11	0	-----	19.7	13.6	274.0	188.8	277.0	190.9	.989	7.0	28.0
2Aa29	0	-----	17.1	11.8	274.0	188.8	281.0	193.6	.975	7.0	24.0
2Aa10	0	-----	17.4	12.0	275.0	189.5	284.0	195.7	.969	7.0	31.0
2Aa13	0	-----	18.1	12.5	279.0	192.2	283.0	195.0	.986	5.0	22.0
		$\bar{X}_D$	18.5×10 <sup>6</sup>	12.8×10 <sup>10</sup>	275.0×10 <sup>3</sup>	189.5×10 <sup>7</sup>	282.2×10 <sup>3</sup>	194.5×10 <sup>7</sup>	0.975	6.4	25.4
		$s_D$	1.5	1.0	2.4	1.6	3.4	2.4	.014	.9	4.0
		$\bar{X}_D - \bar{X}_D$	0	0	0	0	0	0	0	0	0
		$X_L$	-1.9	-1.3	-3.0	-2.0	-4.2	-2.9	-.017	-1.1	-5.0
		$X_U$	1.9	1.3	3.0	2.0	4.2	2.9	.017	1.1	5.0
2Aa43	1×10 <sup>17</sup>	-----	-----	-----	281.0×10 <sup>3</sup>	193.6×10 <sup>7</sup>	296.0×10 <sup>3</sup>	203.9×10 <sup>7</sup>	0.949	5.0	24.0
2Aa44	1	-----	14.6×10 <sup>6</sup>	10.1×10 <sup>10</sup>	294.0	202.6	303.0	208.8	.970	---	---
2Aa77	1	-----	-----	-----	305.0	210.1	308.0	212.2	.990	5.0	21.0
		$\bar{X}_E$	14.6×10 <sup>6</sup>	10.1×10 <sup>10</sup>	293.3×10 <sup>3</sup>	202.1×10 <sup>7</sup>	302.3×10 <sup>3</sup>	208.3×10 <sup>7</sup>	0.970	5.0	22.5
		$s_E$	-----	-----	12.0	8.3	6.0	4.1	.021	0	2.1
		$\bar{X}_E - \bar{X}_D$	-3.9	-2.7	18.3	12.6	20.1	13.8	-.005	-1.4	-2.9
		$X_L$	-----	-----	-11.9	-8.2	9.6	6.6	-.044	-2.5	-8.4
		$X_U$	-----	-----	48.5	33.4	30.6	21.1	-.034	-.3	2.6
		$d_s^2 \frac{2}{E} / \frac{2}{D}$	-----	-----	25.00	26.85	3.11	2.92	2.25	0	.28
2Aa78	10×10 <sup>17</sup>	-----	20.0×10 <sup>6</sup>	13.8×10 <sup>10</sup>	289.5×10 <sup>3</sup>	199.5×10 <sup>7</sup>	296.1×10 <sup>3</sup>	204.0×10 <sup>7</sup>	0.978	5.0	21.0
2Aa87	10	-----	15.0	10.3	-----	-----	324.8	223.8	-----	4.0	13.0
2Aa89	10	-----	19.0	13.1	319.0	219.8	325.2	224.1	.980	5.0	16.0
2Aa82	10	-----	20.0	13.8	322.1	221.9	328.3	226.2	.981	5.0	14.0
2Aa81	10	-----	22.0	15.2	365.5	251.8	373.2	257.1	.979	3.0	13.0
		$\bar{X}_F$	19.2×10 <sup>6</sup>	13.2×10 <sup>10</sup>	324.0×10 <sup>3</sup>	233.3×10 <sup>7</sup>	329.5×10 <sup>3</sup>	227.0×10 <sup>7</sup>	0.979	4.4	15.4
		$s_F$	2.6	1.8	31.3	21.5	27.7	19.1	.002	.9	3.4
		$\bar{X}_F - \bar{X}_D$	.7	.4	49.0	33.8	47.3	32.5	.004	-2.0	-10.0
		$X_L$	-2.4	-1.7	-.9	-.6	12.7	8.7	-.013	-3.3	-15.3
		$X_U$	3.8	2.6	98.9	68.2	81.9	56.3	.021	-.7	-4.7
		$d_s^2 \frac{2}{F} / \frac{2}{D}$	3.00	3.24	170.09	180.57	66.37	63.34	.02	1.00	.72

<sup>a</sup>Specimen exposed in gaseous helium at 17 K throughout test. Fast fluence is  $E > 0.5$  MeV (80 fJ).

<sup>b</sup>Arithmetic mean,  $\bar{X}$ ; estimated standard deviation,  $s$ ; lower and upper limits of 95-percent confidence interval of the difference,  $X_L, X_U$ .

<sup>c</sup>Total elongation in 0.5-in. (1.27-cm) gage length.

<sup>d</sup>Values for tensile modulus of elasticity, yield strength, and ultimate strength differ because of significant figures maintained in comparative calculations between the two system of units.

TABLE X. - EFFECT OF REACTOR IRRADIATION AT 17 K ON 17 K TENSILE PROPERTIES OF  
TITANIUM - 8 ALUMINUM - 1 MOLYBDENUM - 4 VANADIUM ALLOY

Specimen	Fast fluence, neutrons/cm <sup>2</sup> (a)	Statistical analysis (b)	Tensile modulus of elasticity		Yield strength (0.2-percent offset)		Ultimate strength		Yield- to ultimate- strength ratio	Total elon- gation, percent (c)	Reduction of area, percent
			lb/in. <sup>2</sup>	N/m <sup>2</sup>	lb/in. <sup>2</sup>	N/m <sup>2</sup>	lb/in. <sup>2</sup>	N/m <sup>2</sup>			
4Aa3	0 ↓	-----	19.2×10 <sup>6</sup>	13.2×10 <sup>10</sup>	217.0×10 <sup>3</sup>	149.5×10 <sup>7</sup>	236.0×10 <sup>3</sup>	162.6×10 <sup>7</sup>	0.920	12.1	----
4Aa1		-----	18.3	12.6	220.0	151.6	242.0	166.7	.909	5.8	----
4Aa4		-----	16.4	11.3	224.0	154.3	236.0	162.6	.950	7.8	----
4Aa5		-----	18.5	12.7	224.0	154.3	238.0	164.0	.940	7.8	----
4Aa2		-----	18.9	13.0	236.0	162.6	243.0	167.4	.970	15.2	----
			$\bar{X}_A$	18.3×10 <sup>6</sup>	12.6×10 <sup>10</sup>	224.2×10 <sup>3</sup>	154.5×10 <sup>7</sup>	239.0×10 <sup>3</sup>	164.7×10 <sup>7</sup>	0.938	9.5
		$s_A$	1.1	.7	7.2	5.0	3.3	2.3	.024	3.8	----
		$\bar{X}_A - \bar{X}_A$	0	0	0	0	0	0	0	0	----
		$X_L$	-1.4	-1.0	-8.9	-6.1	-4.2	-2.9	-.030	-4.7	----
		$X_U$	1.4	1.0	8.9	6.1	4.2	2.9	.030	4.7	----
4Aa34	1×10 <sup>17</sup>	-----	19.6×10 <sup>6</sup>	13.5×10 <sup>10</sup>	238.0×10 <sup>3</sup>	164.0×10 <sup>7</sup>	264.0×10 <sup>3</sup>	181.9×10 <sup>7</sup>	0.901	6.0	31.0
4Aa43	1	-----	25.4	17.5	243.0	167.4	262.0	180.5	.927	5.0	26.0
4Aa38	1	-----	-----	-----	247.0	170.2	259.0	178.5	.954	6.0	30.0
		$\bar{X}_B$	22.5×10 <sup>6</sup>	15.5×10 <sup>10</sup>	242.7×10 <sup>3</sup>	167.2×10 <sup>7</sup>	261.7×10 <sup>3</sup>	180.3×10 <sup>7</sup>	0.927	5.7	29.0
		$s_B$	4.1	2.8	4.5	3.1	2.5	1.7	.027	.6	2.6
		$\bar{X}_B - \bar{X}_A$	4.2	2.9	18.5	12.7	22.7	15.6	-.011	-3.8	----
		$X_L$	<sup>e</sup> -33.2	<sup>e</sup> -22.9	9.0	6.2	17.9	12.3	-.057	-8.6	----
		$X_U$	41.6	28.7	28.0	19.3	27.5	18.9	.035	1.0	----
		$d_{s_B}^2/s_A^2$	13.90	16.00	.39	.38	.57	.55	1.26	.02	----

<sup>a</sup>Specimen exposed in gaseous helium at 17 K throughout test. Fast fluence is for E > 0.5 MeV (80 fJ).

<sup>b</sup>Arithmetic mean,  $\bar{X}$ ; estimated standard deviation, s; lower and upper limits of 95-percent confidence interval of the difference,  $X_L$ ,  $X_U$ .

<sup>c</sup>Total elongation on 0.5-in. (1.27-cm) gage length.

<sup>d</sup>Values for tensile modulus of elasticity, yield strength, and ultimate strength differ because of significant figures maintained in comparative calculations between the two system of units.

<sup>e</sup>Value exceeds lower limit of possible change.

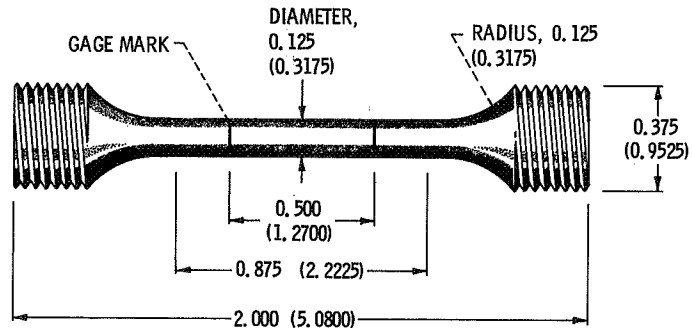

CD-10485-17

Figure 1. - Miniature round tensile test specimen. All dimensions are in inches (cm).

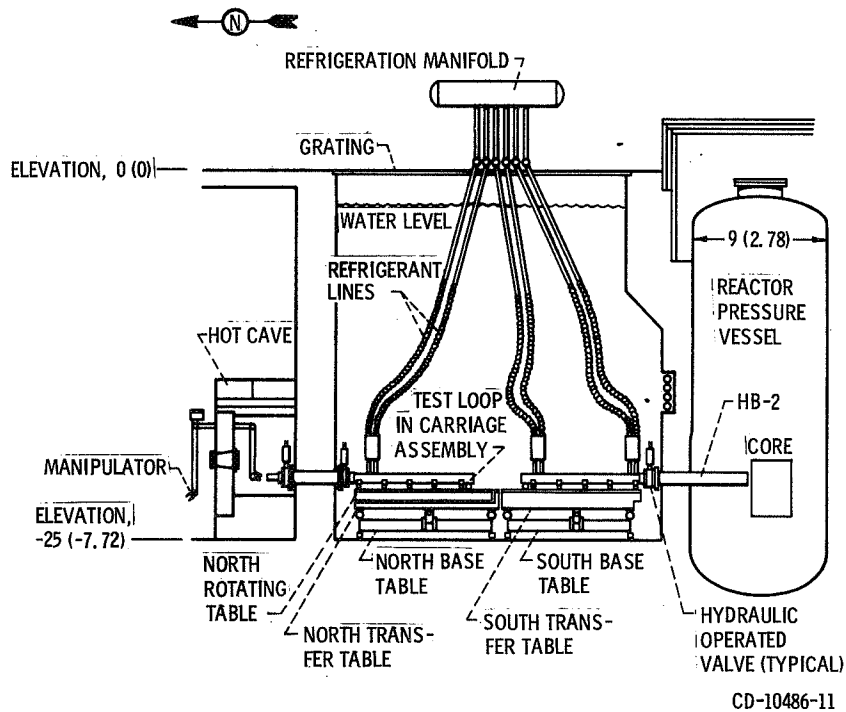

CD-10486-11

Figure 2. - Cryogenic irradiation test equipment. All dimensions are in feet (m).

NASA-Lewis

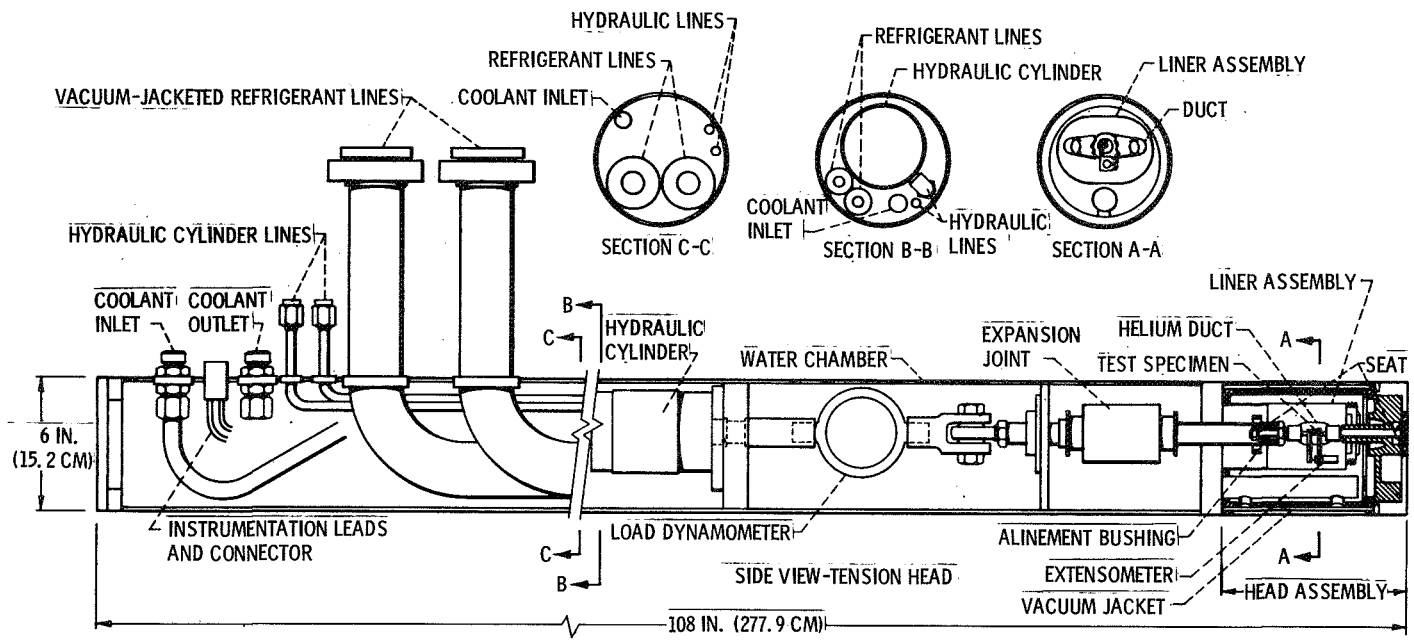

Figure 3. - Cryogenic irradiation test loop.

CD-10487-22

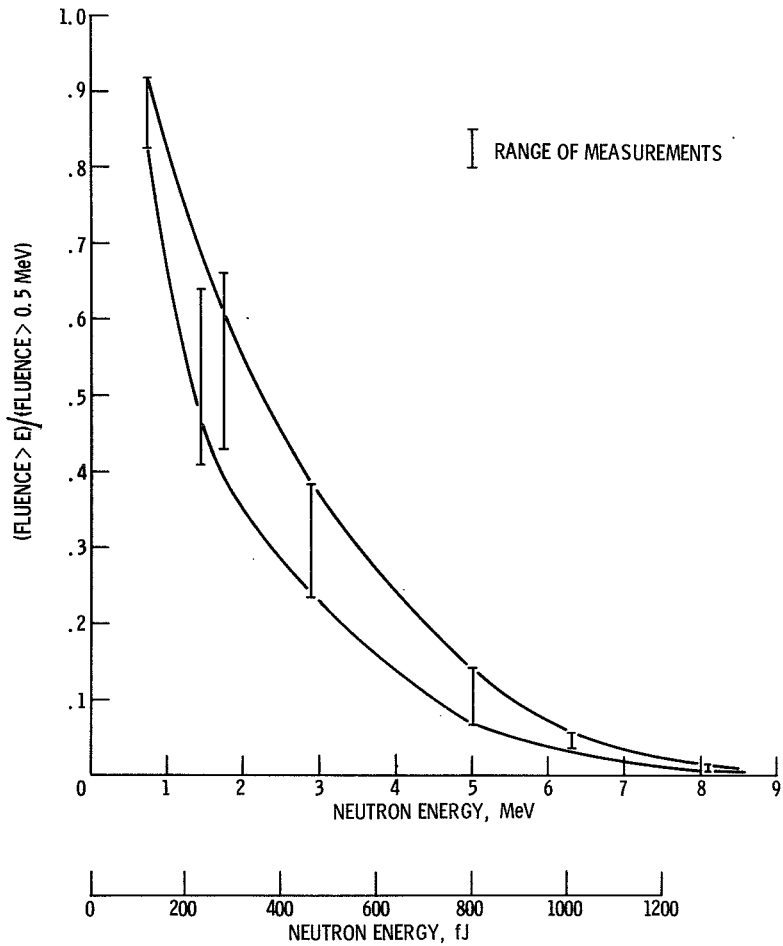

Figure 4. - Ratio of fluence greater than E to fluence greater than 0.5 MeV (80 fJ).

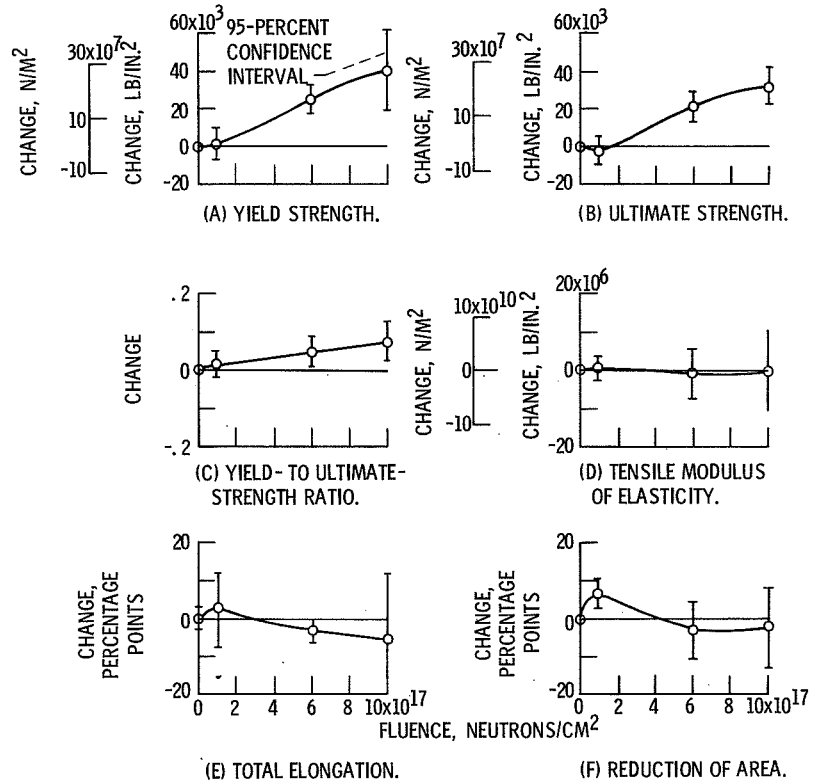

Figure 5. - Effect of reactor irradiation at 17 K on 17 K tensile properties of commercially pure titanium. Neutron energy > 0.5 MeV (80 fJ).

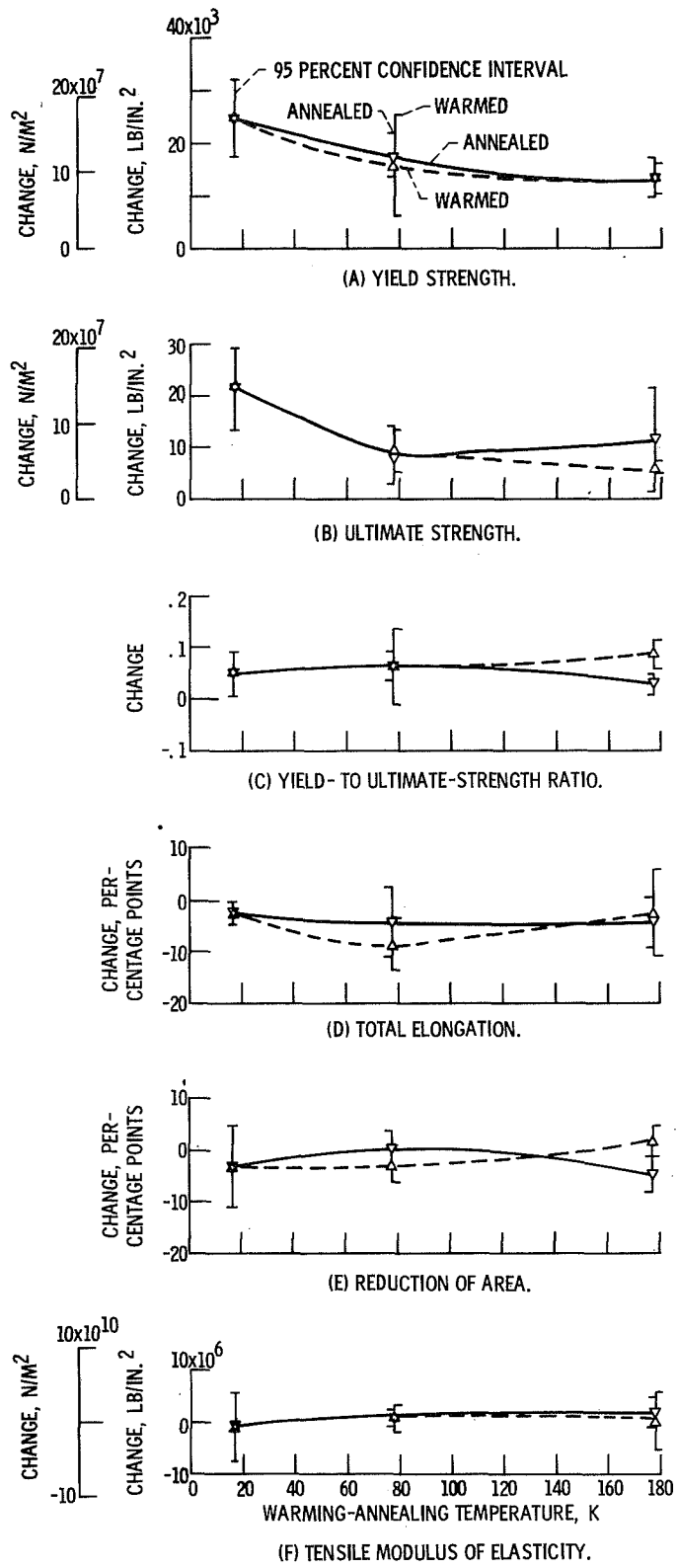

Figure 6. - Effect of postirradiation warming and annealing on tensile properties of commercially pure titanium irradiated at 17 K to  $6 \times 10^{17}$  neutrons per square centimeter. Energy  $> 0.5$  MeV (80 fJ).



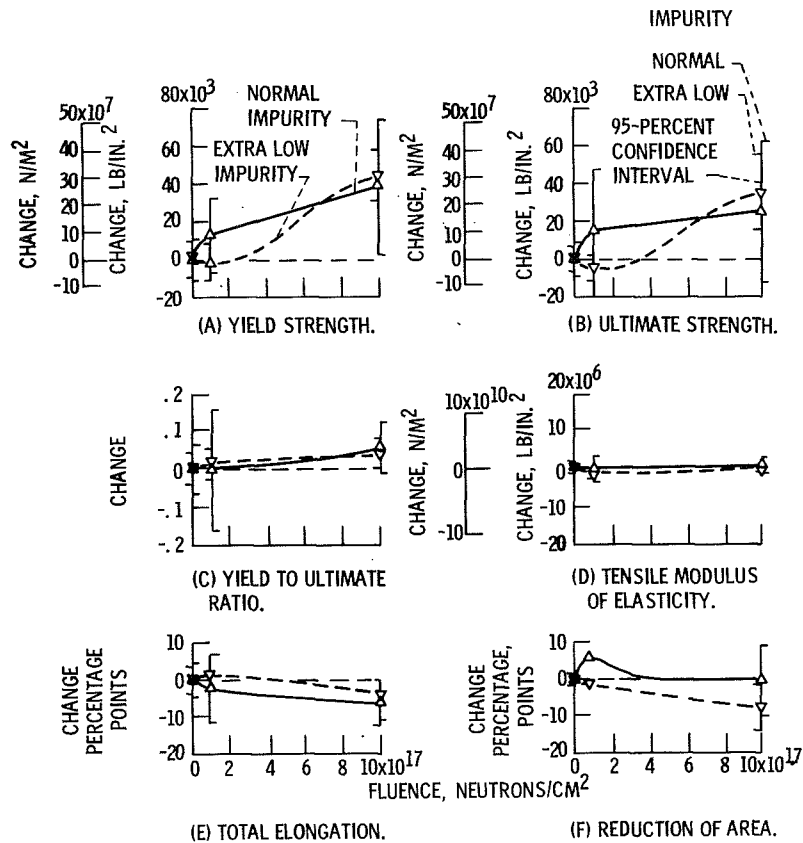

Figure 7. - Effect of reactor irradiation at 17 K on 17 K tensile properties of titanium - 5 aluminum - 2.5 tin alloy. Neutron energy  $>0.5$  MeV (80 fJ).

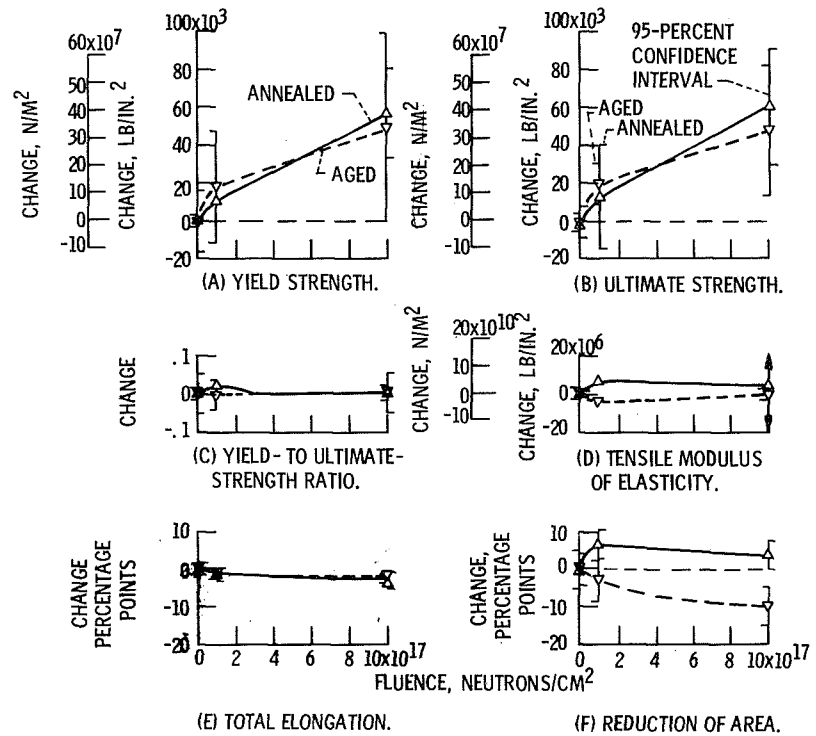

Figure 8. - Effect of reactor irradiation at 17 K on 17 K tensile properties of titanium - 6 aluminum - 4 vanadium alloy. Neutron energy  $>0.5$  MeV (80 fJ).

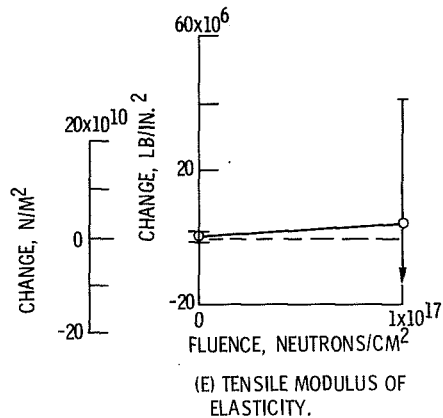
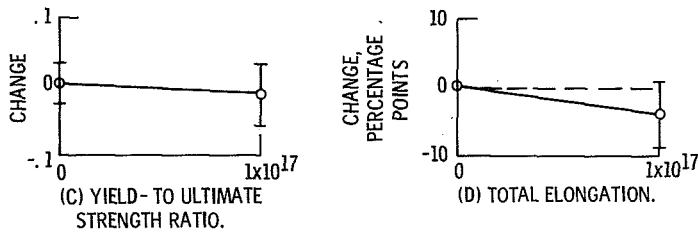
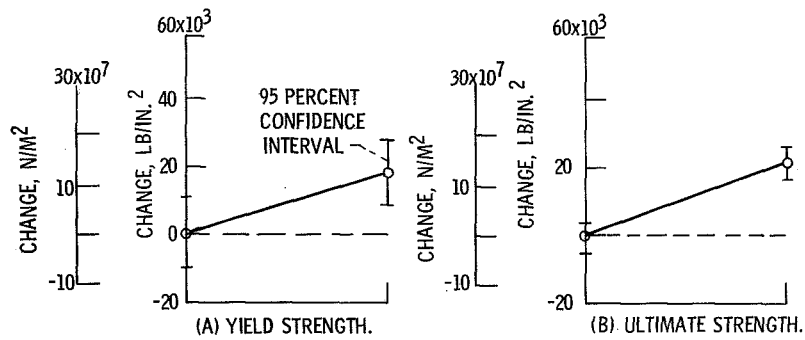

Figure 9. - Effect of reactor irradiation at 17 K on 17 K tensile properties of titanium - 8 aluminum - 1 molybdenum - 1 vanadium alloy. Neutron energy > 0.5 MeV (80 fJ).

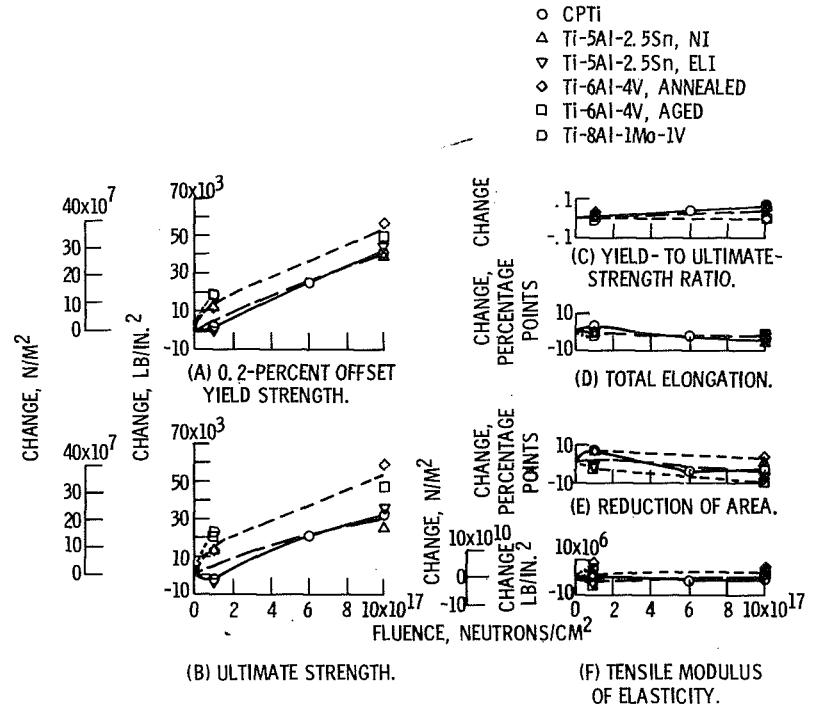

Figure 10. - Effect of reactor irradiation at 17 K on 17 K tensile properties of titanium and titanium-base alloys. Neutron energy > 0.5 MeV (80 fJ).