

General Disclaimer

One or more of the Following Statements may affect this Document

- This document has been reproduced from the best copy furnished by the organizational source. It is being released in the interest of making available as much information as possible.
- This document may contain data, which exceeds the sheet parameters. It was furnished in this condition by the organizational source and is the best copy available.
- This document may contain tone-on-tone or color graphs, charts and/or pictures, which have been reproduced in black and white.
- This document is paginated as submitted by the original source.
- Portions of this document are not fully legible due to the historical nature of some of the material. However, it is the best reproduction available from the original submission.

FACILITY FORM 802

<u>N71-14173</u> (ACCESSION NUMBER)	_____
<u>30</u> (PAGES)	<u>63</u> (THRU)
<u>TMX 66512</u> (NASA CR OR TMX OR AD NUMBER)	<u>19</u> (CODE)
	<u>19</u> (CATEGORY)



ELECTRONICS RESEARCH CENTER

NATIONAL AERONAUTICS AND SPACE ADMINISTRATION

PM-105

POLYNOMIAL MATRICES,
REPRESENTATIONS, AND
LINEAR SYSTEM THEORY

By William A. Wolovich
Electronics Research Center
Cambridge, Massachusetts

March 1970

This publication contains information prepared in the interest of rapid dissemination to a select distribution. The reader is cautioned that the information contained herein is preliminary in nature and subject to change.

NATIONAL AERONAUTICS AND SPACE ADMINISTRATION

1. Introduction

Controllability, observability, state feedback, state estimation, and the notion of transfer matrix realization are all basically time domain concepts which have played an important role in the evolution of "modern control theory" ; i.e. the analysis and design of dynamical systems via state space techniques. The primary purpose of this paper will be to present frequency domain analogies of these concepts in order to provide additional insight into the structure of linear systems, as well as offer alternative procedures for the analysis and design of linear multivariable systems. The reader should be aware at the outset that the results which will be presented here represent a natural extension of those presented in [1]. Consequently, a clear understanding of the main ideas presented in [1] would prove most helpful in reading this paper.

The manipulation of polynomial matrices will also play a key role in the development employed. Therefore, several definitions and preliminary results regarding this class of matrices are given in section 2. In section 3, a basic result involving a frequency domain characterization of linear systems is proved. This result, which we will call a representation theorem for a rational transfer matrix employs polynomial matrices and is analogous to the time domain concept of a realization for a rational transfer matrix. The utility of this result, from the point of view of obtaining realizations, is then demonstrated in section 4.

A practical application of transfer matrix representations is made in section 5, which deals with the frequency domain analog of state feedback and estimation. Two examples are presented in order to clarify the various results presented throughout the paper, and some concluding remarks are then made in section 6.

2. Definitions and Preliminary Results

A polynomial matrix, $P(s)$, is any matrix whose elements are polynomials (in this case in the Laplace variable s). The degree of $P(s)$ is defined as the degree of the polynomial or polynomials of highest degree comprising $P(s)$. We will consider only finite degree polynomial matrices in this paper.

The following three elementary operations on $P(s)$ may be defined:

- i) Interchange of rows (columns) i and j
- ii) Multiplication of row (column) i by a nonzero scalar
- iii) Replacement of row (column) i by itself plus any polynomial $p(s)$ times any other row (column) j

An elementary matrix, $E(s)$, will be defined as any matrix which can be obtained from the identity matrix, I , by a finite number of elementary operations on I . Note that the determinant of any elementary matrix is therefore a nonzero scalar. Later we will show that any polynomial matrix whose determinant is a nonzero scalar is an elementary matrix (see Proposition 1).

A polynomial matrix, $P(s)$, will be called equivalent to another polynomial matrix, $M(s)$, if and only if $P(s)$ can be " reduced " to $M(s)$ by a finite number of elementary operations on $P(s)$; i.e. if and only if there are two elementary matrices, $E_1(s)$ and $E_2(s)$, such that $E_1(s)P(s)E_2(s) = M(s)$. Equivalence will be represented by the symbol \sim ; i.e. $P(s) \sim M(s)$.

The rank of a polynomial matrix is defined as in the case of constant matrices; namely, the rank of $P(s)$ is equal to the dimension of the largest minor of $P(s)$ with nonzero determinant. A square polynomial matrix will be called nonsingular if and only if its determinant is nonzero. The determinant of $P(s)$ will be written as $|P(s)|$. The inverse of a nonsingular polynomial matrix will be written as $P(s)^{-1}$ or as $P(s)^+ / |P(s)|$, where $P(s)^+$ represents the adjoint of $P(s)$. Note that the only polynomial matrices, whose inverses are polynomial matrices, are elementary matrices. Furthermore, the adjoint of a polynomial matrix is a polynomial matrix.

We now introduce the concepts of column proper (and row proper) polynomial matrices. In particular, let d_{ci} denote the degree of the i -th column (an $m \times 1$ matrix) of the $m \times m$ matrix $P(s)$. Then $P(s)$ is of the form,

$$P(s) = \begin{bmatrix} p_{11}s^{d_{c1}} + \dots & p_{12}s^{d_{c2}} + \dots & \dots & p_{1m}s^{d_{cm}} + \dots \\ p_{21}s^{d_{c1}} + \dots & \vdots & \dots & \vdots \\ \vdots & \vdots & \dots & \vdots \\ p_{m1}s^{d_{c1}} + \dots & \vdots & \dots & p_{mm}s^{d_{cm}} + \dots \end{bmatrix}$$

where the + ... denotes lower degree terms in s . Let Γ be the constant $m \times m$ matrix $[p_{ij}]$, and $\text{diag}[s^{d_{ci}}]$ the diagonal matrix with entries $s^{d_{ci}}$. If $P^C(s)$ is now defined as $\Gamma \text{diag}[s^{d_{ci}}]$, it can be verified by induction that $|P(s)| = \|\Gamma\|s^p + \text{lower degree terms in } s$, where $p = \sum_1^m d_{ci}$. It is obvious that $|P^C(s)| = \gamma s^p$, where $\gamma = \|\Gamma\|$.

$P(s)$ will be called column proper if and only if the scalar $\gamma \neq 0$. Note that the "dual" concept of a row proper polynomial matrix can be defined in an analogous manner; i.e. $P(s)$ is row proper if and only if its transpose, $P^T(s)$, is column proper.

Proposition 1 : Any $(m \times m)$ nonsingular polynomial matrix, $P(s)$, can be reduced to a column (row) proper matrix, $\tilde{P}(s)$, by a finite number of elementary column (row) operations.[†]

Proof: If $|P^C(s)| \neq 0$, $P(s)$ would, by definition, be column proper and we would be done. On the other hand, suppose $|P^C(s)| = 0$; i.e. $\gamma = 0$. This would imply that the m column vectors comprising $P^C(s)$ were linearly dependent over the monomials in s ; i.e. if $P_i^C(s)$ represents the i -th column of $P^C(s)$, then $|P^C(s)| = 0$ would imply that

$$\sum_1^m p_i(s) P_i^C(s) = 0 \quad (1)$$

for two or more nonzero monomials $p_i(s)$, $i = 1, 2, \dots, m$. At least one of these monomials can be altered to unity by dividing (1) by a nonzero monomial of lowest degree, $p_k(s)$; i.e.

$$\sum_{i=1}^m (p_i(s)/p_k(s)) P_i^C(s) = \sum_1^m \tilde{p}_i(s) P_i^C(s) = 0 \quad (2)$$

[†] Note that we need only establish this proposition for the case of column proper reduction - the proof for row proper reduction follows directly by duality.

where $\tilde{p}_k(s) = 1$. The replacement of column k of $P^C(s)$ by (2) is analogous to postmultiplying $P^C(s)$ by the elementary matrix $E_1(s)$, where $E_1(s)$ is the identity matrix with an altered k -th column; i.e.

$$E_1(s) = \begin{bmatrix} 1 & 0 & \dots & \tilde{p}_1(s) & 0 & \dots & 0 \\ 0 & 1 & \dots & \tilde{p}_2(s) & 0 & \dots & 0 \\ \vdots & 0 & 1 & \vdots & \vdots & \vdots & \vdots \\ \vdots & \vdots & \vdots & 1 & \vdots & \vdots & \vdots \\ \vdots & \vdots & \vdots & \tilde{p}_{k+1}(s) & \vdots & \vdots & \vdots \\ \vdots & \vdots & \vdots & \vdots & \vdots & \vdots & \vdots \\ 0 & \dots & \tilde{p}_m(s) & 0 & \dots & 1 \end{bmatrix} \quad (3)$$

where at least one of the $\tilde{p}_i(s)$, $i \neq k$, is nonzero. Postmultiplying $P^C(s)$ by $E_1(s)$ results in a zero k -th column of the product; i.e. if

$$P^{C1}(s) = P^C(s)E_1(s), \quad (4)$$

then $P^{C1}(s)$ is equal to $P^C(s)$ except for a zero k -th column. Now let

$$P_1(s) = P(s)E_1(s) \quad (5)$$

$P_1(s)$, thus defined, is equal to $P(s)$ with an altered k -th column. In particular, the degree of the k -th column of $P_1(s)$ is strictly less than d_{ck} , the degree of the k -th column of $P(s)$. Consequently, $P_1(s)$ is a new candidate for a column proper matrix; i.e. $|P_1^C(s)| = \gamma_1 s^{p_1} + \text{lower degree terms in } s$, where p_1 is strictly less than p . It should now be obvious that if $\gamma_1 = 0$, this procedure can be repeated as many times as necessary to produce (for some j) a nonzero γ_j . Then $\tilde{P}(s) = P(s) \prod_1^j E_i(s) = P(s)\tilde{E}(s)$, where $\tilde{E}(s) = \prod_1^j E_i(s)$, thus establishing the proposition.

Earlier in this section, we stated that any polynomial matrix whose determinant is a nonzero scalar is an elementary matrix. This fact can now be easily established using Proposition 1. In particular, note that if $|P(s)|$ were a nonzero scalar, then $\tilde{P}(s) = P(s)\tilde{E}(s)$, where $\tilde{P}(s)$ would, by the above arguments, be a constant matrix \tilde{P} . Therefore, $P(s) = \tilde{P}\tilde{E}^{-1}(s)$, and since any constant nonsingular matrix is an elementary matrix by definition, $P(s)$, the product of two elementary matrices, is itself an elementary matrix.

We now make use of the Smith canonical form for polynomial matrices. Employing a definition due to Rosenbrock,^[2] we will call two polynomial matrices, $P_1(s)$ and $P_2(s)$, of dimensions $p \times m$ and $m \times m$ respectively, relatively prime, if and only if the Smith canonical form of the composite $(p + m) \times m$ matrix $\begin{bmatrix} P_2(s) \\ P_1(s) \end{bmatrix}$ is $\begin{bmatrix} I_m \\ 0 \end{bmatrix}$; i.e. if and only if there exist two elementary matrices, $E_1(s)$ and $E_2(s)$, of dimensions $p + m$ and m respectively, such that:

$$E_1(s) \begin{bmatrix} P_2(s) \\ P_1(s) \end{bmatrix} E_2(s) = \begin{bmatrix} I_m \\ 0 \end{bmatrix} \quad (6)$$

A fundamental result pertaining to relatively prime polynomial matrices can now be established, namely:

Proposition 2: Let $P_1(s)$ and $P_2(s)$ be relatively prime polynomial matrices of dimensions $p \times m$ and $m \times m$ respectively. Given any arbitrary $m \times m$ polynomial matrix $M(s)$, there exist polynomial matrices, $M_1(s)$ and $M_2(s)$, of dimensions $m \times p$ and $m \times m$ respectively, such that

$$M_1(s)P_1(s) + M_2(s)P_2(s) = M(s) \quad (7)$$

Proof: We make direct use of the definition of relatively prime polynomial matrices; i.e. partition $E_1(s)$ of (6) into four submatrices, namely

$$E_1(s) = \begin{bmatrix} E_{11}(s) & E_{12}(s) \\ E_{21}(s) & E_{22}(s) \end{bmatrix} \quad (8)$$

where $E_{11}(s)$ is $m \times m$, $E_{12}(s)$ is $m \times p$, $E_{21}(s)$ is $p \times m$, and $E_{22}(s)$ is $p \times p$. Equations (8) and (6) then imply that $[E_{11}(s)P_2(s) + E_{12}(s)P_1(s)]E_2(s) = I_m$. Since $E_2(s)$ is an elementary matrix, we can postmultiply the above by the inverse of $E_2(s)$ and premultiply by $E_2(s)$ to obtain:

$$E_2(s)E_{11}(s)P_2(s) + E_2(s)E_{12}(s)P_1(s) = I_m \quad (9)$$

Premultiplying the above by $M(s)$ establishes the desired result; i.e. equation (7), where

$$M(s)E_2(s)E_{12}(s) = M_1(s) \quad (10)$$

and

$$M(s)E_2(s)E_{11}(s) = M_2(s) \quad (11)$$

3. Realizations and Representations

The definitions and preliminary results on polynomial matrices established in the previous section will now be used to provide a rather natural analogy between time domain and frequency domain "factorizations" of linear systems. In particular, consider the following time domain (state space) description of a linear system:

$$\dot{x} = Ax + Bu ; y = Cx \quad (12)$$

where x is an n -vector, called the state, u is an m -vector, called the input, y is a p -vector, called the output, and A , B , and C are constant matrices of the appropriate dimensions. The triple $\{A, B, C\}$ will be used as an alternate characterization of the system (12). If we take the Laplace transform of (12), and solve for $y(s)$ in terms of $u(s)$, assuming zero initial conditions on the state x , we readily obtain an expression for the transfer matrix[†], $T(s)$, of the system in terms of the triple $\{A, B, C\}$; i.e.

$$y(s) = T(s)u(s), \quad (13)$$

where

$$T(s) = C(sI - A)^{-1}B \quad (14)$$

Note that $T(s)$ is a $p \times m$ matrix of "proper" transfer functions; i.e. a proper transfer matrix. The term proper implies that each of the (pm) transfer functions comprising $T(s)$ satisfies the condition that the degree of any numerator polynomial is strictly less than that of the corresponding denominator polynomial. If the degree of the numerator polynomial were allowed to be less than or equal to that of the denominator polynomial, the term realizable would be

[†]We will assume throughout this paper that all possible pole-zero cancellations have been made when speaking of transfer matrices.

used rather than proper. We will say more about realizable transfer matrices in section 5.

Clearly, every system triple, $\{A, B, C\}$, yields a unique transfer matrix via (14). However, the converse is not true; i.e. given any proper transfer matrix, $T(s)$, one can readily characterize an entire class of triples which yield $T(s)$ via (14).^[1] Any such triple will be called a realization of $T(s)$ of dimension n , where n is the dimension of the A matrix. A realization of $T(s)$ of lowest possible dimension \hat{n} , denoted $\{\hat{A}, \hat{B}, \hat{C}\}$, will be called a minimal realization.

The question of obtaining minimal realizations of proper transfer matrices has been the subject of numerous investigations,^{[1][3][4][5]} and it is well known that:

- i) Any proper transfer matrix, $T(s)$, does have a minimal realization, $\{\hat{A}, \hat{B}, \hat{C}\}$, of dimension \hat{n} .
- ii) If $\{\hat{A}, \hat{B}, \hat{C}\}$ is a minimal realization of $T(s)$, then the pair $\{\hat{A}, \hat{B}\}$ is completely controllable, and the pair $\{\hat{A}, \hat{C}\}$ is completely observable.

The purpose of this section is to introduce a frequency domain concept which is analogous to the time domain concept of realizations of transfer matrices. In subsequent sections we will discuss and illustrate the utility of this concept. In particular, we define a controllable representation[†] of a $p \times m$ transfer matrix, $T(s)$, as any pair, $\{P_1(s), P_2(s)\}$, of polynomial matrices which satisfies the relationship:

$$T(s) = P_1(s)P_2^{-1}(s) \quad (15)$$

Clearly, $P_1(s)$ and $P_2(s)$ have dimensions $p \times m$ and $m \times m$ respectively. The order of a controllable representation will be defined as the degree of $|P_2(s)|$. The pair, $\{\hat{P}_1(s), \hat{P}_2(s)\}$, will be called a minimal controllable representation of $T(s)$ if and only if:

- i) The pair, $\{\hat{P}_1(s), \hat{P}_2(s)\}$, satisfies (15), and
- ii) a controllable representation of $T(s)$ of order lower than that of $\{\hat{P}_1(s), \hat{P}_2(s)\}$ does not exist.

In a dual fashion, we define an observable representation of a $p \times m$ transfer

[†]In the next section, we will demonstrate how to obtain a controllable realization from a controllable representation.

matrix, $T(s)$, as any pair, $\{Q_1(s), Q_2(s)\}$ of polynomial matrices which satisfies the relationship:

$$T(s) = Q_1^{-1}(s)Q_2(s) \quad (16)$$

Clearly, $Q_1(s)$ and $Q_2(s)$ have dimensions $p \times p$ and $p \times m$ respectively. The order of an observable representation will be defined as the degree of $|Q_1(s)|$. The pair, $\{\hat{Q}_1(s), \hat{Q}_2(s)\}$, will be called a minimal observable representation of $T(s)$ if and only if:

- i) The pair, $\{\hat{Q}_1(s), \hat{Q}_2(s)\}$, satisfies (16), and
- ii) an observable representation of $T(s)$ of order lower than that of $\{\hat{Q}_1(s), \hat{Q}_2(s)\}$ does not exist.

One additional definition is required prior to the establishment of a basic result of this paper. In particular, we recall that any proper $p \times m$ transfer matrix, $T(s)$, has a minimal realization, $\{\hat{A}, \hat{B}, \hat{C}\}$, of dimension \hat{n} . If \hat{B} is of full rank m , and \hat{C} of full rank p , the transfer matrix, $T(s)$, will be called full rank proper. The majority of physical systems with proper transfer matrices do satisfy this full rank condition, and most of our attention will focus on such systems.

We will now establish a theorem basic to the structure of linear multivariable systems and analogous to known results pertaining to time domain realizations of transfer matrices.

Theorem 1: Any $p \times m$ full rank proper transfer matrix, $T(s)$, has a minimal controllable (observable) representation, $\{\hat{P}_1(s), \hat{P}_2(s)\}$ ($\{\hat{Q}_1(s), \hat{Q}_2(s)\}$).

Furthermore, any such minimal representation satisfies the conditions:

- i) If $\{\hat{A}, \hat{B}, \hat{C}\}$ is a minimal realization of $T(s)$, then $|\hat{P}_2(s)|$ ($|\hat{Q}_1(s)|$) divides and is divided by $|sI - \hat{A}|$.
- ii) $\hat{P}_1(s)$ and $\hat{P}_2(s)$ ($\hat{Q}_1(s)$ and $\hat{Q}_2(s)$) are relatively prime polynomial matrices.

Proof: The proof of this theorem involves a combination of results. The first

[†]As in the case of Proposition 1, we need only establish this theorem for the case of controllable representations. Duality can then be employed.

of these, the structure theorem^[1] has been established elsewhere, and is repeated here for convenience as the first lemma; i.e.

Lemma 1: Any $p \times m$ full rank proper transfer matrix, $T(s)$, can be written as:

$$T(s) = \hat{C}S(s) [\hat{B}_m^{-1} \delta(s)]^{-1} \quad (17)$$

where $\hat{C}S(s)$ and $\hat{B}_m^{-1} \delta(s)$ are $p \times m$ and $m \times m$ polynomial matrices respectively.

Furthermore, if $\{\hat{A}, \hat{B}, \hat{C}\}$ is a minimal realization of $T(s)$, then $|\hat{B}_m^{-1} \delta(s)| = |sI - \hat{A}|$.

The proof of this lemma and the definitions of \hat{C} , $S(s)$, $\delta(s)$, and \hat{B}_m are given in [1], and will not be repeated here. Furthermore, for convenience, we will let $\tilde{P}_1(s) = \hat{C}S(s)$, and $\tilde{P}_2(s) = \hat{B}_m^{-1} \delta(s)$; i.e. by (17) then, we can write $T(s) = \tilde{P}_1(s)$ times $\tilde{P}_2^{-1}(s)$.

The second result we will employ is, itself, a useful result, namely:

Lemma 2: If $\{P_1(s), P_2(s)\}$ is an n -th order controllable representation of $T(s)$, there exists an n -th order controllable realization $\{A, B, C\}$ of $T(s)$.

A constructive proof of this result will be postponed until section 4, which deals with techniques for obtaining realizations from representations.

We note here that Lemmas 1 and 2 can be employed to establish most of Theorem 1. In particular, Lemma 1 establishes the fact that every full rank proper transfer matrix does have a controllable representation, namely $\{\tilde{P}_1(s), \tilde{P}_2(s)\}$, and therefore a minimal controllable representation $\{\hat{P}_1(s), \hat{P}_2(s)\}$. We will, in fact, now establish that $\{\tilde{P}_1(s), \tilde{P}_2(s)\}$ is a minimal controllable representation. To do this, note that $\{\tilde{P}_1(s), \tilde{P}_2(s)\}$ is of order \hat{n} , since $|\tilde{P}_2(s)| = |sI - \hat{A}|$, where \hat{A} determines a minimal realization of $T(s)$ of order \hat{n} . By Lemma 2, a controllable representation of $T(s)$ of order less than \hat{n} can not exist, since this would imply the existence of a corresponding realization of $T(s)$ of order less than \hat{n} , which is impossible. Therefore, the pair $\{\tilde{P}_1(s), \tilde{P}_2(s)\}$ is a minimal controllable representation of $T(s)$.

Lemma 3: Consider the minimal controllable representation, $\{\tilde{P}_1(s), \tilde{P}_2(s)\}$, of $T(s)$ introduced in Lemma 1. The Smith canonical form of $\begin{bmatrix} \tilde{P}_2(s) \\ \tilde{P}_1(s) \end{bmatrix}$ is $\begin{bmatrix} I \\ 0^m \end{bmatrix}$; i.e.

$\tilde{P}_1(s)$ and $\tilde{P}_2(s)$ are relatively prime.

Proof: By Lemma 1, $|\tilde{P}_2(s)| = |sI - \hat{A}|$, where \hat{A} is a member of a minimal realization of $T(s)$. Using this fact, one need only repeat the arguments of Rosenbrock^[6] to establish Lemma 3.

Lemmas 1, 2, and 3 establish the fact that given any $p \times m$ full rank proper transfer matrix, $T(s)$, one can find a minimal controllable representation of $T(s)$, namely $\{\tilde{P}_1(s), \tilde{P}_2(s)\}$, which satisfies the two conditions of Theorem 1. All that remains to be shown is that any minimal controllable representation of $T(s)$ also satisfies these two conditions. We do this by establishing an equivalence relationship between minimal representations, namely:

Lemma 4: If $\{P_1(s), P_2(s)\}$ is a controllable representation of the $p \times m$ full rank proper transfer matrix, $T(s)$, and $\{\hat{P}_1(s), \hat{P}_2(s)\}$, a minimal controllable representation of $T(s)$, then there exists a nonsingular polynomial matrix, $R(s)$, such that $P_1(s) = \hat{P}_1(s)R(s)$, and $P_2(s) = \hat{P}_2(s)R(s)$; i.e.

$$T(s) = P_1(s)P_2^{-1}(s) = \hat{P}_1(s)R(s)[\hat{P}_2(s)R(s)]^{-1} = \hat{P}_1(s)\hat{P}_2^{-1}(s) \quad (18)$$

Furthermore, $|R(s)|$ divides $|P_2(s)|$, and if $\{P_1(s), P_2(s)\}$ is a minimal controllable representation of $T(s)$, $R(s)$ is an elementary matrix.[†]

Proof: Write $T(s)$ as the product $\tilde{P}_1(s)\tilde{P}_2^{-1}(s)$ as given by Lemma 1. By Lemma 3, $\tilde{P}_1(s)$ and $\tilde{P}_2(s)$ are relatively prime. Hence,

$$T(s) = P_1(s)P_2^{-1}(s) = \tilde{P}_1(s)\tilde{P}_2^{-1}(s), \quad (19)$$

or

$$P_1(s) = \frac{\tilde{P}_1(s)\tilde{P}_2^+(s)P_2(s)}{|\tilde{P}_2(s)|} \quad (20)$$

Since $P_1(s)$ is a polynomial matrix, $|\tilde{P}_2(s)|$ must divide the product $\tilde{P}_1(s)\tilde{P}_2^+(s)P_2(s)$.

Now, by Proposition 2, we can find a pair of polynomial matrices, $\{M_1(s), M_2(s)\}$, such that:

$$M_1(s)\tilde{P}_1(s) + M_2(s)\tilde{P}_2(s) = I_m, \quad (21)$$

[†]This final lemma is also important in that it establishes the relationship between any controllable representation of a transfer matrix, and one of minimal order.

or,

$$M_1(s)\tilde{P}_1(s)\tilde{P}_2^+(s)P_2(s) + M_2(s)\tilde{P}_2(s)\tilde{P}_2^+(s)P_2(s) = \tilde{P}_2^+(s)P_2(s) \quad (22)$$

Since $\tilde{P}_2(s)\tilde{P}_2^+(s) = I\tilde{P}_2(s)I_m$, and since $I\tilde{P}_2(s)I$ divides the product $\tilde{P}_1(s)\tilde{P}_2^+(s)P_2(s)$, it follows that $I\tilde{P}_2(s)I_m$ can be factored from the left side of (22); thus $I\tilde{P}_2(s)I$ must also divide the right side of (22), namely $\tilde{P}_2^+(s)P_2(s)$. Consequently, the quotient $[\tilde{P}_2^+(s)P_2(s)/I\tilde{P}_2(s)I]$ is a polynomial matrix which we will call $R(s)$, or

$$\tilde{P}_2^{-1}(s)P_2(s) = R(s) \quad (23)$$

Therefore,

$$P_2(s) = \tilde{P}_2(s)R(s) \quad (24)$$

and from (20),

$$P_1(s) = \tilde{P}_1(s)R(s) \quad (25)$$

It now follows from (24) that $I\tilde{P}_2(s)I = I\tilde{P}_2(s)I \times IR(s)I$, or that $IR(s)I$ does divide $I\tilde{P}_2(s)I$. Furthermore, note that if $\{ P_1(s), P_2(s) \}$ were a minimal controllable representation of $T(s)$, then $I\tilde{P}_2(s)I$ would be a polynomial of degree \hat{n} , as would $I\tilde{P}_2^+(s)I$. Since we have just established the fact that $I\tilde{P}_2(s)I = I\tilde{P}_2^+(s)I \times IR(s)I$, this implies that $IR(s)I$ must be a polynomial of degree zero; i.e. a scalar. Consequently, if $\{ P_1(s), P_2(s) \}$ is a minimal controllable representation of $T(s)$, $R(s)$ must be an elementary matrix. Lemma 4 is thus established.

Therefore, since $\{ \tilde{P}_1(s), \tilde{P}_2(s) \}$ satisfies the two conditions of Theorem 1, any $\{ \hat{P}_1(s), \hat{P}_2(s) \} = \{ \tilde{P}_1(s)E(s), \tilde{P}_2(s)E(s) \}$ also satisfies these conditions by direct arguments. Theorem 1 is thus established.

To summarize thus far, we have introduced a new concept pertaining to the transfer matrix characterization of linear systems. This frequency domain concept, called a representation, is analogous to the time domain concept of realization. More specifically, we have shown that any full rank proper transfer matrix, $T(s)$, can be factored in three different "minimal" ways; i.e.

$$T(s) = \hat{C}(sI - \hat{A})^{-1}\hat{B} = \hat{P}_1(s)\hat{P}_2^{-1}(s) = \hat{Q}_1^{-1}(s)\hat{Q}_2(s) \quad (26)$$

All of these "factorizations" share certain common properties. In particular,

$|sI - \hat{A}|$, $|\hat{P}_2(s)|$, and $|\hat{Q}_1(s)|$ are all \hat{n} -th degree polynomials differing by, at most, a scalar multiplier. The word "minimal" associated with these three factorizations implies (as far as the quantity $\hat{C}(sI - \hat{A})^{-1}\hat{B}$ is concerned) that the pair $\{\hat{A}, \hat{B}\}$ is controllable, and the pair $\{\hat{A}, \hat{C}\}$ is observable. An analogous interpretation regarding the pairs $\{\hat{P}_1(s), \hat{P}_2(s)\}$ and $\{\hat{Q}_1(s), \hat{Q}_2(s)\}$ will be the subject of the next section, which deals with the derivation of realizations from representations.

4. The Derivation of Realizations from Representations

The results which have been presented thus far are primarily of academic interest; i.e. if one could obtain a controllable or observable representation of some transfer matrix, $T(s)$, it is not at all clear how such a representation could then be used for the purpose of analysis or design. The remainder of this paper will focus on such practical considerations. Before presenting any direct utilization of representations however, it will be of interest to consider the relationship between realizations and representations.

For reasons which will become more obvious as we progress, we will first consider the question of converting from a representation[†] to a realization. In particular, we will demonstrate constructively how one can always obtain an n -th order realization from an n -th order representation, thus establishing Lemma 2 of the previous section.

Consider the n -th order representation, $\{P_1(s), P_2(s)\}$, of the full rank proper transfer matrix $T(s)$; i.e. $|P_2(s)|$ is a polynomial of degree n . By Proposition 1 (section 2), $P_2(s)$ can be reduced to column proper form via some elementary matrix $E^*(s)$. Call the resulting column proper matrix $P_2^*(s)$; i.e.

$$P_2^*(s) = P_2(s)E^*(s) \quad (27)$$

Let $P_1^*(s) = P_1(s)E^*(s)$, and note that

$$T(s) = P_1^*(s)P_2^{*-1}(s) \quad (28)$$

[†]Again, we will deal primarily with controllable representations--by duality, analogous results hold for the case of observable representations.

$\{ P_1^*(s), P_2^*(s) \}$ is also a controllable representation of $T(s)$ of order n .

Define G^* as the constant $m \times m$ matrix consisting of the coefficients of the highest degree s term or terms in each column of $P_2^*(s)$ (G^* is analogous to the matrix Γ defined in section 2). G^* is nonsingular since $|P_2^{*c}(s)|$ is a nonzero monomial. If $P_2^*(s)$ is premultiplied by G^{*-1} , the resulting polynomial matrix, which we will call $D(s)$, is characterized by the fact that the highest degree s term in each (i -th) column of $D(s)$ appears in the corresponding (i -th) row with unity coefficient; i.e.

$$D(s) = G^{*-1} P_2^*(s) \quad (29)$$

where $D(s)$ can also be written as:

$$D(s) = D^c(s) - A_m S(s), \quad (30)$$

where $D^c(s)$ is a diagonal matrix with entries s^{σ_i} , $i = 1, 2, \dots, m$. The σ_i have a special interpretation which is more thoroughly discussed in [1]. A_m is an $m \times n$ constant matrix whose elements are directly determined by (29) and (30), and $S(s)$ is an $n \times m$ matrix of monic monomials in s . In particular,

$$S(s) = \begin{bmatrix} 1 & 0 & 0 & \dots & 0 \\ s & 0 & 0 & & \vdots \\ \vdots & \vdots & \vdots & & \vdots \\ s^{\sigma_1-1} & 1 & \dots & & 0 \\ 0 & s & & & \vdots \\ \vdots & \vdots & & & \vdots \\ \vdots & s^{\sigma_2-1} & \dots & & \vdots \\ & 0 & & & \vdots \\ & \vdots & & & \vdots \\ 0 & 0 & \dots & & s^{\sigma_m-1} \end{bmatrix} \quad (31)$$

We can write $T(s)$ as the product:

$$T(s) = P_1^*(s) [G^* G^{*-1} P_2^*(s)]^{-1} = P_1^*(s) D^{-1}(s) G^{*-1} \quad (32)$$

This expression for $T(s)$ admits a direct time domain realization $\{ A, B, C \}$ by

virtue of the results given in [1]. In particular, $P_1^*(s)$ is analogous to $\hat{C}S(s)^{[1]}$, $D(s)$ to $\delta(s)^{[1]}$, and G^{*-1} to $\hat{B}_m^{[1]}$.

More specifically, an n -th order realization, $\{A, B, C\}$, of $T(s)$ can be obtained as follows; An appropriate $p \times n$ matrix C can be found directly by inspection, since $P_1^*(s)$ can be written as $CS(s)^{[1]}$, where $S(s)$ is given by (31). Now define $d_k = \sum_1^k \sigma_i$ as in [1]. Note that $d_m = n$. Replace the (m) d_k -th rows of an n dimensional companion matrix by the ordered (m) rows of A_m , where A_m is given directly by (30) in much the same way as C was obtained. The resulting matrix is an A corresponding to the above choice for $C^{[1]}$. Similarly, replace the (m) d_k -th rows of an $n \times m$ null matrix by the ordered (m) rows of the $m \times m$ nonsingular matrix G^{*-1} . The resulting matrix is a B corresponding to the A and C already selected. The triple $\{A, B, C\}$, thus obtained, is a controllable realization of $T(s)$ obtained from the controllable representation, $\{P_1(s), P_2(s)\}$, of $T(s)$. Herein lies the motivation for associating the word "controllable" with a representation which factors as $P_1(s)P_2^{-1}(s)$. By duality, one could obtain an observable realization of $T(s)$, given an observable representation, $\{Q_1(s), Q_2(s)\}$, of $T(s)$. A simple algorithm to use is the one outlined above, only applied to the transpose of $T(s)$, and later transposed again; i.e. $T^T(s) = Q_2^T(s)Q_1^{-T}(s)$ would yield an observable triple (realization), $\{A^T, C^T, B^T\}$.

The algorithm which we have just outlined for obtaining realizations from representations is just that, an algorithm. The reader should really be completely familiar with the results given in [1] in order to interpret it as a constructive proof of Lemma 4.

So far, we have discussed certain implications associated with certain representations of $T(s)$. However, we have not discussed a more fundamental question, namely how to obtain representations; i.e. factorizations of $T(s)$ as either the product $P_1(s)P_2^{-1}(s)$ or $Q_1^{-1}(s)Q_2(s)$. Also, we have not presented any methods for determining whether or not a particular representation is min-

imal. Some discussion of these questions appears to be in order.

First, we remark that in general, the problem of finding a representation of $T(s)$ is analogous to that of finding a realization of $T(s)$. In fact, the algorithm just outlined allows one to rather easily obtain an n -th order realization from an n -th order representation of $T(s)$. The converse is also straightforward and is one of the results presented in [1]. We might also remark that it is relatively easy to obtain either a realization or a representation of a given transfer matrix provided minimality is not important. Unfortunately, in most applications, minimality is a key concept, since it is tied to controllability and observability of the system under consideration. In the case of realizations, "reducing" any n -th order realization to an \hat{n} -th (minimal) order one involves some rather intricate computations.^[1] An analogous condition holds in the case of representations as one might expect; i.e. as previously shown - see Lemma 4 - if a controllable representation $\{ P_1(s), P_2(s) \}$ is not minimal, there exists a nonsingular polynomial matrix, $R(s)$, which can be postmultiplied (factored) out of both $P_1(s)$ and $P_2(s)$ to produce a minimal controllable representation.

The development of algorithms for determining when two polynomial matrices are relatively prime, finding postfactors such as $R(s)$, and factoring polynomial matrices has and will continue to be the subject of further investigations. Some interesting results have already been obtained.^{[2][6][7]}

5. Feedback Compensation

In this section, we will present an application of the methodology developed in the previous sections. In particular, we will outline a (frequency domain) feedback compensation technique for linear systems in order to achieve some desired closed loop transfer matrix. An analogy between this technique and (time domain) state estimation and feedback will then be made and demonstrated by example.

To begin, consider any controllable representation, $\{ P_1(s), P_2(s) \}$, of $T(s)$, where $P_2(s)$ is assumed (for convenience) to be column proper and equal to $G^*D(s)$ (see eqs. (29) and (30)). Suppose we desire the " closed loop " transfer matrix $T_F(s)$, where

$$T_F(s) = P_1(s)P_{2F}^{-1}(s), \quad (33)$$

and

$$P_{2F}(s) = P_2(s) - FS(s), \quad (34)$$

$S(s)$ is given by (31), and F is an $m \times n$ constant matrix. We will call the pair $\{ P_1(s), P_{2F}(s) \}$, a closed loop controllable representation of the transfer matrix[†].

Let us now consider a design procedure which will produce this desired closed loop transfer matrix under the appropriate conditions. In particular, consider the following block diagram, which represents feedback compensation for the system whose open loop transfer matrix $T(s) = P_1(s)P_2^{-1}(s)$; i.e.

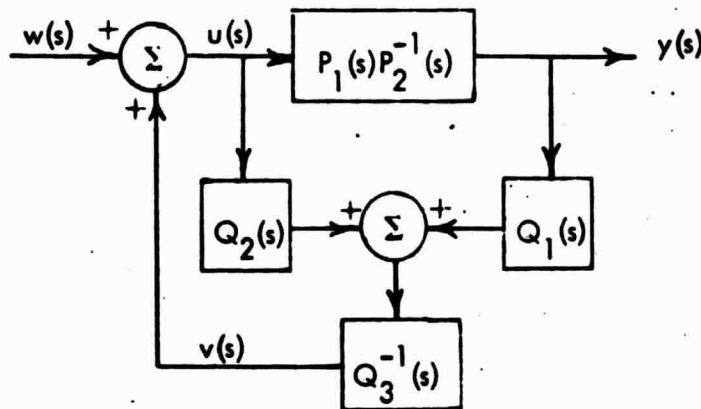

Figure 1

Frequency Domain Estimation

We define a frequency domain estimator of $FS(s) = P_2(s) - P_{2F}(s)$, as a triple $\{ Q_1(s), Q_2(s), Q_3(s) \}$, of polynomial matrices of dimensions $m \times p$, $m \times m$, and $m \times m$ respectively, which satisfies the following three conditions:

[†]The motivation for this terminology will become more apparent when we later relate F to closed loop " state " feedback in the time domain.

- (i) $Q_3(s)$ is nonsingular, and $|Q_3(s)|$ is Hurwitz; i.e. the roots of $|Q_3(s)|$ lie in the half-plane $\text{Re } s < 0$.
- (ii) $Q_3^{-1}(s) [Q_2(s), Q_1(s)]$ is a realizable (section 3) $m \times (m+p)$ transfer matrix; relating the Laplace transform of the output, $v(s)$, of the estimator, to the Laplace transform of the input $\begin{bmatrix} u(s) \\ y(s) \end{bmatrix}$.

(iii) The following relationship holds:

$$Q_3(s)FS(s) = Q_1(s)P_1(s) + Q_2(s)P_2(s) \quad (35)$$

The following important fact can now be established:

Theorem 2: The above three conditions which define a frequency domain estimator are sufficient to insure that the closed loop transfer matrix, $T_F(s)$, depicted in Figure 1; i.e. $y(s) = T_F(s)w(s)$, is equal to $P_1(s)P_{2F}^{-1}(s)$ as defined by eqs. (33) and (34).

Proof: Consider the equations implicit in Figure 1; i.e.

$$u(s) = w(s) + Q_3^{-1}(s)Q_2(s)u(s) + Q_3^{-1}(s)Q_1(s)y(s) \quad (36)$$

Also,

$$y(s) = P_1(s)P_2^{-1}(s)u(s) \quad (37)$$

Substituting (37) for $y(s)$ in (36) and collecting terms, we obtain:

$$[I - Q_3^{-1}(s) [Q_2(s) - Q_1(s)P_1(s)P_2^{-1}(s)]] u(s) = w(s), \quad (38)$$

or

$$Q_3^{-1}(s) [Q_3(s)P_2(s) - Q_2(s)P_2(s) - Q_1(s)P_1(s)] P_2^{-1}(s)u(s) = w(s) \quad (39)$$

If (35) is now used in (39), we obtain:

$$[P_2(s) - FS(s)] P_2^{-1}(s)u(s) = w(s), \quad (40)$$

or employing (33),

$$P_{2F}(s)P_2^{-1}(s)u(s) = w(s) \quad (41)$$

Since $P_{2F}(s)$ is nonsingular,^[1]

$$u(s) = P_2(s)P_{2F}^{-1}(s)w(s), \quad (42)$$

and using (37), we obtain the desired result; i.e.

$$y(s) = P_1(s)P_{2F}^{-1}(s)w(s) \quad (43)$$

which establishes the theorem.

To summarize, we have now shown how one can design a feedback compensation system (a frequency domain estimator) which produces a desired closed loop transfer matrix. Note that no specific reference to the "state" of the system has been made, nor has it been necessary. However, it is perhaps appropriate to now employ this concept in order to relate our results to known time domain results. In particular, there is a rather natural analog between the compensation scheme just presented and the time domain concepts of state estimation and feedback, as we will now show.

To begin, let us employ the algorithm given in section 4 to obtain a controllable realization $\{A, B, C\}$, of $T(s)$ corresponding to $\{P_1(s), P_2(s)\}$; i.e.

$$T(s) = P_1(s)P_2^{-1}(s) = C(sI - A)^{-1}B \quad (44)$$

Recalling the interpretation of the realization $\{A, B, C\}$ in the time domain via the differential equation (12), we will define state feedback (in the time domain) as the control law,

$$u = Fx + w, \quad (45)$$

where F is the $m \times n$ constant matrix given by (34), and w is an m -vector representing the external input to the system as indicated in Figure 2; i.e.

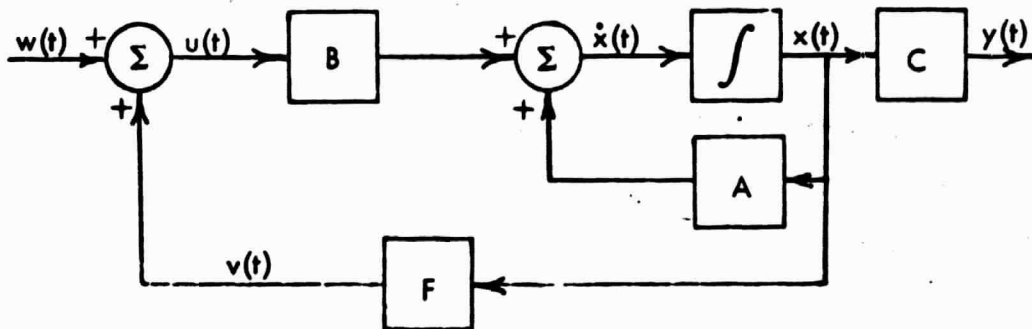

Figure 2

Closed Loop State Space System

Substituting (45) for u in (12) results in the closed loop system,

$$\dot{x} = (A + BF)x + Bw; \quad y = Cx \quad (46)$$

as represented by Figure 2.

The closed loop transfer matrix associated with this system is readily determined; i.e.

$$y(s) = \hat{T}_F(s)u(s), \quad (47)$$

where

$$\hat{T}_F(s) = C(sI - A - BF)^{-1}B \quad (48)$$

Equation (48) clearly contains a rather simple alteration of the original expression for the open loop transfer matrix as given by (14), namely the replacement of A by $A + BF$. The analogous interpretation of "state feedback" from the point of view of the controllable representation, $\{P_1(s), P_2(s)\}$, of $T(s)$ has already been made, namely the replacement of $P_2(s)$ by $P_{2F}(s)$ as given by (34). In short, from our analysis thus far and some rather elementary arguments given in [1], it follows that:

$$T_F(s) = \hat{T}_F(s) = C(sI - A - BF)^{-1}B = P_1(s)P_{2F}^{-1}(s) \quad (49)$$

State feedback in the time domain can therefore be directly related to a closed loop controllable representation of the transfer matrix.

State estimation in the time domain can similarly be related to frequency domain estimation. Due to spatial limitations however, we will not present a time domain characterization of state estimation here since we would only be repeating well known results.^{[8][9]} We should emphasize however, that in order to achieve a state feedback design (as depicted in Figure 2) when only the output y of the system is measurable, it is necessary to employ a technique such as state estimation or frequency domain estimation.

Note that we have thus far avoided any reference to the term "minimal" when discussing either realizations or representations of the systems under consideration in this section. It is, nevertheless, an important concept for the

following reason. In the case of time domain state estimation, it is well known that in order to construct a total state estimator, system observability is required^[8] i.e. the controllable realization $\{A, B, C\}$ we have been discussing, must also be observable, and hence minimal.^{[3][4]} Similarly, from the point of view of frequency domain estimation, a solution to (35) is guaranteed, regardless of the choice of $Q_3(s)$, provided the representation $\{P_1(s), P_2(s)\}$ is minimal; i.e. Theorem 1 then guarantees that $P_1(s)$ and $P_2(s)$ are relatively prime and hence that Proposition 2 holds.

A number of unresolved questions associated with this frequency domain approach to design remain which will require additional investigations. For example, nothing has been said regarding the increase in system order required to implement the frequency domain estimator. It might be desirable to keep the degree of $|Q_3(s)|$ (the order of the estimator) as low as possible. The problem of finding a triple $\{Q_1(s), Q_2(s), Q_3(s)\}$, which produces the desired closed loop transfer matrix is not a trivial task in the case of multivariable systems (the existence of such a triple depends on known time domain results^{[8][9]}). Unfortunately, we cannot answer all questions related to the implementation of frequency domain estimator feedback at this time. Under certain conditions, however, the construction and feedback utilization of frequency domain estimators is relatively simple and straightforward, and we will focus our attention on two such cases in this paper. In particular,

Case 1) Consider the case when:

- a) $P_1(s)$ is square and nonsingular
- b) $|P_1(s)|$ is a Hurwitz polynomial
- c) $FS(s)P_1^{-1}(s)$ is a realizable transfer matrix

If in (36), $Q_2(s)$ is set equal to zero and

$$FS(s)P_1^{-1}(s) = Q_3^{-1}(s)Q_1(s), \quad (50)$$

then substituting $FS(s)P_1^{-1}(s)$ for $Q_3^{-1}(s)Q_1(s)$ in (36) and employing (37) directly yields the relationship:

$$u(s) = w(s) \cdot FS(s)P_{2F}^{-1}(s)J(s), \quad (51)$$

or

$$[I - FS(s)P_2^{-1}(s)]u(s) = w(s), \quad (52)$$

from which equations (40) through (43) follow directly, thereby producing the desired closed loop transfer matrix $T_F(s) = P_1(s)P_{2F}^{-1}(s)$.

Example of Case 1 :

Suppose that

$$T(s) = \frac{\begin{bmatrix} s^3 - 3s^2 - 10s + 3, & s^3 + 3s \\ -3s^3 - s^2 + 3s - 17, & 2s^2 + 6 \end{bmatrix}}{s^4 + s^3 - 5s^2 + 3s} \quad (E1)$$

The reader can verify that a minimal controllable representation, $\{\hat{P}_1(s), \hat{P}_2(s)\}$, of $T(s)$ is the pair,

$$\hat{P}_1(s) = \begin{bmatrix} s + 3, & s \\ -3s - 7, & 2 \end{bmatrix}, \quad (E2)$$

where

$$|\hat{P}_1(s)| = 3s^2 + 9s + 6 = 3(s+1)(s+2), \quad (E3)$$

(note that conditions a and b defining Case 1 are thus satisfied)

and

$$\hat{P}_2(s) = \begin{bmatrix} s^2 + 3, & 0 \\ 4s + 5, & s^2 - 2s + 1 \end{bmatrix}, \quad (E4)$$

where

$$|\hat{P}_2(s)| = s^4 + s^3 - 5s^2 + 3s = s(s+3)(s-1) \quad (E5)$$

Remark: In this example, $\hat{P}_1(s)$ and $\hat{P}_2(s)$ can be obtained using the algorithm of Menahem^[7] to factor the numerator of $T(s)$.

Note that this open loop system is clearly unstable. Suppose we now wished an asymptotically stable "decoupled" closed loop system. Employing the results given in [1] and [10], we conclude that in this case, a $\hat{P}_{2F}(s)$ and G exist such that:

$$\hat{P}_1(s)\hat{P}_{2F}^{-1}(s)G = \begin{bmatrix} \frac{1}{s+4} & 0 \\ 0 & \frac{-3}{s+5} \end{bmatrix}, \quad (E6)$$

after all possible pole-zero cancellations have been made. We directly determine that:

$$G = \begin{bmatrix} 0 & 1 \\ 1 & -1 \end{bmatrix} \quad (E7)$$

Since $\hat{P}_1(s)$ and G are now known, we can solve (E6) for $\hat{P}_{2F}(s) = G \begin{bmatrix} s+4 & 0 \\ 0 & \frac{s+5}{-3} \end{bmatrix}$ times $\hat{P}_1(s)$, and for this example,

$$\hat{P}_{2F}(s) = \begin{bmatrix} s^2 + 22/3s + 35/3 & -2/3s - 10/3 \\ -1/3s + 1/3 & s^2 + 14/3s + 10/3 \end{bmatrix} \quad (E8)$$

$FS(s)$ is now given by (34); i.e.

$$FS(s) = \hat{P}_2(s) - \hat{P}_{2F}(s) = \begin{bmatrix} -22/3s - 26/3 & 2/3s + 10/3 \\ 13/3s + 14/3 & -20/3s - 7/3 \end{bmatrix} \quad (E9)$$

Solving for $FS(s)\hat{P}_1^{-1}(s)$ using (E2) and (E9), we obtain:

$$FS(s)\hat{P}_1^{-1}(s) = \frac{\begin{bmatrix} 2s^2 + 6 & 8s^2 + 14s + 10 \\ -20s^2 - 45s - 7 & -11s^2 - 27s - 7 \end{bmatrix}}{3(s+1)(s+2)} \quad (E10)$$

Clearly, $FS(s)\hat{P}_1^{-1}(s)$ is a realizable transfer matrix (condition c of Case 1 is thus satisfied), which, when substituted into the feedback path as indicated below in Figure E1, yields the desired closed loop transfer matrix as given by (E6).

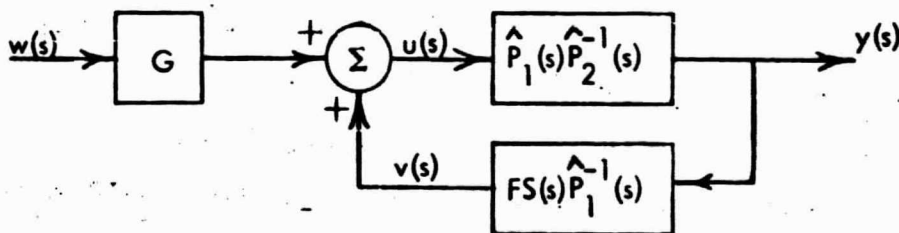

Figure E1

Case 1 Closed Loop System

The overall system represented by Figure E1 is 6-th order with four pole-zero cancellations at $s = -1, -1, -2,$ and -2 .^[11] An algorithm for constructing a time domain realization of $FS(s)\hat{P}_1^{-1}(s)$ can easily be determined using the results presented here (section 4) and in reference [1]. In particular, if

$$\begin{aligned} \dot{z} &= Hz + Jy \\ v &= Kz + Ly \end{aligned} \quad (E11)$$

where

$$H = \begin{bmatrix} -7/3 & 2/3 \\ -2/3 & -2/3 \end{bmatrix}, \quad J = \begin{bmatrix} 0 & -1/3 \\ 1 & 1/3 \end{bmatrix}, \quad K = \begin{bmatrix} 8 & -2 \\ -1 & 5 \end{bmatrix}, \quad L = \begin{bmatrix} 2/3 & 3/3 \\ -20/3 & -11/3 \end{bmatrix},$$

then:

$$K(sI - H)^{-1}J + L = FS(s)\hat{P}_1^{-1}(s) \quad (E12)$$

as given by (E10).

Case 2) Consider the case when $m = p = 1$; i.e. the case of scalar (single input, single output) systems. In this case, our results can be tied to the classical resultant and eliminant matrix of Sylvester.[†] In particular, we will write the open loop transfer function $T(s)$ as:

$$T(s) = \frac{P_1(s)}{P_2(s)} = \frac{P_{10} + P_{11}s + \dots + P_{1,n-1}s^{n-1}}{P_{20} + P_{21}s + \dots + P_{2n}s^n} \quad (53)$$

The eliminant associated with this transfer function (or the pair of polynomials $\{P_1(s), P_2(s)\}$) is the $(2n - 1) \times (2n - 1)$ matrix E defined below; i.e.

$$E = \begin{bmatrix} 0 & \dots & 0 & P_{20} & P_{21} & \dots & \dots & P_{2n} \\ 0 & \dots & P_{20} & P_{21} & \dots & \dots & P_{2n} & 0 \\ \vdots & \ddots & \vdots & \vdots & \vdots & \ddots & \vdots & \vdots \\ P_{20} & P_{21} & \dots & \dots & P_{2n} & 0 & \dots & 0 \\ 0 & \dots & 0 & P_{10} & P_{11} & \dots & P_{1,n-1} & 0 \\ 0 & \dots & P_{10} & P_{11} & \dots & P_{1,n-1} & 0 & 0 \\ \vdots & \ddots & \vdots & \vdots & \vdots & \ddots & \vdots & \vdots \\ P_{10} & P_{11} & \dots & P_{1,n-1} & 0 & \dots & 0 & 0 \end{bmatrix} \left. \begin{array}{l} \text{\textit{(n-1) rows}} \\ \\ \\ \text{\textit{n rows}} \end{array} \right\} \quad (54)$$

[†]A discussion of Sylvester's resultant and eliminant matrix can be found in a number of earlier texts dealing with linear equations; e.g. [12].

Note that the entries of E , the eliminant, are simply the coefficients of the polynomials $P_1(s)$ and $P_2(s)$. Sylvester first defined the eliminant matrix and its determinant, the resultant R , and established the fact that the resultant $R = |E|$ is nonzero if and only if $P_1(s)$ and $P_2(s)$ are relatively prime. The significance of this fact, from the point of view of frequency domain estimation, is most important as we will now show.

In the scalar case, a frequency domain estimator is a triple, $\{ Q_1(s), Q_2(s), Q_3(s) \}$, of polynomials which satisfies the three conditions discussed earlier in this section. In particular, $Q_3(s)$ is a polynomial whose roots are the "poles" of the estimator. It is well known that in the scalar case, complete observability of a system is sufficient to insure that a (time domain) estimator with arbitrary poles of order $n-1$ can be constructed.^{[8][9]} Furthermore, this estimator is characterized by the fact that its state and the system output y "exponentially approach" the state, x , of the open loop system with time. An analogous result holds in the frequency domain. In particular, let $Q_3(s)$ be any arbitrary Hurwitz polynomial of degree $n-1$. Recall that $FS(s)$, the difference between $P_2(s)$ and $P_{2F}(s)$ is a polynomial of degree $\leq n-1$. Therefore, the product $Q_3(s)$ times $FS(s)$, as given by (35), is a polynomial of degree $\leq 2n-2$. This product will be written as:

$$Q_3(s)FS(s) = m_0 + m_1s + \dots \dots + m_{2n-2}s^{2n-2} \quad (55)$$

The right side of (35) must also be a polynomial of degree $\leq 2n-2$, and since $P_1(s)$ and $P_2(s)$ are polynomials of degree $\leq n-1$ and n respectively, it follows that $Q_1(s)$ and $Q_2(s)$ must be of degree no greater than $n-1$ and $n-2$ respectively; i.e.

$$Q_1(s) = q_{10} + q_{11}s + \dots \dots + q_{1,n-1}s^{n-1} \quad (56)$$

and

$$Q_2(s) = q_{20} + q_{21}s + \dots \dots + q_{2,n-2}s^{n-2} \quad (57)$$

Note that this also insures that $Q_3^{-1}(s) [Q_2(s), Q_1(s)]$ is a realizable transfer function. The reader can verify that the right side of (35), namely $Q_1(s)P_1(s) + Q_2(s)P_2(s)$ is given by:

$$\left[q_{2,n-2} \quad q_{2,n-3} \quad \dots \quad q_{20} \quad q_{1,n-1} \quad \dots \quad q_{10} \right] E \begin{bmatrix} 1 \\ s \\ \vdots \\ s^{2n-2} \end{bmatrix} ;$$

$\underbrace{\hspace{10em}}_{q^*}$

$\underbrace{\hspace{10em}}_{s^*}$

i.e.

$$Q_1(s)P_1(s) + Q_2(s)P_2(s) = q^*E s^* \quad (58)$$

$Q_3(s)FS(s)$, as given by (55), can now be written more succinctly as m^*s^* , where $m^* = [m_0, m_1, \dots, m_{2n-2}]$. Using this notation, (35) reduces to;

$$m^*s^* = q^*E s^* \quad (59)$$

Clearly, a solution, q^* , of (59) exists if E is nonsingular, namely

$$q^* = m^*E^{-1} \quad (60)$$

Equation (60) can be employed whenever $P_1(s)$ and $P_2(s)$ are relatively prime.[†]

Remark: Equation (59) has been extended to the multivariable case (for certain classes of systems) by the author.^[13]

The utilization of equations (59) and (60) for feedback design will now be illustrated; i.e.

Example of Case 2:

Consider the open loop system whose transfer function $T(s) = (s+3)/(s^2+s-2)$; i.e. $(s^2 + s - 2)y(s) = (s + 3)u(s)$. Clearly, $P_1(s) = p_{10} + p_{11}s$, where $p_{10} = 3$, and $p_{11} = 1$. Also, $P_2(s) = p_{20} + p_{21}s + p_{22}s^2$, where $p_{20} = -2$, $p_{21} = 1$, and $p_{22} = 1$. Furthermore, in this case, $P_1(s)$ and $P_2(s)$ are relatively prime, as the reader can readily verify; i.e. $P_2(s) = (s - 1)(s + 2)$. The open loop system is thus unstable. Suppose we wish to design a feedback control system which would yield closed loop poles at $s = -1$ and $s = -4$. This would imply that $P_{2F}(s) = 4 + 5s + s^2$; i.e. $FS(s) = -6 - 4s$, and if we arbitrarily choose $Q_3(s) = s + 6$, then $Q_3(s)FS(s) = -36 - 30s - 4s^2$, or $m^* = [-36, -30, -4]$ and $s^* = \begin{bmatrix} 1 \\ s \\ s^2 \end{bmatrix}$, in accordance with (55), (58), and (59). By (54) and (59),

[†]This condition is equivalent to complete controllability and observability of the open loop system (in the time domain).^[14]

$$\underbrace{[-36, -30, -4]}_{m^*} \underbrace{\begin{bmatrix} 1 \\ s \\ s^2 \end{bmatrix}}_{s^*} = \underbrace{[q_{20}, q_{11}, q_{10}]}_{q^*} \underbrace{\begin{bmatrix} -2 & 1 & 1 \\ 0 & 3 & 1 \\ 3 & 1 & 0 \end{bmatrix}}_E \underbrace{\begin{bmatrix} 1 \\ s \\ s^2 \end{bmatrix}}_{s^*}, \quad (E13)$$

and by (60),

$$q^* = m^* E^{-1} = [9/2, -17/2, -9] \quad (E14)$$

Since q^* ($Q_1(s)$ and $Q_2(s)$) has been determined, the closed loop system can be constructed as indicated by Figure 1. For this example, one can readily verify that the transfer function of the closed loop system depicted below is equal to $(s+3)/(s+1)(s+4)$ as desired. The system shown is actually a third order system with a pole-zero cancellation at the pole of the estimator; i.e. at $s = -6$. [8][9]

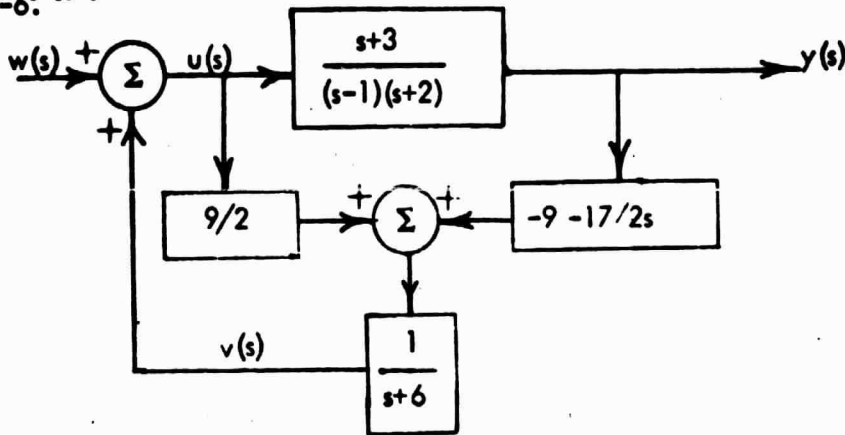

Figure E2

Closed Loop Scalar System

One final point is worth noting before we conclude, namely if in (36), we let $Q_1(s) = 0$ and $Q_3^{-1}(s)Q_2(s) = FS(s)P_2^{-1}(s)$, we would then have

$$u(s) = FS(s)P_2^{-1}(s)u(s) + w(s), \quad (61)$$

or

$$[I - FS(s)P_2^{-1}(s)]u(s) = w(s) \quad (62)$$

from which equations (40) through (43) follow directly; i.e. the control law represented by (61) yields the desired "closed loop" transfer matrix $T_F(s) = P_1(s)$ times $P_{2F}^{-1}(s)$ without any output feedback, since $Q_1(s) = 0$ (see Figure 1). This "input feedback" control law represented by (61) can also be represented by

the relation:
$$u(s) = P_2(s)P_{2F}^{-1}(s)w(s); \quad (63)$$

i.e. from (62), $[P_2(s) - FS(s)]P_2^{-1}(s)u(s) = w(s)$, and since $P_2(s) - FS(s) = P_{2F}(s)$, (63) follows directly. Note that (63) simply represents feedforward compensation. What this simply means is that any "state" feedback control law can be realized by feedforward compensation. Note however, that the control law represented by (61) (or (63)) implies:

i) pole-zero cancellations at the zeros of $|P_2(s)|$, and

ii) an increase in system order equal to n , the order of the given system.

Neither of these two conditions is desirable in most cases for rather obvious reasons; i.e. if $|P_2(s)|$ were not a Hurwitz polynomial, the feedforward compensated system would be unstable. Also, if one employs a feedback design, the increase in system order can always be kept $\leq n-m$.^{[8][9]} There are other reasons for employing feedback rather than feedforward compensation in most cases. A primary reason is sensitivity reduction, a subject which will not be discussed in this paper, but one which is quite important, especially when considered from the point of view of linear optimal control.^[15]

6. Concluding Remarks

We have introduced a new concept and demonstrated its utility in the analysis and design of linear systems. This (frequency domain) concept, namely the notion of representation for proper transfer matrices, was shown to be analogous to the (time domain) concept of realization. An algorithm for obtaining realizations from representations was presented. Frequency domain analogies of other time domain concepts were also given, notably a frequency domain characterization of (simultaneous) state estimation and feedback. For the most part, the results presented relied heavily on some rather elementary definitions and results dealing with polynomial matrices and their manipulation. Areas for future work, tying a closer bond between polynomial matrices and linear system theory, were pointed out at various times. Additional results employing the techniques developed here will also appear soon.^{[13][15]}

Acknowledgement

The author wishes to express his appreciation to P. L. Falb for his many helpful suggestions and criticisms offered during the writing of this paper.

References

- [1] Wolovich, W. A. and Falb, P. L. "On the Structure of Multivariable Systems " SIAM J. Control Vol. 7 No. 3 August, 1969.
- [2] Rosenbrock, H. H. " Relatively Prime Polynomial Matrices " Electronics Letters Vol. 4 No. 11 May, 1968.
- [3] Kalman, R. E. " Mathematical Description of Linear Dynamical Systems " SIAM J. Control, 1 (1963), pp. 152-192.
- [4] Ho, B. L. and Kalman, R. E. " Effective Construction of Linear State-Variable Models from Input/Output Functions " Proc. Third Allerton Conf. 1965, pp. 449-459.
- [5] Mayne, D. Q. " Computational Procedure for Minimal Realization of Transfer Function Matrices " Proc. IEEE, 115 (1968), pp. 1363-1368.
- [6] Rosenbrock, H.H. " Or. Linear System Theory" Proc. IEE, Vol. 114 No. 9 September 1967, pp. 1353-1359.
- [7] Menahem, M. " Notes sur la Theorie des Systemes Multidimensionnels la Factorisation Matricielle " Preprints 1968 IFAC Symposium, Dusseldorf, Ger.
- [8] Luenberger, D. G. " Observers for Multivariable Systems " IEEE Trans. Auto. Control, April, 1966.
- [9] Wolovich, W. A. " On the State Estimation of Observable Systems " Preprints 1968 JACC, The University of Michigan, pp. 210-220.
- [10] Falb, P. L. and Wolovich, W. A. " Decoupling in the Design and Synthesis of Multivariable Control Systems " IEEE Trans. Auto. Cont. AC-12(1967) pp. 651-659.
- [11] Gilbert, E. G. " The Decoupling of Multivariable Systems by State Feedback " SIAM J. Control 7(1969), pp. 50-63.
- [12] Thomas, J. M. Theory of Equations McGraw Hill, 1938, pp. 169-181.
- [13] Wolovich, W. A. " A Generalized Eliminant and Its Application to Frequency Domain Estimation " (to appear).
- [14] Brockett, R. W. " Poles, Zeros, and Feedback: State Space Interpretation " IEEE Trans. Auto. Cont. Vol. AC-10 No. 2 April, 1965, pp. 129-135.
- [15] Wolovich, W. A. and Falb, P. L. " A Frequency Domain Approach to Optimal Control and Filtering " (to appear).