

A SYSTEMS ANALYSIS OF APPLICATIONS OF EARTH ORBITAL SPACE TECHNOLOGY TO SELECTED CASES IN WATER MANAGEMENT AND AGRICULTURE

Volume I - Technical Summary

Reproduced by
**NATIONAL TECHNICAL
INFORMATION SERVICE**
Springfield Va 22151



PLANNING RESEARCH CORPORATION
LOS ANGELES, CALIFORNIA WASHINGTON, D C

FACILITY FORM 400	N71-28444	
	10210	(THRU) G-3
	(PAGES) CR-119010	(CODE) 13
	(NASA CR OR TMX OR AD NUMBER)	(CATEGORY)

A SYSTEMS ANALYSIS OF APPLICATIONS OF
EARTH ORBITAL SPACE TECHNOLOGY
TO SELECTED CASES IN
WATER MANAGEMENT AND AGRICULTURE

Volume I - Technical Summary

PRC R-1224

Revised November 1969

Prepared for

National Aeronautics and Space Administration
Washington, D C

By

Planning Research Corporation

ABSTRACT

A concept for employing multispectral remote sensors onboard spacecraft as a part of an information system to assist in management of specific water resource and agricultural activities is proposed and evaluated. The Technology required is either available or expected to be available by the mid 1970's. The system concept relates all components and subsystems to decisions and actions which concern the managers and users of the information which could be provided, even though the system has not been optimized with respect to equipment and configuration. The specific applications studied were (1) water management of the Columbia River Basin to increase benefits from hydropower generation, irrigation, flood control, navigation, and recreation, (2) management of wheat crop yield and inventory control for the United States, considering worldwide wheat demand and production, and (3) early detection and control of wheat rust fungi to increase the wheat yield in the United States. The benefits estimated for the Pacific Northwest were extrapolated separately to major river basins in the rest of the United States considering individual basin characteristics, and estimated for the rest of the world using broader assumptions. The potential benefits from wheat crop yield and inventory management were estimated for the United States considering worldwide production and then extrapolated to potential world benefits. Similarly, wheat rust control benefits were estimated for U S farmers and extrapolated to the rest of the world. The benefits to the three earth applications studied were made possible by a single system of multispectral remote sensors, spacecraft and data transmission and processing. The system concept includes four satellites, each carrying three remote sensors along with appropriate equipment for attitude control, data storage, and telemetry. A multispectral scanner, a multispectral television, and a multiband radar are used for remote sensing of earth phenomena. The ground components comprise five data receiving (and command and control) sites that will forward data to a centralized location for processing and information analysis. The information, in a form directly usable by earth resource managers, can be delivered on existing user agency networks. The estimated total incremental cost of this conceptualized system was compared with the estimated potential benefits from each application. Benefits and costs of the space assisted information system were compared to benefits and costs of an aircraft assisted information system as well as of selected non-information alternatives. The potential benefits from the space-assisted information system were estimated to be substantially greater than the expected costs. The study scope did not include evaluation of all possible alternative means of realizing benefits, thus, conclusions should not be drawn solely from this study as to favored courses of action for user agencies.

FOREWORD

This study has been completed in partial fulfillment of a request by the Bureau of the Budget to the National Aeronautics and Space Administration (NASA) for a systems analysis of several specific applications of satellite-based remote sensing to earth bound problems. The study was funded and managed by the NASA Office of Space Science and Applications (OSSA) and was coordinated and reviewed by the interagency Earth Resources Survey Program Review Committee (ERSPRC). The committee is chaired by a NASA representative and currently includes representatives from US Departments of Agriculture, Interior, Commerce, and Navy. The prime contractor, Planning Research Corporation (PRC) was assisted by the Willow Run Laboratories of the University of Michigan under a subcontract to supply technical data and judgments on sensor capabilities.

The focus of the study was formulation and evaluation of feasible future operational system concepts for applying satellite based remote sensing to improve the management of specific water resource and agricultural activities. These future operational concepts were assumed to follow the present research and development time frame of the NASA-user agency Earth Resources Survey Program. It was recognized at the outset that considerable research and development would be required before any such future operational concepts could be realized. It was, however, the principal purpose of the study to assess the position that future operational space assisted ERS systems concepts were of sufficient promise to warrant rapid development of experimental Earth Observations satellites known as Earth Resources Technology Satellites (ERTS).

The scope of the present study required emphasis on concepts for using space technology rather than on improvements not requiring assistance from space. However, it was clear that any satellite assisted information system concept should be compared with improvements not using satellites. In addition, it was

expected that any system using satellites would support and complement many of the existing or planned user agency systems and procedures. Thus, while specific alternatives to satellite-assisted information systems were evaluated, the scope of this study did not permit evaluation of integration with all user agency systems or of all alternative programs available to the user agencies. This study does present a concept for a satellite assisted information system, an estimate of the expected costs along with the expected benefits, and a comparison with some selected alternatives.

As prime contractor, PRC wishes to express its appreciation to the organizations associated with ERSPRC for assistance through ready access to knowledgeable personnel who provided data and guidance vital to the success of the study. In the final phase of the work, ERSPRC (and its Benefits Studies Subcommittee) participated in a detailed review and criticism of the complete final report. This review, however, does not imply endorsement of the system configuration details or cost-benefit dollar values.

The NASA Project Officers were Mr J Robert Porter and Dr Robert A Summers. The PRC Project Managers were Dr Allan H Muir and Mr John F Magnotti, Jr.

The final report on this study is presented in two volumes. The full description of the work is contained in Volume II, Technical Report, and is supported by nine appendixes and a bibliography. The appendixes are the following:

- Appendix A — User Sensor Model—Hydrology
- Appendix B — Hydrological Models
- Appendix C — System Operation and Benefits
- Appendix D — Satellite System Description and Costs
- Appendix E — Alternative Information Systems
- Appendix F — Non information Alternatives

PRECEDING PAGE BLANK NOT FILMED

Appendix G -- User Sensor Model--Agriculture

Appendix H -- Wheat Production Management

Appendix I -- Wheat Rust Control

Volume I, Technical Summary, is a much briefer description of the significant aspects of the work. Detailed descriptions of the calculations and procedures referred to in Volume I will be found in Volume II.

The analysis, findings, and conclusions expressed in this report are those of PRC and do not necessarily reflect the views of the ERSRPC or its member agencies.

TABLE OF CONTENTS

		Page
I	INTRODUCTION	1
	A Purpose and Objectives	1
	B Background	1
	C Scope	2
	D Major Limitations and Assumptions	2
	1 Point Design	2
	2 Cost Allocation to Users	2
	E Study Plan	3
	1 User Decision Process	3
	2 Sensors	4
	3 Data Transmission and Use	4
	4 User Participation	5
	5 Research and Development	5
	6 Costs and Benefits	6
II	CONCEPTUAL INFORMATION SYSTEM	7
	A Existing Information Networks	7
	1 Water Management	7
	2 Agriculture	9
	B Information and Data Requirements	12
	1 Pacific Northwest Water Management	12
	2 Wheat Crop Management	13
	3 Wheat Rust Control	13
	C General Configuration for a Satellite-Assisted Information System	13
	1 The Space Segment	15
	2 Remote Sensors	15
	3 Ground Receiving Stations	19
	4 Ground Lines	19
	5 Interpretation and Analysis Center	20
	6 Information Users	22
III	MODEL DESCRIPTIONS	23
	A Water Management	23
	1 Selection of the Columbia River Basin	23
	2 The Water Management Problem	24
	3 Forecasting Models	25
	4 System Integration	26
	5 Scenario Analysis	30
	6 Detection and Verification	31
	7 Dynamic Sampling Technique	31
	B Wheat Crop Management	31
	1 Background	31
	2 The Management Problem	32

TABLE OF CONTENTS
(Continued)

	3	User Models	32
	4	System Integration	34
C		Wheat Rust Control	36
	1	Background	36
	2	Wheat Rust Control Problem	37
	3	User Models	37
	4	System Integration	37
IV		BENEFIT-COST ANALYSIS	39
	A	System Costs	39
	B	Water Management Benefits	39
		1 Benefits in the Pacific Northwest	39
		2 Extrapolation to the United States and the World	41
		3 Sensitivity Analysis	41
	C	Wheat Crop Management Benefits	43
	D	Wheat Rust Control Benefits	43
	E	Benefit Cost Analysis	45
V		ALTERNATIVES	47
	A	Noninformation Alternatives	47
		1 Water Management	47
		2 Wheat Crop Management	47
		3 Wheat Rust Control	48
	B	Information Alternatives	48
		1 Water Management	48
		2 Wheat Crop Management and Wheat Rust Control	48
VI		CONCLUSIONS	51

LIST OF EXHIBITS

	Page
1 Model of Study Concept	3
2 Study Plan	4
3 Columbia River Basin Information and Decision System	8
4 Wheat Information Flow Chart	10
5 General System Configuration	14
6 Orbital Patterns Four Satellites	16
7 Probabilities of Coverage for Three Case Studies (55° Orbit Inclination Angle, 360 n mi Swath Width, 500-n mi Altitude)	16
8 Major Hydrologic Parameters and Sensor Capabilities	17
9 Multispectral Scanner Design and Performance Characteristics	18
10 Television Systems	18
11 Interpretation and Analysis Center Data Processing Concept	21
12 Columbia River Power System	23
13 Simplified Water Management Model	25
14 Contribution of Potential Remote Sensor Data to Water Management	26
15 Runoff Hydrograph After Impulse	26
16 Expected 1975-80 Columbia River Basin Configuration of Dams and Power Generation Capacity	27
17 Format of Relevance Matrices	28
18 Sequential Matrices Relating Sensors to Water Management	29
19 Seasonal Variation in Snowpack	30
20 Regions of Principal World Wheat Production	33
21 Regions of Principal World Corn, Sorghum, Millet, and Rice Production	33

LIST OF EXHIBITS
(Continued)

22	Sequential Matrices Relating Sensors to Wheat Management	35
23	Wheat Acreage in the United States With Patterns of Possible Rust Infection	36
24	Sequential Matrices Relating Sensors to Wheat Rust Control	38
25	Annual Total System Costs 1970-90 in Billions of 1968 Dollars	39
26	Annual Total System Costs 1970-90 Discounted to Present Value (1970 Dollars)	40
27	Annual Pacific Northwest Power Benefits 1973-90 Discounted to Present Value at 10 Percent (1970 Dollars)	40
28	Annual Pacific Northwest Water Management Benefits 1973-90 Discounted to Present Value at 10 Percent (1970 Dollars)	41
29	Annual U S and World Water Management Benefits 1973-90 Discounted to Present Value at 10 Percent (1970 Dollars)	42
30	U S and World Annual Water Management Benefits 1973-90 Discounted to Present Value at 7½, 10, and 12½ Percent (1970 Dollars)	42
31	Annual U S Wheat Management Benefits 1973-90 Discounted to Present Value at 10 Percent (1970 Dollars)	43
32	Annual World Wheat Management Benefits Excluding U S 1970-90 Discounted to Present Value at 10 Percent (1970 Dollars)	44
33	Annual U S Fungi Control Benefits 1973-90 Discounted to Present Value at 10 Percent (1970 Dollars)	44
34	Annual World Fungi Control Benefits Excluding U S 1973-90 Discounted to Present Value at 10 Percent (1970 Dollars)	44
35	Annual U S and World Water Management Costs and Benefits 1970-90 Discounted to Present Value at 10 Percent (1970 Dollars)	45
36	Satellite-Assisted Information System Total Costs and Benefits 1970-90 Discounted at 10 Percent	46
37	Costs of Multi Purpose Satellite and Aircraft Information Systems for Water Management	49
38	Costs of Satellite and Aircraft Information Systems	50

I INTRODUCTION

I INTRODUCTION

A PURPOSE AND OBJECTIVES

The purpose of the present study has been to provide analytical support to advance the joint NASA user agency efforts in exploring the feasibility and practicality of using space systems for meeting existing and projected needs on Earth. A significant aspect of the study was the examination of economic tradeoffs between space systems and aircraft systems for potential assistance in providing better information for improvements in management of water resources and agriculture. In addition, improvements stemming from better information were compared with non-information improvements (e.g., the benefits and costs of the use of improved information for water management versus improvements from construction of new dams). The scope of the study did not permit comparison of these alternatives with present and projected non-space, non-aircraft information systems operated by the user agencies themselves, thus, benefits identified are not incremental to those alternatives but represent estimated total benefits. No conclusion should be drawn solely from this study as to favored courses of action for user agencies, but at the same time, the results of this study provide guidelines for indicating the direction and priority of existing and planned NASA research and development activities in the field of space applications.

This study constitutes an analysis of a possible future operational concept for a satellite-assisted information system. Its objectives are

- To identify management and participant information requirements in water management, wheat production and wheat rust prevention
- To conceptualize a satellite supported information system capable of supplying appropriate effective information
- To estimate total system benefits and costs, including research and development costs

- To examine alternative cost and benefit relationships to provide guidance for the formulation of resource allocation policy decisions

B BACKGROUND

This study is the second in a series that has identified potential users of data produced by remote sensors and investigated potential benefits from specific future operational satellite applications for the management of earth resources. In the first study,¹ a basic framework for benefit/cost analysis was developed for earth oriented space missions. The procedure was exercised in five case studies, and the potential 1970-89 pecuniary and nonpecuniary benefits of earth oriented satellite-assisted information systems were estimated. This second study is a logical extension of the first, but the emphasis has been shifted from individual case studies *per se* to the development of a complete concept of a multi-purpose satellite assisted information system designed to improve water management, wheat production and wheat rust control.

The material presented in the Technical Summary has been organized to emphasize the conceptual system design. Section II describes the concepts and characteristics of the proposed system. Section III describes the models and scenarios used to relate sensor data to user application. Section IV deals with estimated system costs and with potential benefits from each of the activities studied—water management, wheat production, and wheat rust control. Section V discusses two kinds of alternatives to a satellite assisted information system—aircraft assisted information systems and improvements, such as construction of additional dams, that do not make use of improved information. Finally, Section VI is a brief

¹Planning Research Corporation PRC R-1218 *A Study of the Benefits and Implications of Space Station Operations*, January 1968

statement of principal conclusions that have been drawn from the study

C SCOPE

Since any contemplated operational satellite assisted information system is both complex and extensive, it was initially clear that specific limiting assumptions and ground rules would be needed to keep the study effort within reasonable bounds. The system includes space vehicles with remote sensors, ground stations for receiving and processing data from both satellites and ground observations, and distribution of user information to water managers and farmers, as well as a need for system management and organizational interfaces. It was recognized that a satellite assisted information system would operate in conjunction with other existing and planned systems, not independent of or instead of them. For example, use of precipitation radar on board a satellite does not necessarily imply reduction in the need for an expanded comprehensive ground weather radar system. In fact, it is realistic to expect that a future operational system would make use of data from satellite sensors, from aircraft sensors, from ground based observation stations and from historical files. Finally, it was anticipated that an operational system would involve the governmental community of user agencies as well as the private sector.

The complexity of the system and interactions posed above led to a decision to limit the analysis to postulating a conceptual system for providing information directly useful in river basin management and in agriculture. The conceptual system presented in this report is feasible in the sense that technology and management practices are available to make the system operational in the mid-1970's. The study scope was not intended and did not permit the design of an optimized system that could account for all possible technical and economic tradeoffs. Rather, this study should be considered as an initial effort to bring together all of the relevant components of an operational system concept to accomplish the specific missions selected. Although the conceptual system presented in this report does interface with some user agency systems, the scope of this study did not allow full analysis of integration with ground-based observation subsystems, with potential aircraft subsystems, or with other components and procedures of government user agencies and the private sector. The costs and benefits estimated in this study, therefore, reflect

only the conceptual system presented in this report with the limitations and assumptions as stated throughout the discussion. The major limitations, assumptions and ground rules that bounded the study are given below.

D MAJOR LIMITATIONS AND ASSUMPTIONS

1 Point Design

In developing a concept for a satellite assisted information system, a point design approach was used. That is, the missions (water management and agriculture) were selected and information requirements derived from analysis of the decisions or actions taken by actual users. The space segment was selected by judgment and limited analysis of feasible components available to support the information requirements. The basis for the conceptual design was determined by study of selected geographical regions and potential information improvements as presented in subsection I E, Study Plan. Further analyses at greater levels of detail would be required to reach an optimum design concept. In this regard, the sensor package recommended for the satellites should not be construed as definitive design. The fact that the selected sensors satisfy specific information requirements should not inhibit continued research to improve performance characteristics or research of other sensors, such as the passive microwave radiometer, the laser altimeter, and other promising instrumentation.

2 Cost Allocation to Users

In this study, the users were farmers concerned with wheat production control and wheat rust, and managers of river basins and dams concerned with hydropower production, flood control, and navigation. Since the space segment of the conceptual system was designed to support the information needs of all these users, no attempt was made to allocate portions of the cost against individual users or groups of users. The study showed that the satellite and ground support configuration designed for water management was adequate to support improved wheat production and wheat rust-control management. In addition, the water management benefits for the United States were sufficient to support the cost of the entire satellite-assisted information system.

E STUDY PLAN

The entire study followed the concept shown in Exhibit 1. Specific conditions on the Earth are observed by remote sensors onboard satellites. Data from the sensors are transmitted to the ground for analysis and interpretation, along with data from meteorological and other complementary or supporting (e.g., ground truth) systems. The processed data are used in earth resources models to provide information and forecasts for users (earth resources managers). Application of information and forecasts in user decision models will result in resource management actions. These actions along with changing natural phenomena will provide a new set of earth conditions for subsequent observation by the satellite remote sensors. Thus, the process is a continuing one as indicated by the arrows in the exhibit.

The general concept discussed above was used to develop the study plan shown as a flow diagram in Exhibit 2. Although each task is not discussed in detail in this subsection, it is important to note significant assumptions and procedures.

1 User Decision Process

The dominant orientation of the study was toward the information needs of the user or manager. The decision requirements of these users and managers form the logical starting point for developing the information system and supporting data requirements. In this way system designers can be assured that the resulting system concept will be responsive to its basic purpose. The specific user/manager cases selected as a basis for developing the satellite assisted information system were:

- Water management in the Pacific Northwest
- Wheat crop management in the United States
- Wheat rust prevention in the United States

In each case the satellite assisted information system was compared with an aircraft system.

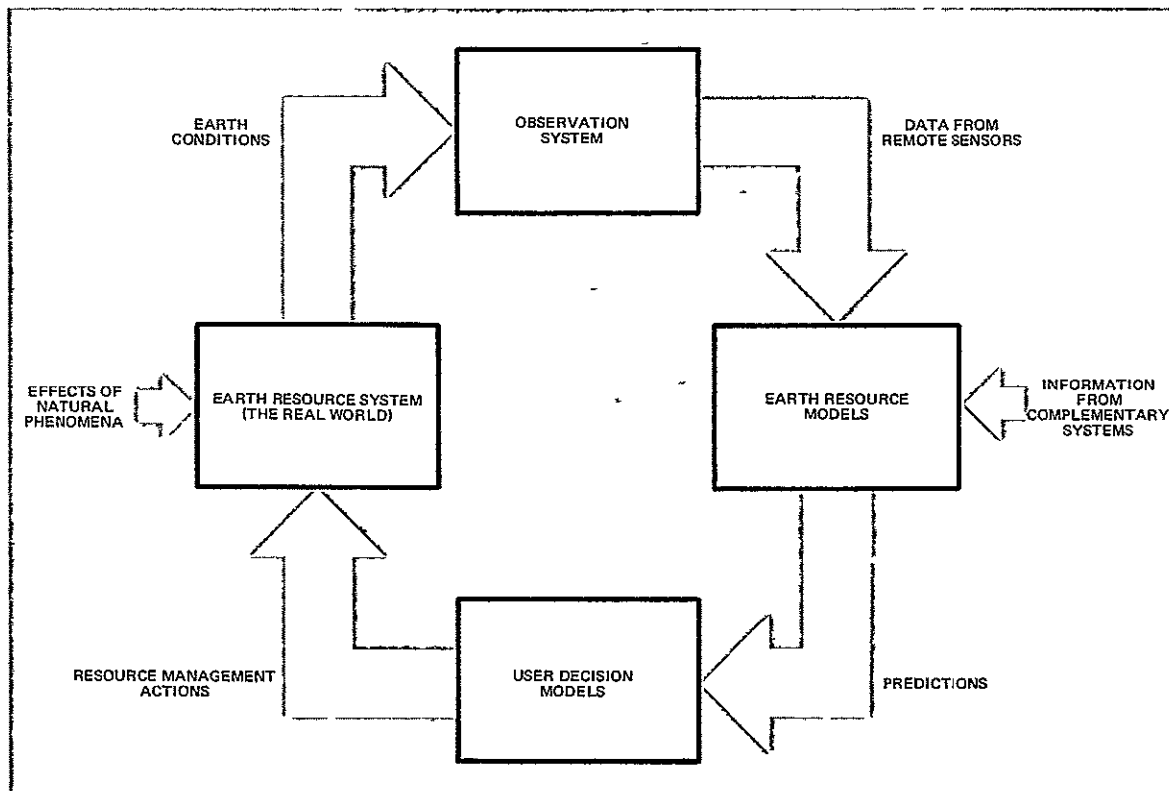

Exhibit 1 Model of Study Concept

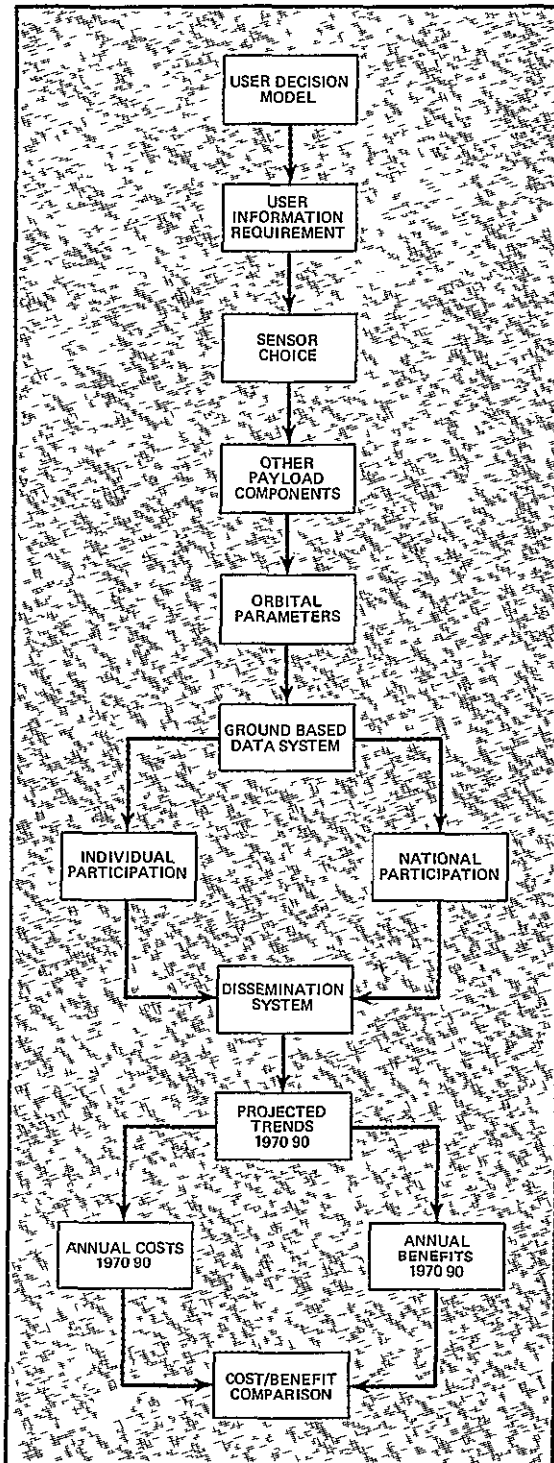

Exhibit 2 Study Plan

that provided similar information. Since benefits can be achieved by means other than improved information to users or managers, the satellite-assisted information system benefits were also compared to the following non information alternatives:

- Dam construction and nuclear power plants
- A wheat storage program
- Research on rust resistant wheat varieties

2 Sensors

Basic engineering studies for the satellite's sensor package were made by the Willow Run Laboratories (WRL) at the University of Michigan, Ann Arbor. In all cases, the sensors selected for the conceptual system are either operational or judged feasible for early development. Since a primary consideration in the choice of sensors for the conceptual system was early availability, it is expected that current or planned research will produce more capable or more efficient sensors. It was considered practical and credible in this study to select sensors having documented performance characteristics so that data flow specifications could be readily determined.

Projected sensor capabilities were extrapolated from laboratory data to satellite altitudes by means of a computerized model. During the experimental phase conducted by the Willow Run Laboratories, the extrapolation model was used to predict sensor capabilities first at aircraft altitudes. These predictions were then verified during test flights in the Midwest. Close correlation between model extrapolation and actual aircraft test results indicated that sensor capabilities at satellite altitudes could be predicted with reasonable accuracy. In addition to remote sensors, other hardware components selected for the conceptualized space segment either exist or are in the final stages of development.

3 Data Transmission and Use

Early in the study it was apparent that the quantity of data that could be acquired by continuous operation of the remote sensors could seriously overload the anticipated capabilities of the transmission and analysis subsystems. In addition, the power

required for continuous operation of satellite borne radar would be prohibitive as well as unnecessary. It appears, however, that dynamic sampling¹ can be used to acquire sufficient data to ensure an adequate basis for meeting user information needs. With dynamic sampling, repetitive total mapping procedures will not be necessary, rather, discernible patterns of change in meteorological, hydrological, and agricultural phenomena need merely be monitored. Interpretation and analysis during the initial operational phase will be primarily manual, however, it is anticipated that software will be developed to provide a substantially automated system.

The conceptual system includes a central interpretation and analysis facility from which information will be disseminated to users through existing information networks used by the various agencies. For example, it would be difficult, expensive, and unnecessary to attempt at this time to design a system for reaching individual farmers through communications networks better than those now used by the agricultural extension service.

4 User Participation

Realization of actual benefits from an information system depends directly on the extent of participation of those users who make decisions or take action to manage specific river basins, to make wheat acreage allotments, to decide the level at which Commodity Credit Corporation (CCC) wheat stocks should be maintained, or to order particular wheat fields to be sprayed with fungicide. In water management, the users are the dam managers as well as the agencies or groups who determine policy and decision rules for control of a river basin. The water management users thus comprise a rather small identifiable group motivated to participate in using improved information. However, for those river basins where multi purpose management (e.g., hydropower generation, flood control, navigation, irrigation) is necessary, a number of user groups must usually coordinate their various and often conflicting interests to arrive at decisions upon which action is taken. In spite of such difficulties, participation in the use of improved information by river basin managers is expected to be high.

¹See subsection III 7

In agriculture, the user is the farmer and although participation by farmers in agricultural programs has at times been relatively low, it appears now that there is a trend toward greater participation. This is especially true where benefits to farm operators can be more clearly identified and quantified. Farmer participation is being further reinforced by the tendency toward larger and more profit-conscious farm operations. Because of such current trends, benefits calculations recognize increasing farmer participation as the system evolves and its rewards become apparent. Global participation in the wheat yield case is uncertain, since numerous unpredictable factors beyond those directly related to management are involved in any systems requiring joint participation by several individual sovereign powers.

The maximum potential rate of farmer participation was assumed to be 90 percent in both wheat cases. Benefits were adjusted to reflect the capability of the satellite system and the participation rates of government agencies and farmers. These rates were averaged and applied to the maximum annual benefit to derive a more realistic estimate of increasing annual benefits over the 1971-90 period. Because of changes in the capability of the satellite system and the ability of farmers to adjust their enterprises when provided with improved information, benefits do not occur at the same rate throughout the 20 year period. Participation rates, therefore, begin at 10 percent in the early stages of the analysis and rise gradually to the maximum of 90 percent.

Farmer participation rates are based upon discussions with researchers engaged in diffusion research. These include George Beale, University of Iowa, Marion Brown and Len Maurer, University of Wisconsin, and Milton Morris, University of Minnesota.

5 Research and Development

Research and development costs were included in the study and in the benefit cost analysis, since it is clear that continued vigorous effort of this kind is a prerequisite to an operational system. For example, the initial Earth Resources Technological Satellite (ERTS) to be launched in 1972 will undoubtedly contribute significantly to knowledge needed to pursue the earth resources program. The ERTS experimental effort as well as other research and development activities are essential, and their

contributions should be recognized. In fact, some of the major findings in this study deal with the future direction of research and development in areas other than the space components of the system. This is evident, for example, in hydrology, where there is a critical requirement to develop earth science models, and also in agriculture, where there is a clear need to continue research in plant pathology and its susceptibility to management through timely remote sensing of significant phenomena.

6 Costs and Benefits

The method used for calculating costs of the conceptual system developed in this study was to estimate a dollar value (in 1970 dollars) for each year from 1970 to 1990. This stream of estimated total system costs was then discounted to present value. Benefits were separately estimated for each of the three cases selected for study. In order to compare benefits with total system costs, the benefit streams were also discounted to present value.

Since costs incurred prior to a decision to build and operate the system must be considered as sunk costs, it is necessary to fix a decision year to begin the cost stream and a schedule for implementation. To provide a basis for the study, 1970 was selected as the decision year with an implementation schedule such that benefits could begin in 1973. Although it was recognized that the earth resources program, as it evolves, will follow a schedule different from that assumed, a modified schedule should not detract significantly from the usefulness of this study as a planning document. Cost and benefit streams can be adjusted as necessary to adapt to changes in schedules. All costs and benefits were discounted to 1970 dollars at 7½, 10 and 12½ percent discount rates¹ to identify sensitivity and to permit planners latitude in comparing implications of different courses of action.

¹See also BOB Circular A-94, June 26, 1969 which specifies guidelines for selection for discount rates in systems analysis.

II CONCEPTUAL INFORMATION SYSTEM

II CONCEPTUAL INFORMATION SYSTEM

The basic study objectives previously stated (page 1) are not independent, but form a logical and interrelated sequence for proceeding through the study. User information requirements determine the nature of the remotely sensed data needed. A further definition of requirements in terms of quality and timeliness of data is needed to determine a system configuration. Finally the information provided by the conceptual system can be used to estimate benefits, while the selected system configuration is the basis for estimating costs. The starting point is user information requirements. This section discusses user information requirements, data requirements, and the conceptual system configuration.

A EXISTING INFORMATION NETWORKS

1 Water Management

The basic problem in water management is to forecast water flow volumes accurately. The flows are often highly variable and may cause abrupt and unanticipated changes in hydroelectric power generation, irrigation, flood control, navigation, and recreation. This study addresses one such water management case, namely, the Columbia River Basin, including the tributaries that drain the northwestern portion of the United States. In this basin, water management must consider multiple purposes and is performed by multiple agencies, including the Bonneville Power Administration (BPA), the United States Army Corps of Engineers (CE), the Bureau of Reclamation, and other public and private groups. The Columbia River Basin is particularly significant because it illustrates how the interests of various users of water may differ and often conflict.

Exhibit 3 is a schematic representation of the current flow of information related to management of the Columbia River Basin. In general, water management in the basin is performed by three main groups: the BPA, non-Federal power producers, and the CE. Although the Bureau of Reclamation, Depart-

ment of the Interior, has constructed several of the larger dams, primarily for irrigation purposes, control has been delegated to BPA with the understanding that a specified quantity of water be allocated annually for irrigation. The non-Federal producers, on the other hand, are interested almost entirely in water management for power generation and marketing while the CE is responsible for all flood control measures within the river system.

The control of the river basin's water is coordinated through the Pacific Northwest Coordination Agreement, which has been signed by Federal, state, and local organizations, public and private, who are concerned directly with power production and water management. The Coordination Contract Committee, a group formed from member representatives, coordinates actual operations in accordance with the terms of the agreement. The most important job of the Committee is to prepare the operating program that sets the reservoir rule curves and energy requirements for each year. The Committee also is responsible for readjusting variable energy content curves from January through July.

In addition to the Coordination Contract Committee, coordination of water management is of interest to the Columbia River Water Management Group, the Northwest Power Pool, and the recently created Columbia River Basins Commission. The Columbia River Water Management Group acts only in a coordination and advisory role and includes representatives not only of agencies actually involved in water management but also of other agencies interested in and affected by water management. These include the Bureau of Reclamation, the Federal Power Commission, the Public Health Service, and the Department of Commerce. The Northwest Power Pool is currently an informal coordinating group of power producers although prior to the Pacific Northwest Coordination Agreement it was the primary agency for coordination of water management and power production in the Northwest. The Columbia River Basins Commis-

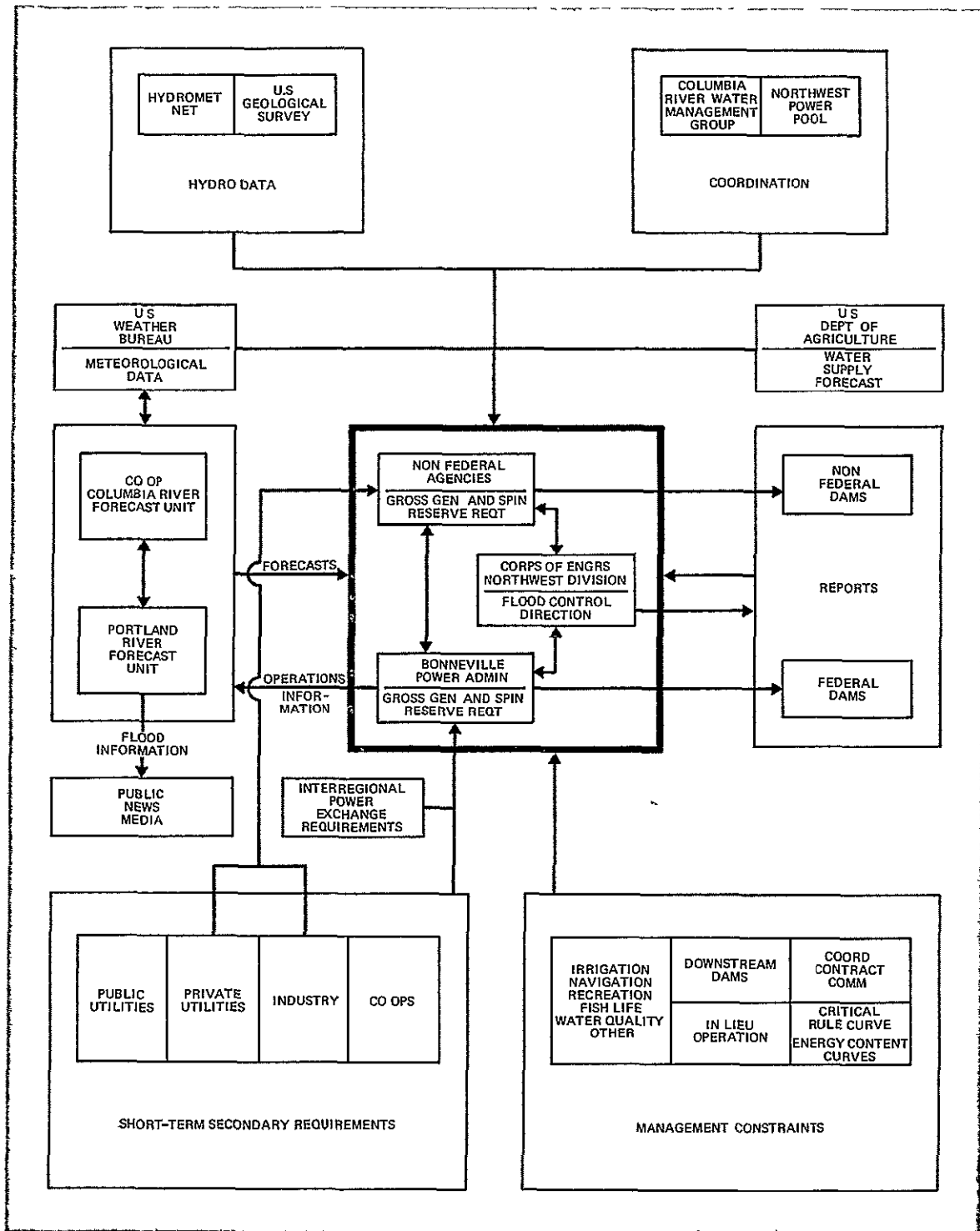

Exhibit 3 Columbia River Basin Information and Decision Network

sion, a relative newcomer, deals mainly with studies concerning the Columbia River Basin and is funded jointly by the Federal Government and five north-western states

The private industrial establishments concerned with power production are primarily the aluminum producers in the area. Led by Alcoa, Kaiser, and Reynolds, these companies account for the bulk of industrial power requirements in the Northwest

The current information system is characterized by a multiplicity of data sources and forecasting procedures. Water runoff forecasting, a requirement for all power producers, ranges from very informal daily estimates to formal long range forecasts (based on Weather Bureau and other data) prepared either by the power producers themselves or by private agencies that purchase power on contract. Although there is an exchange of hydrological and meteorological data among the interested parties, variations in the actual forecasting procedures produce wide variances in individual water-availability forecasts. Only a modest amount of automation exists to support forecasting, mostly in the form of computerized models used by the BPA and the CE. These models also use Weather Bureau data as input.

The normal operational direction and monitoring of Federal dams for power production originates in BPA. During the flood season, the CE assumes primary management of the Columbia Basin and issues flood control direction. The non-Federal power producers operate their dams in coordination with BPA and CE with the stipulation that flood control directions have priority during the flooding season.

In recognition of the need to discuss individual interests with the users, a series of information user surveys was conducted. These surveys were designed to include a reasonably broad spectrum of government and non government groups who would be potential users of the satellite-assisted information system. Because the system would be applicable to other areas of the United States, discussions were also conducted with various interested agencies in California and the Northeast. The survey clearly identified a solid consensus among users that better information could make a substantial contribution to more effective water management.

2 Agriculture

Two aspects of agricultural management were investigated, wheat inventory/yield and wheat rust. Since there is a close interrelationship between the two, the discussion of the information systems has been combined.

As shown in Exhibit 4, the United States Department of Agriculture (USDA) is the organization most involved in all aspects of wheat management. Data collection and crop projection are handled primarily by USDA's Statistical Reporting Service (SRS), Economic Research Service (ERS), and Foreign Agricultural Service (FAS). Both wheat yield and stress (e.g., wheat rust) are monitored by USDA. Other groups involved include agencies of foreign governments, universities and colleges, commercial wheat enterprises, and wheat producers. USDA, however, is at the center of the system and must be considered the primary decision point for agricultural monitoring, analysis, planning, and direction in the United States.

Global wheat information currently is collected and disseminated by three systems: international organizations, federal governments, and private grain interests.

The United Nation's Food and Agricultural Organization (FAO) and the International Wheat Council (IWC) collect historical data and forecast world production. Most of the data are supplied by member countries or by the cooperation of non members. Analytical results are distributed to member nations and are made available to any interested party through a number of official publications.

The FAO generates a short-term market prospect analyzed on the basis of current or expected yield, known demand, and existing trade agreements. Long-term projections assume a certain political and economic environment in calculating the 10-year outlook. A program is presently being established by FAO to generate a medium term projection combining the elements of short-term supply and demand and long range policy.

For the past 10 years the IWC has projected supplies and closing stocks in eight exporting

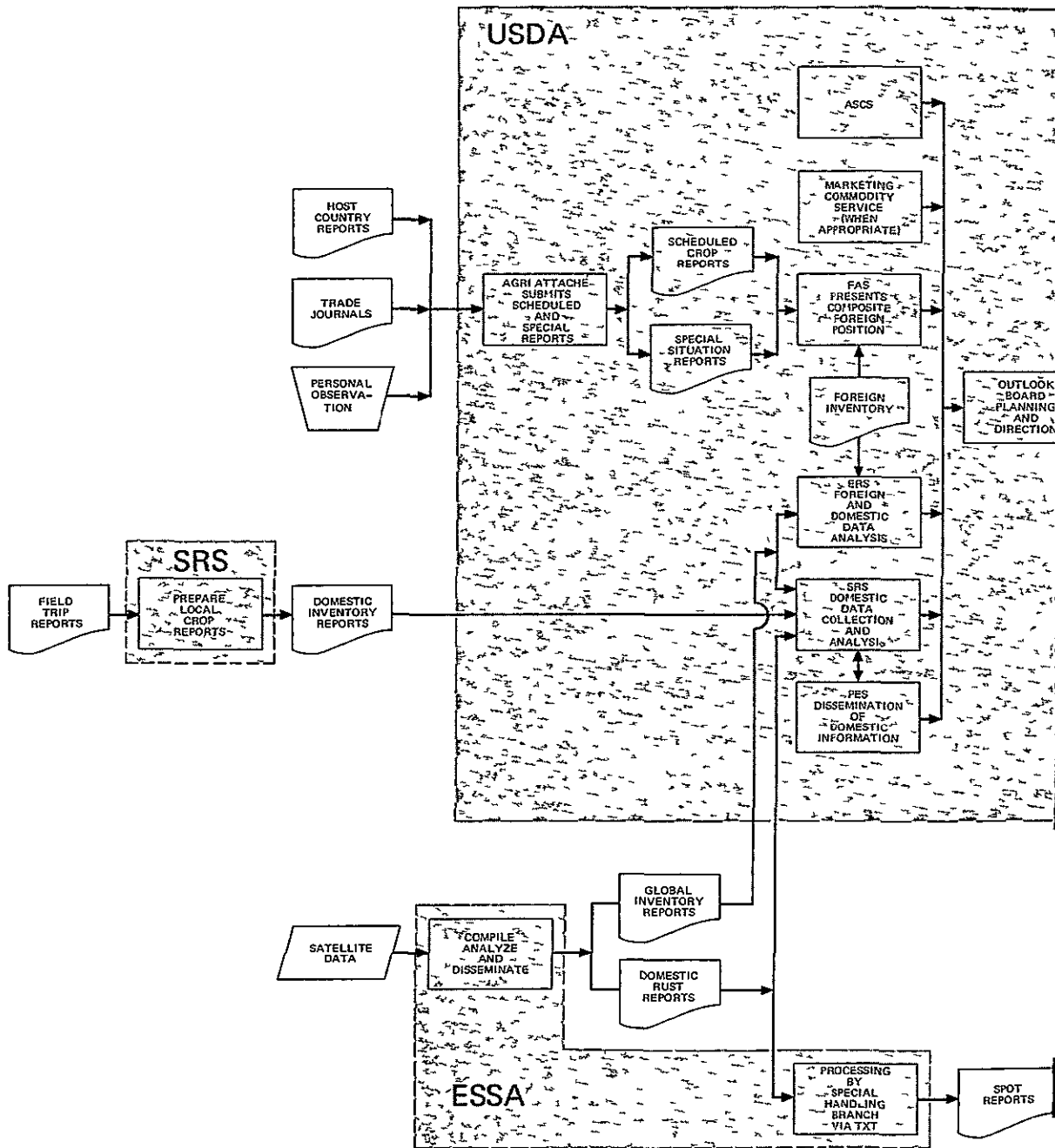

FOLDOUT FRAME

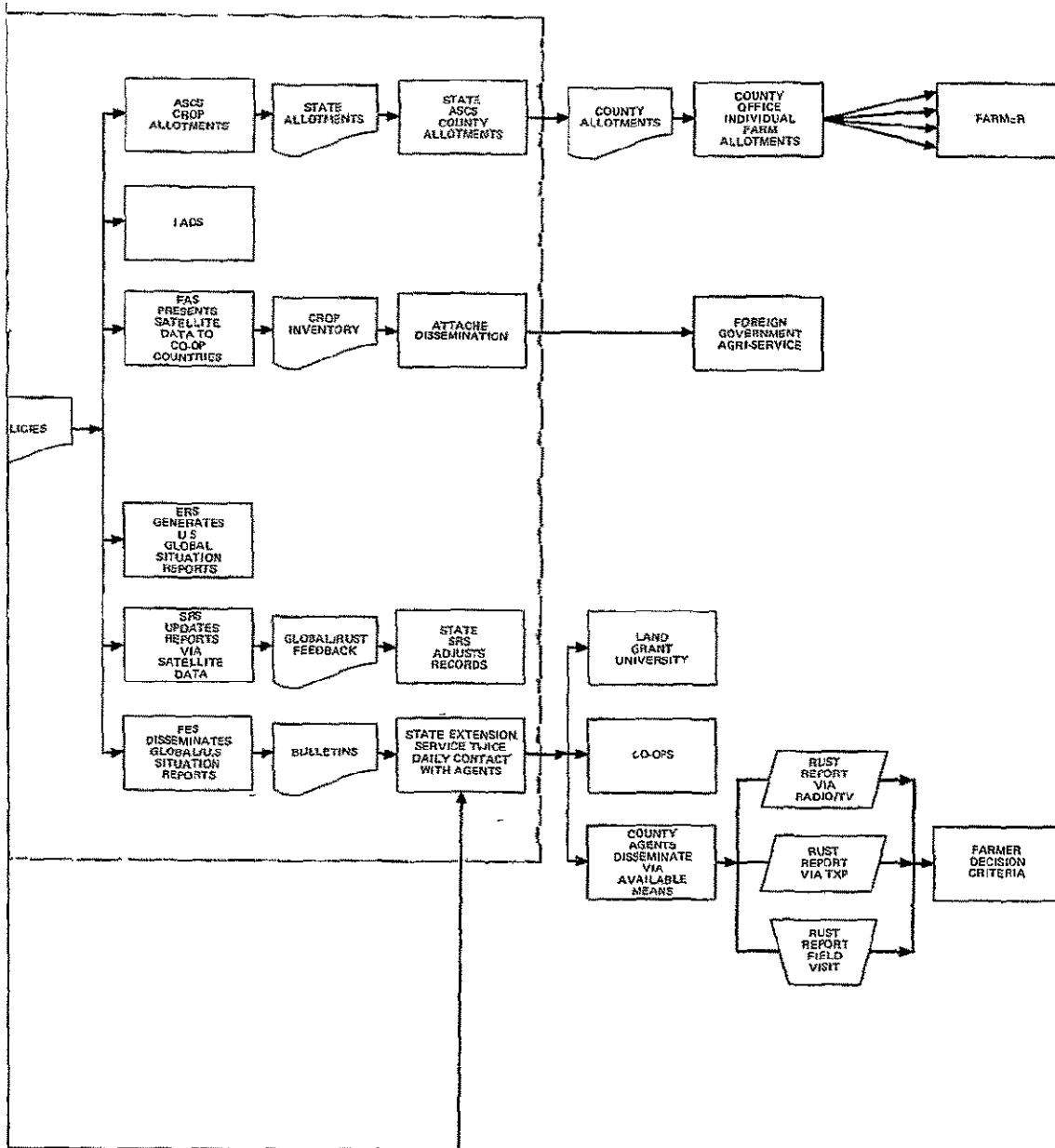

Exhibit 4 Wheat Information Flow Chart

countries and has projected production and imports by regions of the world. However, its annual review is of limited usefulness for projections in marketing and production planning since it is released in late fall.

The United States, through USDA, prepares quarterly wheat situation reports and an annual outlook projection for wheat. Global information is submitted through Foreign Agricultural Service 'attache' reports four times yearly and through special reports of intervening events. 'Host country' information is obtained through personal observation, foreign government statistics, news releases, trade journals, and marketing representatives. U.S. domestic information is collected by state statistical reporting services. Analysis of the domestic and world wheat situation by ERS provides the basis for the global outlook projection and the annual U.S. wheat acre allotment.

Grain exporters in the United States have extensive data collection information systems within their individual companies. Although reports are market oriented, grain companies review world production projections extensively. The exporters collect information through the same sources available to the FAS and also through their own contacts with host country grain interests. Reports issued by grain exporters do not conform to any schedule, but generally precede USDA outlook reports that are used by exporters to supplement commercial grain projections.

Domestic wheat rust statistics are published by USDA in conjunction with the University of Minnesota at the Cooperative Rust Laboratory in the April-June issue of the *Plant Disease Reporter*. State agricultural universities and university-sponsored research laboratories are used for data collection and program support. An industry sponsored group, the Crop Quality Council, composed of scientists and agricultural experts, also collects and publishes domestic rust information. On the local level, the State Extension Services (SES), with the cooperation of county agents and universities, propagate qualitative rust information, but with emphasis on proper variety planting rather than on location of expected rust appearances or on reporting of extent of wheat crop damage.

In summary, the information system, as it now exists for both wheat production and wheat rust control, is highly dependent on published material, and long lead times are needed to gather information through ground surveys. Ideally U.S. acreage allotments in June should compensate for expected world harvest in July and August, for the anticipated yield, and for current carryover stocks. Today it is virtually impossible to know the worldwide wheat status at planting decision time. The objective is to provide for domestic consumption and exports with minimum carryover. At acreage allotment decision time it is necessary to know U.S. current carryover and expected yield of growing wheat as well as expected yield for the rest of the world. (Wheat rust control, of course, affects the expected U.S. yield.)

B INFORMATION AND DATA REQUIREMENTS

1 Pacific Northwest Water Management

The discussion in the previous subsection on the existing water management information network in the Pacific Northwest indicated that improved forecasts of water flows would permit water managers to realize increased benefits. To improve upon the existing information it is necessary to have better forecasting models, and these in turn require better source data. The data needed are the following:

- Snow area
- Snow depth
- Precipitation areas
- Precipitation rates (rain and snow)
- Surface temperatures
- Soil moisture
- Surface water areas
- Distinction between open water and ice
- Conditions of vegetation

A river basin is made up of subbasins each of which contributes to the volume of river flow as a function of time. The above data items are needed by hydrologic models to forecast volume and timing of water runoff in each subbasin.

Snow depth may be obtained by relating to objects of known height and by albedo (i.e., measuring the fraction of incident light that is reflected by the snow). New snow and snow depth may be measured by albedo reduction from protruding rocks and bushes. Conceptually it may be possible to develop a radar to sense snow depth directly by measuring the difference in reflection between frequencies that differ in their penetration of snow (although such an instrument is not currently under development). Surface temperatures assist in estimating precipitation quantity, soil moisture, evapotranspiration conditions, and snow melt.

2 Wheat Crop Management

Improved information to realize benefits from wheat crop management involves timely knowledge of the number of acres of wheat in production and the yield per acre expected from the various growing areas. The remotely sensed data needed is the following:

- Wheat recognition
- Plant location and acreage
- Plant density, color, and temperature
- Plowed land
- Wheat being harvested
- Ground temperature
- Precipitation
- Snow cover
- Soil moisture

3 Wheat Rust Control

The control of wheat rust and estimation of decrease in yield due to rust involves timely detection of rust infection and knowledge of climatic conditions affecting the development and spread of rust. The data needed are:

- Wheat crop identification along with stage of growth
- Identification of areas with rust severity greater than 25 percent
- Plant and ambient temperature difference
- Precipitation areas
- Free moisture
- Soil moisture
- Cloud velocity

C GENERAL CONFIGURATION FOR A SATELLITE-ASSISTED INFORMATION SYSTEM

This subsection describes the basic concept of a satellite assisted information system proposed in response to data requirements indicated in subsections A and B above. It should be noted that the system was conceived on a point design basis rather than on a basis of parametric design studies. Hardware that could be incorporated in the point design concept either exists or is in a predictable stage of development. The system as conceptualized is capable of providing the data considered necessary for improvements in water management, wheat crop management, and wheat rust control.

The general concept of the complete system is shown in Exhibit 5. The system is grouped under six main headings, which are numbered on the exhibit in accordance with the numbering of the paragraphs which immediately follow.

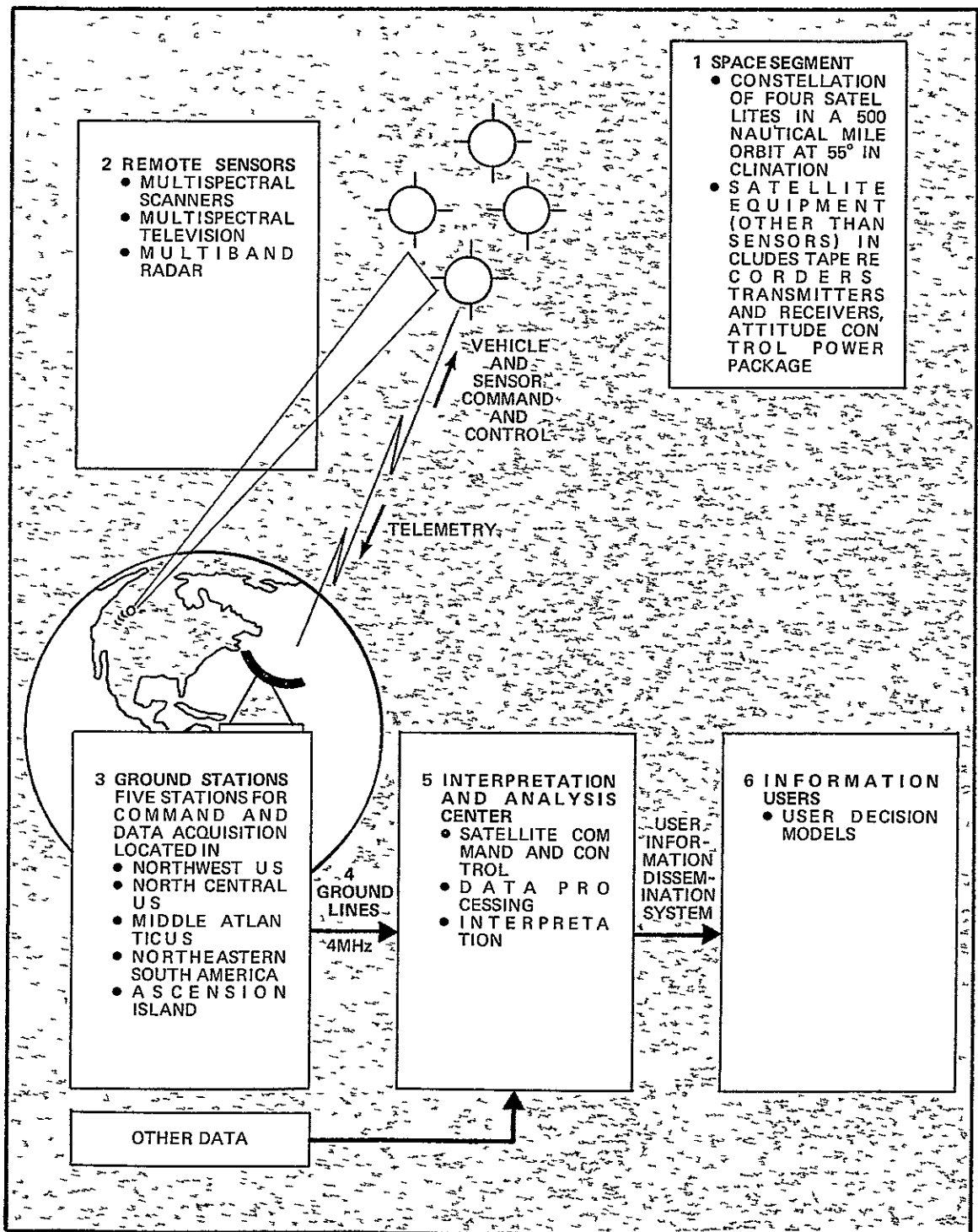

Exhibit 5 General System Configuration

1 The Space Segment

The satellite constellation (or orbital arrangement and spacing) must satisfy three requirements. First, the orbital altitude and the viewing angles of the sensors must permit the earth to be viewed with the planned swath width and resolution. Second, the orbit must cover the desired portions of the earth. Third, the satellite must transmit data on each area as frequently as desired. To do this, it must pass over both the observation area and the ground receiving station at appropriate intervals. The orbital pattern that satisfied these requirements is indicated in Exhibit 6, which shows the paths of four satellites in circular orbits plotted on a map of the world.

For Pacific Northwest water management, four viewing opportunities per day, spaced 6 hours apart, are necessary. The orbital constellation to accommodate this requirement will consist of four satellites each appearing over the same region on earth every 6 hours. That is, the four orbital planes have their respective ascending nodes (at the equator) 6 hours apart. The same satellite constellation is adequate for the coverage required for wheat crop management and wheat rust control.

Altitude and inclination specifications for the satellites were obtained by analyzing the area to be covered, the resolutions of the sensors, and other parameters. Computer calculations based on NASA data were used to obtain the best parameters. The chosen orbit is circular, inclined 55° , and at an altitude of 500 nautical miles.

The area of interest for the regional water management study is the Columbia River Basin, which lies between longitudes 125° and 110° W and between latitudes 42° and 52° N. The area to be observed for wheat rust in North America lies between latitudes 20° and 58° N. For the global wheat inventory/yield case, the areas that must be covered extend around the world between latitudes 58° N and 50° S.

Using the orbital pattern selected it is possible to calculate probability of coverage for each of

the three cases studied. In Exhibit 7 the probability of coverage is shown for one, two, and four satellites. Although wheat rust control requires two satellites and water management requires four satellites, the cost of the conceptual system was based on a four satellite constellation and the benefits were based on coverage probabilities given.

The individual satellites that carry remote sensors to accomplish the mission (discussed below under a separate heading) consist of the following: a structure subsystem, a propulsion subsystem for stationkeeping, a navigation and guidance subsystem, a stabilization and control subsystem for attitude control, a communications subsystem for telemetry, tracking, and command, a data management subsystem for data storage, and an electrical power subsystem. The power package will supply about 1,000 watts, and the total estimated weight of the satellite vehicle is 2,800 pounds. The complete satellite can be lifted into orbit by an existing TITAN III X/HOSS booster. Sixty-eight spacecraft will be required over the 18 years of operation, assuming a spacecraft mission lifetime of 16 months and a reliability factor of 0.9 for each spacecraft and launch vehicle.

2 Remote Sensors

Willow Run Laboratories furnished the basic information and technical judgments on available sensors. Altogether, five sensors were given serious consideration for inclusion in the sensor package. Three of these, the multispectral scanner (MSS), the multispectral television, and the multiband radar, were chosen as capable of measuring the parameters required for both the water management and agricultural applications. A tabular comparison of sensor performance specifications related to major hydrologic parameters is shown as Exhibit 8. Advanced Level I sensors appear to be adequate initially to provide the information necessary for water management. Selection of this package for the present conceptual system should in no way suggest any reduced requirements for further research and development of other sensor systems, particularly the passive microwave and laser techniques.

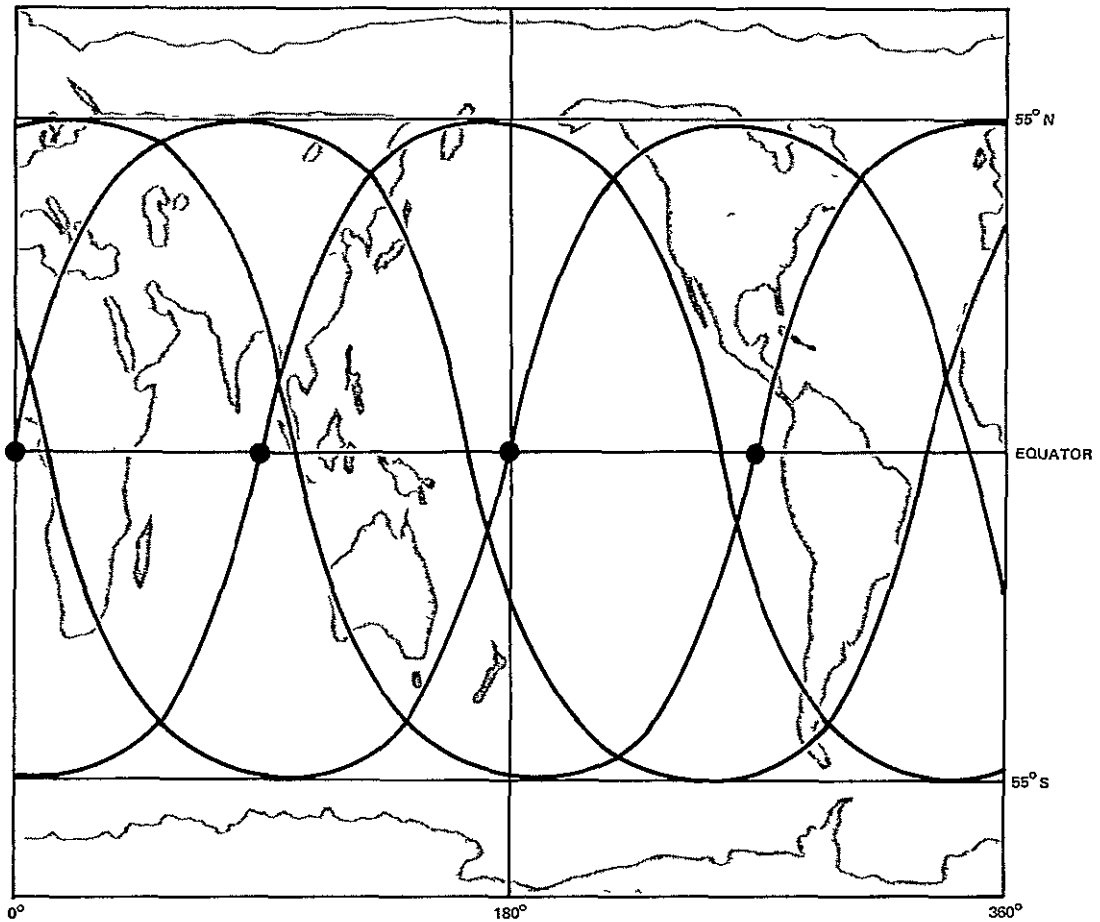

Exhibit 6 Orbital Pattern Four Satellites

a Multispectral Scanners

Exhibit 9 contains a summary of the design and performance characteristics of a multispectral scanner system that in WRL's technical judgment would be feasible to place in orbit by 1973. This design achieves a ground resolution of 1800 feet over a swath width of 320 nautical miles, using a rotating mirror to give a circular scan that advances along the ground beneath the satellite. The system provides coverage in seven spectral channels ranging from 0.5 through 12.5 microns (including the visible,

near-infrared, and thermal infrared regions). The radiation received from each resolution element on the ground is separated into its spectral components in such a way as to maintain registration of the signal outputs of the individual detectors.¹ This arrangement for maintaining registration permits the automatic processing of the signal outputs by ground based data processing equipment to perform

¹Willow Run Laboratories, WRL Report No 7610-5 F, *Dispersive Multispectral Scanning*, Ann Arbor, September 1966

Exhibit 7 Probabilities of Coverage Using 55° Orbit Inclination Angle
360 Nautical Mile Swath Width and 500 Nautical Mile Altitude

Case Study	Desired Frequency of Coverage (Daily)	Latitude Band To Be Observed (Degrees)	Probability of Coverage Using Equally Spaced Orbit Planes		
			One Satellite	Two Satellites	Four Satellites
Pacific Northwest water management	4	42-52	N/A	N/A	94
United States wheat rust control	2	20-58	N/A	73	93
Global wheat management	1	0-58	66	88	99

Exhibit 8 Sensor Resolution Capabilities

Information Required	Advanced Level I Sensor Resolutions			Advanced Level II Sensor Resolutions	
	Multispectral Scanner(1)	Multispectral Television(2)	Multiband Radar(1)	Laser	Microwave Radiometer
Snow area	1 800 ft.	100 ft.	1 800 ft.	—	—
Indicators of snow depth relative to objects	—	100 ft.	—	Potential capability	—
Indicators of snow depth by albedo (light reflectance) measurements. Identification of new snow and possibly snow depth	200 ft. and $\pm 3.5\%$ reflectance	Potential capability	—	—	—
Rain and snow rates of precipitation	—	—	1 800 ft. and 0.5 in depth	—	7 000 ft. and up to 2.5%
Precipitation areas	5 000 ft	5 000 ft	5 000 ft.	—	—
Surface temperatures	2 400 ft and $\pm 1^\circ F$	—	—	—	—
Soil moisture	1 800 ft. and ± 1 point	—	50 ft. Potential capability	—	7 000 ft. Indication of moisture in top 2 in
Surface water areas	200 ft.	100 ft.	200 ft	—	—
Distinction between open water and ice Condition of vegetation	—	—	1 500 ft	—	—

Notes (1) Is able to sense rain or snow
 (2) Is able to sense snow

detection and identification functions useful for agricultural and hydrological applications. The sensitivity of each of the visible and near-infrared channels is high enough that a change of reflectance in the observed surface from 20 percent to 20.8 percent will produce a signal equal to or greater than the detector noise. This noise level is considered to be small enough so that, even with additional noise introduced by tape recording and transmission to the ground, the probability of detection during automatic processing will not be appreciably reduced. The thermal infrared channel of the scanner, operating in the region of 10.5 to 12.5 microns, has a net equivalent temperature difference (NETD) of $0.4^\circ K$, assuming that both the filter and any subsequent optics are cooled, and a cold shield is used to restrict the field of view to 12° .

Additional improvement in scanner system performances beyond that described above could be achieved by continued research and development on scanner systems. It is estimated that before 1980, through the use of larger scanning mirrors, multiple array detectors, and more sensitive detectors, ground resolutions of 100 feet could be achieved for the same sensitivity.

b Television Sensors

Television systems for space application offer the advantages of being able to provide high resolution imagery, multispectral response, sensitivity for nighttime surveillance, and an output in an electrical form that is compatible with data link transmission. The factors that influence the usefulness of the imagery obtained are resolution, coverage (frame dimensions of swath width), sensitivity, and spectral response. These factors are not independent. Some of the relationships among the factors are simple (resolution and coverage), while others are quite complex (resolution and sensitivity). Of the two television systems of advanced performance shown in Exhibit 10, WRL projects that the first could be available for space use by 1973 and the second by 1980.

The ultimate ground resolution of a television system would be limited by the physical size and dimensional tolerances of the optical system. However, for the missions and ground rules assumed in this study, the system resolution is considered to

Exhibit 9 Multispectral Scanner Characteristics

Design Characteristics			
Aperture diameter 20 in			
Instantaneous field of view 0.083 milliradians			
Type of scan circular			
F number of optics 4.8			
Number of detectors per channel 6			
Information bandwidth 4.2 MHz at 30% duty cycle			
Weight 350 lbs.			
Sensor Performance			
Ground resolution (from 300 n.m.) 1800 ft			
Swath width 320 n.m.			
Sensitivity			
Channel	Detector System	NE $\Delta\rho$ (for $\rho = 0.2$) ⁽¹⁾	NE ΔT ⁽²⁾
0.5-0.6 microns	S 20 photomultipliers	0051	0.4° K
0.6-0.7	S 20 photomultipliers	0057	
0.7-0.8	S 20 photomultipliers	0076	
0.8-1.2	InSb at 77° K with cooled filter	0066	
1.55-1.75	InSb at 77° K with cooled filter	0058	
2.2-2.4	InSb at 77° K with cooled filter	0056	
10.5-12.5	Ge Hg Cooled filter and refractive optics with cold-shielded 12° field-of view		

Notes: ⁽¹⁾NE $\Delta\rho$ = net equivalent reflectance
⁽²⁾NE ΔT = net equivalent temperature

be determined by the resolution capability of the television sensing surface

Current operational systems such as TIROS typically use a camera with 1-inch vidicons and a 0.5- by 0.5 inch sensing layer format. Typical sensor resolutions are 800 television lines per frame and 30 line pairs per millimeter.

The current state of the art with regard to resolution capability in a laboratory environment is probably best represented by the RCA 2-inch return beam vidicon¹. This has a 1 by 1-inch image format and is capable of 5000-television line operation. The sensing-layer resolving capability is about 100 line pairs per millimeter. In the opinion of representatives from industry this laboratory device will be available for use in an operational satellite in about 4 years, about 2 years to produce a good prototype model and another 2 years to make it operational in space. This timetable implies that a 5000 line system could be launched in 1973 or 1974.

¹Return Beam Vidicon System Achieves 5000-TV-Line Resolution *Broadcast News* March 1968 No. 138

Exhibit 10 Television Sensors

Characteristics	Advanced Levels	
	1	2
Design		
Type	Return Beam Vidicon	Return Beam Vidicon
Lines per frame	5 000	10 000
Channels	3	3
Information bandwidth	1.25 MHz/channel	12.5 MHz/channel
F number	2	2
Focal length	8 inch	(1)
Size	1.5 cu ft./channel	5.0 cu ft./channel
Weight	30 lbs./channel	100 lbs./channel
Power	30 watts/channel	100 watts/channel
System Performance		
Ground resolution	50 ft	(1)
Swath width	50 n.m.	(1)
Dynamic range	100	100
Amplitude response at maximum resolution	15%	15%

Note: ⁽¹⁾Ground resolution and swath width objectives will determine focal length and orbital altitude tradeoffs.

c Synthetic-Aperture Radar

The feasibility of placing an appropriate radar in a satellite and the design problems involved were the subject of an intensive study con-

ducted by the University of Michigan for the U S Air Force under contract AF 33(616) 8365 The major conclusions and some design specifications are contained in the final report of this contract¹ In addition a summary of most of the pertinent information has recently been published as a set of summer conference notes² that can be used as a basis for satellite-borne radar design guidance

It is fortunate that off the-shelf equipment and well developed technology exist for designing and constructing a focused, synthetic-aperture radar, since it is the only type capable of reasonably fine resolution for satellite borne operation Once the satellite flight parameters are known and the required resolution and operating frequency of the radar are selected, the remaining parameters of an optimal system can be determined

The inclusion of radar in the sensor package is not intended to supplant either existing or planned ground radar systems In fact, a ground radar system, like the Hydromet telemetering system, can greatly assist a remote sensing system by furnishing complementary and ground truth data It should be emphasized that, although study limitations precluded a detailed examination of current and planned systems in other agencies, this study assumed that proposed conceptual system would not operate independently, and that any final operational satellite system would probably interface with a series of complementary ground systems

3 Ground Receiving Stations

To supplement existing NASA tracking facilities, five ground receiving stations are projected to track the satellites and collect sensor data The five locations would be in the Northwestern states, the northern Central states, the Middle Atlantic states,

¹Institute of Science and Technology of the University of Michigan, Final Report No AFAL TR 65-236 Willow Run Laboratories Report No 4563-107 I, *Radar Techniques for an Aerospace Vehicle* (U) November 1968 (SECRET)

²R.O Harger L.J Porcello, A Kozma, E.N Leith, A Olte R.K Raney T.B.A Senior, L.F Sellwig D.L Tyler *Principles of Imaging Radars* Notes of an intensive short course presented at the University of Michigan Engineering Summer Conferences, Ann Arbor Michigan, July 22 to August 2, 1968

northeast South America, and the Ascension Islands The alternative approach of a geo stationary tracking and data relay satellite system was not considered in this study

The equipment necessary for each ground receiving station is described below

a Antenna and Tracking Components

The tracking system includes the tracking antenna, the associated radio and computer equipment, and the mechanical means to rotate and tilt the dish Additional tracking equipment will be necessary to precisely locate the satellite for data It is assumed that the minitrack network already in existence can perform these functions

b Electronic Equipment

Electronic equipment includes parametric amplifiers, demultiplexing equipment (filters), line drives, and demodulators Dual video tape recorders are included in the ground station complement Other equipment includes the VHF receivers and transmitters and the computer equipment associated with command and encoding functions

4 Ground Lines

The conceptual system design uses ground lines to connect the receiving stations to the Interpretation and Analysis Center (IAC), and the IAC to the points of insertion into existing agency dissemination systems

Data from the ground receiving stations will be communicated to the IAC through leased wideband communication circuits The estimated ground network bandwidth required to carry both hydrological and agricultural data from the receiving station to the IAC is about 4 MHz Worldwide agriculture yield data will require 48 MHz and could be transmitted through data relay satellites

Dissemination to the information users from the IAC would presumably be through normal channels employed by the using agencies Domestic leased lines are capable of relaying hydrologic data to water management groups within the specified 6 hour

limit Established communication facilities between current operations centers and dams are sufficient to maintain control The existing control system in the Northwest is partially automated, and, even where manual, it is capable of continuous contact

5 Interpretation and Analysis Center

a IAC Design

The IAC serves several purposes First, it is a command and control center for continuous monitoring of the satellites, for producing tapes to be used by the ground stations, for interrogating the satellites, and for sending commands to the satellite sensors Second, it is a facility for processing the data from the satellites Personnel and equipment in the IAC receive, reformat, edit, scan, display, and otherwise evaluate the signals to reduce them to a data format useful for subsequent analysis Once the data have been reduced to the desired format, the IAC will serve as a dissemination point from which information will be sent to users

With the large volume of data provided by the sensors on the satellites emphasis is placed on utilizing automatic processing techniques As repeated observations increase the analyst's familiarity with the sensor data, as well as with the Earth areas to be covered, processing techniques will become increasingly automated For this reason, the personnel strength at the center is reduced toward the end of the program Another reason for the reduction in personnel levels is the reduction in programming effort as programs are developed and experience is gained in the first years of the operational system's performance

The IAC should include provision for appropriate involvement by the major interested user agencies This would ensure at all times that outputs from the IAC would be compatible with user requirements

For any of the applications under consideration in this study, the requirements for data processing were determined with the knowledge that it will not be necessary to process data from the ground regions of concern all of the time Rather, a sampling technique will be used selectively to process data only for those regions known from ground observations and predictions to be of interest at the

time (e g , changes in measurable parameters, such as extreme rainfall in the Columbia River Basin or drought in major wheat growing areas)

In the case of wheat rust, several measurable parameters must change to create a specific relation between them that fosters wheat rust formation and spread If the parameters are not seen to be changing toward the rust forming combination, it will not be necessary to process the data from that area If, however, it is predicted that conditions might be favorable for rust formation, the satellite data for that area would be collected and processed

b General Information Flow

Exhibit 11 illustrates the major steps of the IAC in processing data that will be received from the satellite via a ground receiving station in the form of an FM signal containing several channels of sensor and satellite housekeeping data The signal will be recorded on a master tape for backup and will simultaneously be decommutated or separated into discrete signals for each channel of each spacecraft sensor Each signal must also be converted into digital form by a series to parallel converter

Video data or data from one or more channels of the multispectral scanner will be converted into analog form and fed directly into a display device that exposes film that will be developed in the photo lab A Polaroid camera may also be attached to this device so that photographs are immediately available for making spot checks The display device can also add predetermined latitude/longitude grids to the photographs The resulting photographs will be used by photointerpreters

In addition, it may be necessary to utilize video data to determine the area viewed by the sensors Current techniques, which use satellite ephemeris data, timing, and sensor orientation, are accurate to within 1 or 2 miles The desired accuracy would be less than or equal to the resolution of the spacecraft sensors (less than one fourth mile) Photographs could be calibrated against a map to determine location to nearest sensor resolution element

It may also be desirable to feed the digital video signal into a digital computer for processing The digital computer can be programmed to mosaic and grid several frames, whereas the analog

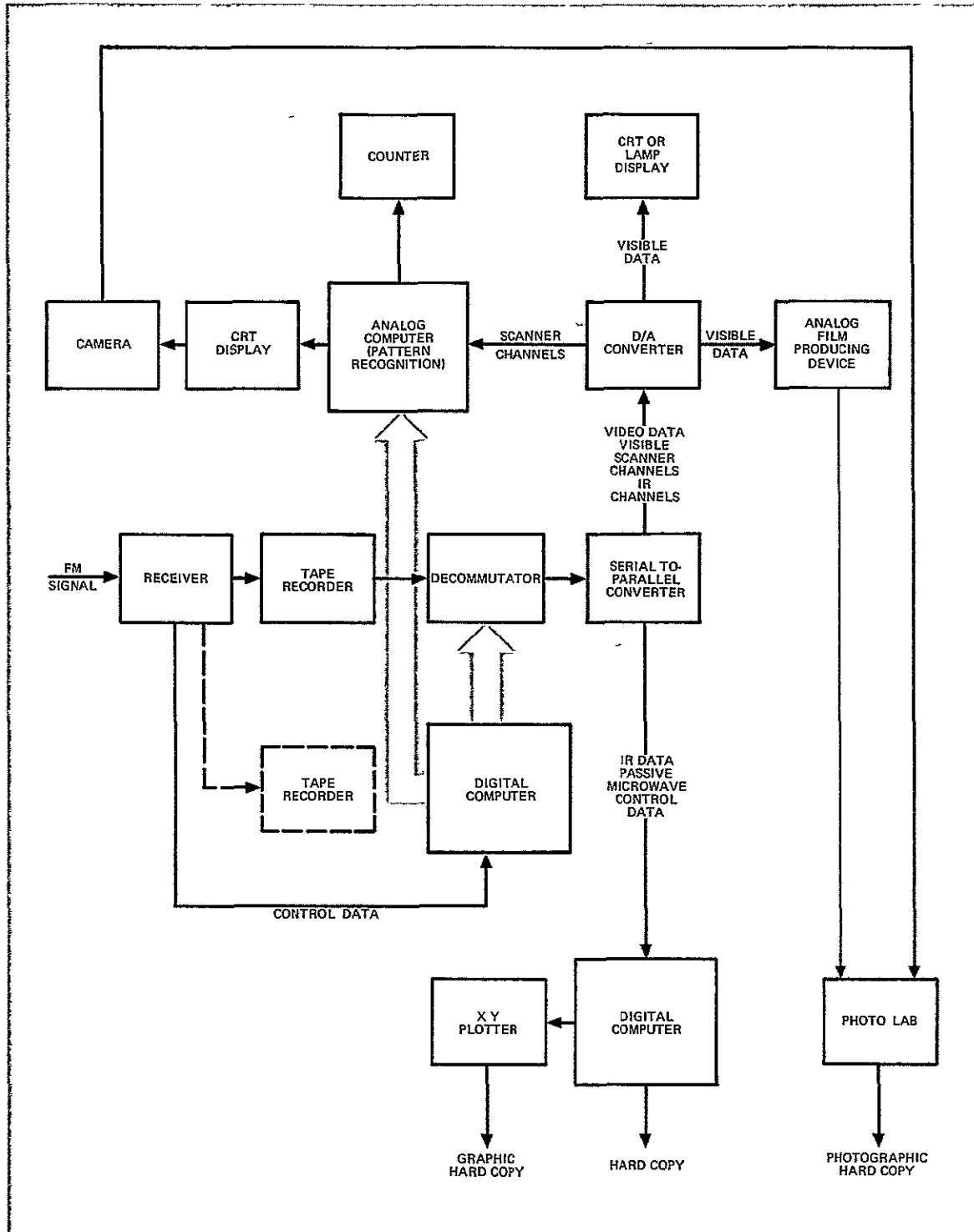

Exhibit 11 Interpretation and Analysis Center Data Processing Concept

method is limited to photographs of single frames. In addition, the digital computer has at least three other advantages. First, it may be programmed to enhance the discrimination available from the input signal. Second, it can produce photographs in various projections (e.g., Mercator) and correct for variations in sensor viewing angles, which is especially desirable if a sensor has an extremely wide viewing angle. Third, it can be used to eliminate duplicated or unusable areas from further processing. Duplicated areas may be eliminated by "remembering" areas covered by successive frames or passes. Unusable areas may be determined by detecting the presence of clouds, fog, and other conditions that would make the signals from the other sensors inaccurate or meaningless.

Digital processing of multispectral scanner data will primarily consist of computing temperature and surface moisture percentage by resolution element. Automatic corrections for atmospheric and surface conditions and differing instrument calibrations may also be possible. Outputs will be one or more of the following types: alphanumeric listings that display parameters by resolution element or summation of parameters by specified geographic areas, digital tapes containing information to be fed into the x-y plotters, digital tapes to be used by automated analysis models, and analog tapes to be used in photo-processing.

Multispectral scanner data will also be processed by the analog computer. The main purpose of this processing is to detect the existence of wheat, determine its stage of growth, and determine if wheat rust is present. The computer can also accumulate these parameters by specified areas. The results can be used to estimate wheat yield and assist in controlling the spread of wheat rust. This type of processing, called pattern recognition, is about 1,000 times faster by analog computer than by digital computer. State-of-the-art for this particular requirement of pattern recognition, however, is such that a considerable research and development effort might be necessary before automated processing can become fully operational.

Additional IAC functions include computation of various orbital parameters required by the monitoring center and processing of satellite housekeeping data to determine the condition of the spacecraft and sensors.

6 Information Users

The final link in the data flow chain is the user. It is anticipated that information processed through the IAC will be inserted at appropriate points in existing agency information or data systems. The models designed to use the data thus obtained are described in Section III.

III MODEL DESCRIPTIONS

III MODEL DESCRIPTIONS

A WATER MANAGEMENT

1 Selection of the Columbia River Basin

The impact of using information derived from data provided by remote sensors onboard satellites to improve water management was studied by analysis of a particular river basin system. The Columbia River and its tributaries (see Exhibit 12) represent a significant example of multi-purpose water management. The BPA¹, CE, Bureau of Reclamation, as well as other public and private groups are involved in regional water management to support hydropower generation, irrigation, flood control, navigation, and recreation. The models described in

this subsection were used to estimate potential benefits from improvements in water management for the entire Columbia Basin, made possible by data from a satellite assisted information system. In the study, three subbasins were selected for detailed analysis to provide a basis for estimating total basin benefits. The projections of potential benefits to the United States and to the rest of the world were estimated from the Columbia Basin work.

¹A close working relationship with BPA was established through a memorandum of July 25, 1968, from the Director of Geological Survey to the Administrator of BPA requesting assistance in this study.

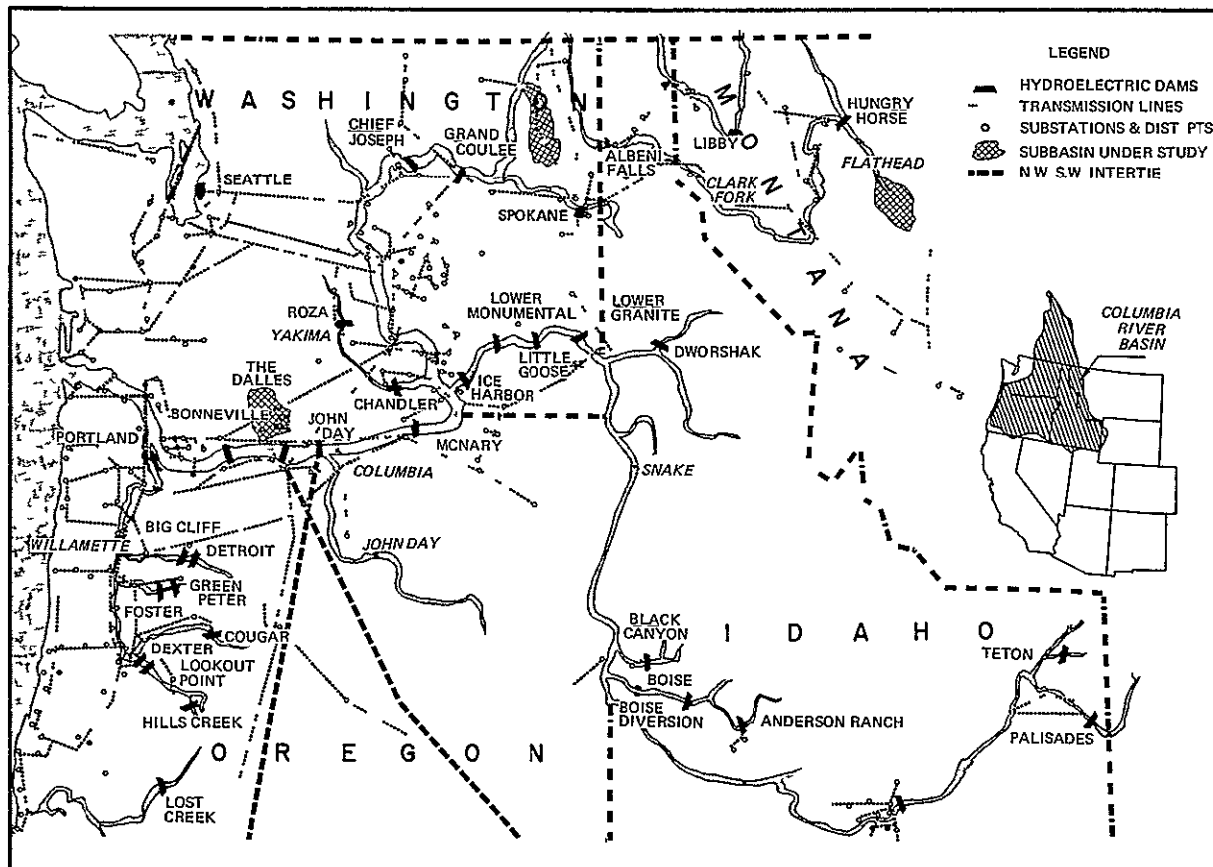

Exhibit 12 Columbia River Power System

Some indication of the scope of the current information network for the Columbia River Basin is to be found in the Hydromet system, which will incorporate approximately 100 automated river gauging and weather stations located primarily in various valleys of the Northwest during the next 3 or 4 years. This vast Northwest region includes approximately 360,000 square miles and contains about 57 separate important subbasins. Three of these subbasins which were studied intensively are indicated in Exhibit 12. It is important to note that snowpack inventories, rainstorms, and other hydrologic phenomena that directly influence runoff forecasts occur not only in the valleys but also in the piedmont and mountainous areas, where very few stations now exist. In these remote areas of the various subbasins, satellite remote sensing would be most useful. The use of a satellite assisted information system does not imply that elimination of existing or planned systems is being proposed or would be advantageous. On the contrary, it is expected that complementarity will exist among ground and space systems, and that synergistic benefits will occur with the systems in combination. Ground based observation stations provide essentially point data which are sometimes difficult to extrapolate to values for a large area. Satellite observations, on the other hand, inherently give broad area coverage but provide data that are sometimes difficult to use in establishing precise values at specific points on the ground.

2 The Water Management Problem

Current information systems operate with incomplete data, and management rules reflect such available data. Improved management techniques made possible by greatly increasing quantity and quality of data furnished by a satellite assisted information system would result in substantial benefits. New types of data, more timely data, and greater quantities of data will require development of improved hydrologic and system operation models to generate new types of water management information and consequently modified decision rules appropriate to the enhanced information.

The water management problem is primarily decisionmaking to control the water levels in dams and rivers to satisfy multiple purposes. Annual runoff at a major dam site may vary in any one year by as much as 30 percent above or below the long term average. Water management decisions must

be based on anticipated future volumes of runoff, hence accurate short- and long term forecasting is of paramount importance. When the future is uncertain, the use of historical records and safety factors will waste potentially beneficial water resources. For example, lacking better information, good management practice would require flood control managers to assume the coming season will be abnormally wet, while power managers should assume the same season will be abnormally dry. Satellite-assisted information for water management can result in actual benefits if the remotely sensed data can be translated into the information that is appropriate to a new set of water management decision rules.

Although multi purpose water management cannot independently optimize flood control, hydropower generation, irrigation, navigation, and recreation, hydropower management itself can be considered in terms of the following four basic elements:

- *Drawdown-refill strategy* is related to management of the various types of reservoirs, cyclical, annual, and run-of-the-river.
- *Interreservoir coordination* is concerned with the amount of water coming from tributaries between one reservoir and the next.
- *Head efficiency* involves maintenance of the maximum amount of water in the reservoir to obtain the greatest water pressure on turbines.
- *Hedge* is the amount of water that must be held for contingencies since forecasts are uncertain.

Currently the Columbia River Basin water is managed by relatively simple decision rules which, although compatible with available data, could be made more effective if basic data to support them were more complete. Collectively these decision rules are not always compatible with each other because the various decisionmaking agencies do not share common objectives. Improved and more complete data from remote sensors will generate increased benefits if the improved management information is used with improved and compatible decision rules.

3 Forecasting Models

Effective management of the Columbia River requires seasonal, monthly, daily, and even hourly forecasts. For example, flood control depends on knowledge of weekly and daily peaks, while power management requires 6-hour and even 1 hour forecasts.

a Overall Model Characteristics

The satellite-assisted information system is a major innovation that will provide data for many complex measurements to improve the forecast of water entering streams, rivers, and reservoirs. Exhibit 13, which shows the basic model for collecting and collating these data, illustrates that data gathered by satellite sensors will be used in a series of hydrologic models. The processed data would first go into an inventory/melt model that accumulates measurements on precipitation and snow melt. The output of this model is used by the surface, subsurface, and base water flow model. These two models provide basic inputs for the river runoff model that generates the information on reservoir levels. In the final step, information is supplied to the management function where it is combined with established policies and other constraints related to power, irrigation, flood control, navigation, and recreation. Throughout this process, meteorological data are also continually being acquired and used to complement the remote sensor observations to achieve the highest possible levels of forecast accuracy.

b Remote Sensor Data for Water Management

Initial interest in the contribution of remote sensors to water management is centered around snowpack measurements at the head of major rivers and their tributaries. It became apparent that many more measurements could be usefully furnished by remote sensors. Precipitation (either snow or rain) is important, as is the influence of physical and geological characteristics on water movement. The sensors have the capability to measure many of the relevant parameters directly, and others can be inferred by relating certain observations at critical time periods. The potential use of satellite based sensor data is illustrated in Exhibit 14. The important physical relationships in the basin are shown inside the boxes, and the potentially useful satellite observations relating to each are directed to the appropriate boxes by arrows.

c Runoff Model

Water managers need to know how volume of water runoff will vary with time after an impulse such as snowmelt or a rainstorm. The original impulse can be considered as comprising three components — surface runoff, interflow, and base flow — that contribute to the total hydrographic reading measured at the river gauge at the bottom of the subbasin. The peak flow for the various components occurs at different times after the impulse as shown in the typical impulse response in Exhibit 15. Surface runoff might peak at the river gauge about 1½ days

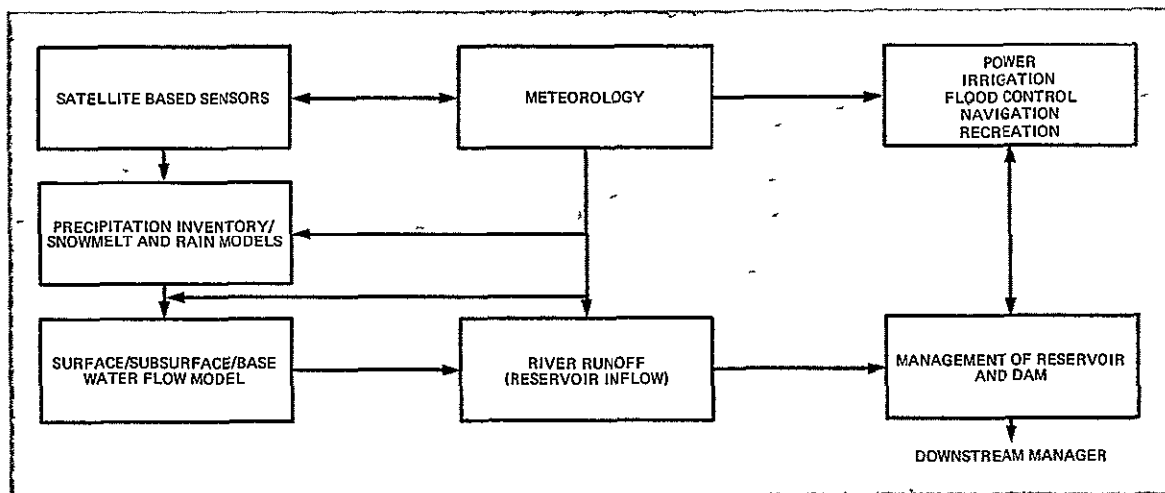

Exhibit 13 Simplified Water Management Model

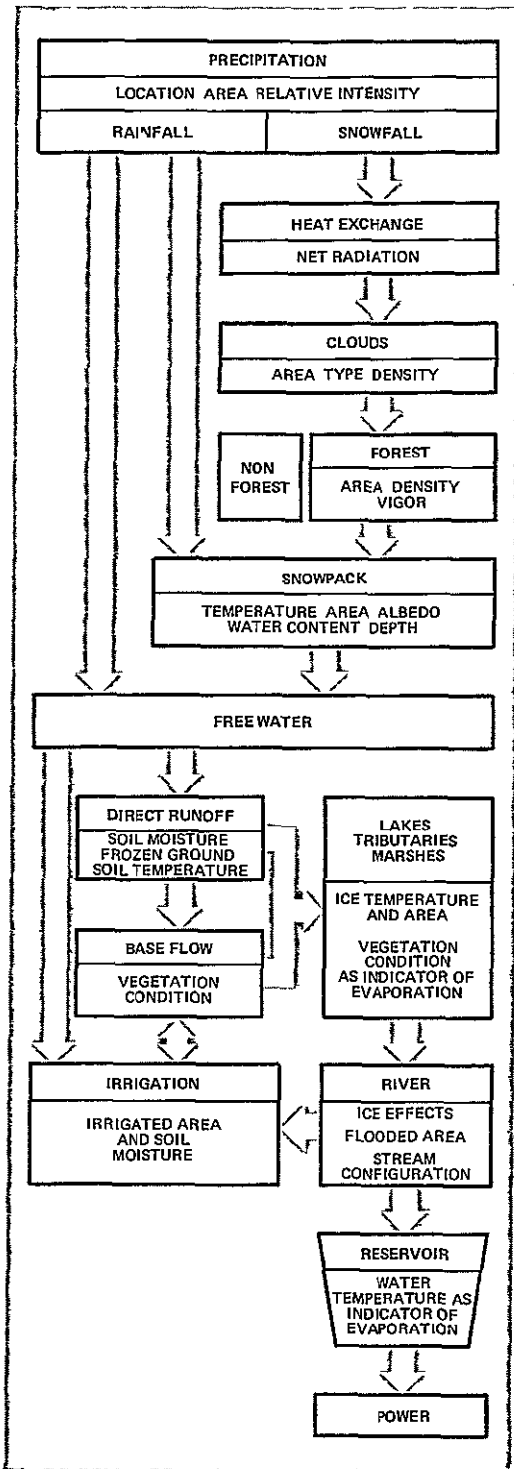

Exhibit 14 Contribution of Potential Remote Sensor Data To Water Management

after a rainfall Interflow might peak at two or more days after the impulse, and the base flow a few days later The timing of the surface, subsurface, and base flow runoff through the subbasin changes significantly with the type of subbasin, geological characteristics, and antecedent conditions (e.g., earlier rains, snow, droughts)

In this study, a runoff model was developed to simulate a subbasin hydrograph The runoff from a typical subbasin is affected by snowfields, marshes and lakes, rivers, soil moisture, varying ground cover, and soil conditions These factors influence the rate and level of stream flows moving into the reservoir and are accounted for in the runoff model

d River Model

The runoff model deals with the water entering a river from a subbasin, however, water managers are concerned with many subbasins, dams, and reservoirs Thus a model of a simplified river system representing the Columbia River Basin was developed to study the impacts of river management on total information requirements (see Exhibit 16) This river model considers subbasin runoff and different types of dams (cyclical, annual, and run of the-river) in simulating the impact of improved information not only on the operation of each type of dam but also on multidam management

4 System Integration

During the process of translating the initial systems concept into an effective configuration, it was necessary to go through several iterations of the

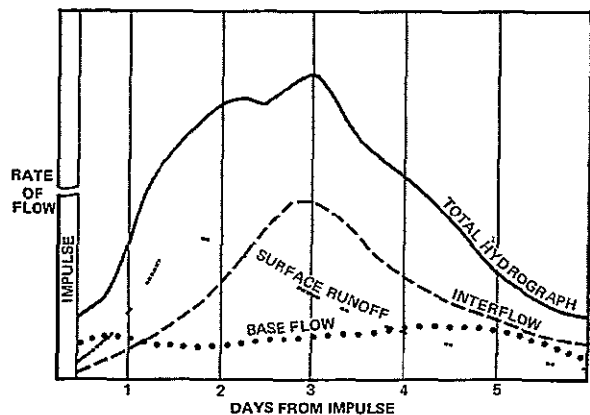

Exhibit 15 Runoff Hydrograph After Impulse

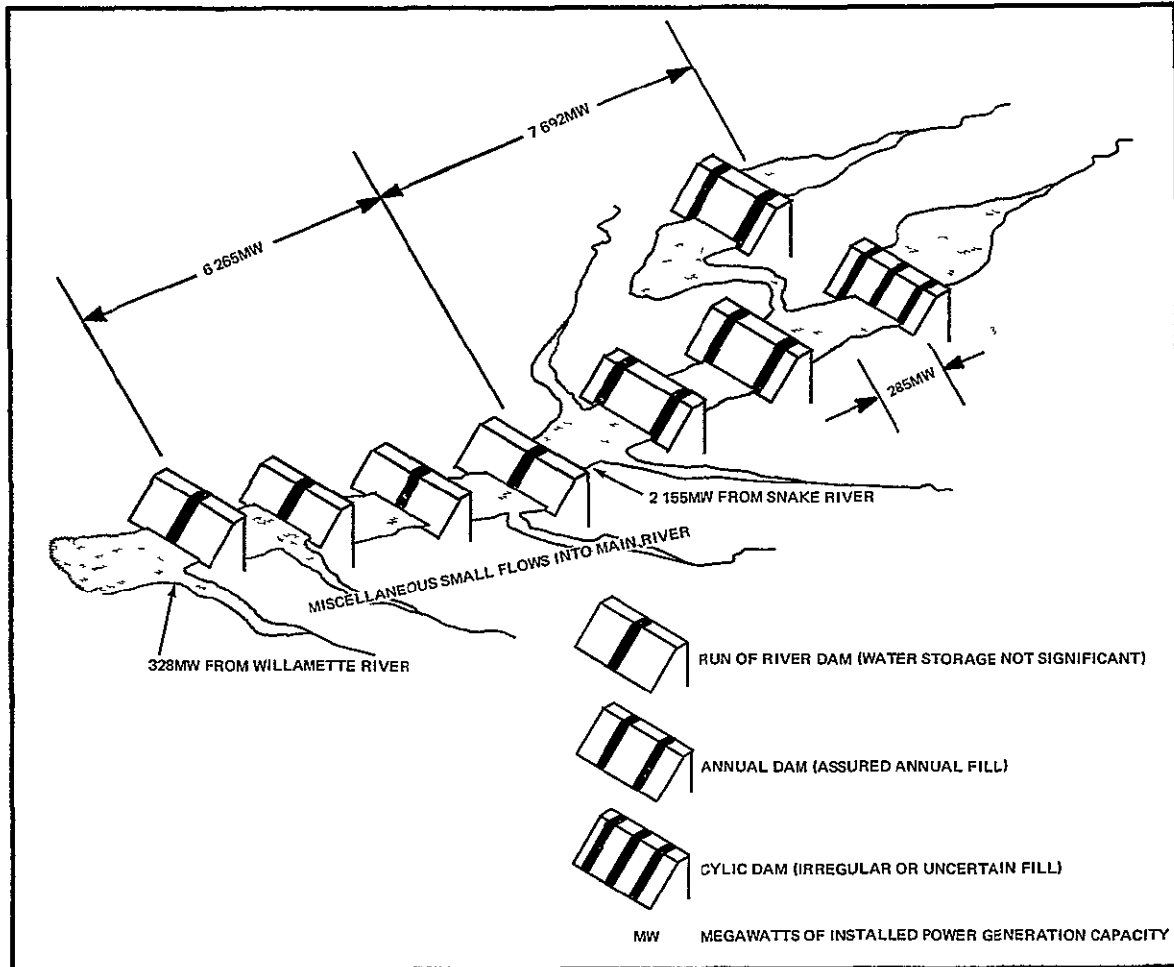

Exhibit 16 Expected 1975-80 Columbia River Basin Configuration of Dams and Power Generation Capacity

analysis before an integrated set of specifications could be achieved. This iterative process provided an improved configuration that ensures, for example, that increased power generation is not accomplished at the expense of increased flood risks, reduced allocation of irrigation water, or river depths unsuitable for navigation.

The required sensor capabilities to provide the measurements that are necessary inputs to earth resources models are related to the forecasts or predictions derived from these models. In turn, the predictions are needed in user decision models whose outputs are the basis for resource management decisions and benefits. This sequential chain of relevance or system dependency can be presented graphically in a set of related matrices whose format is explained by Exhibit 17. The particular matrices for water manage-

ment are shown in Exhibit 18. In the water management relevance matrices, the various types of sensors¹ are shown just above the lower right corner. Each sensor makes a contribution to the total physical measurement requirements by detecting such parameters as streamflow, rainfall, snow area (high level) and snow area (low level). These physical measurements are then used, for example, in making forecasts for seasonal snowmelt runoff or seasonal rainfall runoff.

¹The sensor matrix included a multispectral color television, a 7-channel multispectral scanner, multiband radar, a microwave radiometer, and an infrared scanner. However, only the television, scanner, and radar were selected for use in the conceptualized system.

The contribution of each measurement to the forecast is ranked 1 through 4. The number 1 means that the physical measurement is sufficient to make the forecast possible. The number 4 means that the physical measurement makes a slight contribution to the forecast. The number 2 signifies a major contribution and number 3 some contribution. In several

instances, two numbers appear in a cell, meaning that the value of the physical measurement to a forecast, for example, lies between the two values. All the physical measurements making a contribution will be used in making forecasts. The value of each measurement to a specific forecast and the value of each forecast to management decision and benefits is similarly

												MANAGEMENT DECISIONS AND BENEFITS						
MANAGEMENT DECISION MODELS																		
														SENSORS				
PREDICTIONS																		
													MEASUREMENTS					
EARTH SCIENCE MODELS														OBSERVATION SYSTEMS				

Exhibit 17 Format of Relevance Matrices

								MANAGEMENT DECISIONS AND BENEFITS	<div style="border: 1px solid black; padding: 5px;"> <p style="text-align: center;">LEGEND</p> <p>1 SUFFICIENT</p> <p>2 MAJOR CONTRIBUTION</p> <p>3 CONTRIBUTION</p> <p>4 SLIGHT CONTRIBUTION</p> </div>					
2	2	2	3	3	2	2		DRAWDOWN REFILL STRATEGY						
3	3	2	3	3	3	2		INTER RESERVOIR COORDINATION						
3	3	2	3	2	2	2		HEAD EFFICIENCIES AND HEDGE						
2	2	3	3	2	3	4		FLOOD CONTROL						
2	2	3	2	3	3	4		IRRIGATION						
								SENSORS						
PREDICTIONS	SEASONAL SNOW MELT RUNOFF	SEASONAL RAIN FALL RUNOFF	STREAM FLOW SURFACE	STREAM FLOW GROUND WATER	STREAM FLOW MAXIMA	STREAM FLOW MINIMA	LOAD VARIATION (POWER)							
									MEASUREMENTS					MULTISPECTRAL TELEVISION
	3	3	2	2	2	2	4		STREAMFLOW (ANTECEDENT)	3	3	3		
	4	2	2	2	2	3	4		RAINFALL	3	3/4	2	3	3
	2	4	3	2	3	3	4		SNOW AREA HIGH LEVEL	2	2/3	2/3	3	3
	3	4	3	3	2	3	4		SNOW AREA LOW LEVEL	2	2/3	2/3	3	3
	2	4	3	2	3	3	4		SNOW WATER EQUIVALENT HIGH	2/3	2/3	2/3	3	3
	3	4	3	3	2	3	4		SNOW WATER EQUIVALENT LOW	2/3	2/3	2/3	3	3
	3	4	3	3	3	3	4		SNOW TEMPERATURE HIGH		2		3	2
	4	4	3	3	3	3	4		SNOW TEMPERATURE LOW		2		3	2
	3	4	3	3	3	3	4		SNOW ALBEDO HIGH	2/3	2			
	4	4	4	4	3	3	4		SNOW ALBEDO LOW	2/3	2			
	3	3	3	3	3	3	2		AIR TEMPERATURE		2		2	2
	3	3	3	3	3	3	4		GROUND TEMPERATURE		2		2/3	2
	3	2	2	2	2	3	4		SOIL MOISTURE	2/3	3		2	2/3
	2	2	2	3	3	3	4		EVAPOTRANSPIRATION		3		2/3	2/3
	4	3	4	4	4	4	2		CLOUD COVER	1/2	1/2			1/2

Exhibit 18 Sequential Matrices Relating Sensors To Water Management

ranked by placing an appropriate number, 1 through 4, in each cell

The matrix presentation provides a convenient means to show the relationship between water management decisions and remote sensor capabilities through the intermediate steps of forecasts used by management and measurements needed to support forecasts. For example, forecasts of seasonal snowmelt runoff make a major contribution to irrigation management decisions and, hence, benefits through more effective use of water. In turn, measurements of high level snow areas make a major contribution to forecasts of seasonal snowmelt runoff. Finally, the matrix shows that the three types of remote sensors proposed for the satellites in this study (multispectral television, multispectral scanner and multiband radar) all make major or, at least, significant contributions to measurements of high level snow areas.

The matrix indicates that the multispectral scanner is the only sensor making a contribution to all the measurements listed, in many instances, the contribution is major. However, the multispectral scanner alone would not provide all the observations needed for water management. Short-term phenomena such as major rainstorms and amounts of rain are better observed by radar. Cloud-penetrating radar and ground mapping radar with 50 foot resolution would be needed to obtain accurate and timely data. Equally significant is the need for independent alternative means of observing the same phenomena to improve reliability and accuracy through data redundancy.

5 Scenario Analysis

A primary goal of the study was to develop models capable of utilizing data from remote sensors to predict basin and river runoff volumes. This analysis revealed that significant additional research is required in the earth-based sciences before suitably accurate subbasin and river runoff models can be developed. Some calculations of river flow are possible with the aid of available computer models. These models, however, are complex and not in general use. In any event, neither the existing models used in the Pacific Northwest nor those developed for this study permit explicit quantitative formulation of a system description that can relate all system elements from the acquisition of data by remote sensing to reservoir

inflow estimates to total river basin operation and finally to potential benefits.

As an alternative simulation method, a scenario analysis technique was developed to a level consistent with the accuracies that might be anticipated with a satellite-assisted information system. Using this technique, a scenario of important and representative events was prepared for a selected subbasin. The scenario simulated the hypothetical effects of snowfall, snowmelt, and rain on stream levels under varying temperature and vegetation conditions. Using cloud cover as a constraint, the capacity of the remote sensors to identify these critical events was then established. Finally, simulation experiments were conducted to verify the model.

An example of the use of scenario analysis to test the problem of snow cover observation is given below. The proposed satellite assisted information system will facilitate an accurate determination of snow inventory—a major parameter in forecasting water runoff. Procedures now used are not adequate to provide a continuous flow of information from remote regions. Snowfall accumulates in a step-like pattern that can be monitored from satellites, provided there are a sufficient number of cloud-free days for observation. Although the Pacific Northwest has many cloudy days, historical meteorological data indicate there are a sufficient number of days with a 0.9 probability of successful observation. Exhibit 19 illustrates the snowfall pattern and the probability of observing snow levels at a remote Montana station during one of its worst snow years. Cloud cover data for that year, however, indicate that from 2 to 12 satellite observations would have been possible at each step of snow level change. This observation capability is adequate to maintain a continuous inventory.

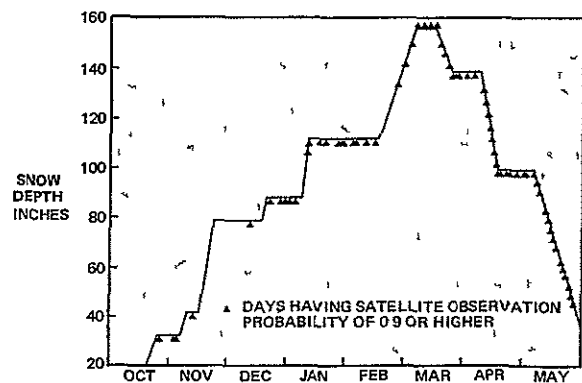

Exhibit 19 Seasonal Variation in Snowpack
(Data from Northwestern Montana for 1955-56)

of snow accumulation. Furthermore, during the critical melt period when the snow inventory is declining rapidly, there are more cloudless days and hence an increasing probability of observation for each satellite pass.

6 Detection and Verification

In addition to having a sufficiently high probability of favorable meteorological conditions for observation, it is necessary that sensors detect the selected phenomena accurately and reliably. Indications are that, when multispectral signature readings of selected earth phenomena are extrapolated to satellite altitude, only three of seven available channels in the multispectral scanner are required on each pass to obtain a probability of correct identification over 0.90 and a probability of false alarm less than 0.001. The probability of detection of wet soil is 0.99, while the probability of false alarm is only 0.001. The probability of detecting snow cover is 1.0 and the false alarm probability is 0.0.

The probability of correct identification will increase rapidly as the number of observations increases. When the number of observations is increased from one to four, the probability of correct identification increases from 0.90 to 0.99. In addition, repeated independent observations will reduce resolution error. There are, however, other means to verify observations. First, as seen in Exhibit 17, more than one type of sensor may be capable of observing the same phenomenon. For example, soil moisture can be observed by multispectral television and multispectral scanners. Second, verification can be improved by comparing remote sensor observations with measurements made on the Earth of the same phenomenon (Earth truth observations). In addition, Earth truth observations permit the conversion of relative measurements from remote sensors to absolute measurements.

A third important means of verification is the possibility of obtaining information by observing or calculating different phenomena. For example, the melting snowpack may be releasing water. The quantity of water released may be estimated by (1) actual observation of reduction in area of snowfield, (2) calculated reduction in area from observed temperature, winds, and rain, and (3) observation of increased size of marshes, lakes, or river flood plains. In this case, three independent estimates of one parameter (quan-

tity of water released) can be made from observation of different physical events.

Remote sensors frequently are more accurate in measuring relative differences than absolute levels. By calibrating satellite precipitation observations against a true ground observation, the relative values from satellite observations can be converted into absolute values. Finally, the frequent observations obtainable from satellites will also permit the development of new predictive patterns.

7 Dynamic Sampling Technique

Under operational conditions (in contrast to those during research phase) it is not necessary to provide redundancy of data yield for identification accuracies greater than 99 percent. Furthermore, data redundancy causes difficulties by requiring greater power for sensor (particularly radar) operations, and requiring increased telemetry along with consequent expanded data processing and interpretation facilities.

Dynamic sampling techniques can be developed and applied to take advantage of the relatively frequent and extended steady state conditions in nature, that is, sampling would be used to identify changes. As an example, in the case of the snowpack buildup and decline shown in Exhibit 19, it would not be necessary to obtain more than two or three observations of each step in the snow accumulation. Further, since each step in the snow depth accumulation pattern tends to follow a particular contour on a given mountain or range, it may not be necessary to observe the entire snow field.

The purpose of dynamic sampling is, of course, to reduce costs of the satellite and ground receiving and -processing stations without sacrificing usable accuracy or reliability. The persistence of steady-state conditions in nature makes this technique suitable for water management as well as wheat crop control and wheat rust prevention.

B WHEAT CROP MANAGEMENT

1 Background

Since wheat is one of the world's major food grains, fluctuations in annual production caused by errors in planting decisions and the effects of weather on crop yields significantly affect world food

supply The droughts and resulting famines in India during the mid-1960's are an example of the impact wheat crop fluctuations in one country can have on the world market A satellite assisted information system can contribute to better decisionmaking in the management of wheat production and trade in the United States and other countries Improved management decisions could reduce much of the annual global fluctuation in wheat production with consequent reduction in food shortages or better allocation of resources

The locations of major world wheat production areas are shown in Exhibit 20 The northern United States, Canada, and the Soviet Union are the principal spring wheat producers, while the remaining countries produce mainly winter wheat The locations of principal corn, sorghum, millet, and rice production areas are shown in Exhibit 21 These grains should be monitored since they are important food grains in other parts of the world and may be substituted for wheat in both production and consumption

In this study, management of US and world wheat crops was separated into an inventory problem and a yield problem Inventory is defined as the number of acres of wheat planted worldwide, and yield is the quantity of wheat produced on those acres

2 The Management Problem

Currently the total production of wheat amounts to 10 billion bushels yearly with an annual growth rate of 2 percent The annual fluctuations in production can reach as much as 10 percent Analysis of past estimates of world wheat production at harvest time indicated errors of ± 13 percent Historically, it has not been possible to reduce the error in estimation of the world harvest to as low as ± 2 percent until approximately 15 months after the actual harvest has been completed The analysis in this study indicates that remote sensor data can be used to reduce the current ± 13 percent error in wheat production estimates at harvest time to about ± 2 percent

The potential users of satellite assisted information for wheat inventory/yield management include the US Department of Agriculture [in particular the CCC and the Agricultural Stabilization and Conservation Service (ASCS)], US wheat producers, domestic manufacturers of farm input supplies, foreign governments, and foreign private producers

The principal management decisions in the United States faced by the Department of Agriculture are (1) determining the size of acreage allotments for the coming planting year and (2) deciding how large CCC stocks should be to hedge against potential disasters The United States has assumed and will probably continue in the role of balancing the world export/import wheat market Shortages abroad have been met principally by drawing from the planned or inadvertent US stocks that have exceeded domestic requirements In the future, stock reductions and world shortages are likely to continue to be made up by increased domestic production On the other hand, anticipated large crops overseas tend to result in reductions in US acreage allocations Determining the optimum domestic acreage allotment is a difficult task for a number of reasons One reason is that both winter and spring wheat are grown in this country with the latter planted some 8 to 10 months after the announcement of acreage allotments Another reason is that some farmers have the alternative to plant either winter or spring wheat The major reason however, is the lack of information concerning the status of world wheat crops and the anticipated size of the forthcoming harvest Thus, monitoring both domestic and foreign wheat inventory and yield is essential to avoid serious shortages or excessive domestic surpluses in the carryover inventories

The current decision process is largely based on quarterly forecasts of world production now made available by the US Department of Agriculture, with overseas forecasts from its Foreign Agriculture Service The data collection processes create a time lag, thus, forecasts are not reliable at the time of decisionmaking and do not permit significant modifications to be made during the production year Wheat growing in the Southern Hemisphere is 6 months out of phase with the Northern Hemisphere Although total wheat production of the Southern Hemisphere is considerably less than that of the Northern Hemisphere, it should be noted that Australia and Argentina are major wheat exporters With the bulk of production and consumption in the Northern Hemisphere, the inventory/yield information problem must be handled on a near real time basis

3 User Models

The selected system concept involves continuous satellite monitoring of production activities and environmental conditions between land preparation and harvest in all wheat producing areas of the



Exhibit 20 Regions of Principal World Wheat Production

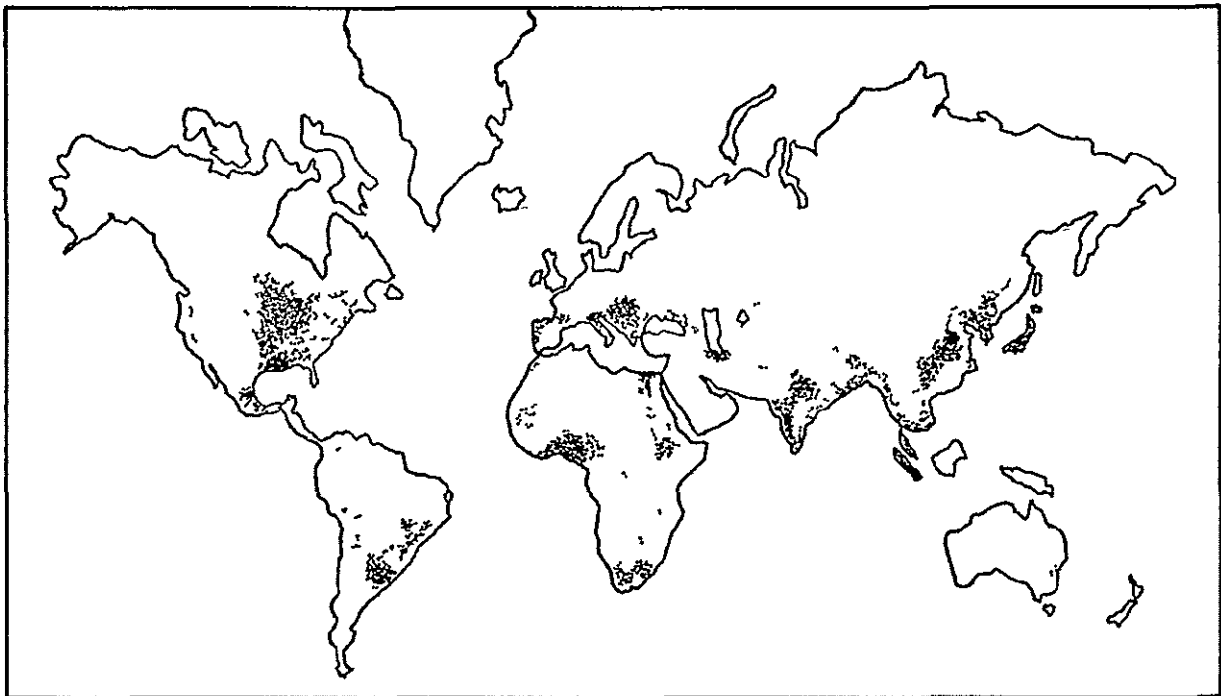

Exhibit 21 Regions of Principal World Corn, Sorghum Millet and Rice Production

world. The observed data would be evaluated and used to support periodic forecasts of the estimated number of bushels that will be harvested subsequently. As the crop season progresses, the forecast accuracy would progressively improve, culminating in the most accurate estimate at the time of harvest. After harvest, a further refinement in final harvest forecast could be expected by following those post-crop reporting procedures now used.

Identification of wheat acreage is a relatively straightforward process, but analysis of anticipated yield requires a more complex model. Yield forecasts require frequent monitoring of temperature, precipitation, soil moisture, stress, growth stage, and other factors that are either directly or indirectly indicative of the crop vigor. Signature data analyzed by Willow Run Laboratories indicate that wheat fields can be identified with a high degree of reliability and that other sensor data can be used to make yield estimates.

Under the current system, USDA uses a four-step model that considers domestic consumption, current carryover stocks, U.S. exports, and current production to determine wheat acreage allotments. Consideration was given to this model as the basis for developing wheat management benefits. This initial study concept was intended not only to estimate wheat allocation but also to describe the manner in which the satellite-assisted information system could aid planners in effectively allocating resources for wheat production. The satellite system conceptualized in the study is an information system intended to give USDA decisionmakers better and more timely information for a variety of policy decisions, not just those related to wheat acreage allocations. As a corollary problem, it is evident that adaptation of an operational system similar in concept to the one described herein undoubtedly will require reappraisal of major policy and legislative issues. One example might be consideration of the frequency with which acreage allocations could be revised through the growing season. No attempt was made to adjust the findings of the study to possible legislative or policy changes. Besides being outside the scope of this project, a study of legislative implications would have required an inordinate amount of political speculation. The assumption was made, therefore, that legislative and policy issues resulting from an operational satellite system could be resolved satisfactorily. The work in this study, however, used existing legislation and policy guidance.

The problems of wheat crop management should not be limited to the study of wheat alone, since it is possible to substitute other grains for wheat in the production cycle to meet total consumption requirements. An analysis of the elasticities in production and consumption was undertaken, but no simple generalization emerged. Clearly, a more complicated multigrain model must eventually be designed to make full use of satellite-assisted information in the management of world grain crops. The immobility of some resources may give rise to some reduction in benefits not analyzed in the present study.

4 System Integration

The interrelationships among sensors, forecasts, management decisions and benefits are indicated in the system relevance matrices (Exhibit 22). The lower right corner indicates the sensor observations that could contribute to the various physical measurements such as temperature, moisture, or presence of wheat plants. The numbers indicate the degree to which particular sensors could contribute to the measurements (The ratings of 1 through 4 have the same meaning as on the similar matrix in water management). The forecasting elements in turn contribute to the management areas/benefits at the top of the matrix. The study indicated that a satellite-assisted information system for wheat management is susceptible to more improvements and greater benefits from further studies of sensor signature recognition and of physical relationships in earth and agricultural sciences than from improvement in sensors *per se*.

A simulation technique similar to that used in water management was adopted, and a scenario was developed to describe the various events that must be measured during plowing, planting, cultivating, and harvesting of wheat. The effects of weather, stress, and other factors on crop development were established using available USDA research. The points at which the remote sensors could identify events and other parameters were established, and the cumulative accuracy of the satellite-assisted system was estimated.

Much of the work discussed under water management, including sensor techniques, meteorology, hydrology, and other earth sciences, is applicable to agricultural management. Techniques of pattern recognition, repetition of observations, and corroboration

								MANAGEMENT DECISIONS AND BENEFITS	<div style="border: 1px solid black; padding: 5px;"> <p style="text-align: center;">LEGEND</p> <p>1 SUFFICIENT</p> <p>2 MAJOR CONTRIBUTION</p> <p>3 CONTRIBUTION</p> <p>4 SLIGHT CONTRIBUTION</p> </div>				
2	2	2	2	2	2	2	2	CCC SAVINGS					
2	2	3	2	2	2	2	2	PRODUCERS OPTIONS					
2	2	2	2	2	2	2	2	LOWER UNIT COSTS					
4	4	3	3	2	4	3	2	AGRIBUSINESS SAVINGS					
2	2	2	2	2	2	2	2	LOWER U S FOREIGN ASSISTANCE					
2	2	2	2	2	2	2	2	BENEFITS IN LESSER DEVELOPED COUNTRIES					
PREDICTIONS	CROP IDENTIFICATION	CROP AREA LOCATION	STRESS IDENTIFICATION	STRESS SEVERITY	STRESS LOCATION	STAGE OF GROWTH	GROUND CONDITIONS	WEATHER	SENSORS				
									MEASUREMENTS	MULTISPECTRAL TELEVISION	MULTISPECTRAL SCANNER	MULTIBAND RADAR	MICROWAVE RADIOMETER
4	4	3	3	3	3	4	2	MINIMUM DAILY TEMPERATURE	4	1	4	2	1
4	4	3	3	3	3	3	2	MAXIMUM DAILY TEMPERATURE	4	1	4	2	1
4	4	2	2	2	2	2	2	RAINFALL	3	2	1/2	2	2
4	4	2	2	2	2	2	3	SOIL MOISTURE	3	2	2	2	2/3
2	2	2	2	2	3	4	4	PLANT TEMPERATURE	4	1	4	3/4	1
3	3	2	2	2	2	4	4	RESPIRATION	4	4	4	4	4
3	3	2	2	2	2	4	4	EVAPOTRANSPIRATION	4	2	4	3/4	2
1	1	3	3	3	2	4	4	ACRES OF WHEAT	2	1	2	3/4	2/3
4	4	3	2	3	2	4	4	DENSITY (% GROUND COVERED BY WHEAT)	2	2	2	3/4	2/3
4	4	2	2	2	4	3	2	WIND (DIRECTION AND VELOCITY)	4	4	4	3/4	4

Exhibit 22 Sequential Matrices Relating Sensors To Wheat Management

ration by independent measurements of earth phenomena are similarly required

The four satellite constellation proposed for water management would give nearly complete world wheat coverage every 3 days. Only Scandinavia and the most northern wheat regions of the Soviet Union would not be included in the observations. Even though much of the information could be obtained on an average of every 6 hours, it is unnecessary to provide for the higher transmission and computational costs of immediate processing. Supplying global harvest forecasts to the ultimate user about every 7 days is considered sufficient for timely decisionmaking.

The Willow Run Laboratory extrapolations of laboratory and aircraft multispectral scanner signatures to satellite altitude indicate a detection capability of over 90 percent and a false alarm rate of less than 0.1 percent for wheat and similar grains, using only three of a possible seven channels on any one pass. For wheat yield, required observations and projected accuracies are not unlike those for hydrology. A review of the potential cloud cover problem showed that sufficient samples for homogeneous areas could readily be obtained at all of the required

times of the year. Furthermore, cloud coverage is not a major problem because the climate in world wheat growing regions provides sufficiently cloudless conditions during critical periods of the growing season.

C WHEAT RUST CONTROL

1 Background

Over the last decade an average of 80.5 million bushels per year have been destroyed by wheat rust in the United States alone. Farmers, currently lacking adequate and timely information to diagnose and predict wheat rust epidemics, have undertaken only modest spraying operations. Although considerable effort has been devoted to the development of rust-resistant wheat, the wheat rust strains can mutate faster than commercial quantities of resistant wheat varieties can be planted.

The location and acreage of wheat grown in the United States is shown in Exhibit 23. Wheat rust spores spread north during the spring from Mexico and Texas in patterns that typically might look like the plumes shown in the exhibit. In the fall there is a movement of spores from north to south (not indicated on the exhibit).

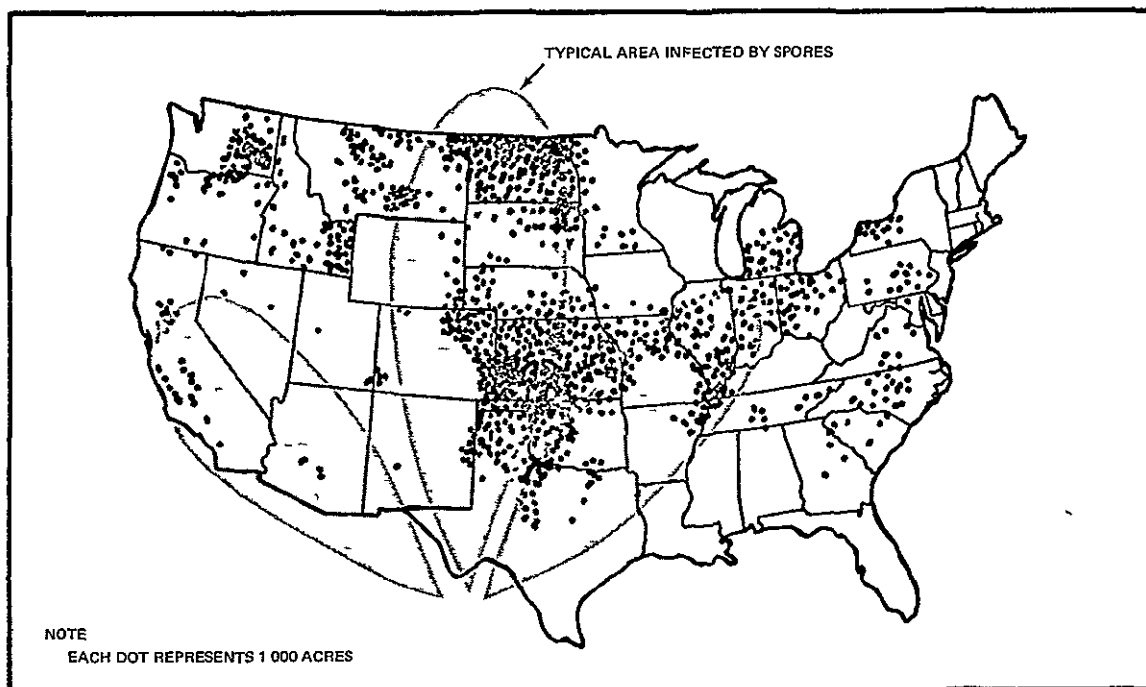

Exhibit 23 Wheat Acreage in the United States with Patterns of Possible Rust Infection

2 Wheat Rust Control Problem

It has been shown¹ that chemical control of rusts will produce substantial benefits if applied in a timely manner. Promising protectant fungicides, particularly in the Maneb group, are being developed and are suitable, according to authorities in the Food and Drug Administration, for grains destined for human consumption. Effective use of this type of rust control depends on timely and accurate predictions of impending rust epidemics so that farmers can spray under appropriate conditions.

While the ultimate user of information on identification and forecasting of wheat stress is the wheat grower, suppliers to the agricultural community are also concerned. Since benefits will stem from reduction in loss of wheat, the system must provide information directly usable by farmers so that their actions will produce realizable benefits.

3 User Models

The information needed to monitor and forecast rust epidemics requires a large number of observations. In the spring a rust spore cloud typically rises to an altitude of 5,000 to 10,000 feet over Mexico and Texas and is spread north by wind into wheat growing areas. Rainstorms carry the spores from the cloud to wheat fields underneath. To forecast an epidemic, it is necessary to predict or detect the developing spore clouds, the direction and speed of their movement, and the susceptibility of wheat varieties beneath a rainstorm to rust epidemic. In addition, since climatic conditions such as free moisture and sunshine will influence germination of spores and infection of wheat, these conditions must also be known for areas of potential rust damage.

¹G W Buchenau, and L W Carlson, "Chemical Control of Wheat Stem and Leaf Rust," *South Dakota Farm Home Res.* 1966, Vol 17, No 2, pp 4-7

Since the system suggested for control of wheat rust is based on continuously updated predictions, the value of satellite sensor data lies in the ability to monitor periodically wheat areas in Mexico and Texas. As rust patterns develop in these southern areas, antecedent conditions favorable to rust infection would be continuously monitored in the major northern wheat-growing areas. These data, combined with reasonable meteorological forecasting, should permit path prediction of spore clouds from the infected fields in the south. Farmers in susceptible areas in the path of rust spore clouds could be warned in sufficient time to spray under the most effective conditions.

4 System Integration

System integration involved the analysis of the relationships among all components (satellites, their orbits, remote sensors, ground stations, data processing, and means for disseminating information directly usable by farmers). It was accomplished in a manner similar to the analysis of water management and wheat yield management. System relevance matrices similar in form to those for the previous studies are shown in Exhibit 24. While there is a need for complementary ground systems in each of the cases studied, the need is even more evident in wheat rust control. Effective operation of the system, for example, is dependent upon ground truth sampling for verification of spore cloud tracking.

In developing an integrated simulation model, a scenario was developed to describe the process of the spread of rust infection from Mexico to Canada. The general parameters, their timing in the scenario, pattern confirmation, and related elements were all considered. By using simulation, by incorporating the known accuracies of sensors, and by utilizing the potential for repeated observations, the analysis indicated the system could be effective in preventing loss from rust and thus increasing wheat yield.

								MANAGEMENT DECISIONS AND BENEFITS	LEGEND					
	3	3	2	2	2	2	2	INCREASED YIELDS	1 SUFFICIENT 2 MAJOR CONTRIBUTION 3 CONTRIBUTION 4 SLIGHT CONTRIBUTION					
									SENSORS					
PREDICTIONS	CROP IDENTIFICATION	CROP AREA AND LOCATION	CROP VIGOR	STRESS IDENTIFICATION	STRESS SEVERITY	STRESS LOCATION	INFECTION PROBABILITIES		MEASUREMENTS	MULTISPECTRAL TELEVISION	MULTISPECTRAL SCANNER	MULTIBAND RADAR	MICROWAVE RADIOMETER	INFRARED SCANNER
	4	4	3	3	3	3	2		MINIMUM DAILY TEMPERATURE	4	1/2		4	1/2
	4	4	3	3	3	3	2		MAXIMUM DAILY TEMPERATURE	4	1/2		4	1/2
	4	4	2	4	4	2	2		RAINFALL	3	2	1/2	2/3	2/3
	4	4	3	3	2	2	2		SOIL MOISTURE	3	2	2	2/3	2/3
	2	2	2	2	2	2	4		PLANT TEMPERATURE	4	1/2	4	3/4	1/2
	3	3	3	2	2	2	2		RESPIRATION	4	4	4	4	4
	3	3	2	2	2	2	2		EVAPOTRANSPIRATION	4	2	4	3/4	2
	1	1	4	4	4	4	4		ACRES OF WHEAT	2	2	2/3	3/4	3
	4	4	4	4	3	2	2		WIND (DIRECTION AND VELOCITY)	4	4	3/4	3/4	4

Exhibit 24 Sequential Matrices Relating Sensors to Wheat Rust Control

IV BENEFIT-COST ANALYSIS

IV BENEFIT-COST ANALYSIS

A SYSTEM COSTS

As discussed in Section I, Introduction, benefits were calculated separately for each of the three cases studied. Costs, however, were calculated for the total system needed to support water management, wheat inventory/yield management, and wheat rust control. Since most elements of the system were used to various degrees in all three cases, no allocation of total costs was made to the different types of users of satellite-assisted information.

Total system costs were developed for the study period 1970-90 and summarized under three categories: research and development, investment, and operation. Exhibit 25 shows undiscounted annual costs estimated for each year of the study period by each category. According to the assumptions of the study, research and development costs will drop to a low value by 1975 to reflect selection of components that are or can be available in the near term. Continued research and development expenditures not

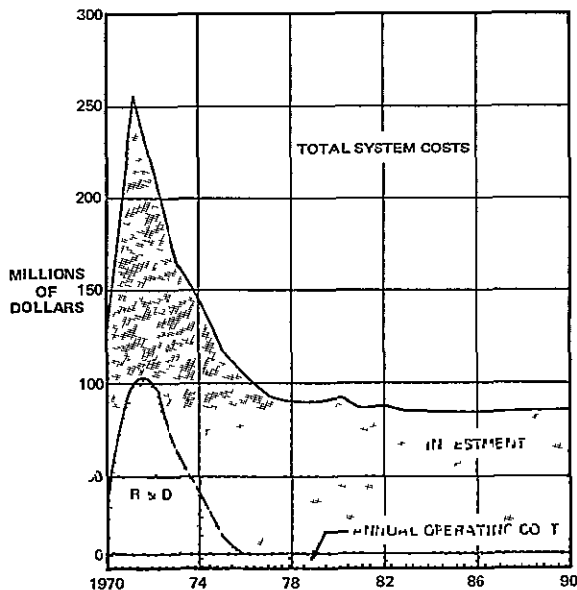

Exhibit 25 Annual Total System Costs 1970-90 in Billions of 1968 Dollars

shown in the exhibit would support more advanced systems. Similarly, investment costs peak in the early years to put the system in operation in 1973.

In order to provide for more meaningful comparisons with the benefit streams, the total cost stream was discounted to present value. Exhibit 26 shows the total costs discounted to present value at rates of 7½, 10, and 12½ percent. The effect, of course, is to reduce the present value of costs expected to be incurred in the later years of the study period. For example, to provide for a one million dollar investment not needed until 1990, it would be necessary to invest only 150,000 dollars in 1970 at 10 percent compounded annual rate.

B WATER MANAGEMENT BENEFITS

1 Benefits in the Pacific Northwest

The process of estimating water management benefits stemming from a satellite-assisted information system was the following. Using the Pacific Northwest, Columbia River Basin, benefits were estimated separately for each of four major purposes of water management: power generation, flood control, irrigation, and recreation. Next, Pacific Northwest benefits for each purpose were separately extrapolated to each major river basin in the United States. In each instance, the extrapolation accounted for differences in geography, development, and use between the Columbia River basin and the basin under study. Finally, a rough extrapolation was made of potential benefits to the rest of the world.

a Power Generation Benefits

Power generation benefits resulting from improved information and revised management rules were categorized as follows: (1) drawdown management of the reservoirs can be improved, (2) hedge (reserve) factors can be reduced, (3) interreservoir flows can be more optimally coordinated, and (4)

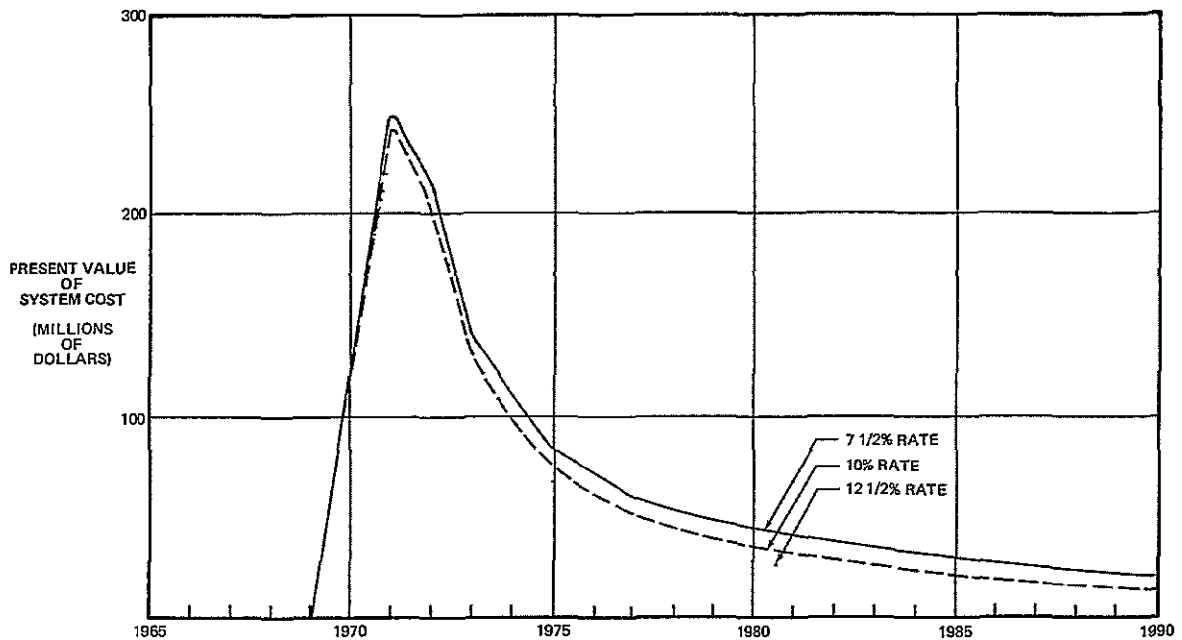

Exhibit 26 Annual Total System Costs 1970-90 Discounted to Present Value (1970 Dollars)

head efficiency (water pressure due to height of water above turbines) can probably be improved. In the last category, it was expected that head efficiency could be increased, but it was not possible to quantify benefits from this improvement in the current study. Benefits were calculated for two separate time frames, 1970-75 and 1976-90, based on the number of dams in operation during those periods. Power benefits for the first three categories are plotted in Exhibit 27 for the period 1970-90 using a discount rate of 10 percent. The sharp drop in drawdown benefits about 1979 accompanied by a sharp increase in hedge benefits results from an increase in the number of dams in operation. The decrease in total power benefits after 1977 reflects the effect of the 10 percent discount rate. For example, undiscounted benefits for the year 1985 would be 90 million dollars.

b Irrigation Benefits

Irrigation benefits are expected to result from improved farm management made possible by more accurate predictions of available moisture. Farmers have the opportunity of shifting crops and methods of farm operations to optimize production under various hydrologic conditions. Historic perspective shows that without adequate information the farmer's estimate of the moisture year expects will be

in error by about 20 percent. The kind of information made available from a satellite assisted system should allow irrigation farmers to reduce this error to as little as 5 percent. The resulting benefits estimated for the Pacific Northwest are shown in Exhibit 28.

c Flood Control Benefits

Flood control and alerts could also result in benefits from a satellite assisted information system, since the revised management rules applied to power management also reflect the requirements on the system posed by the flood control and irrigation interests. In fact, power generation tends to be a residual calculation after the other two more compelling interests have been served. It appears that

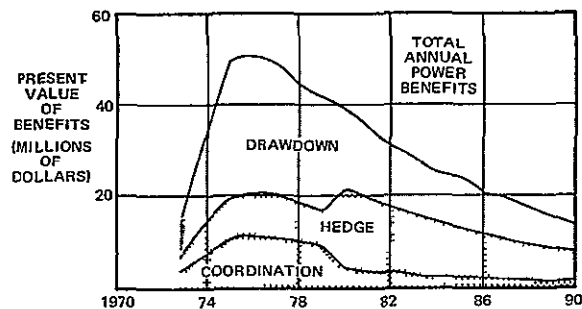

Exhibit 27 Annual Pacific Northwest Power Benefits 1973-90 Discounted to Present Value at 10 Percent (1970 Dollars)

where sufficient control dams exist, improved information can be used to reduce average flood stage levels by about 2 feet. This reduction would reduce current flood damages by about 75 percent. The projected annual direct savings in the Northwest are shown in Exhibit 28.

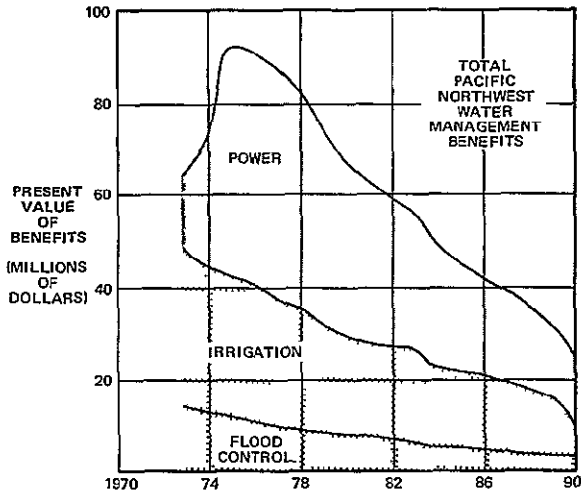

Exhibit 28 Annual Pacific Northwest Water Management Benefits 1973-90 Discounted to Present Value at 10 Percent (1970 Dollars)

d. Recreation Benefits

Recreation benefits will accrue if the levels of streams and reservoirs can be held higher and steadier to attract tourists during the summer period. The information made available through the satellite-assisted system would permit a more rapid fillup of reservoirs in the late spring and early summer and would allow a more judicious drawdown during the late summer months. The end result would be to create modest benefits due to increased tourism as shown in Exhibit 28.

Navigation benefits do not seem to be significant. Current management practices guarantee channel depth required for navigation. Improved information might increase channel depths, but with little or no advantage to the shipping community.

2 Extrapolation to the United States and the World

Benefits for other regions and countries can be estimated most accurately by examining these areas basin by basin. For example, in extending the water management analysis into upper California, control of water salinity becomes an important con-

sideration. In the Pacific Northwest, on the other hand, salinity has very little significance.

For this study, a rough extrapolation formula was developed to estimate, from analysis of the Pacific Northwest, the probable benefits to be anticipated in other regions (see Volume II, Technical Report). The method used for the United States includes such factors as current hydropower sales, importance of reservoirs versus run-of-river dams, rainfall patterns, and irrigated land areas. Using the estimated benefits for the United States as a guide, ratio techniques were then used to extrapolate benefits to the rest of the world. Estimated United States and world benefits of improved water management are shown in Exhibit 29.

3 Sensitivity Analysis

Since the satellite-assisted information system is complex, the level of benefits will be sensitive to many parameters. In general, increased research and development will be required to improve the reliability of sensor signatures. However, the current state-of-the-art in sensor technology does not require a major breakthrough either in sensor equipment or in resolution capabilities. Thus, research and development should be directed toward improving signature identification rather than sensor spatial resolution.

The integrated system does, however, depend heavily on earth science simulation models. Although the basic disciplines are developed, it is expected that increased benefits could be realized from research to develop subbasin runoff times, techniques of pattern recognition, and other components of the integrated system related to hydrology, meteorology, and earth-based sciences. It is important to note, however, that no single component of the integrated model is so deficient that the system will not operate without a major breakthrough.

Since benefits are also sensitive to the assumed discount rate, those from improved water management generally have been calculated using a 10 percent discount rate. Exhibit 30 shows the effects on the benefit stream using 7½, 10, and 12½ percent discount rates. The buildup in benefits to 1975 shows an increase in user participation as the system becomes operational. The decrease in benefits after 1975 reflects the effect of the discount rates.

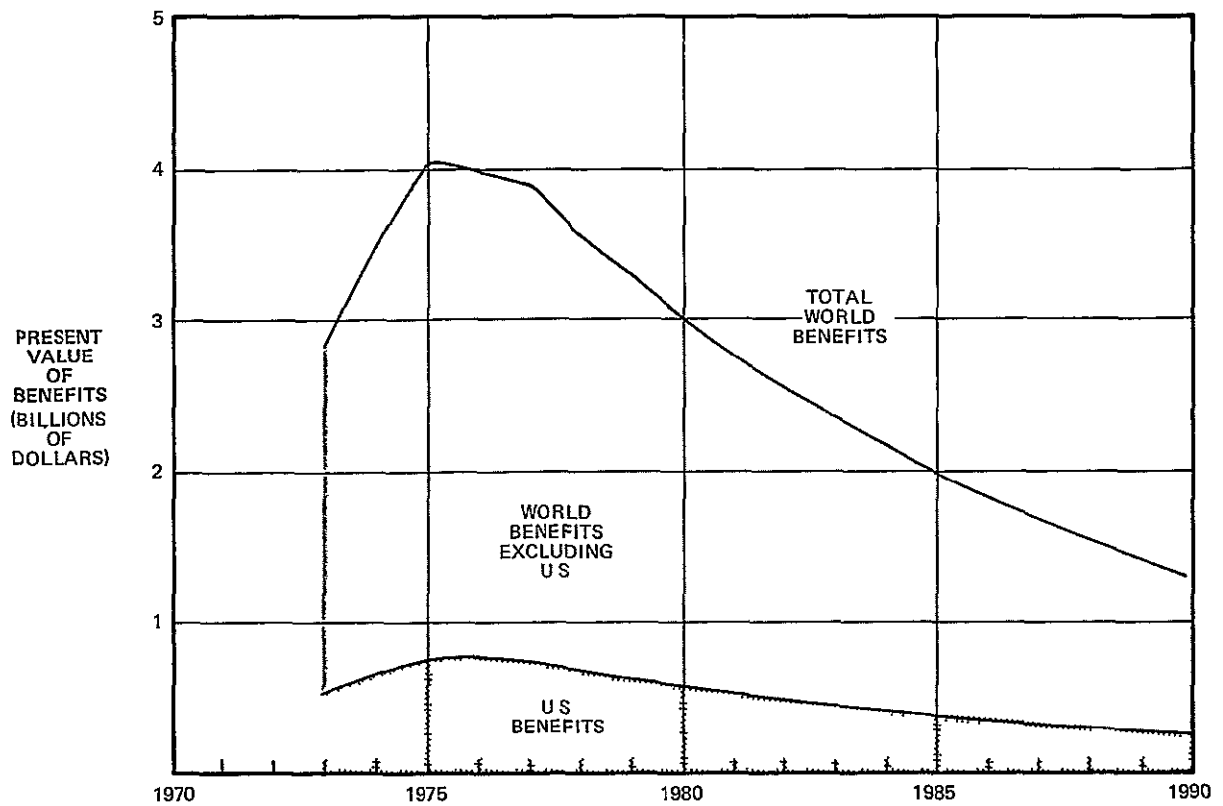

Exhibit 29 Annual U S and World Water Management Benefits 1973 90 Discounted to Present Value at 10 Percent (1970 Dollars)

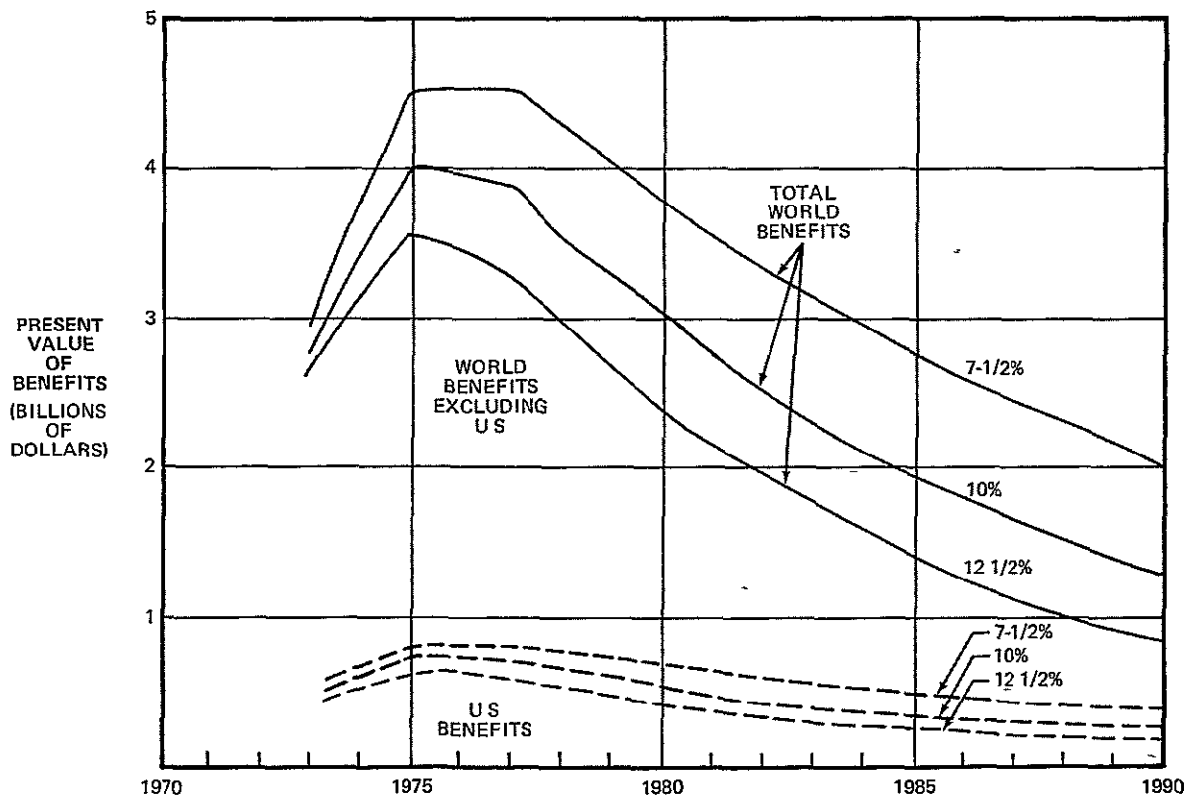

Exhibit 30 U S and World Annual Water Management Benefits 1973 90 Discounted to Present Value at 7½, 10 and 12½ Percent (1970 Dollars)

C WHEAT CROP MANAGEMENT BENEFITS

The use of information that could be provided by a satellite assisted system will tend to stabilize world wheat production. Benefits in the United States will accrue to the government, to domestic producers, and to suppliers of goods and services to the agricultural sector. It is inherent to the wheat crop management system that benefits could also be provided to other countries in the world. That is, knowledge of expected wheat yield in one region of the world directly affects wheat crop management in other distant regions of the world. This is in contrast to water management and wheat rust control, where each region can use the information to produce benefits relatively independently from other regions.

In studying wheat inventory and wheat yield for the United States, the expected benefits from a satellite-assisted information system were grouped under five categories. There were benefits from

- Reduced CCC stocks
- Improved selection of options by producers
- Reduced unit production costs
- Improved return on U.S. foreign aid
- Savings to suppliers to the agricultural sector

Exhibit 31 shows total benefits to the United States broken down by these categories and discounted to present value at 10 percent.

The CCC benefits would stem from reduction in stock holdings made possible by the information system. Benefits to farmers stem from reduced unit costs per bushel, which are expected to follow from improved preplanting planning made possible by improved knowledge of world conditions. Farmers would also derive benefits from shifts in production made possible through improved knowledge of world wheat conditions, domestic winter wheat conditions, and improved weather information. Businesses that provide farm machinery, fertilizer, chemical pesticides, and services could derive modest benefits principally from reduced storage costs and improved business planning.

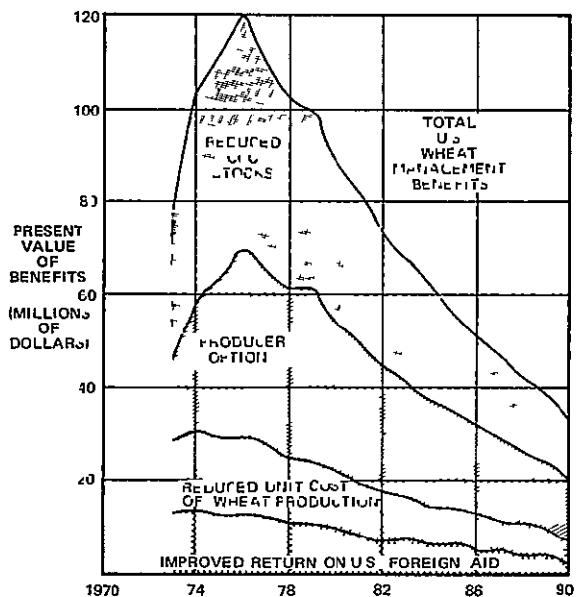

Exhibit 31 Annual U.S. Wheat Management Benefits 1973-90 Discounted to Present Value at 10 Percent (1970 Dollars)

In developed countries, world benefits stem from reduced unit costs and from producer options that could be made available to wheat producers. In the lesser developed countries, benefits are made possible by shifts in national agricultural plans. In many of these countries, where nearly continuous cropping is practiced, continual monitoring of the crops would permit periodic adjustments during a year. As a result of such decisions, the improved growth rates possible for these lesser developed countries would in turn be reflected as increased return on U.S. economic assistance investment in such countries. Three categories of world benefits estimated for improved wheat crop management (not including U.S. benefits) are shown in Exhibit 32. Reduced unit wheat production costs and better selection of producer options are more significant in developed countries, while an improved gross national product is more significant in lesser developed countries.

D WHEAT RUST CONTROL BENEFITS

The benefits attributable to a satellite assisted information system used for wheat rust control are measured in terms of reduction in loss of crops. Although wheat rust was the central focus of the study,

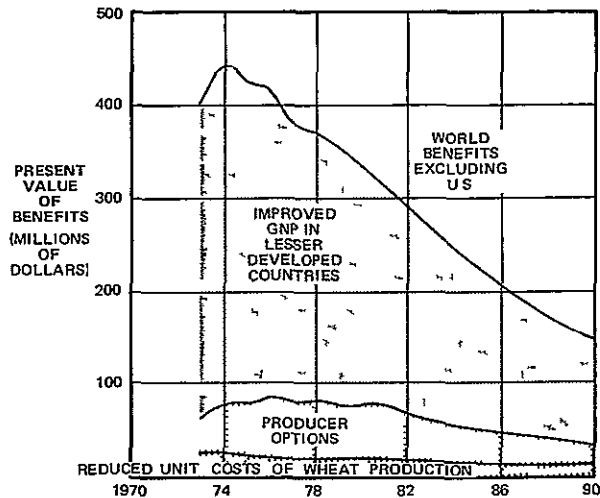

Exhibit 32 Annual World Wheat Management Benefits Excluding US 1970 90 Discounted to Present Value at 10 Percent (1970 Dollars)

the system could provide benefits to other crops subject to similar fungi. The benefits estimated to accrue to the United States for the period 1973-90 are shown in Exhibit 33. Total US benefits discounted to present value at a rate of 10 percent are divided into three categories: wheat rust, other wheat fungi, and fungi that attack other small grains. Estimated possible benefits to the rest of the world are shown in Exhibit 34.

The benefits estimated in the two exhibits are based on the assumption that a satellite assisted information system will foster chemical spraying that will be 95 percent effective during the 1973-79 period and 100 percent effective during the 1980-90 period. Participation by farmers was assumed high for two reasons. First, the trend over the past 4 years has been toward greater farmer participation in programs designed to eliminate or eradicate plant pests and diseases. Second, and more important, has been the trend toward larger farm enterprises with consequent capability and motivation for efficient production. The larger and more capable operator tends to adopt farming procedures for which benefits in terms of investment returns can be clearly demonstrated. Although participation by foreign agricultural producers cannot be predicted with certainty, participation percentages were assumed to estimate potential world benefits.

The estimated benefits shown in Exhibits 33 and 34 are dependent on assumptions concerning the effectiveness of chemical spraying at appropriate times. While lack of appropriate farmer participation can re-

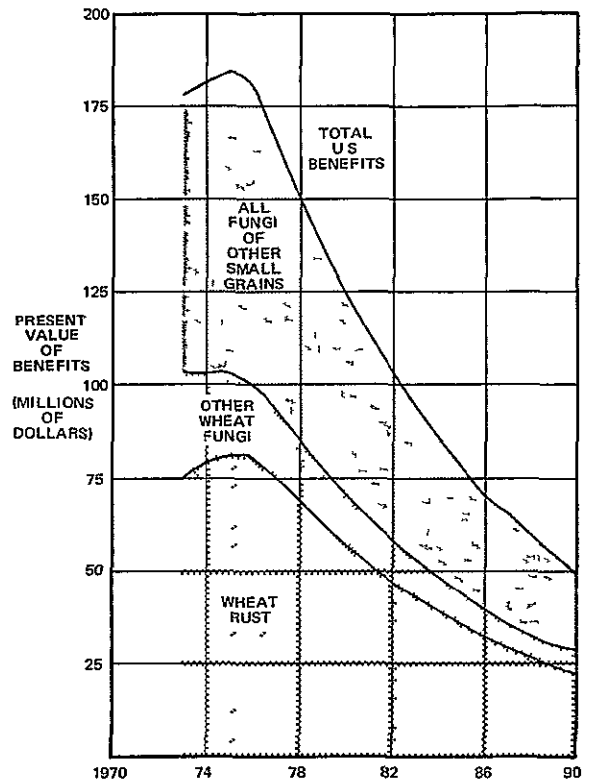

Exhibit 33 Annual US Fungi Control Benefits 1973 90 Discounted to Present Value at 10 Percent (1970 Dollars)

duce benefits, it should be noted that spraying tends to start a cumulative downward spiral in fungi epidemics. Hence, total system effectiveness will become less sensitive to the assumption of 100 percent participation.

The space segment, ground stations, and processing center cost for water management was sufficient for wheat crop management. The same system would also be appropriate in terms of sensors, coverage, and frequency of observation to satisfy rust con-

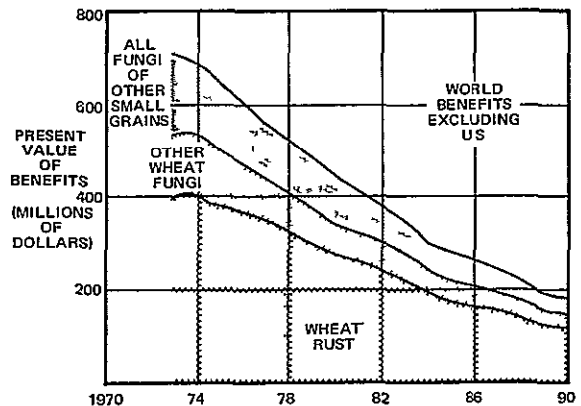

Exhibit 34 Annual World Fungi Control Benefits Excluding US 1973 90 Discounted to Present Value at 10 Percent (1970 Dollars)

trol The increased cost of spraying must be included in the latter case These costs were estimated to be less than \$20 million per year

E BENEFIT-COST ANALYSIS

In the preceding subsections both costs and benefits have been discounted to present value at a 10-percent rate This procedure permits comparisons of the 20 year (1970-90) cost and benefit streams in terms of present value in 1970 dollars Exhibit 35 presents the comparison of discounted incremental cost stream for the entire satellite-assisted information system to expected benefits from water management in the US and to expected world benefits The comparison shows that the benefits expected from water management in the US alone are substantially greater than expected costs for the satellite-assisted information system capable of supporting water management, wheat crop management, and wheat rust control As indicated in the exhibit, costs are highest in the 1970-73 period while benefits do not begin until 1973 The drop in the value of both costs and benefits in the later years results from the use of the 10 percent discount rate

The benefit-cost ratio of 1.3 for Pacific Northwest water management application indicates that this region alone could support the total cost of the satellite-assisted system For substantially the same costs, the system could be used to manage water resources in the other major basins of the United States and raise the benefit cost ratio to 4.7 Assuming the rest of the world could use the same type of information for managing water resources, a rough extrapolation of United States data suggests that the benefit-cost ratio would increase to 25

The total costs and benefits for the satellite-assisted information system for the three cases studied are summarized in the table of Exhibit 36 The costs are broken into three major categories research and development, investment, and annual operating costs The total for the 1970-90 period is \$1.34 billion when discounted at 10 percent About one half are annual operating costs, and one fourth each are investment and research and development costs No basic research is required, but further development is required for several components For example, it will be necessary to verify that, at satellite altitude, the multispectral scanner, the multispectral

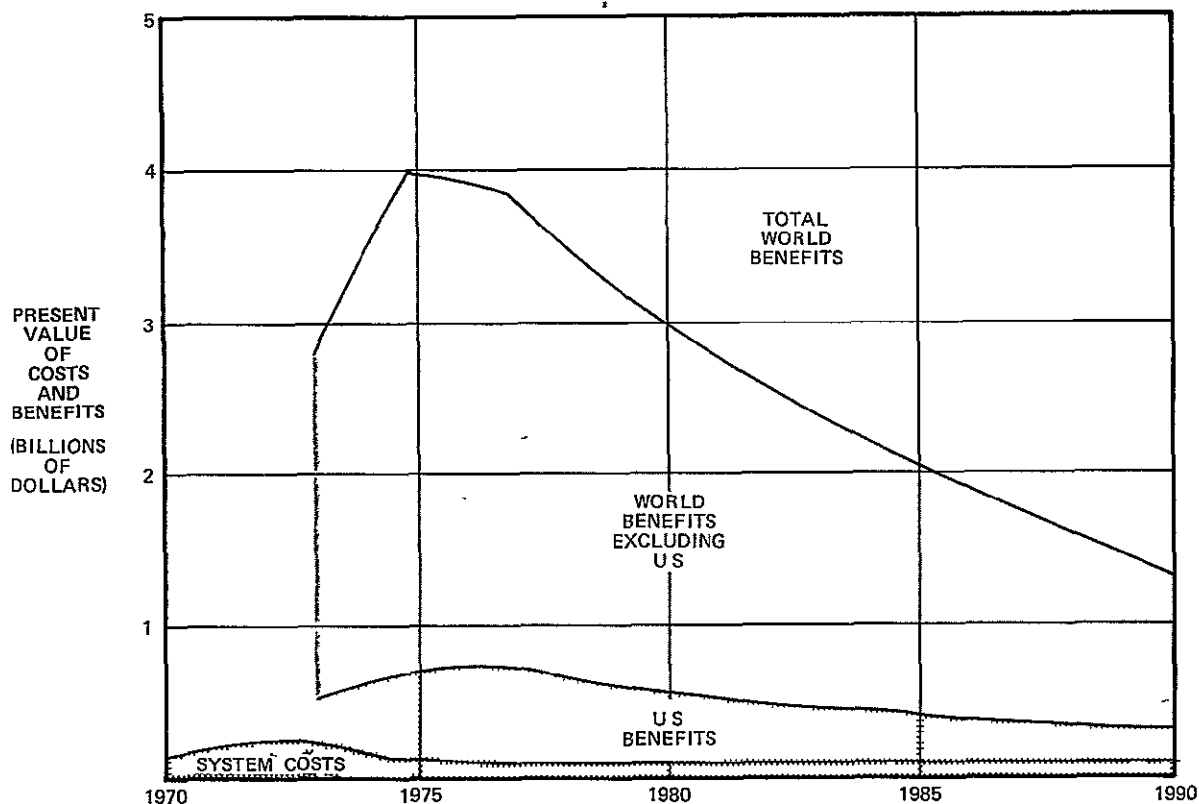

Exhibit 35 Annual US and World Water Management Costs and Benefits 1970-90 Discounted to Present Value at 10 Percent (1970 Dollars)

television, and the multiband radar will give expected identification and resolution accuracies. It will also be

*Exhibit 36 Satellite Assisted Information System
Total Costs and Benefits 1970-90 Discounted at 10 Percent*

Costs	United States	World
Research and development		
Earth sciences	\$0 07	
Sensor	0 14	
Sensor data acquisition and transmission	0 05	
Processing, rectification and orientation	0 02	
Automatic data interpretation	0 05	(not estimated in this study)
Historical data bank	0 00 ⁽¹⁾	
Decision analysis	0 01	
Subtotal	\$0 34	
Investment	0 36	
Annual operation	0 64	
Total	\$1 34	
Benefits		
Water management	6 3	\$34
Control of fungi diseases of small grains	1 0	5
Wheat inventory/yield	1 5	6
Total	\$8 8	\$45

Note: (1) Less than \$5 million

necessary to develop appropriate earth science sub-models to support the integrated system. The ground components for data acquisition, transmission, and automatic interpretation procedures use known techniques but require analysis and development.

If an operational system following the concept developed in this study were used to manage the three cases studied, the 1973-90 benefits to the United States discounted at 10 percent would be about \$8.8 billion. These benefits exceed costs for the satellite-assisted system by nearly seven times. If world benefits could also be realized, they would bring the total to about \$45 billion.

Exhibit 36 shows that the benefits from any one of the three cases on a global basis (and almost on a U.S. basis) would pay for the satellite-assisted information system. The four-satellite constellation capable of providing 6-hour coverage for Pacific Northwest water management is more than adequate for the other two potential applications studied and, in addition, might satisfy other missions not discussed in this report. Such further application could further enhance the benefit-cost comparison.

V ALTERNATIVES

0

V ALTERNATIVES

A. NONINFORMATION ALTERNATIVES

1 Water Management

Both the satellite- and aircraft supported remote sensor configurations are information systems designed to improve the decisionmaking process related to water management in river basins. There are alternatives to better information for improving water management. For example, power managers have the option of investing their resources to build new dams or nuclear power generating plants. In the Northwest, investment in a satellite assisted information system would bring a higher rate of return than investment in such alternatives. Benefit cost ratios estimated in this study for the Pacific Northwest (with benefit and cost streams discounted at 10 percent) are as follows:

- Satellite assisted information system 1.3
- New dam construction 0.9
- Nuclear power generating plants 0.06

As indicated in the previous section, the same satellite assisted information system is expected to show a benefit cost ratio of 4.7 when applied to the US and approximately 25.0 when applied to the world. The Bonneville Power Administration estimates that nuclear power expected to be available in 1980 will cost twice as much as Pacific Northwest hydropower, although the accuracy of this statement was not verified in this study. In addition, few, if any, new dam sites remain in the Northwest and, although power plants are an alternative, their cost is perhaps twice that for hydropower plants. Thus, the more effective alternative seems to be to expand low cost waterpower capacity through improved management control of existing or planned hydropower plants with the information provided by the satellite-assisted system.

2 Wheat Crop Management

A continuation of the current USDA policy and practices for determining annual wheat acreage allotments and carry-over CCC stocks appears to be the only noninformation alternative to providing better and more timely information on worldwide wheat management by a satellite-assisted information system. The current policy can and has resulted in considerable wheat carryover inventories (i.e., from 400 to 700 million bushels) and recurring overproduction.

Historical experience from 1953 to 1968 shows that stored inventories of US wheat have a range of about 100 to 1,300 million bushels. It is quite unlikely, however, that the present program would allow inventories to reach the high extreme of that range in the future. The present program has been modified recently to provide more flexibility to downward adjustments in average allotments. For purposes of this analysis, an average stored inventory of 400 million bushels, exclusive of pipeline supplies, was assumed for the 1970-90 period. This amount is less than the actual inventories experienced in most of the last 15 years.

The total annual cost of the current wheat storage program can be summarized in two major categories: annual operating costs and opportunity costs. During FY 1968, the average cost for storing and handling a bushel of wheat in the government reserves was 12.6 cents. The average per-bushel cost for transportation was 8.8 cents, and the average investment cost was \$1.52. Thus, assuming constant FY 1968 rates, the annual operating cost of a 400 million bushel storage program is \$0.126 + \$0.088 x 400 million, or \$85.6 million. If opportunity costs are assumed equivalent to 7.5 percent of total investment, then another cost of \$45.6 million (\$1.52 x 400 million x 0.075) must be added. The sum of the two major elements results in a total annual cost of \$131.2 million in constant FY 1968 dollars or a total of \$2.4 billion (undiscounted) over the 1973-90 period.

If the required storage program was closer to 700 million bushels (still less than actual inventories experienced in 11 of the last 15 years), the total undiscounted cost over the 1973-90 period would be \$4.1 billion.

3 Wheat Rust Control

Current efforts for controlling wheat rust are centered on developing varieties of wheat which are resistant to the predominant identified races of rust. Generally, there is a time lag of 8 to 15 years between the initial identification of a new race of potentially dangerous wheat rust and the subsequent availability in commercial quantities of a new wheat variety that is resistant to that race. Thus, early identification of new potentially dangerous wheat rust races is important if new varieties of wheat are to be made commercially available before any individual strain of rust can become widespread.

Currently, the Wheat Investigation Laboratory of the U.S. Department of Agriculture conducts a continuous survey of wheat rust, although the number of races identified annually in the United States rarely exceeds 10 percent of the total number of known races. Even though identification of a wheat rust race is not a critical parameter in chemical control, race identification procedures should remain an integral part of the rust management system to avoid the spraying cost when a particular race of rust is expected in a region where the variety of wheat being grown is known to be resistant to that race.

The program for breeding new varieties of rust-resistant wheat is a joint venture of the Wheat Research Laboratories, various state agricultural research stations, and commercial seed companies. The cost of this research, borne approximately equally by each of these three groups, is estimated to be about \$5 million per year (in 1968 dollars) for the United States alone. Of the total worldwide wheat research, an estimated 25 percent is currently performed in the United States. However, a large portion of other free-world research costs are paid by the United States. Much of the wheat research in Latin American countries, for example, is supported by grants from the Rockefeller and Ford Foundations. The USDA also supports research in many foreign countries, and many varieties of wheat developed in the United States are important to the economics of several foreign countries.

The study concluded that a breeding program appears to be only a partially effective solution to the wheat rust problem. Although the costs of implementing an augmented breeding program may be modest, the time lag in evaluating its effectiveness is excessive. Even though a satellite-assisted information system once in operation would provide timely and continuous assistance to resolving agricultural stress problems, the breeding program should be continued. It would appear prudent to have both programs complementing each other until more definite information on relative values of potential success or failure can be obtained.

B INFORMATION ALTERNATIVES

In all three cases studied, the satellite-assisted information system was compared to a system using remote sensors on aircraft.

1 Water Management

The data made available by a satellite-assisted system could at least in theory be provided by other means, such as aircraft. An appropriate aircraft system with equivalent capabilities was costed and compared with the satellite system (see Exhibit 37). For application to water management, the satellite-assisted system appears to be superior when a region of more than one million square miles must be monitored. The cost of the aircraft system (including data transmission costs) increases at a constant rate as additional relevant river basins in the United States are added. The cost then increases at a somewhat higher rate for coverage of the rest of the world (this is indicated by the increased slope in the curve at 1.6 million square miles in Exhibit 37). The satellite-assisted system undiscounted costs start at \$2.3 billion and then increase slightly because of additional data transmission costs. The aircraft system provides the same data as the satellite system (the same sensor package was used in both systems). Processing costs, when using the dynamic sampling technique, are about equal for each alternative.

2 Wheat Crop Management and Wheat Rust Control

As discussed in the introduction, the satellite-assisted information system concept proposed and costed in this study could support water management, wheat crop management, and wheat

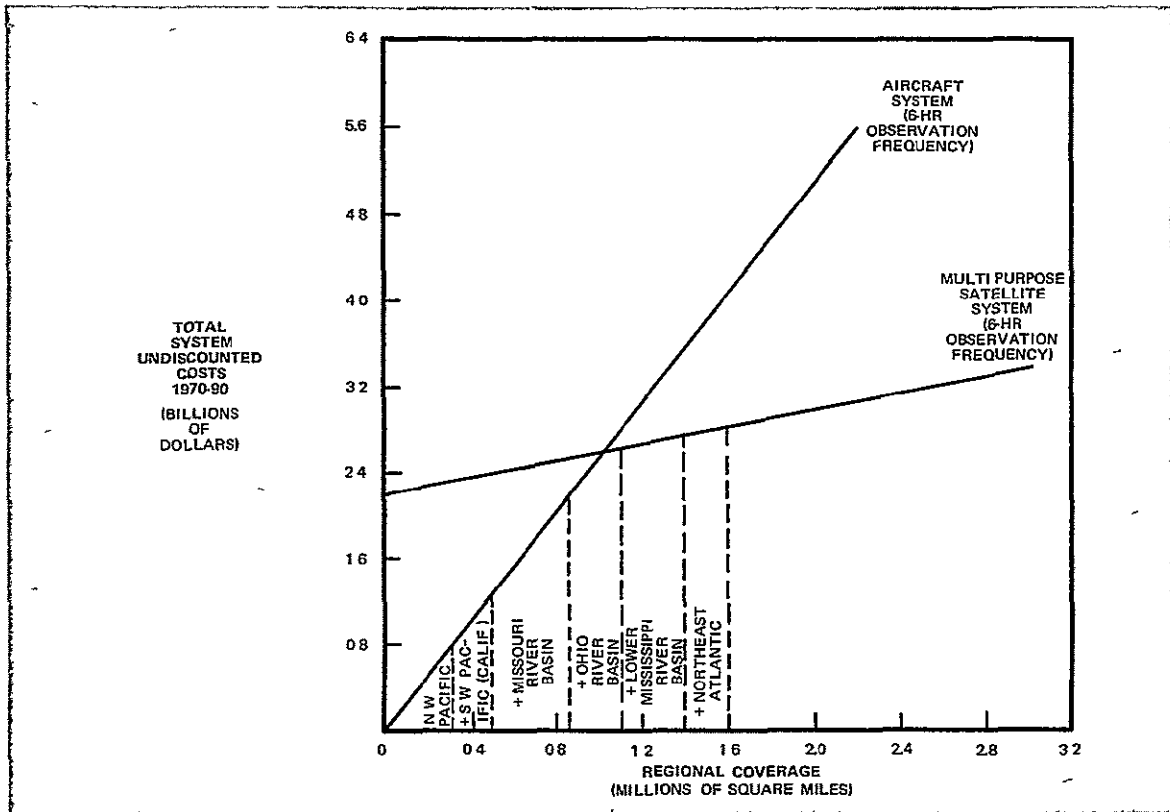

Exhibit 37 Costs of Multi Purpose Satellite and Aircraft Information Systems for Water Management

rust control No costs were allocated to the water and agricultural sectors served The analysis showed that the information requirements for water management exceeded those for agriculture, and that a satellite-assisted system for water management would be more than adequate for the agricultural problems If three different and independent satellite-assisted information systems were used, the system for water management would cost the most (i.e., the previously stated \$1.3 billion in present value), the other systems requiring less frequent observations and a smaller sensor package would cost less In fact, there is only one satellite assisted system to support all three sets of users Consequently the benefit-cost ratios, in effect, assume each set of users is paying for the system, and in addition the benefit cost ratios for the agricultural applications are lower than would be the case if they were supported by a less expensive but adequate system

The four-satellite system proposed for water management could be used simultaneously to manage wheat production, but if a satellite system were deployed solely for wheat production management the benefits could be obtained by using fewer

satellites and without radar The benefit of the system to the United States would largely accrue from our ability to monitor the total world small grain situation to permit optimal United States adjustments Management of wheat yield production was estimated to require observations only every 7 days Since the regions of the entire world having wheat fields is less than 1 million square miles, it is clear (see Exhibit 38) that an aircraft system would be less expensive than a multi-purpose satellite assisted system used solely for wheat

Wheat rust control requires observations every 12 hours over large portions of the United States as well as portions of northern Mexico and southern Canada The regions to be surveyed, the period of the survey, and the complexity of the sensor package all affect the costs Used solely for rust control, an aircraft assisted system would cost less than a multi-purpose satellite-assisted system

The curves shown in Exhibit 38 should not be compared directly as presented, since the aircraft-assisted information system curves are single purpose as indicated and hence designed for the performance

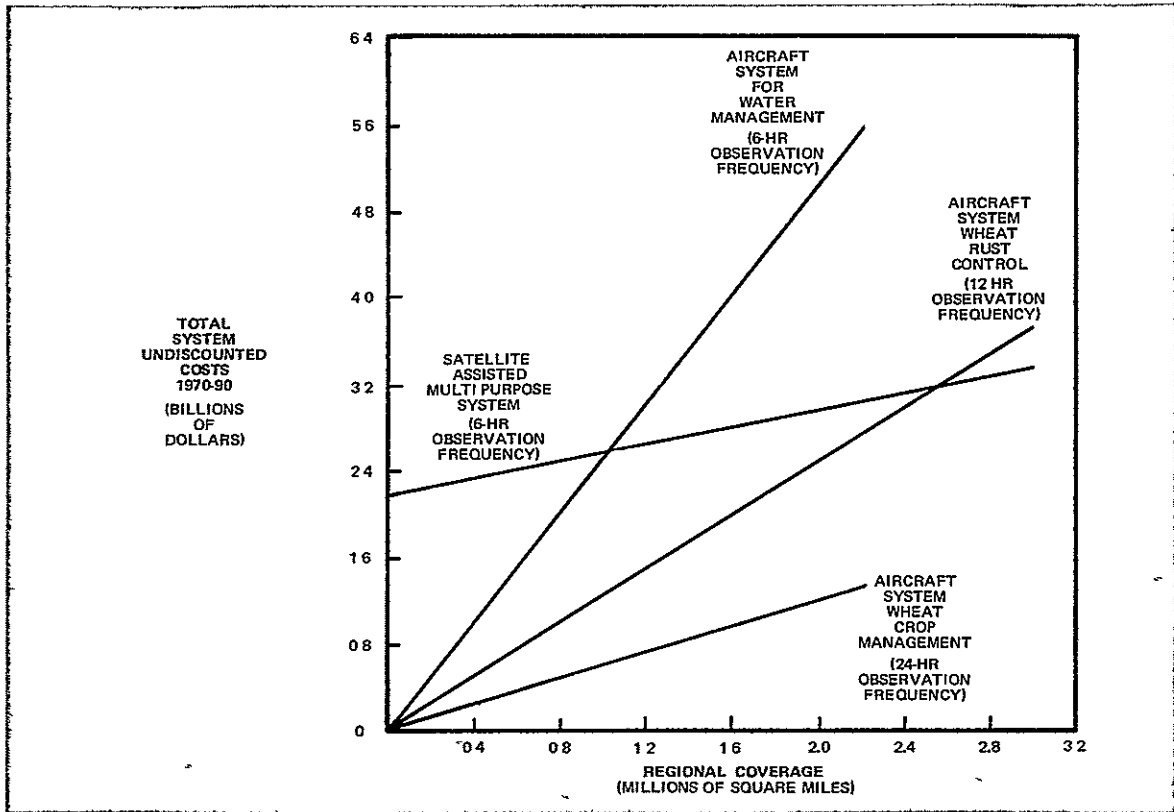

Exhibit 38 Costs of Satellite and Aircraft Information Systems

required. The satellite assisted information system costs are those of a multi-purpose system serving all three sets of users. Thus, if improved water management is a priority objective, this study indicated a multi purpose satellite-assisted information system with a single constellation of satellites to be most efficient. Such a system configured to satisfy the water management case requires observations every 6 hours, and a sensor package consisting of a multi-spectral scanner, a multispectral television, and multi-band radar. This system also would generate all the

information required for the two agricultural cases. The telemetering, processing, and dissemination to users can be readily performed within the times required for user decisionmaking. Thus, the satellite assisted system, which could be justified for water management if used for only a portion of the United States, could generate as byproducts the benefits projected in the agricultural cases here and abroad. In all likelihood, the same system could be extended to other problem areas not studied in this report where there is a need for timely, synoptic data.

VI CONCLUSIONS

VI CONCLUSIONS

The following are the principal conclusions to be drawn from the study

- A satellite assisted information system for water management, wheat crop management and wheat rust control, employing remote sensors in unmanned spacecraft is technically feasible and could, if research and development is adequately supported, be operational by the mid or late 1970's. The system concept presented in this study is intended to operate in conjunction with complementary ground systems.

- The system conceptualized in this study is multi purpose and could provide substantial benefits to different groups of users. Although alternative systems may be less expensive for some specific applications, the total costs for a multi purpose satellite assisted system are expected to be considerably less than the sum of benefits to the various user groups. In this study the anticipated water management benefits in the Pacific Northwest alone would be sufficient to pay for the entire satellite assisted information system. Benefits from other applications studied would then be obtained essentially without significant additional costs.

- The benefit cost ratios are sufficiently promising to suggest the need for intensification of the research efforts leading toward a possible future operational satellite assisted information system. Since the first series of dedicated Earth resources research satellites, designated Earth Resources Technology Satellites (ERTS), are scheduled to fly beginning in 1972, the timing of future decisions on the development of possible future operational systems should be closely coordinated with the ERTS as that program evolves. In addition to the space segment, of equal importance in timing is the extensive Earth based science and associated research and development that would be required to create an operational system such as that conceptualized in this study.

- A significant finding of the study is the requirement for intensified research and development in the Earth based science models, in user decision models, in data storage, retrieval, and processing, as well as in remote sensors. In particular, the development needed includes interpretive and predictive models which are based on physical phenomena appropriate to a selected earth activity and are structured to make effective use of the emerging capabilities of multispectral remote sensing.